

5/14/99

REVISIONS

PROJECT REFERENCE NO. U-5725/R-3822	SHEET NO. UC-3D
RW SHEET NO. UTILITY DESIGN ENGINEER	
8/9/2018 2:37:22 PM EDT	
DOCUMENT NOT CONSIDERED FINAL UNLESS ALL SIGNATURES COMPLETED	

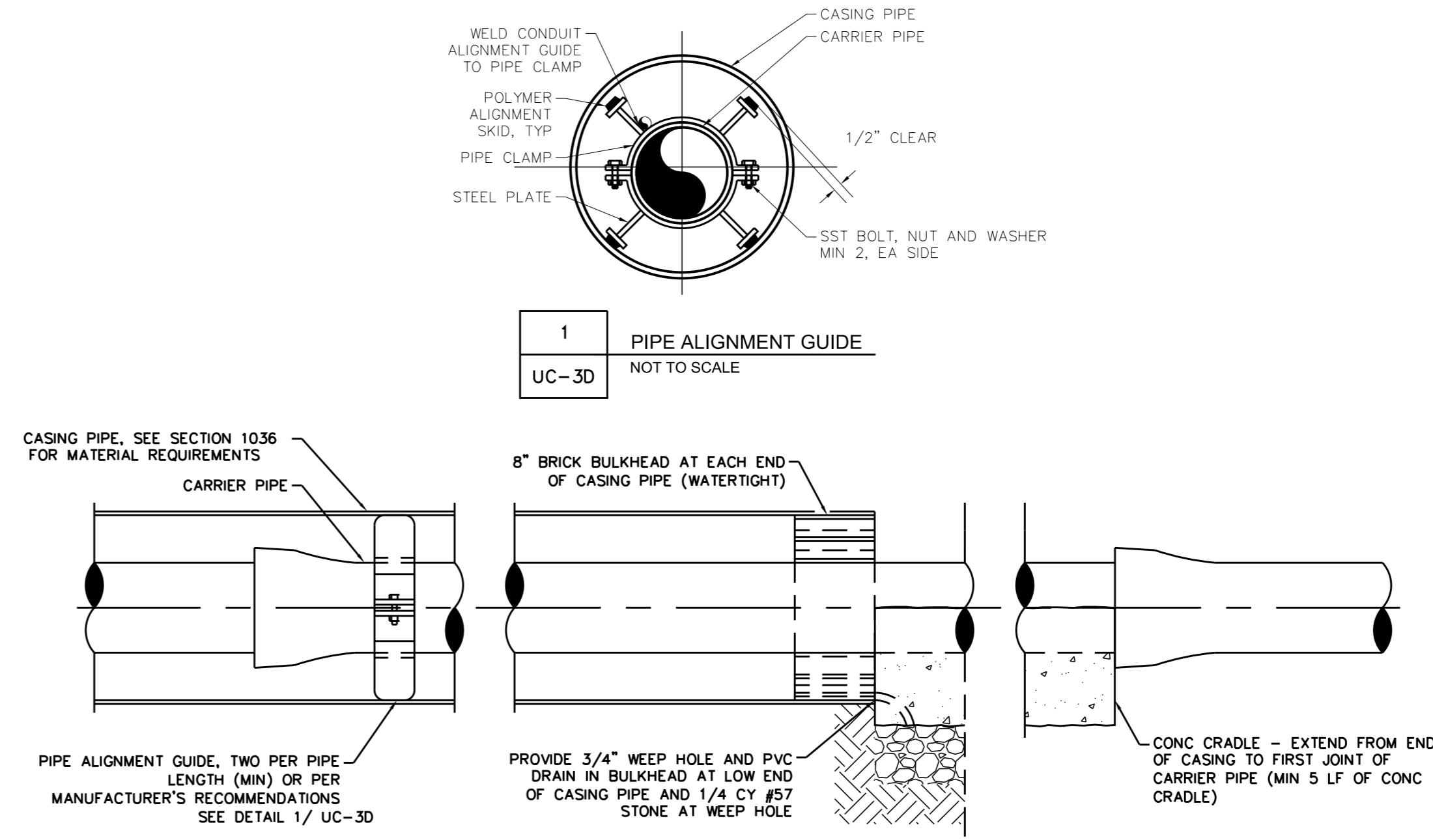
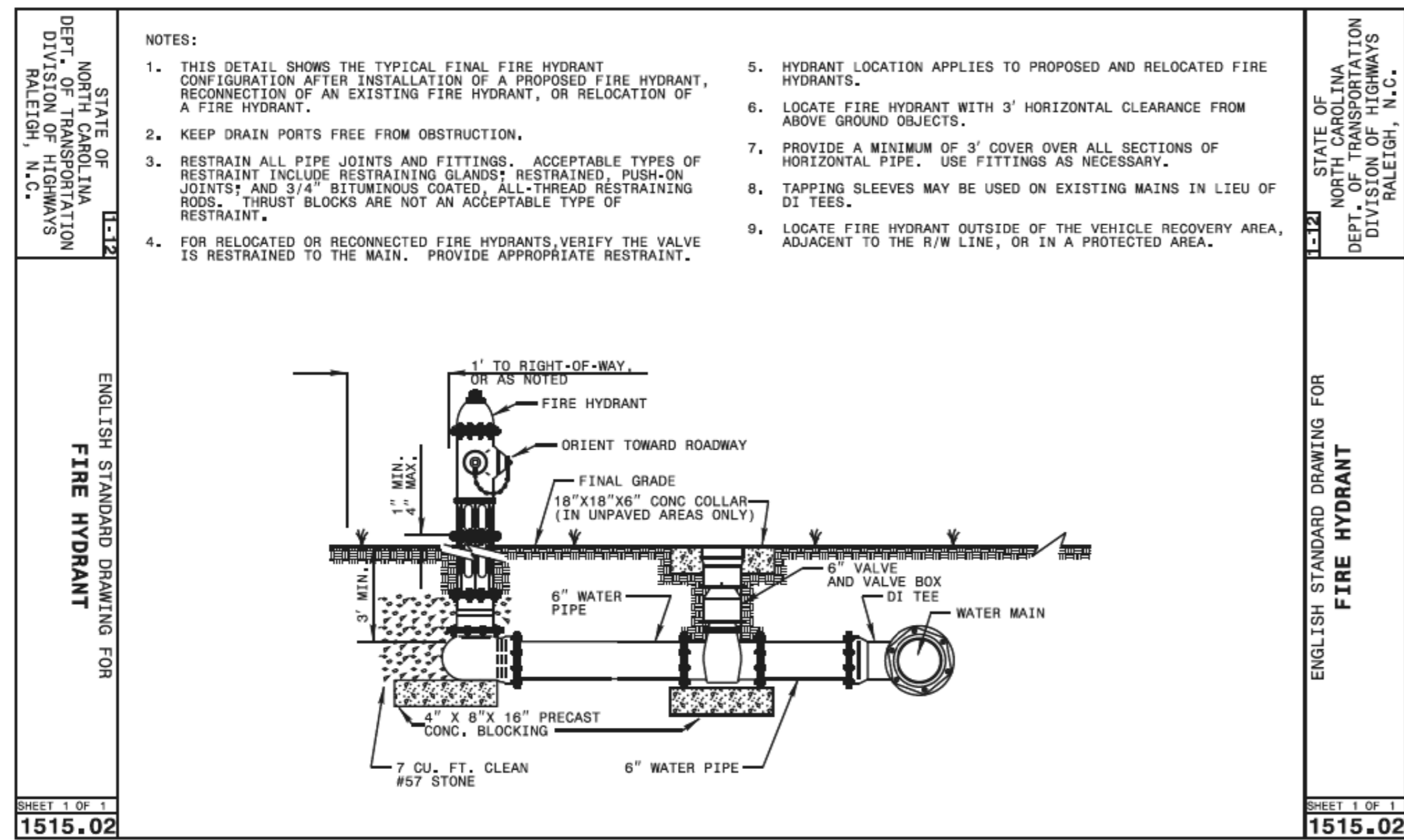
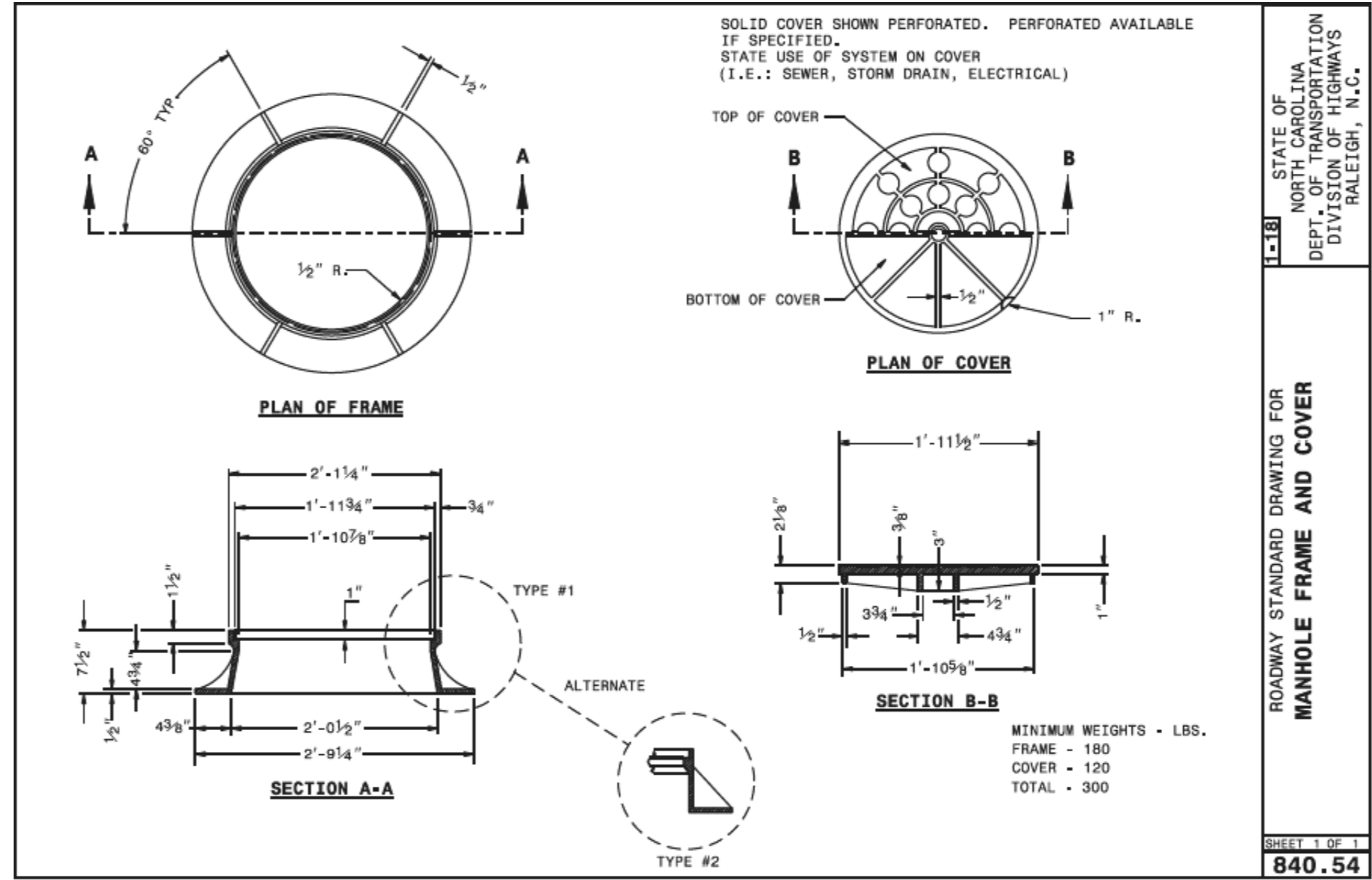
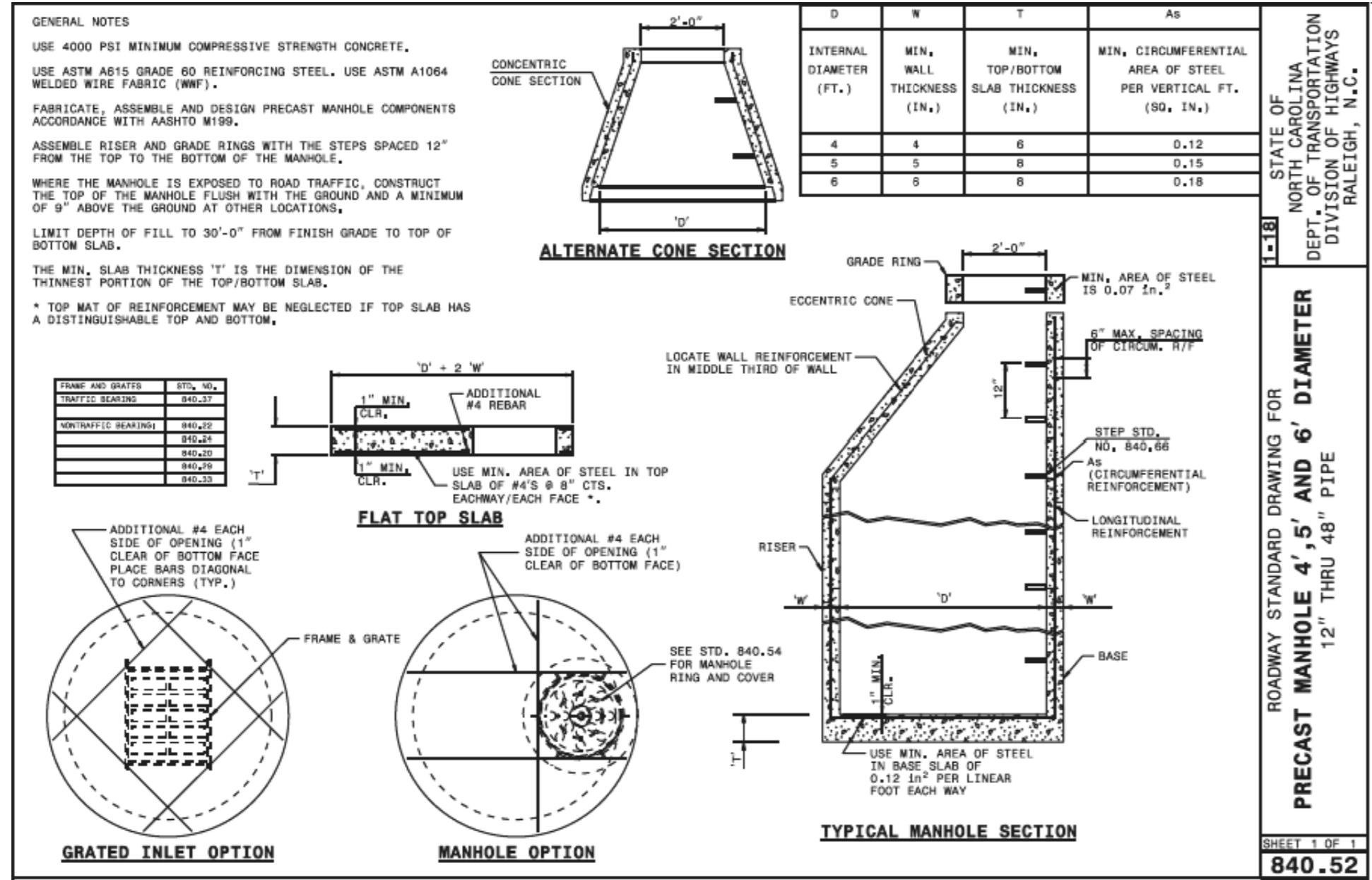

- NOTES:
 1. CASING PIPE FOR 8" CARRIER PIPE SHALL BE 16" (MIN) OUTSIDE DIAMETER WITH A MINIMUM WALL THICKNESS OF 0.250"
 2. CASING PIPE FOR 12" CARRIER PIPE SHALL BE 24" (MIN) OUTSIDE DIAMETER WITH A MINIMUM WALL THICKNESS OF 0.250"
 3. CASING PIPE FOR 16" CARRIER PIPE SHALL BE 30" (MIN) OUTSIDE DIAMETER WITH A MINIMUM WALL THICKNESS OF 0.312"

8/9/2018