

EDI MODEL 2018ECL-NC CONFLICT MONITOR
PROGRAMMING DETAIL

(remove jumpers and set switches as shown)

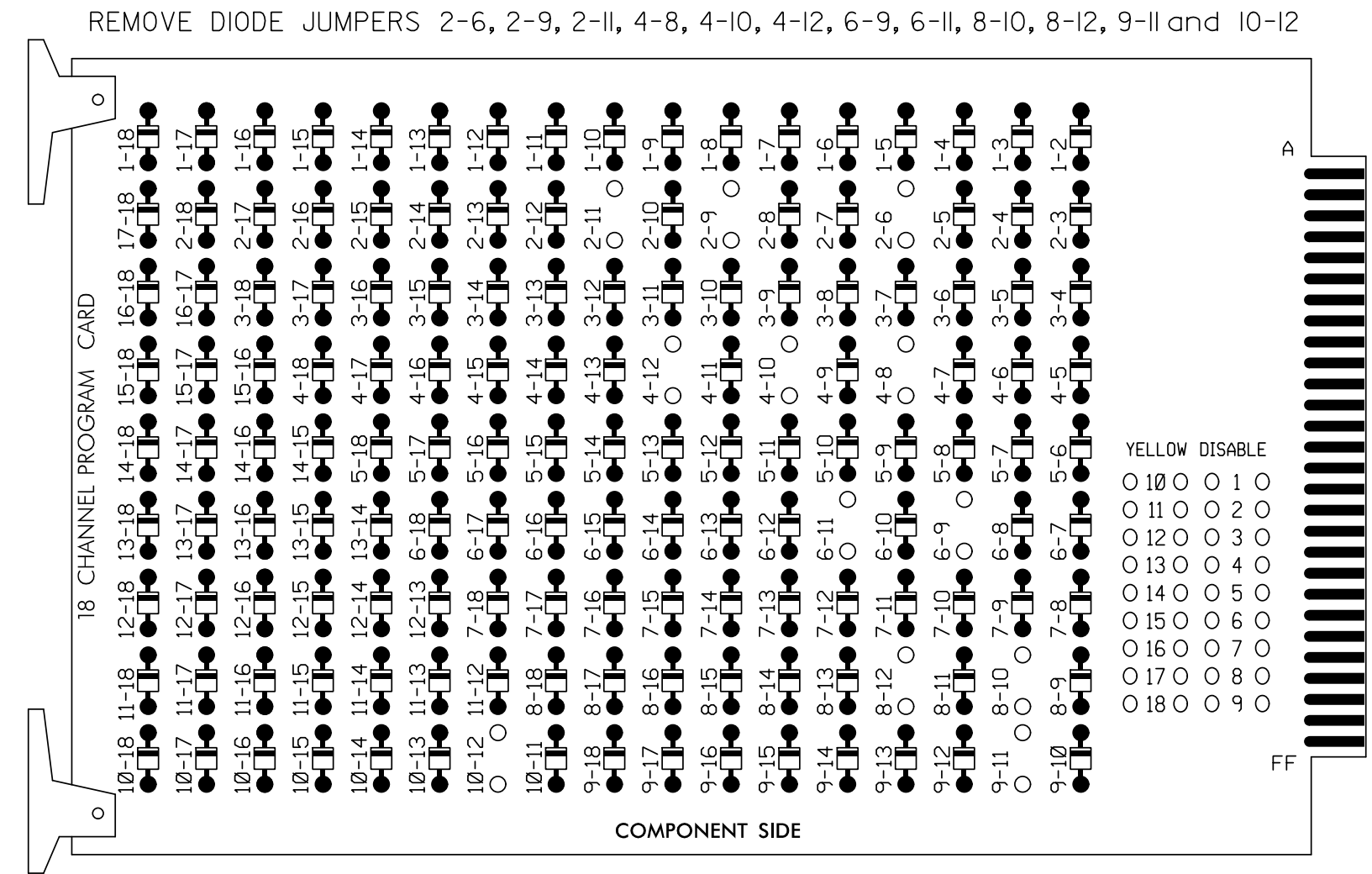

NOTES:

- Card is provided with all diode jumpers in place. Removal of any jumper allows its channels to run concurrently.
- Ensure jumpers SEL2-SEL5 and SEL9 are present on the monitor board.
- Ensure that Red Enable is active at all times during normal operation.
- Connect serial cable from conflict monitor to comm. port 1 of 2070 controller. Ensure conflict monitor communicates with 2070.

INPUT FILE CONNECTION & PROGRAMMING CHART

LOOP NO.	LOOP TERMINAL	INPUT FILE POS.	PIN NO.	INPUT ASSIGNMENT NO.	DETECTOR NO.	NEMA PHASE	CALL	EXTEND	FULL TIME DELAY	STRETCH TIME	DELAY TIME
2A	TB2-5,6	I2U	39	1	2	2	Y	Y			
2B	TB2-7,8	I2L	43	5	12	2	Y	Y	Y		3
4A	TB4-9,10	I6U	41	3	4	4	Y	Y			3
4B	TB4-11,12	I6L	45	7	14	4	Y	Y			10
6A	TB3-5,6	J2U	40	2	6	6	Y	Y			
6B	TB3-7,8	J2L	44	6	16	6	Y	Y	Y		3
8A	TB5-9,10	J6U	42	4	8	8	Y	Y			3
8B	TB5-11,12	J6L	46	8	18	8	Y	Y			10
8C	TB7-1,2	J7U	66	28	38	8	Y	Y			15

INPUT FILE POSITION LEGEND: J2L

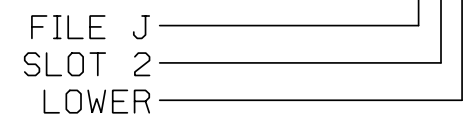

INPUT FILE POSITION LAYOUT

(front view)

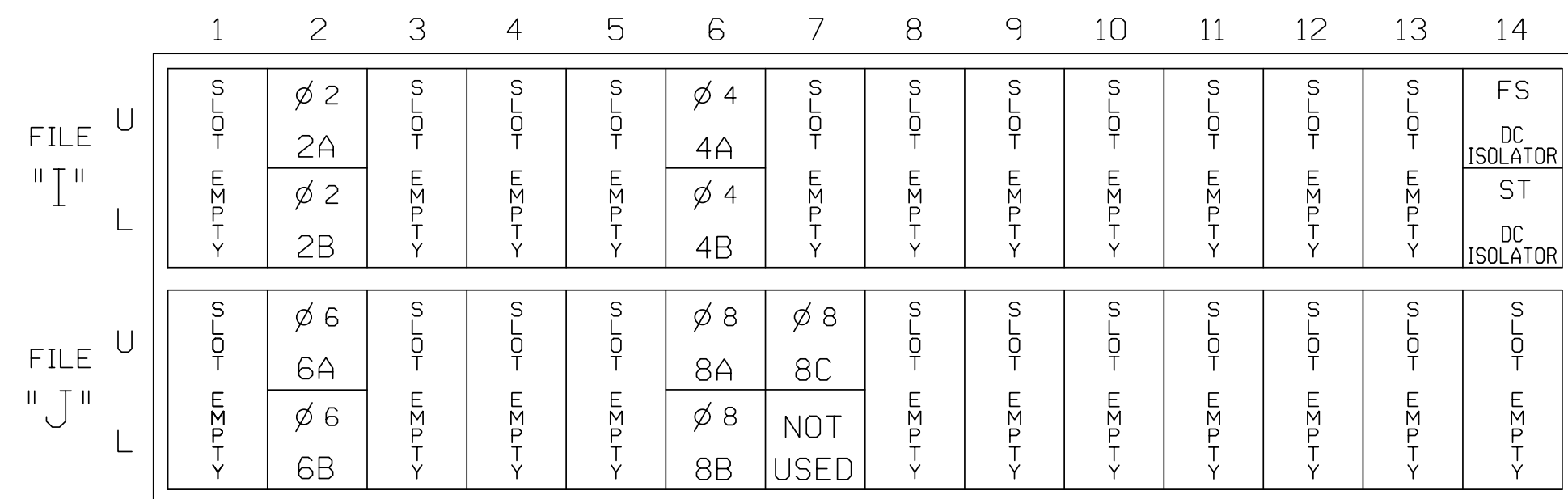

EX.: 1A, 2A, ETC. = LOOP NO.'S

FS = FLASH SENSE
ST = STOP TIME

NOTES

- To prevent "flash-conflict" problems, insert red flash program blocks for all unused vehicle load switches in the output file. The installer shall verify that signal heads flash in accordance with the Signal Plans.
- Program phases 4 and 8 for Dual Entry.
- Enable Simultaneous Gap-Out for all Phases.
- Program phases 2 and 6 for Variable Initial and Gap Reduction.
- Program phases 2 and 6 for Startup In Green.
- Program phases 2 and 6 for Yellow Flash, and overlaps 1 and 2 as Wag Overlaps.
- The cabinet and controller are part of the NC 125 Wireless Closed Loop System.

EQUIPMENT INFORMATION

CONTROLLER.....2070
CABINET.....332 W/ AUX
SOFTWARE.....ECONOLITE OASIS
CABINET MOUNT.....BASE
OUTPUT FILE POSITIONS...18 WITH AUX. OUTPUT FILE
LOAD SWITCHES USED.....S2,S5,S8,S11,AUX S1,AUX S2, AUX S4,AUX S5
PHASES USED.....2,4,6,8
OVERLAP "A".....2
OVERLAP "B".....4
OVERLAP "C".....6
OVERLAP "D".....8

OVERLAP PROGRAMMING DETAIL

(program controller as shown below)

FROM MAIN MENU PRESS '8' (OVERLAPS), THEN '1' (VEHICLE OVERLAP SETTINGS).

PAGE 1: VEHICLE OVERLAP 'A' SETTINGS
PHASE: 12345678910111213141516
VEH OVL PARENTS: X
VEH OVL NOT VEH: X
VEH OVL NOT PED: X
VEH OVL GRN EXT: X
STARTUP COLOR: - RED - YELLOW - GREEN
FLASH COLORS: - RED - YELLOW X GREEN
SELECT VEHICLE OVERLAP OPTIONS: (Y/N)
FLASH YELLOW IN CONTROLLER FLASH?...Y
GREEN EXTENSION (0-255 SEC)...0
YELLOW CLEAR (0=PARENT,3-25.5 SEC)...0.0
RED CLEAR (0=PARENT,0.1-25.5 SEC)...0.0
OUTPUT AS PHASE # (0=NONE, 1-16)...0

NOTICE GREEN FLASH

PRESS '+'

PAGE 1: VEHICLE OVERLAP 'B' SETTINGS
PHASE: 12345678910111213141516
VEH OVL PARENTS: X
VEH OVL NOT VEH: X
VEH OVL NOT PED: X
VEH OVL GRN EXT: X
STARTUP COLOR: - RED - YELLOW - GREEN
FLASH COLORS: - RED - YELLOW X GREEN
SELECT VEHICLE OVERLAP OPTIONS: (Y/N)
FLASH YELLOW IN CONTROLLER FLASH?...N
GREEN EXTENSION (0-255 SEC)...0
YELLOW CLEAR (0=PARENT,3-25.5 SEC)...0.0
RED CLEAR (0=PARENT,0.1-25.5 SEC)...0.0
OUTPUT AS PHASE # (0=NONE, 1-16)...0

NOTICE GREEN FLASH

PRESS '+'

PAGE 1: VEHICLE OVERLAP 'C' SETTINGS
PHASE: 12345678910111213141516
VEH OVL PARENTS: X
VEH OVL NOT VEH: X
VEH OVL NOT PED: X
VEH OVL GRN EXT: X
STARTUP COLOR: - RED - YELLOW - GREEN
FLASH COLORS: - RED - YELLOW X GREEN
SELECT VEHICLE OVERLAP OPTIONS: (Y/N)
FLASH YELLOW IN CONTROLLER FLASH?...Y
GREEN EXTENSION (0-255 SEC)...0
YELLOW CLEAR (0=PARENT,3-25.5 SEC)...0.0
RED CLEAR (0=PARENT,0.1-25.5 SEC)...0.0
OUTPUT AS PHASE # (0=NONE, 1-16)...0

NOTICE GREEN FLASH

PRESS '+'

PAGE 1: VEHICLE OVERLAP 'D' SETTINGS
PHASE: 12345678910111213141516
VEH OVL PARENTS: X
VEH OVL NOT VEH: X
VEH OVL NOT PED: X
VEH OVL GRN EXT: X
STARTUP COLOR: - RED - YELLOW - GREEN
FLASH COLORS: - RED - YELLOW X GREEN
SELECT VEHICLE OVERLAP OPTIONS: (Y/N)
FLASH YELLOW IN CONTROLLER FLASH?...N
GREEN EXTENSION (0-255 SEC)...0
YELLOW CLEAR (0=PARENT,3-25.5 SEC)...0.0
RED CLEAR (0=PARENT,0.1-25.5 SEC)...0.0
OUTPUT AS PHASE # (0=NONE, 1-16)...0

NOTICE GREEN FLASH

OVERLAP PROGRAMMING COMPLETE

THIS ELECTRICAL DETAIL IS FOR THE SIGNAL DESIGN: 05-1220T2
DESIGNED: APRIL 2018
SEALED: 6/12/2018
REVISED: N/A

PLANS PREPARED IN THE OFFICE OF:
KimleyHorn
NC License #F-0102
421 Fayetteville Street, Suite 600
Raleigh, NC 27601
(919) 677-2000

SIGNAL HEAD HOOK-UP CHART

LOAD SWITCH NO.	S1	S2	S3	S4	S5	S6	S7	S8	S9	S10	S11	S12	AUX S1	AUX S2	AUX S3	AUX S4	AUX S5	AUX S6
CMU CHANNEL NO.	1	2	13	3	4	14	5	6	15	7	8	16	9	10	17	11	12	18
PHASE	1	2	2 PED	3	4	4 PED	5	6	6 PED	7	8	8 PED	OLA	OLB	SPARE	OLC	OLD	SPARE
SIGNAL HEAD NO.	NU	22,23	NU	NU	42,43	NU	NU	62,63	NU	NU	82,83	NU	61	81	NU	21	41	NU
RED		128			101			134			107							
YELLOW		129			102			135			108							
GREEN		130			103			136			109							
RED ARROW														A121	A124		A114	A101
YELLOW ARROW														A122	A125		A115	A102
FLASHING YELLOW ARROW														A123	A126		A116	A103
GREEN ARROW																		

NU = Not Used

* See pictorial of head wiring in detail this sheet.

FYA SIGNAL WIRING DETAIL

(wire signal heads as shown)

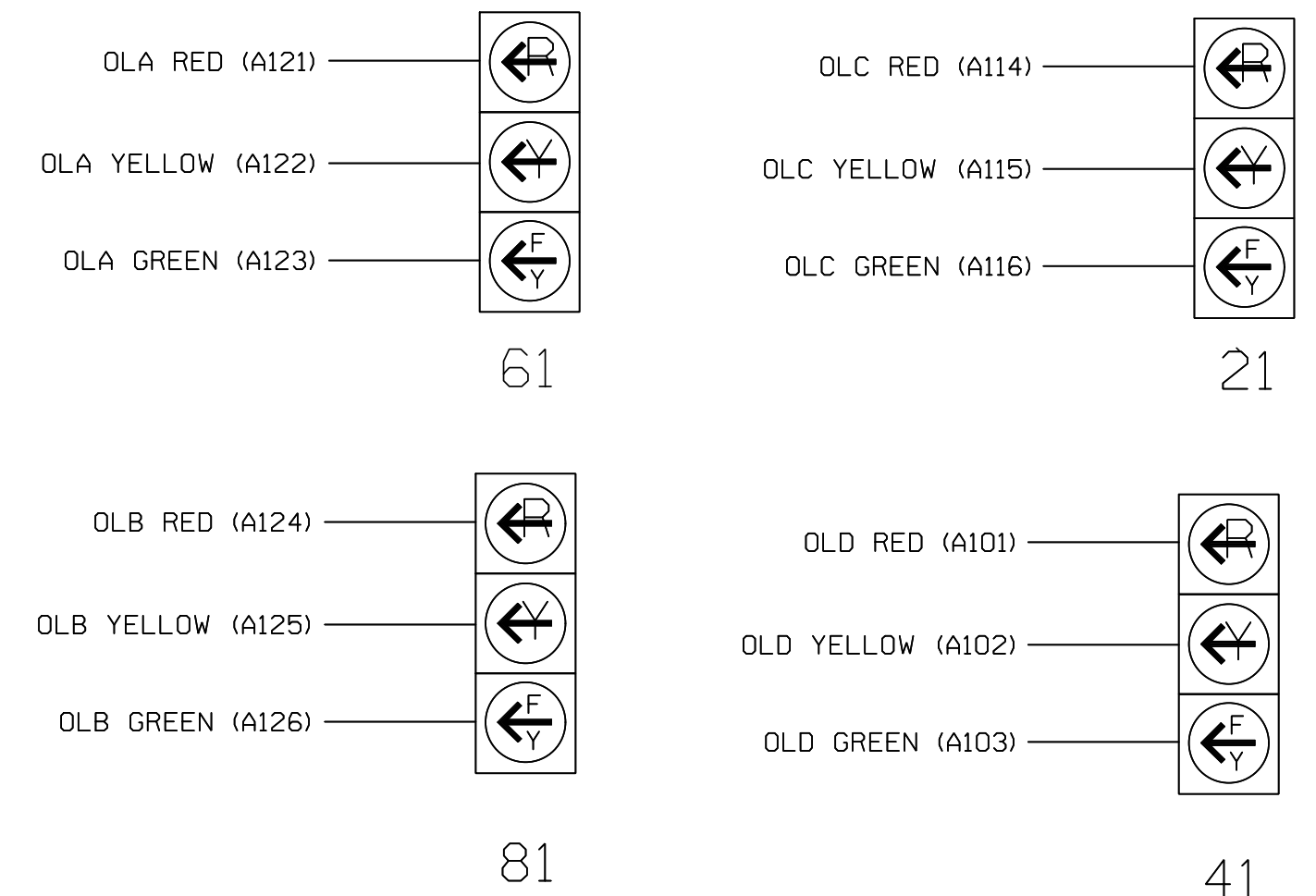

FLASHER CIRCUIT MODIFICATION DETAIL

In order to ensure that signals flash concurrently on the same approach, make the following flasher circuit changes:

- On rear of PDA - remove wire from Term. T2-4 and terminate on T2-2.
- On rear of PDA - remove wire from Term. T2-5 and terminate on T2-3.
- Remove flasher unit 2.

The changes listed above ties all phases and overlaps to flasher unit 1.

TEMPORARY DESIGN 2-TC PLAN PHASE 3 ELECTRICAL DETAIL

DOCUMENT NOT CONSIDERED FINAL UNLESS ALL SIGNATURES COMPLETED

SEAL

SEAL NORTH CAROLINA PROFESSIONAL ENGINEER STATE OF NORTH CAROLINA

SEAL 032607

SEAL 6/12/2018

SEAL SIGNATURE

DATE

SIG. INVENTORY NO. 04-1220T2

Prepared For: **KimleyHorn**

NC License #F-0102

421 Fayetteville Street, Suite 600

Raleigh, NC 27601

(919) 677-2000

PLANS PREPARED IN THE OFFICE OF:

750 N. Greenfield Pkwy, Garner, NC 27529

NC 125 AT SR 1627 (THREE BRIDGES ROAD) / PREMIER BOULEVARD EXT.

DIVISION 4 HALIFAX COUNTY ROANOKE RAPIDS

PLAN DATE: APRIL 2018 REVIEWED BY: SL PHILLIPS

PREPARED BY: SP PENNINGTON REVIEWED BY:

REVISIONS INIT. DATE