

STATE OF NORTH CAROLINA
DEPT. OF TRANSPORTATION
DIVISION OF HIGHWAYS
RALEIGH, N.C.

ENGLISH DETAIL DRAWING FOR
**MINIMUM DEPTH
CONCRETE CATCH BASIN**
12" THRU 84" PIPE

SHEET 1 OF 2
840D02

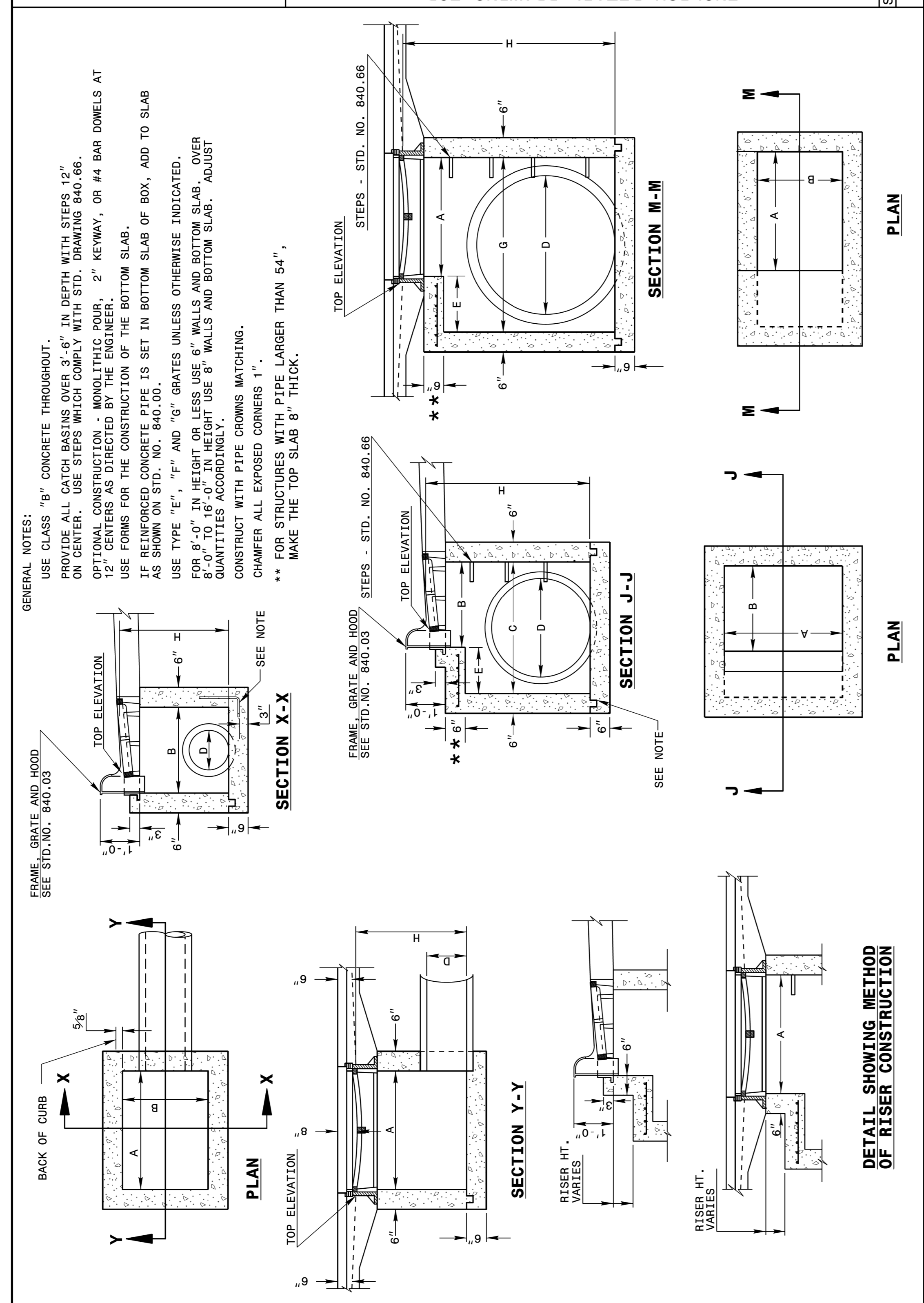

STATE OF NORTH CAROLINA
DEPT. OF TRANSPORTATION
DIVISION OF HIGHWAYS
RALEIGH, N.C.

ENGLISH DETAIL DRAWING FOR
**MINIMUM DEPTH
CONCRETE CATCH BASIN**
12" THRU 84" PIPE

SHEET 1 OF 2
840D02

STATE OF NORTH CAROLINA
DEPT. OF TRANSPORTATION
DIVISION OF HIGHWAYS
RALEIGH, N.C.

ENGLISH DETAIL DRAWING FOR
**MINIMUM DEPTH
CONCRETE CATCH BASIN**
12" THRU 84" PIPE

SHEET 2 OF 2
840D02

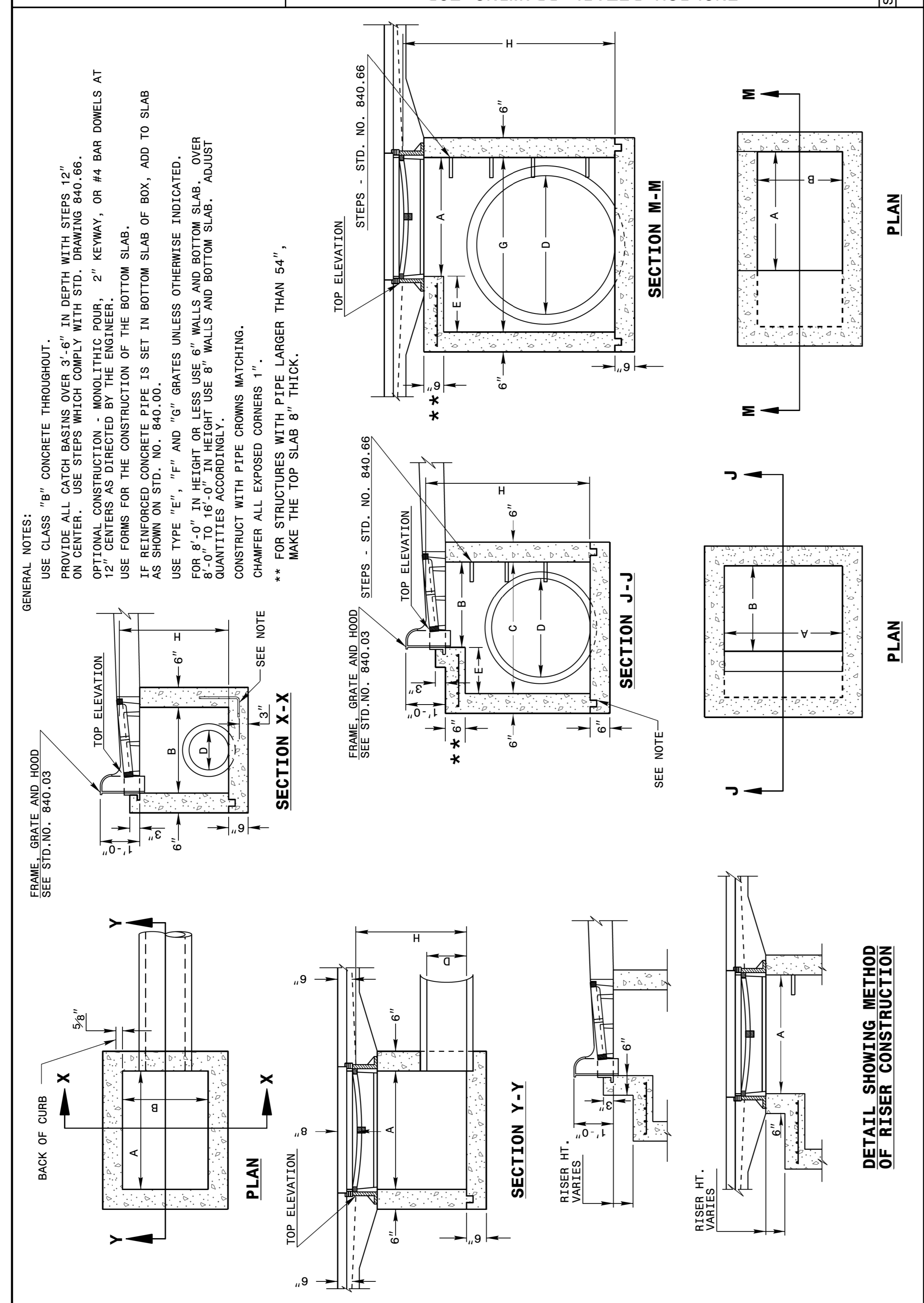

STATE OF NORTH CAROLINA
DEPT. OF TRANSPORTATION
DIVISION OF HIGHWAYS
RALEIGH, N.C.

ENGLISH DETAIL DRAWING FOR
**MINIMUM DEPTH
CONCRETE CATCH BASIN**
12" THRU 84" PIPE

SHEET 2 OF 2
840D02

STATE OF NORTH CAROLINA
DEPT. OF TRANSPORTATION
DIVISION OF HIGHWAYS
RALEIGH, N.C.

ENGLISH DETAIL DRAWING FOR
**MINIMUM DEPTH
CONCRETE CATCH BASIN**
12" THRU 84" PIPE

SHEET 2 OF 2
840D02

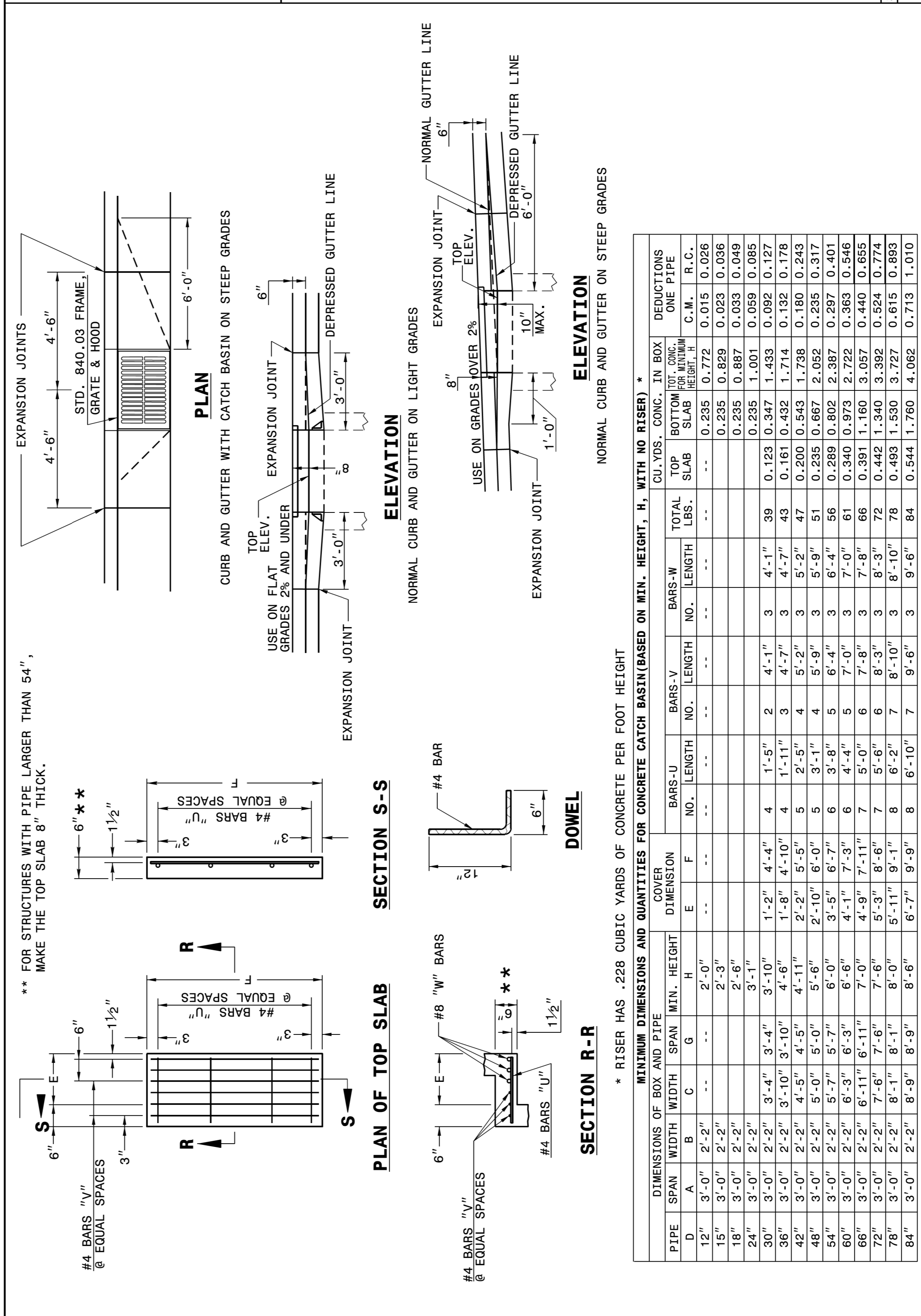

STATE OF NORTH CAROLINA
DEPT. OF TRANSPORTATION
DIVISION OF HIGHWAYS
RALEIGH, N.C.

ENGLISH DETAIL DRAWING FOR
**MINIMUM DEPTH
CONCRETE CATCH BASIN**
12" THRU 84" PIPE

SHEET 2 OF 2
840D02

CONTRACT STANDARDS AND DEVELOPMENT UNIT
Office 919-707-6950 FAX 919-250-4119

SEE PLATE FOR TITLE

ORIGINAL BY: 2002 Std.840.01 DATE: _____
MODIFIED BY: E.E. WARD DATE: 3-1-02
CHECKED BY: _____ DATE: _____
FILE SPEC.: s:Special Details/jhowerton/840d02.dgn