

**This electronic collection of documents is provided
for the convenience of the user
and is Not a Certified Document –**

**The documents contained herein were originally issued
and sealed by the individuals whose names and license
numbers appear on each page, on the dates appearing
with their signature on that page.**

**This file or an individual page
shall not be considered a certified document.**

TIP PROJECT: U-4405

CONTRACT: C204107

STATE OF NORTH CAROLINA
DIVISION OF HIGHWAYS

CUMBERLAND COUNTY

LOCATION: US 401 FROM WEST OF HAPTON OAKS DRIVE TO EAST OF FAIRWAY DRIVE IN FAYETTEVILLE

TYPE OF WORK: GRADING, DRAINAGE, PAVING, SIGNALS, WIDENING, RESURFACING, STRUCTURE, RETAINING WALLS, AND NOISE WALLS

STATE	STATE PROJECT REFERENCE NO.	SHEET NO.	TOTAL SHEETS
N.C.	U-4405	1	26
STATE PROJ. NO.	F.A. PROJ. NO.	DESCRIPTION	
39049.1.1	STPDA-0401(230)	PE	
39049.2.1	STPDA-0401(230)	RW	
39049.2.1	STPDA-0401(230)	UTIL	
39049.3.1	STPDA-0401(230)	CONST	

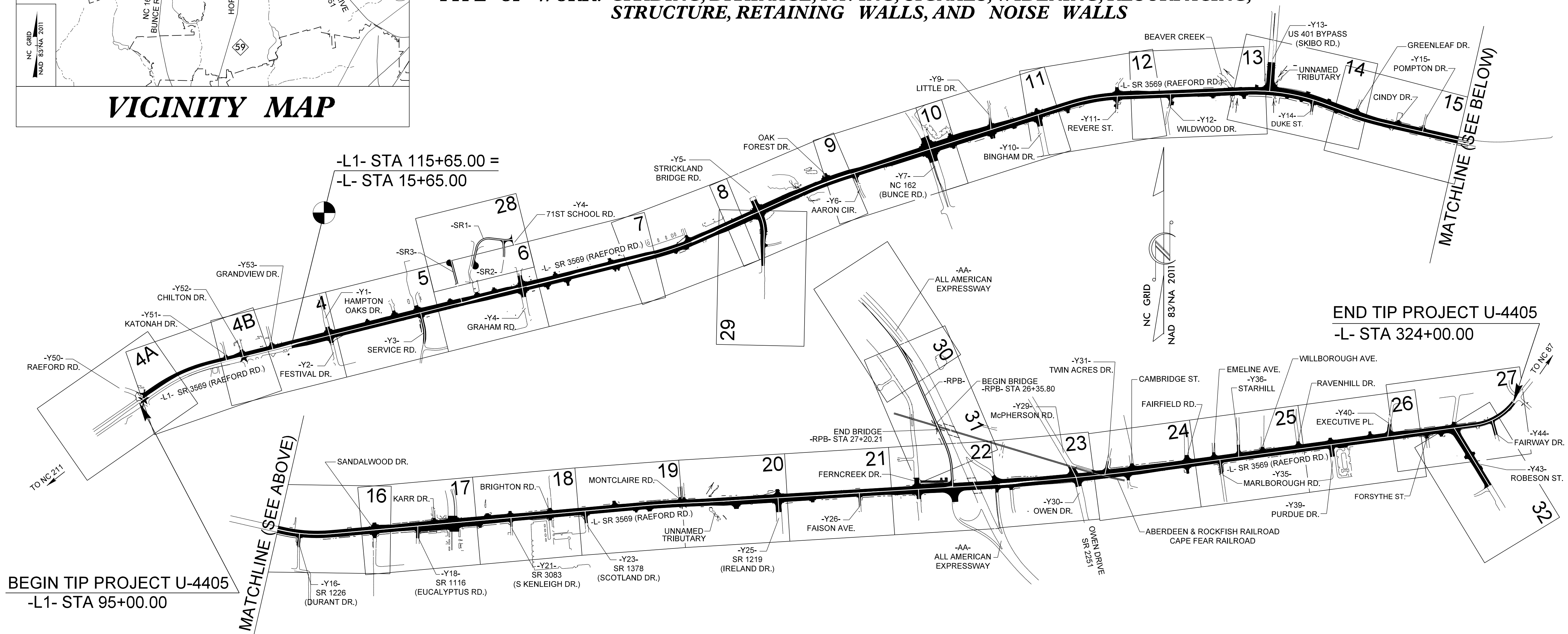
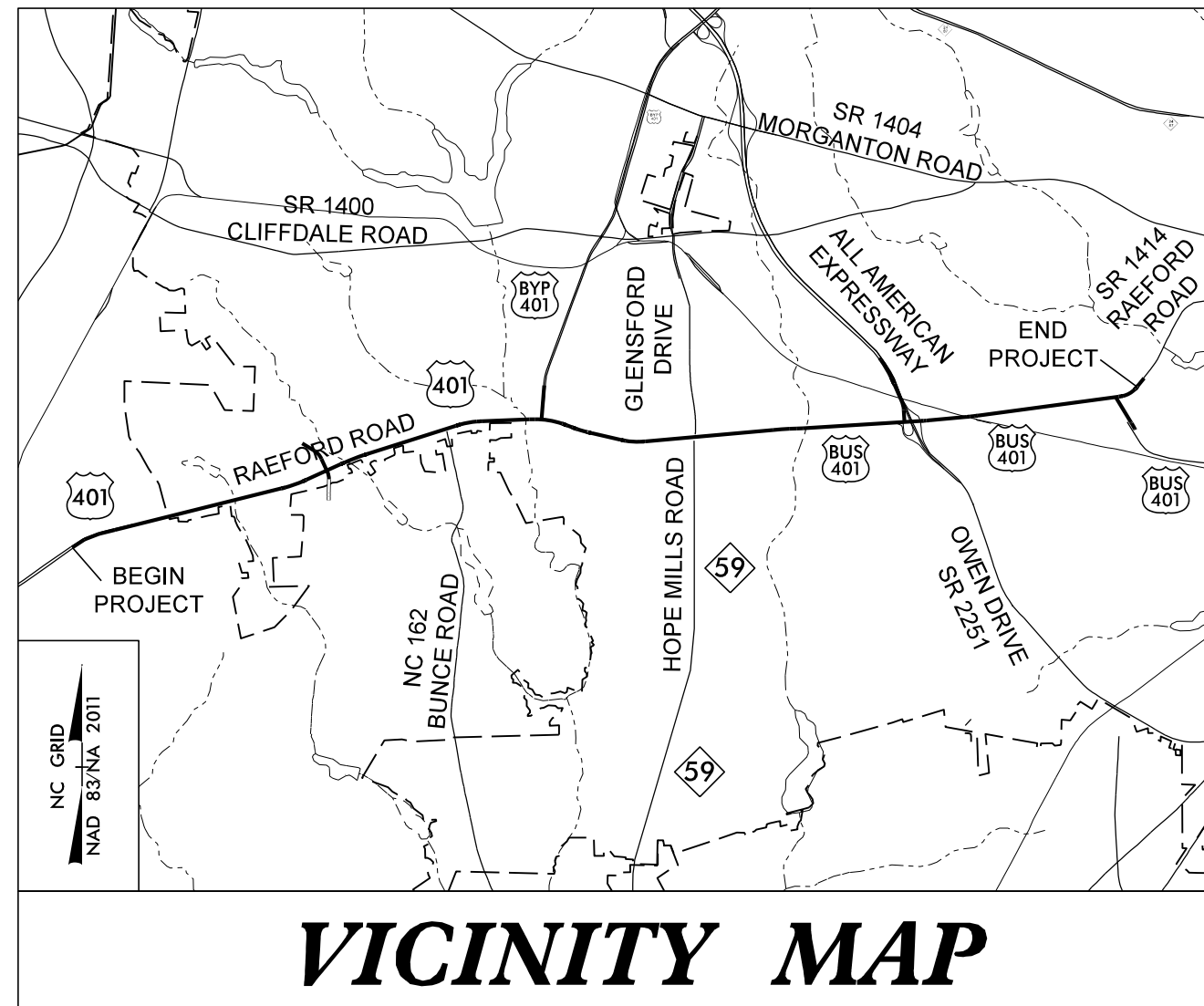

THIS PROJECT IS WITHIN THE MUNICIPAL BOUNDARIES OF THE CITY OF FAYETTEVILLE.
CLEARING ON THIS PROJECT SHALL BE PERFORMED TO THE LIMITS ESTABLISHED BY METHOD II .
**** A DESIGN EXCEPTION FOR LANE WIDTH IS REQUIRED**

STRUCTURES

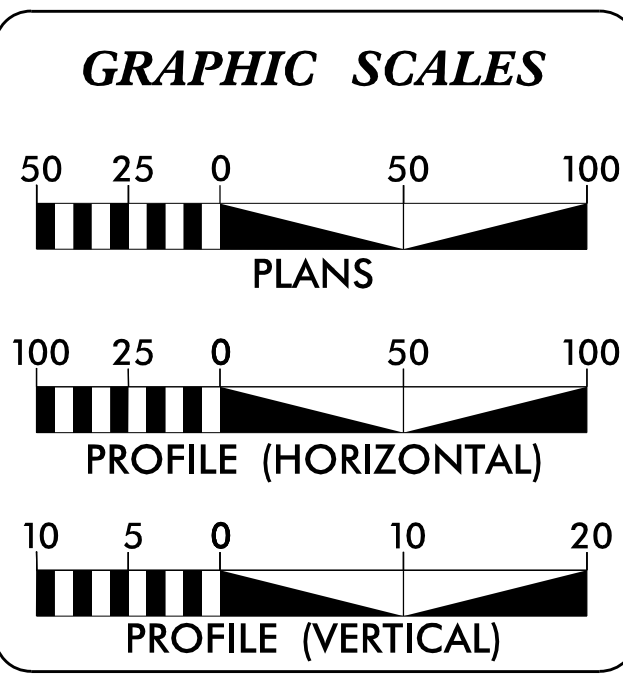

DESIGN DATA

ADT 2018 =	63,150
ADT 2038 =	70,975
K =	10 %
D =	60 %
T =	3%*
V =	50 MPH
*TTST =	1% DUAL=2%
FUNC CLASS =	URBAN ARTERIAL
REGIONAL TIER	REGIONAL TIER

PROJECT LENGTH

LENGTH ROADWAY TIP PROJECT U-4405 =	6.231 MILES
TOTAL LENGTH TIP PROJECT U-4405 =	6.231 MILES

NCDOT CONTACT: BRENDA MOORE, PE

Prepared for Division of Highways in the Office of:

KCA
KISINGER CAMPO & ASSOCIATES
4800 SIX FORKS ROAD SUITE 120
RALEIGH, NC 27609
(919) 882-7839

2018 STANDARD SPECIFICATIONS

RIGHT OF WAY DATE: TIERRE R. PETERSON, PE
PROJECT ENGINEER

LETTING DATE: SEPTEMBER 18, 2018

KANAK PUROHIT, PE
PROJECT DESIGN ENGINEER

STRUCTURES MANAGEMENT UNIT

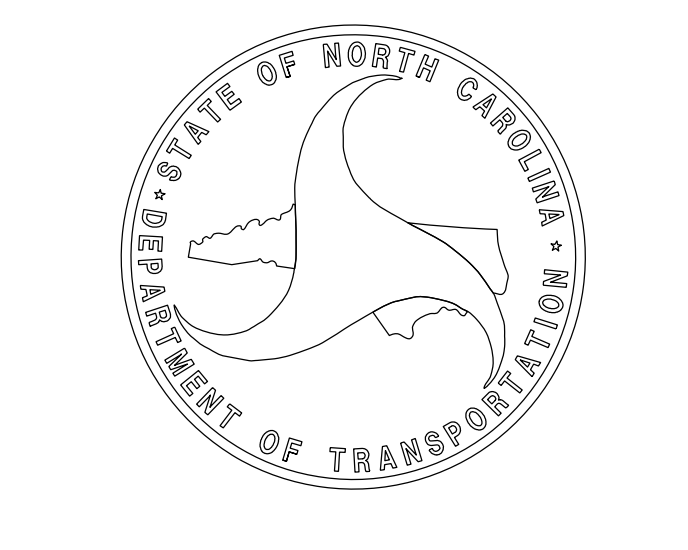

GRADE DATA -RPB-

+3.7124% -4.6282%
 PI = 26+75.00
 EL = 242.83'
 VC = 715'

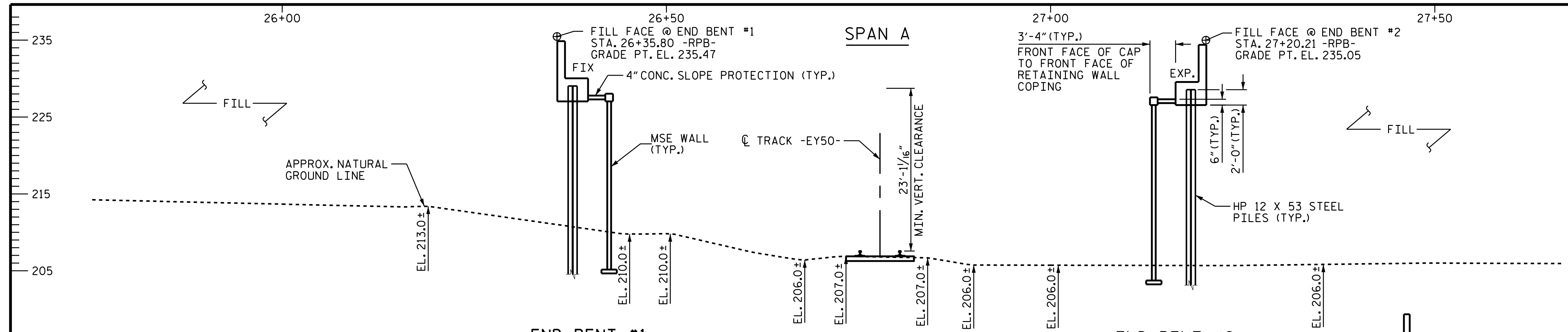

TOP OF RAIL ELEVATIONS

TRACK STATION	LEFT RAIL	RIGHT RAIL
19+80	207.307	207.416
20+00	207.276	207.383
20+20	207.248	207.350
20+40	207.221	207.317
20+60	207.188	207.284

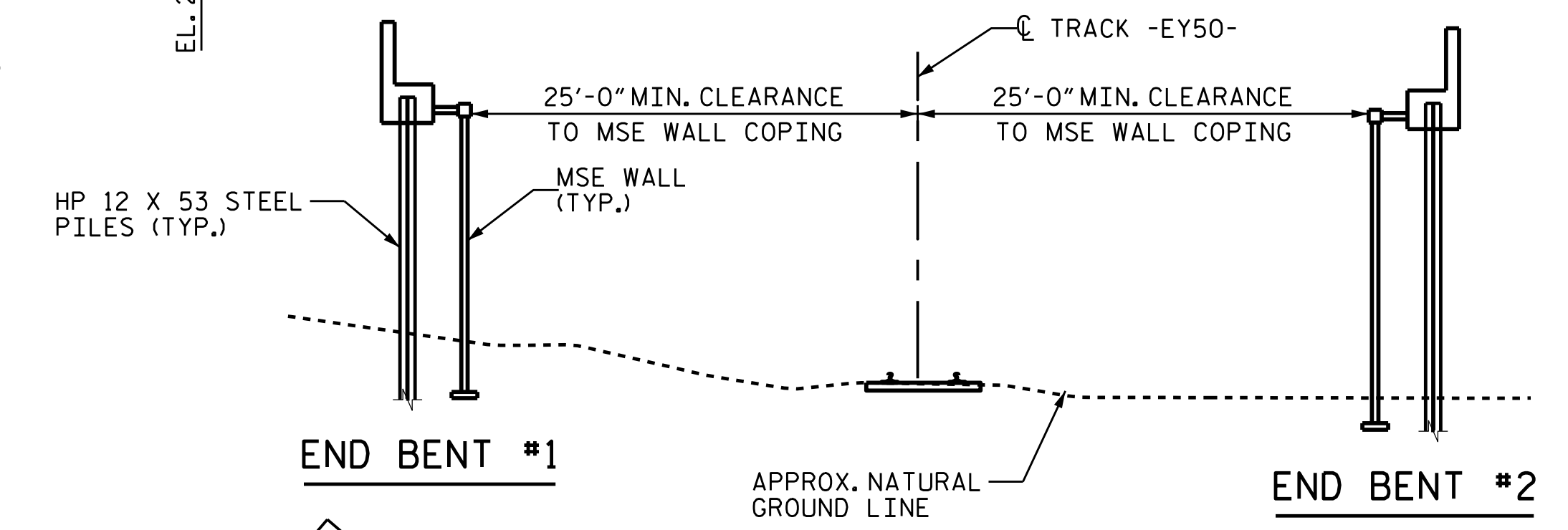

SECTION THRU RAILROAD
 LOOKING IN DIRECTION OF INCREASING MILE POST ALONG RAILROAD
 (SPAN LENGTH IS BASED ON THIS SECTION)

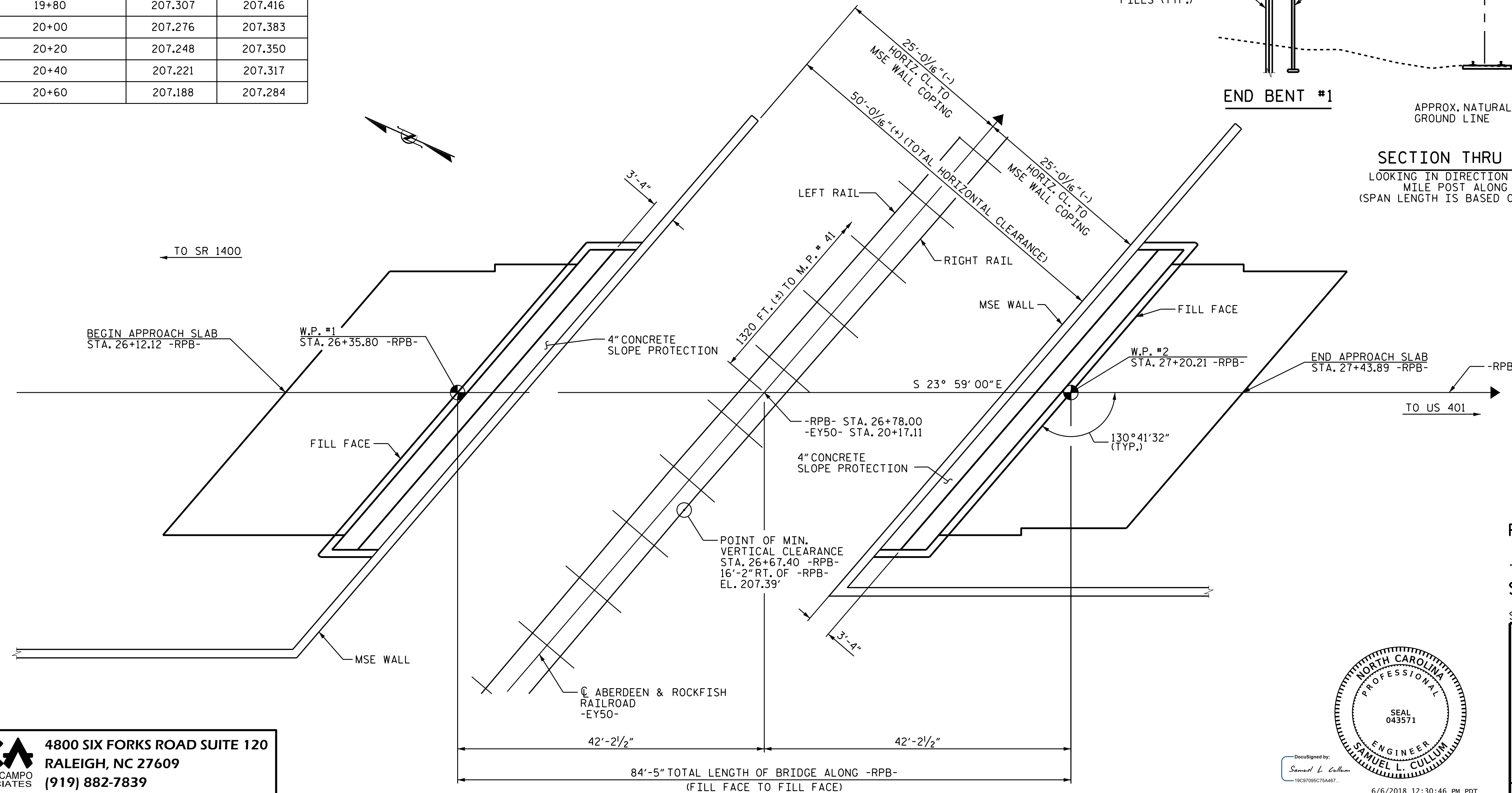

PLAN

PILES NOT SHOWN IN THE PLAN VIEW FOR CLARITY

KCA 4800 SIX FORKS ROAD SUITE 120
 KISINGER CAMPO & ASSOCIATES RALEIGH, NC 27609
 (919) 882-7839

DRAWN BY: J. HANNA DATE: 05-17
 CHECKED BY: L. MARTINEZ DATE: 05-17
 DESIGN ENGINEER OF RECORD: S. CULLUM DATE: 05-17

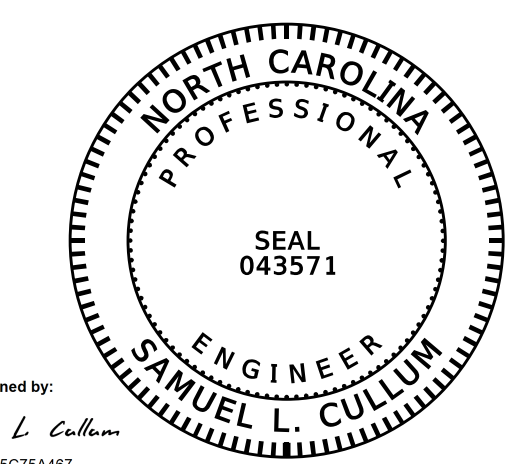

6/6/2018 12:30:46 PM PDT

DOCUMENT NOT CONSIDERED FINAL UNLESS ALL SIGNATURES COMPLETED

PROJECT NO. U-4405
 CUMBERLAND COUNTY
 STATION: 26+78.00 -RPB-

SHEET 1 OF 3 BRIDGE NO. 440 MILE POST 40.75

REVISIONS						SHEET NO.
NO.	BY:	DATE:	NO.	BY:	DATE:	S-1
1			3			TOTAL SHEETS
2			4			26

FOUNDATION NOTES:

1. FOR PILES, SEE SPECIAL PROVISIONS AND SECTION 450 OF THE STANDARD SPECIFICATIONS.
2. PILES AT END BENT No.1 AND END BENT No.2 ARE DESIGNED FOR A FACTORED RESISTANCE OF 105 TONS PER PILE.
3. DRIVE PILES AT END BENT No.1 AND END BENT No.2 TO A A REQUIRED DRIVING RESISTANCE OF 175 TONS PER PILE.
4. TESTING PILES WITH THE PDA DURING DRIVING, RESTRIKING OR REDRIVING MAY BE REQUIRED. THE ENGINEER WILL DETERMINE THE NEED FOR PDA TESTING. FOR PDA TESTING, SEE SECTION 450 OF THE STANDARD SPECIFICATIONS.

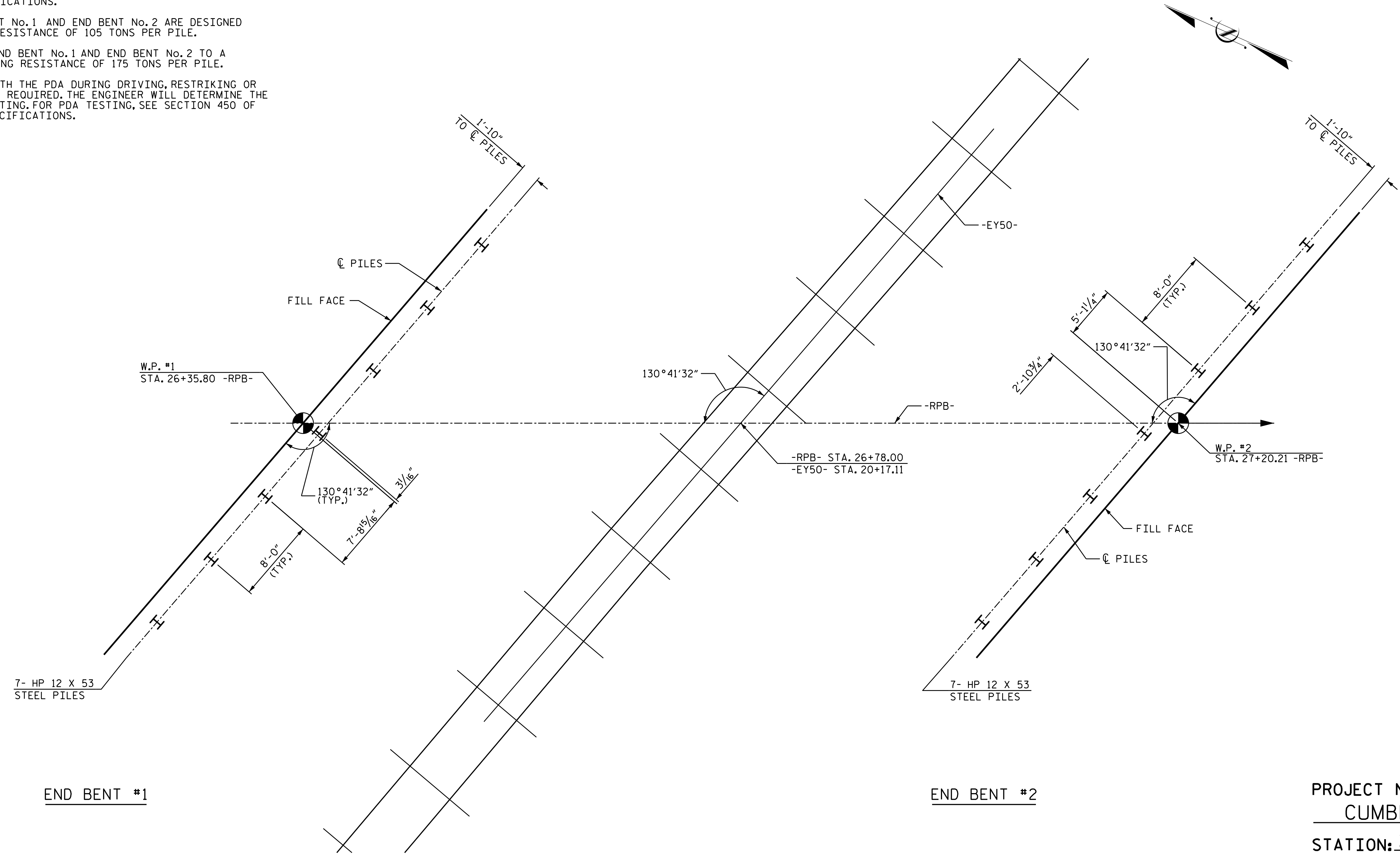

FOUNDATION LAYOUT

DIMENSIONS LOCATING PILES ARE SHOWN TO PILE CENTERLINE. END BENTS ARE PARALLEL TO THE RAILWAY.

PROJECT NO. U-4405
CUMBERLAND COUNTY
 STATION: 26+78.00 -RPB-

SHEET 2 OF 3

KCA 4800 SIX FORKS ROAD SUITE 120
 KISINGER CAMPO & ASSOCIATES RALEIGH, NC 27609
 (919) 882-7839

DRAWN BY :	J. B. HANNA	DATE :	05-17
CHECKED BY :	L. MARTINEZ	DATE :	05-17
DESIGN ENGINEER OF RECORD:	S. CULLUM	DATE :	05-17

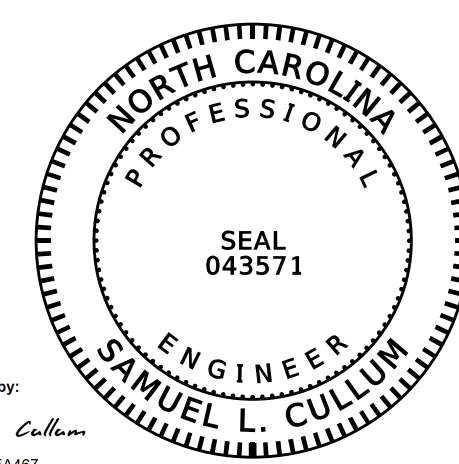

DocuSigned by:
 Samuel L. Cullum
 19C97095C75A467...

6/6/2018 12:30:46 PM PDT

DOCUMENT NOT CONSIDERED FINAL UNLESS ALL SIGNATURES COMPLETED

STATE OF NORTH CAROLINA
 DEPARTMENT OF TRANSPORTATION
 RALEIGH

GENERAL DRAWING
 FOR BRIDGE ON RAMP B
 OVER ABERDEEN AND
 ROCKFISH RAILROAD
 BETWEEN SR 1400 AND US 401

REVISIONS						SHEET NO.
NO.	BY:	DATE:	NO.	BY:	DATE:	S-2
1			3			TOTAL SHEETS
2			4			26

BM. #13 - BENCH TIE IN POWER POLE, 275' RT. OF -L- STA. 247+67.00, ELEV. 213.28

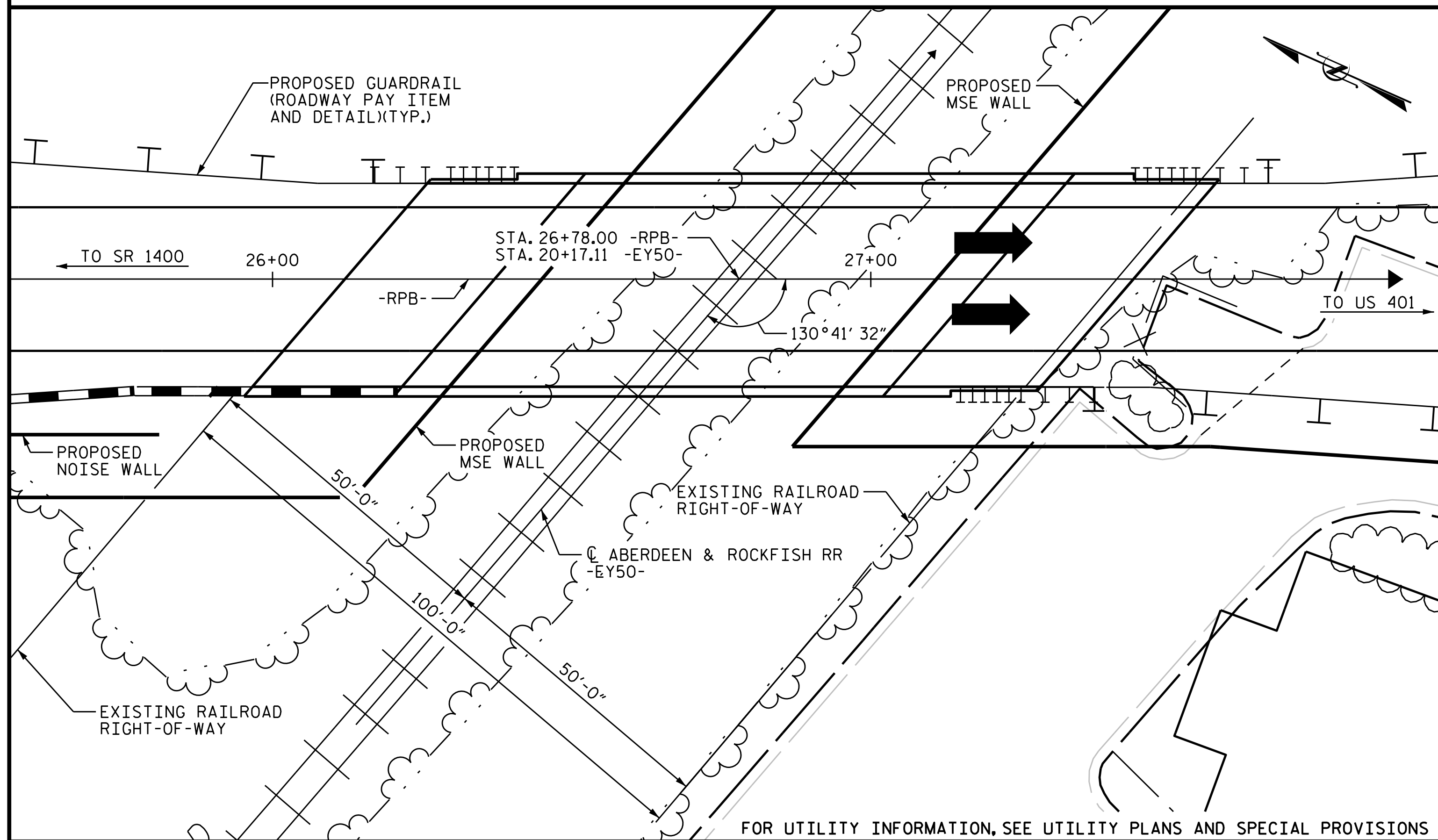

LOCATION SKETCH

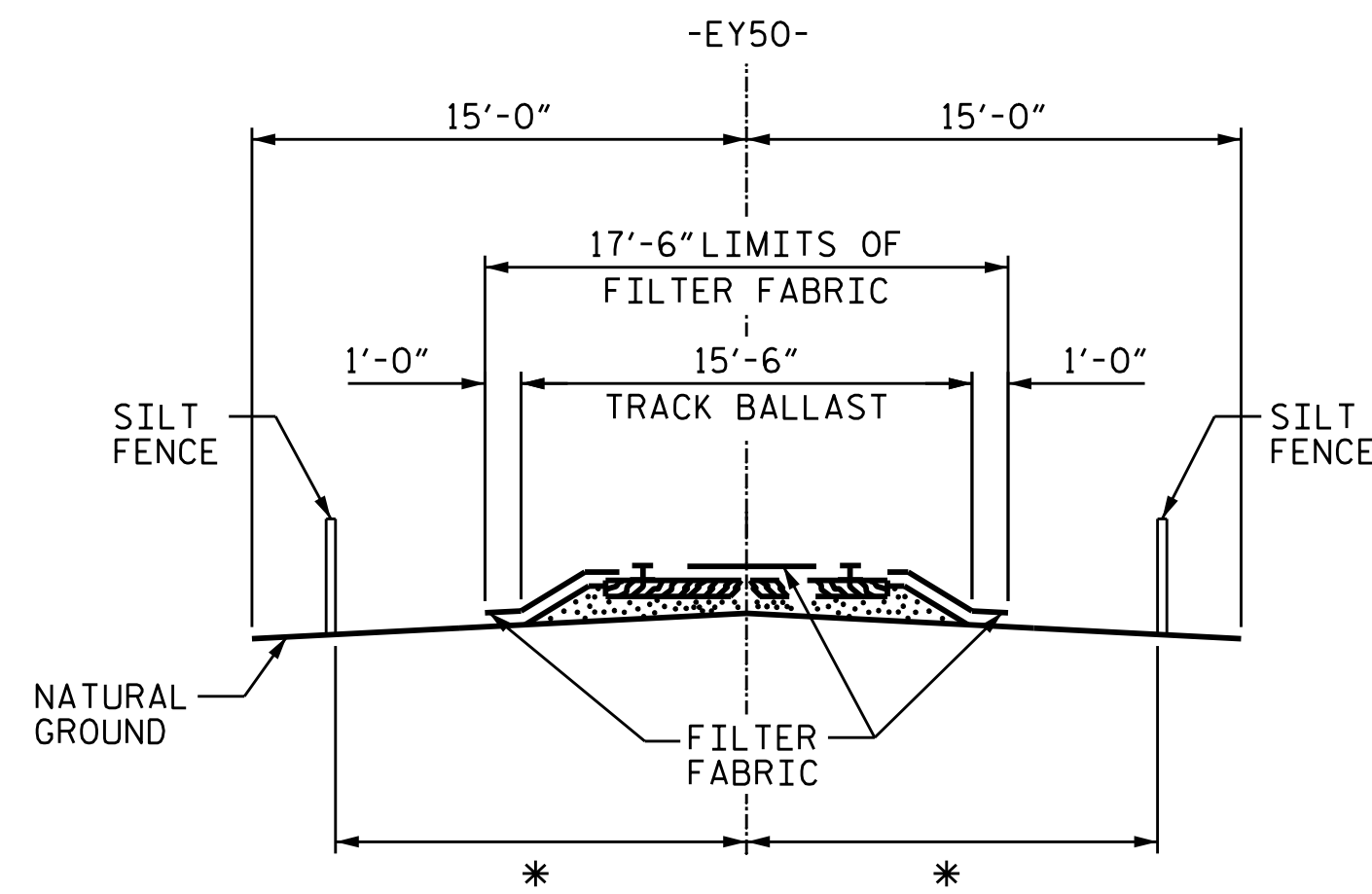

RAILROAD EROSION CONTROL DETAIL

* TO BE DETERMINED BY THE RESIDENT ENGINEER IN CONSULTATION WITH RAILROAD ENGINEER

NOTES

- RAILROAD EROSION CONTROL MEASURES SHALL BE INSTALLED PRIOR TO PERFORMING ANY WORK IN THE RAILROAD RIGHT-OF-WAY.
- ADDITIONAL EROSION CONTROL MEASURES FOR PROTECTION OF RAILROAD DITCHES MAY BE REQUIRED AS DIRECTED BY THE ENGINEER.
- NO SEPERATE PAYMENT WILL BE MADE FOR RAILROAD EROSION CONTROL MEASURES.
- LIMITS OF SILT FENCE AND FILTER FABRIC PARALLEL TO RAILROAD SHALL EXTEND A MINIMUM OF 25'-0" OUTSIDE EDGE OF SUPERSTRUCTURE OR TOE OF SLOPE ON CONSTRUCTION. A GREATER LENGTH OF SILT FENCE OR FILTER FABRIC MAY BE REQUIRED IF SO DIRECTED BY THE ENGINEER.
- FILTER FABRIC TO BE NAILED TO TIMBER RAIL TIES WITH PRIME SOURCE "GRIP CAP" OR EQUIVALENT. FILTER FABRIC ON SHOULDER TO BE SECURED AS DIRECTED BY THE ENGINEER AND RAILROAD.

TOTAL BILL OF MATERIAL

	PDA TESTING	REINFORCED CONCRETE DECK SLAB	GROOVING BRIDGE FLOORS	CLASS A CONCRETE	BRIDGE APPROACH SLABS	REINFORCING STEEL	45" PRESTRESSED CONCRETE GIRDER		HP 12 X 53 STEEL PILES		PILE REDRIVES	PILE DRIVING EQUIPMENT SETUP FOR HP 12x53 STEEL PILES	CONCRETE BARRIER RAIL	4" CONCRETE SLOPE PROTECTION	ELASTOMERIC BEARINGS	EXPANSION JOINT SEALS
	EACH	SO.FT.	SO.FT.	CU.YDS.	LUMP SUM	LBS.	NO.	LIN. FT.	NO.	LIN.FT.	EACH	EACH	LIN. FT.	SO. YDS.	LUMP SUM	LUMP SUM
SUPERSTRUCTURE		3,042	4,473		LUMP SUM		5	396.88					220.3		LUMP SUM	LUMP SUM
END BENT NO. 1				45.2		6,468			7	630.0	4	7		14		
END BENT NO. 2				44.3		6,376			7	595.0	4	7		14		
TOTAL	1	3,042	4,473	89.5	LUMP SUM	12,844	5	396.88	14	1225.0	8	14	220.3	28	LUMP SUM	LUMP SUM

NOTES:

- ASSUMED LIVE LOAD = HL-93 OR ALTERNATE LOADING.
- THIS BRIDGE HAS BEEN DESIGNED IN ACCORDANCE WITH THE AASHTO LRFD BRIDGE DESIGN SPECIFICATIONS.
- THIS BRIDGE IS LOCATED IN SEISMIC ZONE 1.
- FOR OTHER DESIGN DATA AND GENERAL NOTES, SEE SHEET SN.
- FOR SUBMITTAL OF WORKING DRAWINGS, SEE SPECIAL PROVISIONS.
- FOR FALSEWORK AND FORMWORK, SEE SPECIAL PROVISIONS.
- FOR CRANE SAFETY, SEE SPECIAL PROVISIONS.
- THE CONTRACTOR SHALL PROVIDE INDEPENDENT ASSURANCE SAMPLES OF REINFORCING STEEL AS FOLLOWS: FOR PROJECTS REQUIRING UP TO 400 TONS OF REINFORCING STEEL, ONE 30" SAMPLE OF EACH SIZE BAR USED, AND FOR PROJECTS REQUIRING OVER 400 TONS OF REINFORCING STEEL, TWO 30" SAMPLES OF EACH SIZE BAR USED. THE BARS FROM WHICH THE SAMPLES ARE TAKEN MUST BE THEN SPICED WITH REPLACEMENT BARS OF THE SIZE AND LENGTH OF THE SAMPLE, PLUS A MINIMUM LAP SPLICE OF THIRTY BAR DIAMETERS. PAYMENT FOR THE SAMPLES OF REINFORCING STEEL SHALL BE CONSIDERED INCIDENTAL TO VARIOUS PAY ITEMS.
- FOR GROUT FOR STRUCTURES, SEE SPECIAL PROVISIONS.

- REMOVABLE FORMS MAY BE USED IN LIEU OF METAL STAY-IN-PLACE FORMS IN ACCORDANCE WITH ARTICLE 420-3 OF THE STANDARD SPECIFICATIONS.
- THE RAILROAD TRACK TOP OF RAIL ELEVATIONS ON THE PLANS ARE FROM THE BEST INFORMATION AVAILABLE. PRIOR TO BEGINNING BRIDGE CONSTRUCTION, VERIFY THE TOP OF RAIL ELEVATIONS AND REPORT ANY VARIATIONS TO THE ENGINEER. ANY PLAN REVISIONS NECESSARY TO ACHIEVE THE REQUIRED MINIMUM CLEARANCE WILL BE PROVIDED BY THE DEPARTMENT.
- NEEDLE BEAMS WILL NOT BE ALLOWED UNLESS OTHERWISE CALLED FOR ON THE PLANS OR APPROVED BY THE ENGINEER.
- FOR EROSION CONTROL MEASURES, SEE EROSION CONTROL PLANS.
- PRESTRESSED CONCRETE DECK PANELS MAY BE USED IN LIEU OF METAL STAY-IN-PLACE FORMS IN ACCORDANCE WITH ARTICLE 420-3 OF THE STANDARD SPECIFICATIONS.
- IF PRESTRESSED CONCRETE DECK PANELS ARE USED, THE SKEWED END CONDITIONS ARE SUCH THAT THE USE OF 4' WIDE PRESTRESSED CONCRETE DECK PANELS ARE NOT POSSIBLE; USE OF 8' WIDE PRESTRESSED CONCRETE DECK PANELS IS NECESSARY.
- FOR PRESTRESSED CONCRETE GIRDERS, SEE SPECIAL PROVISIONS.

PROJECT NO. U-4405
CUMBERLAND COUNTY
 STATION: 26+78.00 -RPB-

SHEET 3 OF 3

KCA 4800 SIX FORKS ROAD SUITE 120
 KISINGER CAMPO & ASSOCIATES RALEIGH, NC 27609
 (919) 882-7839

DRAWN BY : J. B. HANNA DATE : 05-17
 CHECKED BY : L. MARTINEZ DATE : 05-17
 DESIGN ENGINEER OF RECORD: S. CULLUM DATE : 05-17

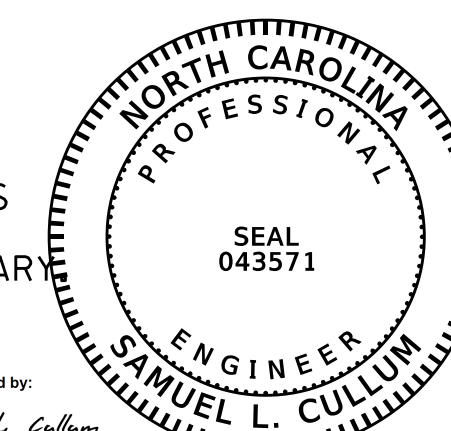

6/6/2018 12:30:46 PM PDT

DOCUMENT NOT CONSIDERED FINAL UNLESS ALL SIGNATURES COMPLETED

STATE OF NORTH CAROLINA
 DEPARTMENT OF TRANSPORTATION
 RALEIGH

GENERAL DRAWING
 FOR BRIDGE ON RAMP B
 OVER ABERDEEN AND
 ROCKFISH RAILROAD
 BETWEEN SR 1400 AND US 401

REVISIONS						SHEET NO.
NO.	BY:	DATE:	NO.	BY:	DATE:	S-3
1			3			TOTAL SHEETS
2			4			26

LOAD FACTORS:

DESIGN LOAD RATING FACTORS	LIMIT STATE	γ_{DC}	γ_{DW}
	STRENGTH I	1.25	1.50
	SERVICE III	1.00	1.00

LOAD AND RESISTANCE FACTOR RATING (LRFR) SUMMARY FOR PRESTRESSED CONCRETE GIRDERS																								
LEVEL	VEHICLE	WEIGHT (W) (TONS)	CONTROLLING LOAD RATING #	MINIMUM RATING FACTORS (RF)	TONS = W x RF	STRENGTH I LIMIT STATE										SERVICE III LIMIT STATE					COMMENT NUMBER			
						MOMENT					SHEAR					MOMENT								
						LIVE-LOAD FACTORS (γ_{LL})	DISTRIBUTION FACTORS (DF)	RATING FACTOR	SPAN	GIRDER LOCATION	DISTANCE FROM LEFT END OF SPAN (ft)	DISTRIBUTION FACTORS (DF)	RATING FACTOR	SPAN	GIRDER LOCATION	DISTANCE FROM LEFT END OF SPAN (ft)	LIVE-LOAD FACTORS (γ_{LL})	DISTRIBUTION FACTORS (DF)	RATING FACTOR	SPAN		GIRDER LOCATION	DISTANCE FROM LEFT END OF SPAN (ft)	
DESIGN LOAD RATING	HL-93 (INVENTORY)	N/A	①	1.07	--	1.75	0.666	1.09	A	EL	39.0	0.913	1.28	A	I	31.1	0.80	0.666	1.07	A	EL	39.0		
	HL-93 (OPERATING)	N/A		1.42	--	1.35	0.666	1.42	A	EL	39.0	0.913	2.19	A	I	31.1	N/A	--	--	--	--	--		
	HS-20 (INVENTORY)	36.000	②	1.42	51.12	1.75	0.666	1.45	A	EL	39.0	0.913	1.85	A	I	31.1	0.80	0.666	1.42	A	EL	39.0		
	HS-20 (OPERATING)	36.000		1.88	67.68	1.35	0.666	1.88	A	EL	39.0	0.913	3.12	A	I	15.2	N/A	--	--	--	--	--		
LEGAL LOAD RATING	SINGLE VEHICLE (SV)	SNSH	13.500		3.26	44.01	1.40	0.666	4.14	A	EL	39.0	0.913	7.32	A	I	15.2	0.80	0.666	3.26	A	EL	39.0	
		SNGARBS2	20.000		2.41	48.20	1.40	0.666	3.06	A	EL	39.0	0.913	5.17	A	I	15.2	0.80	0.666	2.41	A	EL	39.0	
		SNAGRIS2	22.000		2.27	49.94	1.40	0.666	2.89	A	EL	39.0	0.913	4.79	A	I	15.2	0.80	0.666	2.27	A	EL	39.0	
		SNCOTTS3	27.250		1.62	44.15	1.40	0.666	2.06	A	EL	39.0	0.913	3.58	A	I	15.2	0.80	0.666	1.62	A	EL	39.0	
		SNAGGRS4	34.925		1.35	47.15	1.40	0.666	1.71	A	EL	39.0	0.913	2.75	A	I	31.1	0.80	0.666	1.35	A	EL	39.0	
		SNS5A	35.550		1.32	46.93	1.40	0.666	1.68	A	EL	39.0	0.913	2.90	A	I	31.1	0.80	0.666	1.32	A	EL	39.0	
		SNS6A	39.950		1.21	48.34	1.40	0.666	1.53	A	EL	39.0	0.913	2.45	A	I	31.1	0.80	0.666	1.21	A	EL	39.0	
	SNS7B	42.000		1.15	48.30	1.40	0.666	1.46	A	EL	39.0	0.913	2.45	A	I	31.1	0.80	0.666	1.15	A	EL	39.0		
	TRUCK TRACTOR SEMI-TRAILER (TTST)	TNAGRIT3	33.000		1.47	48.51	1.40	0.666	1.87	A	EL	39.0	0.913	3.27	A	I	15.2	0.80	0.666	1.47	A	EL	39.0	
		TNT4A	33.075		1.48	49.00	1.40	0.666	1.88	A	EL	39.0	0.913	3.18	A	I	15.2	0.80	0.666	1.48	A	EL	39.0	
		TNT6A	41.600		1.20	49.92	1.40	0.666	1.53	A	EL	39.0	0.913	2.87	A	I	15.2	0.80	0.666	1.20	A	EL	39.0	
		TNT7A	42.000		1.21	50.82	1.40	0.666	1.54	A	EL	39.0	0.913	2.55	A	I	31.1	0.80	0.666	1.21	A	EL	39.0	
		TNT7B	42.000		1.25	52.5	1.40	0.666	1.58	A	EL	39.0	0.913	2.27	A	I	31.1	0.80	0.666	1.25	A	EL	39.0	
		TNAGRIT4	43.000		1.19	51.17	1.40	0.666	1.51	A	EL	39.0	0.913	2.10	A	I	31.1	0.80	0.666	1.19	A	EL	39.0	
TNAGT5A		45.000		1.12	50.40	1.40	0.666	1.39	A	EL	39.0	0.913	2.16	A	I	31.1	0.80	0.666	1.12	A	EL	39.0		
TNAGT5B	45.000	③	1.11	49.95	1.40	0.666	1.41	A	EL	39.0	0.913	1.88	A	I	31.1	0.80	0.666	1.11	A	EL	39.0			

NOTES:
 MINIMUM RATING FACTORS ARE BASED ON THE STRENGTH I AND SERVICE III LIMIT STATES.
 ALLOWABLE STRESSES FOR SERVICE III LIMIT STATE ARE AS REQUIRED FOR DESIGN.

COMMENTS:
 1.
 2.
 3.
 4.

CONTROLLING LOAD RATING

① DESIGN LOAD RATING (HL-93)

② DESIGN LOAD RATING (HS-20)

③ LEGAL LOAD RATING **

** SEE CHART FOR VEHICLE TYPE

GIRDER LOCATION

I - INTERIOR GIRDER
 EL - EXTERIOR LEFT GIRDER
 ER - EXTERIOR RIGHT GIRDER

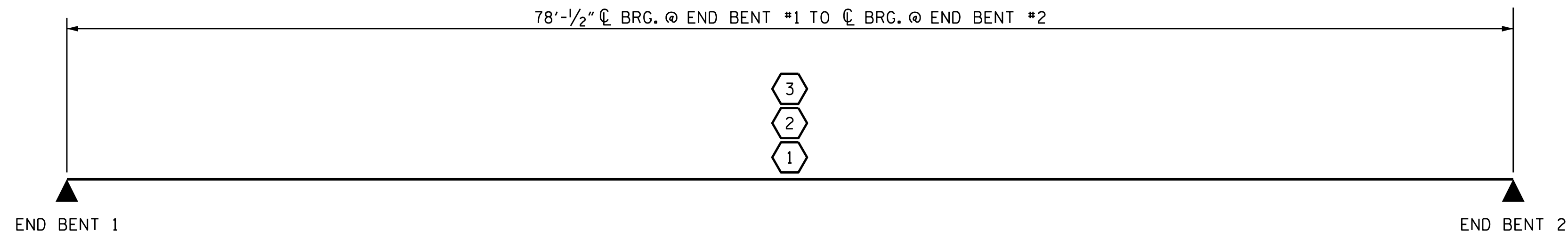

PROJECT NO. U-4405
CUMBERLAND COUNTY
 STATION: 26+78.00 -RPB-

LRFR SUMMARY

KCA 4800 SIX FORKS ROAD SUITE 120
 RALEIGH, NC 27609
 (919) 882-7839

ASSEMBLED BY : S. BOYD DATE : 05-17
 CHECKED BY : L. MARTINEZ DATE : 05-17

DRAWN BY : MAA 1/08 REV. 11/2/08RR MAA/GM
 CHECKED BY : GM/DI 2/08 REV. 10/17/11 MAA/GM

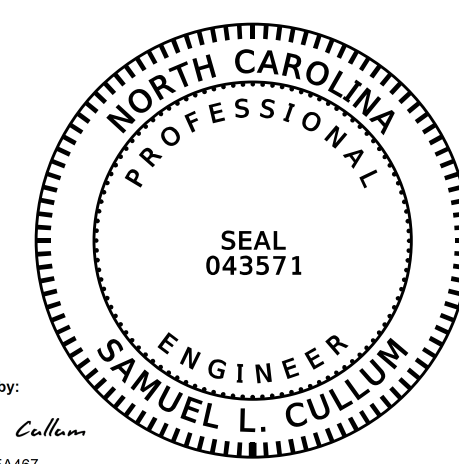

DocuSigned by:
 Samuel L. Cullum
 19C97095C75A467

6/6/2018 12:30:46 PM PDT

DOCUMENT NOT CONSIDERED
 FINAL UNLESS ALL
 SIGNATURES COMPLETED

STATE OF NORTH CAROLINA
 DEPARTMENT OF TRANSPORTATION
 RALEIGH

STANDARD
 LRFR SUMMARY FOR
 PRESTRESSED
 CONCRETE GIRDERS
 (NON-INTERSTATE TRAFFIC)

REVISIONS						SHEET NO. S-4
NO.	BY:	DATE:	NO.	BY:	DATE:	
1			3			TOTAL SHEETS 26
2			4			

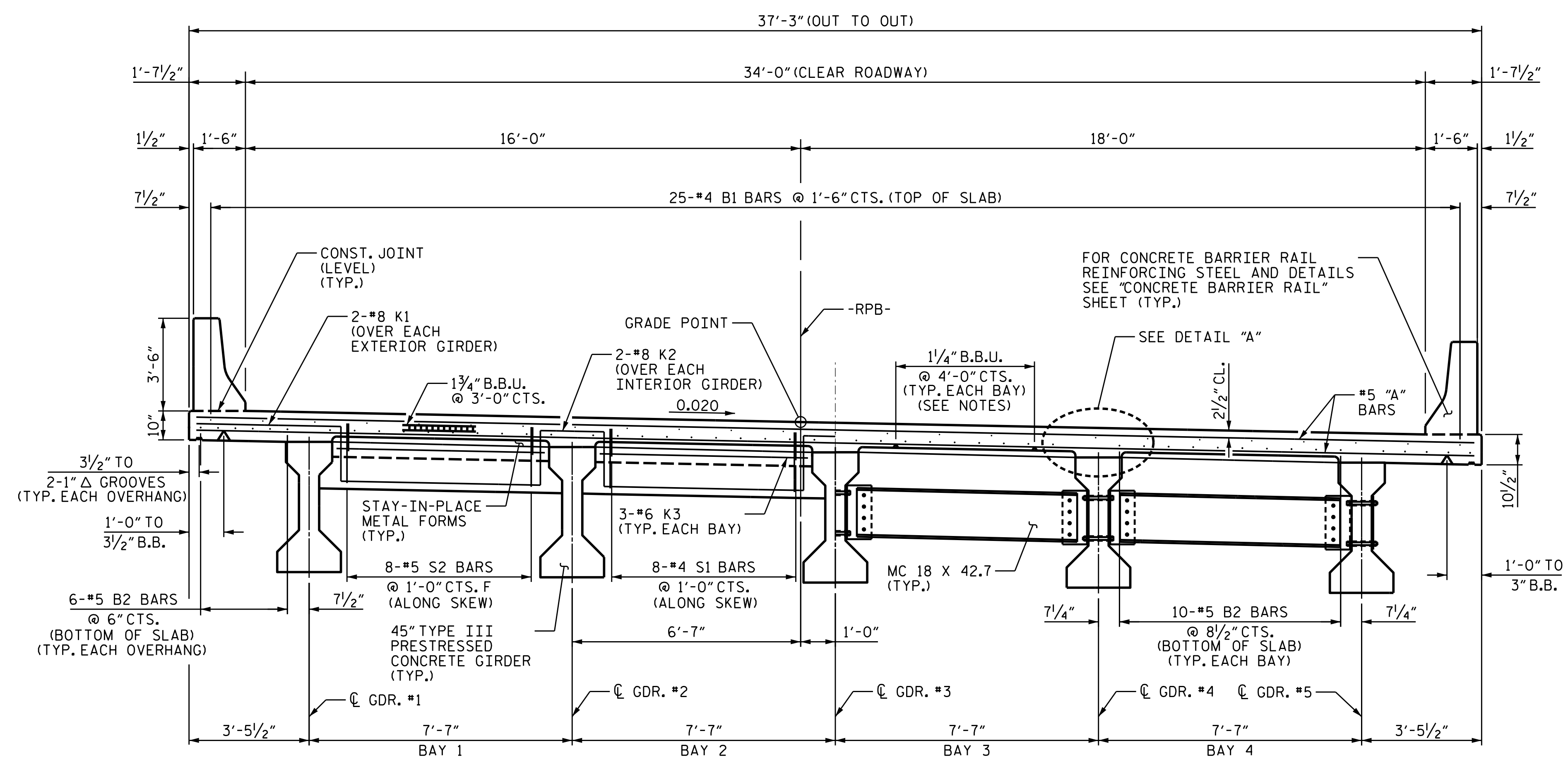

PARTIAL TYPICAL SECTION @ END BENT DIAPHRAGMS

PARTIAL TYPICAL SECTION @ INTERMEDIATE DIAPHRAGMS

(SEE "INTERMEDIATE STEEL DIAPHRAGMS FOR TYPE III PRESTRESSED CONCRETE GIRDERS" SHEET FOR DETAILS)

NOTES

- PROVIDE 1/4" HIGH BEAM BOLSTERS UPPER AT 4'-0" CTS. ATOP THE METAL STAY-IN-PLACE FORMS TO SUPPORT THE BOTTOM MAT OF 'A' BARS. WHEN USING REMOVABLE FORMS, PROVIDE CONTINUOUS HIGH CHAIRS FOR METAL DECK (C.H.C.M.) AT 4'-0" CTS. WITH A HEIGHT TO SUPPORT THE BOTTOM MAT OF 'A' BARS A CLEAR DISTANCE OF 2 1/2" ABOVE THE TOP OF THE REMOVABLE FORM.
- LONGITUDINAL STEEL MAY BE SHIFTED SLIGHTLY, AS NECESSARY, TO AVOID INTERFERENCE WITH STIRRUPS IN PRESTRESSED CONCRETE GIRDERS.
- #5 GI BAR MAY BE SHIFTED SLIGHTLY, AS NECESSARY, TO CLEAR REINFORCING STEEL AND STIRRUPS.
- BARRIER RAIL IN THE SPAN SHALL NOT BE CAST UNTIL ALL SLAB CONCRETE IN THE SPAN HAS BEEN CAST AND HAS REACHED A MINIMUM COMPRESSIVE STRENGTH OF 3,000 PSI.
- LONGITUDINAL STEEL MAY BE SHIFTED AS NECESSARY TO AVOID INTERFERENCE WITH STIRRUPS IN PRESTRESSED CONCRETE GIRDERS.
- ALL BAR SUPPORTS USED IN THE (BARRIER RAIL, PARAPET, DECK, APPROACH SLAB AND END BENT DIAPHRAGMS) AND ALL INCIDENTAL REINFORCING STEEL SHALL BE EPOXY COATED IN ACCORDANCE WITH THE STANDARD SPECIFICATIONS.

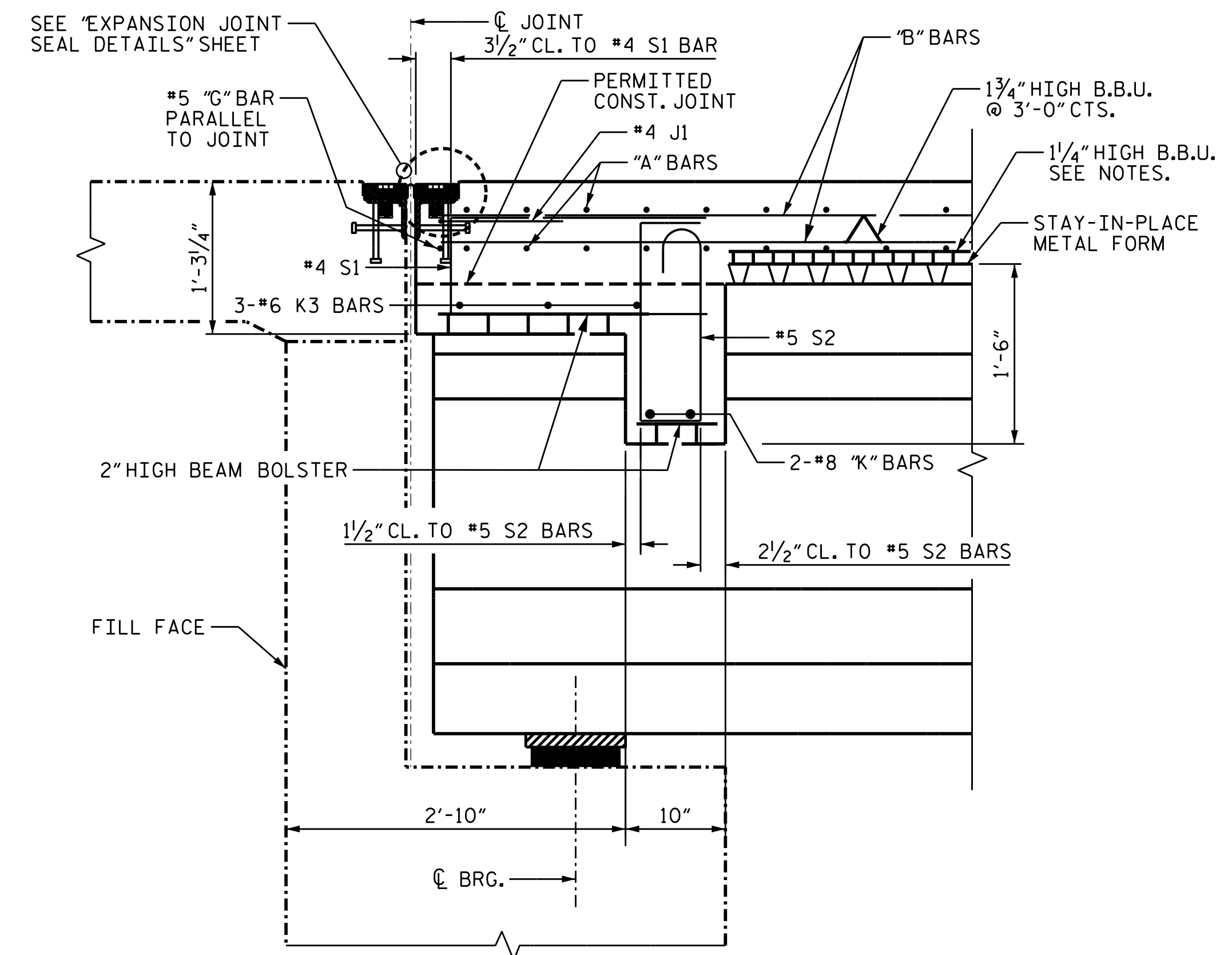

SECTION THRU END BENT DIAPHRAGMS

END BENT #1 SHOWN, END BENT #2 SIMILAR.

PROJECT NO. U-4405
CUMBERLAND COUNTY
 STATION: 26+78.00 -RPB-

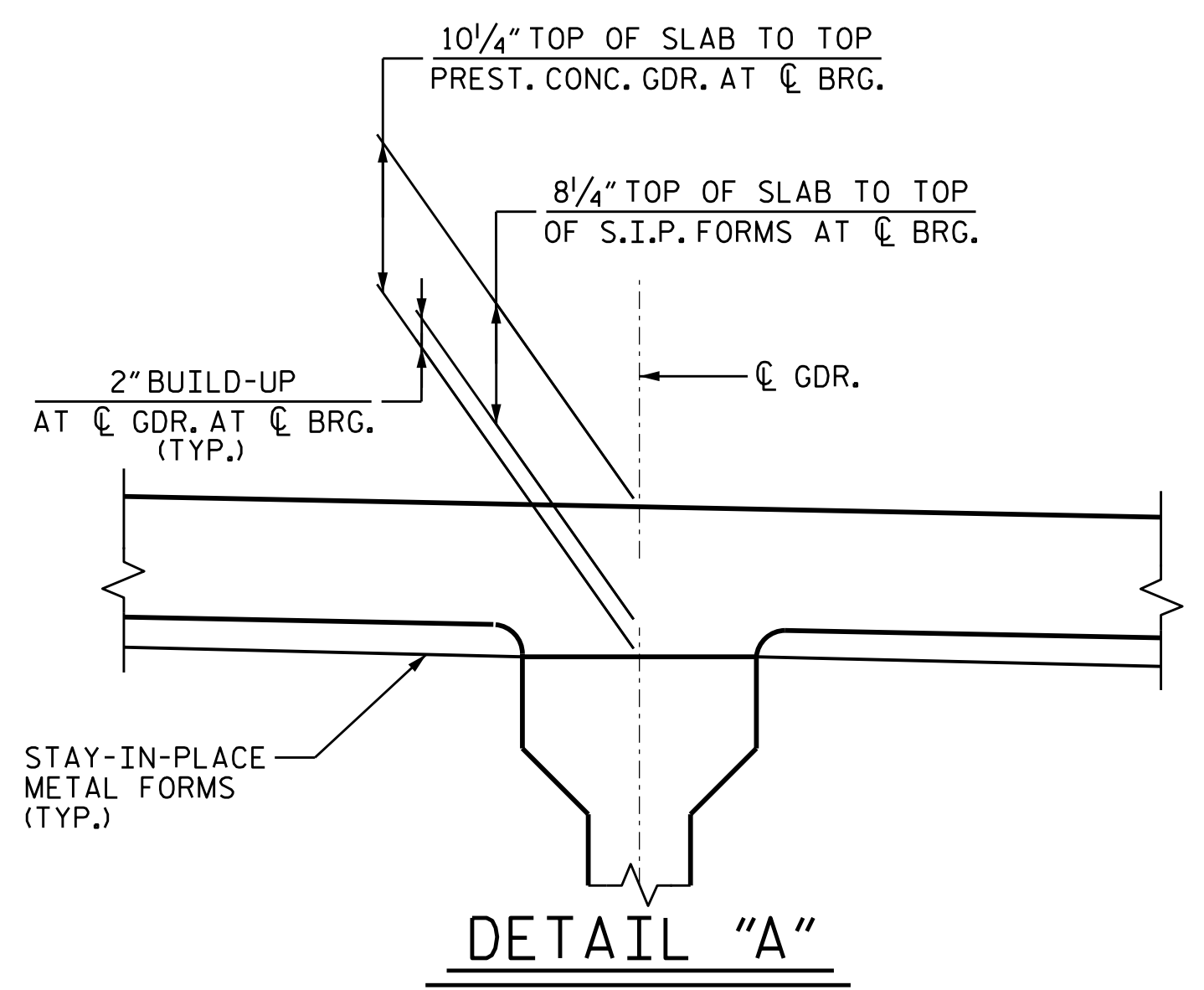

DETAIL "A"

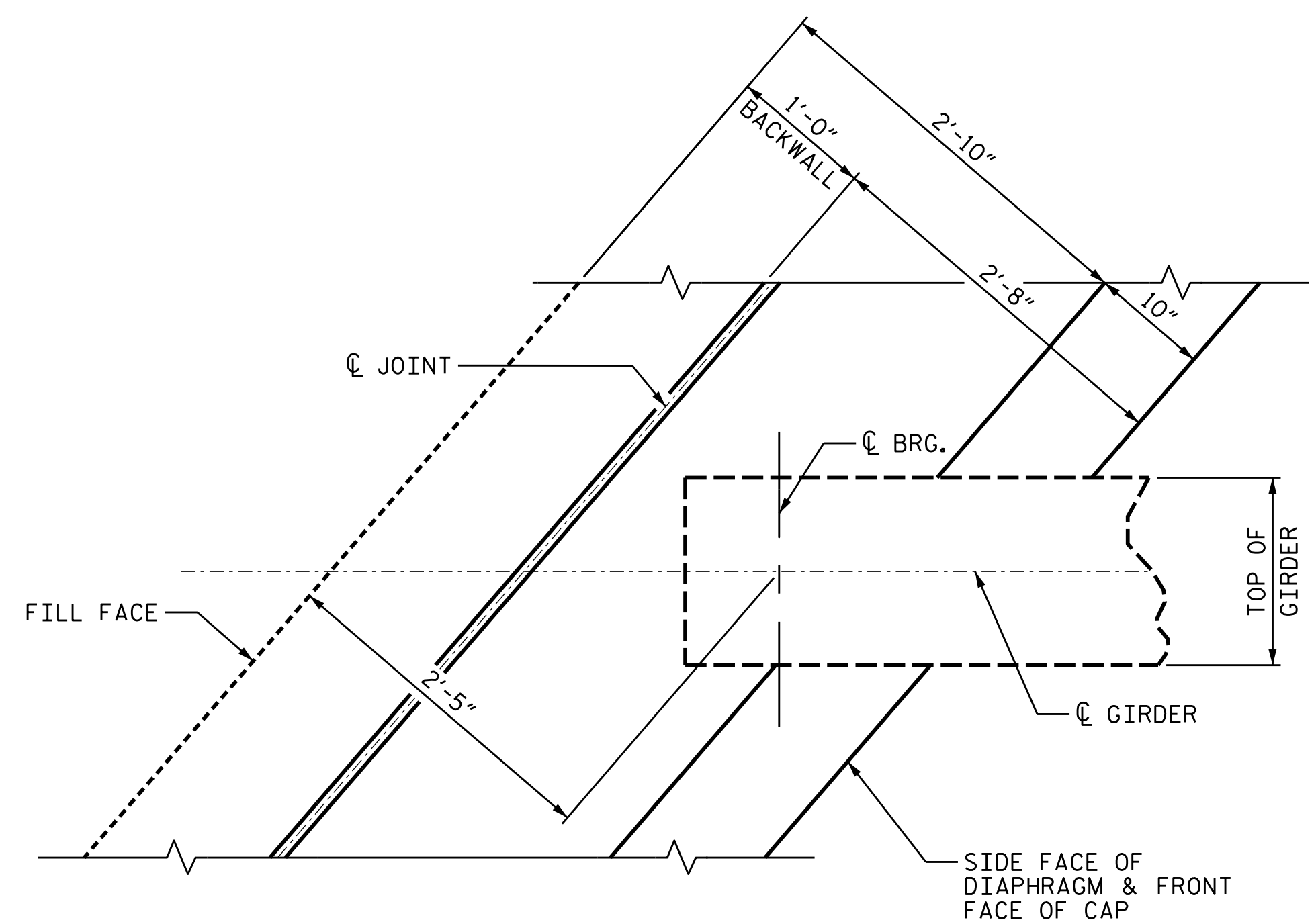

END BENT DIAPHRAGM PLAN

KCA 4800 SIX FORKS ROAD SUITE 120
 KISINGER CAMPO & ASSOCIATES RALEIGH, NC 27609
 (919) 882-7839

DRAWN BY : S. BOYD DATE : 5-17
 CHECKED BY : L. MARTINEZ DATE : 5-17
 DESIGN ENGINEER OF RECORD: S. CULLUM DATE : 5-17

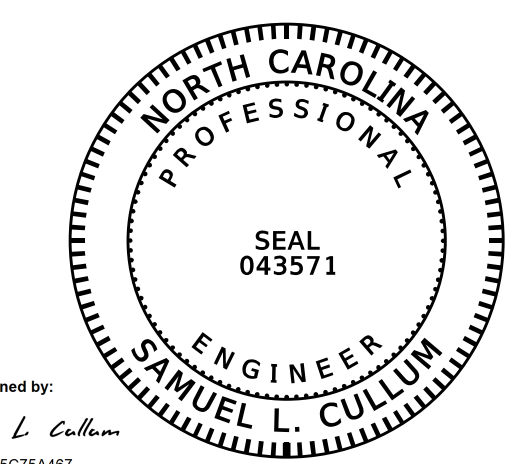

6/6/2018 12:30:46 PM PDT

DOCUMENT NOT CONSIDERED FINAL UNLESS ALL SIGNATURES COMPLETED

STATE OF NORTH CAROLINA DEPARTMENT OF TRANSPORTATION RALEIGH						SHEET NO.	
SUPERSTRUCTURE TYPICAL SECTION & DETAILS						S-5	
REVISIONS						TOTAL SHEETS	
NO.	BY:	DATE:	NO.	BY:	DATE:	26	
1			3				
2			4				

NOTES

FOR PLACEMENT OF #4 JI BARS, SEE "EXPANSION JOINT SEAL DETAIL" SHEET.

FOR BARRIER RAIL DETAILS AND REINFORCING STEEL, SEE "CONCRETE BARRIER RAIL" SHEET.

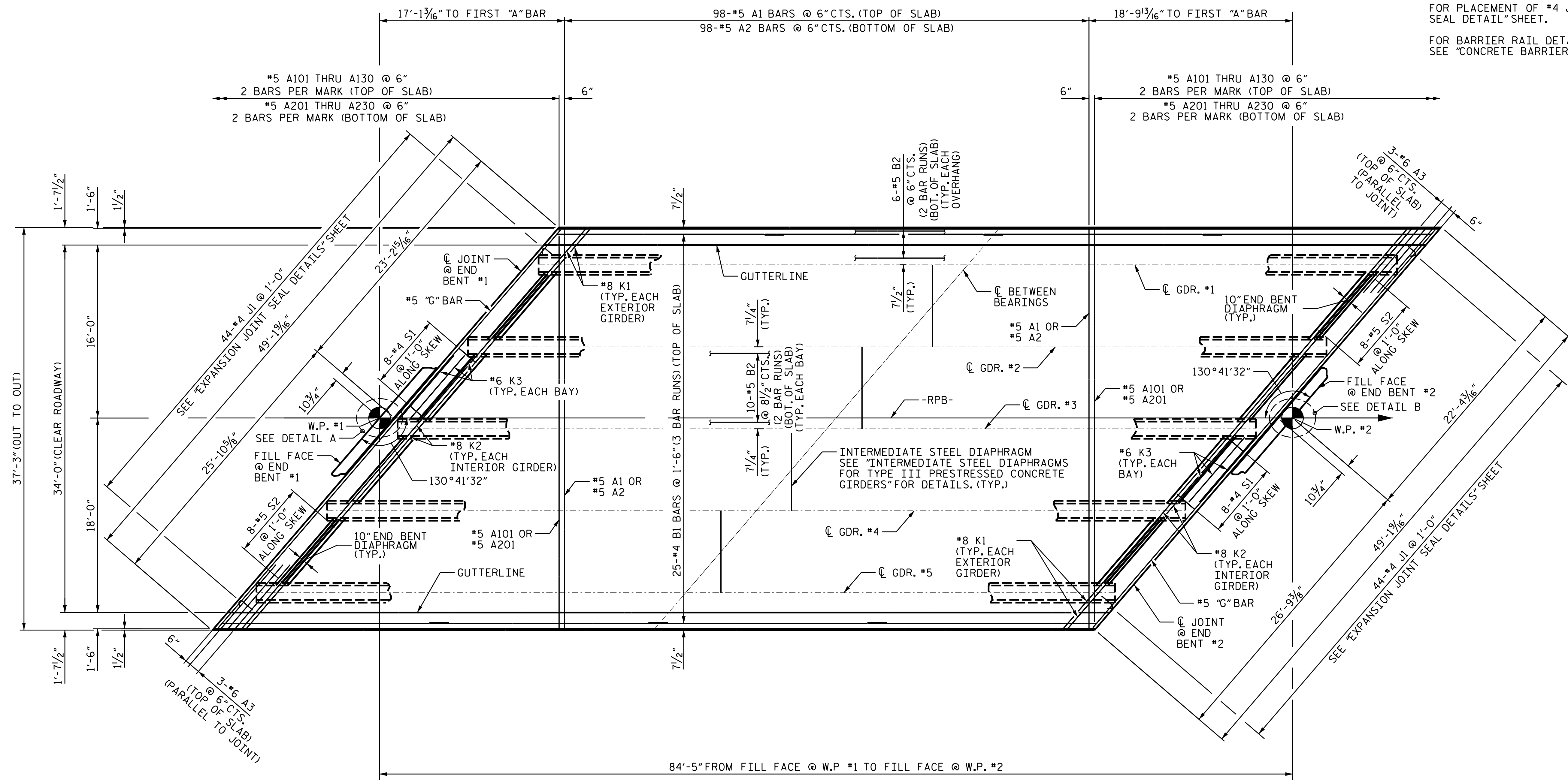

PLAN OF SPAN

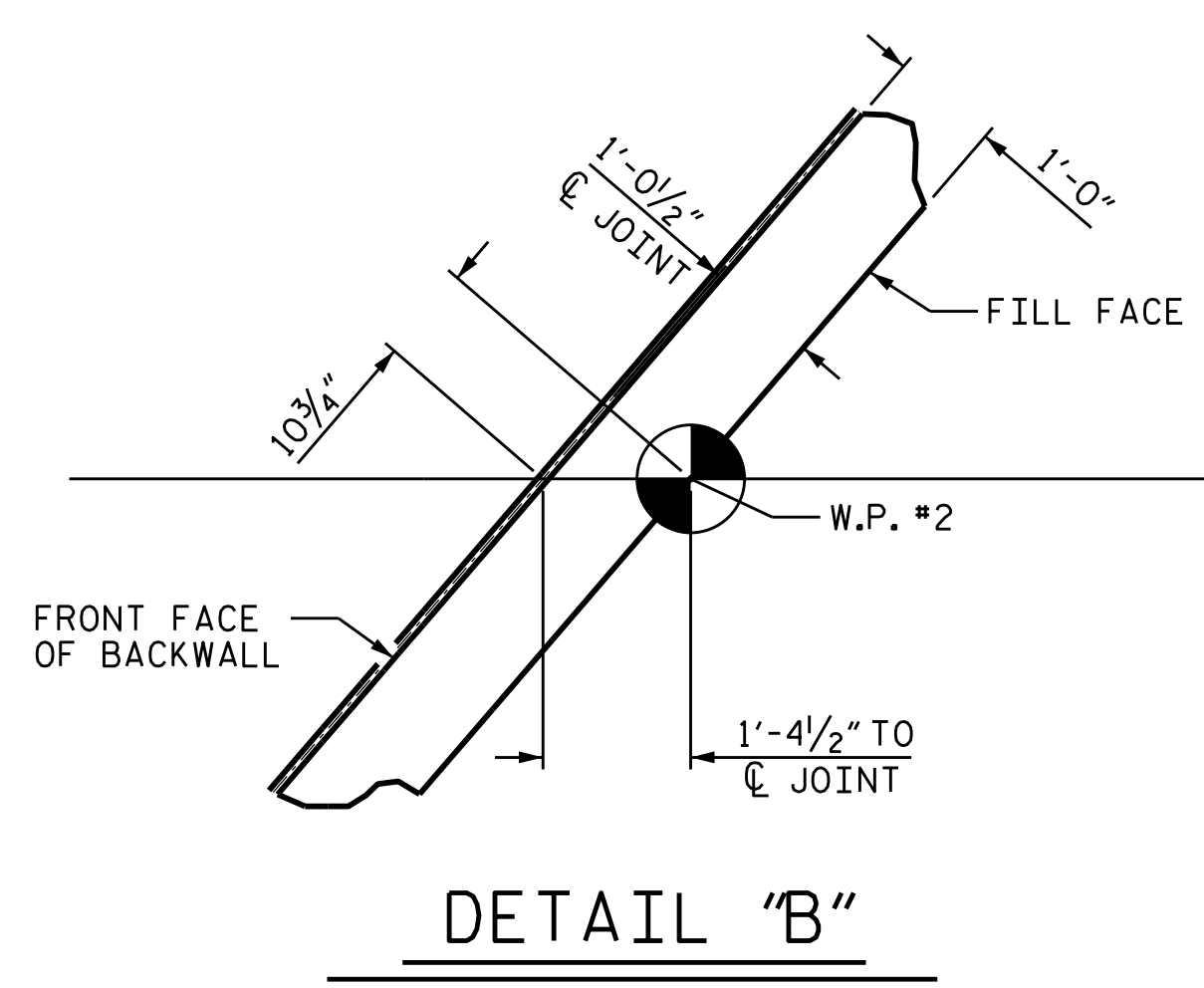
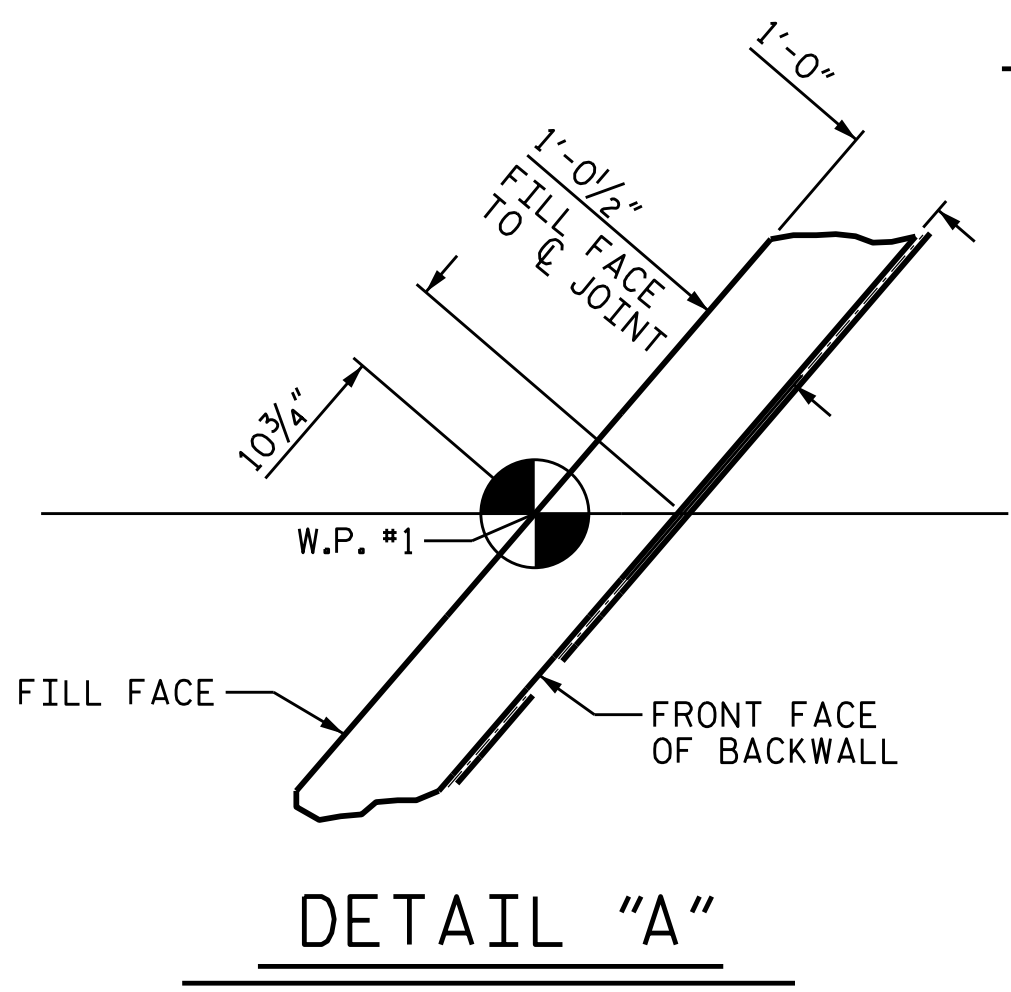

PROJECT NO. U-4405
CUMBERLAND COUNTY
 STATION: 26+78.00 -RPB-

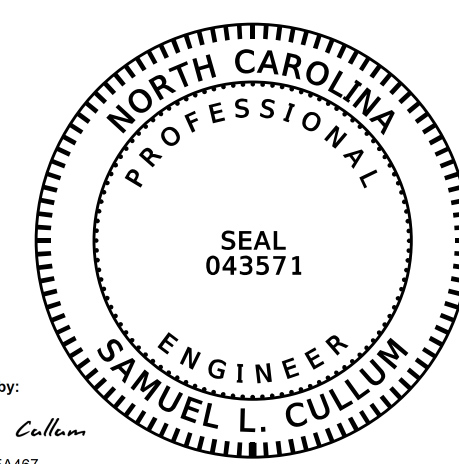

STATE OF NORTH CAROLINA
 DEPARTMENT OF TRANSPORTATION
 RALEIGH
 SUPERSTRUCTURE
 PLAN OF SPAN

KCA 4800 SIX FORKS ROAD SUITE 120
 KISINGER CAMPO & ASSOCIATES RALEIGH, NC 27609
 (919) 882-7839

DRAWN BY: J. B. HANNA DATE: 05-17
 CHECKED BY: S. BOYD DATE: 05-17
 DESIGN ENGINEER OF RECORD: S. CULLUM DATE: 05-17

REVISIONS						SHEET NO.
NO.	BY:	DATE:	NO.	BY:	DATE:	S-6
1			3			TOTAL SHEETS
2			4			26

DOCUMENT NOT CONSIDERED FINAL UNLESS ALL SIGNATURES COMPLETED

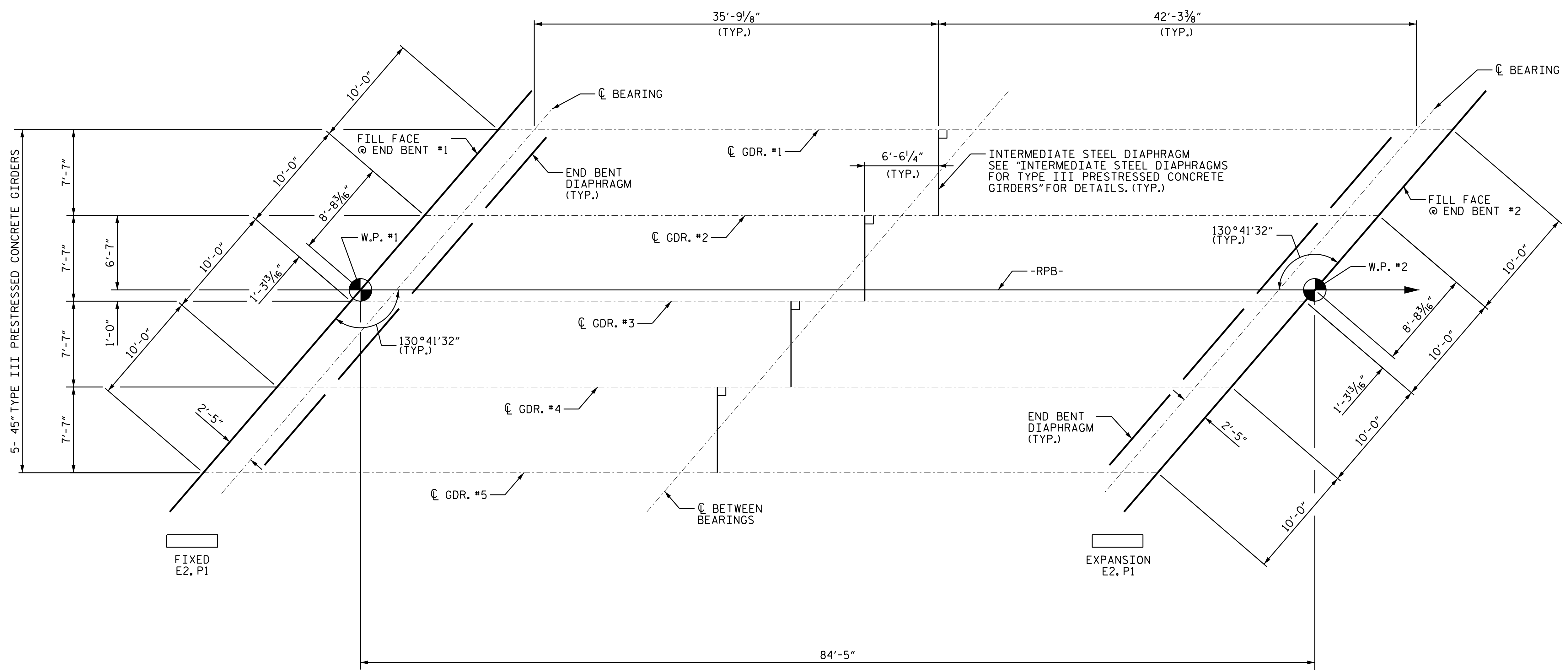

GIRDER LAYOUT (SPAN "A")

FOR LOCATION OF INTERMEDIATE DIAPHRAGMS, SEE GIRDER DIMENSIONS ON "AASHTO TYPE III PRESTRESSED CONCRETE GIRDER" SHEET.

PROJECT NO. U-4405
CUMBERLAND COUNTY
 STATION: 26+78.00 -RPB-

KCA 4800 SIX FORKS ROAD SUITE 120
 KISINGER CAMPO & ASSOCIATES RALEIGH, NC 27609
 (919) 882-7839

DRAWN BY : J. B. HANNA DATE : 05-17
 CHECKED BY : L. MARTINEZ DATE : 05-17
 DESIGN ENGINEER OF RECORD: S. CULLUM DATE : 05-17

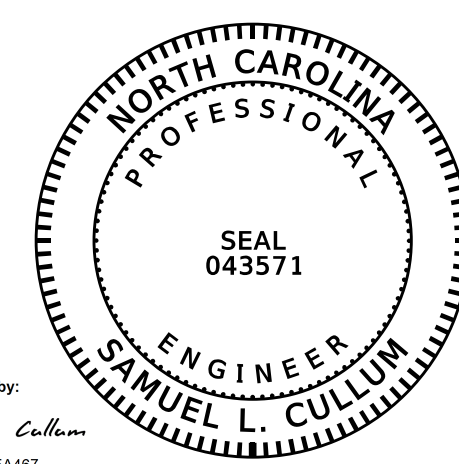

DocuSigned by:
 Samuel L. Cullum
 19C97095C75A467

6/6/2018 12:30:46 PM PDT

DOCUMENT NOT CONSIDERED
 FINAL UNLESS ALL
 SIGNATURES COMPLETED

STATE OF NORTH CAROLINA
 DEPARTMENT OF TRANSPORTATION
 RALEIGH
 SUPERSTRUCTURE
 GIRDER LAYOUT
 SPAN "A"

REVISIONS						SHEET NO.
NO.	BY:	DATE:	NO.	BY:	DATE:	S-7
1			3			TOTAL SHEETS
2			4			26

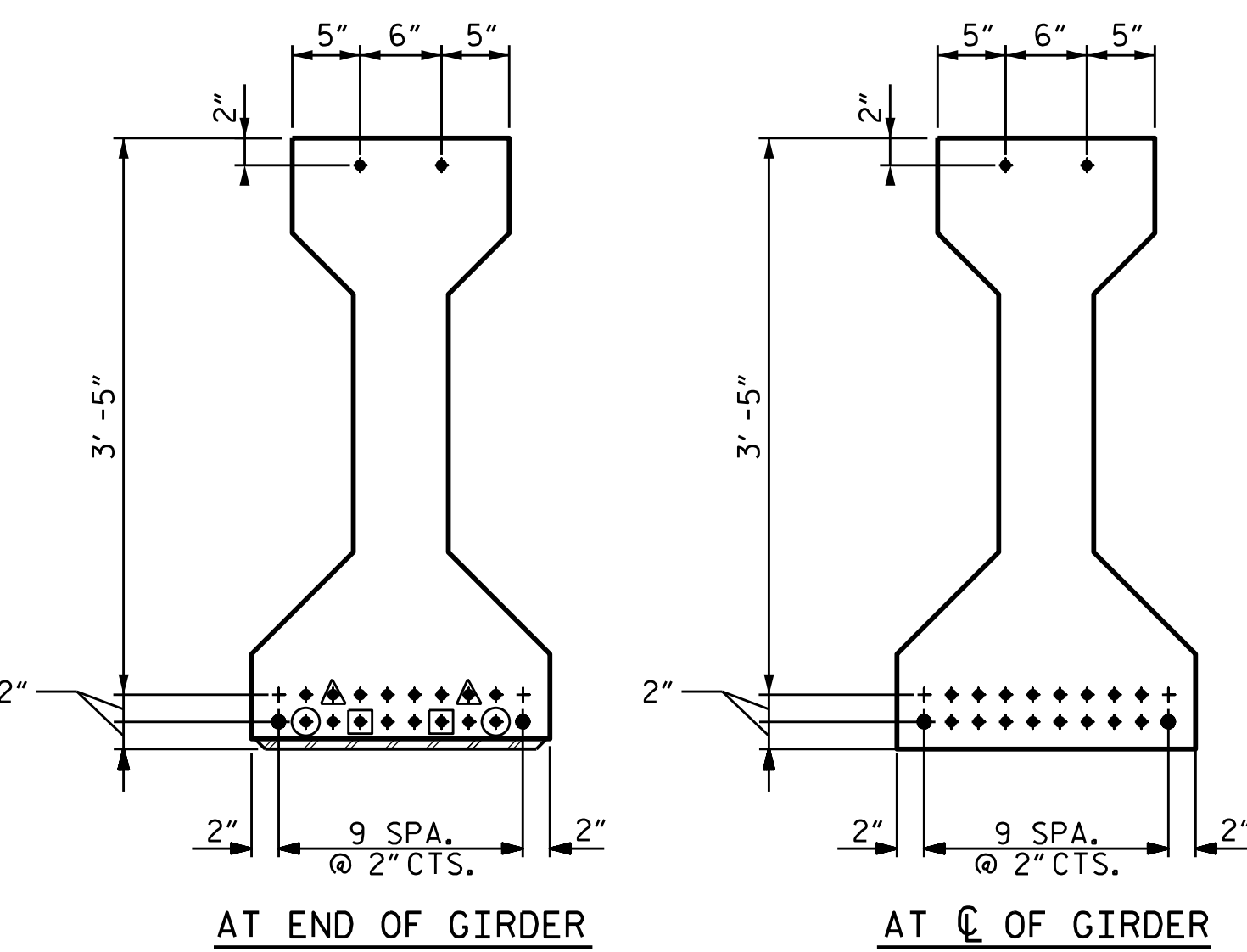
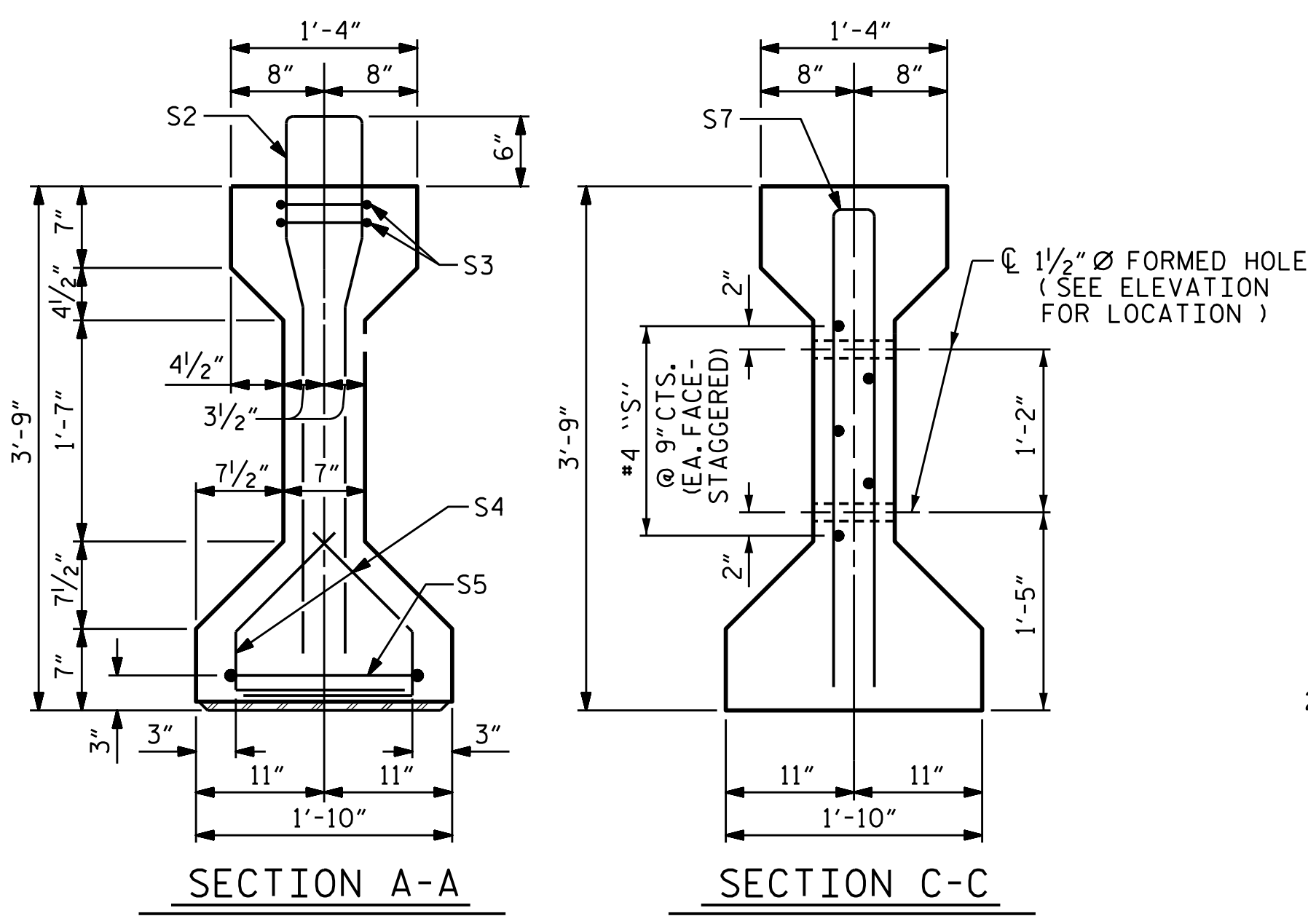

0.6" Ø LOW RELAXATION STRAND LAYOUT (20 STRANDS)

- DEBONDING LEGEND**
- FULLY BONDED STRANDS
 - STRANDS DEBONDED FOR 4'-0" FROM END OF GIRDER
 - ▲ STRANDS DEBONDED FOR 6'-0" FROM END OF GIRDER
 - STRANDS DEBONDED FOR 8'-0" FROM END OF GIRDER

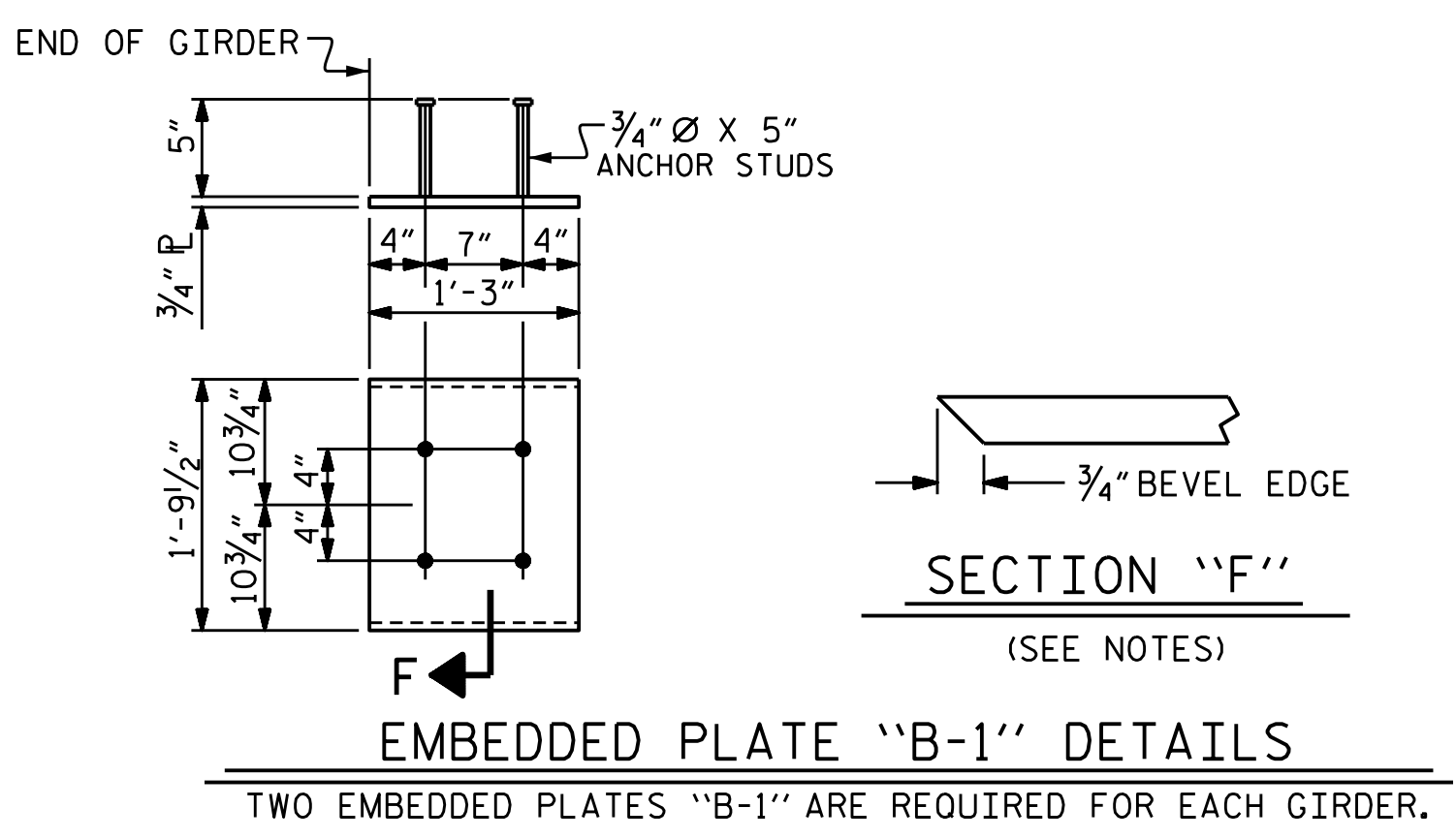

NOTES

ALL PRESTRESSING STRANDS SHALL BE 7-WIRE LOW-RELAXATION GRADE 270 STRANDS AND SHALL CONFORM TO AASHTO M203 EXCEPT FOR SAMPLING REQUIREMENTS WHICH SHALL BE IN ACCORDANCE WITH THE STANDARD SPECIFICATIONS.

APPLY EPOXY PROTECTIVE COATING TO END OF GIRDER SURFACES.

EMBEDDED PLATE "B-1" SHALL BE GALVANIZED IN ACCORDANCE WITH THE STANDARD SPECIFICATIONS.

ANCHOR STUDS SHALL CONFORM TO AASHTO M169 GRADES 1010 THROUGH 1020 OR APPROVED EQUAL, AND SHALL MEET THE TYPE "B" REQUIREMENTS OF SUBSECTION 7.3 OF THE ANSI/AASHTO/AWS D1.5 BRIDGE WELDING CODE.

ALL PRESTRESSED STRANDS SHALL BE CUT FLUSH WITH THE GIRDER ENDS.

THE TRANSFER OF LOAD FROM THE ANCHORAGES TO THE GIRDER SHALL BE DONE WHEN CONCRETE HAS REACHED A COMPRESSIVE STRENGTH OF NOT LESS THAN 8,000 PSI.

DEPENDING ON THE TYPE OF SYSTEM USED TO SUPPORT THE DECK SLAB FORMS, PRESET ANCHORS MAY BE NECESSARY IN THE PRESTRESSED CONCRETE GIRDER.

THE TOP SURFACE OF THE GIRDER SHALL BE RAKED TO A DEPTH OF 1/4" EXCEPT IN THE AREA BETWEEN THE STIRRUP AND THE EDGE OF THE GIRDER.

WHEN DRAPED STRANDS ARE DETAILED, THE LONGITUDINAL LOCATION OF THE HOLD DOWN DEVICES SHALL BE WITHIN 6" OF THE LOCATION SHOWN AND THE CENTER OF GRAVITY OF THE GROUP OF DRAPED STRANDS SHALL BE LOCATED WITHIN 1/2" OF THE THEORETICAL LOCATION SHOWN.

FOR PRESTRESSED CONCRETE GIRDERS, SEE SPECIAL PROVISIONS.

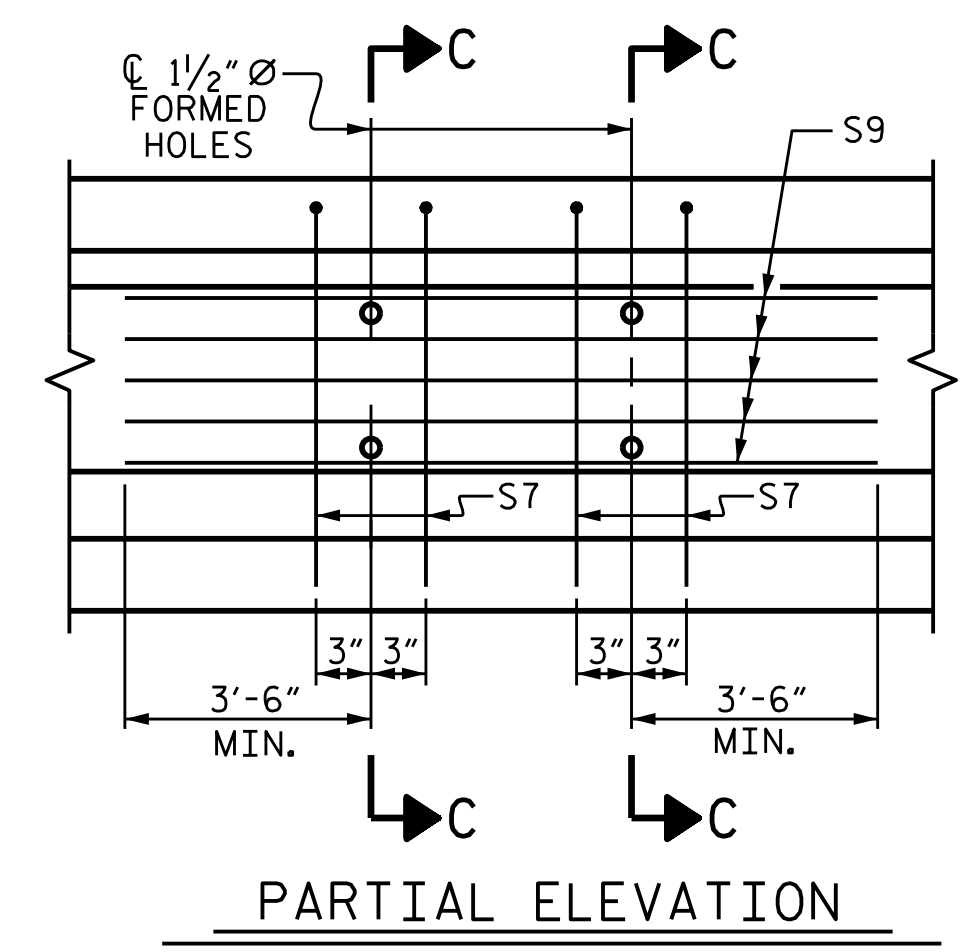

SHOWING INTERMEDIATE DIAPHRAGM REINFORCING STEEL FOR GIRDER Nos. 2 THRU 4

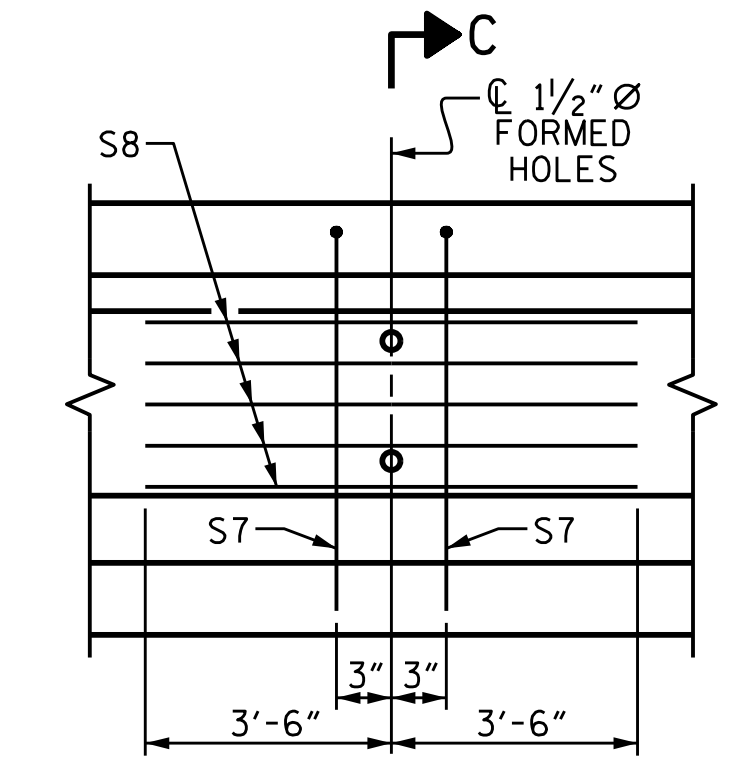

SHOWING INTERMEDIATE DIAPHRAGM REINFORCING STEEL FOR GIRDER Nos. 1 AND 5

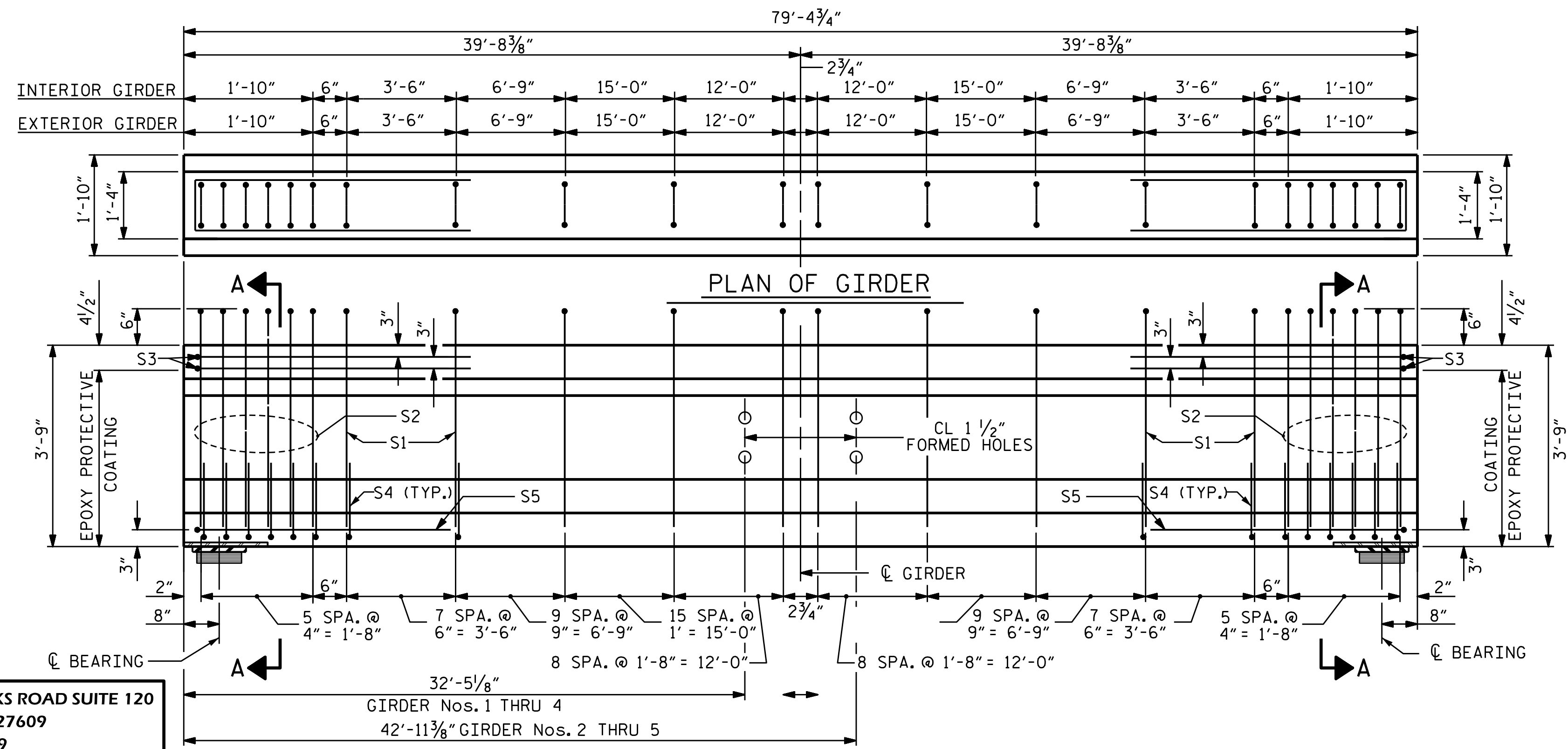

ELEVATION OF GIRDER
 (SEE PARTIAL ELEVATION FOR ADDITIONAL "S" BARS)

0.6" Ø L. R. GRADE 270 STRANDS		
AREA (SQ. INCHES)	ULTIMATE STRENGTH (LBS. PER STRAND)	APPLIED PRESTRESS (LBS. PER STRAND)
0.217	58,600	43,950

REINFORCING STEEL FOR ONE GIRDER						
BAR	NUMBER	SIZE	TYPE	LENGTH	WEIGHT	
S1	80	#4	1	8'-6"	454	EXTERIOR GDR.
S1	80	#4	1	8'-6"	454	INTERIOR GDR.
S2	12	#6	1	8'-6"	153	
S3	4	#4	3	8'-8"	23	
S4	56	#4	2	2'-9"	103	
S5	2	#4	3	9'-6"	13	
S7	2	#5	3	7'-2"	15	EXTERIOR GDR.
S7	4	#5	3	7'-2"	30	INTERIOR GDR.
S8	5	#4	STR	7'-0"	23	EXTERIOR GDR.
S9	5	#4	STR	13'-7"	45	INTERIOR GDR.

BAR TYPES

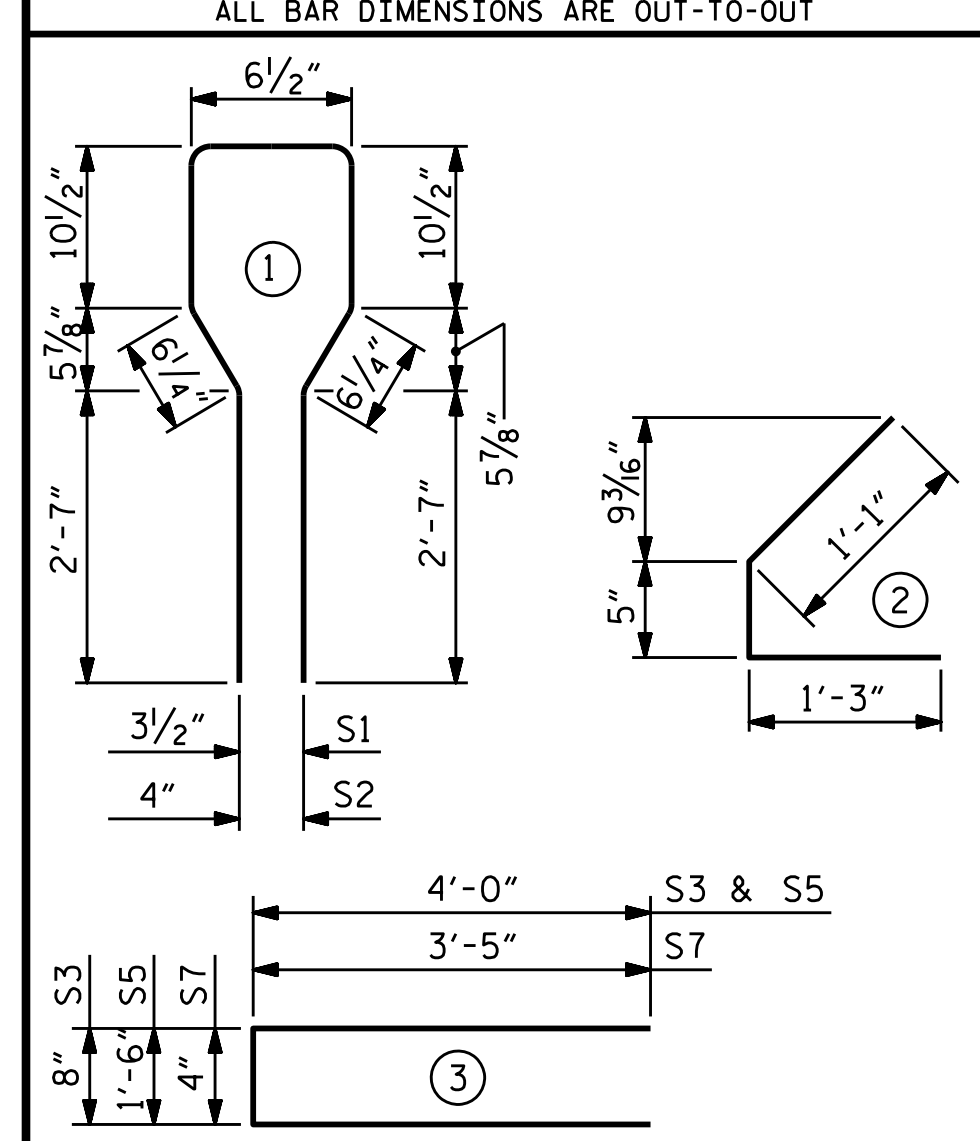

QUANTITIES FOR ONE GIRDER			
	REINFORCING STEEL (LB.)	10,000 PSI CONCRETE (C.Y.)	0.6" Ø L. R. STRANDS (No.)
EXTERIOR GIRDER	784	11.4	18
INTERIOR GIRDER	821	11.4	18

GIRDERS REQUIRED		
NUMBER	LENGTH	TOTAL LENGTH
1 THRU 5	79'-4 3/4"	396'-11 3/4"

PROJECT NO. U-4405
CUMBERLAND COUNTY
 STATION: 26+78.00 -RPB-

STATE OF NORTH CAROLINA
 DEPARTMENT OF TRANSPORTATION
 RALEIGH
 STANDARD
 AASHTO TYPE III
 PRESTRESSED CONCRETE GIRDER

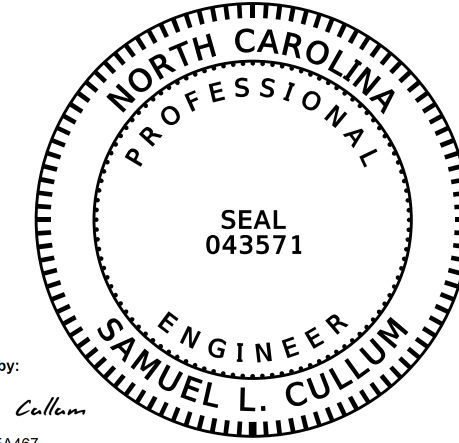

REVISIONS

NO.	BY:	DATE:	NO.	BY:	DATE:
1			3		
2			4		

DOCUMENT NOT CONSIDERED FINAL UNLESS ALL SIGNATURES COMPLETED

SHEET NO.	
S-8	26

KCA 4800 SIX FORKS ROAD SUITE 120
 RALEIGH, NC 27609
 (919) 882-7839

ASSEMBLED BY: J. B. HANNA DATE: 5/17
 CHECKED BY: L. MARTINEZ DATE: 5/17

DRAWN BY: JMB 12/87
 CHECKED BY: ARB 12/87

REV. 10/1/11 MAA/GM
 REV. 1/15 MAA/TMG
 REV. 2/15 MAA/TMG

DEAD LOAD DEFLECTION TABLE FOR GIRDERS

0.6" Ø LOW RELAXATION	SPAN A																																	
	GIRDER #1											GIRDER #2 THRU #4											GIRDER #5											
	TENTH POINTS	0	.1	.2	.3	.4	.5	.6	.7	.8	.9	0	0	.1	.2	.3	.4	.5	.6	.7	.8	.9	0	0	.1	.2	.3	.4	.5	.6	.7	.8	.9	0
CAMBER (GIRDER ALONE IN PLACE)	↑	0.000	0.050	0.095	0.130	0.152	0.160	0.152	0.130	0.095	0.050	0.000	0.000	0.050	0.095	0.130	0.152	0.160	0.152	0.130	0.095	0.050	0.000	0.000	0.050	0.095	0.130	0.152	0.160	0.152	0.130	0.095	0.050	0.000
* DEFLECTION DUE TO SUPERIMPOSED D.L.	↓	0.000	0.027	0.054	0.075	0.088	0.092	0.088	0.075	0.054	0.027	0.000	0.000	0.028	0.056	0.078	0.092	0.097	0.092	0.078	0.056	0.028	0.000	0.000	0.027	0.054	0.075	0.088	0.092	0.088	0.075	0.054	0.027	0.000
FINAL CAMBER	↑	0	1/4"	1/2"	11/16"	3/4"	13/16"	3/4"	11/16"	1/2"	1/4"	0	0	1/4"	7/16"	5/8"	3/4"	3/4"	3/4"	5/8"	7/16"	1/4"	0	0	1/4"	1/2"	11/16"	3/4"	13/16"	3/4"	11/16"	1/2"	1/4"	0

* INCLUDES FUTURE WEARING SURFACE
 ALL VALUES ARE SHOWN IN FEET (DECIMAL FORM), EXCEPT " FINAL CAMBER ", WHICH IS GIVEN IN INCHES (FRACTION FORM).

PROJECT NO. U-4405
CUMBERLAND COUNTY
 STATION: 26+78.00 -RPB-

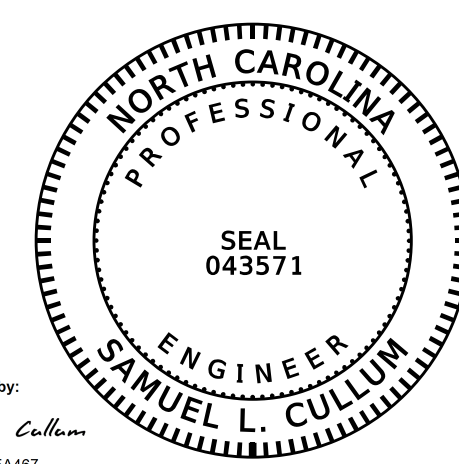

STATE OF NORTH CAROLINA
 DEPARTMENT OF TRANSPORTATION
 RALEIGH

**PRESTRESSED CONCRETE GIRDER
 DETAILS**

KCA 4800 SIX FORKS ROAD SUITE 120
 KISINGER CAMPO & ASSOCIATES RALEIGH, NC 27609
 (919) 882-7839

DRAWN BY : J. B. HANNA DATE : 05-17
 CHECKED BY : L. MARTINEZ DATE : 05-17
 DESIGN ENGINEER OF RECORD: S. CULLUM DATE : 05-17

DocuSigned by:
 Samuel L. Cullum
 19C97095C75A467...

6/6/2018 12:30:46 PM PDT

DOCUMENT NOT CONSIDERED
 FINAL UNLESS ALL
 SIGNATURES COMPLETED

REVISIONS						SHEET NO.
NO.	BY:	DATE:	NO.	BY:	DATE:	S-9
1			3			TOTAL SHEETS
2			4			26

STRUCTURAL STEEL NOTES

ALL INTERMEDIATE DIAPHRAGM STEEL AND CONNECTOR PLATES SHALL BE AASHTO M270 GRADE 50 OR APPROVED EQUAL.

TENSION ON THE ASTM A325 BOLTS THROUGH THE CHANNEL MEMBER SHALL BE CALIBRATED USING DIRECT TENSION INDICATOR WASHERS IN ACCORDANCE WITH THE STANDARD SPECIFICATIONS.

TENSION ON THE ASTM A449 BOLTS THROUGH THE GIRDER WEB SHALL BE SNUG TIGHTENED FOLLOWED BY AN ADDITIONAL 1/4 TURN.

THE PLATES, BENT PLATES, CHANNELS, AND ANGLES SHALL BE GALVANIZED OR METALLIZED IN ACCORDANCE WITH THE STANDARD SPECIFICATIONS. FOR THERMAL SPRAYED COATINGS (METALLIZATION), SEE SPECIAL PROVISIONS.

FOR METALLIZATION, APPLY A 10.0 - 15.0 MIL THICK 99.99 PERCENT ZINC (W-ZN-1) THERMAL SPRAYED COATING WITH A 1.5 MIL THICK SEAL COAT TO ALL STEEL DIAPHRAGM SURFACES METALLIZED IN ACCORDANCE WITH THE DEPARTMENT'S THERMAL SPRAYED COATINGS PROGRAM.

FOR THERMAL SPRAYED COATINGS, SEE SPECIAL PROVISIONS.

PRIOR TO BEGINNING METALLIZATION, THE CONTRACTOR WILL PROVIDE METALLIZED SAMPLES TO THE ENGINEER FOR APPROVAL.

GALVANIZE THE HIGH STRENGTH BOLTS, NUTS, WASHERS AND DIRECT TENSION INDICATORS IN ACCORDANCE WITH THE STANDARD SPECIFICATIONS.

USE AN ASTM F436 HARDENED WASHER WITH STANDARD AND SLOTTED HOLES UNDER EACH BOLT HEAD AND NUT.

FOR BOLTS THROUGH THE GIRDER WEB, PROVIDE SUFFICIENT LENGTH OF THREADS ON ALL BOLTS TO ACCOMMODATE WASHERS AND THE THICKNESS OF CONNECTING MEMBER PLUS AT LEAST 1/4" PROJECTION BEYOND THE NUT.

INTERMEDIATE DIAPHRAGM ASSEMBLY SHALL COMPLY WITH SECTION 1072 OF THE STANDARD SPECIFICATIONS.

SUBMIT TWO SETS OF WORKING DRAWINGS FOR THE INTERMEDIATE DIAPHRAGM ASSEMBLY FOR REVIEW, COMMENTS AND ACCEPTANCE. AFTER REVIEW, COMMENTS, AND ACCEPTANCE, SUBMIT SEVEN SETS FOR DISTRIBUTION.

IN THE EXTERIOR BAYS, PLACE TEMPORARY STRUTS BETWEEN PRESTRESSED GIRDERS ADJACENT TO THE STEEL DIAPHRAGMS. STRUTS SHALL REMAIN IN PLACE 3 DAYS AFTER CONCRETE IS PLACED.

THE COST OF THE STEEL DIAPHRAGMS AND ASSEMBLIES SHALL BE INCLUDED IN THE UNIT PRICE BID FOR PRESTRESSED CONCRETE GIRDERS.

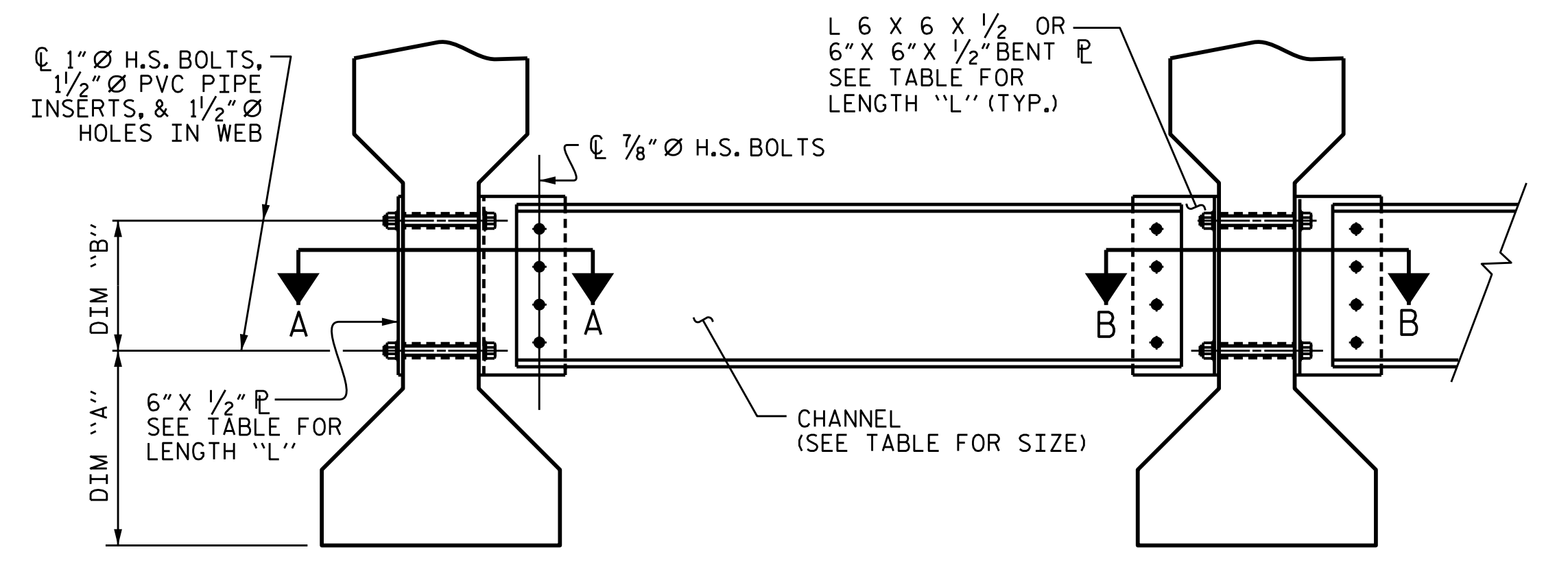

EXTERIOR GIRDER **INTERIOR GIRDER**
PART SECTION AT INTERMEDIATE DIAPHRAGM

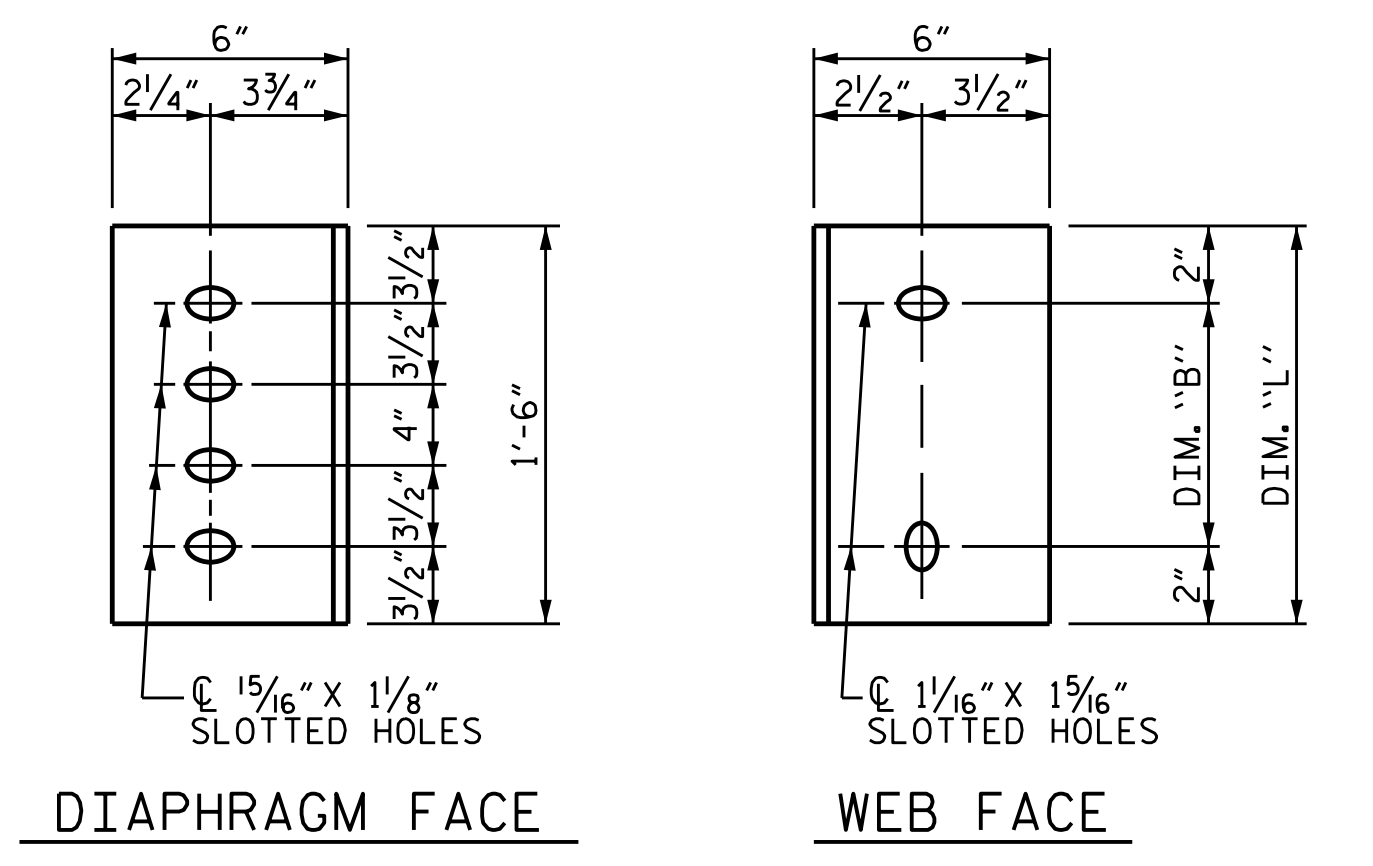

DIAPHRAGM FACE **WEB FACE**
CONNECTOR PLATE DETAILS

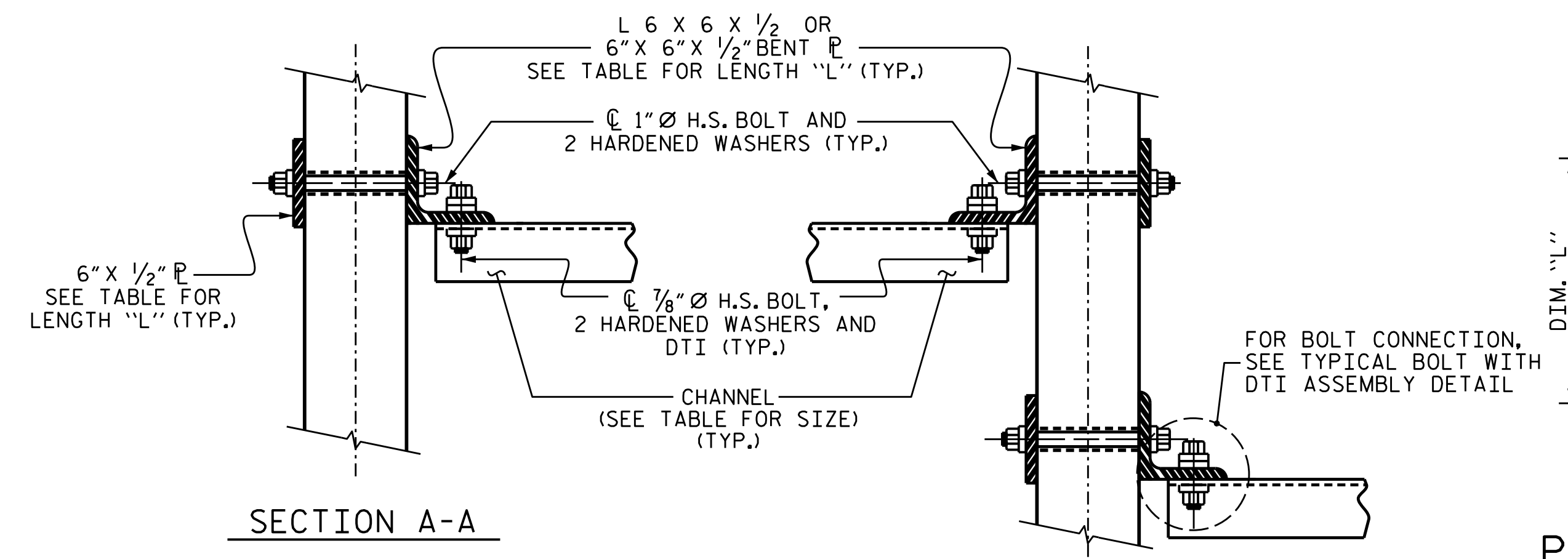

SECTION A-A **SECTION B-B**
CONNECTION DETAILS

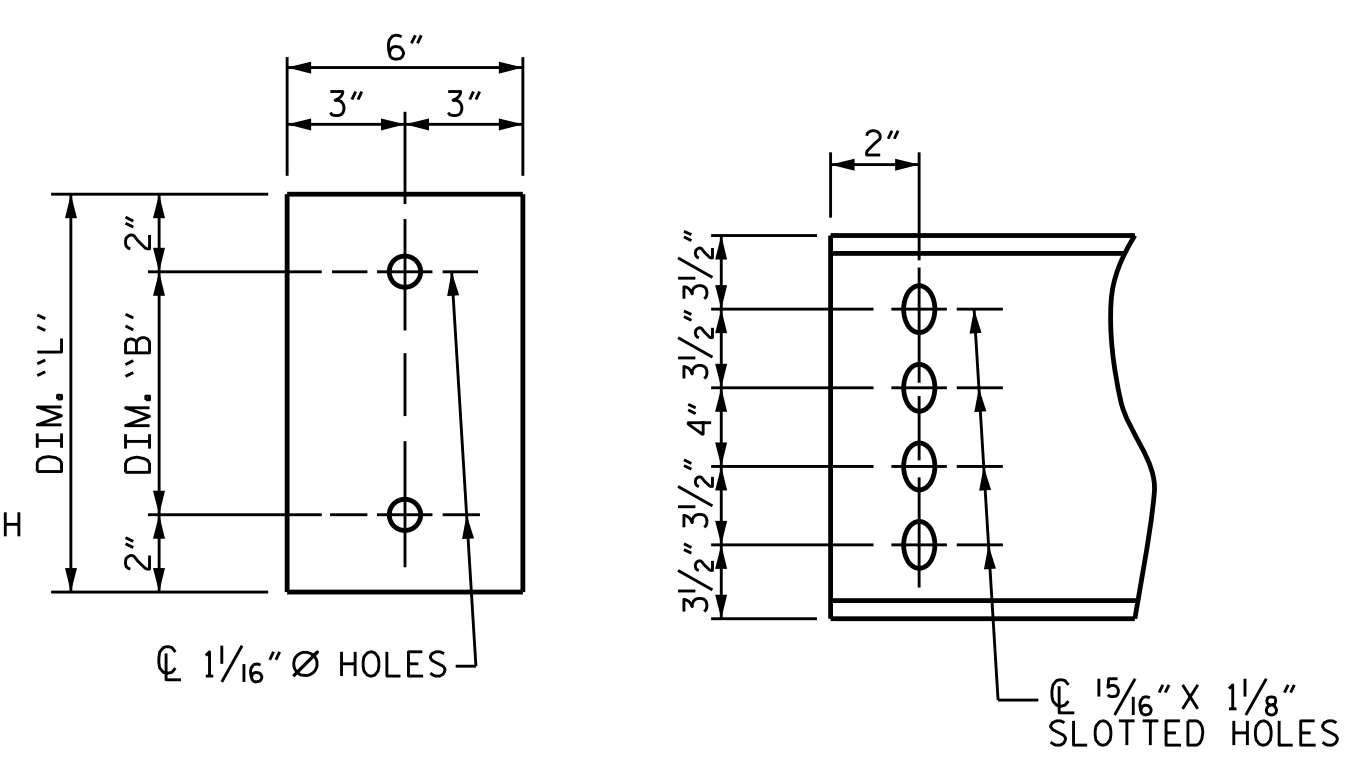
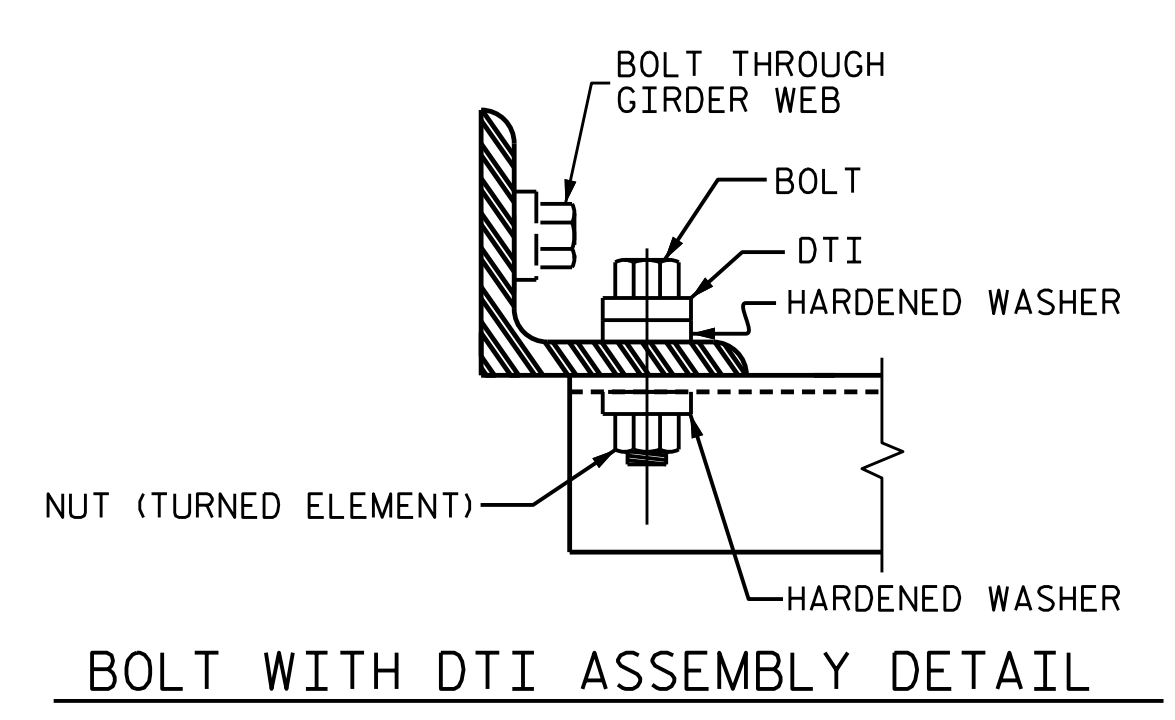

PLATE DETAILS **CHANNEL END**



BOLT WITH DTI ASSEMBLY DETAIL

TABLE

GIRDER TYPE	CHANNEL SIZE	DIM "A"	DIM "B"	DIM "L"
III	MC 18 x 42.7	1'-5"	1'-2"	1'-6"

PROJECT NO. U-4405
CUMBERLAND COUNTY
 STATION: 26+78.00 -RPB-

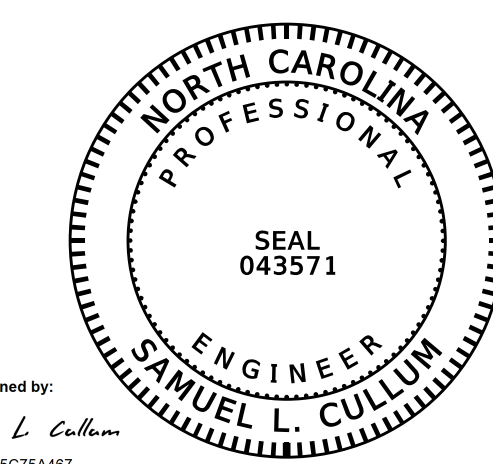

DocuSigned by:
 Samuel L. Cullum
 19C97095C75A467...

6/6/2018 12:30:46 PM PDT

DOCUMENT NOT CONSIDERED
 FINAL UNLESS ALL
 SIGNATURES COMPLETED

STATE OF NORTH CAROLINA
 DEPARTMENT OF TRANSPORTATION
 RALEIGH
 STANDARD
 INTERMEDIATE
 STEEL DIAPHRAGMS
 FOR TYPE III
 PRESTRESSED CONCRETE
 GIRDERS

REVISIONS						SHEET NO.
NO.	BY:	DATE:	NO.	BY:	DATE:	S-10
1			3			TOTAL SHEETS
2			4			26

KCA 4800 SIX FORKS ROAD SUITE 120
 KISINGER CAMPO & ASSOCIATES RALEIGH, NC 27609
 (919) 882-7839

ASSEMBLED BY : J. B. HANNA DATE : 5/17
 CHECKED BY : L. MARTINEZ DATE : 5/17

DRAWN BY : TLA 6/05 ADDED 10/21/05
 CHECKED BY : VC 6/05 REV. 5/1/06RRR KMM/GM

NOTES

AT ALL FIXED POINTS OF SUPPORT, NUTS FOR ANCHOR BOLTS ARE TO BE TIGHTENED FINGER TIGHT AND THEN BACKED OFF 1/2 TURN. THE THREAD OF THE NUT AND BOLT SHALL THEN BE BURRED WITH A SHARP POINTED TOOL.

THE 2" Ø PIPE SLEEVE SHALL BE CUT FROM SCHEDULE 40 PVC PLASTIC PIPE. THE PVC PLASTIC PIPE SHALL MEET THE REQUIREMENTS OF ASTM D1785.

STEEL SOLE PLATES, ANCHOR BOLTS, NUTS, AND WASHERS SHALL BE GALVANIZED IN ACCORDANCE WITH THE STANDARD SPECIFICATIONS.

PRIOR TO WELDING, GRIND THE GALVANIZED SURFACE OF THE PORTION OF THE EMBEDDED PLATE AND SOLE PLATE THAT ARE TO BE WELDED. AFTER WELDING, DAMAGED GALVANIZED SURFACES SHALL BE REPAIRED IN ACCORDANCE WITH THE STANDARD SPECIFICATIONS.

WHEN WELDING THE SOLE PLATE TO THE EMBEDDED PLATE IN THE GIRDER, USE TEMPERATURE INDICATING WAX PENS, OR OTHER SUITABLE MEANS, TO ENSURE THAT THE TEMPERATURE OF THE SOLE PLATE DOES NOT EXCEED 300°F. TEMPERATURES ABOVE THIS MAY DAMAGE THE ELASTOMER.

SOLE PLATE "P", BOLTS, NUTS, WASHERS, AND PIPE SLEEVE SHALL BE INCLUDED IN THE PAY ITEM FOR PRESTRESSED CONCRETE GIRDERS.

ANCHOR BOLTS SHALL MEET THE REQUIREMENTS OF ASTM A449. NUTS SHALL MEET THE REQUIREMENTS OF AASHTO M291-DH OR AASHTO M292-2H. WASHERS SHALL MEET THE REQUIREMENTS OF AASHTO M293. SHOP DRAWINGS ARE NOT REQUIRED FOR ANCHOR BOLT, NUTS AND WASHERS. SHOP INSPECTION IS REQUIRED.

ALL SURFACES OF BEARING PLATES SHALL BE SMOOTH AND STRAIGHT.

THE ELASTOMER IN THE STEEL REINFORCED BEARINGS SHALL HAVE A SHEAR MODULUS OF 0.160 KSI, IN ACCORDANCE WITH AASHTO M251.

FOR STEEL REINFORCED ELASTOMERIC BEARINGS, SEE SPECIAL PROVISIONS.

ALL SOLE PLATES SHALL BE AASHTO M270 GRADE 36 STEEL.

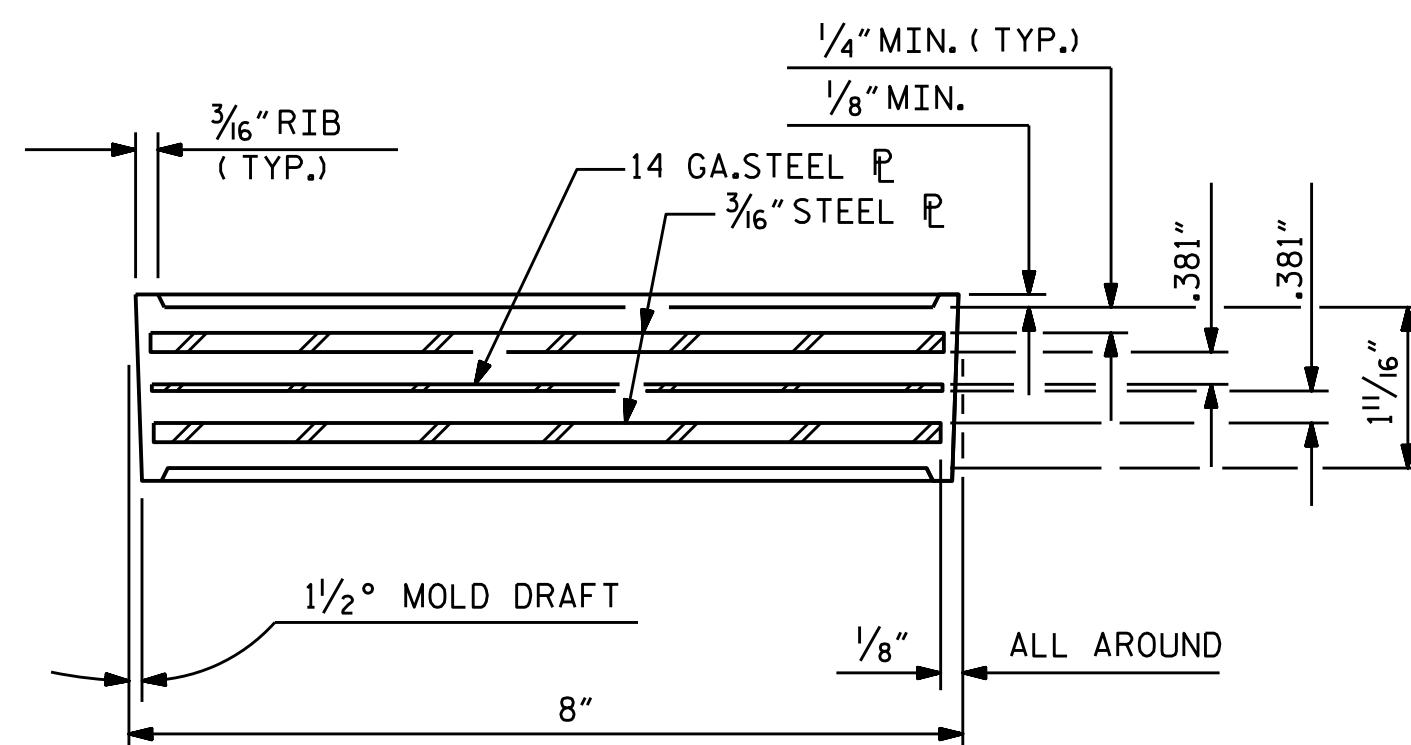
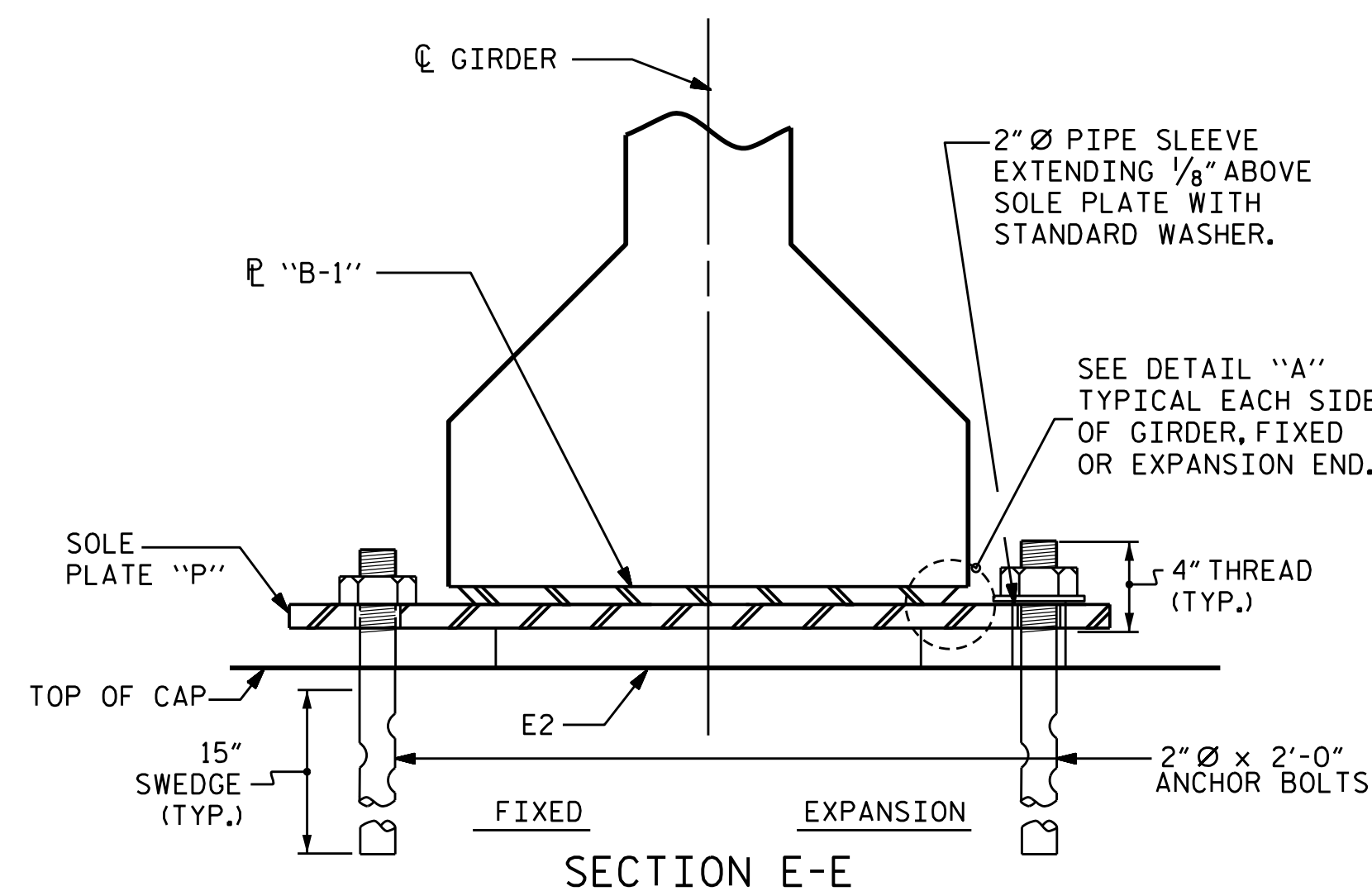

TYPICAL SECTION OF ELASTOMERIC BEARINGS

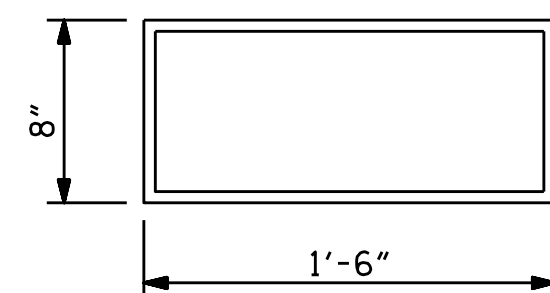

E2 (10 REQ'D)

PLAN VIEW OF ELASTOMERIC BEARING

TYPE III

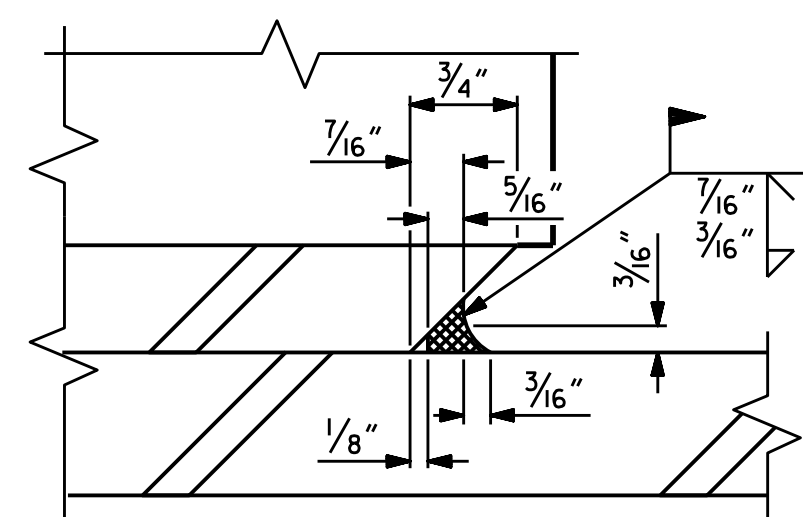

DETAIL "A"

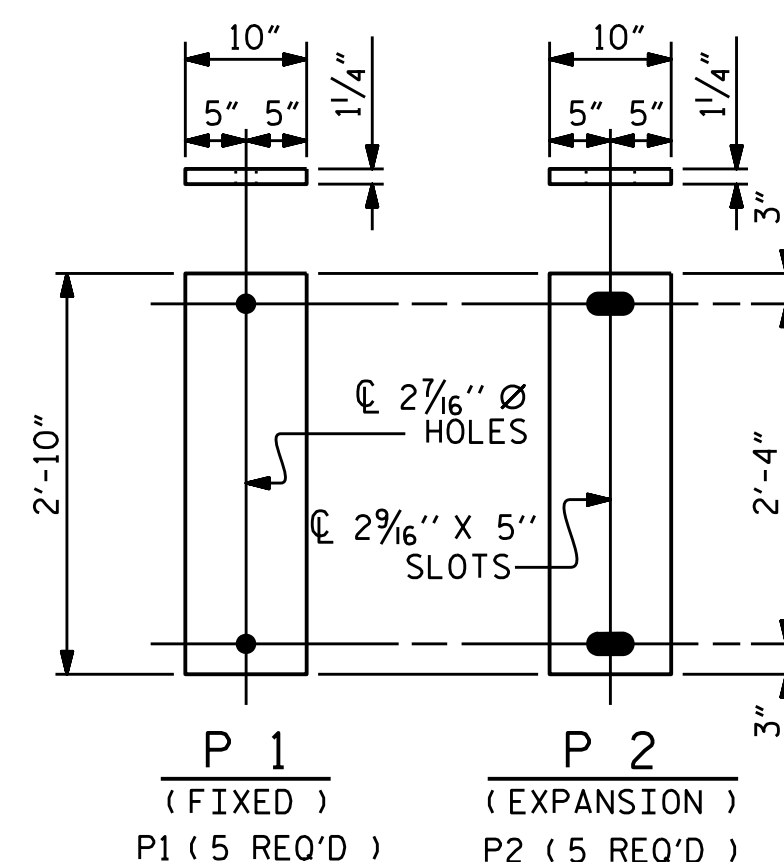

SOLE PLATE DETAILS ("P")

MAXIMUM ALLOWABLE SERVICE LOADS	
D.L.+L.L. (NO IMPACT)	
TYPE III	205 k

PROJECT NO. U-4405
CUMBERLAND COUNTY
 STATION: 26+78.00 -RPB-

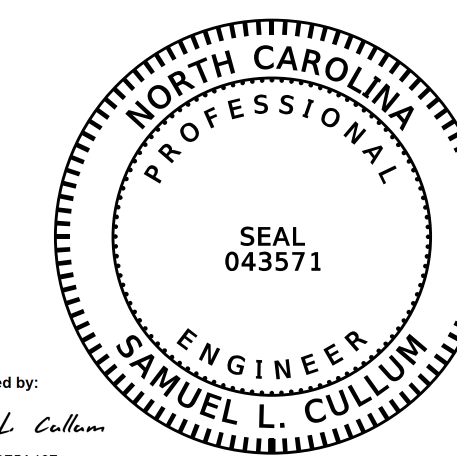

6/6/2018 12:30:46 PM PDT

DOCUMENT NOT CONSIDERED FINAL UNLESS ALL SIGNATURES COMPLETED

STATE OF NORTH CAROLINA
 DEPARTMENT OF TRANSPORTATION
 RALEIGH
 STANDARD
 ELASTOMERIC BEARING DETAILS
 PRESTRESSED CONCRETE GIRDER SUPERSTRUCTURE

REVISIONS						SHEET NO.
NO.	BY:	DATE:	NO.	BY:	DATE:	S-11
1			3			TOTAL SHEETS
2			4			26

KCA 4800 SIX FORKS ROAD SUITE 120
 KISINGER CAMPO & ASSOCIATES RALEIGH, NC 27609
 (919) 882-7839

ASSEMBLED BY : J. B. HANNA DATE : 05-17
 CHECKED BY : L. MARTINEZ DATE : 05-17

DRAWN BY : WJH 8/89 REV. 10/1/11 MAA/GM
 CHECKED BY : CRK 8/89 REV. 6/13 AAC/MAA
 REV. 1/15 MAA/TMG

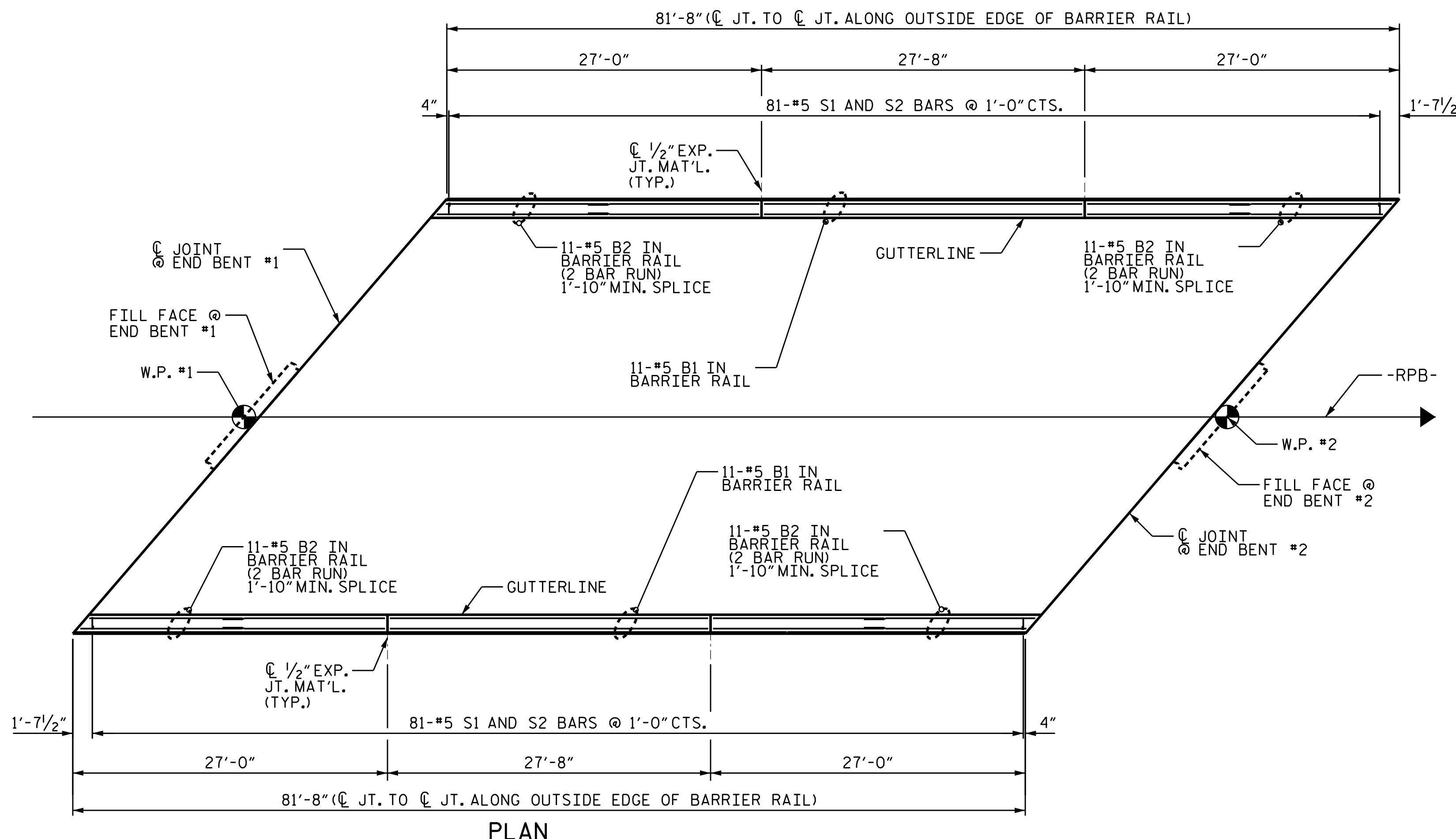

PLAN

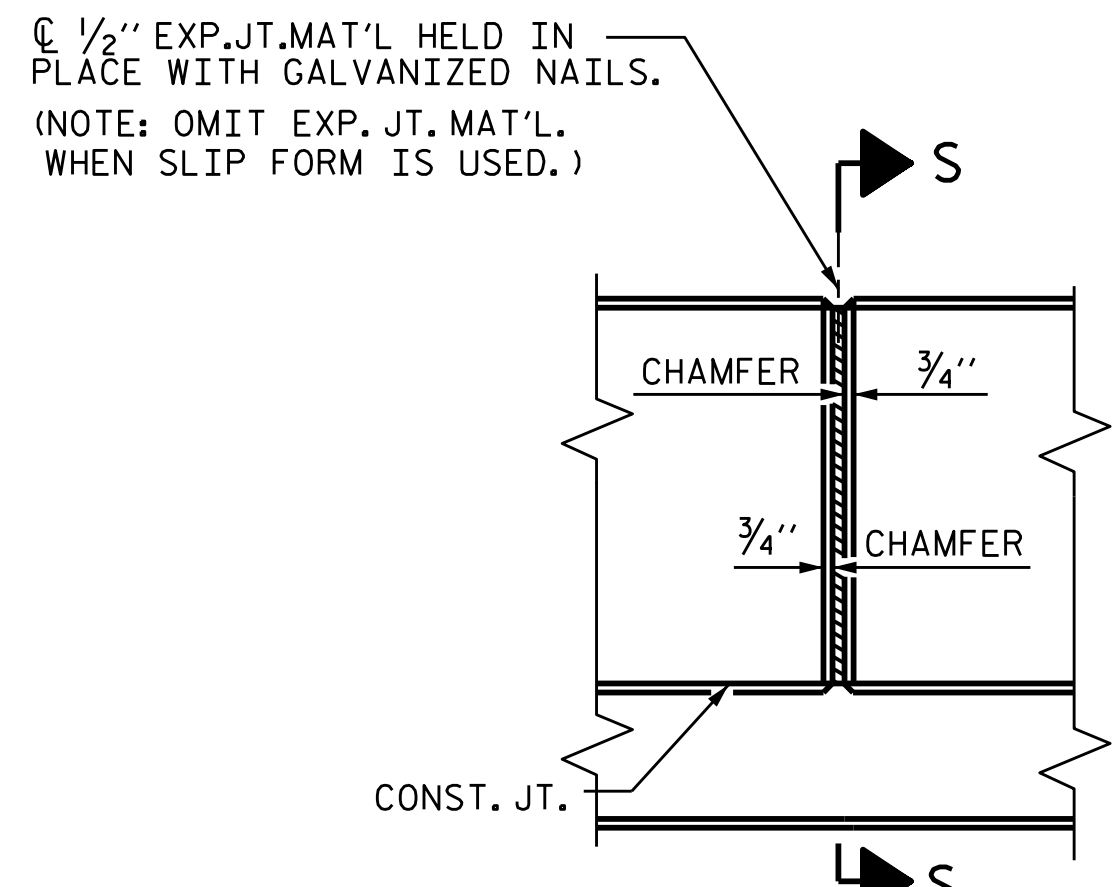

ELEVATION AT EXPANSION JOINTS

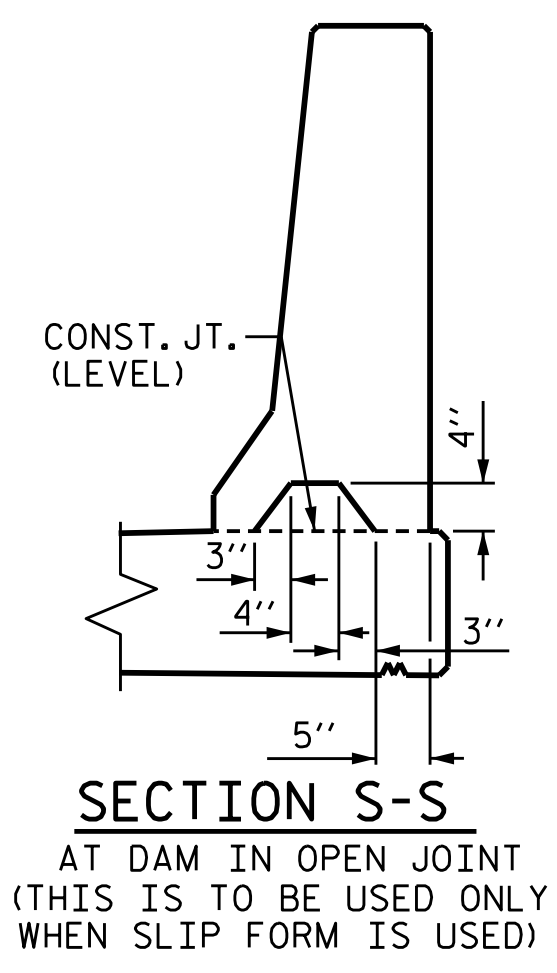

SECTION S-S
AT DAM IN OPEN JOINT
(THIS IS TO BE USED ONLY
WHEN SLIP FORM IS USED)

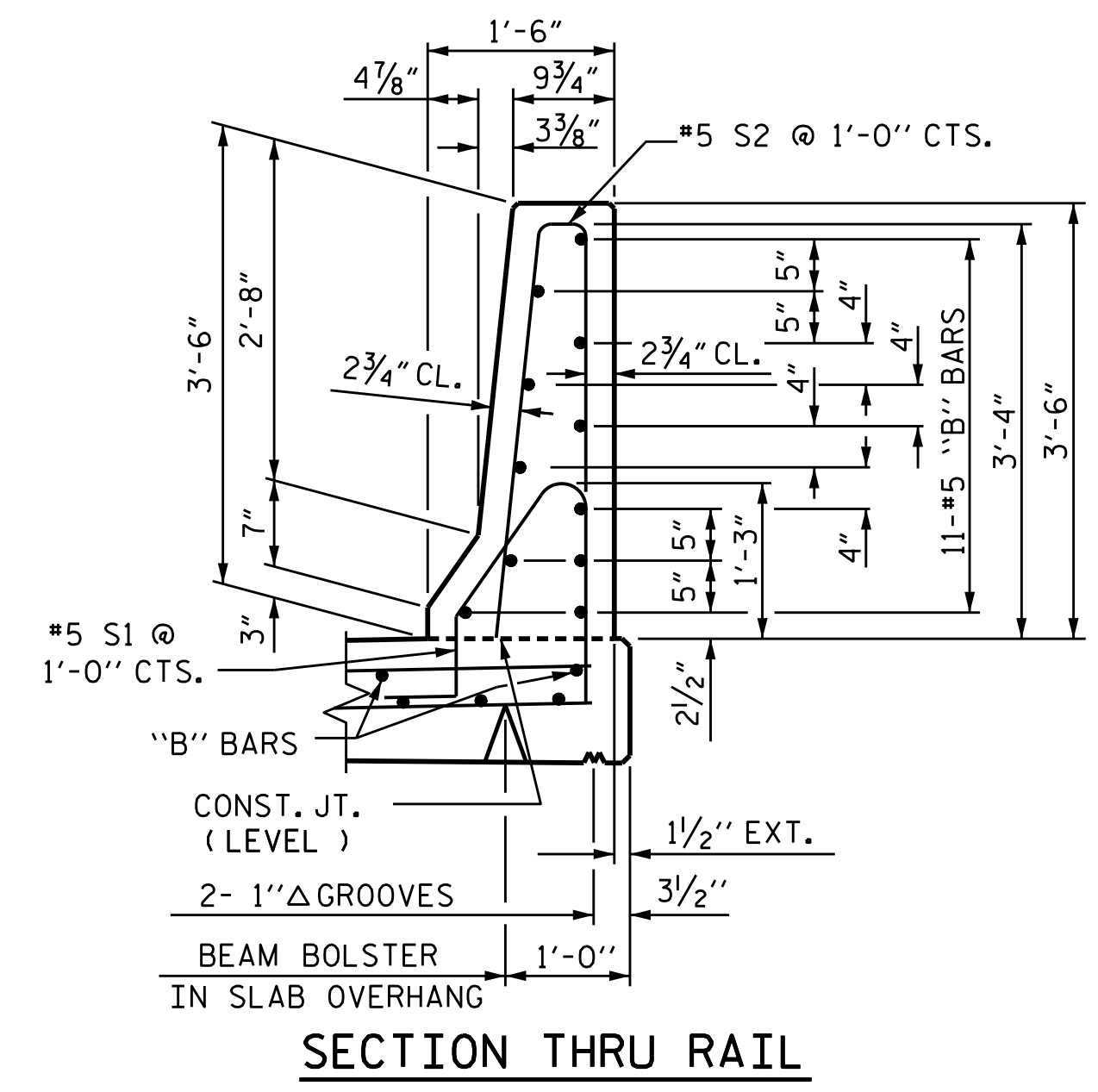

SECTION THRU RAIL

NOTES

THE BARRIER RAIL IN EACH SPAN SHALL NOT BE CAST UNTIL ALL SLAB CONCRETE IN THAT SPAN HAS BEEN CAST AND HAS REACHED A MINIMUM COMPRESSIVE STRENGTH OF 3,000 PSI.
ALL REINFORCING STEEL IN BARRIER RAILS SHALL BE EPOXY COATED.
GROOVED CONTRACTION JOINTS, 1/2" IN DEPTH, SHALL BE TOOLED IN ALL EXPOSED FACES OF THE BARRIER RAIL AND IN ACCORDANCE WITH ARTICLE 825-10(B) OF THE STANDARD SPECIFICATIONS. THE CONTRACTION JOINT SHALL BE LOCATED AT EACH THIRD POINT BETWEEN BARRIER RAIL EXPANSION JOINTS. ONLY ONE CONTRACTION JOINT IS REQUIRED AT MIDPOINT OF BARRIER RAIL SEGMENTS LESS THAN 20 FEET IN LENGTH AND NO CONTRACTION JOINTS ARE REQUIRED FOR THOSE SEGMENTS LESS THAN 10 FEET IN LENGTH.

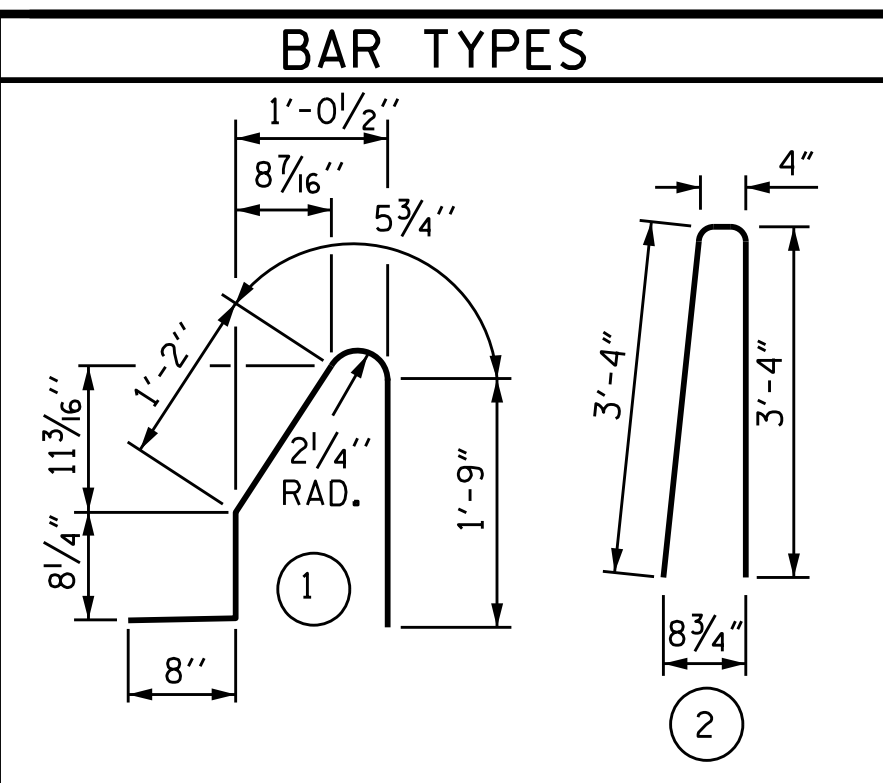

ALL BAR DIMENSIONS ARE OUT TO OUT

BILL OF MATERIAL

FOR CONCRETE BARRIER RAIL ONLY					
BAR	NO.	SIZE	TYPE	LENGTH	WEIGHT
* B1	22	#5	STR	27'-3"	625
* B2	88	#5	STR	14'-6"	1331
* S1	162	#5	1	4'-9"	803
* S2	162	#5	2	7'-0"	1183
* EPOXY COATED REINFORCING STEEL 3942 LBS.					
CLASS AA CONCRETE 22.2 CU. YDS.					
CONCRETE BARRIER RAIL 163.3 LTN. FT.					

PROJECT NO. U-4405
CUMBERLAND COUNTY
STATION: 26+78.00 -RPB-

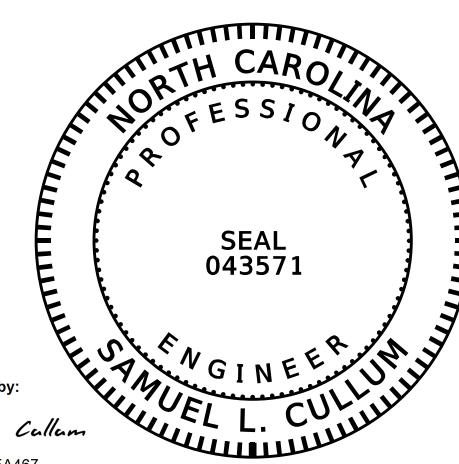

6/6/2018 12:30:46 PM PDT

DOCUMENT NOT CONSIDERED
FINAL UNLESS ALL
SIGNATURES COMPLETED

REVISIONS						SHEET NO.
NO.	BY:	DATE:	NO.	BY:	DATE:	S-12
1			3			TOTAL SHEETS
2			4			26

KCA 4800 SIX FORKS ROAD SUITE 120
KISINGER CAMPO & ASSOCIATES RALEIGH, NC 27609
(919) 882-7839

ASSEMBLED BY : J. B. HANNA DATE : 05-17
CHECKED BY : L. MARTINEZ DATE : 05-17

DRAWN BY : ARB 5/87 REV. 10/1/11 MAA/GM
CHECKED BY : SJD 9/87 REV. 7/12 MAA/GM
REV. 6/13 MAA/GM

BARRIER RAIL DETAILS

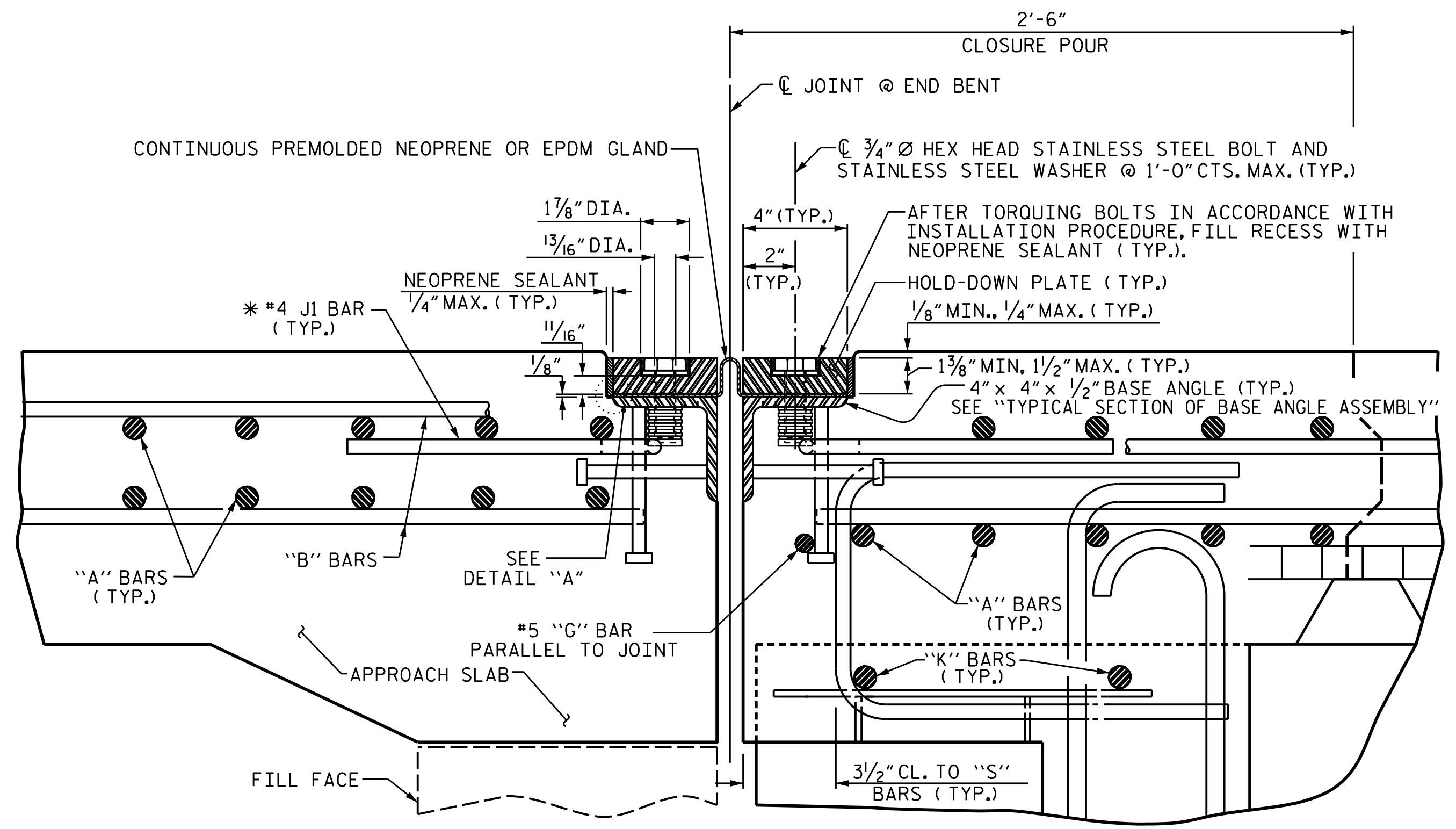

EXPANSION JOINT DETAILS

SECTION NORMAL TO JOINT -- PRESTRESSED GIRDER SUPERSTRUCTURE

* THE QUANTITY OF #4 J1 BARS ON THE BILL OF MATERIAL IS BASED ON 1'-0" CENTERS. J1 BARS SHALL BE PLACED AT EACH VERTICAL STUD ANCHOR BOLT. IN THE EVENT THAT THE NUMBER OF VERTICAL STUD ANCHORS EXCEEDS THE NUMBER OF J1 BARS SPECIFIED, ADDITIONAL J1 BARS WILL NOT BE REQUIRED.

INSTALLATION PROCEDURE

1. A TEMPLATE OR OTHER SUITABLE DEVICE SHALL BE USED TO FORM THE TOP OF THE EXPANSION JOINT SEAL BLOCKOUT TO THE PROPER DEPTH AND WIDTH. THE TEMPLATE SHALL BE 4/8" TO 4/4" WIDE AND OF SUCH THICKNESS AS TO PROVIDE FOR CORRECT FINAL ELEVATION OF TOP OF HOLD-DOWN PLATES. THE TEMPLATE SHALL BE ATTACHED TO THE BASE ANGLE ASSEMBLY WITH THE 3/4" Ø HEX HEAD BOLTS PROVIDED FOR THE HOLD-DOWN PLATES. A 1" Ø HOLE SHALL BE PROVIDED IN THE TEMPLATE CENTERED OVER EACH WEEP HOLE IN THE 4" X 4" X 1/2" BASE ANGLE. OTHER METHODS OF INSURING DRAINAGE THROUGH WEEP HOLES MAY BE EMPLOYED SUBJECT TO ENGINEER'S APPROVAL.
2. AFTER THE CONCRETE HAS BEEN CAST ON BOTH SIDES OF THE JOINT, REMOVE THE TEMPLATE. THOROUGHLY CLEAN THE BOLT HOLES AND THE ANGLE PLATE. REMOVE ANY EXCESS CONCRETE THAT COMES OUT OF THE WEEP HOLES. ANY DAMAGED STEEL SHALL BE COATED WITH A MINIMUM THICKNESS OF 4 DRY MILS OF ZINC-RICH PAINT IN ACCORDANCE WITH THE STANDARD SPECIFICATIONS.
3. LAY THE GLAND ON THE BASE ANGLE AND FIELD MARK THE GLAND FOR THE BOLT HOLES. HOLES IN THE GLAND SHALL BE PUNCHED 7/8" IN DIAMETER WITH A HAND PUNCH.
4. IN ORDER TO CHECK FOR PROPER ALIGNMENT, PLACE THE GLAND AND HOLD-DOWN PLATES ON THE BASE ANGLE. DO NOT APPLY NEOPRENE SEALANT. BOLT THE HOLD-DOWN PLATES TO THE BASE ANGLE BUT DO NOT TIGHTEN. THE ENGINEER SHALL INSPECT THE JOINT SEAL DEVICE FOR PROPER ALIGNMENT.
5. AFTER INSPECTION, REMOVE THE HOLD-DOWN PLATES AND GLAND. APPLY NEOPRENE SEALANT TO THE BASE ANGLE IN ACCORDANCE WITH THE "INSTALLATION SKETCH". PLACE GLAND AND HOLD-DOWN PLATES ON THE BASE ANGLE. BOLT THE HOLD-DOWN PLATES TO THE BASE ANGLE ASSEMBLY AND TORQUE THE BOLTS TO 88 FT-LBS WITH A TORQUE WRENCH. CHECK THE TORQUE AFTER THREE (3) HOURS AND, IF NECESSARY, RETIGHTEN TO 88 FT-LBS. A FINAL CHECK SHALL BE MADE AT SEVEN (7) DAYS. TORQUE SHALL NOT BE LESS THAN 80 FT-LBS AFTER SEVEN (7) DAYS.
6. AFTER PROPER TORQUING, CLEAN THE BOLT HOLE RECESSES AND THE RECESS BETWEEN THE JOINT SEAL DEVICE AND CONCRETE, COMPLETELY FILL THESE RECESSES WITH NEOPRENE SEALANT.

GENERAL NOTES

1. FOR EXPANSION JOINT SEALS, SEE SPECIAL PROVISIONS.
2. ALL PLATES AND ANGLES SHALL CONFORM TO AASHTO M270 GRADE 36 STEEL OR APPROVED EQUAL. ALL HOLD-DOWN BOLTS SHALL CONFORM TO ASTM F593 ALLOY 304 STAINLESS STEEL AND WASHERS SHALL CONFORM TO ASTM F844 EXCEPT THEY SHALL BE MADE FROM ALLOY 304 STAINLESS STEEL. ALL STUD ANCHORS SHALL CONFORM TO AASHTO M169, GRADES 1010 THRU 1020 OR APPROVED EQUAL. ALL CONCRETE INSERTS SHALL BE CLOSED END AND SHALL CONFORM TO AASHTO M169, GRADE 12L14. TENSILE CAPACITY SHALL BE 3000 LBS. MIN.
3. A PREMOLDED CORRUGATED OR NON-CORRUGATED GLAND SHALL BE USED FOR JOINTS SKEWED BETWEEN 50° THRU 130°. FOR JOINTS SKEWED LESS THAN 50° OR MORE THAN 130°, ONLY A CORRUGATED GLAND SHALL BE USED.
4. CLOSED END FERRULES AND STUD ANCHORS SHALL BE SHOP WELDED AND ALL HOLES SHALL BE SHOP DRILLED AS SHOWN ON PLANS. STUD ANCHORS SHALL BE ELECTRIC ARC END WELDED WITH COMPLETE FUSION.
5. SURFACES COMING IN CONTACT WITH NEOPRENE SHALL BE GROUND SMOOTH PRIOR TO METALLIZING.
6. UPON COMPLETION OF SHOP FABRICATION, THE HOLD DOWN PLATE AND BASE ANGLE ASSEMBLY, AS SHOWN IN THE "TYPICAL SECTION OF BASE ANGLE ASSEMBLY", SHALL BE METALLIZED. SEE SPECIAL PROVISION FOR THERMAL SPRAYED COATINGS (METALLIZATION).
7. BASE ANGLE ASSEMBLY SHALL BE CONTINUOUS FOR THE LENGTH OF THE JOINT. AT CROWN BREAKS, THE ENDS OF THE BASE ANGLE ASSEMBLY SHALL BE CUT PARALLEL TO THE BRIDGE CENTERLINE FOR SKEWS LESS THAN 80° AND GREATER THAN 100°. FINISHED WELD SHALL BE GROUND SMOOTH AND COATED WITH A MINIMUM THICKNESS OF 4 DRY MILS OF ZINC-RICH PAINT IN ACCORDANCE WITH THE STANDARD SPECIFICATIONS.
8. FIELD SPLICES OF HOLD-DOWN PLATES SHALL BE KEPT TO A MINIMUM. CONTRACTOR SHALL FURNISH DETAILED PLANS SHOWING PROPOSED SPLICE LOCATIONS FOR APPROVAL. HOLD-DOWN PLATES SHALL NOT EXCEED 20' LENGTHS UNLESS APPROVED BY THE ENGINEER.
9. NO ALTERNATE JOINT DETAILS SHALL BE PERMITTED IN LIEU OF THOSE SHOWN ON THESE PLANS.
10. THE CONTRACTOR MAY, AT HIS OPTION, USE ADHESIVELY ANCHORED ANCHOR BOLTS IN PLACE OF CONCRETE INSERTS FOR COVER PLATES. THE YIELD LOAD OF THE 3/4" Ø BOLT IS 10 KIPS. FIELD TESTING OF THE ADHESIVE BONDING SYSTEM IS NOT REQUIRED.

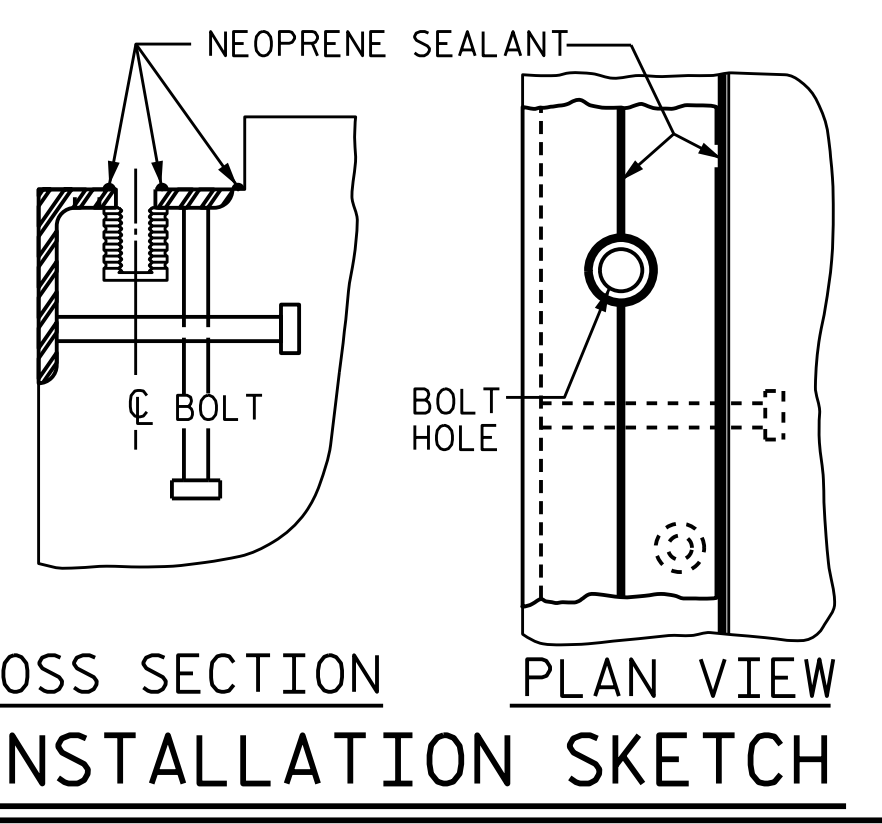
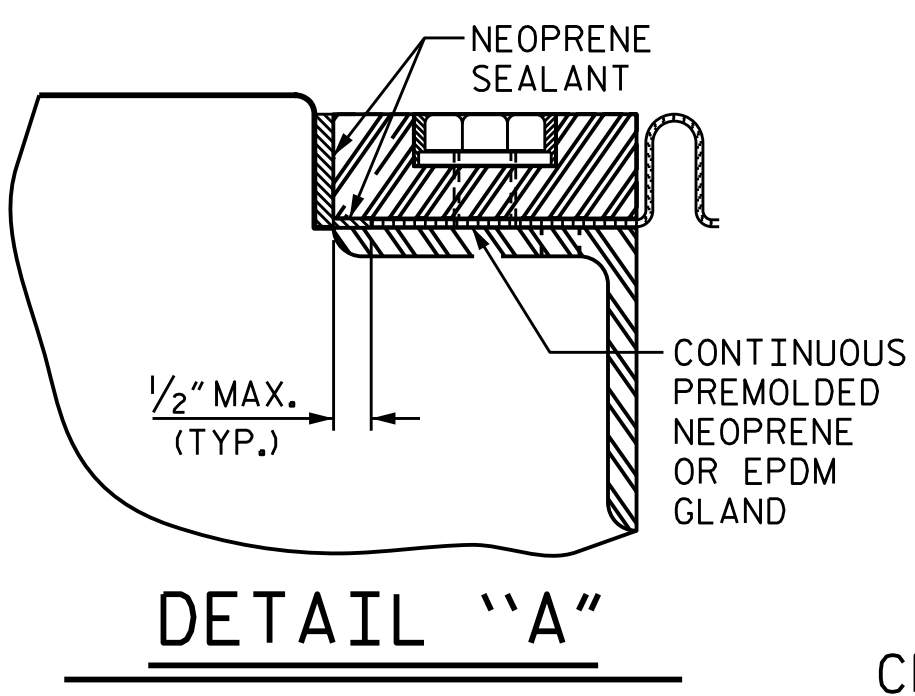

MOVEMENT AND SETTING AT JOINT					
BENT NO.	SKEW ANGLE	TOTAL MOVEMENT (ALONG C RDWY)	PERPENDICULAR JOINT OPENING AT 45° F	PERPENDICULAR JOINT OPENING AT 60° F	PERPENDICULAR JOINT OPENING AT 90° F
1	130° 41' 32"	0"	1"	1"	1"
2	130° 41' 32"	1/2"	1 1/4"	1 3/16"	1 1/16"

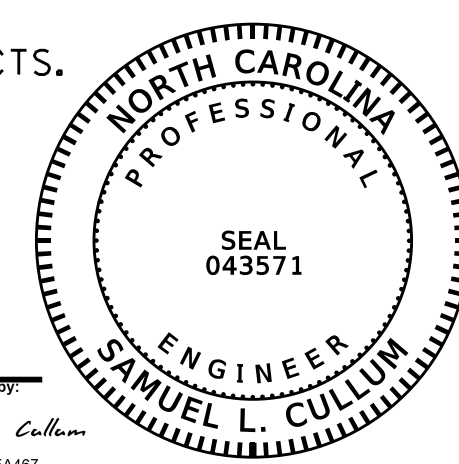
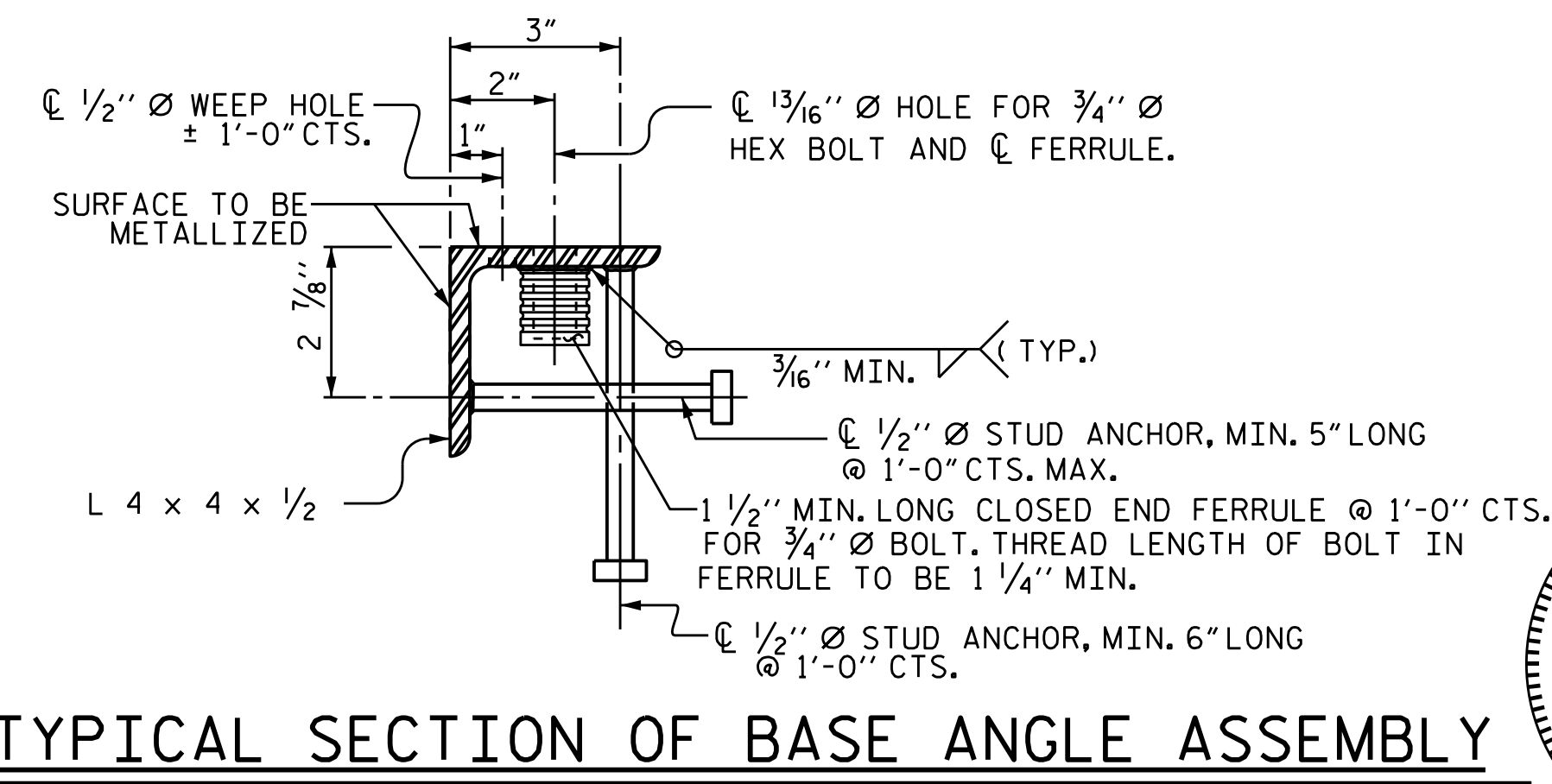
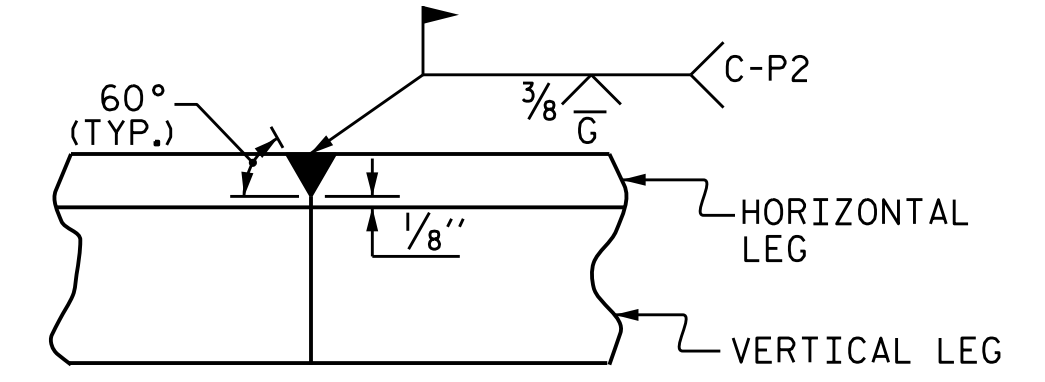

PROJECT NO. U-4405
CUMBERLAND COUNTY
 STATION: 26+78.00 -RPB-

SHEET 1 OF 2

STATE OF NORTH CAROLINA DEPARTMENT OF TRANSPORTATION RALEIGH					
STANDARD EXPANSION JOINT SEAL DETAILS					
REVISIONS					
NO.	BY:	DATE:	NO.	BY:	DATE:
1			3		
2			4		
					SHEET NO. S-13
					TOTAL SHEETS 26

KCA 4800 SIX FORKS ROAD SUITE 120
 RALEIGH, NC 27609
 (919) 882-7839

ASSEMBLED BY : L. MARTINEZ DATE : 06-17
 CHECKED BY : S. BOYD DATE : 06-17

DRAWN BY : REK 9/87 REV. 5/7/03R RWW/JTE
 CHECKED BY : CRK 10/87 REV. 5/1/06R TL4/GM
 REV. 10/1/11 MAA/GM

6/6/2018 12:30:46 PM PDT
 DOCUMENT NOT CONSIDERED
 FINAL UNLESS ALL
 SIGNATURES COMPLETED

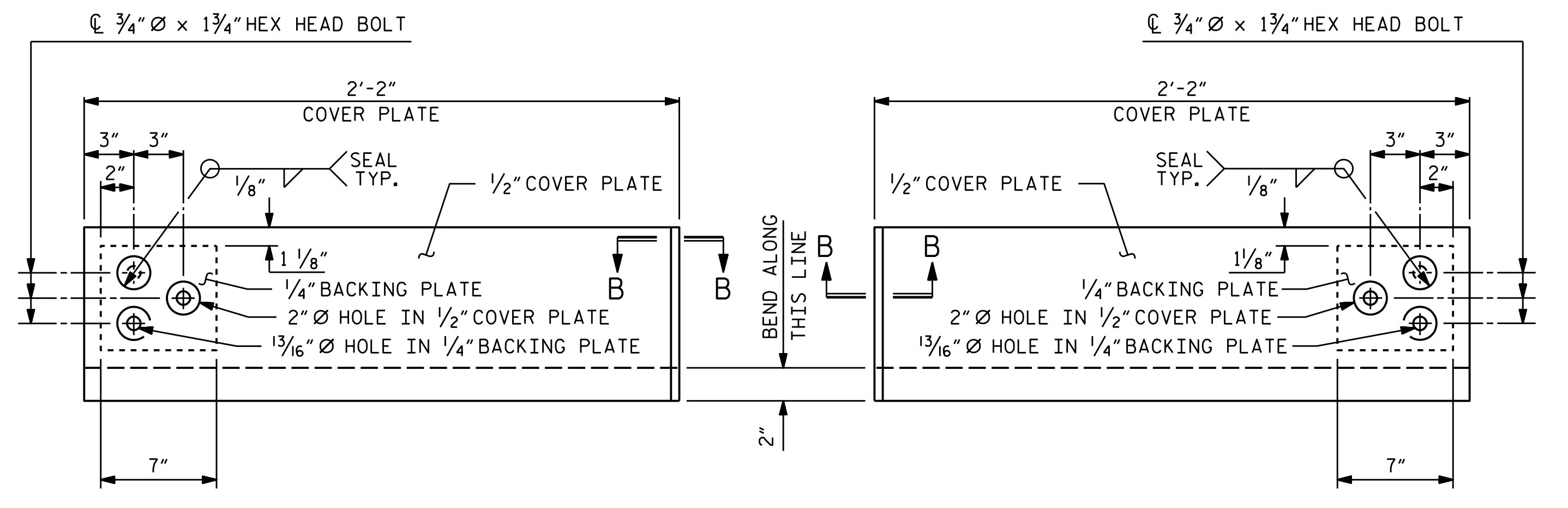
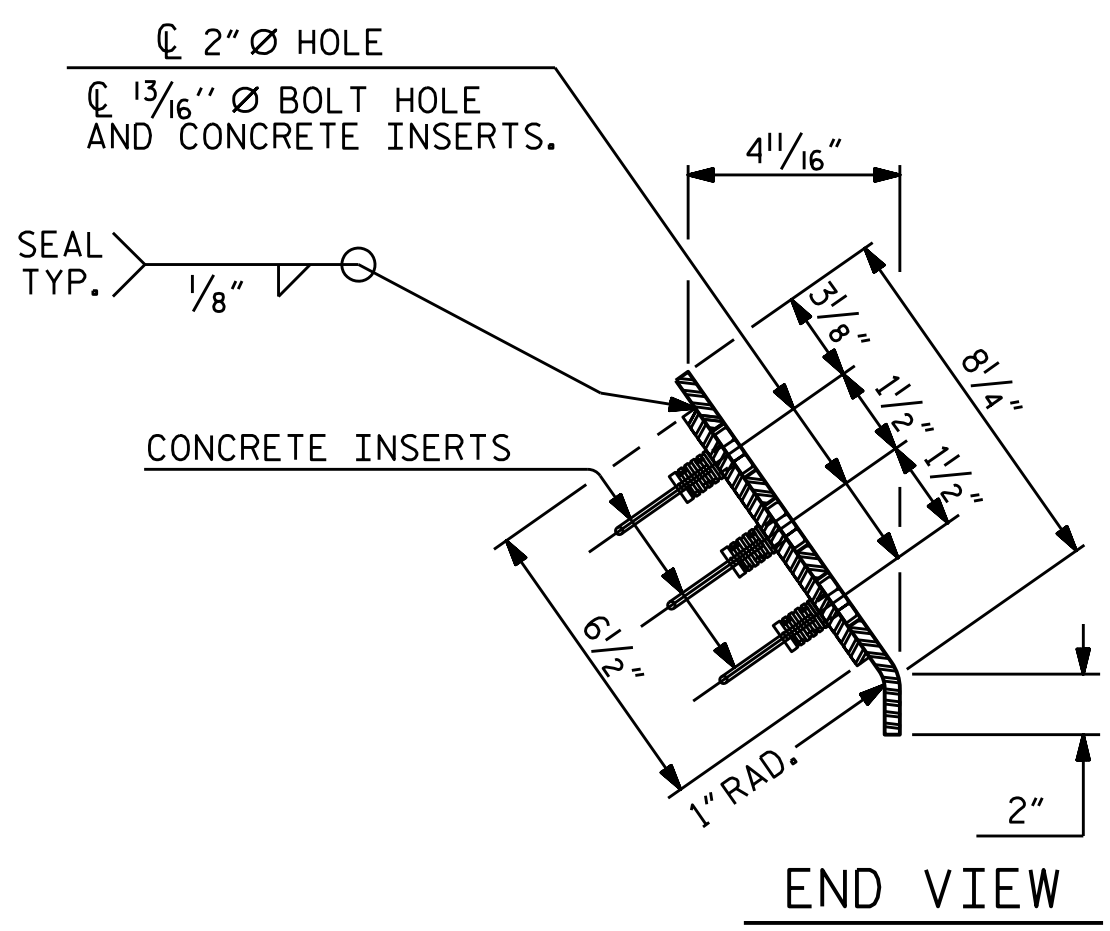
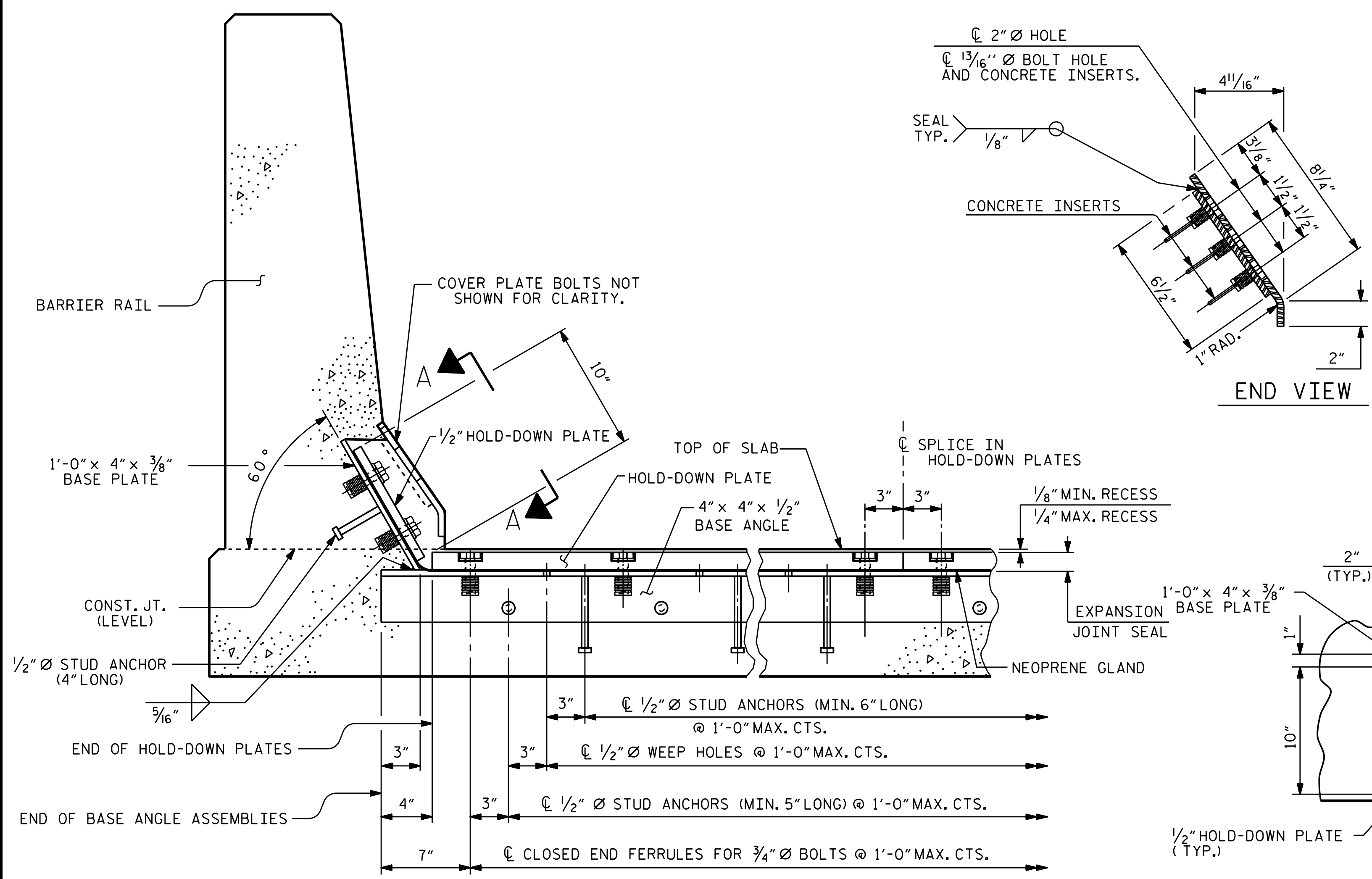

TYPE I - ELEVATION VIEW
TYPE II - ELEVATION VIEW
COVER PLATE DETAILS

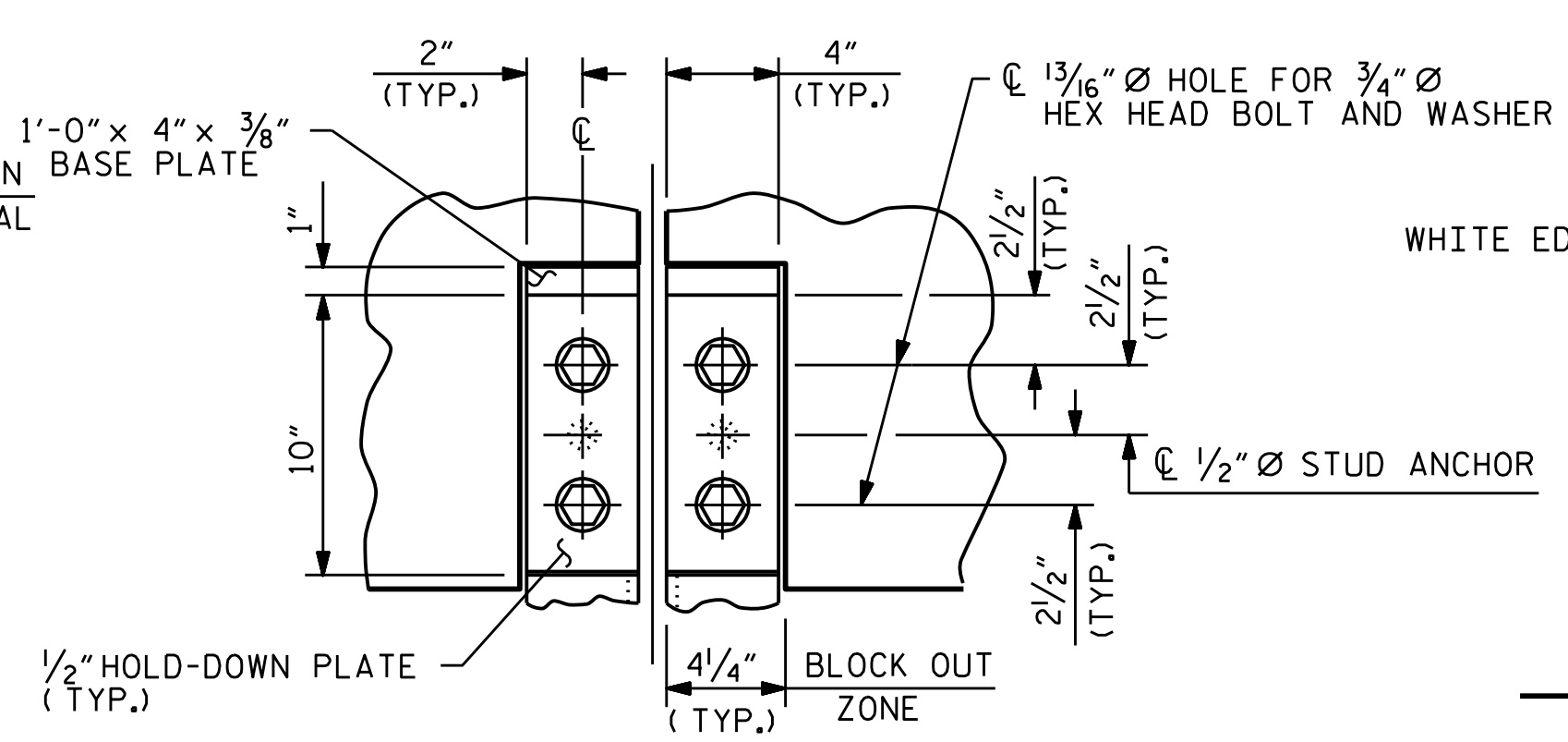

SECTION A - A

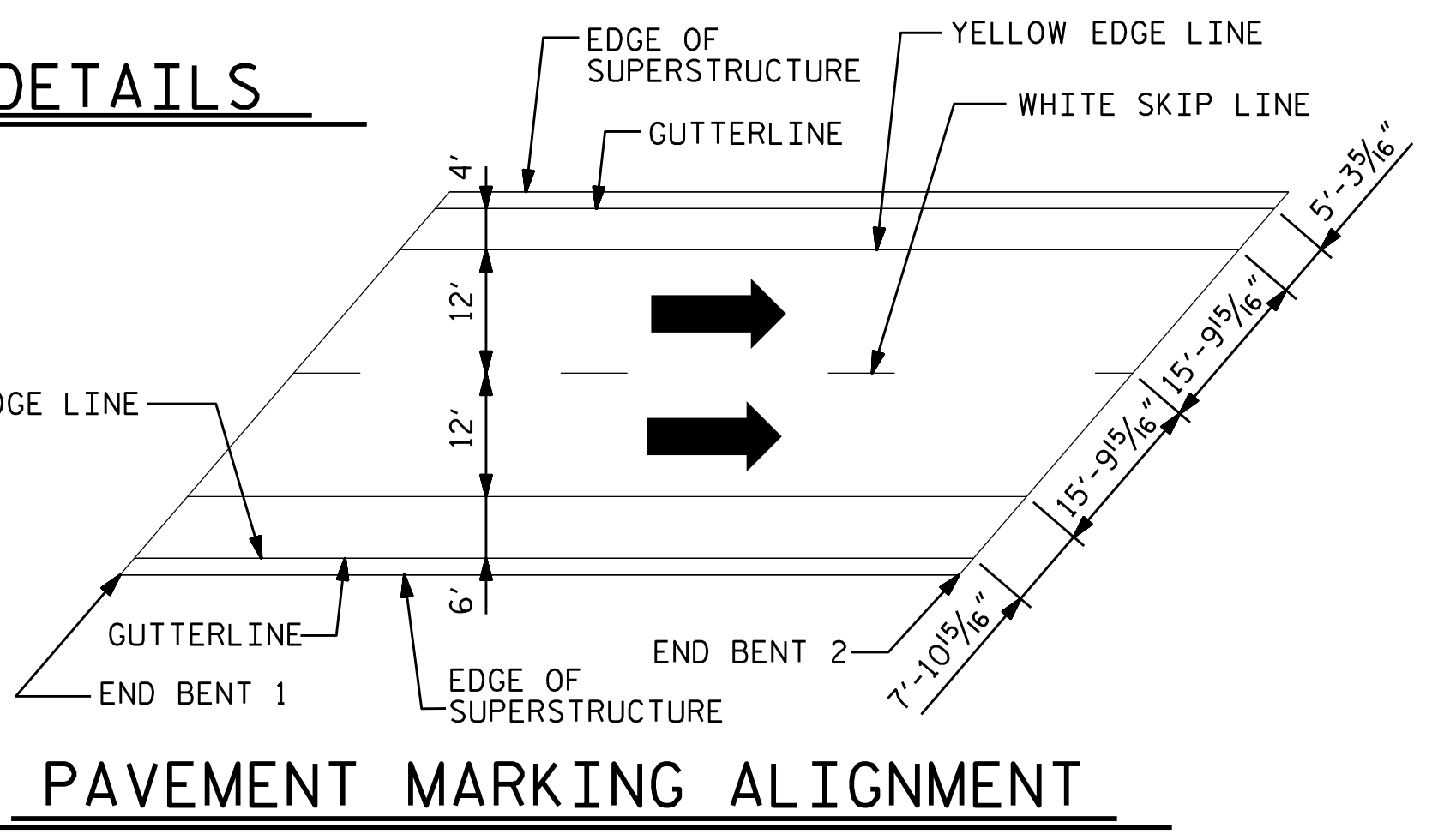

PAVEMENT MARKING ALIGNMENT

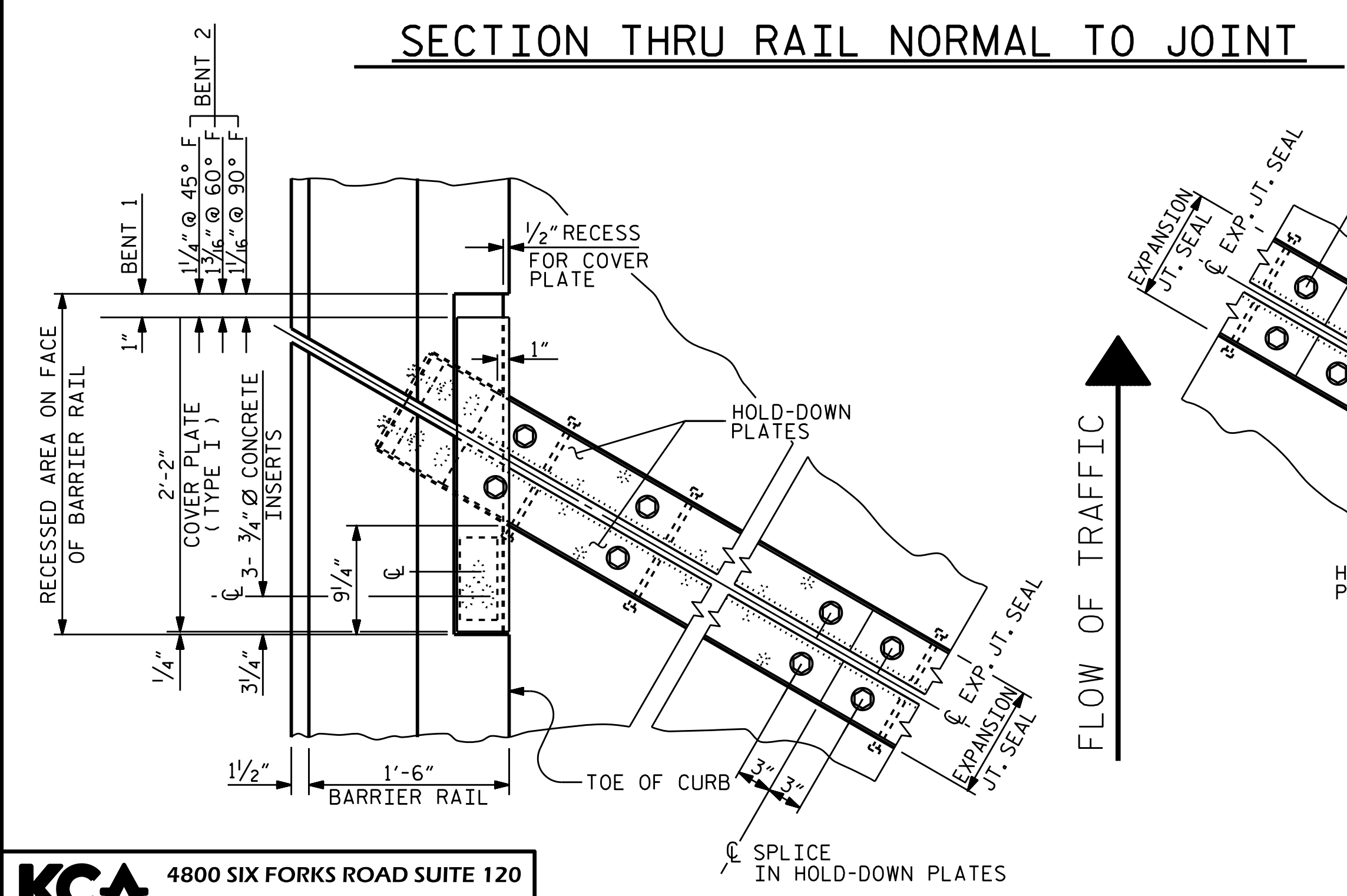

SECTION THRU RAIL NORMAL TO JOINT

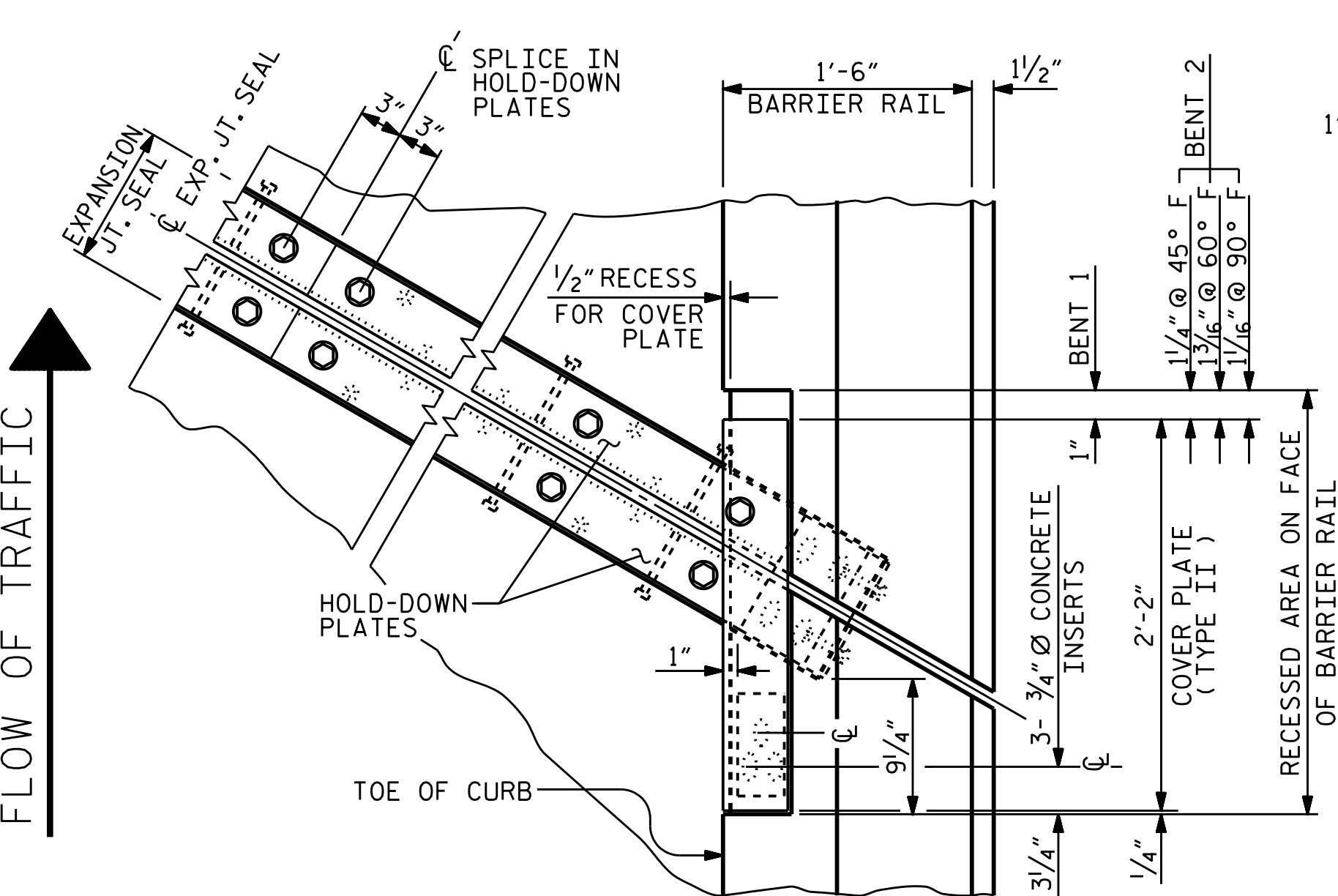

PLAN OF EXPANSION JOINT SEAL

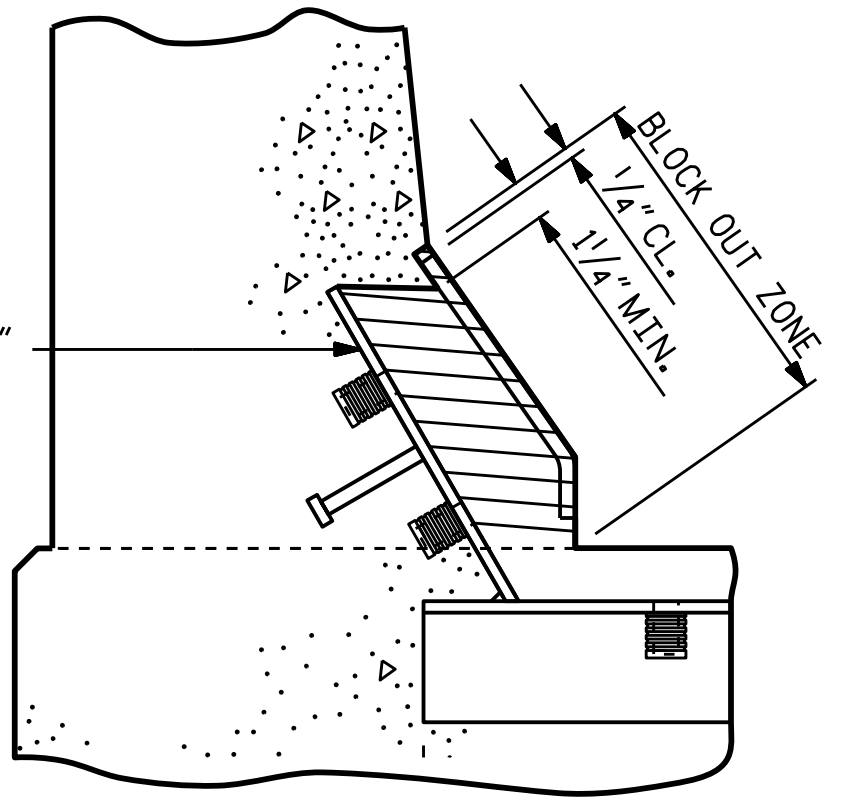

BLOCK OUT DETAIL

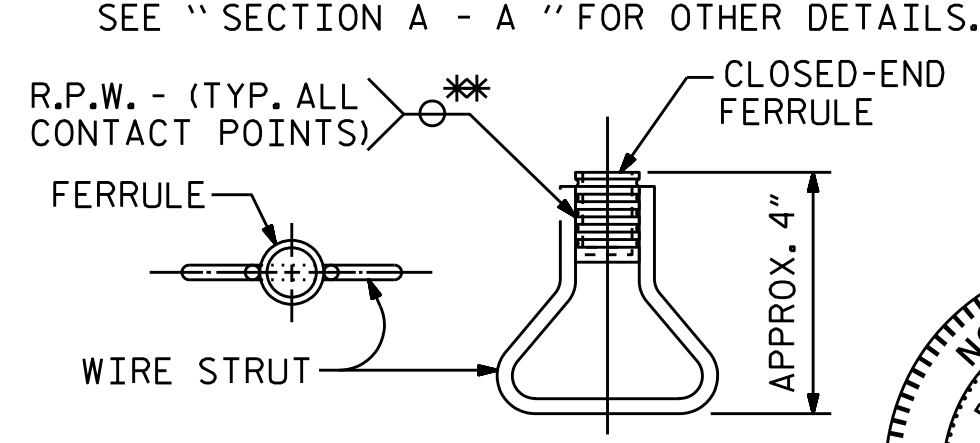

CONCRETE INSERT

* EACH WELDED ATTACHMENT OF WIRE TO FERRULE SHALL DEVELOP THE TENSILE STRENGTH OF THE WIRE.

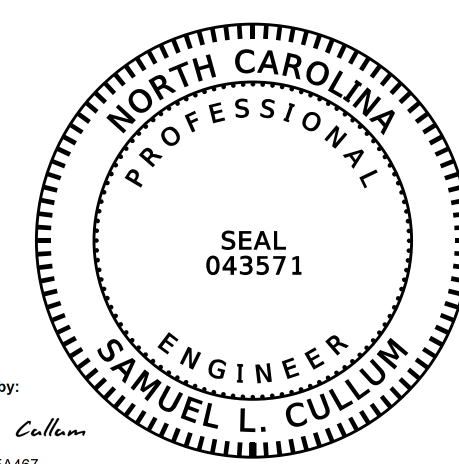

PROJECT NO. U-4405
CUMBERLAND COUNTY
STATION: 26+78.00 -RPB-

SHEET 2 OF 2

STATE OF NORTH CAROLINA
DEPARTMENT OF TRANSPORTATION
RALEIGH
STANDARD
EXPANSION JOINT
SEAL DETAILS
FOR BARRIER RAIL

REVISIONS						SHEET NO.
NO.	BY:	DATE:	NO.	BY:	DATE:	S-14
1			3			TOTAL SHEETS
2			4			26

KCA 4800 SIX FORKS ROAD SUITE 120
KISINGER CAMPO & ASSOCIATES RALEIGH, NC 27609
(919) 882-7839

ASSEMBLED BY : L. MARTINEZ DATE : 06-17
CHECKED BY : S. BOYD DATE : 06-17

DRAWN BY : REK 9/87 MAA/GM
CHECKED BY : CRK 10/87 REV. 10/11/11 MAA/GM
REV. 7/12 MAA/GM
REV. 6/13 MAA/GM

DOCUMENT NOT CONSIDERED FINAL UNLESS ALL SIGNATURES COMPLETED

NOTES

THE GUARDRAIL ANCHOR ASSEMBLY SHALL CONSIST OF A 1/4" HOLD-DOWN PLATE AND 4 - 1/8" Ø BOLTS WITH NUTS AND WASHERS, RUBRAIL, AND ADHESIVELY ANCHORED BOLTS.

THE HOLD-DOWN PLATE SHALL CONFORM TO AASHTO M270 GRADE 36. AFTER FABRICATION, THE HOLD-DOWN PLATE SHALL BE HOT-DIP GALVANIZED IN ACCORDANCE WITH AASHTO M111.

BOLTS SHALL CONFORM TO THE REQUIREMENTS OF ASTM A307 AND NUTS SHALL CONFORM TO THE REQUIREMENTS OF AASHTO M291. BOLTS, NUTS AND WASHERS SHALL BE GALVANIZED. (AT THE CONTRACTOR'S OPTION, STAINLESS STEEL BOLTS, NUTS AND WASHERS MAY BE USED AS AN ALTERNATE FOR THE 1/8" Ø GALVANIZED BOLTS, NUTS AND WASHERS. THEY SHALL CONFORM TO OR EXCEED THE MECHANICAL REQUIREMENTS OF ASTM A307. THE USE OF THIS ALTERNATE SHALL BE APPROVED BY THE ENGINEER.)

THE GUARDRAIL ANCHOR ASSEMBLY IS REQUIRED AT ALL POINTS WHERE APPROACH GUARDRAIL IS TO BE ATTACHED TO THE END OF BARRIER RAIL. FOR POINTS OF ATTACHMENT, SEE SKETCH.

AFTER INSTALLATION, THE EXPOSED THREAD OF THE BOLT SHALL BE BURRED WITH A SHARP POINTED TOOL.

THE COST OF THE GUARDRAIL ANCHOR ASSEMBLY SHALL BE INCLUDED IN THE UNIT CONTRACT PRICE BID FOR CONCRETE BARRIER RAIL.

THE 1 1/4" Ø HOLES SHALL BE FORMED OR DRILLED WITH A CORE BIT. IMPACT TOOLS WILL NOT BE PERMITTED. ANY CONCRETE DAMAGED BY THIS WORK SHALL BE REPAIRED TO THE SATISFACTION OF THE ENGINEER.

THE C6 X 8.2 RUBRAIL IS TO BE ADHESIVELY ANCHORED TO THE RAIL USING THREE 3/4" Ø X 6" BOLTS WITH WASHERS. LEVEL ONE FIELD TESTING IS REQUIRED, AND THE YIELD LOAD OF THE 3/4" Ø BOLT IS 12 KIPS. FOR ADHESIVELY ANCHORED ANCHOR BOLTS OR DOWELS, SEE STANDARD SPECIFICATIONS. SEE ROADWAY STANDARD 862.03 FOR DETAILS AND LOCATION OF THE RUBRAIL.

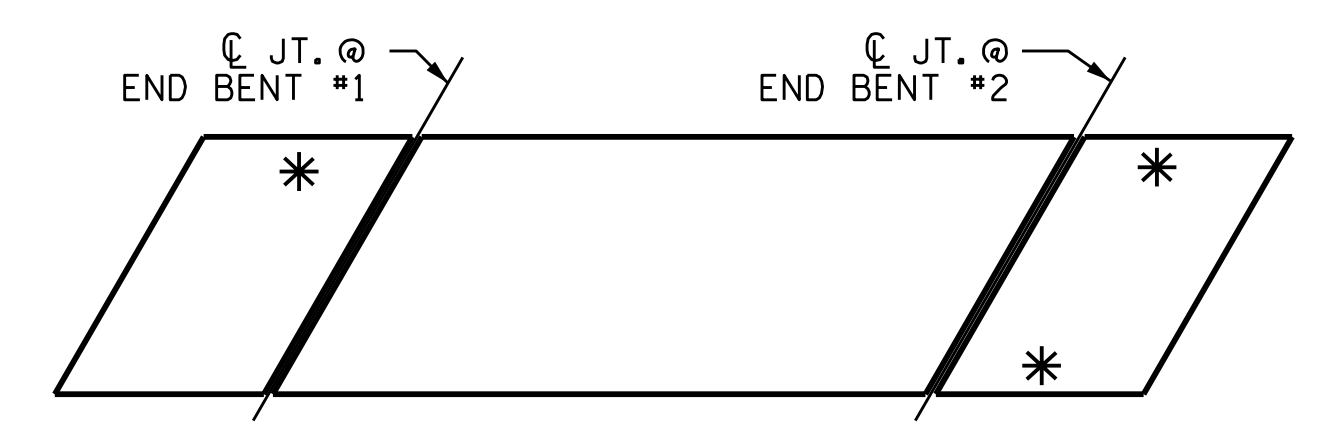
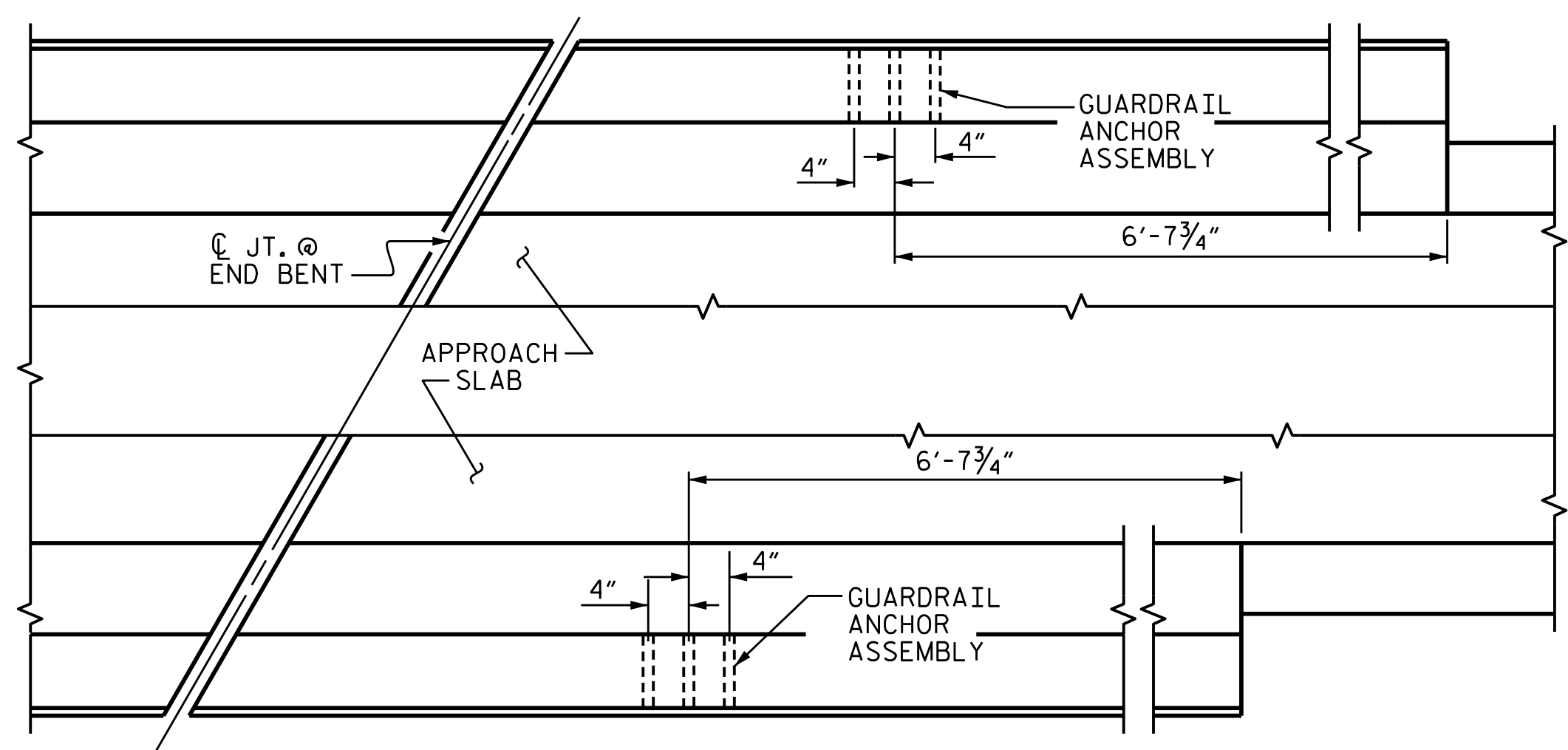
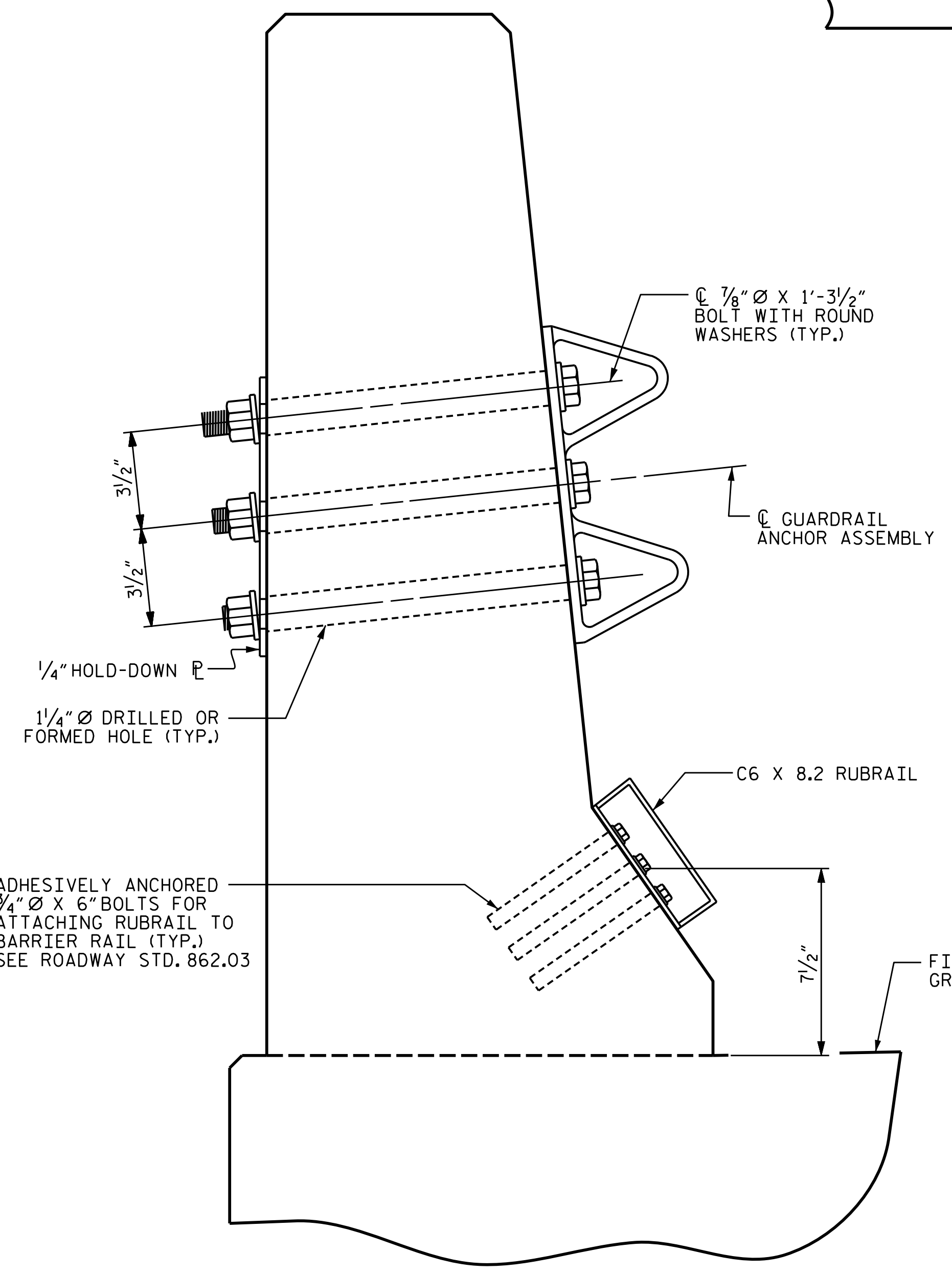
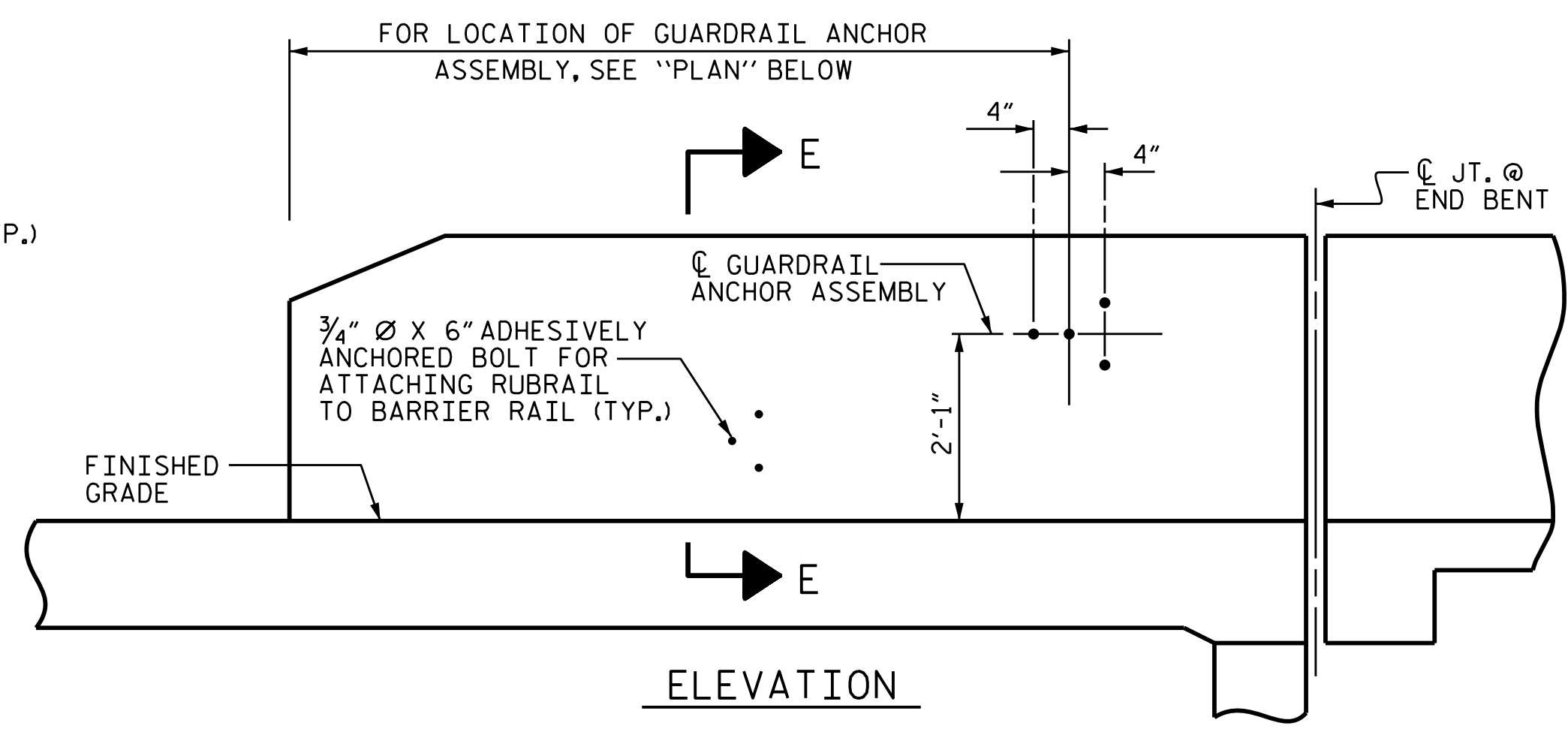
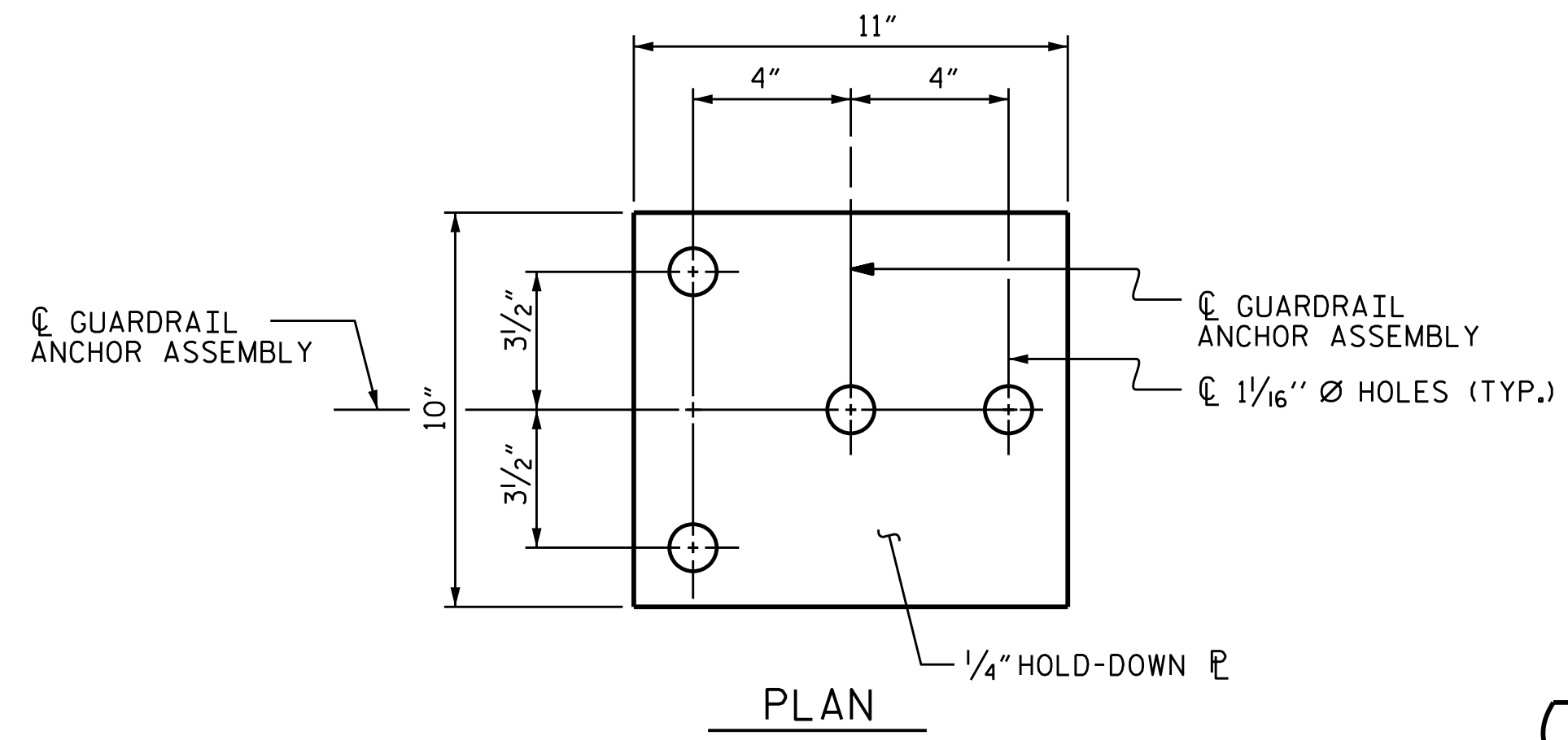

SKETCH SHOWING POINTS OF ATTACHMENTS

* DENOTES GUARDRAIL ANCHOR ASSEMBLY

LOCATION OF ANCHORS FOR GUARDRAIL

END BENT #2 SHOWN, END BENT #1 SIMILAR.

SECTION E-E
GUARDRAIL ANCHOR ASSEMBLY DETAILS

PROJECT NO. U-4405
CUMBERLAND COUNTY
STATION: 26+78.00 -RPB-

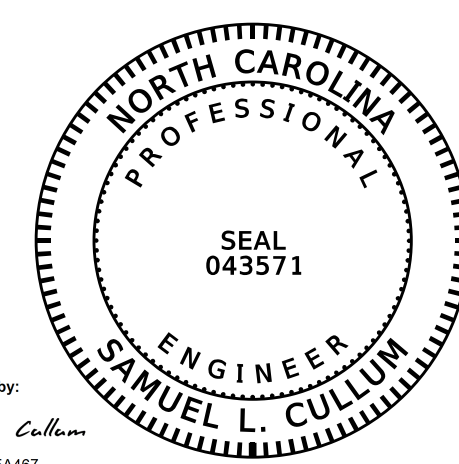

6/6/2018 12:30:46 PM PDT

DOCUMENT NOT CONSIDERED FINAL UNLESS ALL SIGNATURES COMPLETED

STATE OF NORTH CAROLINA DEPARTMENT OF TRANSPORTATION RALEIGH						SHEET NO. S-15
STANDARD GUARDRAIL ANCHORAGE FOR BARRIER RAIL						TOTAL SHEETS 26
REVISIONS						
NO.	BY:	DATE:	NO.	BY:	DATE:	
1			3			
2			4			

KCA 4800 SIX FORKS ROAD SUITE 120 KISINGER CAMPO & ASSOCIATES RALEIGH, NC 27609 (919) 882-7839					
ASSEMBLED BY : J. B. HANNA	DATE : 05-17	MAA/GM			
CHECKED BY : L. MARTINEZ	DATE : 05-17	MAA/GM			
DRAWN BY : TLA 5/06	REV. 10/1/11	MAA/GM			
CHECKED BY : GM 5/06	REV. 7/12	MAA/GM			
	REV. 6/13	MAA/GM			

SUPERSTRUCTURE REINFORCING STEEL LENGTHS ARE BASED ON THE FOLLOWING MINIMUM SPLICE LENGTHS

BAR SIZE	SUPERSTRUCTURE EXCEPT APPROACH SLABS, PARAPET AND BARRIER RAIL		APPROACH SLABS		PARAPET AND BARRIER RAIL
	EPOXY COATED	UNCOATED	EPOXY COATED	UNCOATED	
#4	2'-0"	1'-9"	2'-0"	1'-9"	2'-9"
#5	2'-6"	2'-2"	2'-6"	2'-2"	3'-5"
#6	3'-0"	2'-7"	3'-10"	2'-7"	4'-4"
#7	5'-3"	3'-6"			
#8	6'-10"	4'-7"			

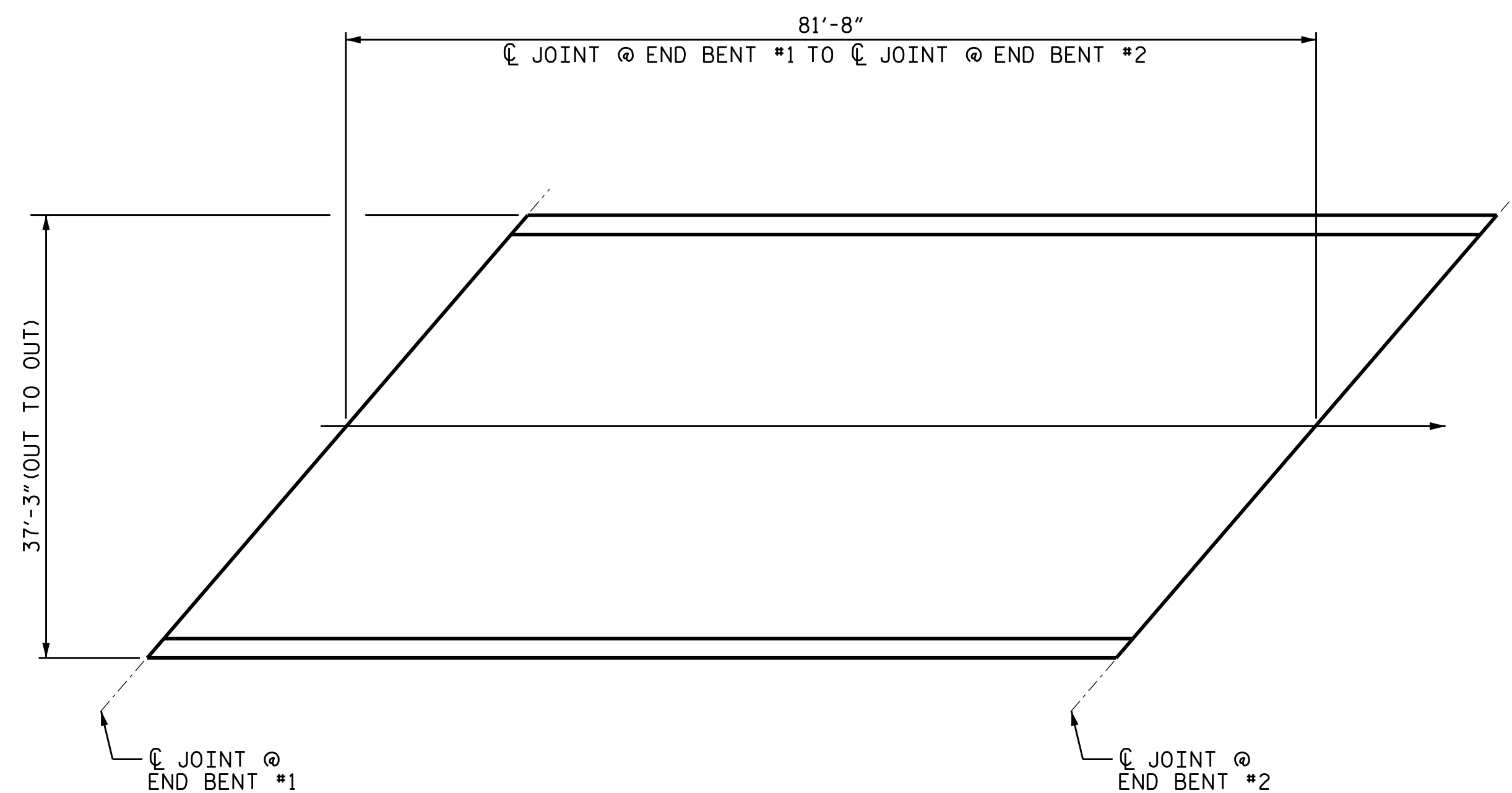

LAYOUT FOR COMPUTING AREA REINFORCED CONCRETE DECK SLAB (SQ. FT. = 3,042)

BILL OF MATERIAL

BAR	NO.	SIZE	TYPE	LENGTH	WEIGHT	BAR	NO.	SIZE	TYPE	LENGTH	WEIGHT
* A1	98	#5	STR	37'-0"	3,782	A205	4	#5	STR	31'-8"	66
A2	98	#5	STR	37'-0"	3,782	A206	4	#5	STR	30'-6"	64
* A3	6	#6	STR	7'-10"	71	A207	4	#5	STR	29'-4"	61
						A208	4	#5	STR	28'-2"	59
* A101	4	#5	STR	36'-4"	76	A209	4	#5	STR	27'-0"	56
* A102	4	#5	STR	35'-2"	73	A210	4	#5	STR	25'-10"	54
* A103	4	#5	STR	34'-0"	71	A211	4	#5	STR	24'-8"	51
* A104	4	#5	STR	32'-10"	68	A212	4	#5	STR	23'-6"	49
* A105	4	#5	STR	31'-8"	66	A213	4	#5	STR	22'-4"	47
* A106	4	#5	STR	30'-6"	64	A214	4	#5	STR	21'-2"	44
* A107	4	#5	STR	29'-4"	61	A215	4	#5	STR	20'-1"	42
* A108	4	#5	STR	28'-2"	59	A216	4	#5	STR	18'-11"	39
* A109	4	#5	STR	27'-0"	56	A217	4	#5	STR	17'-9"	37
* A110	4	#5	STR	25'-10"	54	A218	4	#5	STR	16'-7"	35
* A111	4	#5	STR	24'-8"	51	A219	4	#5	STR	15'-5"	32
* A112	4	#5	STR	23'-6"	49	A220	4	#5	STR	14'-3"	30
* A113	4	#5	STR	22'-4"	47	A221	4	#5	STR	13'-1"	27
* A114	4	#5	STR	21'-2"	44	A222	4	#5	STR	11'-11"	25
* A115	4	#5	STR	20'-1"	42	A223	4	#5	STR	10'-9"	22
* A116	4	#5	STR	18'-11"	39	A224	4	#5	STR	9'-7"	20
* A117	4	#5	STR	17'-9"	37	A225	4	#5	STR	8'-5"	18
* A118	4	#5	STR	16'-7"	35	A226	4	#5	STR	7'-3"	15
* A119	4	#5	STR	15'-5"	32	A227	4	#5	STR	6'-1"	13
* A120	4	#5	STR	14'-3"	30	A228	4	#5	STR	4'-11"	10
* A121	4	#5	STR	13'-1"	27	A229	4	#5	STR	3'-9"	8
* A122	4	#5	STR	11'-11"	25	A230	4	#5	STR	2'-7"	5
* A123	4	#5	STR	10'-9"	22						
* A124	4	#5	STR	9'-7"	20	B1	75	#4	STR	28'-5"	1,424
* A125	4	#5	STR	8'-5"	18	B2	104	#5	STR	41'-9"	4,529
* A126	4	#5	STR	7'-3"	15						
* A127	4	#5	STR	6'-1"	13	* K1	8	#8	1	14'-11"	119
* A128	4	#5	STR	4'-11"	10	* K2	12	#8	2	21'-3"	255
* A129	4	#5	STR	3'-9"	8	K3	24	#6	STR	7'-10"	188
* A130	4	#5	STR	2'-7"	5	* S1	64	#4	4	5'-0"	320
						S2	64	#5	3	5'-0"	320
A201	4	#5	STR	36'-4"	76						
A202	4	#5	STR	35'-2"	73	* J1	88	#4	STR	1'-5"	83
A203	4	#5	STR	34'-0"	71	G	2	#5	5	48'-9"	102
A204	4	#5	STR	32'-10"	68						

* EPOXY COATED REINFORCING STEEL

GROOVING BRIDGE FLOORS	
APPROACH SLABS	1,700 SQ.FT.
BRIDGE DECK	2,773 SQ.FT.
TOTAL	4,473 SQ.FT.

** QUANTITIES FOR BARRIER RAIL ARE NOT INCLUDED

PROJECT NO. U-4405
CUMBERLAND COUNTY
 STATION: 26+78.00 -RPB-

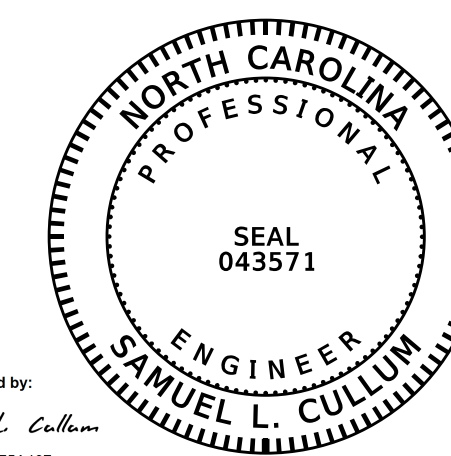

6/6/2018 12:30:46 PM PDT

DOCUMENT NOT CONSIDERED FINAL UNLESS ALL SIGNATURES COMPLETED

STATE OF NORTH CAROLINA DEPARTMENT OF TRANSPORTATION RALEIGH					
STANDARD SUPERSTRUCTURE BILL OF MATERIAL					
REVISIONS					
NO.	BY:	DATE:	NO.	BY:	DATE:
1			3		
2			4		

SHEET NO.	S-16
TOTAL SHEETS	26

KCA KISINGER CAMPO & ASSOCIATES	4800 SIX FORKS ROAD SUITE 120 RALEIGH, NC 27609 (919) 882-7839
ASSEMBLED BY : S. BOYD CHECKED BY : L. MARTINEZ	DATE : 05-17 DATE : 05-17
DRAWN BY : JMB 5/87 CHECKED BY : SJD 9/87	REV. 8/16/99 RWW/LES REV. 5/1/06 TLA/GM REV. 10/1/11 MAA/GM

NOTES

STIRRUPS IN CAP MAY BE SHIFTED AS NECESSARY TO CLEAR ANCHOR BOLTS.

BACKWALL SHALL BE PLACED BEFORE APPLYING THE EPOXY PROTECTIVE COATING.

THE TOP SURFACE AREAS OF THE END BENT CAP SHALL BE CURED IN ACCORDANCE WITH THE STANDARD SPECIFICATIONS EXCEPT THE MEMBRANE CURING COMPOUND METHOD SHALL NOT BE USED.

THE TOP SURFACE OF THE CAP EXCEPT THE BRIDGE SEAT BUILDUPS SHALL BE SLOPED TRANSVERSELY FROM THE FILL FACE TO THE BACK FACE AT THE RATE OF 2%.

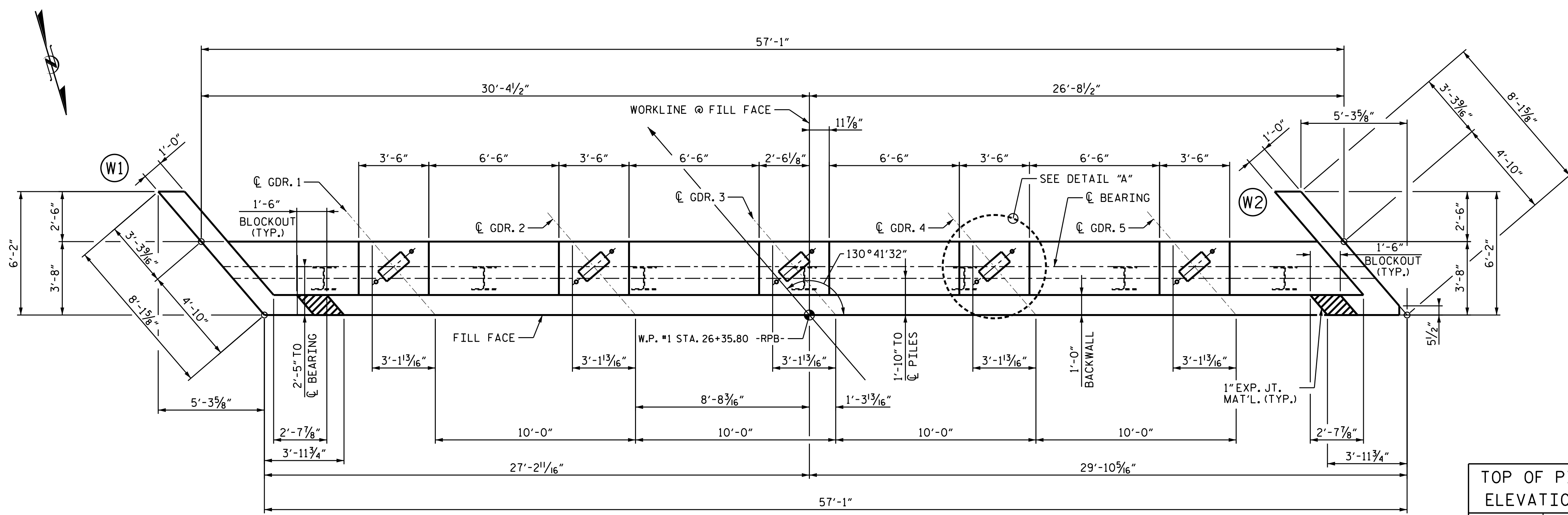

TOP OF PILE ELEVATIONS

PILE No.	EL.
P1 - P7	228.16

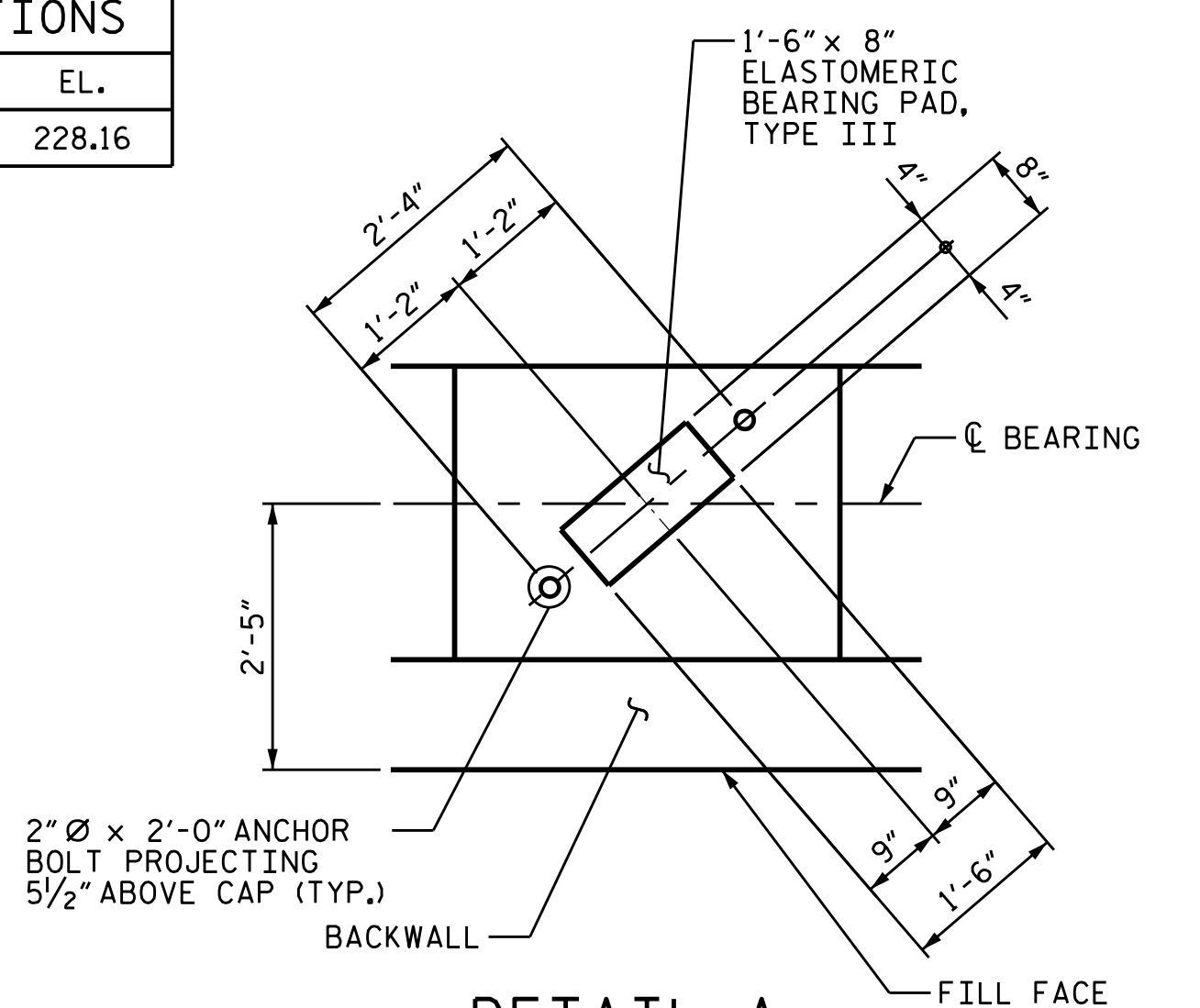
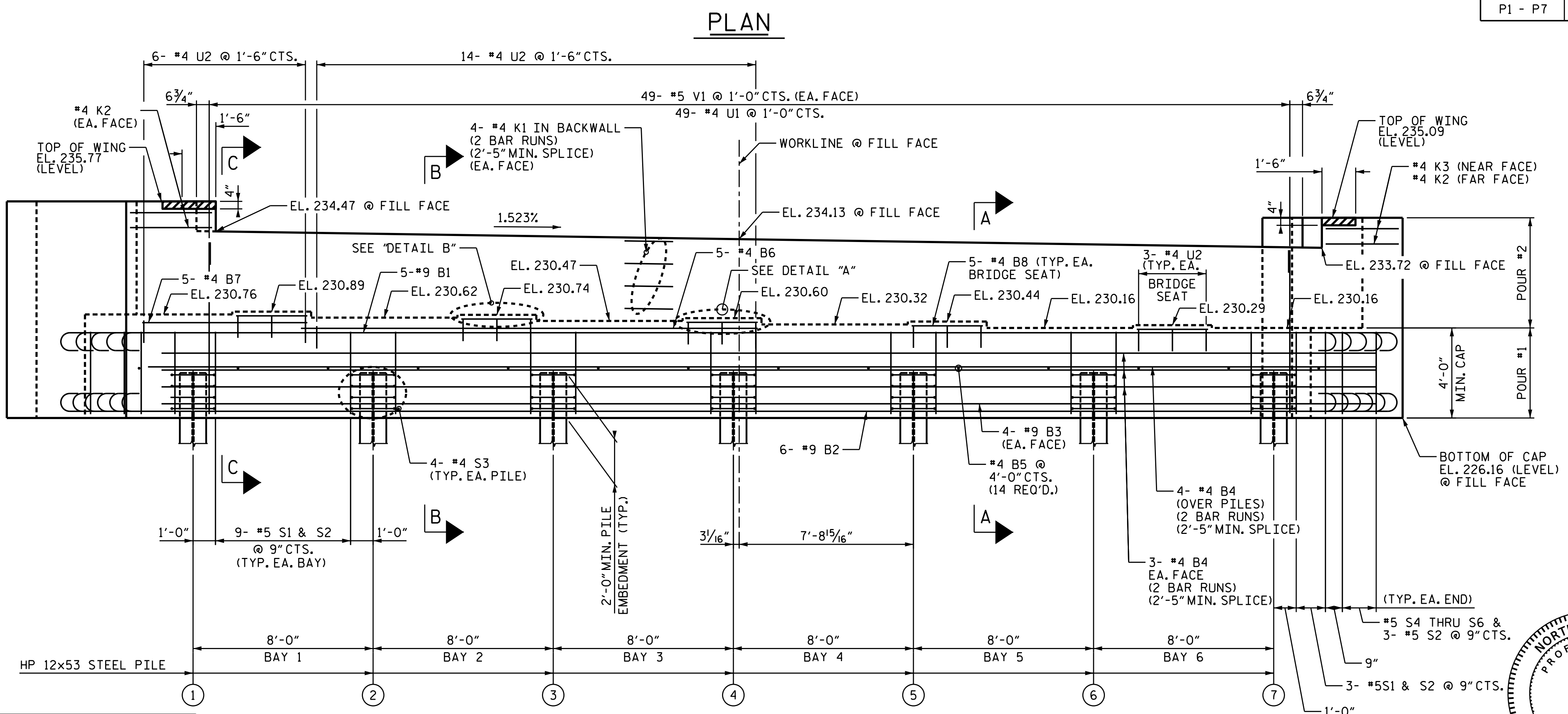
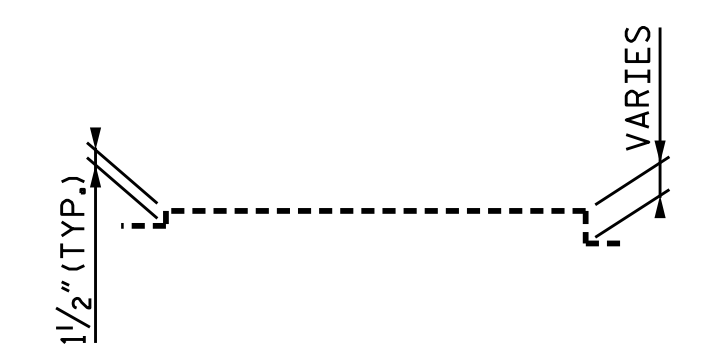

PROJECT NO. U-4405
CUMBERLAND COUNTY
 STATION: 26+78.00 -RPB-

SHEET 1 OF 3

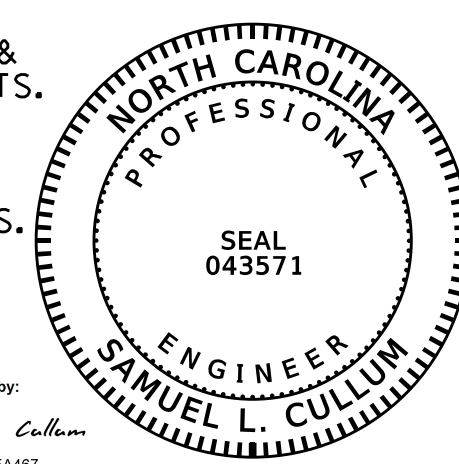

STATE OF NORTH CAROLINA
 DEPARTMENT OF TRANSPORTATION
 RALEIGH

**SUBSTRUCTURE
 END BENT #1**

KCA 4800 SIX FORKS ROAD SUITE 120
 KISINGER CAMPO & ASSOCIATES RALEIGH, NC 27609
 (919) 882-7839

DRAWN BY: J. B. HANNA DATE: 05-17
 CHECKED BY: S. BOYD DATE: 05-17
 DESIGN ENGINEER OF RECORD: S. CULLUM DATE: 05-17

6/6/2018 12:30:46 PM PDT

DOCUMENT NOT CONSIDERED FINAL UNLESS ALL SIGNATURES COMPLETED

REVISIONS						SHEET NO.
NO.	BY:	DATE:	NO.	BY:	DATE:	S-17
1			3			TOTAL SHEETS
2			4			26

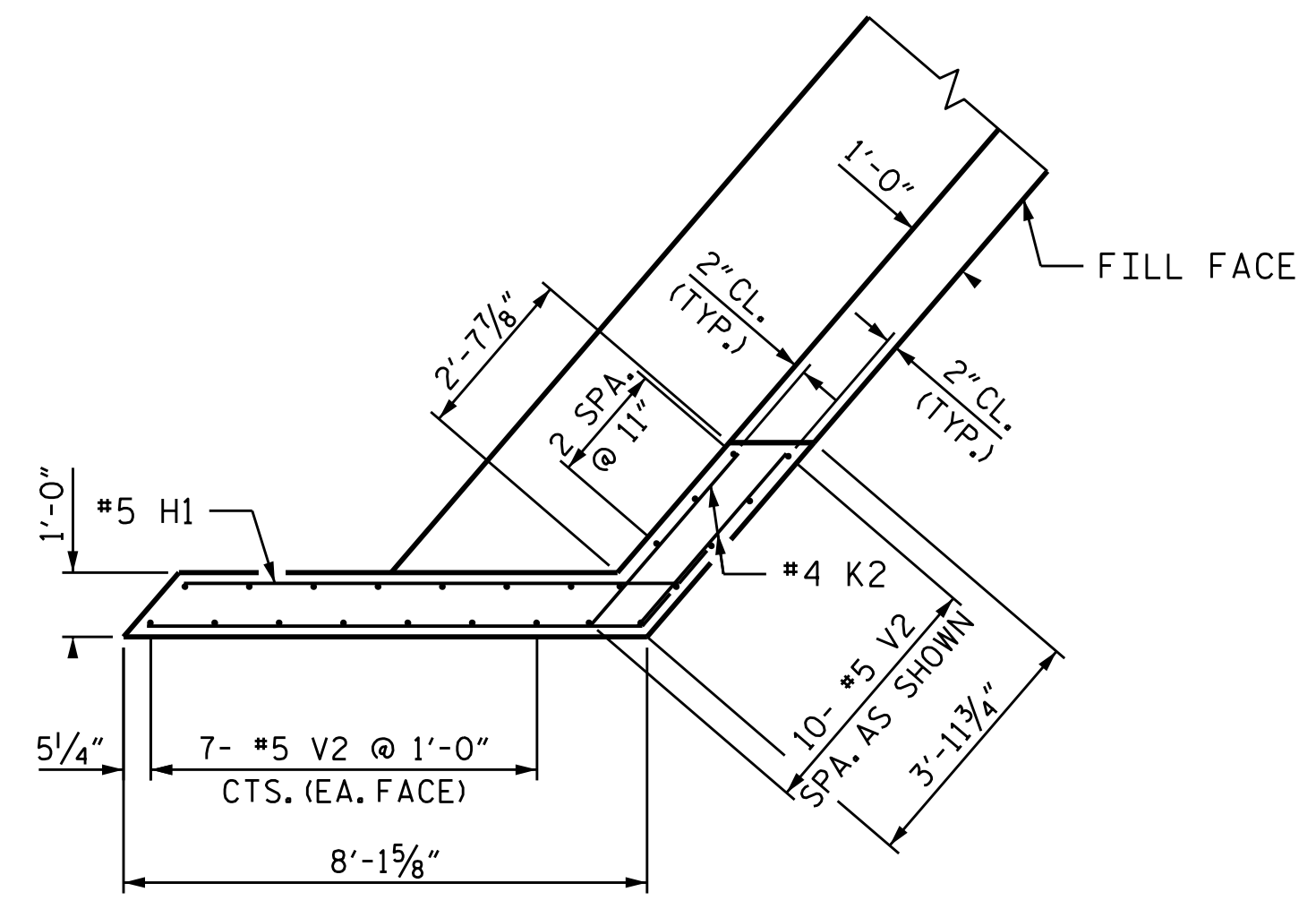

PLAN OF WING W1

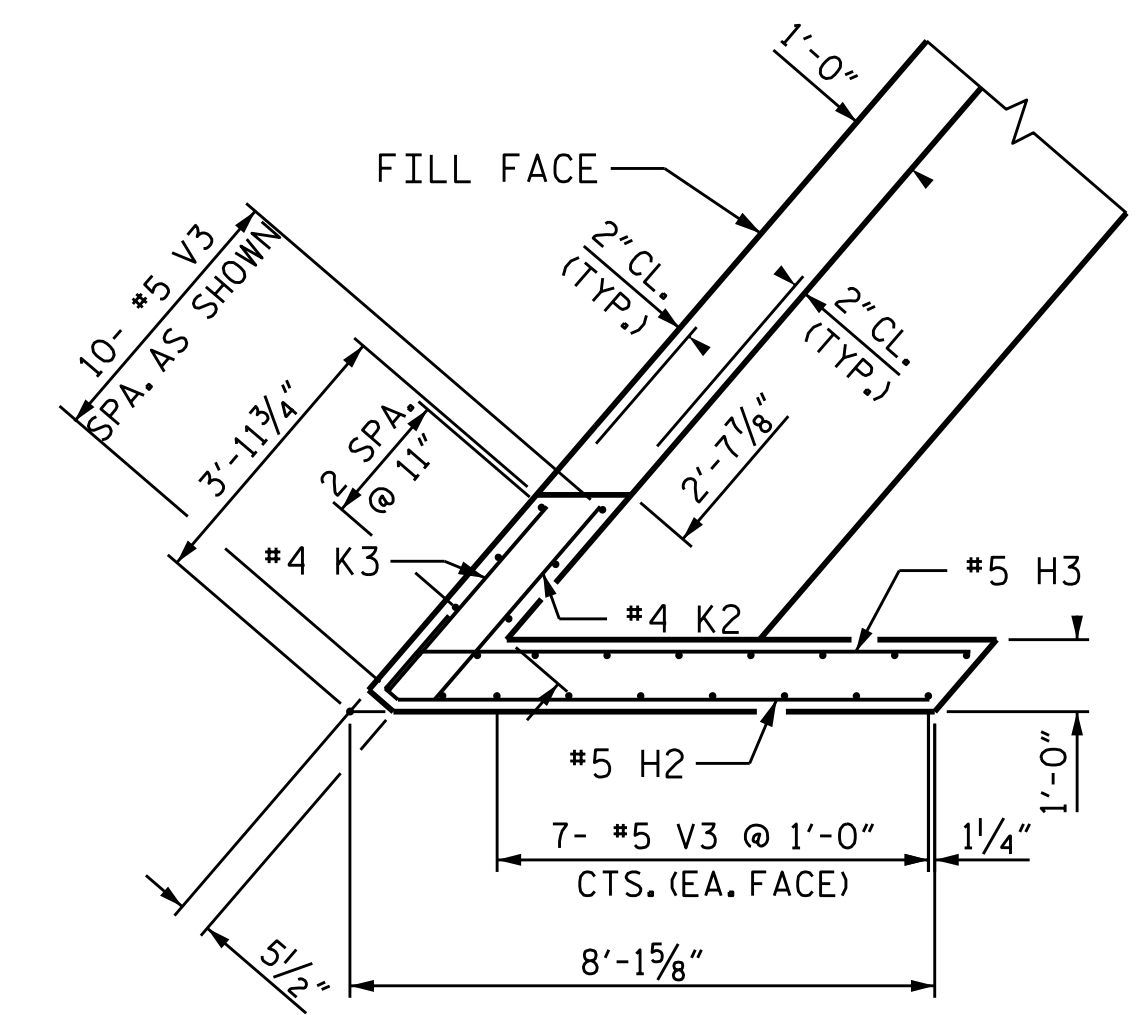

PLAN OF WING W2

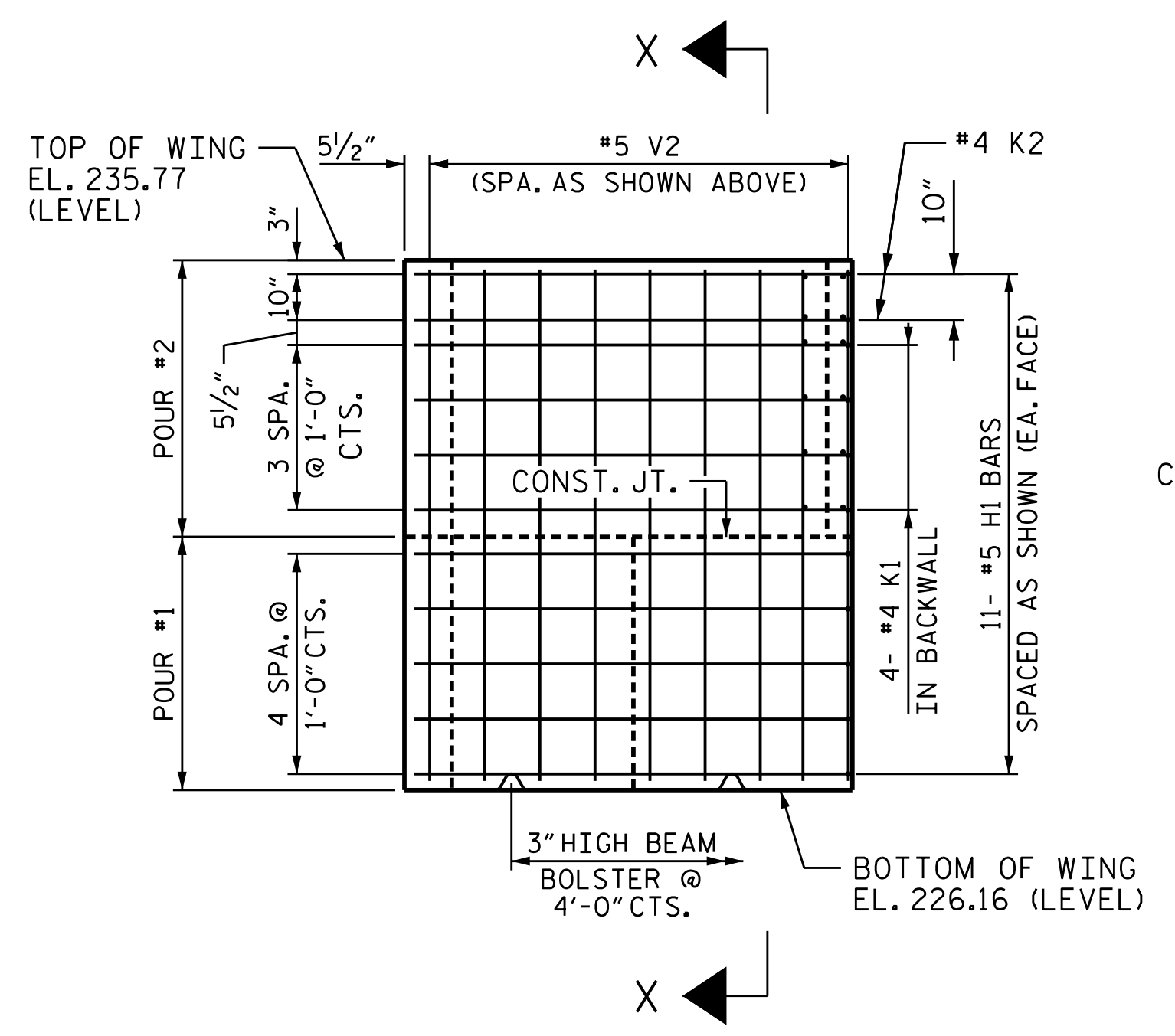

ELEVATION OF WING W1

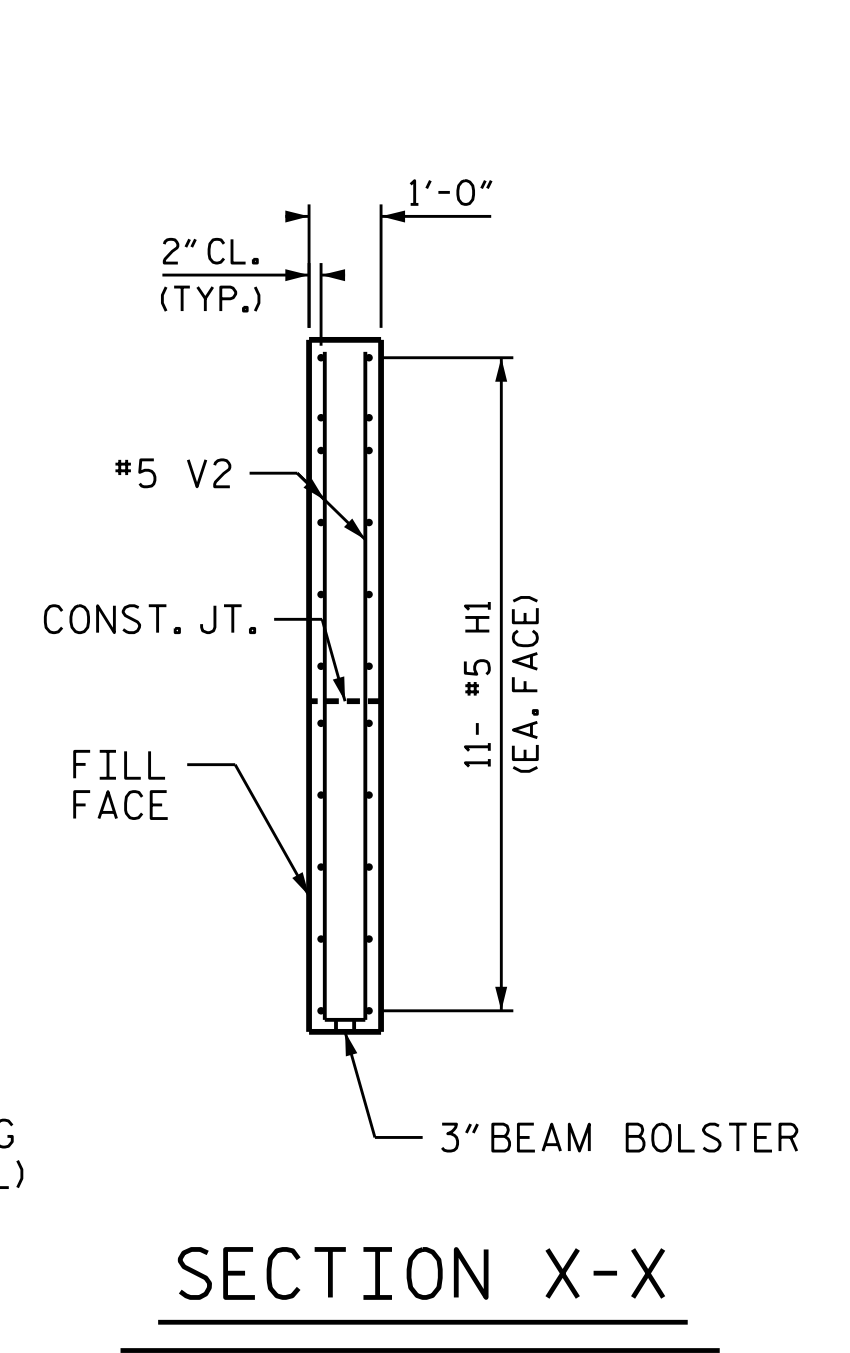

SECTION X-X

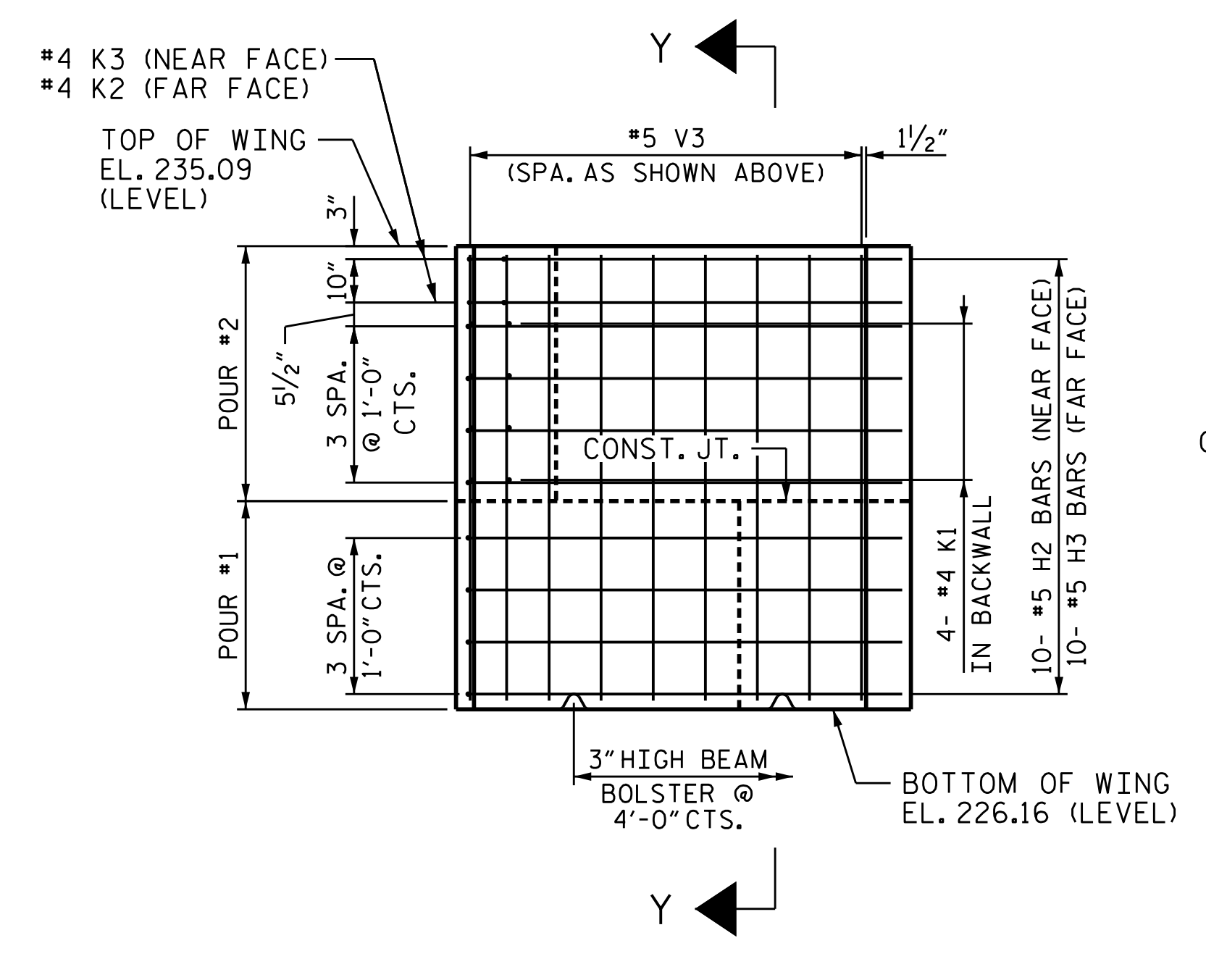

ELEVATION OF WING W2

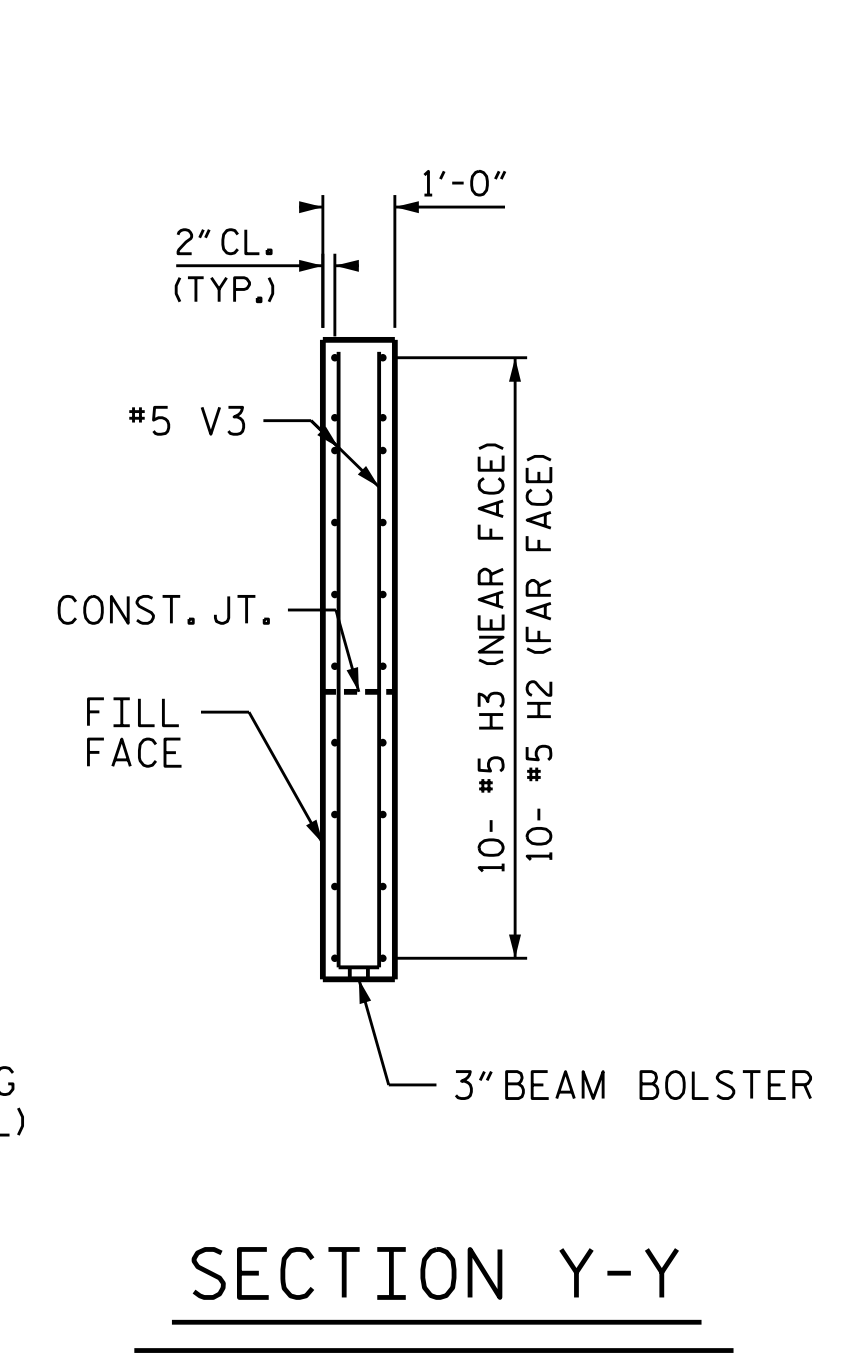

SECTION Y-Y

PROJECT NO. U-4405
 CUMBERLAND COUNTY
 STATION: 26+78.00 -RPB-

SHEET 2 OF 3

STATE OF NORTH CAROLINA
 DEPARTMENT OF TRANSPORTATION
 RALEIGH

SUBSTRUCTURE
 END BENT #1

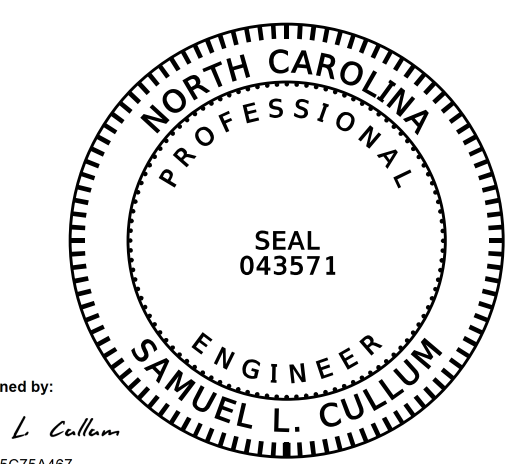

6/6/2018 12:30:46 PM PDT

KCA 4800 SIX FORKS ROAD SUITE 120
 KISINGER CAMPO & ASSOCIATES RALEIGH, NC 27609
 (919) 882-7839

DRAWN BY: J. B. HANNA DATE: 05-17
 CHECKED BY: S. BOYD DATE: 05-17
 DESIGN ENGINEER OF RECORD: S. CULLUM DATE: 05-17

REVISIONS						SHEET NO.
NO.	BY:	DATE:	NO.	BY:	DATE:	S-18
1			3			TOTAL SHEETS
2			4			26

DOCUMENT NOT CONSIDERED FINAL UNLESS ALL SIGNATURES COMPLETED

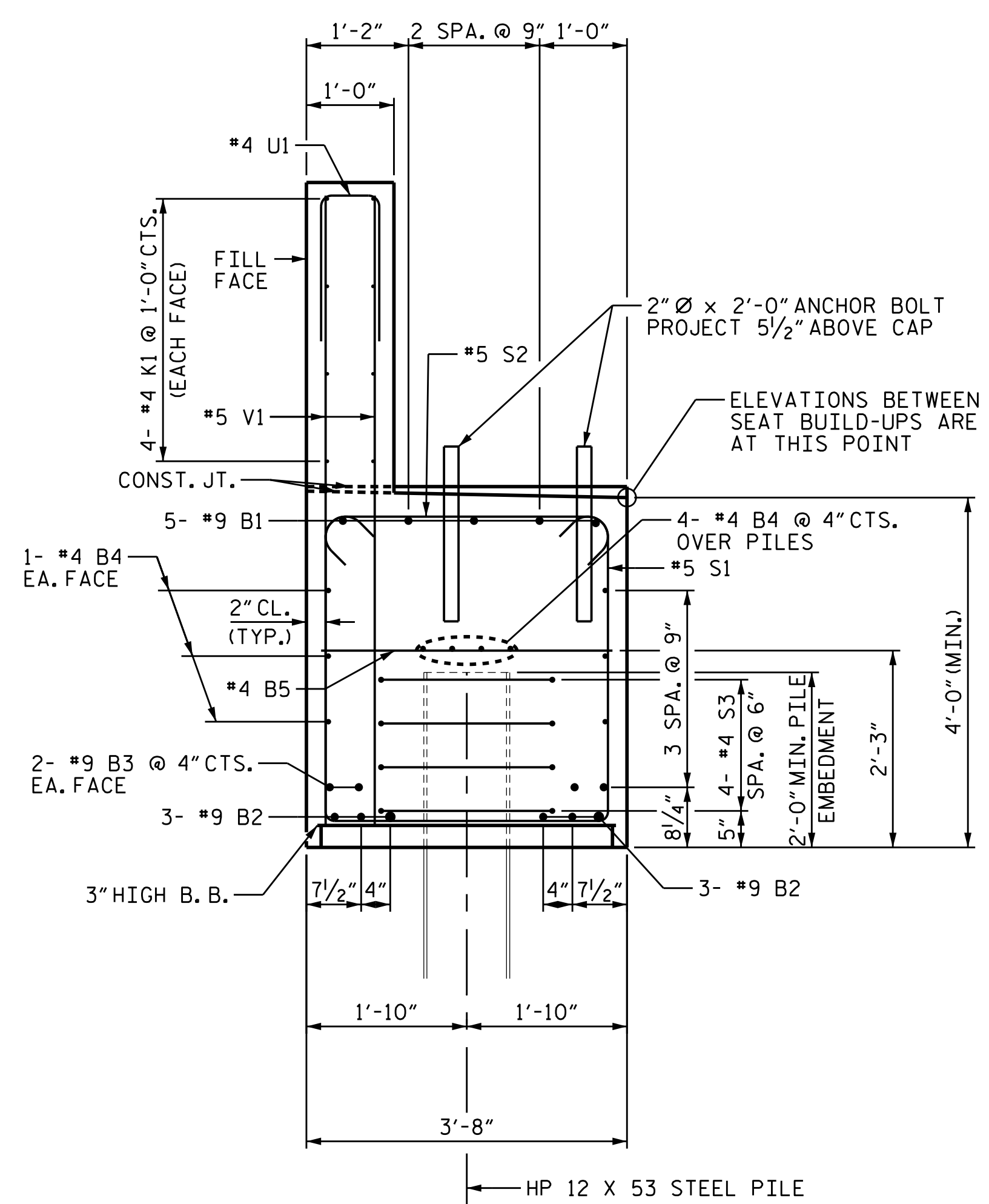

SECTION A-A

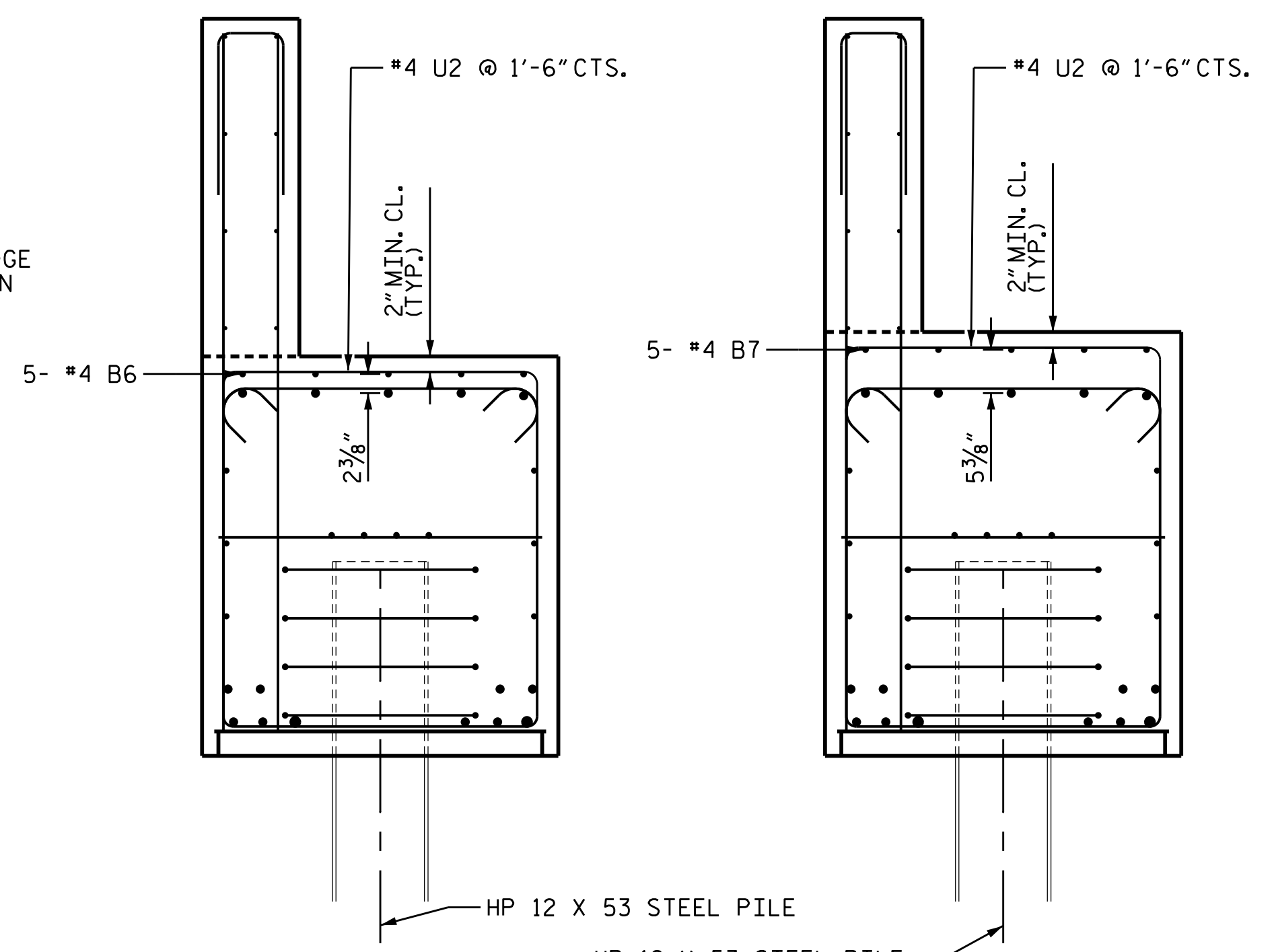

SECTION B-B

SECTION C-C

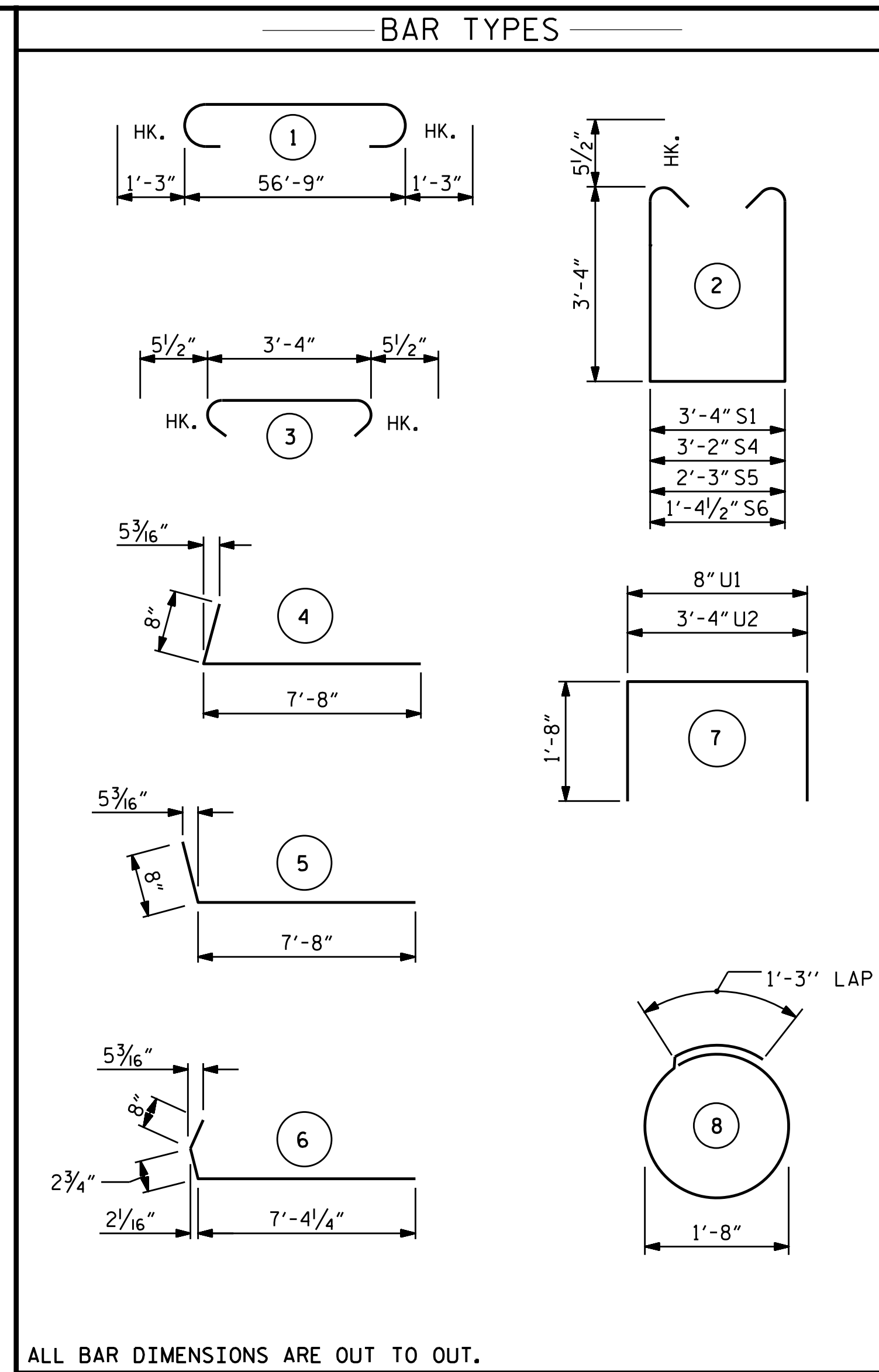

ALL BAR DIMENSIONS ARE OUT TO OUT.

BILL OF MATERIAL					
END BENT #1					
BAR	NO.	SIZE	TYPE	LENGTH	WEIGHT
B1	5	9	1	59'-3"	1007
B2	6	9	1	59'-3"	1209
B3	4	9	STR	56'-9"	772
B4	14	4	STR	29'-7"	277
B5	14	4	STR	3'-4"	31
B6	5	4	STR	21'-0"	70
B7	5	4	STR	8'-2"	27
B8	25	4	STR	3'-2"	53
H1	22	5	5	8'-4"	191
H2	10	5	6	8'-3"	86
H3	10	5	4	8'-4"	87
K1	8	4	STR	29'-7"	158
K2	6	4	STR	3'-6"	14
K3	2	4	STR	3'-4"	4
S1	60	5	2	7'-11"	495
S2	66	5	3	4'-3"	293
S3	28	5	8	6'-6"	190
S4	2	5	2	7'-9"	16
S5	2	5	2	6'-10"	14
S6	2	5	2	5'-11 1/2"	12
U1	49	4	7	4'-0"	131
U2	35	4	7	6'-8"	156
V1	98	5	STR	7'-2"	733
V2	24	5	STR	9'-2"	229
V3	24	5	STR	8'-6"	213
REINFORCING STEEL				LBS.	6468
CLASS "A" CONCRETE BREAKDOWN					
POUR #1 CAP AND LOWER WINGS				34.6	C.Y.
POUR #2 BACKWALL & UPPER WINGS				10.6	C.Y.
TOTAL				45.2	C.Y.
HP 12 x 53 STEEL PILES				No. = 7	LIN. FEET. 630
PILE REDRIVES					EA. 4

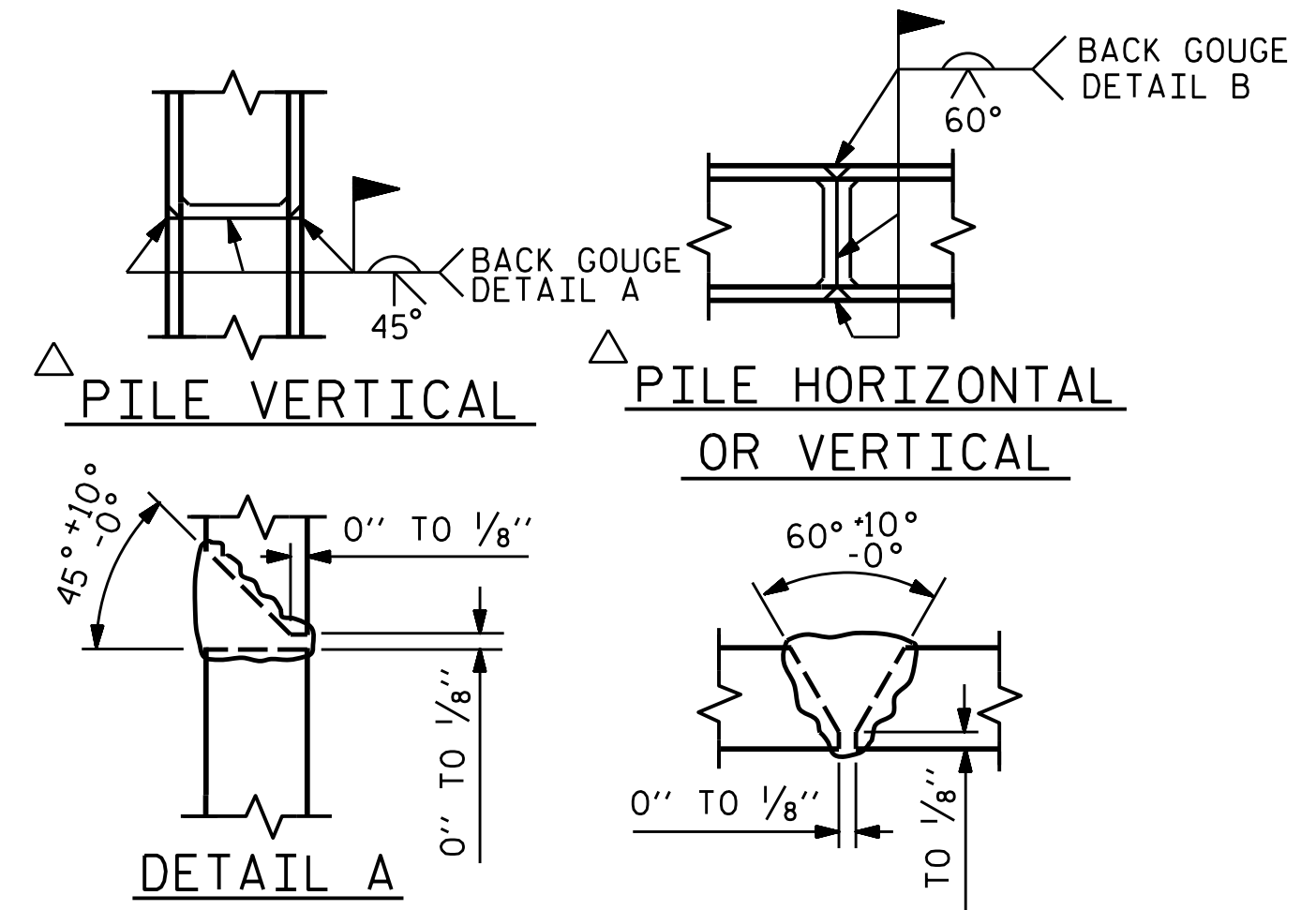

PILE SPLICE DETAILS

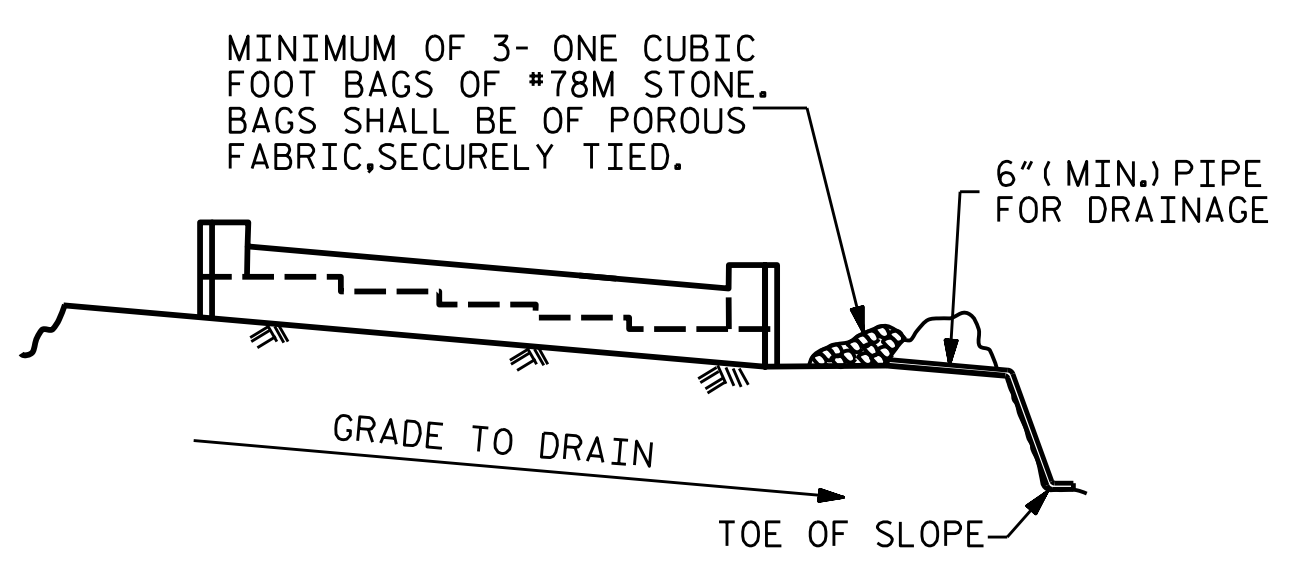

BAGGED STONE AND PIPE SHALL BE PLACED IMMEDIATELY AFTER COMPLETION OF END BENT EXCAVATION. PIPE MAY BE EITHER CONCRETE, CORRUGATED STEEL, CORRUGATED ALUMINUM ALLOY, OR CORRUGATED PLASTIC. PERFORATED PIPE WILL NOT BE ALLOWED.

BAGGED STONE SHALL REMAIN IN PLACE UNTIL THE ENGINEER DIRECTS THAT IT BE REMOVED. THE CONTRACTOR SHALL REMOVE AND DISPOSE OF SILT ACCUMULATIONS AT BAGGED STONE WHEN SO DIRECTED BY THE ENGINEER. BAGS SHALL BE REMOVED AND REPLACED WHENEVER THE ENGINEER DETERMINES THAT THEY HAVE DETERIORATED AND LOST THEIR EFFECTIVENESS.

NO SEPARATE PAYMENT WILL BE MADE FOR THIS WORK AND THE ENTIRE COST OF THIS WORK SHALL BE INCLUDED IN THE UNIT CONTRACT PRICE BID FOR THE SEVERAL PAY ITEMS.

TEMPORARY DRAINAGE AT END BENT

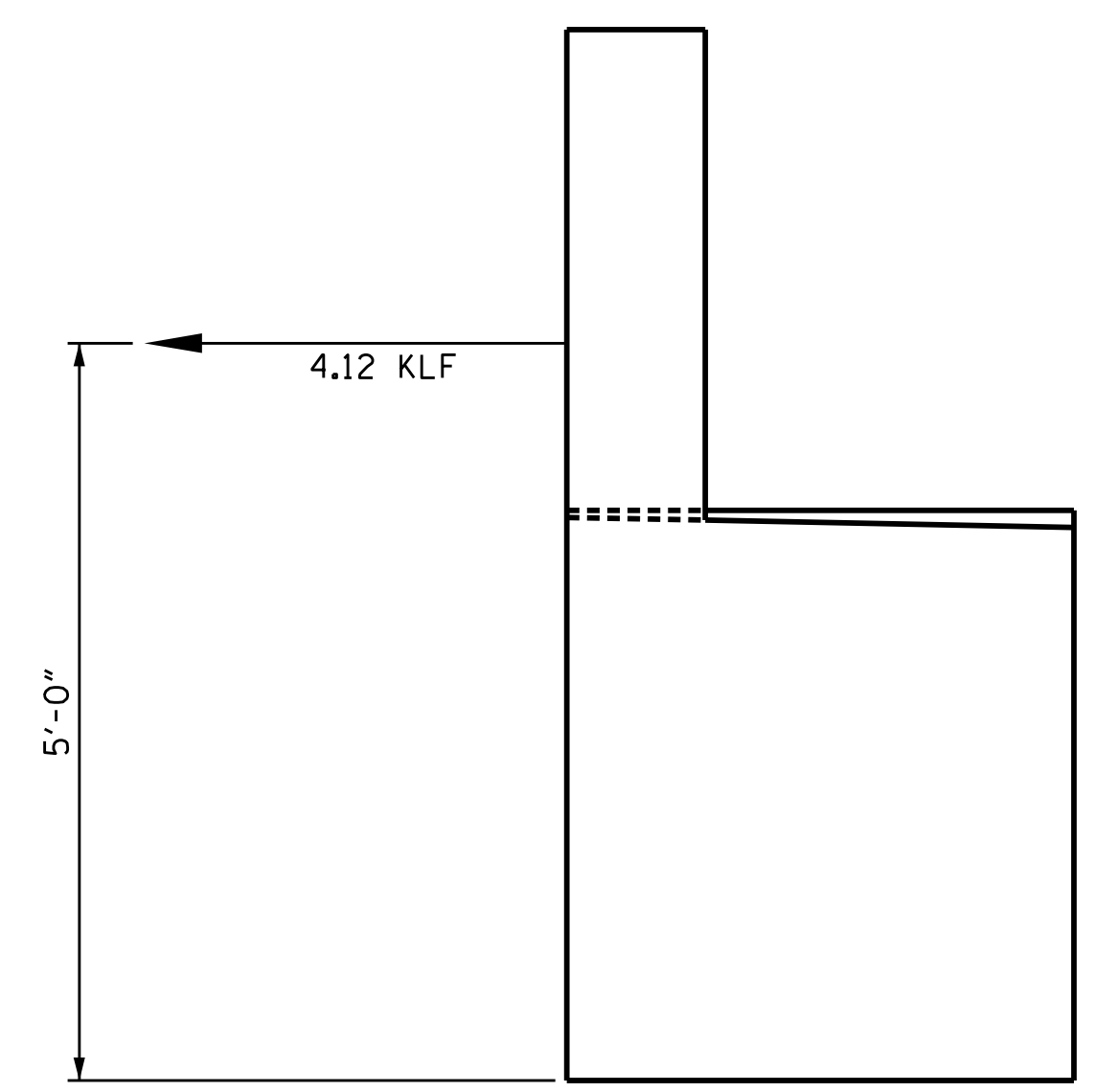

STRAP LOAD DETAIL

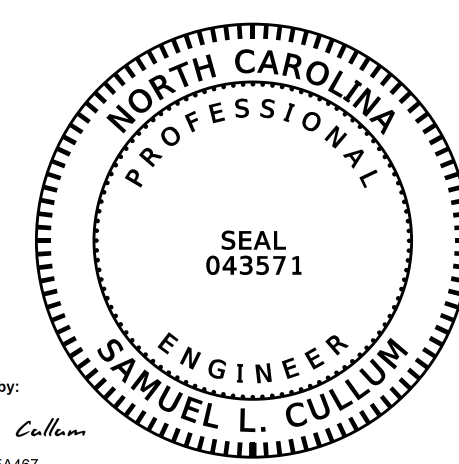

PROJECT NO. U-4405
 CUMBERLAND COUNTY
 STATION: 26+78.00 -RPB-

SHEET 3 OF 3

STATE OF NORTH CAROLINA
 DEPARTMENT OF TRANSPORTATION
 RALEIGH
 SUBSTRUCTURE
 END BENT #1

REVISIONS						SHEET NO.
NO.	BY:	DATE:	NO.	BY:	DATE:	S-19
1			3			TOTAL SHEETS
2			4			26

KCA 4800 SIX FORKS ROAD SUITE 120
 KISINGER CAMPO & ASSOCIATES RALEIGH, NC 27609
 (919) 882-7839

DRAWN BY: J. B. HANNA DATE: 05-17
 CHECKED BY: L. MARTINEZ DATE: 05-17
 DESIGN ENGINEER OF RECORD: S. CULLUM DATE: 05-17

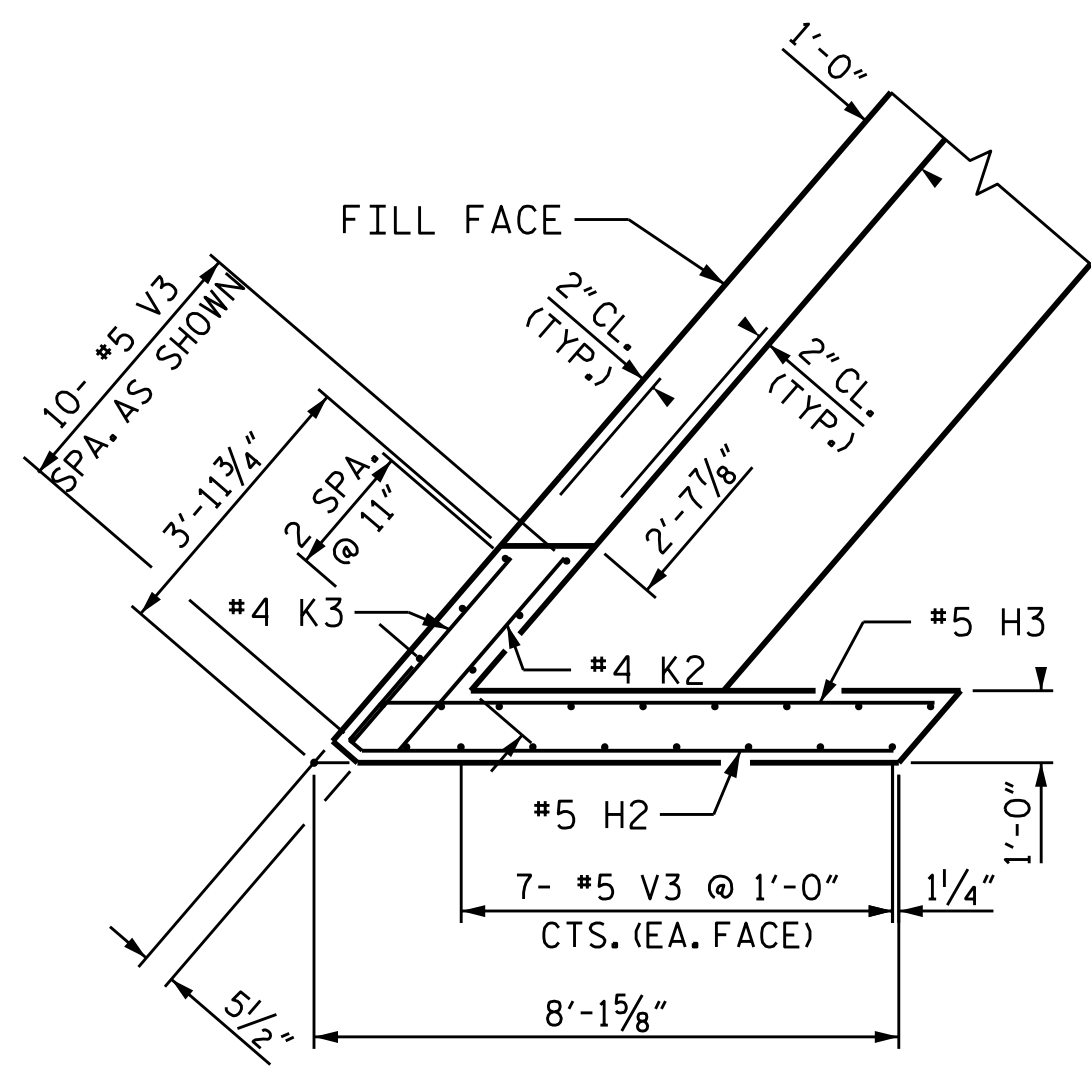

PLAN OF WING W1

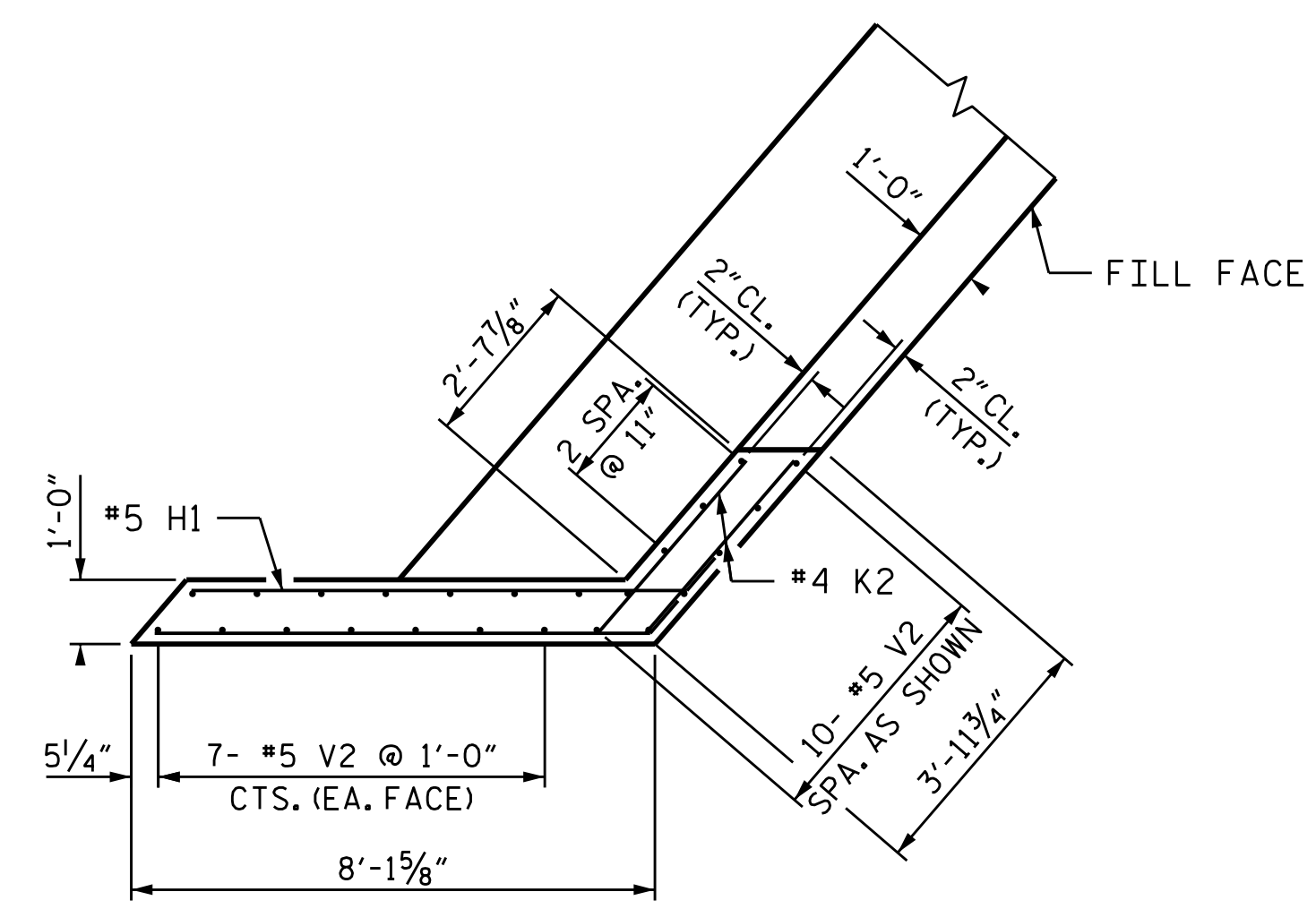

PLAN OF WING W2

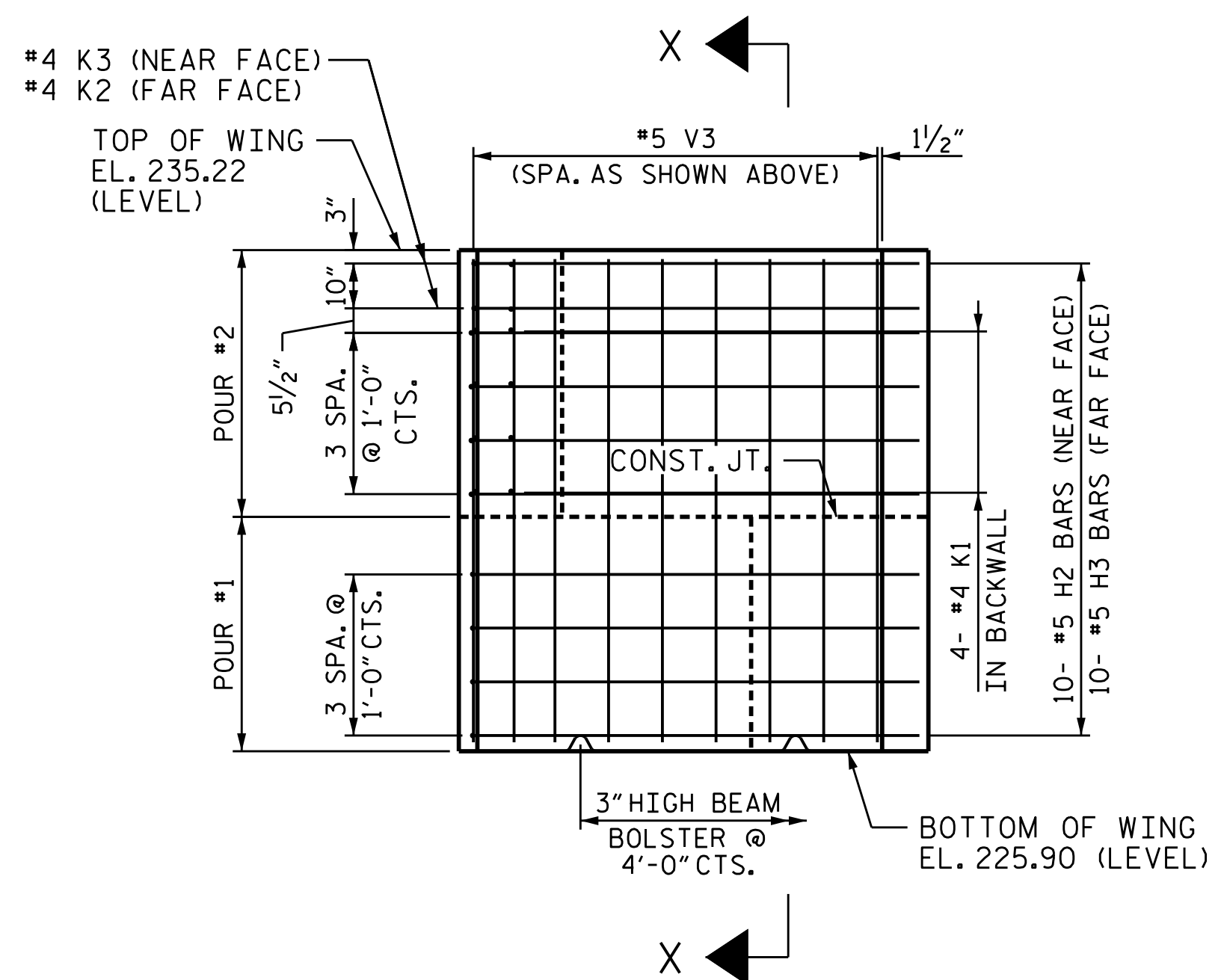

ELEVATION OF WING W1

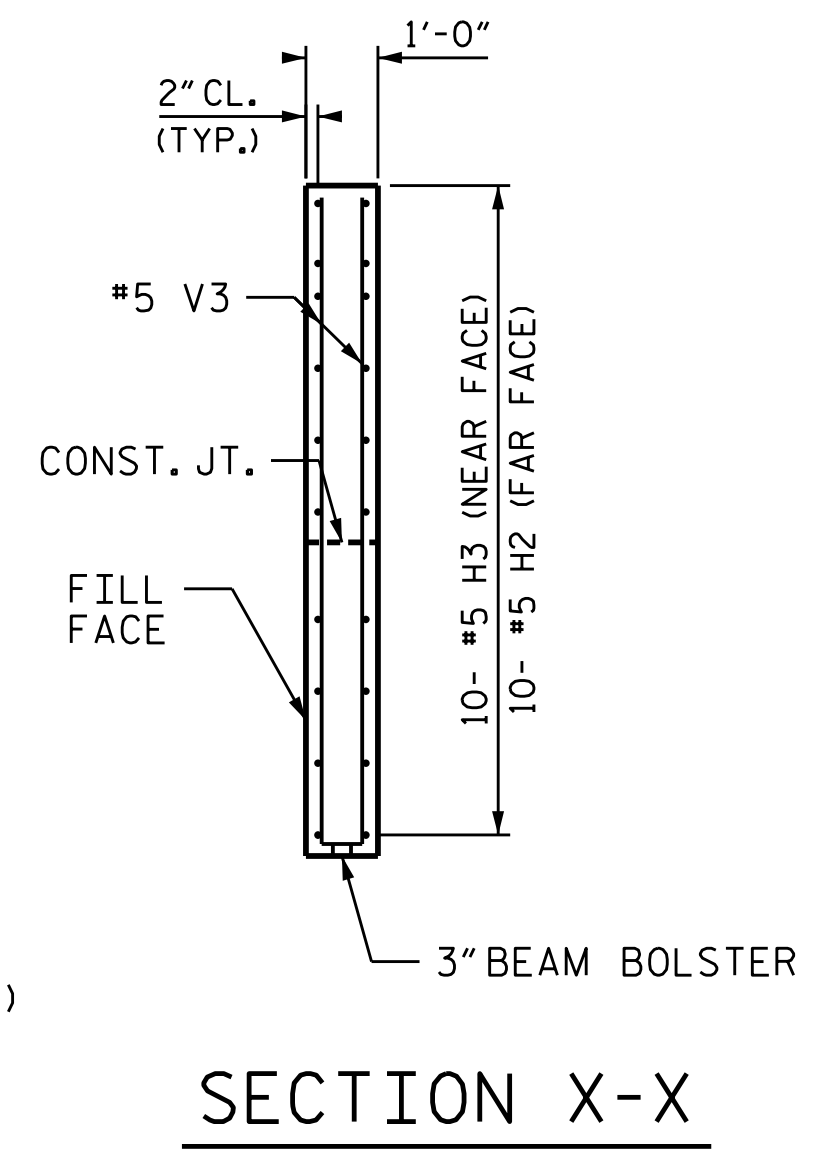

SECTION X-X

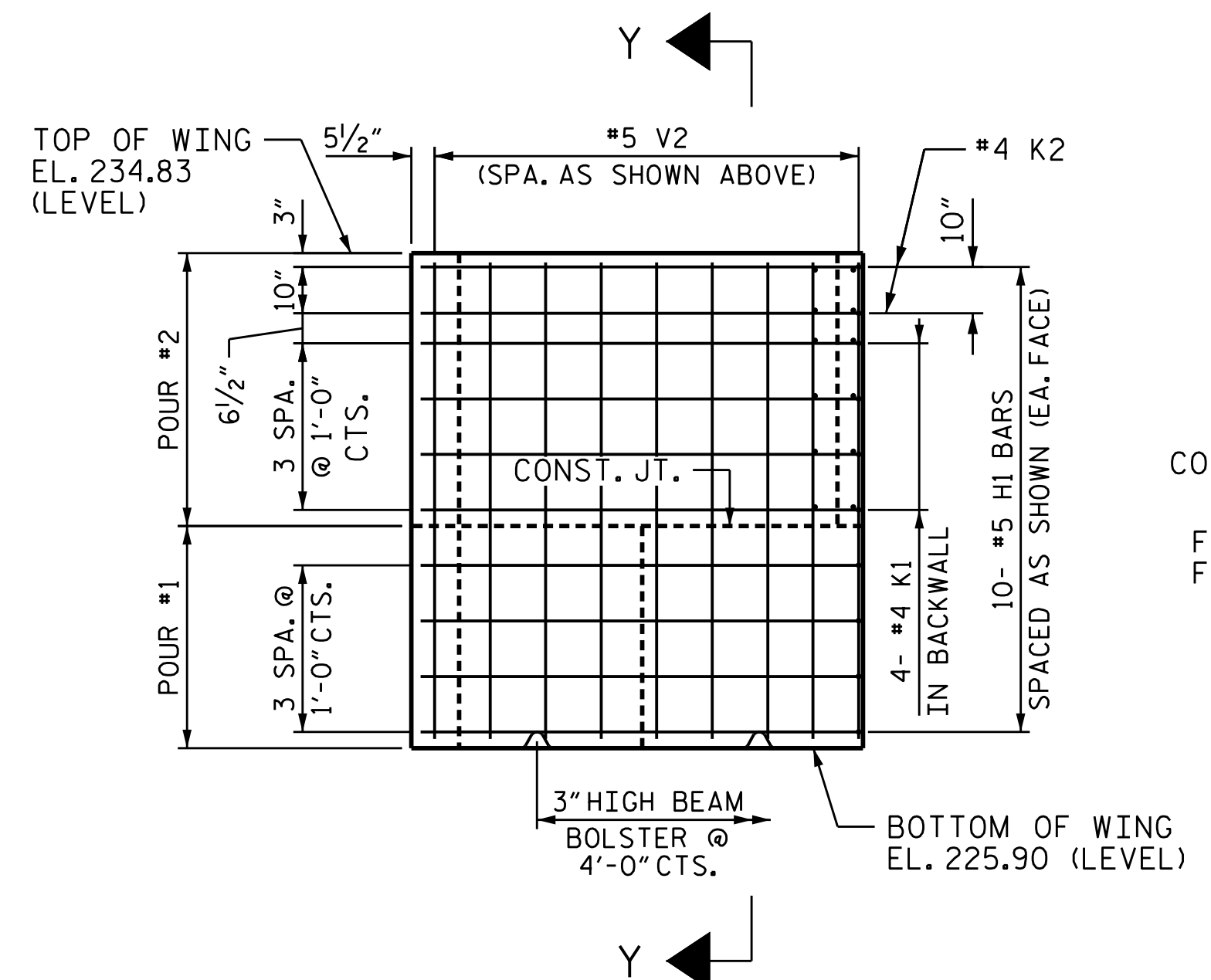

ELEVATION OF WING W2

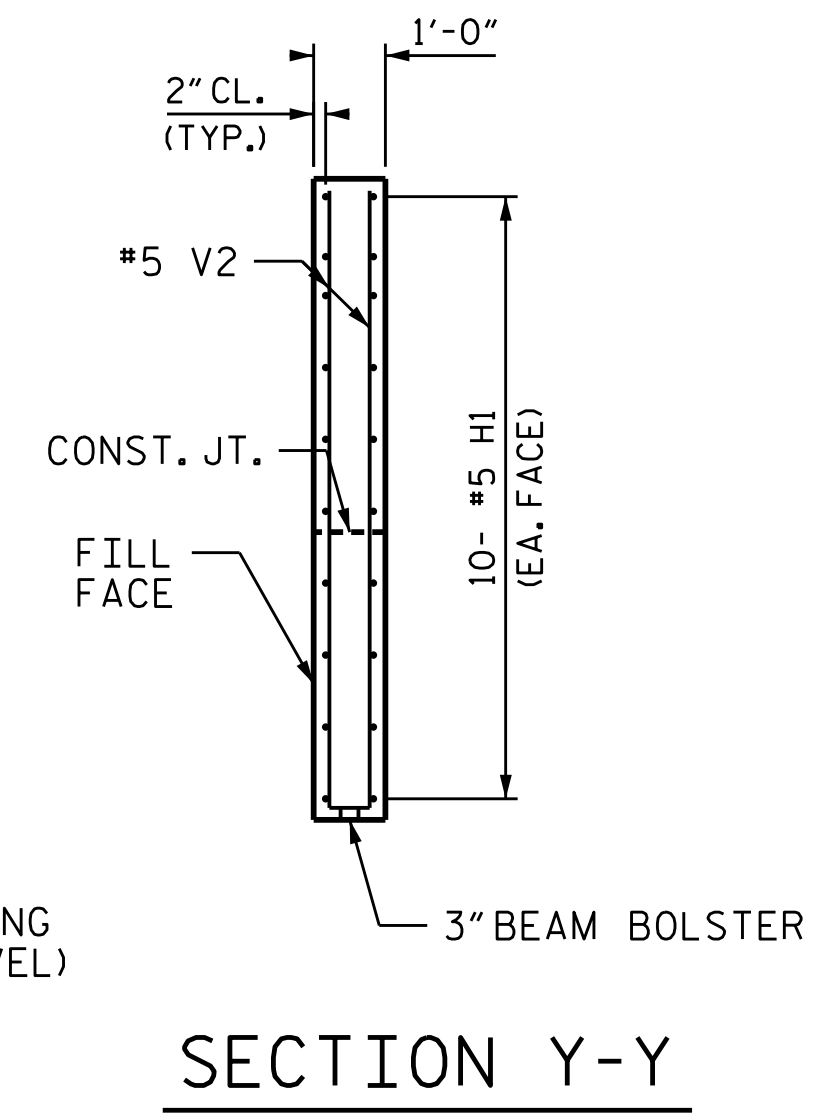

SECTION Y-Y

PROJECT NO. U-4405
 CUMBERLAND COUNTY
 STATION: 26+78.00 -RPB-

SHEET 2 OF 3

STATE OF NORTH CAROLINA
 DEPARTMENT OF TRANSPORTATION
 RALEIGH

SUBSTRUCTURE
 END BENT #2

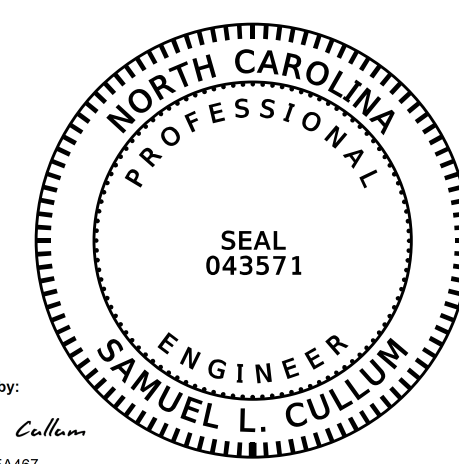

6/6/2018 12:30:46 PM PDT

KCA 4800 SIX FORKS ROAD SUITE 120
 KISINGER CAMPO & ASSOCIATES RALEIGH, NC 27609
 (919) 882-7839

DRAWN BY: J. B. HANNA DATE: 05-17
 CHECKED BY: S. BOYD DATE: 05-17
 DESIGN ENGINEER OF RECORD: S. CULLUM DATE: 05-17

REVISIONS						SHEET NO.
NO.	BY:	DATE:	NO.	BY:	DATE:	S-21
1			3			TOTAL SHEETS
2			4			26

DOCUMENT NOT CONSIDERED FINAL UNLESS ALL SIGNATURES COMPLETED

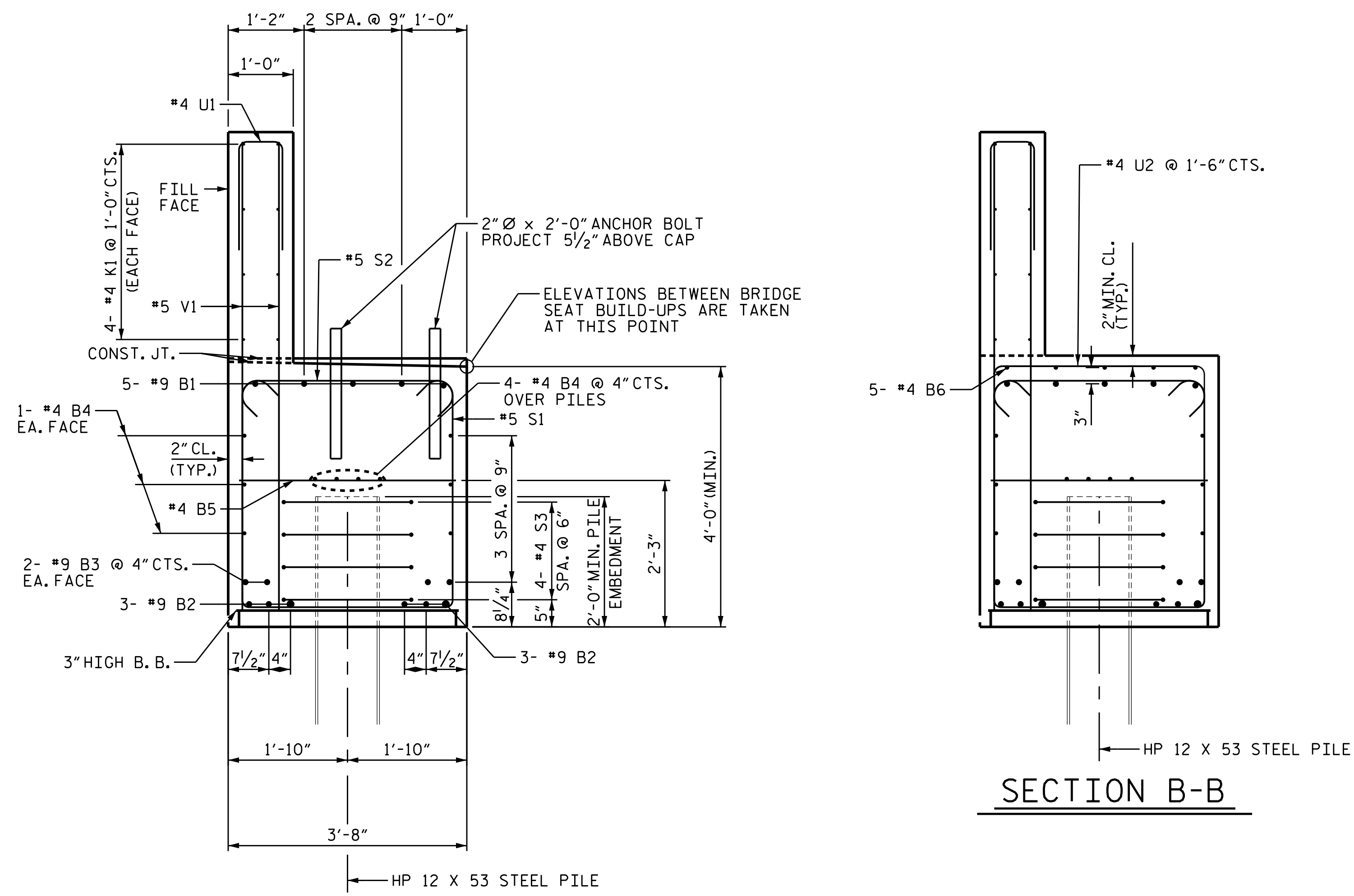

SECTION A-A

SECTION B-B

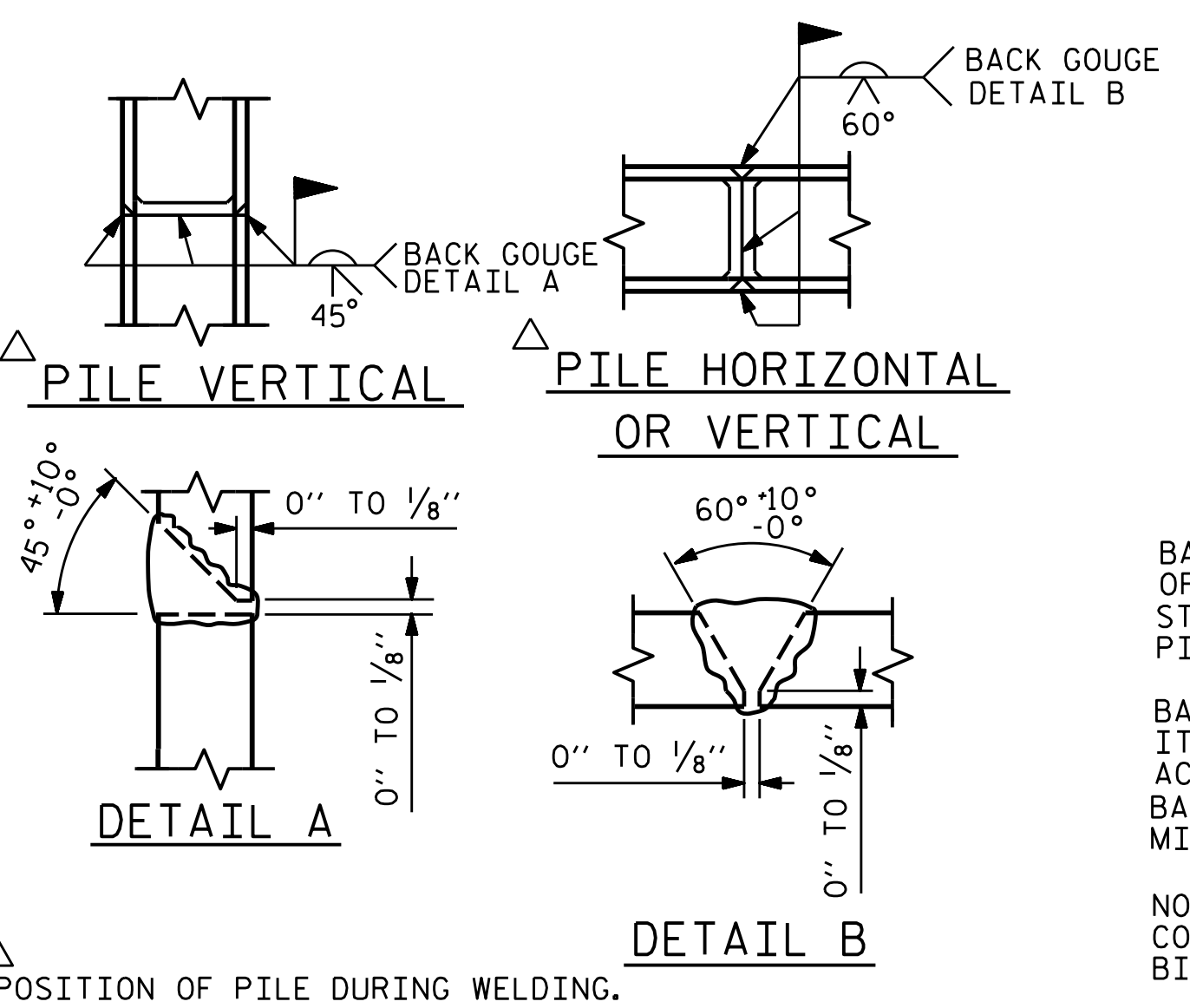

PILE SPLICE DETAILS

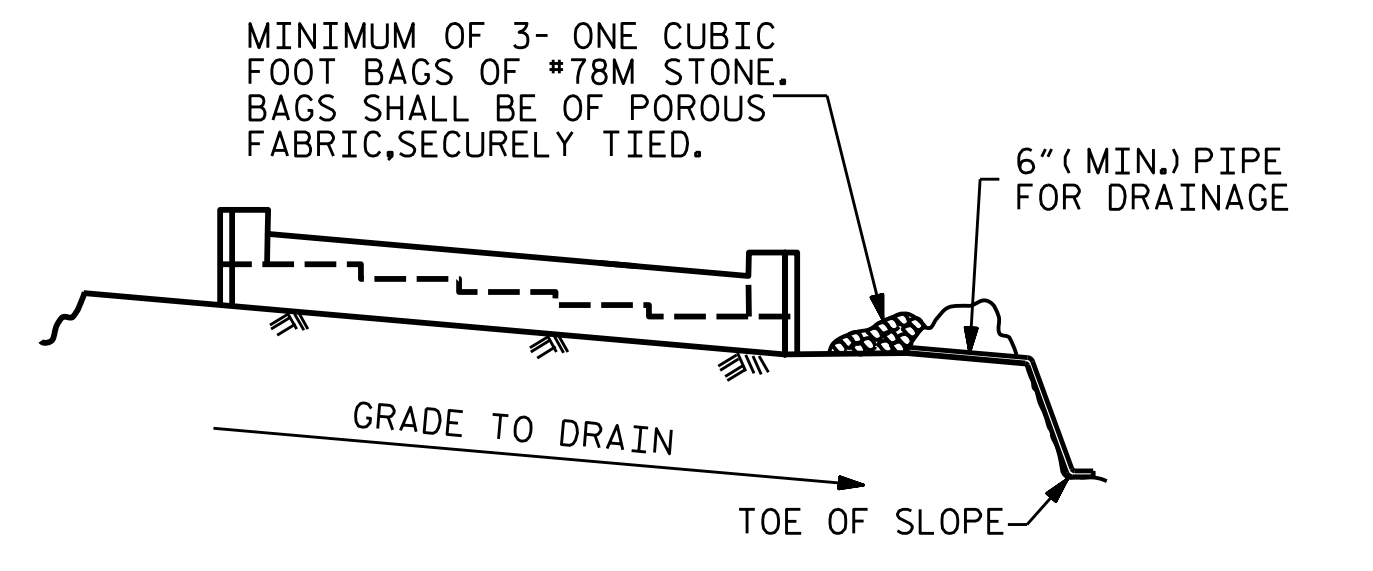

MINIMUM OF 3- ONE CUBIC FOOT BAGS OF #78M STONE. BAGS SHALL BE OF POROUS FABRIC, SECURELY TIED.

BAGGED STONE AND PIPE SHALL BE PLACED IMMEDIATELY AFTER COMPLETION OF END BENT EXCAVATION. PIPE MAY BE EITHER CONCRETE, CORRUGATED STEEL, CORRUGATED ALUMINUM ALLOY, OR CORRUGATED PLASTIC. PERFORATED PIPE WILL NOT BE ALLOWED.

BAGGED STONE SHALL REMAIN IN PLACE UNTIL THE ENGINEER DIRECTS THAT IT BE REMOVED. THE CONTRACTOR SHALL REMOVE AND DISPOSE OF SILT ACCUMULATIONS AT BAGGED STONE WHEN SO DIRECTED BY THE ENGINEER. BAGS SHALL BE REMOVED AND REPLACED WHENEVER THE ENGINEER DETERMINES THAT THEY HAVE DETERIORATED AND LOST THEIR EFFECTIVENESS.

NO SEPARATE PAYMENT WILL BE MADE FOR THIS WORK AND THE ENTIRE COST OF THIS WORK SHALL BE INCLUDED IN THE UNIT CONTRACT PRICE BID FOR THE SEVERAL PAY ITEMS.

TEMPORARY DRAINAGE AT END BENT

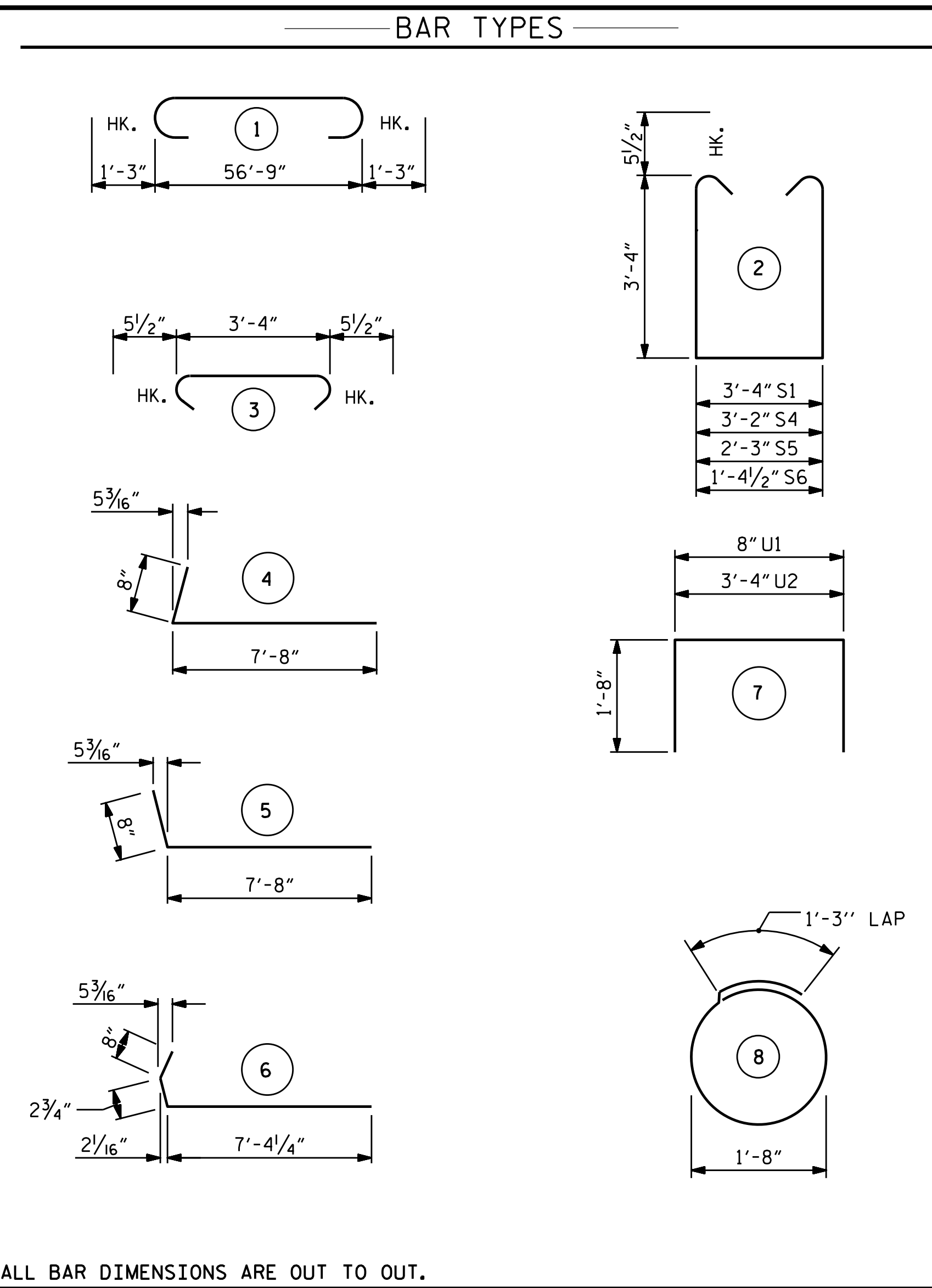

ALL BAR DIMENSIONS ARE OUT TO OUT.

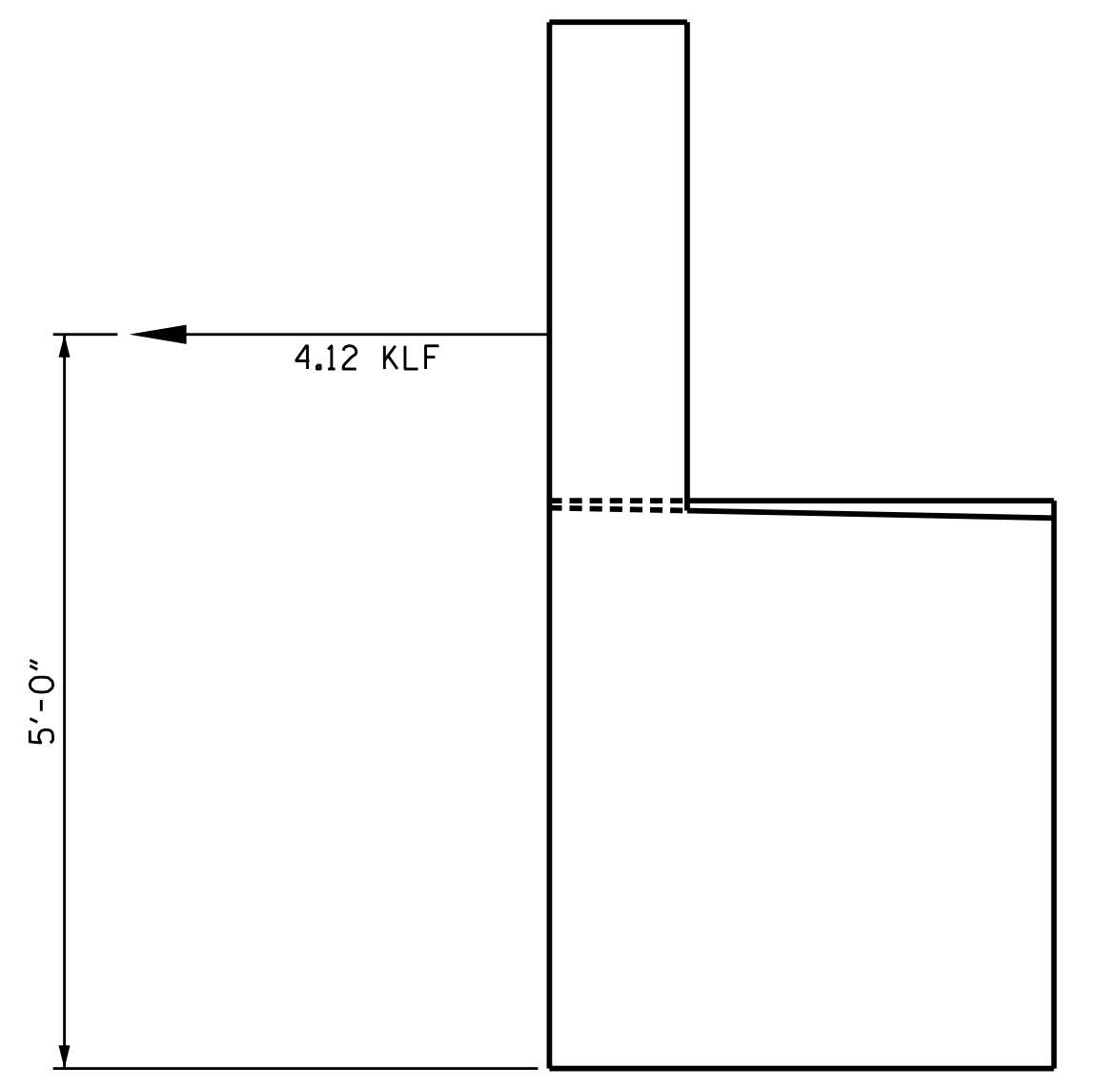

STRAP LOAD DETAIL

BILL OF MATERIAL					
END BENT #2					
BAR	NO.	SIZE	TYPE	LENGTH	WEIGHT
B1	5	9	1	59'-3"	1007
B2	6	9	1	59'-3"	1209
B3	4	9	STR	56'-9"	772
B4	14	4	STR	29'-7"	277
B5	14	4	STR	3'-4"	31
B6	5	4	STR	19'-2"	64
B7	25	4	STR	3'-2"	53
H1	20	5	4	8'-4"	174
H2	10	5	5	8'-2 3/4"	86
H3	10	5	6	8'-4"	87
K1	8	4	STR	29'-7"	158
K2	6	4	STR	3'-6"	14
K3	2	4	STR	3'-4"	4
S1	60	5	2	7'-11"	495
S2	66	5	3	4'-3"	293
S3	28	5	8	6'-6"	190
S4	2	5	2	7'-9"	16
S5	2	5	2	6'-10"	14
S6	2	5	2	5'-11 1/2"	12
U1	49	4	7	4'-0"	131
U2	27	4	7	6'-8"	120
V1	98	5	STR	7'-2"	733
V2	24	5	STR	8'-6"	213
V3	24	5	STR	8'-11"	223
REINFORCING STEEL					LBS. 6376
CLASS "A" CONCRETE BREAKDOWN					
POUR #1 CAP AND LOWER WINGS					33.8 C.Y.
POUR #2 BACKWALL & UPPER WINGS					10.5 C.Y.
TOTAL					44.3 C.Y.
HP 12 x 53 STEEL PILES					LIN. FEET. 595
No. = 7					
PILE REDRIVES					EA. 4

PROJECT NO. U-4405
 CUMBERLAND COUNTY
 STATION: 26+78.00 -RPB-

SHEET 3 OF 3

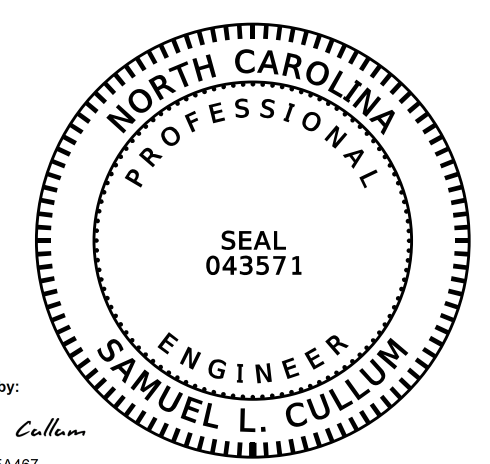

STATE OF NORTH CAROLINA
 DEPARTMENT OF TRANSPORTATION
 RALEIGH
 SUBSTRUCTURE
 END BENT #2

REVISIONS						SHEET NO.
NO.	BY:	DATE:	NO.	BY:	DATE:	S-22
1			3			TOTAL SHEETS 26
2			4			

DOCUMENT NOT CONSIDERED FINAL UNLESS ALL SIGNATURES COMPLETED

KCA 4800 SIX FORKS ROAD SUITE 120
 RALEIGH, NC 27609
 KISINGER CAMPO & ASSOCIATES (919) 882-7839

DRAWN BY: J. B. HANNA DATE: 05-17
 CHECKED BY: L. MARTINEZ DATE: 05-17
 DESIGN ENGINEER OF RECORD: S. CULLUM DATE: 05-17

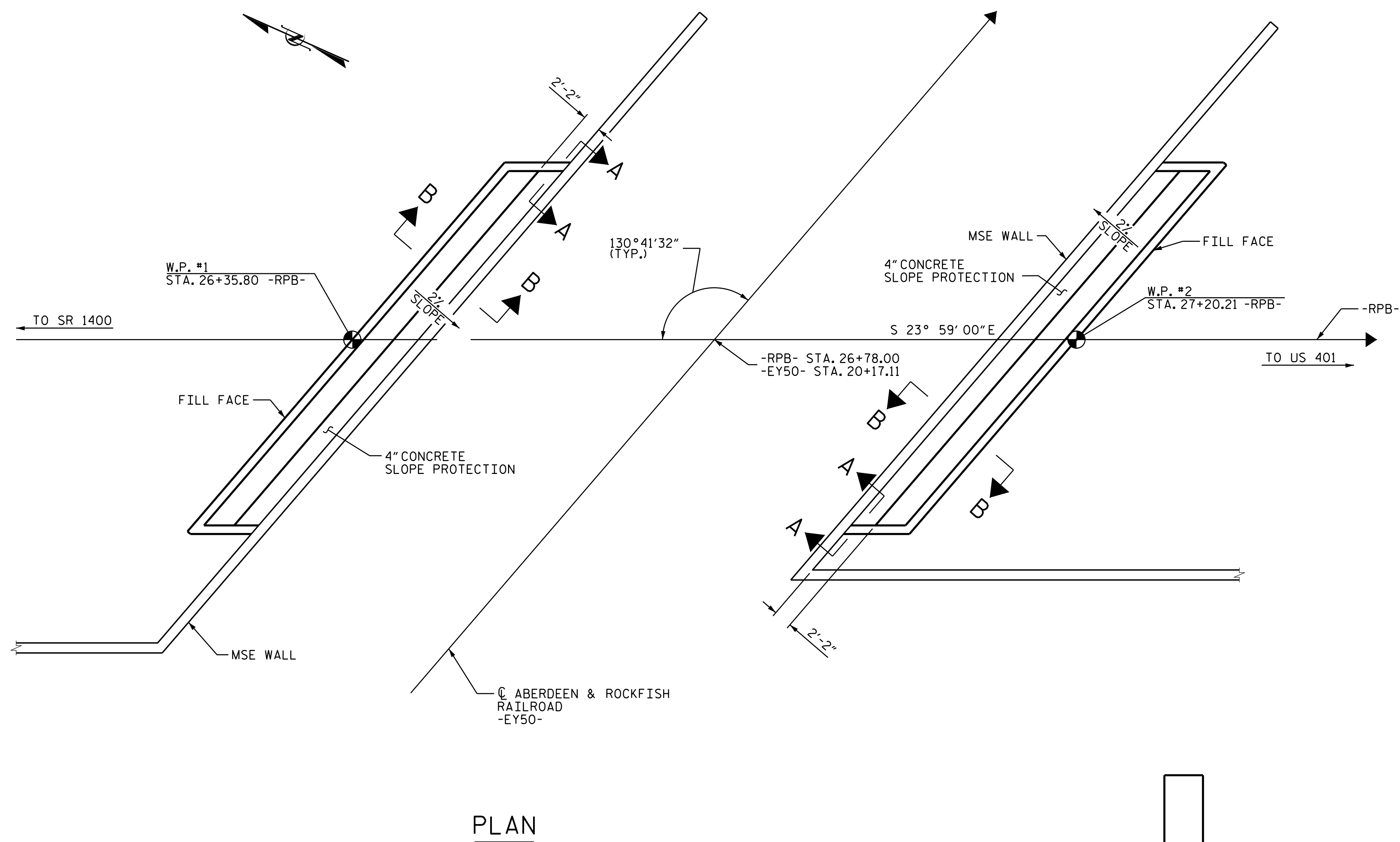

PLAN

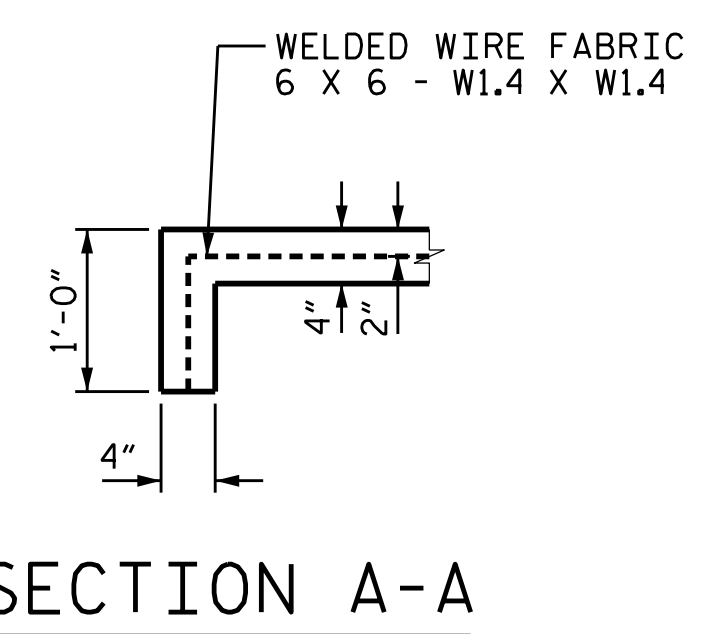

SECTION A-A

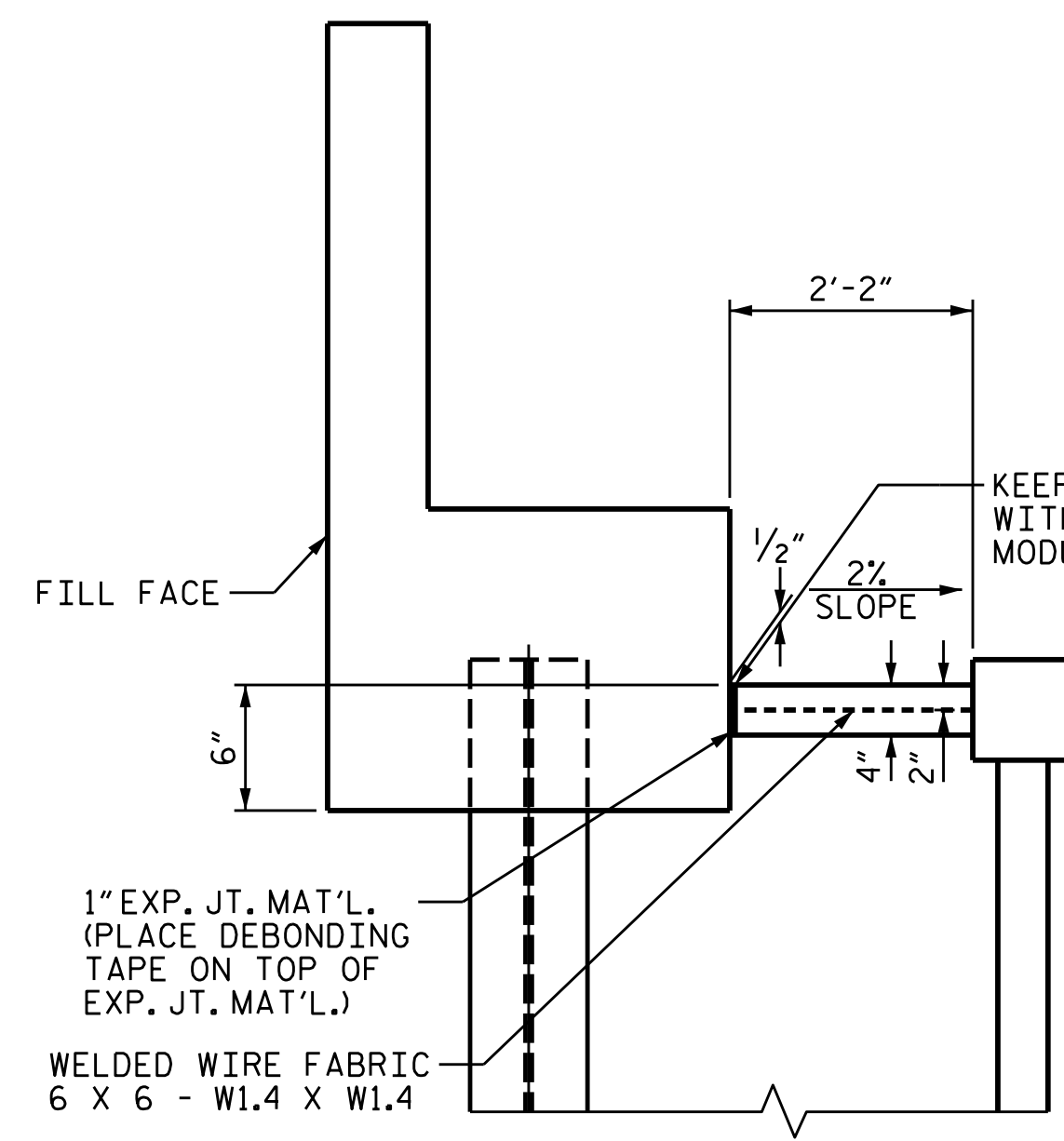

SECTION B-B

END BENT #1 SHOWN,
END BENT #2 SIMILAR

GENERAL NOTES

SLOPE PROTECTION SHALL BE PLACED UNDER THE ENDS OF THE BRIDGE AS SHOWN IN THE DETAILS. STRAIGHT EDGING WILL NOT BE REQUIRED UNLESS, IN THE OPINION OF THE ENGINEER, VISUAL INSPECTION INDICATES A NEED FOR IT. MEASUREMENT AND PAYMENT SHALL BE AS PRESCRIBED IN SECTION 462 OF THE STANDARD SPECIFICATIONS.

SLOPE PROTECTION SHALL CONSIST OF 4"POURED-IN-PLACE CONCRETE PAVING AS SHOWN IN THE DETAILS ON THIS SHEET. CONCRETE SHALL BE CLASS "B". THE CONCRETE SURFACE SHALL BE FLOATED WITH A WOODEN FLOAT AND FINISHED. WELDED WIRE FABRIC REINFORCING SHALL BE 6 X 6 - W1.4 X W1.4, 60" WIDE. SLOPE PROTECTION SHALL BE POURED IN 5' STRIPS AS SHOWN IN THE "POURING DETAIL" WITH 2'-0" LONG #4 BARS PLACED ALONG THE SLOPE BETWEEN STRIPS AT 1'-6" MAXIMUM SPACING. SLOPE PROTECTION MAY BE POURED IN ALTERNATE 4' AND 5' STRIPS AS SHOWN IN THE "OPTIONAL POURING DETAIL" WITH ADJACENT RUNS OF WELDED WIRE FABRIC LAPPING AT LEAST 6". THE COST OF THE WELDED WIRE FABRIC AND #4 BARS, IF USED, SHALL BE INCLUDED IN THE CONTRACT UNIT PRICE BID PER SQUARE YARD FOR SLOPE PROTECTION.

BRIDGE @ STA. 26+78.00 -RPB-	4 INCH SLOPE PROTECTION	* WELDED WIRE FABRIC 60 INCHES WIDE
	SQUARE YARDS	APPROX. LF.
END BENT 1	14	26
END BENT 2	14	26

* QUANTITY SHOWN IS BASED ON 5' POURS.

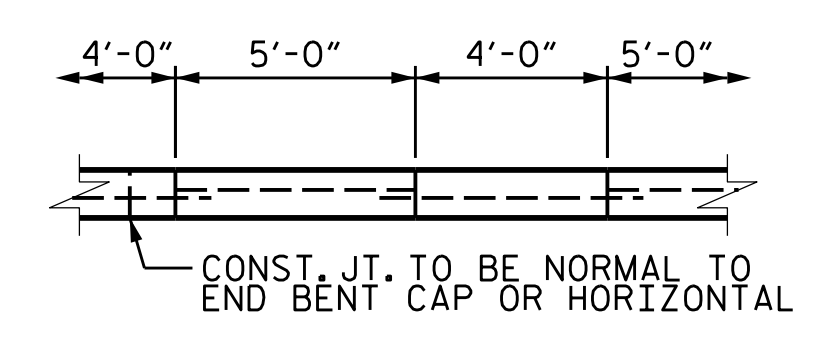

OPTIONAL POURING DETAIL

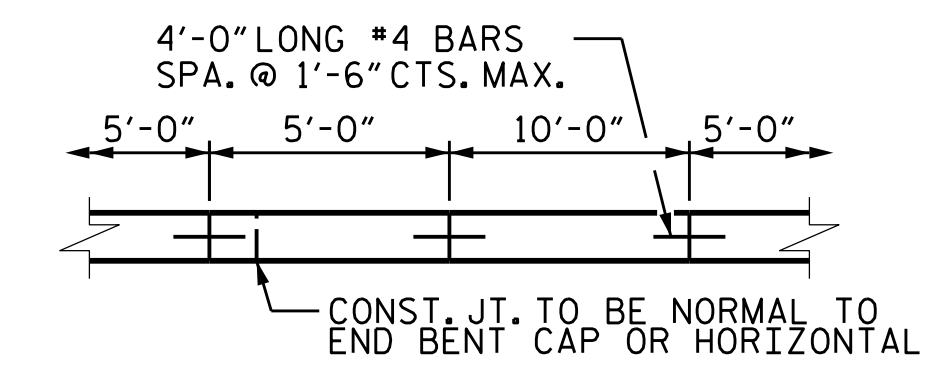

POURING DETAIL

PROJECT NO. U-4405
CUMBERLAND COUNTY
 STATION: 26+78.00 -RPB-

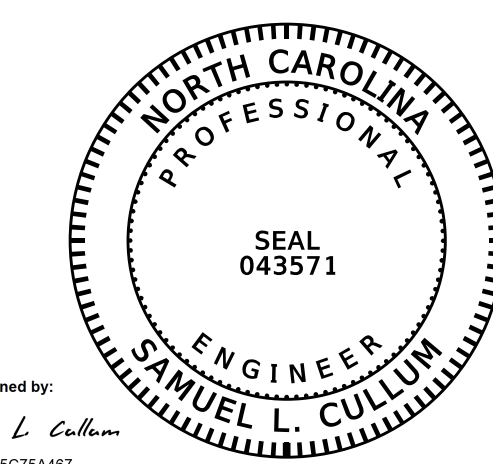

STATE OF NORTH CAROLINA
 DEPARTMENT OF TRANSPORTATION
 RALEIGH

**SLOPE PROTECTION
 DETAILS**

KCA 4800 SIX FORKS ROAD SUITE 120
 KISINGER CAMPO & ASSOCIATES RALEIGH, NC 27609
 (919) 882-7839

DRAWN BY: J. HANNA DATE: 05-17
 CHECKED BY: L. MARTINEZ DATE: 05-17
 DESIGN ENGINEER OF RECORD: S. CULLUM DATE: 05-17

REVISIONS						SHEET NO.
NO.	BY:	DATE:	NO.	BY:	DATE:	S-23
1			3			TOTAL SHEETS
2			4			26

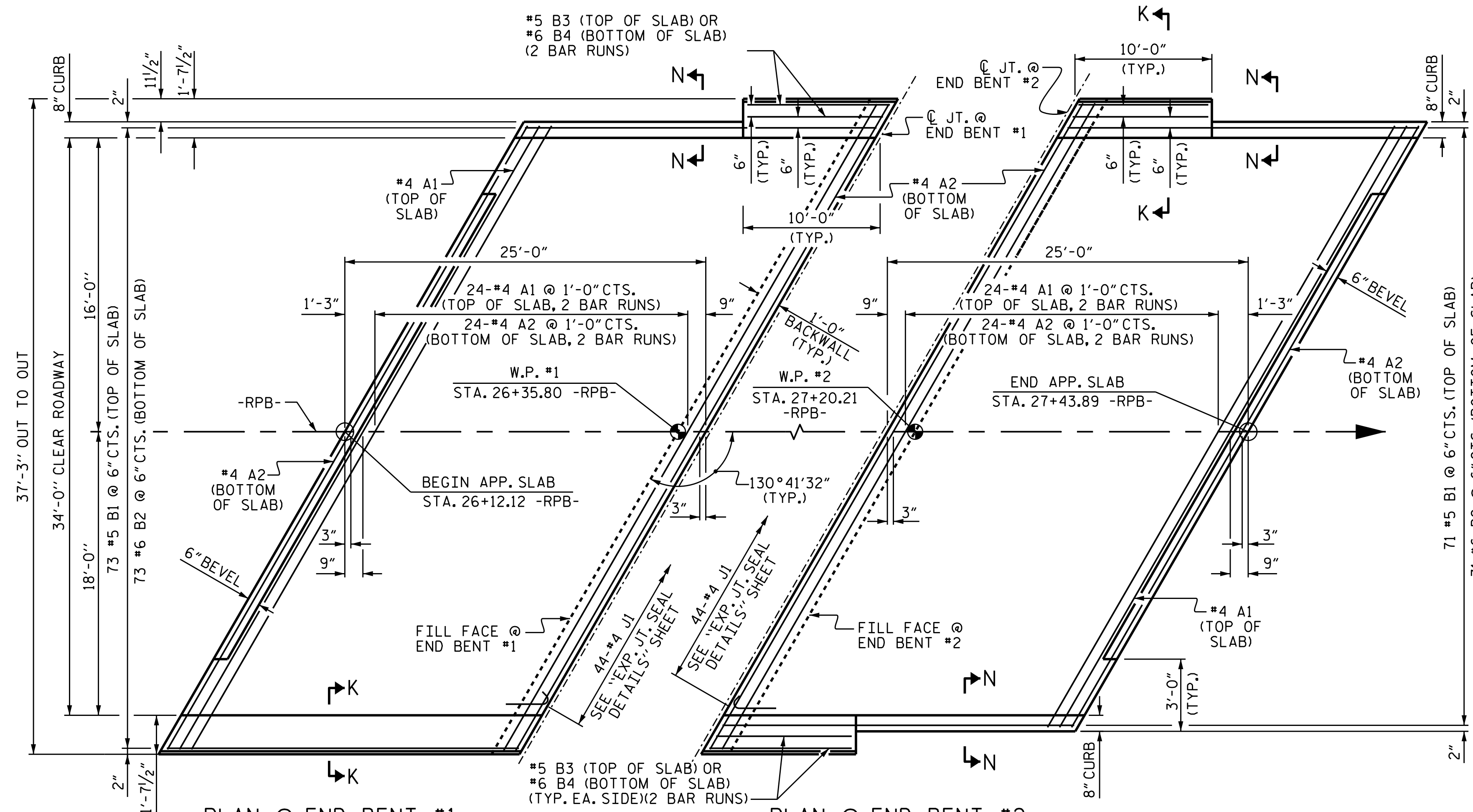

PLAN @ END BENT #1
 PLAN @ END BENT #2
 DIMENSIONS SHOWN ARE TYPICAL FOR BOTH APPROACH SLABS

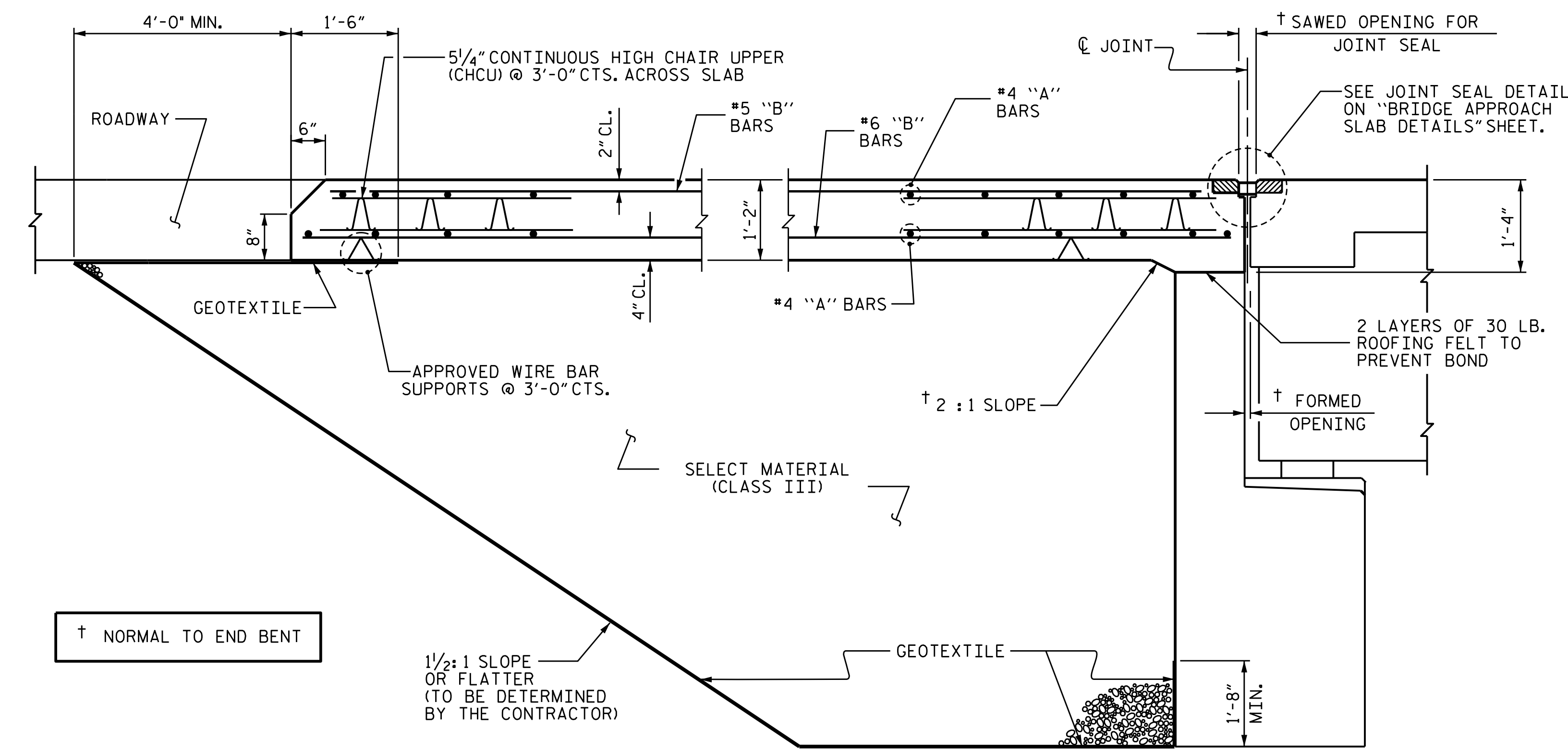

SECTION THRU SLAB

(TYPE III - STANDARD APPROACH FILL)
 (SEE NCDOT ROADWAY DETAIL DRAWING 422D10)

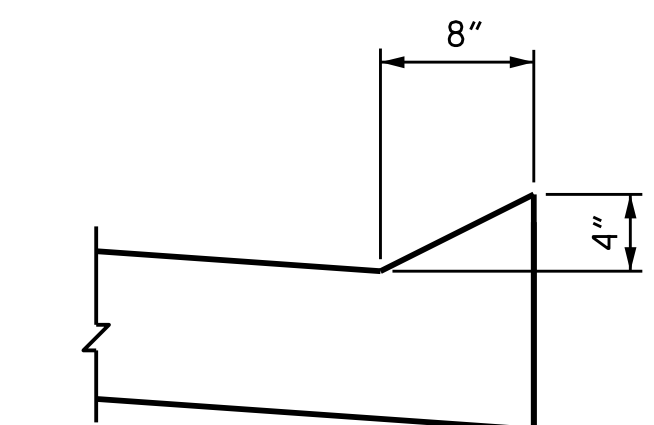

SECTION N-N

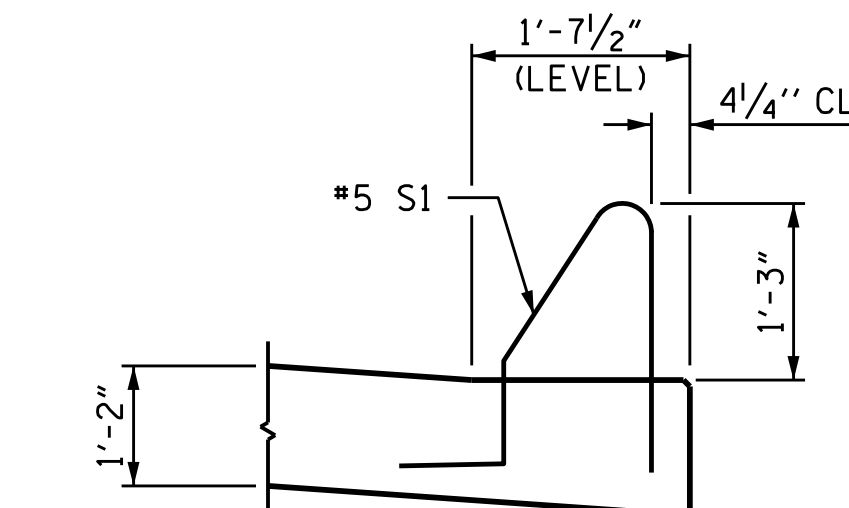

SECTION K-K

END OF CURB WITHOUT
 SHOULDER BERM GUTTER

CURB DETAILS

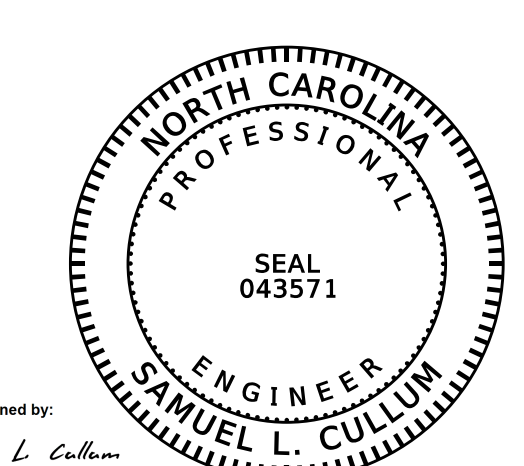

6/6/2018 12:30:46 PM PDT

DOCUMENT NOT CONSIDERED
 FINAL UNLESS ALL
 SIGNATURES COMPLETED

NOTES

- FOR BRIDGE APPROACH FILL INCLUDING GEOTEXTILE, 6" Ø DRAINAGE PIPE, AND SELECT MATERIAL BACKFILL, SEE ROADWAY PLANS.
- GEOTEXTILE SHALL BE TYPE 1 IN ACCORDANCE WITH THE STANDARD SPECIFICATIONS SECTION 1056.
- SELECT MATERIAL BACKFILL (CLASS III) SHALL BE IN ACCORDANCE WITH STANDARD SPECIFICATIONS SECTION 1016.
- SELECT MATERIAL BACKFILL IS TO BE CONTINUOUS ALONG FILL FACE OF BACKWALL FROM OUTSIDE EDGE TO OUTSIDE EDGE OF APPROACH SLAB.
- APPROACH SLAB SHALL NOT BE CONSTRUCTED PRIOR TO COMPLETION OF THE BRIDGE DECK.
- THE JOINT SHALL BE SAWS PRIOR TO THE CASTING OF THE BARRIER RAIL OR PARAPET AND END POST.
- FOR THE 6" Ø DRAINAGE PIPE OUTLET(S), SEE ROADWAY STANDARD DRAWINGS.
- AREA BETWEEN THE WINGWALL AND APPROACH SLAB SHALL BE GRADED TO DRAIN THE WATER AWAY FROM THE FILL FACE OF THE BRIDGE AND SHALL BE PAVED. SEE ROADWAY PLANS.

BILL OF MATERIAL					
APPROACH SLAB AT EB #1					
BAR	NO.	SIZE	TYPE	LENGTH	WEIGHT
*A1	50	#4	STR	25'-9"	860
A2	52	#4	STR	25'-6"	886
*B1	73	#5	STR	23'-8"	1802
B2	73	#6	STR	24'-8"	2705
*B3	4	#5	STR	6'-9"	28
B4	4	#6	STR	6'-10"	41
*J1	44	#4	1	1'-6"	42
REINFORCING STEEL				LBS.	3632
*EPOXY COATED REINFORCING STEEL				LBS.	2732
CLASS AA CONCRETE				C. Y.	39.8
APPROACH SLAB AT EB #2					
BAR	NO.	SIZE	TYPE	LENGTH	WEIGHT
A1	50	#4	STR	25'-9"	860
*A2	52	#4	STR	25'-6"	886
B1	71	#5	STR	23'-8"	1753
B2	71	#6	STR	24'-8"	2631
*B3	8	#5	STR	6'-9"	56
B4	8	#6	STR	6'-6"	82
*J1	44	#4	1	1'-6"	42
REINFORCING STEEL				LBS.	3599
*EPOXY COATED REINFORCING STEEL				LBS.	2711
CLASS AA CONCRETE				C. Y.	39.3

SPlice LENGTHS		
BAR SIZE	EPOXY COATED	UNCOATED
#4	2'-0"	1'-9"
#5	2'-6"	2'-2"
#6	3'-10"	2'-7"

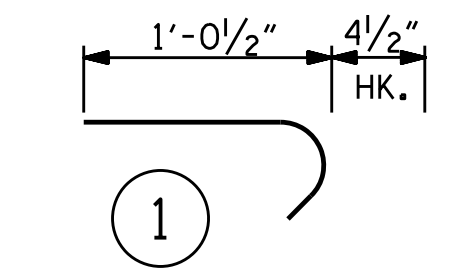

ALL BAR DIMENSIONS ARE OUT TO OUT

THE QUANTITY OF #4 JI BARS ON THE BILL OF MATERIAL IS BASED ON 1'-0" CENTERS. JI BARS SHALL BE PLACED AT EACH VERTICAL STUD ANCHOR BOLT. IN THE EVENT THAT THE NUMBER OF VERTICAL STUD ANCHORS EXCEEDS THE NUMBER OF JI BARS SPECIFIED, ADDITIONAL JI BARS WILL NOT BE REQUIRED.

PROJECT NO. U-4405
CUMBERLAND COUNTY
 STATION: 26+78.00 -RPB-

STATE OF NORTH CAROLINA
 DEPARTMENT OF TRANSPORTATION
 RALEIGH
 STANDARD
 BRIDGE APPROACH SLAB
 FOR FLEXIBLE PAVEMENT

REVISIONS						SHEET NO.
NO.	BY:	DATE:	NO.	BY:	DATE:	S-24
1			3			TOTAL SHEETS
2			4			26

KCA 4800 SIX FORKS ROAD SUITE 120
 RALEIGH, NC 27609
 (919) 882-7839

ASSEMBLED BY: J. B. HANNA DATE: 05-17
 CHECKED BY: L. MARTINEZ DATE: 05-17

DRAWN BY: EEM 3/95 REV. 10/17/11 MAA/GM
 CHECKED BY: VAP 3/95 REV. 12/21/11 MAA/GM
 REV. 6/13 MAA/GM

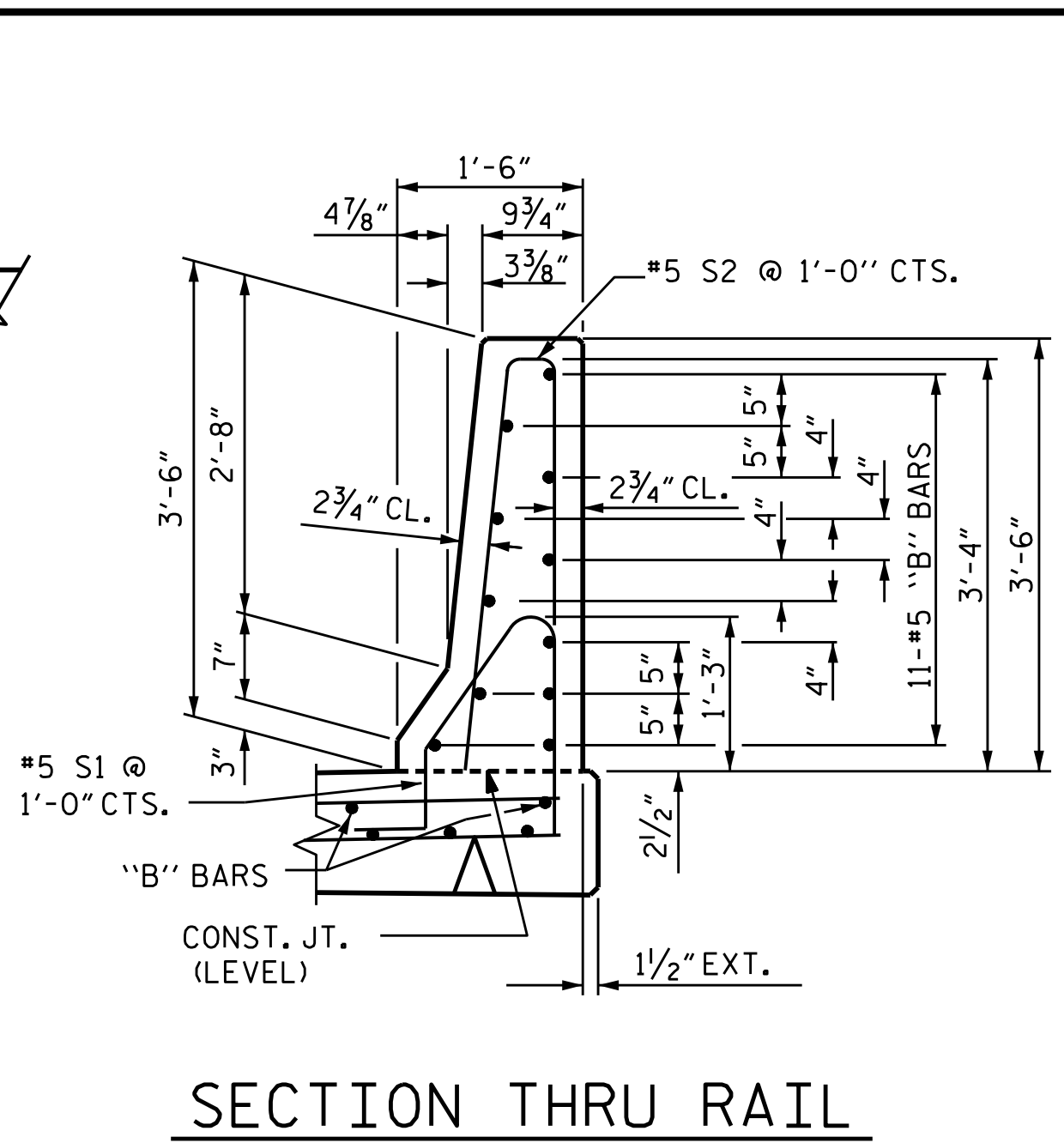
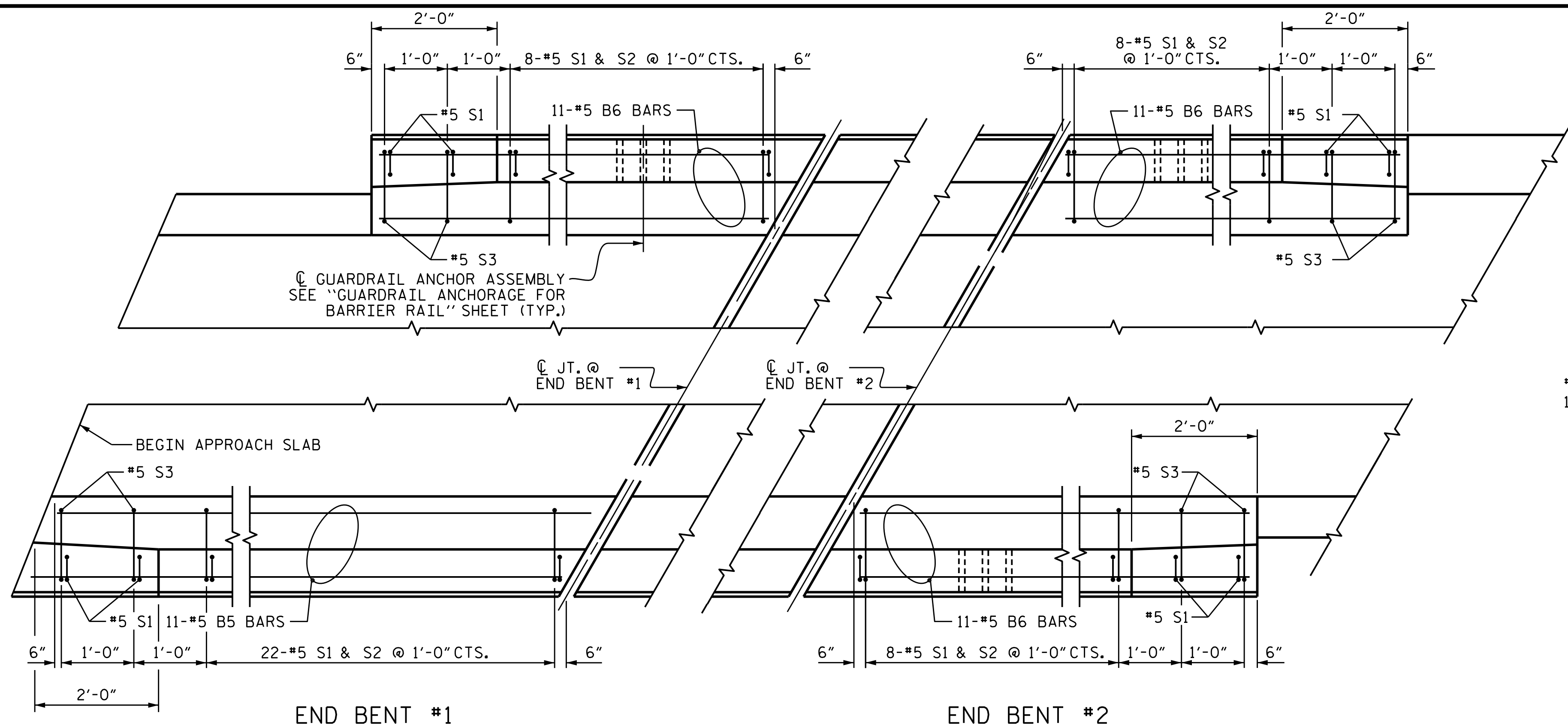

BAR TYPES

ALL BAR DIMENSIONS ARE OUT TO OUT

BARRIER RAIL ONLY					
BAR NO.	SIZE	TYPE	LENGTH	WEIGHT	
*B5	11	#5	STR	24'-8"	283
*B6	33	#5	STR	9'-6"	327
*S1	54	#5	1	5'-1"	286
*S2	46	#5	2	7'-0"	336
*S3	8	#5	2	5'-6"	46

* EPOXY COATED REINFORCING STEEL 1278
 CLASS AA CONCRETE 7.7 C. Y.
 CONCRETE BARRIER RAIL 57.0 LIN. FT.

END BENT #1 END BENT #2
PLAN OF BARRIER RAIL

NOTES

THE COST OF THE BARRIER RAIL ON THE APPROACH SLAB SHALL BE INCLUDED IN THE LINEAR FOOT CONTRACT PRICE BID FOR "CONCRETE BARRIER RAIL".

THE BARRIER RAIL ON EACH APPROACH SLAB SHALL NOT BE CAST UNTIL ALL APPROACH SLAB CONCRETE HAS BEEN CAST AND HAS REACHED A MINIMUM COMPRESSIVE STRENGTH OF 3,000 PSI.

ALL REINFORCING STEEL IN BARRIER RAILS SHALL BE EPOXY COATED.

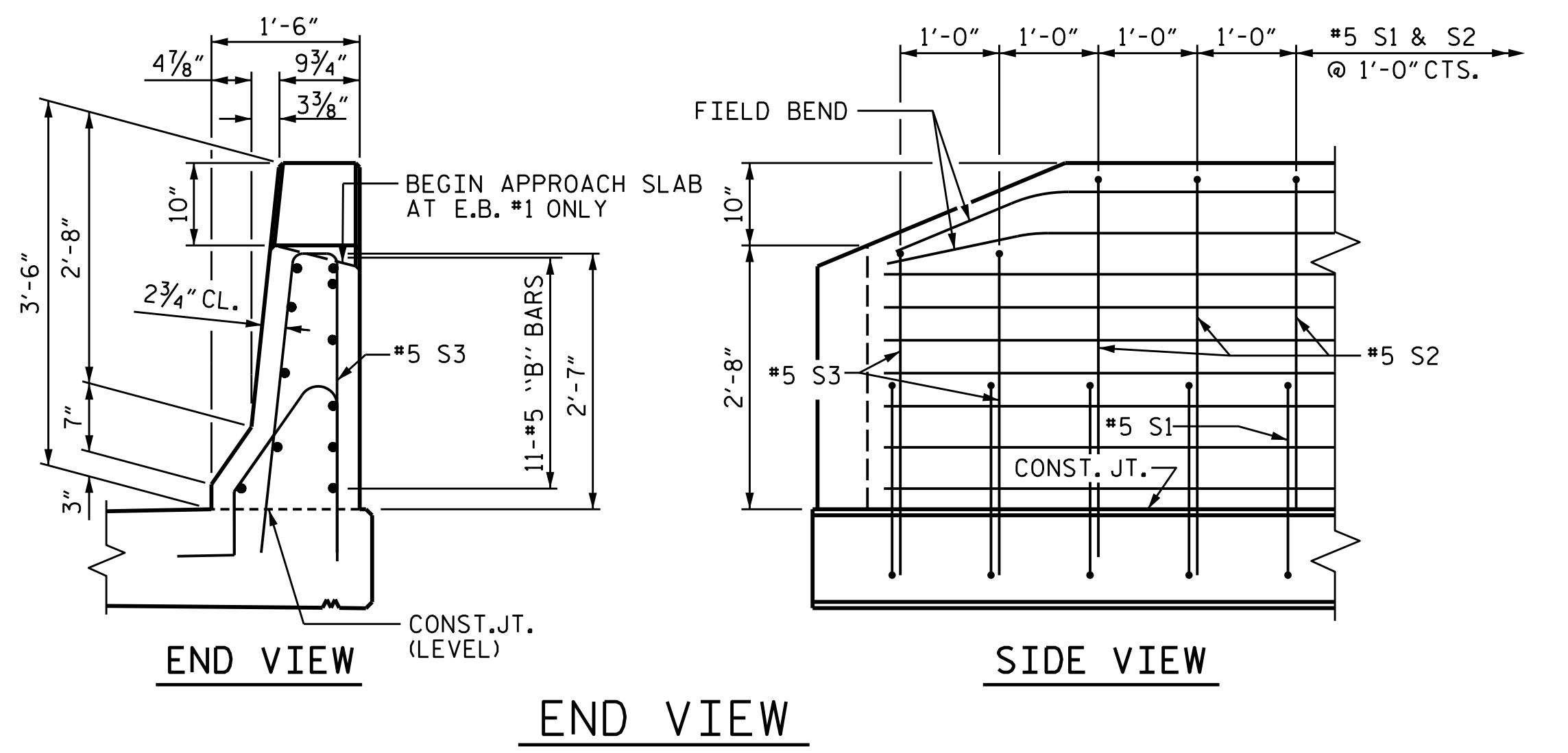

END VIEW END VIEW SIDE VIEW

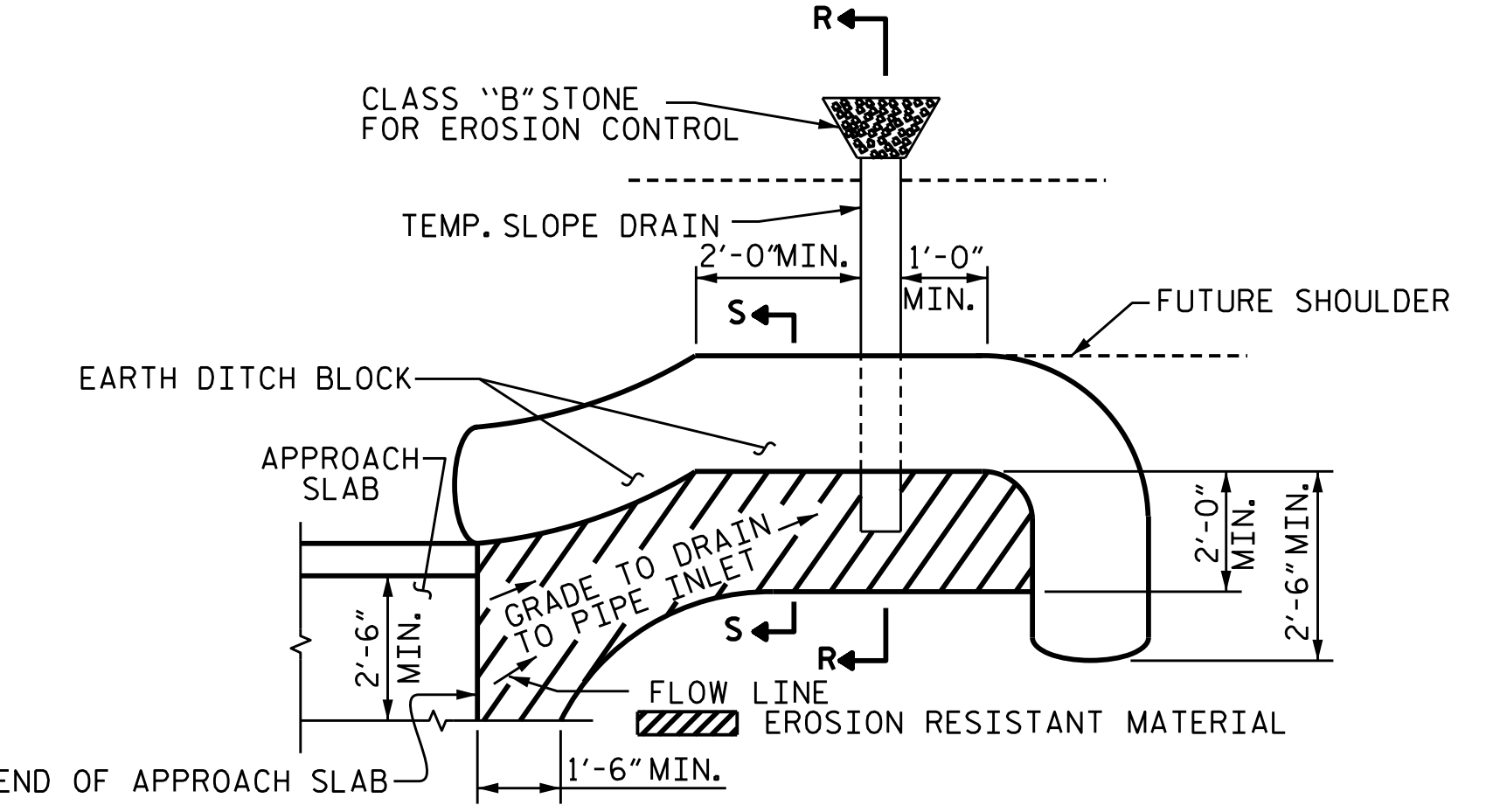

PLAN VIEW

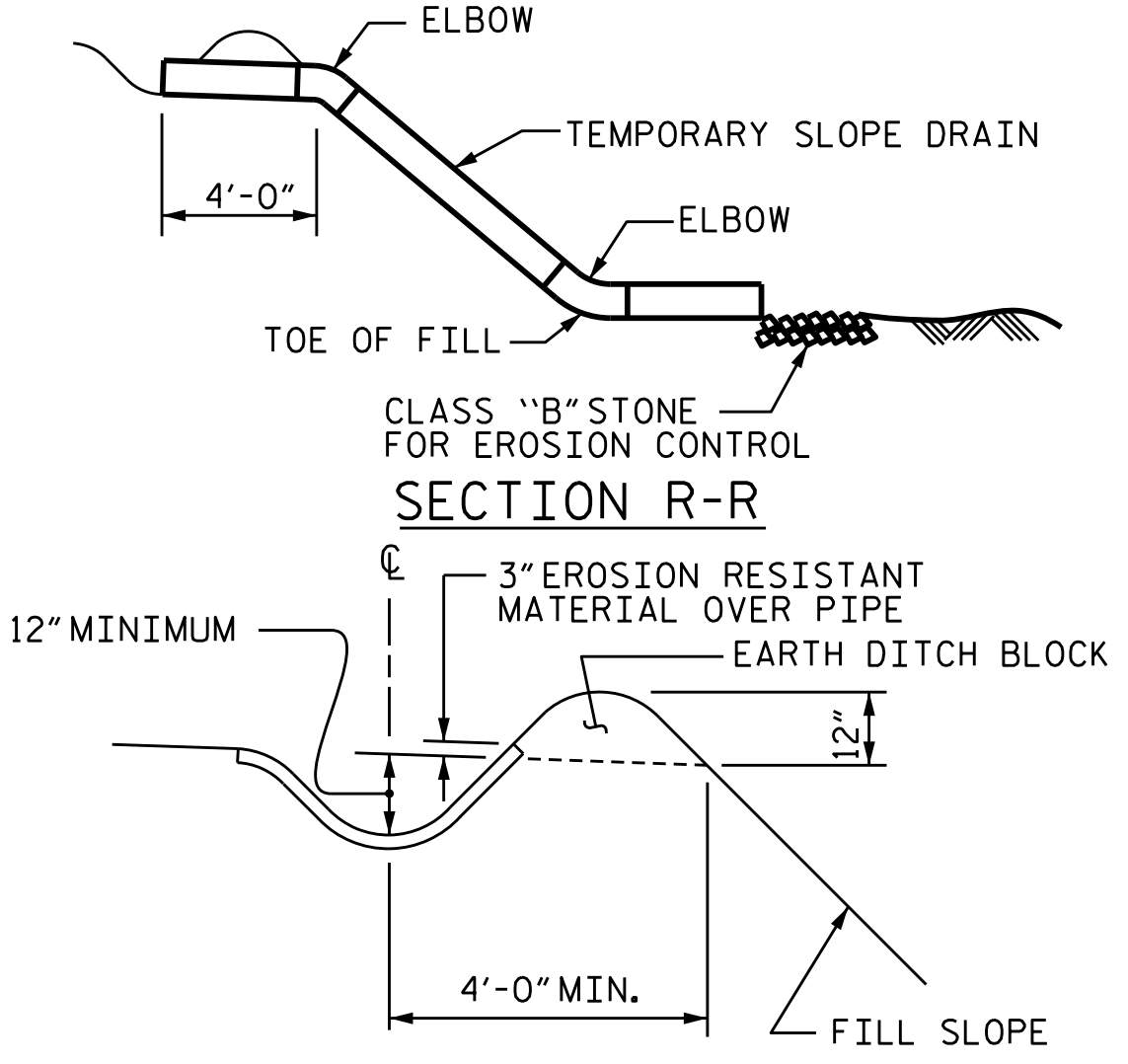

SECTION S-S

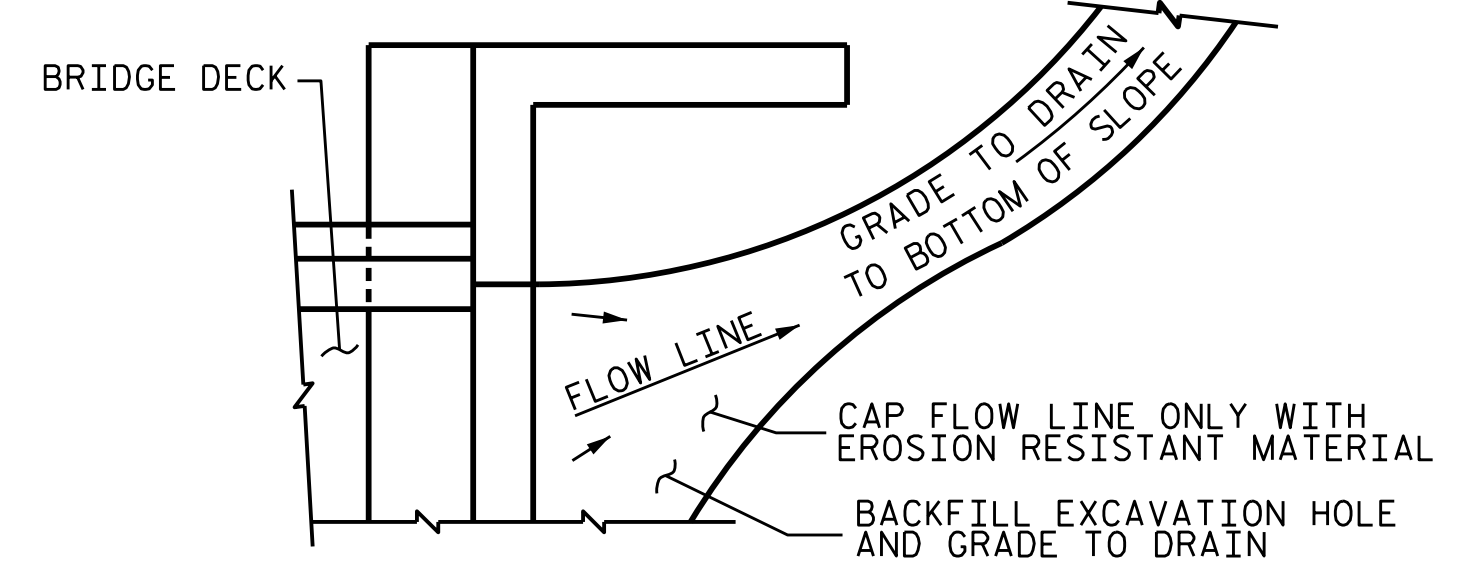

TEMPORARY DRAINAGE DETAIL

NOTE: IF THE APPROACH SLAB IS NOT CONSTRUCTED IMMEDIATELY AFTER THE BACKFILLING OF THE END BENT EXCAVATION, GRADE TO DRAIN TO THE BOTTOM OF THE SLOPE AND PROVIDE EROSION RESISTANT MATERIAL, SUCH AS FIBERGLASS ROVING OR AS DIRECTED BY THE ENGINEER TO PREVENT SOIL EROSION AND TO PROTECT THE AREA ADJACENT TO THE STRUCTURE. THE CONTRACTOR WILL BE REQUIRED TO REMOVE THESE MATERIALS PRIOR TO CONSTRUCTION OF THE APPROACH SLAB.

NOTE: IMMEDIATELY AFTER THE CONSTRUCTION OF THE APPROACH SLAB, THE CONTRACTOR SHALL PROVIDE TEMPORARY BERM AND SLOPE DRAIN. CONTRACTOR SHALL GRADE TO PIPE INLET AND PROVIDE EROSION RESISTANT MATERIAL AS SHOWN. THE EROSION RESISTANT MATERIAL SHALL BE EITHER 1) ASPHALT PLANT MIX, TYPE 1 OR TYPE 2, MIN. 2" DEPTH, 2) EROSION CONTROL MAT, OR 3) CONCRETE, AS DIRECTED BY THE ENGINEER. THE SLOPE DRAIN SHALL CONSIST OF A NON-PERFORATED TEMPORARY DRAINAGE PIPE, 12 INCHES IN DIAMETER.

PROJECT NO. U-4405
CUMBERLAND COUNTY
 STATION: 26+78.00 -RPB-

STATE OF NORTH CAROLINA
 DEPARTMENT OF TRANSPORTATION
 RALEIGH

STANDARD
 BRIDGE APPROACH
 SLAB DETAILS

REVISIONS						SHEET NO.
NO.	BY:	DATE:	NO.	BY:	DATE:	S-25
1			3			TOTAL SHEETS
2			4			26

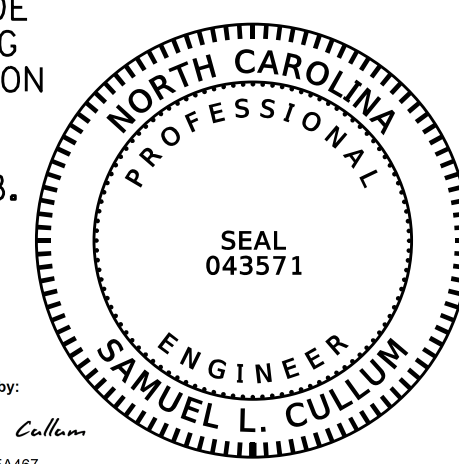

6/6/2018 12:30:46 PM PDT

DOCUMENT NOT CONSIDERED FINAL UNLESS ALL SIGNATURES COMPLETED

KCA 4800 SIX FORKS ROAD SUITE 120
 KISINGER CAMPO & ASSOCIATES RALEIGH, NC 27609
 (919) 882-7839

ASSEMBLED BY : J. B. HANNA DATE : 05-17
 CHECKED BY : L. MARTINEZ DATE : 05-17

DRAWN BY : FCJ 11/88 MAA/GM
 CHECKED BY : ARB 11/88 REV. 7/12 MAA/GM
 REV. 6/13 MAA/GM

TEMPORARY BERM AND SLOPE DRAIN DETAILS
 (TO BE USED WHEN SHOULDER BERM GUTTER IS REQUIRED)

STANDARD NOTES

DESIGN DATA:

SPECIFICATIONS	- - - - -	A.A.S.H.T.O. (CURRENT)
LIVE LOAD	- - - - -	SEE PLANS
IMPACT ALLOWANCE	- - - - -	SEE A.A.S.H.T.O.
STRESS IN EXTREME FIBER OF STRUCTURAL STEEL - AASHTO M270 GRADE 36	- -	20,000 LBS. PER SQ. IN.
- AASHTO M270 GRADE 50W	- -	27,000 LBS. PER SQ. IN.
- AASHTO M270 GRADE 50	- -	27,000 LBS. PER SQ. IN.
REINFORCING STEEL IN TENSION - GRADE 60	- - -	24,000 LBS. PER SQ. IN.
CONCRETE IN COMPRESSION	- - - - -	1,200 LBS. PER SQ. IN.
CONCRETE IN SHEAR	- - - - -	SEE A.A.S.H.T.O.
STRUCTURAL TIMBER - TREATED OR UNTREATED EXTREME FIBER STRESS	- - -	1,800 LBS. PER SQ. IN.
COMPRESSION PERPENDICULAR TO GRAIN OF TIMBER	- - - - -	375 LBS. PER SQ. IN.
EQUIVALENT FLUID PRESSURE OF EARTH	- - - - -	30 LBS. PER CU. FT. (MINIMUM)

MATERIAL AND WORKMANSHIP:

EXCEPT AS MAY OTHERWISE BE SPECIFIED ON PLANS OR IN THE SPECIAL PROVISIONS, ALL MATERIAL AND WORKMANSHIP SHALL BE IN ACCORDANCE WITH THE 2018 "STANDARD SPECIFICATIONS FOR ROADS AND STRUCTURES" OF THE N.C. DEPARTMENT OF TRANSPORTATION.

STEEL SHEET PILING FOR PERMANENT OR TEMPORARY APPLICATIONS SHALL BE HOT ROLLED.

CONCRETE:

UNLESS OTHERWISE REQUIRED ON PLANS, CLASS A CONCRETE SHALL BE USED FOR ALL PORTIONS OF ALL STRUCTURES WITH THE EXCEPTION THAT: CLASS AA CONCRETE SHALL BE USED IN BRIDGE SUPERSTRUCTURES, ABUTMENT BACKWALLS, AND APPROACH SLABS; AND CLASS B CONCRETE SHALL BE USED FOR SLOPE PROTECTION AND RIP RAP.

CONCRETE CHAMFERS:

UNLESS OTHERWISE NOTED ON THE PLANS, ALL EXPOSED CORNERS ON STRUCTURES SHALL BE CHAMFERED $\frac{3}{4}$ " WITH THE FOLLOWING EXCEPTIONS: TOP CORNERS OF CURBS MAY BE ROUNDED TO $1\frac{1}{2}$ " RADIUS WHICH IS BUILT INTO CURB FORMS; CORNERS OF TRANSVERSE FLOOR EXPANSION JOINTS SHALL BE ROUNDED WITH A $\frac{1}{4}$ " FINISHING TOOL UNLESS OTHERWISE REQUIRED ON PLANS; AND CORNERS OF EXPANSION JOINTS IN THE ROADWAY FACES AND TOPS OF CURBS AND SIDEWALKS SHALL BE ROUNDED TO A $\frac{1}{4}$ " RADIUS WITH A FINISHING STONE OR TOOL UNLESS OTHERWISE REQUIRED ON PLANS.

DOWELS:

DOWELS WHEN INDICATED ON PLANS AS FOR CULVERT EXTENSIONS, SHALL BE EMBEDDED AT LEAST 12" INTO THE OLD CONCRETE AND GROUTED INTO PLACE WITH 1:2 CEMENT MORTAR.

ALLOWANCE FOR DEAD LOAD DEFLECTION, SETTLEMENT, ETC. IN CASTING SUPERSTRUCTURES:

BRIDGES SHALL BE BUILT ON THE GRADE OR VERTICAL CURVE SHOWN ON PLANS. SLABS, CURBS AND PARAPETS SHALL CONFORM TO THE GRADE OR CURVE.

ALL DIMENSIONS WHICH ARE GIVEN IN SECTION AND ARE AFFECTED BY DEAD LOAD DEFLECTIONS ARE DIMENSIONS AT CENTER LINE OF BEARING UNLESS OTHERWISE NOTED ON PLANS. IN SETTING FORMS FOR STEEL BEAM BRIDGES AND PRESTRESSED CONCRETE GIRDER BRIDGES, ADJUSTMENTS SHALL BE MADE DUE TO THE DEAD LOAD DEFLECTIONS FOR THE ELEVATIONS SHOWN. WHERE BLOCKS ARE SHOWN OVER BEAMS FOR BUILDING UP TO THE SLAB, THE VERTICAL DIMENSIONS OF THE BLOCKS SHALL BE ADJUSTED BETWEEN BEARINGS TO COMPENSATE FOR DEAD LOAD DEFLECTIONS, VERTICAL CURVE ORDINATE, AND ACTUAL BEAM CAMBER. WHERE BOTTOM OF SLAB IS IN LINE WITH BOTTOM OF TOP FLANGES, DEPTH OF SLAB BETWEEN BEARINGS SHALL BE ADJUSTED TO COMPENSATE FOR DEAD LOAD DEFLECTION, VERTICAL CURVE ORDINATE, AND ACTUAL BEAM CAMBER.

IN SETTING FALSEWORK AND FORMS FOR REINFORCED CONCRETE SPANS, AN ALLOWANCE SHALL BE MADE FOR DEAD LOAD DEFLECTIONS, SETTLEMENT OF FALSEWORK, AND PERMANENT CAMBER WHICH SHALL BE PROVIDED FOR IN ADDITION TO THE ELEVATIONS SHOWN. AFTER REMOVAL OF THE FALSEWORK, THE FINISHED STRUCTURES SHALL CONFORM TO THE PROFILE AND ELEVATIONS SHOWN ON THE PLANS AND CONSTRUCTION ELEVATIONS FURNISHED BY THE ENGINEER.

DETAILED DRAWINGS FOR FALSEWORK OR FORMS FOR BRIDGE SUPERSTRUCTURE AND ANY STRUCTURE OR PARTS OF A STRUCTURE AS NOTED ON THE PLANS SHALL BE SUBMITTED TO THE ENGINEER FOR APPROVAL BEFORE CONSTRUCTION OF THE FALSEWORK OR FORMS IS STARTED.

REINFORCING STEEL:

ALL REINFORCING STEEL SHALL BE DEFORMED. DIMENSIONS RELATIVE TO PLACEMENT OF REINFORCING ARE TO CENTERS OF BARS UNLESS OTHERWISE INDICATED IN THE PLANS. DIMENSIONS ON BAR DETAILS ARE TO CENTERS OF BARS OR ARE OUT TO OUT AS INDICATED ON PLANS.

WIRE BAR SUPPORTS SHALL BE PROVIDED FOR REINFORCING STEEL WHERE INDICATED ON THE PLANS. WHEN BAR SUPPORT PIECES ARE PLACED IN CONTINUOUS LINES, THEY SHALL BE SO PLACED THAT THE ENDS OF THE SUPPORTING WIRES SHALL BE LAPPED TO LOCK LEGS ON ADJOINING PIECES.

STRUCTURAL STEEL:

AT THE CONTRACTOR'S OPTION, HE MAY SUBSTITUTE $\frac{7}{8}$ " \emptyset SHEAR STUDS FOR THE $\frac{3}{4}$ " \emptyset STUDS SPECIFIED ON THE PLANS. THIS SUBSTITUTION SHALL BE MADE AT THE RATE OF 3 - $\frac{7}{8}$ " \emptyset STUDS FOR 4 - $\frac{3}{4}$ " \emptyset STUDS, AND STUD SPACING CHANGES SHALL BE MADE AS NECESSARY TO PROVIDE THE SAME EQUIVALENT NUMBER OF $\frac{7}{8}$ " \emptyset STUDS ALONG THE BEAM AS SHOWN FOR $\frac{3}{4}$ " \emptyset STUDS BASED ON THE RATIO OF 3 - $\frac{7}{8}$ " \emptyset STUDS FOR 4 - $\frac{3}{4}$ " \emptyset STUDS. STUDS OF THE LENGTH SPECIFIED ON THE PLANS MUST BE PROVIDED. THE MAXIMUM SPACING SHALL BE 2'-0".

EXCEPT AT THE INTERIOR SUPPORTS OF CONTINUOUS BEAMS WHERE THE COVER PLATE IS IN CONTACT WITH BEARING PLATE, THE CONTRACTOR MAY, AT HIS OPTION, SUBSTITUTE FOR THE COVER PLATES DESIGNATED ON THE PLANS COVER PLATES OF THE EQUIVALENT AREA PROVIDED THESE PLATES ARE AT LEAST $\frac{3}{16}$ " IN THICKNESS AND DO NOT EXCEED A WIDTH EQUAL TO THE FLANGE WIDTH LESS 2" OR A THICKNESS EQUAL TO 2 TIMES THE FLANGE THICKNESS. THE SIZE OF FILLET WELDS SHALL CONFORM TO THE REQUIREMENTS OF THE CURRENT ANSI/AASHTO/AWS "BRIDGE WELDING CODE". ELECTROSLAG WELDING WILL NOT BE PERMITTED.

WITH THE SOLE EXCEPTION OF EDGES AT SURFACES WHICH BEAR ON OTHER SURFACES, ALL SHARP EDGES AND ENDS OF SHAPES AND PLATES SHALL BE SLIGHTLY ROUNDED BY SUITABLE MEANS TO A RADIUS OF APPROXIMATELY $\frac{1}{16}$ " INCH OR EQUIVALENT FLAT SURFACE AT A SUITABLE ANGLE PRIOR TO PAINTING, GALVANIZING, OR METALLIZING.

HANDRAILS AND POSTS:

METAL STANDARDS AND FACES OF THE CONCRETE END POSTS FOR THE METAL RAIL SHALL BE SET NORMAL TO THE GRADE OF THE CURB, UNLESS OTHERWISE SHOWN ON PLANS. THE METAL RAIL AND TOPS OF CONCRETE POSTS USED WITH THE ALUMINUM RAIL SHALL BE BUILT PARALLEL TO THE GRADE OF THE CURB.

METAL HANDRAILS SHALL BE IN ACCORDANCE WITH THE PLANS. RAILS SHALL BE AS MANUFACTURED FOR BRIDGE RAILING. CASTINGS SHALL BE OF A UNIFORM APPEARANCE. FINS AND OTHER DEFORMATIONS RESULTING FROM CASTING OR OTHERWISE SHALL BE REMOVED IN A MANNER SO THAT A UNIFORM COLORING OF THE COMPLETED CASTING SHALL BE OBTAINED. CASTINGS WITH DISCOLORATIONS OR OF NON-UNIFORM COLORING WILL NOT BE ACCEPTED. CERTIFIED MILL REPORTS ARE REQUIRED FOR METAL RAILS AND POSTS.

SPECIAL NOTES:

GENERALLY, IN CASE OF DISCREPANCY, THIS STANDARD SHEET OF NOTES SHALL GOVERN OVER THE SPECIFICATIONS, BUT THE REMAINDER OF THE PLANS SHALL GOVERN OVER NOTES HEREON, AND SPECIAL PROVISIONS SHALL GOVERN OVER ALL. SEE SPECIFICATIONS ARTICLE 105-4.

ENGLISH

JANUARY, 1990

STD. NO. SN