

EDI MODEL 2018ECLip-NC CONFLICT MONITOR PROGRAMMING DETAIL

(remove jumpers and set switches as shown)

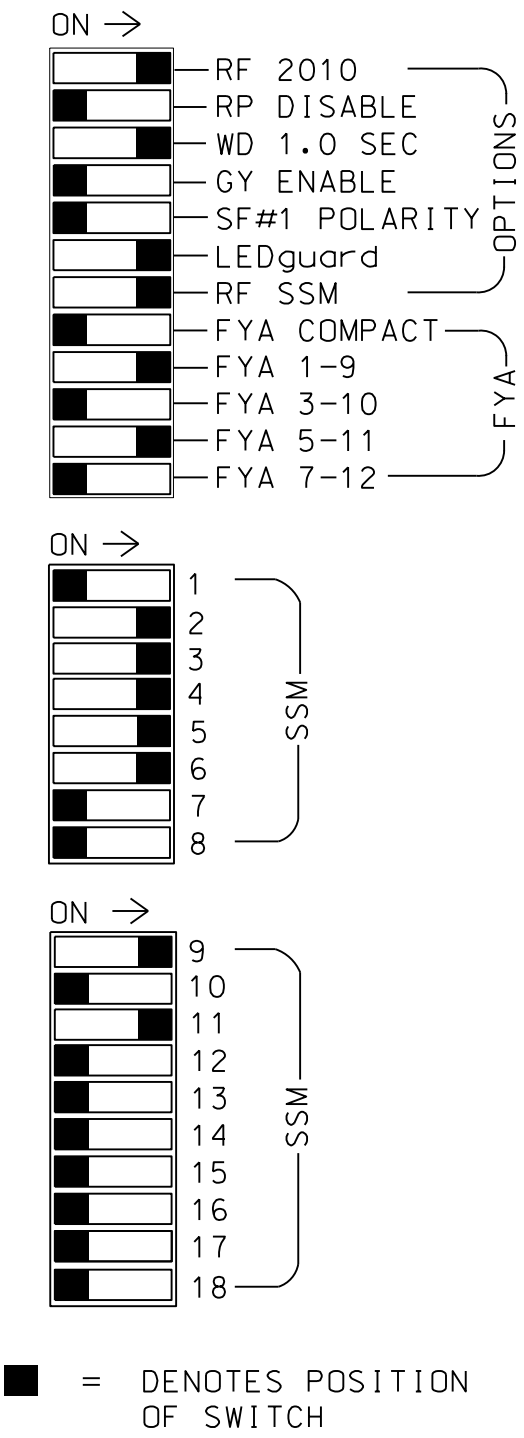
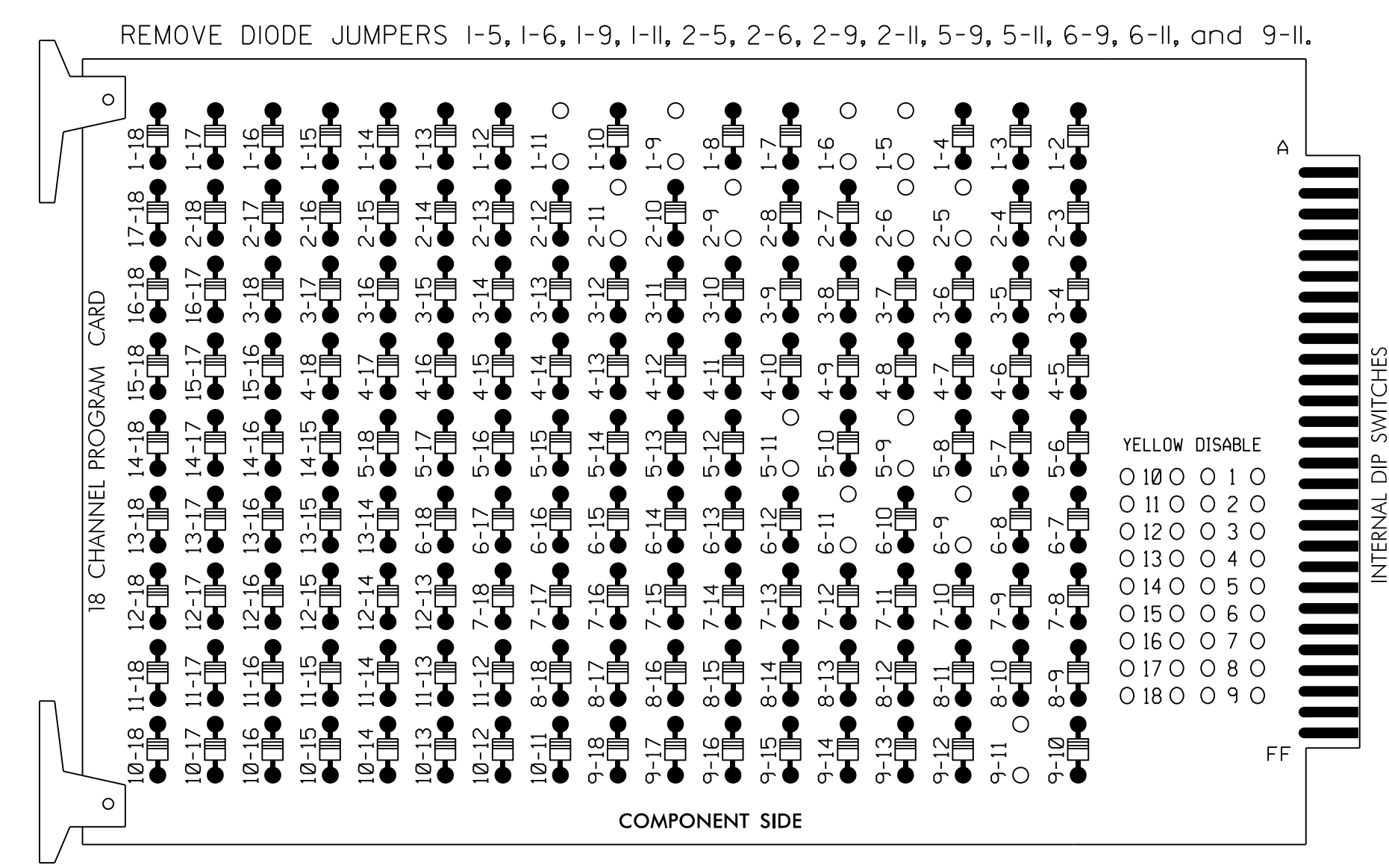

NOTES:

1. Card is provided with all diode jumpers in place. Removal of any jumper allows its channels to run concurrently.
2. Ensure jumpers SEL2-SEL5 and SEL9 are present on the monitor board.
3. Ensure that Red Enable is active at all times during normal operation.
4. Integrate monitor with Ethernet network in cabinet.

NOTES

1. To prevent "flash-conflict" problems, insert red flash program blocks for all unused vehicle load switches in the output file. The installer shall verify that signal heads flash in accordance with the Signal Plans.
2. Program controller to start up in Phase 2 Green and Phase 6 Green.
3. The cabinet and controller are part of the Fayetteville Signal System.

EQUIPMENT INFORMATION

CONTROLLER.....2070
 CABINET.....332 W/AUX
 SOFTWARE.....ECONOLITE ASC/3-2070
 CABINET MOUNT.....BASE
 OUTPUT FILE POSITIONS...18 WITH AUX. OUTPUT FILE
 LOAD SWITCHES USED.....S1,S2,S4,S5,S7,S8,
 AUX S1,AUX S4
 PHASES USED.....1,2,3,4,5,6
 OVERLAP A.....*
 OVERLAP B.....NOT USED
 OVERLAP C.....*
 OVERLAP D.....NOT USED
 * See Overlap Programming Detail on Sheet 2

SIGNAL HEAD HOOK-UP CHART

LOAD SWITCH NO.	S1	S2	S3	S4	S5	S6	S7	S8	S9	S10	S11	S12	AUX S1	AUX S2	AUX S3	AUX S4	AUX S5	AUX S6				
CMU CHANNEL NO.	1	2	13	3	4	14	5	6	15	7	8	16	9	10	17	11	12	18				
PHASE	1	2	2 PED	3	3	4	4	4 PED	5	4	6	6 PED	7	8	8 PED	OLA	OLB	SPARE	OLC	OLD	SPARE	
SIGNAL HEAD NO.	11*	21,22	NU	31	32	41	42	NU	51*	42	61,62	NU	NU	NU	NU	11*	NU	NU	51*	NU	NU	
RED		128		116	116	101	101		*		134											
YELLOW	*	129		117	117	102	102				135											
GREEN		130		118	118	103	103				136											
RED ARROW																A121				A114		
YELLOW ARROW											132					A122				A115		
FLASHING YELLOW ARROW																A123				A116		
GREEN ARROW	127			118		103					133	133										

NU = Not Used
 * Denotes install load resistor. See load resistor installation detail this sheet.
 * See pictorial of head wiring in detail below.

DETECTOR NOTES

1. For all loops install a video detection system for vehicle detection. Perform installation according to manufacturer's directions and NCDOT engineer-approved mounting locations to accomplish the detection schemes shown on the Signal Design Plans.
2. For loops 1A and 5A detector card placements and slots reserved for wired inputs are typical for a NCDOT installation. Inputs associated with these slots are compatible with time of day instructions located on sheet 2 of this electrical detail.

INPUT FILE POSITION LAYOUT

(front view)

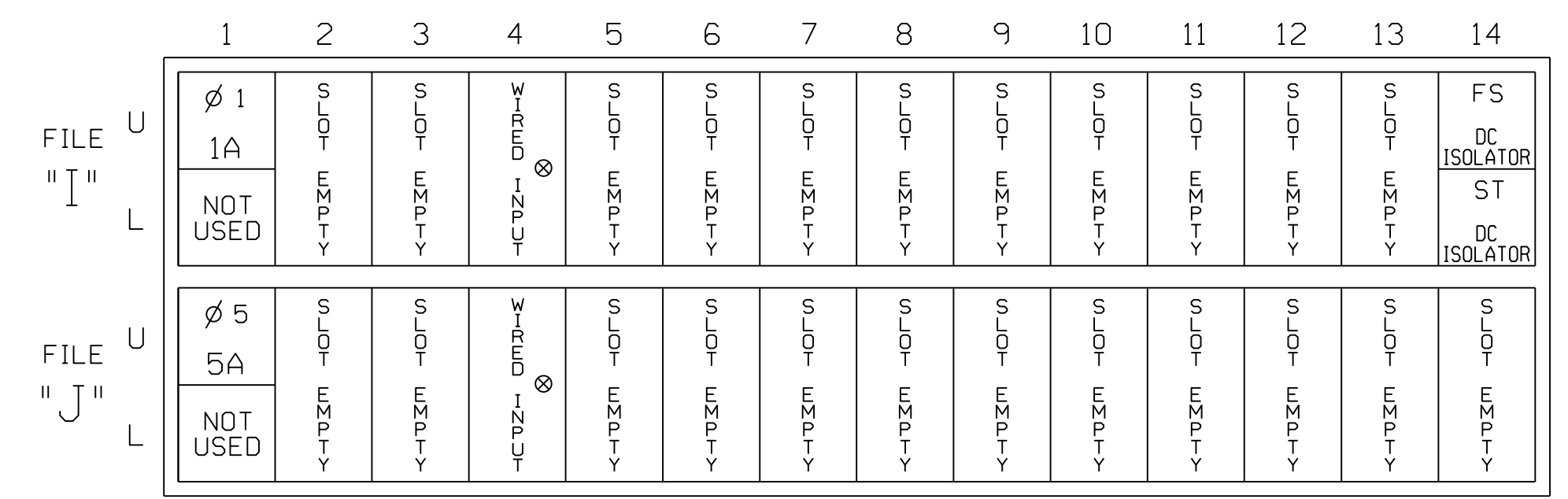

* Wired Input - Do not populate slot with detector card

INPUT FILE CONNECTION & PROGRAMMING CHART

LOOP NO.	LOOP TERMINAL	INPUT FILE POS.	PIN NO.	DETECTOR NO.	NEMA PHASE	CALL	EXTEND TIME	DELAY TIME	ADDED INITIAL	DETECTOR TYPE
1A ¹	-	I1U	56	1*	1	YES		15		S
	-	J4U	48	26*	6	YES				S
5A ²	-	J1U	55	5*	5	YES		15		S
	-	I4U	47	22*	2	YES				S

¹Add jumper from I1-W to J4-W, on rear of input file.
²Add jumper from J1-W to I4-W, on rear of input file.

* For the detectors to work as shown on the signal design plan, see the Vehicle Detector Setup Programming Detail for Alternate Phasing on sheet 2.

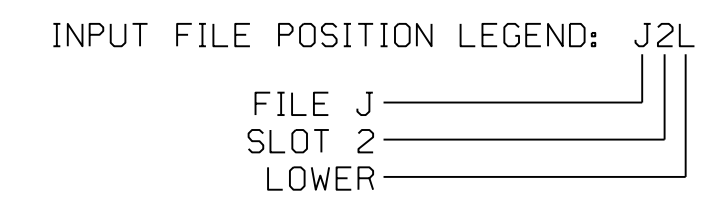

LOAD RESISTOR INSTALLATION DETAIL

(install resistors as shown)

ACCEPTABLE VALUES	
VALUE (ohms)	WATTAGE
1.5K - 1.9K	25W (min)
2.0K - 3.0K	10W (min)

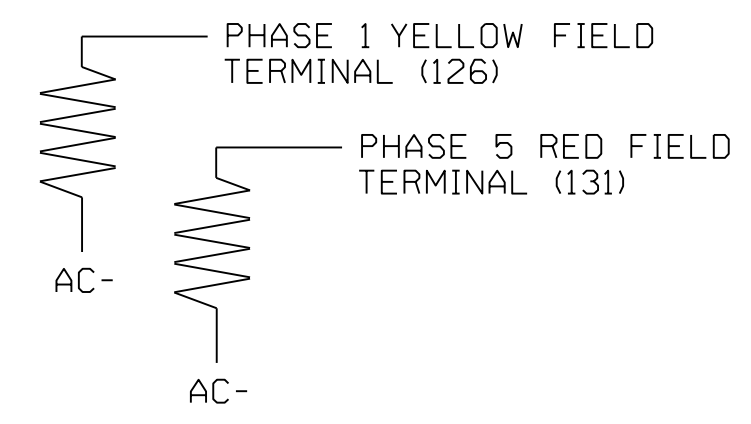

FYA SIGNAL WIRING DETAIL

(wire signal heads as shown)

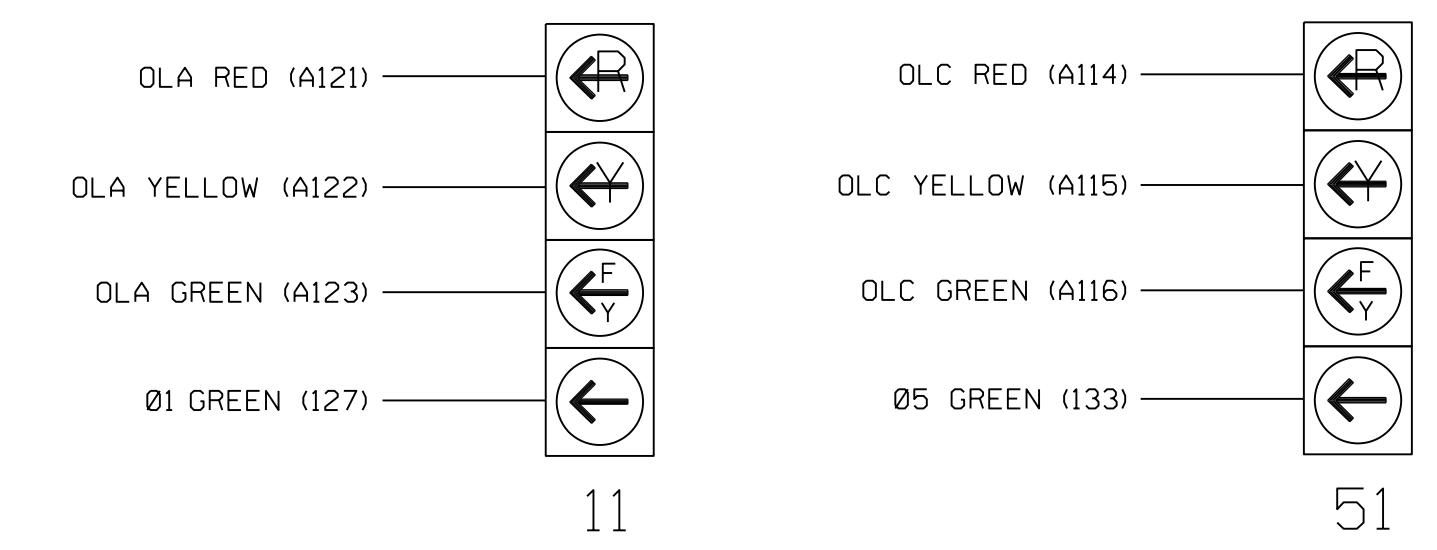

THIS ELECTRICAL DETAIL IS FOR THE SIGNAL DESIGN: 06-0001T2
 DESIGNED: March 2018
 SEALED: 03-29-2018
 REVISED: N/A

Temporary Design 2 - TMP Phase II
 Electrical Detail - Sheet 1 of 2

US 401 Business (Raeford Road)
 at
 Fairfield Road/
 United Methodist Church
 Division 6 Cumberland County Fayetteville

PLAN DATE: March 2018 REVIEWED BY: L Overn
 PREPARED BY: G B Spell REVIEWED BY:

REVISIONS	INIT.	DATE

SEAL
 NORTH CAROLINA
 PROFESSIONAL ENGINEER
 LAWRENCE E. OVERN
 045933
 3/29/2018
 DATE
 SIG. INVENTORY NO. 06-0001T2

DATE: U:\Projects\Signal\Temp\Detail\SignalPhase 2\U-4405.sig.ele.06-0001T2.dgn User: rrmuncey