

U-4405

TS-1

Cumberland County

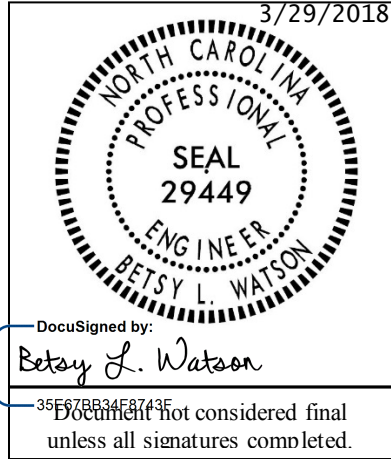

**Signals and Intelligent Transportation Systems  
Project Special Provisions  
(Version 18.1)**

Prepared By: EDH  
29-Mar-18

**Contents**

<b>1. 2018 STANDARD SPECIFICATIONS FOR ROADS &amp; STRUCTURES .....</b>	<b>4</b>
1.1. GENERAL REQUIREMENTS – CONSTRUCTION METHODS (1700-3(K)) .....	4
1.2. WOOD POLES – CONSTRUCTION METHODS (1720-3) .....	5
1.3. REQUIREMENTS FOR CABLES CROSSING RAILROADS .....	5
1.4. MEASUREMENT AND PAYMENT .....	8
<b>2. SIGNAL HEADS.....</b>	<b>8</b>
2.1. MATERIALS .....	8
A. General:.....	8
B. Vehicle Signal Heads:.....	9
C. Pedestrian Signal Heads:.....	12
D. Signal Cable:.....	14
<b>3. CONTROLLERS WITH CABINETS .....</b>	<b>14</b>
3.1. MATERIALS – GENERAL CABINETS .....	14
3.2. MATERIALS – TYPE 170E CABINETS .....	15
A. Type 170 E Cabinets General:.....	15
B. Type 170 E Cabinet Electrical Requirements:.....	16
C. Type 170 E Cabinet Physical Requirements:.....	23
D. Model 2018 Enhanced Conflict Monitor:.....	26
E. Preemption and Sign Control Box.....	36
3.3. MATERIALS – TYPE 2070LX CONTROLLERS .....	39
<b>4. VIDEO IMAGING LOOP EMULATOR DETECTOR SYSTEMS .....</b>	<b>39</b>
4.1. DESCRIPTION.....	39
4.2. MATERIALS .....	39
A. General:.....	39
B. Loop Emulator System:.....	41
C. Video Imaging Loop Emulator System Support:.....	42
4.3. CONSTRUCTION METHODS .....	43
4.4. MEASUREMENT AND PAYMENT .....	43
<b>5. TRAFFIC SIGNAL SUPPORTS .....</b>	<b>44</b>
5.1. METAL TRAFFIC SIGNAL SUPPORTS – ALL POLES .....	44
A. General:.....	44
B. Materials:.....	46
C. Construction Methods:.....	47
5.2. METAL POLE UPRIGHTS (VERTICAL MEMBERS) .....	48
A. Materials:.....	48
B. Construction Methods:.....	49

5.3.	DRILLED PIER FOUNDATIONS FOR METAL TRAFFIC SIGNAL POLES .....	49
A.	Description:.....	50
B.	Soil Test and Foundation Determination:.....	50
C.	Drilled Pier Construction:.....	53
5.4.	METAL SIGNAL POLE REMOVALS .....	53
A.	Description:.....	53
B.	Construction Methods:.....	53
5.5.	POLE NUMBERING SYSTEM .....	53
A.	New Poles.....	53
5.6.	MEASUREMENT AND PAYMENT .....	53
<b>6.</b>	<b>BACK PULL FIBER OPTIC CABLE.....</b>	<b>54</b>
6.1.	DESCRIPTION.....	54
6.2.	CONSTRUCTION .....	54
6.3.	MEASUREMENT AND PAYMENT .....	54
<b>7.</b>	<b>SPLICE CABINETS – FIBER OPTICS .....</b>	<b>54</b>
7.1.	FIBER-OPTIC SPLICE CABINET (BASE MOUNTED).....	54
A.	Description.....	54
B.	Materials.....	55
C.	Construction Methods.....	55
7.2.	HUB SPLICE CENTERS .....	55
A.	Description.....	55
B.	Materials.....	55
C.	Construction Methods.....	56
7.3.	MEASUREMENT AND PAYMENT .....	58
<b>8.</b>	<b>ETHERNET EDGE SWITCH.....</b>	<b>58</b>
8.1.	DESCRIPTION.....	58
A.	Ethernet Edge Switch:.....	58
B.	Network Management:.....	59
8.2.	MATERIALS .....	59
A.	General:.....	59
B.	Compatibility Acceptance.....	59
C.	Standards:.....	59
D.	Functional:.....	60
E.	Physical Features:.....	61
F.	Management Capabilities:.....	61
G.	Electrical Specifications:.....	63
H.	Environmental Specifications:.....	63
I.	Ethernet Patch Cable:.....	63
8.3.	CONSTRUCTION METHODS .....	64
A.	General:.....	64
B.	Edge Switch:.....	64
8.4.	MEASUREMENT AND PAYMENT .....	64
<b>9.</b>	<b>DMS ELECTRICAL SERVICE.....</b>	<b>64</b>
9.1.	DESCRIPTION.....	64
9.2.	MATERIALS .....	65
A.	Electrical Service.....	65
B.	Supplemental Equipment Cabinet Disconnect.....	66
C.	Grounding Electrodes (Ground Rods).....	66
9.3.	CONSTRUCTION METHODS .....	66
A.	General.....	66
B.	New Electrical Service for DMS .....	67
C.	Grounding of Electrical Services.....	67
9.4.	MEASUREMENT AND PAYMENT .....	68

<b>10. DIGITAL CCTV FIELD EQUIPMENT .....</b>	<b>68</b>
10.1. DESCRIPTION.....	68
10.2. MATERIAL.....	69
A. General.....	69
B. Camera and Lens.....	69
C. Camera Housing.....	70
D. Pan and Tilt Unit.....	70
E. Video Ethernet Encoder.....	71
F. Ethernet Cable.....	71
G. Control Receiver/Driver.....	71
H. CCTV Camera Attachment to Pole.....	72
I. Surge Suppression.....	72
10.3. CONSTRUCTION METHOD .....	72
A. General.....	72
B. Electrical and Mechanical Requirements.....	72
10.4. MEASUREMENT AND PAYMENT .....	73
<b>11. CCTV METAL POLES .....</b>	<b>73</b>
11.1. CCTVMETAL POLES .....	73
A. General:.....	73
11.2. MATERIALS:.....	75
11.3. CONSTRUCTION METHODS:.....	76
11.4. DRILLED PIER FOUNDATIONS FOR METAL POLES .....	77
A. Description:.....	77
B. Soil Test and Foundation Determination:.....	77
C. Non-Standard Foundation Design:.....	79
D. Drilled Pier Construction:.....	79
11.5. MEASUREMENT AND PAYMENT .....	79
<b>12. DYNAMIC MESSAGE SIGN (DMS) .....</b>	<b>79</b>
12.1. DESCRIPTION.....	79
12.2. MATERIALS .....	80
A. Environmental Requirements.....	80
B. Full Matrix Led Dynamic Message Sign (DMS).....	80
C. DMS Enclosure Structure Mounting.....	86
D. DMS / DMS Controller Interconnect.....	86
E. DMS Controller and Cabinet.....	86
F. Photo-Electric Sensors.....	94
G. Equipment List.....	94
H. Physical Description.....	94
I. Parts List.....	94
J. Character Set Submittal.....	95
K. Wiring Diagrams .....	95
L. Routine Of Operation.....	95
M. Maintenance Procedures.....	95
N. Repair Procedures.....	95
O. Field Trial.....	96
12.3. CONSTRUCTION METHODS .....	96
A. Description.....	96
B. Layout.....	96
C. Construction Submittal.....	96
D. Conduit.....	97
E. Wiring Methods.....	97
F. Equipment and Cabinet Mounting.....	97
G. Work Site Clean-Up.....	98
12.4. MEASUREMENT AND PAYMENT .....	98

<b>13. NTCIP Requirements .....</b>	<b>98</b>
13.1. REFERENCES.....	98
A. General Requirements.....	99
B. NTCIP Acceptance Testing.....	107
13.2. MEASUREMENT AND PAYMENT .....	108
<b>14. DMS ASSEMBLIES .....</b>	<b>108</b>
14.1. DESCRIPTION.....	108
14.2. MATERIAL.....	108
14.3. CONSTRUCTION METHODS .....	109
A. General.....	109
B. Shop Drawing.....	109
C. Design and Fabrication.....	110
14.4. MEASUREMENT AND PAYMENT .....	112
<b>15. SOIL TEST FOR DMS FOUNDATION.....</b>	<b>112</b>
15.1. DESCRIPTION.....	112
15.2. SOIL TEST .....	113
A. General.....	113
B. Soil Test.....	113
15.3. MEASUREMENT AND PAYMENT .....	114
<b>16. FOUNDATIONS AND ANCHOR ROD ASSEMBLIES FOR METAL POLES .....</b>	<b>114</b>
16.1. DESCRIPTION.....	114
16.2. MATERIALS .....	114
16.3. CONSTRUCTION METHODS .....	115
A. Drilled Piers .....	115
B. Footings, Pedestals, Grade Beams, and Wings.....	117
C. Anchor Rod Assemblies .....	117
16.4. MEASUREMENT AND PAYMENT .....	119
<b>17. DYNAMIC MESSAGE SIGN FOUNDATIONS .....</b>	<b>119</b>
17.1. DESCRIPTION.....	119
17.2. MATERIALS .....	120
A. Assumed Subsurface Conditions.....	120
B. Subsurface Investigations.....	120
C. Sign Foundation Designs .....	120
17.3. CONSTRUCTION METHODS .....	121
17.4. MEASUREMENT AND PAYMENT .....	121

## 1. 2018 STANDARD SPECIFICATIONS FOR ROADS & STRUCTURES

*The 2018 Standard Specifications are revised as follows:*

### 1.1. GENERAL REQUIREMENTS – Construction Methods (1700-3(K))

Page 17-4, revise sentence starting on line 14 to read “Modify existing electrical services, as necessary, to meet the grounding requirements of the NEC, these *Standard Specifications*, *Standard Drawings*, and the project plans.”

Page 17-4, revise sentence beginning on line 21 to read “Furnish and install additional ground rods to grounding electrode system as necessary to meet the *Standard Specifications*, *Standard Drawings*, and test requirements.”

U-4405

TS-5

Cumberland County

**1.2. WOOD POLES – Construction Methods (1720-3)**

Page 17-18, revise sentence starting on line 13 to read “On new Department-owned poles, install a grounding system consisting of #6 AWG solid bare copper wire that is mechanically crimped using an irreversible compression tool with die to a single ground rod installed at base of pole or to the electrical service grounding electrode system located within 10 feet of the pole.”

**1.3. REQUIREMENTS FOR CABLES CROSSING RAILROADS**

Copies of all executed railroad agreements and related correspondence may be obtained from the Engineer upon request.

**1. Railroad Crossings**

Application has been made with Aberdeen & Rockfish herein called the Railroad Company, for the encroachment agreements necessary under this Contract. Do not commence cable routing work over or under railroad-owned facilities until notification and coordination with Engineer and the appropriate Railroad Company has occurred. Install fiber-optic communications cable as shown on the Plans. All work associated with the crossing is to conform to the Railroad Company’s specifications.

For work within Aberdeen & Rockfish’s rights of way, comply with the latest approved edition of Railroad Specification CE-4, “Specifications for Wire, Conduit and Cable Occupations of Railroad Property” and Railroad Specification CE-8 “Specifications for Pipeline Occupancy of Railroad Property.”

Cable crossings include the following location(s):

<b>Plan Sheet</b>	<b>Location</b>	<b>Railroad Company</b>
SCP-17	At-Grade Crossing across US 401 (Raeford Road) at Twin Acres Drive near Owen Drive/ Crossing AAR# 847-200B	Aberdeen & Rockfish

**2. Insurance Requirements**

The Department has provided Railroad Protective Liability Insurance to the railroad company as part of the Department’s encroachment agreements with the railroad companies for each of location listed in the table above.

If required by the railroad, pay for railroad personnel to be present when work is performed.

In addition to any other forms of insurance or bonds required under the terms of the Contract and the *Standard Specifications*, take out and keep in force from the commencement of all construction on railroad right-of-way until the final inspection and acceptance of the project by the Engineer, insurance of the following kinds and amount. It is understood that the amounts specified are minimum amounts and that larger amounts may be carried if so desired. Any insurance taken out due to these requirements shall be subject to the approval of the Engineer, and the Railroad Company as to form and amount. Furnish satisfactory policies for approval prior to beginning of any work on railroad right-of-way.

Refer to the below verbiage for more specific insurance requirements and requirements for working on the rights-of-way of the railroad company. In the event of a conflict between the

**U-4405****TS-6****Cumberland County**

requirements of the railroad company and the requirements contained in the Plans or these Project Special Provisions, the requirements of the railroad company shall govern.

- (a) Statutory Workers' Compensation and Employer's Liability insurance.
- (b) An Occurrence Form Railroad Protective Policy with limits of not less than Two Million (\$2,000,000.00) Dollars per occurrence for Bodily Injury Liability, Property Damage Liability and Physical Damage to Property, with Six Million (\$6,000,000.00) Dollars aggregate for the term of the policy with respect to Bodily Injury, Liability, Property Damage Liability and Physical Damage to Property. The Policy must name

**ABERDEEN & ROCKFISH RAILROAD COMPANY  
101 E. MAIN ST.  
P.O. BOX 917  
ABERDEEN, NC 28315**

as the insured, and shall provide for not less than ten (10) days' prior written notice to Railroad of cancellation of, or any material change, in the policy.

Keep such insurance in force until final inspection of the project, or that portion or portions within the railroad right-of-way, by the Engineer or, in the case of Subcontractors, until the Contractor furnishes a letter to the Engineer stating that the Subcontractor has completed his/her subcontracted work within the railroad right-of-way to Contractor's satisfaction, and that the Contractor will accomplish any additional work necessary on the railroad right-of-way with the Contractor's own forces.

#### **Termination of Insurance and Policies to be Submitted**

Any insurance policies given hereunder shall cover all Contractor-performed work within railroad right-of-way, but shall not be liable for accidents occurring after acceptance of the completed project by the Department. Such policies shall contain a clause requiring 30 days written notice be given to the Engineer and to the appropriate Railroad Company, prior to cancellation or change.

Submit to the Engineer the original and one copy of the Commercial General Liability Policy, one certified duplicate copy of all other policies, and certificates of insurance in an original and two copies as required by these Project Special Provisions.

No extra allowance will be made for the insurance required hereunder. The entire cost shall be included in the contract unit price bids for other pay items.

The named insured under the commercial General Liability Insurance Policy is the respective Railroad Company, and the designation of the job site description of work is as follows: All construction on the Aberdeen & Rockfish right-of-way on NCDOT Project No. U-4405 in the City of Fayetteville, Cumberland County, North Carolina.

### **3. Flagging Protection or Watchman Service**

Provide a minimum of 7 days advance notice to Aberdeen & Rockfish in order that flagging service can be arranged and provided. Do not undertake any work within the Aberdeen & Rockfish right-of-way until the flagman is at the job site.

**4. Delays Caused by Operations of Others**

Neither the Department nor the Railroad Company assumes any responsibility for any work performed by others in connection with the construction of the project, and the Contractor shall have no claim whatsoever against the Department or the Railroad Company for any inconvenience, delay, or additional cost incurred by the Contractor on account of such operations by others.

**5. Time Extensions**

No time extensions related to railroad encroachments will be allowed until the related work becomes the controlling factor relative to overall project completion.

**6. Cooperation with Others**

Cooperate with others participating in the construction of the project to the end that all work may be carried on to the best advantage.

**7. Authority of Railroad Engineer**

The authorized representative of the Railroad Company, hereinafter referred to as the Railroad Engineer, will have the final authority in all matters affecting the safe maintenance of railroad traffic of his company.

**8. Interference with Railroad Operations**

Arrange and conduct work so that there will be no interference with railroad operations, including train, signal, telephone and telegraphic services, or damage to the property of the Railroad Company or to the poles, wire, and other facilities of tenants on the rights-of-way of the Railroad Company. Wherever work is liable to affect the operations or safety of trains, first submit the method of doing such work to the Railroad Engineer for approval. However, such approval will not relieve the Contractor from liability.

Should conditions arising from or in connection with the work, require that immediate and unusual provisions be made to protect train operations and property of the Railroad Company, it shall be a part of the required services by the Contractor to make such provisions and if, in the judgment of the Railroad Engineer such provisions are insufficient, the Railroad Engineer or the Department may, at the expense of the Contractor, require or provide such provisions as may be deemed necessary.

**9. Storage of Materials**

Do not store materials and equipment where they will interfere with railroad operations, nor on the rights-of-way of the Railroad Company without first having obtained permission from the Railroad Engineer. Such permission will be with the understanding that the Railroad Company will not be liable or damage to such material and equipment from any cause, and that the Railroad Engineer may move or require the Contractor to move, at the Contractor's expense, such material and equipment.

**10. Completion and Acceptance of Work**

Upon completion of the work, remove from within the limits of the railroad right-of-way all machinery, equipment, surplus materials, or rubbish and leave said rights-of-way in a neat and orderly condition. Acceptance of the work will be contingent upon final inspection by the Department and by the Railroad Company (if required by the Railroad Company) to determine if the work was completed satisfactorily in a manner acceptable to the Department and the Railroad Company.

U-4405

TS-8

Cumberland County

#### 1.4. MEASUREMENT AND PAYMENT

There will be no direct payment for work covered in this section. Include the costs for obtaining and furnishing Railroad insurance whose measurement and payment is not specifically stated under any of the contract pay items, into the unit cost(s) for the various contract pay items associated with performing this work.

### 2. SIGNAL HEADS

#### 2.1. MATERIALS

##### A. General:

Fabricate vehicle signal head housings, 16-inch pedestrian signal head housings, and end caps from die-cast aluminum. Provide visor mounting screws, door latches, and hinge pins fabricated from stainless steel. Provide interior screws, fasteners, and metal parts fabricated from stainless steel.

Fabricate tunnel and traditional visors from sheet aluminum.

Paint all surfaces inside and outside of signal housings and doors. Paint outside surfaces of tunnel and traditional visors, wire outlet bodies, wire entrance fitting brackets and end caps when supplied as components of messenger cable mounting assemblies, pole and pedestal mounting assemblies, and pedestrian pushbutton housings. Have electrostatically-applied, fused-polyester paint in highway yellow (Federal Standard 595C, Color Chip Number 13538) a minimum of 2.5 to 3.5 mils thick. Do not apply paint to the latching hardware, rigid vehicle signal head mounting brackets for mast-arm attachments, messenger cable hanger components or balance adjuster components.

Have the interior surfaces of tunnel and traditional visors painted an alkyd urea black synthetic baking enamel with a minimum gloss reflectance and meeting the requirements of MIL-E-10169, "Enamel Heat Resisting, Instrument Black."

Where required, provide polycarbonate signal heads and visors that comply with the provisions pertaining to the aluminum signal heads listed on the QPL with the following exceptions:

Fabricate signal head housings, end caps, and visors from virgin polycarbonate material. Provide UV stabilized polycarbonate plastic with a minimum thickness of  $0.1 \pm 0.01$  inches that is highway yellow (Federal Standard 595C, Color Chip 13538). Ensure the color is incorporated into the plastic material before molding the signal head housings and end caps. Ensure the plastic formulation provides the following physical properties in the assembly (tests may be performed on separately molded specimens):

Test	Required	Method
Specific Gravity	1.17 minimum	ASTM D 792
Flammability	Self-extinguishing	ASTM D 635
Tensile Strength, yield, PSI	8500 minimum	ASTM D 638
Izod impact strength, ft-lb/in [notched, 1/8 inch]	12 minimum	ASTM D 256

For pedestal mounting, provide a post-top slipfitter mounting assembly that matches the positive locking device on the signal head with serrations integrally cast into the slipfitter. Provide stainless



**U-4405****TS-9****Cumberland County**

steel hardware, screws, washers, etc. Provide a minimum of six 3/8 X 3/4-inch long square head bolts for attachment to pedestal. Provide a center post for multi-way slipfitters.

For light emitting diode (LED) traffic signal modules, provide the following requirements for inclusion on the Department's Qualified Products List for traffic signal equipment.

1. Sample submittal,
2. Third-party independent laboratory testing results for each submitted module with evidence of testing and conformance with all of the Design Qualification Testing specified in section 6.4 of each of the following Institute of Transportation Engineers (ITE) specifications:
  - Vehicle Traffic Control Signal Heads – Light Emitting Diode (LED) Circular Signal Supplement
  - Vehicle Traffic Control Signal Heads – Light Emitting Diode (LED) Vehicle Arrow Traffic Signal Supplement
  - Pedestrian Traffic Control Signal Indications –Light Emitting Diode (LED) Signal Modules.

(Note: The Department currently recognizes two approved independent testing laboratories. They are Intertek ETL Semko and Light Metrics, Incorporated with Garwood Laboratories. Independent laboratory tests from other laboratories may be considered as part of the QPL submittal at the discretion of the Department,

3. Evidence of conformance with the requirements of these specifications,
4. A manufacturer's warranty statement in accordance with the required warranty, and
5. Submittal of manufacturer's design and production documentation for the model, including but not limited to, electrical schematics, electronic component values, proprietary part numbers, bill of materials, and production electrical and photometric test parameters.
6. Evidence of approval of the product to bear the Intertek ETL Verified product label for LED traffic signal modules.

In addition to meeting the performance requirements for the minimum period of 60 months, provide a written warranty against defects in materials and workmanship for the modules for a period of 60 months after installation of the modules. During the warranty period, the manufacturer must provide new replacement modules within 45 days of receipt of modules that have failed at no cost to the State. Repaired or refurbished modules may not be used to fulfill the manufacturer's warranty obligations. Provide manufacturer's warranty documentation to the Department during evaluation of product for inclusion on Qualified Products List (QPL).

### **B. Vehicle Signal Heads:**

Comply with the ITE standard "Vehicle Traffic Control Signal Heads". Provide housings with provisions for attaching backplates.

Provide visors that are 8 inches in length for 8-inch vehicle signal head sections. Provide visors that are 10 inches in length for 12-inch vehicle signal heads.

**U-4405****TS-10****Cumberland County**

Provide a termination block with one empty terminal for field wiring for each indication plus one empty terminal for the neutral conductor. Have all signal sections wired to the termination block. Provide barriers between the terminals that have terminal screws with a minimum Number 8 thread size and that will accommodate, and secure spade lugs sized for a Number 10 terminal screw.

Mount termination blocks in the yellow signal head sections on all in-line vehicle signal heads. Mount the termination block in the red section on five-section vehicle signal heads.

Furnish vehicle signal head interconnecting brackets. Provide one-piece aluminum brackets less than 4.5 inches in height and with no threaded pipe connections. Provide hand holes on the bottom of the brackets to aid in installing wires to the signal heads. Lower brackets that carry no wires and are used only for connecting the bottom signal sections together may be flat in construction.

For messenger cable mounting, provide messenger cable hangers, wire outlet bodies, balance adjusters, bottom caps, wire entrance fitting brackets, and all other hardware necessary to make complete, watertight connections of the vehicle signal heads to the messenger cable. Fabricate messenger cable hanger components, wire outlet bodies and balance adjuster components from stainless steel or malleable iron galvanized in accordance with ASTM A153 (Class A) or ASTM A123. Provide serrated rings made of aluminum. Provide messenger cable hangers with U-bolt clamps. Fabricate washers, screws, hex-head bolts and associated nuts, clevis pins, cotter pins, U-bolt clamps and nuts from stainless steel.

Provide LED vehicular traffic signal modules (hereafter referred to as modules) that consist of an assembly that uses LEDs as the light source in lieu of an incandescent lamp for use in traffic signal sections. Use LEDs that are aluminum indium gallium phosphorus (AlInGaP) technology for red and yellow indications and indium gallium nitride (InGaN) for green indications. Install the ultra-bright type LEDs that are rated for 100,000 hours of continuous operation from -40°F to +165°F. Design modules to have a minimum useful life of 60 months and to meet all parameters of this specification during this period of useful life.

For the modules, provide spade terminals crimped to the lead wires and sized for a #10 screw connection to the existing terminal block in a standard signal head. Do not provide other types of crimped terminals with a spade adapter.

Ensure the power supply is integral to the module assembly. On the back of the module, permanently mark the date of manufacture (month & year) or some other method of identifying date of manufacture.

Tint the red, yellow, and green lenses to correspond with the wavelength (chromaticity) of the LED. Transparent tinting films are unacceptable. Provide a lens that is integral to the unit with a smooth outer surface.

#### **1. LED Circular Signal Modules:**

Provide modules in the following configurations: 12-inch circular sections, and 8-inch circular sections. All makes, and models of LED modules purchased for use on the State Highway System shall appear on the current NCDOT Traffic Signal Qualified Products List (QPL).

Provide the manufacturer's model number and the product number (assigned by the Department) for each module that appears on the 2018 or most recent Qualified Products List. In addition, provide manufacturer's certification in accordance with Article 106-3 of the *Standard Specifications*, that each module meets or exceeds the ITE "Vehicle Traffic Control Signal Heads – Light Emitting

U-4405

**TS-11**

Cumberland County

Diode (LED) Circular Signal Supplement” dated June 27, 2005 (hereafter referred to as VTCSH Circular Supplement) and other requirements stated in this specification.

Provide modules that meet the following requirements when tested under the procedures outlined in the VTCSH Circular Supplement:

Module Type	Max. Wattage at 165° F	Nominal Wattage at 77° F
12-inch red circular	17	11
8-inch red circular	13	8
12-inch green circular	15	15
8-inch green circular	12	12

For yellow circular signal modules, provide modules tested under the procedures outlined in the VTCSH Circular Supplement to insure power required at 77° F is 22 Watts or less for the 12-inch circular module.

Note: Use a wattmeter having an accuracy of  $\pm 1\%$  to measure the nominal wattage and maximum wattage of a circular traffic signal module. Power may also be derived from voltage, current and power factor measurements.

## 2. LED Arrow Signal Modules

Provide 12-inch omnidirectional arrow signal modules. All makes, and models of LED modules purchased for use on the State Highway System shall appear on the current NCDOT Traffic Signal Qualified Products List (QPL).

Provide the manufacturer’s model number and the product number (assigned by the Department) for each module that appears on the 2018 or most recent Qualified Products List. In addition, provide manufacturer’s certification in accordance with Article 106-3 of the *Standard Specifications*, that each module meets or exceeds the requirements for 12-inch omnidirectional modules specified in the ITE “Vehicle Traffic Control Signal Heads – Light Emitting Diode (LED) Vehicle Arrow Traffic Signal Supplement” dated July 1, 2007 (hereafter referred to as VTCSH Arrow Supplement) and other requirements stated in this specification.

Provide modules that meet the following requirements when tested under the procedures outlined in the VTCSH Arrow Supplement:

Module Type	Max. Wattage at 165° F	Nominal Wattage at 77° F
12-inch red arrow	12	9
12-inch green arrow	11	11

For yellow arrow signal modules, provide modules tested under the procedures outlined in the VTCSH Arrow Supplement to insure power required at 77° F is 12 Watts or less.

Note: Use a wattmeter having an accuracy of  $\pm 1\%$  to measure the nominal wattage and maximum wattage of an arrow traffic signal module. Power may also be derived from voltage, current and power factor measurements.

### 3. LED U-Turn Arrow Signal Modules:

Provide modules in the following configurations: 12-inch left u-turn arrow signal modules and 12-inch right u-turn arrow signal modules.

Modules are not required to be listed on the ITS and Signals Qualified Products List. Provide manufacturer's certification in accordance with Article 106-3 of the *Standard Specifications*, that each module meets or exceeds the ITE "Vehicle Traffic Control Signal Heads – Light Emitting Diode (LED) Circular Signal Supplement" dated June 27, 2005 (hereafter referred to as VTCSH Circular Supplement) and other requirements stated in this specification.

Provide modules that have minimum maintained luminous intensity values that are not less than 16% of the values calculated using the method described in section 4.1 of the VTCSH Circular Supplement.

Provide modules that meet the following requirements when tested under the procedures outlined in the VTCSH Circular Supplement:

Module Type	Max. Wattage at 165° F	Nominal Wattage at 77° F
12-inch red u-turn arrow	17	11
12-inch green u-turn arrow	15	15

For yellow u-turn arrow signal modules, provide modules tested under the procedures outlined in the VTCSH Circular Supplement to ensure power required at 77° F is 22 Watts or less.

Note: Use a wattmeter having an accuracy of  $\pm 1\%$  to measure the nominal wattage and maximum wattage of a circular traffic signal module. Power may also be derived from voltage, current and power factor measurements.

### C. Pedestrian Signal Heads:

Provide pedestrian signal heads with international symbols that meet the MUTCD. Do not provide letter indications.

Comply with the ITE standard for "Pedestrian Traffic Control Signal Indications" and the following sections of the ITE standard for "Vehicle Traffic Control Signal Heads" in effect on the date of advertisement:

- Section 3.00 - "Physical and Mechanical Requirements"
- Section 4.01 - "Housing, Door, and Visor: General"
- Section 4.04 - "Housing, Door, and Visor: Materials and Fabrication"
- Section 7.00 - "Exterior Finish"

Provide a double-row termination block with three empty terminals and number 10 screws for field wiring. Provide barriers between the terminals that accommodate a spade lug sized for number 10 terminal screws. Mount the termination block in the hand section. Wire all signal sections to the terminal block.

Where required by the plans, provide 16-inch pedestrian signal heads with traditional three-sided, rectangular visors, 6 inches long. Where required by the plans, provide 12-inch pedestrian signal heads with traditional three-sided, rectangular visors, 8 inches long.

**U-4405****TS-13****Cumberland County**

Provide 2-inch diameter pedestrian push-buttons with weather-tight housings fabricated from die-cast aluminum and threading in compliance with the NEC for rigid metal conduit. Provide a weep hole in the housing bottom and ensure that the unit is vandal resistant.

Provide push-button housings that are suitable for mounting on flat or curved surfaces and that will accept 1/2-inch conduit installed in the top. Provide units that have a heavy duty push-button assembly with a sturdy, momentary, normally-open switch. Have contacts that are electrically insulated from the housing and push-button. Ensure that the push-buttons are rated for a minimum of 5 mA at 24 volts DC and 250 mA at 12 volts AC.

Provide standard R10-3 signs with mounting hardware that comply with the MUTCD in effect on the date of advertisement. Provide R10-3E signs for countdown pedestrian heads and R10-3B for non-countdown pedestrian heads.

Design the LED pedestrian traffic signal modules (hereafter referred to as modules) for installation into standard pedestrian traffic signal sections that do not contain the incandescent signal section reflector, lens, eggcrate visor, gasket, or socket. Provide modules that consist of an assembly that uses LEDs as the light source in lieu of an incandescent lamp. Use LEDs that are of the latest aluminum indium gallium phosphorus (AlInGaP) technology for the Portland Orange hand and countdown displays. Use LEDs that are of the latest indium gallium nitride (InGaN) technology for the Lunar White walking man displays. Install the ultra-bright type LEDs that are rated for 100,000 hours of continuous operation from -40°F to +165°F. Design modules to have a minimum useful life of 60 months and to meet all parameters of this specification during this period of useful life.

Design all modules to operate using a standard 3 - wire field installation. Provide spade terminals crimped to the lead wires and sized for a #10 screw connection to the existing terminal block in a standard pedestrian signal housing. Do not provide other types of crimped terminals with a spade adapter.

Ensure the power supply is integral to the module assembly. On the back of the module, permanently mark the date of manufacture (month & year) or some other method of identifying date of manufacture.

Provide modules in the following configuration: 16-inch displays which have the solid hand/walking man overlay on the left and the countdown on the right, and 12-inch displays which have the solid hand/walking man module as an overlay. All makes, and models of LED modules purchased for use on the State Highway System shall appear on the current NCDOT Traffic Signal Qualified Products List (QPL).

Provide the manufacturer's model number and the product number (assigned by the Department) for each module that appears on the 2018 or most recent Qualified Products List. In addition, provide manufacturer's certification in accordance with Article 106-3 of the *Standard Specifications*, that each module meets or exceeds the ITE "Pedestrian Traffic Control Signal Indicators - Light Emitting Diode (LED) Signal Modules" dated August 04, 2010 (hereafter referred to as PTCSI Pedestrian Standard) and other requirements stated in this specification.

U-4405

TS-14

Cumberland County

Provide modules that meet the following requirements when tested under the procedures outlined in the PTCSI Pedestrian Standard:

Module Type	Max. Wattage at 165° F	Nominal Wattage at 77° F
Hand Indication	16	13
Walking Man Indication	12	9
Countdown Indication	16	13

Note: Use a wattmeter having an accuracy of  $\pm 1\%$  to measure the nominal wattage and maximum wattage of a circular traffic signal module. Power may also be derived from voltage, current and power factor measurements.

Provide module lens that is hard coated or otherwise made to comply with the material exposure and weathering effects requirements of the Society of Automotive Engineers (SAE) J576. Ensure all exposed components of the module are suitable for prolonged exposure to the environment, without appreciable degradation that would interfere with function or appearance.

Ensure the countdown display continuously monitors the traffic controller to automatically learn the pedestrian phase time and update for subsequent changes to the pedestrian phase time.

Ensure the countdown display begins normal operation upon the completion of the preemption sequence and no more than one pedestrian clearance cycle.

#### **D. Signal Cable:**

Furnish 16-4 and 16-7 signal cable that complies with IMSA specification 20-1 except provide the following conductor insulation colors:

- For 16-4 cable: white, yellow, red, and green
- For 16-7 cable: white, yellow, red, green, yellow with black stripe tracer, red with black stripe tracer, and green with black stripe tracer. Apply continuous stripe tracer on conductor insulation with a longitudinal or spiral pattern.

Provide a ripcord to allow the cable jacket to be opened without using a cutter. IMSA specification 19-1 will not be acceptable. Provide a cable jacket labeled with the IMSA specification number and provide conductors constructed of stranded copper.

### **3. CONTROLLERS WITH CABINETS**

#### **3.1. MATERIALS – GENERAL CABINETS**

**Install an Ethernet edge switch in all new cabinets and furnish an Ethernet edge switch for each spare cabinet. See Section 9 - ETHERNET EDGE SWITCH.**

Provide a moisture resistant coating on all circuit boards.

Provide one 20 mm diameter radial lead UL-recognized metal oxide varistor (MOV) between each load switch field terminal and equipment ground. Electrical performance is outlined below.

PROPERTIES OF MOV SURGE PROTECTOR	
Maximum Continuous Applied Voltage at 185° F	150 VAC (RMS) 200 VDC
Maximum Peak 8x20µs Current at 185° F	6500 A
Maximum Energy Rating at 185° F	80 J
Voltage Range 1 mA DC Test at 77° F	212-268 V
Max. Clamping Voltage 8x20µs, 100A at 77° F	395 V
Typical Capacitance (1 MHz) at 77° F	1600 pF

Provide a power line surge protector that is a two-stage device that will allow connection of the radio frequency interference filter between the stages of the device. Ensure that a maximum continuous current is at least 10A at 120V. Ensure that the device can withstand a minimum of 20 peak surge current occurrences at 20,000A for an 8x20 microsecond waveform. Provide a maximum clamp voltage of 395V at 20,000A with a nominal series inductance of 200µh. Ensure that the voltage does not exceed 395V. Provide devices that comply with the following:

Frequency (Hz)	Minimum Insertion Loss (dB)
60	0
10,000	30
50,000	55
100,000	50
500,000	50
2,000,000	60
5,000,000	40
10,000,000	20
20,000,000	25

### 3.2. MATERIALS – TYPE 170E CABINETS

#### A. Type 170 E Cabinets General:

Conform to the city of Los Angeles' Specification No. 54-053-08, *Traffic Signal Cabinet Assembly Specification* (dated July 2008), except as required herein.

Furnish model 336S pole mounted cabinets configured for 8 vehicle phases, 4 pedestrian phases, and 6 overlaps. Do not reassign load switches to accommodate overlaps unless shown on electrical

**U-4405****TS-16****Cumberland County**

details. Provide 336S pole mounted cabinets that are 46" high with 40" high internal rack assemblies.

Furnish model 332 base mounted cabinets configured for 8 vehicle phases, 4 pedestrian phases, and 6 overlaps. When overlaps are required, provide auxiliary output files for the overlaps. Do not reassign load switches to accommodate overlaps unless shown on electrical details.

Provide model 200 load switches, model 222 loop detector sensors, model 252 AC isolators, and model 242 DC isolators according to the electrical details. As a minimum, provide one (1) model 2018 conflict monitor, one (1) model 206L power supply unit, two (2) model 204 flashers, one (1) DC isolator (located in slot I14), and four (4) model 430 flash transfer relays (provide seven (7) model 430 flash transfer relays if auxiliary output file is installed) with each cabinet.

### **B. Type 170 E Cabinet Electrical Requirements:**

Provide a cabinet assembly designed to ensure that upon leaving any cabinet switch or conflict monitor initiated flashing operation, the controller starts up in the programmed start up phases and start up interval.

Furnish two sets of non-fading cabinet wiring diagrams and schematics in a paper envelope or container and placed in the cabinet drawer.

All AC+ power is subject to radio frequency signal suppression.

Provide surge suppression in the cabinet for each type of cabinet device. Provide surge protection for the full capacity of the cabinet input file. Provide surge suppression devices that operate properly over a temperature range of -40° F to +185° F. Ensure the surge suppression devices provide both common and differential modes of protection.

Provide a pluggable power line surge protector that is installed on the back of the PDA (power distribution assembly) chassis to filter and absorb power line noise and switching transients. Ensure the device incorporates LEDs for failure indication and provides a dry relay contact closure for the purpose of remote sensing. Ensure the device meets the following specifications:

Peak Surge Current (Single pulse, 8x20µs).....	20,000A
Occurrences (8x20µs waveform).....	10 minimum @ 20,000A
Maximum Clamp Voltage .....	395VAC
Operating Current.....	15 amps
Response Time.....	< 5 nanoseconds

Provide a loop surge suppressor for each set of loop terminals in the cabinet. Ensure the device meets the following specifications:

Peak Surge Current (6 times, 8x20µs)	
(Differential Mode).....	400A
(Common Mode).....	1,000A



**U-4405**

**TS-17**

**Cumberland County**

- Occurrences (8x20µs waveform).....500 min @ 200A
- Maximum Clamp Voltage
  - (Differential Mode @400A).....35V
  - (Common Mode @1,000A).....35V
- Response Time.....< 5 nanoseconds
- Maximum Capacitance.....35 pF

Provide a data communications surge suppressor for each communications line entering or leaving the cabinet. Ensure the device meets the following specifications:

- Peak Surge Current (Single pulse, 8x20µs).....10,000A
- Occurrences (8x20µs waveform).....100 min @ 2,000A
- Maximum Clamp Voltage .....Rated for equipment protected
- Response Time.....< 1 nanosecond
- Maximum Capacitance.....1,500 pF
- Maximum Series Resistance.....15Ω

Provide a DC signal surge suppressor for each DC input channel in the cabinet. Ensure the device meets the following specifications:

- Peak Surge Current (Single pulse, 8x20µs).....10,000A
- Occurrences (8x20µs waveform).....100 @ 2,000A
- Maximum Clamp Voltage .....30V
- Response Time.....< 1 nanosecond

Provide a 120 VAC signal surge suppressor for each AC+ interconnect signal input. Ensure the device meets the following specifications:

- Peak Surge Current (Single pulse, 8x20µs).....20,000A
- Maximum Clamp Voltage .....350VAC
- Response Time.....< 200 nanoseconds
- Discharge Voltage .....<200 Volts @ 1,000A
- Insulation Resistance.....≥100 MΩ

## U-4405

## TS-18

## Cumberland County

Provide conductors for surge protection wiring that are of sufficient size (ampacity) to withstand maximum overcurrents which could occur before protective device thresholds are attained and current flow is interrupted.

If additional surge protected power outlets are needed to accommodate fiber transceivers, modems, etc., install a UL listed, industrial, heavy-duty type power outlet strip with a minimum rating of 15 A / 125 VAC, 60 Hz. Provide a strip that has a minimum of 3 grounded outlets. Ensure the power outlet strip plugs into one of the controller unit receptacles located on the rear of the PDA. Ensure power outlet strip is mounted securely; provide strain relief if necessary.

Provide a door switch in the front and a door switch in the rear of the cabinet that will provide the controller unit with a Door Ajar alarm when either the front or the rear door is open. Ensure the door switches apply DC ground to the Input File when either the front door or the rear door is open.

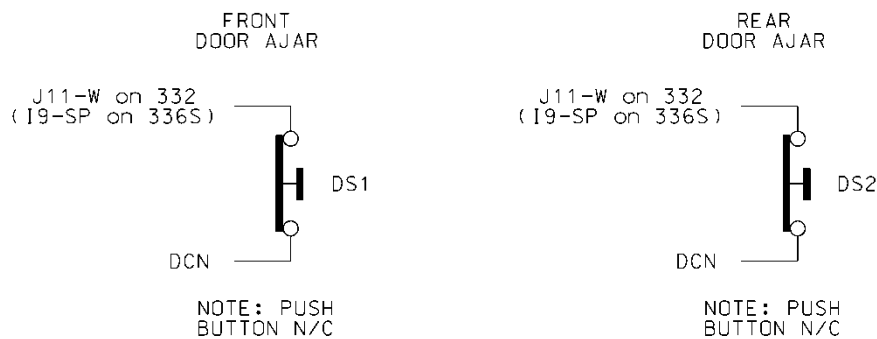

Furnish a fluorescent fixture in the rear across the top of the cabinet and another fluorescent fixture in the front across the top of the cabinet at a minimum. Ensure that the fixtures provide sufficient light to illuminate all terminals, labels, switches, and devices in the cabinet. Conveniently locate the fixtures so as not to interfere with a technician's ability to perform work on any devices or terminals in the cabinet. Provide a protective diffuser to cover exposed bulbs. Install 16-watt T-4 lamps in the fluorescent fixtures. Provide a door switch to provide power to each fixture when the respective door is open. Wire the fluorescent fixtures to the 15-amp ECB (equipment circuit breaker).



U-4405

TS-20

Cumberland County

336S Cabinet														
Port-Bit/C-1 Pin Assignment														
Slot #	1	2	3	4	5	6	7	8	9	10	11	12	13	14
C-1 (Spares)	59	60	61	62	63	64	65	66	75	76	77	78	79	80
Port	3-2	1-1	3-4	1-3	3-1	1-2	3-3	1-4	2-5	5-5	5-6	5-1	5-2	6-7
C-1	56	39	58	41	55	40	57	42	51	71	72	67	68	81
Port	2-1	1-5	2-3	1-7	2-2	1-6	2-4	1-8	2-6	5-7	5-8	5-3	5-4	6-8
C-1	47	43	49	45	48	44	50	46	52	73	74	69	70	82

For model 332 base mounted cabinets, ensure terminals J14-E and J14-K are wired together on the rear of the Input File. Connect TB9-12 (J14 Common) on the Input Panel to T1-2 (AC-) on the rear of the PDA.

Provide detector test switches mounted at the top of the cabinet rack or other convenient location which may be used to place a call on each of eight phases based on the chart below. Provide three positions for each switch: On (place call), Off (normal detector operation), and Momentary On (place momentary call and return to normal detector operation after switch is released). Ensure that the switches are located such that the technician can read the controller display and observe the intersection.

Connect detector test switches for cabinets as follows:

336S Cabinet		332 Cabinet	
Detector Call Switches	Terminals	Detector Call Switches	Terminals
Phase 1	I1-F	Phase 1	I1-W
Phase 2	I2-F	Phase 2	I4-W
Phase 3	I3-F	Phase 3	I5-W
Phase 4	I4-F	Phase 4	I8-W
Phase 5	I5-F	Phase 5	J1-W
Phase 6	I6-F	Phase 6	J4-W
Phase 7	I7-F	Phase 7	J5-W
Phase 8	I8-F	Phase 8	J8-W

Provide the PCB 28/56 connector for the conflict monitor unit (CMU) with 28 independent contacts per side, dual-sided with 0.156-inch contact centers. Provide the PCB 28/56 connector contacts with solder eyelet terminations. Ensure all connections to the PCB 28/56 connector are soldered to the solder eyelet terminations.

## U-4405

## TS-21

## Cumberland County

Ensure that all cabinets have the CMU connector wired according to the 332 cabinet connector pin assignments (include all wires for auxiliary output file connection). Wire pins 13, 16, R, and U of the CMU connector to a separate 4 pin plug, P1, as shown below. Provide a second plug, P2, which will mate with P1 and is wired to the auxiliary output file as shown below. Provide an additional plug, P3, which will mate with P1 and is wired to the pedestrian yellow circuits as shown below. When no auxiliary output file is installed in the cabinet, provide wires for the green and yellow inputs for channels 11, 12, 17, and 18, the red inputs for channels 17 and 18, and the wires for the P2 plug. Terminate the two-foot wires with ring type lugs, insulated, and bundled for optional use.

PIN	P1		P2		P3	
	FUNCTION	CONN TO	FUNCTION	CONN TO	FUNCTION	CONN TO
1	CH-9G	CMU-13	OLA-GRN	A123	2P-YEL	114
2	CH-9Y	CMU-16	OLA-YEL	A122	4P-YEL	105
3	CH-10G	CMU-R	OLB-GRN	A126	6P-YEL	120
4	CH-10Y	CMU-U	OLB-YEL	A125	8P-YEL	111

Do not provide the P20 terminal assembly (red monitor board) or red interface ribbon cable as specified in LA Specification No. 54-053-08.

Provide a P20 connector that mates with and is compatible with the red interface connector mounted on the front of the conflict monitor. Ensure that the P20 connector and the red interface connector on the conflict monitor are center polarized to ensure proper connection. Ensure that removal of the P20 connector will cause the conflict monitor to recognize a latching fault condition and place the cabinet into flashing operation.

Wire the P20 connector to the output file and auxiliary output file using 22 AWG stranded wires. Ensure the length of these wires is a minimum of 42 inches in length. Provide a durable braided sleeve around the wires to organize and protect the wires.

Wire the P20 connector to the traffic signal red displays to provide inputs to the conflict monitor as shown below. Ensure the pedestrian Don't Walk circuits are wired to channels 13 through 16 of the P20 connector. When no auxiliary output file is installed in the cabinet, provide wires for channels 9 through 12 reds. Provide a wire for special function 1. Terminate the unused wires with ring type lugs, insulated, and bundled for optional use.

P20 Connector					
PIN	FUNCTION	CONN TO	PIN	FUNCTION	CONN TO
1	Channel 15 Red	119	2	Channel 16 Red	110
3	Channel 14 Red	104	4	Chassis GND	01-9
5	Channel 13 Red	113	6	N/C	
7	Channel 12 Red	AUX 101	8	Spec Function 1	
9	Channel 10 Red	AUX 124	10	Channel 11 Red	AUX 114

11	Channel 9 Red	AUX 121	12	Channel 8 Red	107
13	Channel 7 Red	122	14	Channel 6 Red	134
15	Channel 5 Red	131	16	Channel 4 Red	101
17	Channel 3 Red	116	18	Channel 2 Red	128
19	Channel 1 Red	125	20	Red Enable	01-14

Ensure the controller unit outputs to the auxiliary output file are pre-wired to the C5 connector. When no auxiliary output file is installed in the cabinet, connect the C5 connector to a storage socket located on the Input Panel or on the rear of the PDA.

Do not wire pin 12 of the load switch sockets.

In addition to the requirements of LA Specification No. 54-053-08, ensure relay K1 on the Power Distribution Assembly (PDA) is a four-pole relay and K2 on the PDA is a two-pole relay.

Provide a two pole, ganged circuit breaker for the flash bus circuit. Ensure the flash bus circuit breaker is an inverse time circuit breaker rated for 10 amps at 120 VAC with a minimum of 10,000 RMS symmetrical amperes short circuit current rating. Do not provide the auxiliary switch feature on the flash bus circuit breaker. Ensure the ganged flash bus circuit breaker is certified by the circuit breaker manufacturer to provide gang tripping operation.

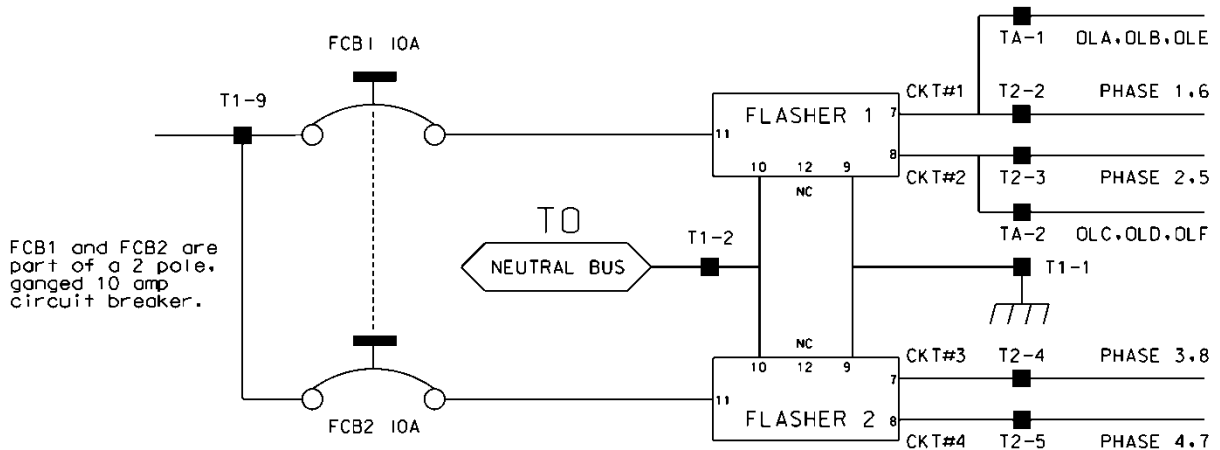

Ensure auxiliary output files are wired as follows:

U-4405

TS-23

Cumberland County

AUXILIARY OUTPUT FILE TERMINAL BLOCK TA ASSIGNMENTS	
POSITION	FUNCTION
1	Flasher Unit #1, Circuit 1/FTR1 (OLA, OLB)/FTR3 (OLE)
2	Flasher Unit #1, Circuit 2/FTR2 (OLC, OLD)/FTR3 (OLF)
3	Flash Transfer Relay Coils
4	AC -
5	Power Circuit 5
6	Power Circuit 5
7	Equipment Ground Bus
8	NC

Provide four spare load resistors mounted in each cabinet. Ensure each load resistor is rated as shown in the table below. Wire one side of each load resistor to AC-. Connect the other side of each resistor to a separate terminal on a four (4) position terminal block. Mount the load resistors and terminal block either inside the back of Output File No. 1 or on the upper area of the Service Panel.

ACCEPTABLE LOAD RESISTOR VALUES	
VALUE (ohms)	WATTAGE
1.5K – 1.9 K	25W (min)
2.0K – 3.0K	10W (min)

Provide Model 200 load switches, Model 204 flashers, Model 242 DC isolators, Model 252 AC isolators, and Model 206L power supply units that conform to CALTRANS' *"Transportation Electrical Equipment Specifications"* dated March 12, 2009 with Erratum 1.

### C. Type 170 E Cabinet Physical Requirements:

Do not mold, cast, or scribe the name "City of Los Angeles" on the outside of the cabinet door as specified in LA Specification No. 54-053-08. Do not provide a Communications Terminal Panel as specified in LA Specification No. 54-053-08. Do not provide terminal block TBB on the Service Panel. Do not provide Cabinet Verification Test Program software or associated test jigs as specified in LA Specification No. 54-053-08.

**U-4405****TS-24****Cumberland County**

Furnish unpainted, natural, aluminum cabinet shells. Ensure that all non-aluminum hardware on the cabinet is stainless steel or a Department approved non-corrosive alternate.

Ensure the lifting eyes, gasket channels, police panel, and all supports welded to the enclosure and doors are fabricated from 0.125-inch minimum thickness aluminum sheet and meet the same standards as the cabinet and doors.

Provide front and rear doors with latching handles that allow padlocking in the closed position. Furnish 0.75-inch minimum diameter stainless steel handles with a minimum 0.5-inch shank. Place the padlocking attachment at 4.0 inches from the handle shank center to clear the lock and key. Provide an additional 4.0 inches minimum gripping length.

Provide Corbin #2 locks on the front and rear doors. Provide one (1) Corbin #2 and one (1) police master key with each cabinet. Ensure main door locks allow removal of keys in the locked position only.

Provide a surge protection panel with 16 loop surge protection devices and designed to allow sufficient free space for wire connection/disconnection and surge protection device replacement. For model 332 cabinets, provide an additional 20 loop surge protection devices. Provide an additional two AC+ interconnect surge devices to protect one slot and eight DC surge protection devices to protect four slots. Provide no protection devices on slot I14.

For pole mounted cabinets, mount surge protection devices for the AC+ interconnect inputs, inductive loop detector inputs, and low voltage DC inputs on a swing down panel assembly fabricated from sturdy aluminum. Attach the swing down panel to the bottom rear cabinet rack assembly using thumb screws. Ensure the swing down panel allows for easy removal of the input file without removing the surge protection panel assembly or its parts. Have the surge protection devices mounted horizontally on the panel and soldered to the feed through terminals of four 14 position terminal blocks with #8 screws mounted on the other side. Ensure the top row of terminals is connected to the upper slots and the bottom row of terminals is connected to the bottom slots. Provide a 15-position copper equipment ground bus attached to the field terminal side (outside) of the swing down panel for termination of loop lead-in shield grounds. Ensure that a Number 4 AWG green wire connects the surge protection panel assembly ground bus to the main cabinet equipment ground.



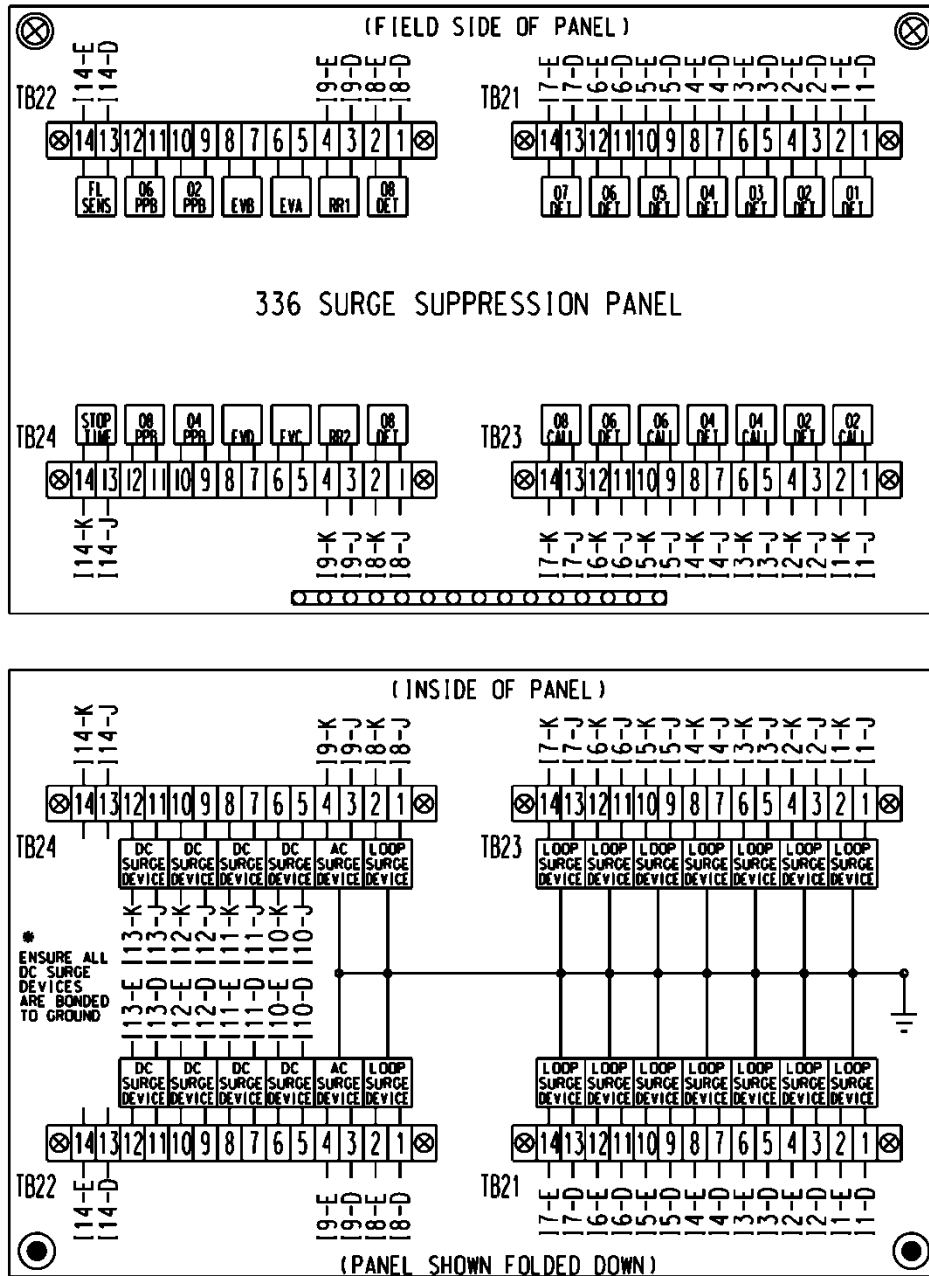

For base mounted cabinets, mount surge protection panels on the left side of the cabinet as viewed from the rear. Attach each panel to the cabinet rack assembly using bolts and make it easily removable. Mount the surge protection devices in vertical rows on each panel and connect the devices to one side of 12 position, double row terminal blocks with #8 screws. For each surge protection panel, terminate all grounds from the surge protection devices on a copper equipment ground bus attached to the surge protection panel. Wire the terminals to the rear of a standard input file using spade lugs for input file protection.

U-4405

TS-26

Cumberland County

Provide permanent labels that indicate the slot and the pins connected to each terminal that may be viewed from the rear cabinet door. Label and orient terminals so that each pair of inputs is next to each other. Indicate on the labeling the input file (I or J), the slot number (1-14) and the terminal pins of the input slots (either D & E for upper or J & K for lower).

Provide a minimum 14 x 16 inch pull out, hinged top shelf located immediately below controller mounting section of the cabinet. Ensure the shelf is designed to fully expose the table surface outside the controller at a height approximately even with the bottom of the controller. Ensure the shelf has a storage bin interior which is a minimum of 1 inch deep and approximately the same dimensions as the shelf. Provide an access to the storage area by lifting the hinged top of the shelf. Fabricate the shelf and slide from aluminum or stainless steel and ensure the assembly can support the 2070L controller plus 15 pounds of additional weight. Ensure shelf has a locking mechanism to secure it in the fully extended position and does not inhibit the removal of the 2070L controller or removal of cards inside the controller when fully extended. Provide a locking mechanism that is easily released when the shelf is to be returned to its non-use position directly under the controller.

#### **D. Model 2018 Enhanced Conflict Monitor:**

Furnish Model 2018 Enhanced Conflict Monitors that provide monitoring of 18 channels. Ensure each channel consists of a green, yellow, and red field signal input. Ensure that the conflict monitor meets or exceeds CALTRANS' Transportation Electrical Equipment Specifications dated March 12, 2009, with Erratum 1 (hereafter referred to as CALTRANS' 2009 TEES) for a model 210 monitor unit and other requirements stated in this specification.

Ensure the conflict monitor is provided with an 18-channel conflict programming card. Pin EE and Pin T of the conflict programming card shall be connected together. Pin 16 of the conflict programming card shall be floating. Ensure that the absence of the conflict programming card will cause the conflict monitor to trigger (enter fault mode), and remain in the triggered state until the programming card is properly inserted, and the conflict monitor is reset.

Provide a conflict monitor that incorporates LED indicators into the front panel to dynamically display the status of the monitor under normal conditions and to provide a comprehensive review of field inputs with monitor status under fault conditions. Ensure that the monitor indicates the channels that were active during a conflict condition and the channels that experienced a failure for all other per channel fault conditions detected. Ensure that these indications and the status of each channel are retained until the Conflict Monitor is reset. Furnish LED indicators for the following:

- AC Power (Green LED indicator)
- VDC Failed (Red LED indicator)
- WDT Error (Red LED indicator)
- Conflict (Red LED indicator)
- Red Fail (Red LED indicator)
- Dual Indication (Red LED indicator)
- Yellow/Clearance Failure (Red LED indicator)
- PCA/PC Ajar (Red LED indicator)
- Monitor Fail/Diagnostic Failure (Red LED indicator)

- 54 Channel Status Indicators (1 Red, 1 Yellow, and 1 Green LED indicator for each of the 18 channels)

Provide a switch to set the Red Fail fault timing. Ensure that when the switch is in the ON position the Red Fail fault timing value is set to 1350 +/- 150 ms (2018 mode). Ensure that when the switch is in the OFF position the Red Fail fault timing value is set to 850 +/- 150 ms (210 mode).

Provide a switch to set the Watchdog fault timing. Ensure that when the switch is in the ON position the Watchdog fault timing value is set to 1.0 +/- 0.1 s (2018 mode). Ensure that when the switch is in the OFF position the Watchdog fault timing value is set to 1.5 +/- 0.1 s (210 mode).

Provide a jumper or switch to set the AC line brown-out levels. Ensure that when the jumper is present, or the switch is in the ON position the AC line dropout voltage threshold is 98 +/- 2 Vrms, the AC line restore voltage threshold is 103 +/- 2 Vrms, and the AC line brown-out timing value is set to 400 +/- 50ms (2018 mode). Ensure that when the jumper is not present, or the switch is in the OFF position the AC line dropout voltage threshold is 92 +/- 2 Vrms, the AC line restore voltage threshold is 98 +/- 2 Vrms, and the AC line brown-out timing value is set to 80 +/- 17 ms (210 mode).

Provide a jumper or switch that will enable and disable the Watchdog Latch function. Ensure that when the jumper is not present, or the switch is in the OFF position the Watchdog Latch function is disabled. In this mode of operation, a Watchdog fault will be reset following a power loss, brownout, or power interruption. Ensure that when the jumper is present, or the switch is in the ON position the Watchdog Latch function is enabled. In this mode of operation, a Watchdog fault will be retained until a Reset command is issued.

Provide a jumper that will reverse the active polarity for pin #EE (output relay common). Ensure that when the jumper is not present pin #EE (output relay common) will be considered 'Active' at a voltage greater than 70 Vrms and 'Not Active' at a voltage less than 50 Vrms (Caltrans mode). Ensure that when the jumper is present pin #EE (output relay common) will be considered 'Active' at a voltage less than 50 Vrms and 'Not Active' at a voltage greater than 70 Vrms (Failsafe mode).

In addition to the connectors required by CALTRANS' 2009 TEES, provide the conflict monitor with a red interface connector mounted on the front of the monitor. Ensure the connector is a 20 pin, right angle, center polarized, male connector with latching clip locks and polarizing keys. Ensure the right-angle solder tails are designed for a 0.062" thick printed circuit board. Keying of the connector shall be between pins 3 and 5, and between 17 and 19. Ensure the connector has two rows of pins with the odd numbered pins on one row and the even pins on the other row. Ensure the connector pin row spacing is 0.10" and pitch is 0.10". Ensure the mating length of the connector pins is 0.24". Ensure the pins are finished with gold plating 30μ" thick.

U-4405

TS-28

Cumberland County

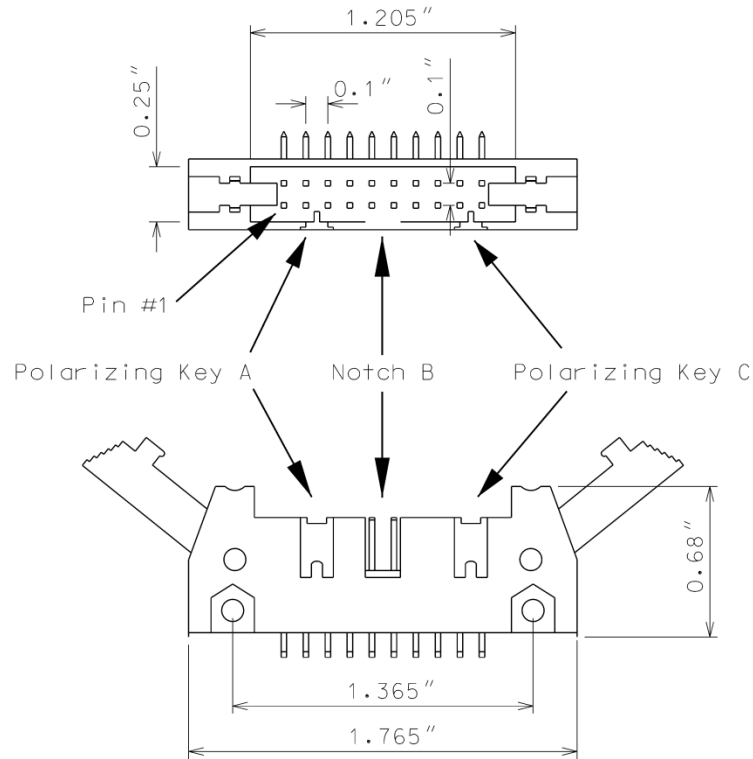

Ensure the red interface connector pins on the monitor have the following functions:

Pin #	Function	Pin #	Function
1	Channel 15 Red	2	Channel 16 Red
3	Channel 14 Red	4	Chassis Ground
5	Channel 13 Red	6	Special Function 2
7	Channel 12 Red	8	Special Function 1
9	Channel 10 Red	10	Channel 11 Red
11	Channel 9 Red	12	Channel 8 Red
13	Channel 7 Red	14	Channel 6 Red
15	Channel 5 Red	16	Channel 4 Red
17	Channel 3 Red	18	Channel 2 Red
19	Channel 1 Red	20	Red Enable

Ensure that removal of the P20 cable connector will cause the conflict monitor to recognize a latching fault condition and place the cabinet into flashing operation.

Provide Special Function 1 and Special Function 2 inputs to the unit which shall disable only Red Fail Monitoring when either input is sensed active. A Special Function input shall be sensed active when the input voltage exceeds 70 Vrms with a minimum duration of 550 ms. A Special Function input shall be sensed not active when the input voltage is less than 50 Vrms or the duration is less than 250 ms. A Special Function input is undefined by these specifications and may or may not be sensed active when the input voltage is between 50 Vrms and 70 Vrms or the duration is between 250 ms and 550 ms.

Ensure the conflict monitor recognizes field signal inputs for each channel that meet the following requirements:

- consider a Red input greater than 70 Vrms and with a duration of at least 500 ms as an “on” condition;
- consider a Red input less than 50 Vrms or with a duration of less than 200 ms as an “off” condition (no valid signal);
- consider a Red input between 50 Vrms and 70 Vrms or with a duration between 200 ms and 500 ms to be undefined by these specifications;
- consider a Green or Yellow input greater than 25 Vrms and with a duration of at least 500 ms as an “on” condition;
- consider a Green or Yellow input less than 15 Vrms or with a duration of less than 200 ms as an “off” condition; and
- consider a Green or Yellow input between 15 Vrms and 25 Vrms or with a duration between 200 ms and 500 ms to be undefined by these specifications.

Provide a conflict monitor that recognizes the faults specified by CALTRANS’ 2009 TEES and the following additional faults. Ensure the conflict monitor will trigger upon detection of a fault and will remain in the triggered (in fault mode) state until the unit is reset at the front panel or through the external remote reset input for the following failures:

1. **Red Monitoring or Absence of Any Indication (Red Failure):** A condition in which no “on” voltage signal is detected on any of the green, yellow, or red inputs to a given monitor channel. If a signal is not detected on at least one input (R, Y, or G) of a conflict monitor channel for a period greater than 1000 ms when used with a 170 controller and 1500 ms when used with a 2070 controller, ensure monitor will trigger and put the intersection into flash. If the absence of any indication condition lasts less than 700 ms when used with a 170 controller and 1200 ms when used with a 2070 controller, ensure conflict monitor will not trigger. Red fail monitoring shall be enabled on a per channel basis by the use of switches located on the conflict monitor. Have red monitoring occur when all of the following input conditions are in effect:
  - a) Red Enable input to monitor is active (Red Enable voltages are “on” at greater than 70 Vrms, off at less than 50 Vrms, undefined between 50 and 70 Vrms), and
  - b) Neither Special Function 1 nor Special Function 2 inputs are active.
  - c) Pin #EE (output relay common) is not active

2. **Short/Missing Yellow Indication Fault (Clearance Error):** Yellow indication following a green is missing or shorter than 2.7 seconds (with  $\pm 0.1$ -second accuracy). If a channel fails to detect an “on” signal at the Yellow input for a minimum of 2.7 seconds ( $\pm 0.1$  second) following the detection of an “on” signal at a Green input for that channel, ensure that the monitor triggers and generates a clearance/short yellow error fault indication. Short/missing yellow (clearance) monitoring shall be enabled on a per channel basis by the use of switches located on the conflict monitor. This fault shall not occur when the channel is programmed for Yellow Inhibit, when the Red Enable signal is inactive or pin #EE (output relay common) is active.
3. **Dual Indications on the Same Channel:** In this condition, more than one indication (R,Y,G) is detected as “on” at the same time on the same channel. If dual indications are detected for a period greater than 500 ms, ensure that the conflict monitor triggers and displays the proper failure indication (Dual Ind fault). If this condition is detected for less than 200 ms, ensure that the monitor does not trigger. G-Y-R dual indication monitoring shall be enabled on a per channel basis by the use of switches located on the conflict monitor. G-Y dual indication monitoring shall be enabled for all channels by use of a switch located on the conflict monitor. This fault shall not occur when the Red Enable signal is inactive or pin #EE (output relay common) is active.
4. **Configuration Settings Change:** The configuration settings are comprised of (as a minimum) the permissive diode matrix, dual indication switches, yellow disable jumpers, any option switches, any option jumpers, and the Watchdog Enable switch. Ensure the conflict monitor compares the current configuration settings with the previous stored configuration settings on power-up, on reset, and periodically during operation. If any of the configuration settings are changed, ensure that the conflict monitor triggers and causes the program card indicator to flash. Ensure that configuration change faults are only reset by depressing and holding the front panel reset button for a minimum of three seconds. Ensure the external remote reset input does not reset configuration change faults.

Ensure the conflict monitor will trigger and the AC Power indicator will flash at a rate of 2 Hz  $\pm$  20% with a 50% duty cycle when the AC Line voltage falls below the “drop-out” level. Ensure the conflict monitor will resume normal operation when the AC Line voltage returns above the “restore” level. Ensure the AC Power indicator will remain illuminated when the AC voltage returns above the “restore” level. Should an AC Line power interruption occur while the monitor is in the fault mode, then upon restoration of AC Line power, the monitor will remain in the fault mode and the correct fault and channel indicators will be displayed.

Provide a flash interval of at least 6 seconds and at most 10 seconds in duration following a power-up, an AC Line interruption, or a brownout restore. Ensure the conflict monitor will suspend all fault monitoring functions, close the Output relay contacts, and flash the AC indicator at a rate of 4 Hz  $\pm$  20% with a 50% duty cycle during this interval. Ensure the termination of the flash interval after at least 6 seconds if the Watchdog input has made 5 transitions between the True and False state and the AC Line voltage is greater than the “restore” level. If the watchdog input has not made 5 transitions between the True and False state within  $10 \pm 0.5$  seconds, the monitor shall enter a WDT error fault condition.

**U-4405****TS-31****Cumberland County**

Ensure the conflict monitor will monitor an intersection with a minimum of four approaches using the four-section Flashing Yellow Arrow (FYA) vehicle traffic signal as outlined by the NCHRP 3-54 research project for protected-permissive left turn signal displays. Ensure the conflict monitor will operate in the FYA mode and FYAc (Compact) mode as specified below to monitor each channel pair for the following fault conditions: Conflict, Flash Rate Detection, Red Fail, Dual Indication, and Clearance. Provide a switch to select between the FYA mode and FYAc mode. Provide a switch to select each FYA phase movement for monitoring.

**FYA mode**

FYA Signal Head	Phase 1	Phase 3	Phase 5	Phase 7
Red Arrow	Channel 9 Red	Channel 10 Red	Channel 11 Red	Channel 12 Red
Yellow Arrow	Channel 9 Yellow	Channel 10 Yellow	Channel 11 Yellow	Channel 12 Yellow
Flashing Yellow Arrow	Channel 9 Green	Channel 10 Green	Channel 11 Green	Channel 12 Green
Green Arrow	Channel 1 Green	Channel 3 Green	Channel 5 Green	Channel 7 Green

**FYAc mode**

FYA Signal Head	Phase 1	Phase 3	Phase 5	Phase 7
Red Arrow	Channel 1 Red	Channel 3 Red	Channel 5 Red	Channel 7 Red
Yellow Arrow	Channel 1 Yellow	Channel 3 Yellow	Channel 5 Yellow	Channel 7 Yellow
Flashing Yellow Arrow	Channel 1 Green	Channel 3 Green	Channel 5 Green	Channel 7 Green
Green Arrow	Channel 9 Green	Channel 9 Yellow	Channel 10 Green	Channel 10 Yellow

If a FYA channel pair is enabled for FYA operation, the conflict monitor will monitor the FYA logical channel pair for the additional following conditions:

1. **Conflict:** Channel conflicts are detected based on the permissive programming jumpers on the program card. This operation remains unchanged from normal operation except for the solid Yellow arrow (FYA clearance) signal.
2. **Yellow Change Interval Conflict:** During the Yellow change interval of the Permissive Turn channel (flashing Yellow arrow) the conflict monitor shall verify that no conflicting channels to the solid Yellow arrow channel (clearance) are active. These conflicting channels shall be determined by the program card compatibility programming of the Permissive Turn channel (flashing Yellow arrow). During the Yellow change interval of the Protected Turn channel (solid Green arrow) the conflict monitor shall verify that no conflicting channels to the solid Yellow arrow channel (clearance) are active as determined by the program card compatibility programming of the Protected Turn channel (solid Green arrow).
3. **Flash Rate Detection:** The conflict monitor unit shall monitor for the absence of a valid flash rate for the Permissive turn channel (flashing Yellow arrow). If the Permissive turn channel (flashing Yellow arrow) is active for a period greater than 1600 milliseconds, ensure the conflict monitor triggers and puts the intersection into flash. If the Permissive turn channel (flashing Yellow arrow) is active for a period less than 1400 milliseconds, ensure the conflict monitor does not trigger. Ensure the conflict monitor will remain in the triggered (in fault mode) state until the unit is reset at the front panel or through the external remote reset input. Provide a jumper or switch that will enable and disable the Flash Rate Detection function. Ensure that when the jumper is not present, or the switch is in the OFF position the Flash Rate Detection function is enabled. Ensure that when the jumper is present, or the switch is in the ON position the Flash Rate Detection function is disabled.
4. **Red Monitoring or Absence of Any Indication (Red Failure):** The conflict monitor unit shall detect a red failure if there is an absence of voltage on all four of the inputs of a FYA channel pair (RA, YA, FYA, GA).
5. **Dual Indications on the Same Channel:** The conflict monitor unit shall detect a dual indication if two or more inputs of a FYA channel pair (RA, YA, FYA, GA) are "on" at the same time.
6. **Short/Missing Yellow Indication Fault (Clearance Error):** The conflict monitor unit shall monitor the solid Yellow arrow for a clearance fault when terminating both the Protected Turn channel (solid Green arrow) interval and the Permissive Turn channel (flashing Yellow arrow) interval.

Ensure that the conflict monitor will log at least nine of the most recent events detected by the monitor in non-volatile EEPROM memory (or equivalent). For each event, record at a minimum the time, date, type of event, status of each field signal indication with RMS voltage, and specific channels involved with the event. Ensure the conflict monitor will log the following events: monitor reset, configuration, previous fault, and AC line. Furnish the signal sequence log that shows all channel states (Greens, Yellows, and Reds) and the Red Enable State for a minimum of 2 seconds prior to the current fault trigger point. Ensure the display resolution of the inputs for the signal sequence log is not greater than 50 ms.

For conflict monitors used within an Ethernet communications system, provide a conflict monitor with an Ethernet 10/100 Mbps, RJ-45 port for data communication access to the monitor by



**U-4405****TS-33****Cumberland County**

a local notebook computer and remotely via a workstation or notebook computer device connected to the signal system local area network. The Ethernet port shall be electrically isolated from the conflict monitor's electronics and shall provide a minimum of 1500 Vrms isolation. Integrate monitor with Ethernet network in cabinet. Provide software to retrieve the time and date from a network server in order to synchronize the on-board times between the conflict monitor and the controller. Furnish and install the following Windows based, graphic user interface software on workstations and notebook computers where the signal system client software is installed: 1) software to view and retrieve all event log information, 2) software that will search and display a list of conflict monitor IP addresses and IDs on the network, and 3) software to change the conflict monitor's network parameters such as IP address and subnet mask.

For non-Ethernet connected monitors, provide a RS-232C/D compliant port (DB-9 female connector) on the front panel of the conflict monitor in order to provide communications from the conflict monitor to the 170/2070 controller or to a Department-furnished laptop computer. Electrically isolate the port interface electronics from all monitor electronics, excluding Chassis Ground. Ensure that the controller can receive all event log information through a controller Asynchronous Communications Interface Adapter (Type 170E) or Async Serial Comm Module (2070). Furnish and connect a serial cable from the conflict monitor's DB-9 connector to Comm Port 1 of the 2070 controller. Ensure conflict monitor communicates with the controller. Provide a Windows based graphic user interface software to communicate directly through the same monitor RS-232C/D compliant port to retrieve and view all event log information to a Department-furnished laptop computer. The RS-232C/D compliant port on the monitor shall allow the monitor to function as a DCE device with pin connections as follows:

<b>Conflict Monitor RS-232C/D (DB-9 Female) Pinout</b>		
<b>Pin Number</b>	<b>Function</b>	<b>I/O</b>
1	DCD	O
2	TX Data	O
3	RX Data	I
4	DTR	I
5	Ground	-
6	DSR	O
7	CTS	I
8	RTS	O
9	NC	-

U-4405

TS-34

Cumberland County

---

**MONITOR BOARD EDGE CONNECTOR**

---

<b>Pin #</b>	<b>Function (Back Side)</b>	<b>Pin #</b>	<b>Function (Component Side)</b>
1	Channel 2 Green	A	Channel 2 Yellow
2	Channel 13 Green	B	Channel 6 Green
3	Channel 6 Yellow	C	Channel 15 Green
4	Channel 4 Green	D	Channel 4 Yellow
5	Channel 14 Green	E	Channel 8 Green
6	Channel 8 Yellow	F	Channel 16 Green
7	Channel 5 Green	H	Channel 5 Yellow
8	Channel 13 Yellow	J	Channel 1 Green
9	Channel 1 Yellow	K	Channel 15 Yellow
10	Channel 7 Green	L	Channel 7 Yellow
11	Channel 14 Yellow	M	Channel 3 Green
12	Channel 3 Yellow	N	Channel 16 Yellow
13	Channel 9 Green	P	Channel 17 Yellow
14	Channel 17 Green	R	Channel 10 Green
15	Channel 11 Yellow	S	Channel 11 Green
16	Channel 9 Yellow	T	Channel 18 Yellow
17	Channel 18 Green	U	Channel 10 Yellow
--		--	
18	Channel 12 Yellow	V	Channel 12 Green
19	Channel 17 Red	W	Channel 18 Red
20	Chassis Ground	X	Not Assigned
21	AC-	Y	DC Common
22	Watchdog Timer	Z	External Test Reset
23	+24VDC	AA	+24VDC
24	Tied to Pin 25	BB	Stop Time (Output)
25	Tied to Pin 24	CC	Not Assigned
26	Not Assigned	DD	Not Assigned
27	Relay Output, Side #3, N.O.	EE	Relay Output, Side #2, Common
28	Relay Output, Side #1, N.C.	FF	AC+

-- Slotted for keying between Pins 17/U and 18/V

U-4405

TS-35

Cumberland County

---

**CONFLICT PROGRAM CARD PIN ASSIGNMENTS**

---

<b>Pin #</b>	<b>Function (Back Side)</b>	<b>Pin #</b>	<b>Function (Component Side)</b>
1	Channel 2 Green	A	Channel 1 Green
2	Channel 3 Green	B	Channel 2 Green
3	Channel 4 Green	C	Channel 3 Green
4	Channel 5 Green	D	Channel 4 Green
5	Channel 6 Green	E	Channel 5 Green
6	Channel 7 Green	F	Channel 6 Green
7	Channel 8 Green	H	Channel 7 Green
8	Channel 9 Green	J	Channel 8 Green
9	Channel 10 Green	K	Channel 9 Green
10	Channel 11 Green	L	Channel 10 Green
11	Channel 12 Green	M	Channel 11 Green
12	Channel 13 Green	N	Channel 12 Green
13	Channel 14 Green	P	Channel 13 Green
14	Channel 15 Green	R	Channel 14 Green
15	Channel 16 Green	S	Channel 15 Green
16	N/C	T	PC AJAR
17	Channel 1 Yellow	U	Channel 9 Yellow
18	Channel 2 Yellow	V	Channel 10 Yellow
19	Channel 3 Yellow	W	Channel 11 Yellow
20	Channel 4 Yellow	X	Channel 12 Yellow
21	Channel 5 Yellow	Y	Channel 13 Yellow
22	Channel 6 Yellow	Z	Channel 14 Yellow
23	Channel 7 Yellow	AA	Channel 15 Yellow
24	Channel 8 Yellow	BB	Channel 16 Yellow
--		--	
25	Channel 17 Green	CC	Channel 17 Yellow
26	Channel 18 Green	DD	Channel 18 Yellow
27	Channel 16 Green	EE	PC AJAR (Program Card)
28	Yellow Inhibit Common	FF	Channel 17 Green

-- Slotted for keying between Pins 24/BB and 25/CC



**U-4405****TS-37****Cumberland County**

characteristics as shown in the wiring detail in Figure 1. Provide 4 terminal screws with saddle clamps.

Provide fuses F1 and F2 as a UL Listed ¼" x 1-1/4" glass tube rated at 250 volts with a 10kA interrupting rating. Ensure F1 non-delay (fast-acting) and F2 slow-blow (time-delay) fuses have a maximum opening times of 60 minutes and 120 seconds for currents of 135 and 200 percent of the ampere rating, respectively. Ensure F2 slow-blow (time-delay) fuses have a minimum opening times of 12 seconds at 200 percent of the ampere rating. Provide fuse holders that are UL Recognized panel-mounted holders rated 250V, 15 ampere minimum with bayonet-type knobs which accept ¼" x 1-1/4" glass tube fuses.

Provide terminal blocks that are rated for 300V and are made of electrical grade thermoplastic or thermosetting plastic. Ensure each terminal block is of closed back design and has recessed-screw terminals with molded barriers between terminals. Ensure each terminal block is labeled with a block designation. Ensure each terminal is labeled with the function and a number.

Provide 3/4-inch diameter radial lead UL-recognized metal oxide varistors (MOVs) that have electrical performance as outlined below.

<b>PROPERTIES OF MOV SURGE PROTECTOR</b>	
Maximum Continuous Applied Voltage at 185° F	150 VAC (RMS) 200 VDC
Maximum Peak 8x20µs Current at 185° F	6500 A
Maximum Energy Rating at 185° F	80 J
Voltage Range 1 mA DC Test at 77° F	212-268 V
Max. Clamping Voltage 8x20µs, 100A at 77° F	395 V
Typical Capacitance (1 MHz) at 77° F	1600 pF

Provide resistor R1 as a 2K ohm, 12 watt, wirewound resistor with tinned terminals and attaching leads. Ensure the resistor is spaced apart from surrounding wires.

Provide a LED or incandescent lamp that has a voltage rating of 120 VAC with a minimum life rating at 50,000 hours.

Wire the preemption and sign control box as shown in Figure 1.

**RAILROAD PREEMPTION WIRING DETAIL**

(wire as shown below)

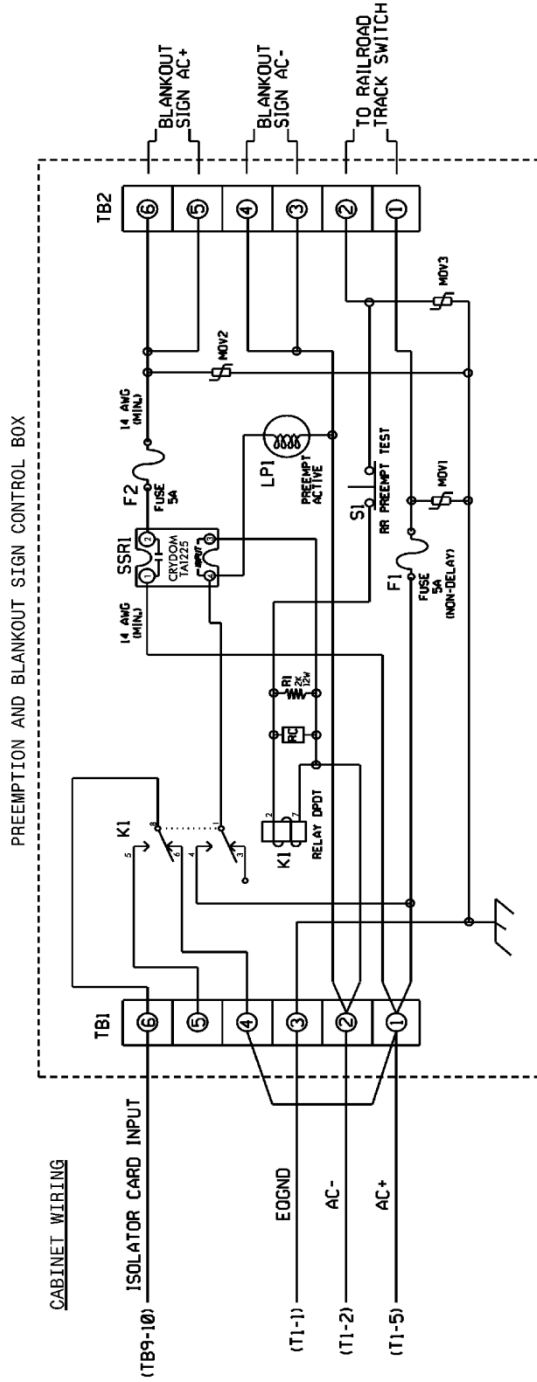

**NOTES**

1. RELAY K1 IS SHOWN IN THE ENERGIZED (PREEMPT NOI ACTIVE) NORMAL OPERATION STATE.
2. AC ISOLATOR CARD SHALL ACTIVATE PREEMPTION UPON REMOVAL OF AC+ FROM INPUT (AS SHOWN ABOVE). THIS IS ACCOMPLISHED BY SETTING TYPE 252 AC ISOLATOR CARD TO INVERTED OPERATION.

**FRONT VIEW**

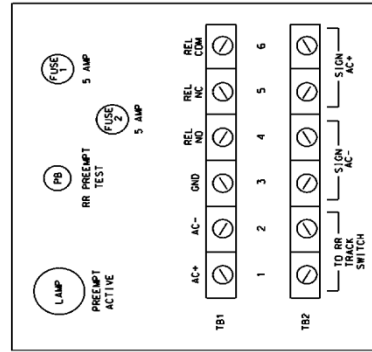

Figure 1

U-4405

TS-39

Cumberland County

### 3.3. MATERIALS – TYPE 2070LX CONTROLLERS

Furnish model 2070LX controller units that conform to CALTRANS *Transportation Electrical Equipment Specifications* (TEES) (dated March 12, 2009, plus Errata 1 dated January 21, 2010 and Errata 2 dated December 5, 2014) except as required herein.

The Department will provide software at the beginning of the burning-in period. Contractor shall give 5 working days notice before needing software. Program software provided by the Department.

Provide model 2070LX controllers with Linux kernel 2.6.18 or higher and device drivers, composed of the unit chassis and at a minimum the following modules and assemblies:

- MODEL 2070-1C, CPU Module, Single Board, with 8Mb Datakey (blue in color)
- MODEL 2070-2E+, Field I/O Module (FI/O)
  - Note: Configure the Field I/O Module to disable both the External WDT Shunt/Toggle Switch and SP3 (SP3 active indicator is “off”)
- MODEL 2070-3B, Front Panel Module (FP), Display B (8x40)
- MODEL 2070-4A, Power Supply Module, 10 AMP

Provide a Board Support Package (BSP) to the state and to any specified applications software manufacturer when requested by the state to facilitate the porting of application software.

Improvements to the NCDOT project U-4405 require the use of proprietary equipment to remain compatible with the Fayetteville Computerized Signal System. The City of Fayetteville currently operates Econolite 1C CPU modules in all controllers. In accordance with 23 CFR 634.411(a)(2), we are certifying that the following proprietary items are required for “synchronization” with the City’s signal system:

7 - Econolite 1C CPU modules

## 4. VIDEO IMAGING LOOP EMULATOR DETECTOR SYSTEMS

### 4.1. DESCRIPTION

Design, furnish, provide training, and install video imaging loop emulator detection systems with all necessary hardware in accordance with the plans and specifications.

Unless otherwise specified in the contract, all loop emulator detection equipment will remain the property of the contractor.

### 4.2. MATERIALS

#### A. General:

Material and equipment furnished under this section must be pre-approved on the Department’s QPL by the date of installation except miscellaneous hardware such as cables and mounting hardware do not need to be pre-approved.

Used equipment will be acceptable provided the following conditions have been met:

- Equipment is listed on the current QPL.
- Equipment is in good working condition.
- Equipment is to remain the property of the contractor.

**U-4405****TS-40****Cumberland County**

Ensure that software is licensed for use by the Department and by any other agency responsible for maintaining or operating the loop emulation system. Provide the Department with a license to duplicate and distribute the software as necessary for design and maintenance support.

Design and furnish video imaging loop emulator detection systems that detect vehicles at signalized intersections by processing video images and providing detection outputs to the signal controller in real time (within 112 milliseconds of vehicle arrival).

Furnish all required camera sensor units, loop emulator processor units, hardware and software packages, cabling, poles, mast arms, harnesses, camera mounting assemblies, surge protection panels, grounding systems, messenger cable and all necessary hardware. Furnish systems that allow the display of detection zones superimposed on an image of the roadway on a Department-furnished monitor or laptop computer screen. Ensure detection zones can be defined and data entered using a simple keyboard or mouse and monitor, or using a laptop PC with software.

Provide design drawings showing design details and camera sensor unit locations for review and acceptance before installation. Provide mounting height and location requirements for camera sensor units on the design based on site survey. Design video imaging loop emulator detection systems with all necessary hardware. Indicate all necessary poles, spans, mast arms, luminaire arms, cables, camera mounting assemblies and hardware to achieve the required detection zones where Department owned poles are not adequate to locate the camera sensor units. Do not design for the installation of poles in medians.

Obtain the Engineer's approval before furnishing video imaging loop emulator detection systems. The contractor is responsible for the final design of video imaging loop emulator detection systems. Review and acceptance of the designs by the Department does not relieve the contractor from the responsibility to provide fully functional systems and to ensure that the required detection zones can be provided.

Provide the ability to program each detection call (input to the controller) with the following functions:

- Full Time Delay – Delay timer is active continuously,
- Normal Delay – Delay timer is inhibited when assigned phase is green (except when used with TS 2 and 170/2070L controllers),
- Extend – Call is extended for this amount of time after vehicle leaves detection area,
- Delay Call/Extend Call – This feature uses a combination of full time delay and extend time on the same detection call. Ensure operation is as follows: Vehicle calls are received after the delay timer times out. When a call is detected, it is held until the detection area is empty and the programmed extend time expires. If another vehicle enters the detection area before the extend timer times out, the call is held and the extend time is reset. When the extend timer times out, the delay timer has to expire before another vehicle call can be received.

Provide the ability to program each detection zone as one of the following functions:

- Presence detector,
- Directional presence detector,
- Pulse detector,



U-4405

TS-41

Cumberland County

- Directional pulse detector.

Ensure previously defined detector zones and configurations can be edited.

Provide each individual system with all the necessary equipment to focus and zoom the camera lenses without the need to enter the camera enclosure.

Provide systems that allow for the placement of at least 8 detection zones within the combined field of view of a single camera sensor unit. Provide a minimum of 8 detection outputs per camera.

Provide detection zones that can be overlapped. Ensure systems reliably detect vehicles when the horizontal distance from the camera sensor unit to the detection zone area is less than ten times the mounting height of the sensor. Ensure systems detect vehicles in multiple travel lanes.

Ensure systems can detect vehicle presence within a 98 to 102 percent accuracy (up to 2 percent of the vehicles missed and up to 2 percent of false detection) for clear, dry, daylight conditions, a 96 to 105 percent accuracy (up to 4 percent of the vehicles missed and up to 5 percent false detection) for dawn and dusk conditions, and a 96 percent accuracy (up to 4 percent of the vehicles missed) for night and adverse conditions (fog, snow, rain, etc.) using standard sensor optics and in the absence of occlusion.

Repair and replace all failed components within 72 hours.

The Department may conduct field-testing to ensure the accuracy of completed video imaging loop emulator detection systems.

### **B. Loop Emulator System:**

Furnish loop emulator systems that receive and simultaneously process information from camera sensor units, and provides detector outputs to signal controllers.

Ensure systems provide the following:

- Operate in a typical roadside environment and meet the environmental specifications and are fully compatible with NEMA TS 1, NEMA TS 2, or Type 170/2070L controllers and cabinets,
- provide a “fail-safe” mode whereby failure of one or more of the camera sensor units or power failure of the loop emulator system will cause constant calls to be placed on the affected vehicle detection outputs to the signal controller,
- provide compensation for minor camera movement of up to 2 percent of the field of view at 400 feet without falsely detecting vehicles,
- process the video at a minimum rate of 30 times per second,
- provide separate wired connectors inside the controller cabinet for video recording each camera,
- provide remote video monitoring with a minimum refresh rate at 1 frame per second over a standard dial-up telephone line,
- provide remote video detection monitoring.
- Furnish camera sensor units that comply with the following:
- have an output signal conforming to EIA RS-170 standard,

- have a nominal output impedance of 75 ohms,
- be immune to bright light sources, or have built in circuitry or protective devices to prevent damage to the sensor when pointed directly at strong light sources,
- be housed in a light colored environmental enclosure that is water proof and dust tight, and that conforms to NEMA-4 specifications or better,
- simultaneously monitor at least five travel lanes when placed at the proper mounting location with a zoom lens,
- have a sunshield attached to the environmental enclosure to minimize solar heating,
- meet FCC class B requirements for electromagnetic interference emissions,
- have a heater attached to the viewing window of the environmental enclosure to prevent ice and condensation in cold weather.

Where coaxial video cables and other cables are required between the camera sensor and other components located in the controller cabinet, furnish surge protection in the controller cabinet.

If furnishing coaxial communications cable comply with the following, as recommended by the approved loop emulator manufacturer:

- Number 20 AWG, solid bare copper conductor terminated with crimped-on BNC connectors (do not use BNC adapters) from the camera sensor to the signal controller cabinet.
- Number 22 AWG, stranded bare copper conductor terminated with crimped-on BNC connectors (do not use BNC adapters) from the camera sensor unit to the junction box, and within the signal controller cabinet.

Furnish power cable appropriately sized to meet the power requirements of the sensors. At a minimum, provide three conductor 120 VAC field power cable.

As determined during the site survey, furnish sensor junction boxes with nominal 6 x 10 x 6 inches dimensions at each sensor location. Provide terminal blocks and tie points for coaxial cable.

### **C. Video Imaging Loop Emulator System Support:**

Furnish video imaging loop emulator systems with either a simple keyboard or a mouse with monitor and appropriate software, or with system software for use on department-owned laptop PCs. Ensure the system is Windows 2000 and Windows XP compatible.

Provide Windows 2000 and Windows XP compatible personal computer software, if needed, to provide remote video and video detection monitoring.

Ensure systems allow the user to edit previously defined detector configurations. When a vehicle is within a detection zone, provide for a change in color or intensity of the detection zone perimeter or other appropriate display changes on the Department-furnished monitor or laptop computer screen.

Provide cabling and interconnection hardware with 6-foot minimum length interconnection cable to interface with the system.

Provide all associated equipment manuals and documentation.

### 4.3. CONSTRUCTION METHODS

Arrange and conduct site surveys with the system manufacturer's representative and Department personnel to determine proper camera sensor unit selection and placement. Provide the Department at least 3 working days notice before conducting site surveys. Upon completion of the site surveys the Department will provide revised plans reflecting the findings of the site survey.

Before beginning work at locations requiring video imaging loop emulator detection systems, furnish system software. Upon activation of detection zones, provide detector configuration files. Ensure that up-to-date detection configuration files are furnished for various detection zone configurations that may be required for construction phasing.

Place into operation loop emulator detection systems. Configure loop emulator detection systems to achieve required detection in designated zones. Have a certified manufacturer's representative on site to supervise and assist with installation, set up, and testing of the system.

Install the necessary processing and communications equipment in the signal controller cabinet. Make all necessary modifications to install equipment, cabling harnesses, and camera sensor interface panels with surge suppression.

Perform modifications to camera sensor unit gain, sensitivity, and iris limits necessary to complete the installation.

Do not install camera sensor units on signal poles unless approved by the Engineer.

Install the necessary cables from each sensor to the signal controller cabinet along signal cabling routes. Install surge protection and terminate all cable conductors.

Relocate camera sensor units and reconfigure detection zones as necessary according to the plans for construction phases.

Provide at least 8 hours of training on the set up, operation, troubleshooting, and maintenance of the loop emulator detection system to a maximum of ten Department personnel. Arrange for training to be conducted by the manufacturer's representative at an approved site within the Division responsible for administration of the project. Thirty days before conducting training submit a detailed course curriculum, draft manuals and materials, and resumes. Obtain approval of the submittal before conducting the training. At least one week before beginning training, provide three sets of complete documentation necessary to maintain and operate the system. Do not perform training until installation of loop emulator detection systems is complete.

### 4.4. MEASUREMENT AND PAYMENT

Actual number of site surveys, arranged, conducted, and accepted.

Actual number of luminaire arms for video systems furnished, installed, and accepted.

Actual number of cameras without internal loop emulator processing units furnished, installed, and accepted.

Actual number of external loop emulator processing units furnished, installed, and accepted.

Actual number of camera sensor units relocated with detection zones reconfigured installed, and accepted.

No measurement will be made of video imaging loop emulator system support or training, power, and video cables, and trenching as these items will be considered incidental to furnishing and installing video imaging loop emulator detection systems.

Payment will be made under:

Site Survey.....	Each
Luminaire Arm for Video System.....	Each
Camera without Internal Loop Emulator Processing Unit.....	Each
External Loop Emulator Processing Unit.....	Each
Relocate Camera Sensor Unit.....	Each

**5. TRAFFIC SIGNAL SUPPORTS**

**5.1. METAL TRAFFIC SIGNAL SUPPORTS – ALL POLES**

**A. General:**

Furnish and install metal strain poles, grounding systems, and all necessary hardware. The work covered by this special provision includes requirements for the design, fabrication, and installation of both standard and custom/site specifically designed metal traffic signal supports and associated foundations.

Provide metal traffic signal support systems that contain no guy assemblies, struts, or stay braces. Provide designs of completed assemblies with hardware that equals or exceeds AASHTO *Standard Specifications for Structural Supports for Highway Signs, Luminaires and Traffic Signals* 6<sup>th</sup> Edition, 2013 (hereafter called 6<sup>th</sup> Edition AASHTO), including the latest interim specifications. Provide assemblies with a round or near-round (18 sides or more) cross-section, or a multi sided cross section with no less than six sides. The sides may be straight, convex, or concave.

Pole heights shown on signal plans are estimated from available data for bid purposes. Prior to furnishing metal signal poles, use field measurements and adjusted cross-sections to determine whether pole heights are sufficient to obtain required clearances. If pole heights are not sufficient, the Contractor should immediately notify the Engineer of the required revised pole heights.

Ensure that metal signal poles permit cables to be installed inside poles and any required mast arms. For holes in the poles and arms used to accommodate cables, provide full-circumference grommets. Arm flange plate wire access holes should be deburred, non grommets, and oversized to fit around the 2” diameter grommets shaft flange plate wire access hole.

After fabrication, have steel poles, required mast arms, and all parts used in the assembly hot-dip galvanized per section 1076. Design structural assemblies with weep holes large enough and properly located to drain molten zinc during the galvanization process. Provide hot-dip galvanizing on structures that meets or exceeds ASTM Standard A-123. Provide galvanizing on hardware that meets or exceeds ASTM Standard A-153. Ensure that threaded material is brushed and retapped as necessary after galvanizing. Perform repair of damaged galvanizing that complies with the following:

Repair of Galvanizing.....Article 1076-7

Standard Drawings for Metal Poles are available that supplement these project special provisions. These drawings are located on the Department’s website:

<https://connect.ncdot.gov/resources/safety/pages/ITS-Design-Resources.aspx>

U-4405

TS-45

Cumberland County

Comply with article 1098-1B of the *2018 STANDARD SPECIFICATIONS FOR ROADS & STRUCTURES*, hereinafter referred to as the *Standard Specifications* for submittal requirements. Furnish shop drawings for approval. Provide the copies of detailed shop drawings for each type of structure as summarized below. Ensure that shop drawings include material specifications for each component and identify welds by type and size on the detail drawing only, not in table format. **Do not release structures for fabrication until shop drawings have been approved by NCDOT.** Provide an itemized bill of materials for all structural components and associated connecting hardware on the drawings.

Comply with article 1098-1A of the *Standard Specifications* for Qualified Products List (QPL) submittals. All shop drawings must include project location description, signal inventory number(s) and a project number or work order number on the drawings.

Summary of information required for metal pole review submittal:

Item	Hardcopy Submittal	Electronic Submittal	Comments / Special Instructions
Sealed, Approved Signal Plan/Loading Diagram	1	1	All structure design information needs to reflect the latest approved signal plans
Custom Pole Shop Drawings	4 sets	1 set	Show NCDOT inventory number(s), contractor's name and relevant revision number in the title block. All drawings must have a <u>unique drawing number</u> for each project and identified for multiple pages.
Standard Pole Shop Drawings (from the QPL)	4 sets	1 set	Submit drawings on 11" x 17" format media. Show NCDOT inventory number(s), contractor's name and relevant revision number in the title block. All drawings must have a <u>unique drawing number</u> for each project and identified for multiple pages.
Structure Calculations	1 set	1 set	Not required for Standard QPL Poles
Standard Pole Foundation Drawings	1 set	1 set	Submit drawings on 11" x 17" format media. Submit a completed Standard Foundation Selection form for each pole using foundation table on Metal Pole Drawing M-8.
Custom Foundation Drawings	4 sets	1 set	Submit drawings on 11" x 17" format media. Show NCDOT inventory number(s), contractor's name and relevant revision number in the title block. All drawings must have a <u>unique drawing number</u> for each project and identified for multiple pages.  If QPL Poles are used, include the corresponding QPL pole shop drawings with this submittal.

U-4405

TS-46

Cumberland County

Foundation Calculations	1	1	<b>Submit copies of LPILE input, output, and pile tip deflection graph per Section 11.4 of this specification for each foundation.</b>  Not required for Standard QPL Poles
Soil Boring Logs and Report	1	1	Report should include a location plan and a soil classification report including soil capacity, water level, hammer efficiency, soil bearing pressure, soil density, etc. for each pole.

**NOTE** – All shop drawings and custom foundation design drawings must be sealed by a Professional Engineer licensed in the state of North Carolina. All geotechnical information must be sealed by either a Professional Engineer or geologist licensed in the state of North Carolina. Include a title block and revision block on the shop drawings and foundation drawings showing the NCDOT inventory number.

**Shop drawings and foundation drawings may be submitted together or separately for approval. However, shop drawings must be approved before foundations can be reviewed.** Foundation designs will be returned without review if the associated shop drawing has not been approved. Boring reports should include the following: Engineer's summary, boring location maps, soil classification per AASHTO Classification System, hammer efficiency, and Metal Pole Standard Foundation Selection Form. Incomplete submittals will be returned without review. The Reviewer has the right to request additional analysis and copies of the calculations to expedite the approval process.

#### **B. Materials:**

Fabricate metal pole and arm shaft from coil or plate steel to meet the requirements of ASTM A 595 Grade A tubes. For structural steel shapes, plates and bars use A572 Gr 50 min or ASTM A709 Gr 50 min. Provide pole and arm shafts that are round in cross section or multisided tubular shapes and have a uniform linear taper of 0.14 in/ft. Construct shafts from one piece of single ply plate or coil so there are no circumferential weld splices. Galvanize in accordance with AASHTO M 111 or an approved equivalent.

Use the submerged arc process or other NCDOT previously approved process suitable for pole shaft and arms to continuously weld pole shafts and arm shafts along their entire length. The longitudinal seam weld will be finished flush to the outside contour of the base metal. Ensure shafts have no circumferential welds except at the lower end joining the shaft to the pole base and arm base. Use full penetration groove welds with backing ring for all tube-to-transverse-plate connections in accordance with 6<sup>th</sup> Edition AASHTO. Provide welding that conforms to Article 1072-18 of the *Standard Specifications*, except that no field welding on any part of the pole will be permitted unless approved by a qualified engineer.

Refer to Metal Pole Standard Drawing Sheets M2 through M5 for fabrication details. Fabricate anchor bases and mast arm connecting plates from plate steel meeting, as a minimum, the requirements of ASTM A572 Gr 50, AASHTO M270 Gr 50, ASTM A709 Gr50, or an approved equivalent. Conform to the applicable bolt pattern and orientation as shown on Metal Pole Standard Drawing Sheet M2.

Ensure all hardware is galvanized steel or stainless steel. The Contractor is responsible for ensuring that the designer/fabricator specifies connecting hardware and/or materials that do not create a dissimilar metal corrosive reaction.

Provide a minimum of four (4) 1-1/2" diameter high strength bolts for connection between arm plate and pole plate. Increase number of bolts to six (6) 1-1/2" diameter high strength bolts when arm lengths are greater than 50'-0" long.

Unless otherwise required by the design, ensure each anchor rod is 2" diameter and 60" length. Provide 10" minimum thread projection at the top of the rod, and 8" minimum at the bottom of the rod. Use anchor rod assembly and drilled pier foundation materials that meet the *Foundations and Anchor Rod Assemblies for Metal Poles* provision.

For each structural bolt and other steel hardware, hot dip galvanizing shall conform to the requirements of AASHTO M 232 (ASTM A 153). Ensure end caps for poles or mast arms are constructed of cast aluminum conforming to Aluminum Alloy 356.0F.

Provide a circular anchor bolt lock plate that will be secured to the anchor bolts at the embedded end with 2 washers and 2 nuts. Provide a base plate template that matches the bolt circle diameter of the anchor bolt lock plate. Construct plates and templates from 1/4" minimum thick steel with a minimum width of 4". Galvanizing is not required for both plates.

Provide 4 heavy hex nuts and 4 flat washers for each anchor bolt. For nuts, use AASHTO M291 grade 2H, DH, or DH3 or equivalent material. For flat washers, use AASHTO M293 or equivalent material.

### C. Construction Methods:

Erect signal support poles only after concrete has attained a minimum allowable compressive strength of 3000 psi. Install anchor rod assemblies in accordance with the *Foundations and Anchor Rod Assemblies for Metal Poles* provision.

For further construction methods, see construction methods for Metal Strain Pole, or Metal Pole with Mast Arm.

Connect poles to grounding electrodes and bond them to the electrical service grounding electrodes.

For holes in the poles used to accommodate cables, install grommets before wiring pole or arm. Do not cut or split grommets.

Attach the terminal compartment cover to the pole by a sturdy chain or cable. Ensure the chain or cable is long enough to permit the cover to hang clear of the compartment opening when the cover is removed, and is strong enough to prevent vandalism. Ensure the chain or cable will not interfere with service to the cables in the pole base.

Attach cap to pole with a sturdy chain or cable. Ensure the chain or cable is long enough to permit the cap to hang clear of the opening when the cap is removed.

Perform repair of damaged galvanizing that complies with the *Standard Specifications*, Article 1076-7 "Repair of Galvanizing."

Install galvanized wire mesh around the perimeter of the base plate to cover the gap between the base plate and top of foundation for debris and pest control.

Install a 1/4" thick plate for concrete foundation tag to include: concrete grade, depth, diameter, and reinforcement sizes of the installed foundation.

## 5.2. METAL POLE UPRIGHTS (VERTICAL MEMBERS)

### A. Materials:

- Provide tapered tubular shafts and fabricated of steel conforming to ASTM A-595 Grade A or an approved equivalent.
- Hot-dip galvanize poles in accordance with AASHTO M 111 or an approved equivalent.
- Have shafts that are continuously welded for the entire length by the submerged arc process, and with exposed welds ground or rolled smooth and flush with the base metal. Provide welding that conforms to Article 1072-18 of the *Standard Specification* except that no field welding on any part of the pole will be permitted.
- Have Shafts with no circumferential welds except at the lower end joining the shaft to the base.
- Have anchor bases for steel poles fabricated from plate steel meeting as a minimum the requirements of ASTM A572 Gr 50, AASHTO M270 Gr 50, ASTM A709 Gr 50, or an approved equivalent.

Provide a grounding lug(s) in the approximate vicinity of the messenger cable clamp for bonding and grounding messenger cable. Lugs must accept #4 or #6 AWG wire to bond messenger cables to the pole in order to provide an effective ground fault circuit path. Refer to Metal Pole Standard Drawing Sheet M6 for construction details.

Have poles permanently stamped above the hand holes with the identification tag details as shown on Metal Pole Standard Drawing Sheet M2.

Provide liquid tight flexible metal conduit (Type LFMC), liquid tight flexible nonmetallic conduit (Type LFNC), high density polyethylene conduit (Type HDPE), or approved equivalent to isolate conductors feeding luminaires.

Fabricate poles from a single piece of steel or aluminum with single line seam weld with no transverse butt welds. Fabrication of two ply pole shafts is unacceptable with the exception of fluted shafts. Provide tapers for all shafts that begin at base and that have diameters which decrease uniformly at the rate of not more than 0.14 inch per foot (11.7 millimeters per meter) of length.

Provide four anchor nuts and four washers for each anchor bolt. Ensure that anchor bolts have required diameters, lengths, and positions, and will develop strengths comparable to their respective poles.

Provide a terminal compartment with cover and screws in each pole that encompasses the hand hole and contains a 12-terminal barrier type terminal block. Provide two terminal screws with a removable shorting bar between them for each termination. Furnish terminal compartment covers attached to the pole by a sturdy chain or cable approved by the Engineer. Ensure that the chain or cable is long enough to permit the cover to hang clear of the compartment opening when the cover is removed, and is strong enough to prevent vandals from being able to disconnect the cover from the pole. Ensure that the chain or cable will not interfere with service to the cables in the pole base.

Install grounding lugs that will accept #4 or #6 AWG wire to electrically bond messenger cables to the pole. Refer to Metal Pole Standard Drawing Sheet M6 for construction details.



U-4405

TS-49

Cumberland County

For each pole, provide a 1/2-inch minimum thread diameter, coarse thread stud and nut for grounding which will accommodate #6 AWG ground wire. Ensure that the lug is electrically bonded to the pole and is conveniently located inside the pole at the hand hole.

Provide a removable pole cap with stainless steel attachment screws for the top of each pole. Ensure that the cap is cast aluminum conforming to Aluminum Association Alloy 356.0F. Furnish cap attached to the pole with a sturdy chain or cable approved by the Engineer. Ensure that the chain or cable is long enough to permit the cap to hang clear of the pole-top opening when the cap is removed.

When required by the plans, furnish couplings 42 inches above the bottom of the base for mounting of pedestrian pushbuttons. Provide mounting points consisting of 1-1/2 inch internally threaded half-couplings that comply with the NEC and that are mounted within the poles. Ensure that couplings are essentially flush with the outside surfaces of the poles and are installed before any required galvanizing. Provide a threaded plug in each mounting point. Ensure that the surface of the plug is essentially flush with the outer end of the mounting point when installed and has a recessed hole to accommodate a standard wrench.

#### 1. Strain Pole Shafts

Provide 2 messenger cable (span wire) clamps and associated hardware for attachment of messenger cable. Ensure that diameter of the clamp is appropriate to its location on the pole and is appropriately designed to be adjustable from 1'-6" below the top, down to 6'-6" below the top of the pole. Do not attach more than one support cable to a messenger cable clamp.

Provide a minimum of three (3) 2-inch (50 mm) holes equipped with an associated coupling and weatherhead on the messenger cable load side of the pole to accommodate passage of signal cables from inside the pole. Provide galvanized threaded plugs for all unused couplings at pole entrance points. Refer to Metal Pole Standard Drawing Sheet M3 for fabrication details.

Ensure that allowable pole deflection does not exceed that allowed per 6<sup>th</sup> Edition AASHTO. Ensure maximum deflection at the top of the pole does not exceed 2.5 percent of the pole height.

#### B. Construction Methods:

Install metal poles, hardware, and fittings as shown on the manufacturer's installation drawings. Install metal poles so that when the pole is fully loaded it is within 1 degree 40 minutes (1°40') of vertical. Install poles with the manufacturer's recommended "rake." Use threaded leveling nuts to establish rake if required.

#### 5.3. DRILLED PIER FOUNDATIONS FOR METAL TRAFFIC SIGNAL POLES

Analysis procedures and formulas shall be based on AASHTO 6<sup>th</sup> Edition, latest ACI code and the *Drilled Shafts: Construction Procedures and Design Methods* FHWA-NHI-10-016 manual. Design methods based on engineering publications or research papers needs to have prior approval from NCDOT. The Department reserves the right to accept or disapprove any method used for the analysis.

Use a Factor of Safety of 1.33 for torsion and 2.0 for bending for the foundation design.

Foundation design for lateral load shall not exceed 1" lateral deflection at top of foundation.

For lateral analysis, use LPILE Plus V6.0 or later. Inputs, results, and corresponding graphs are to be submitted with the design calculations.

U-4405

TS-50

Cumberland County

Skin Friction is to be calculated using the  $\alpha$ -method for cohesive soils and the  $\beta$ -method for cohesion-less soils (**Broms method will not be accepted**). Detailed descriptions of the “ $\alpha$ ” and “ $\beta$ ” methods can be found in *FHWA-NHI-10-016*.

Omit first 2.5ft for cohesive soils when calculating skin friction.

When hammer efficiency is not provided, assume a value of 0.70.

Design all custom foundations to carry the maximum capacity of each metal pole. For standard case strain poles only, if a custom foundation is designed, use the actual shear, axial and moment reactions from the Standard Foundation Selection Table shown on Standard Drawing No. M8.

When poor soil conditions are encountered which could create an excessively large foundation design, consideration may be given to allowing an exemption to the maximum capacity design. The contractor must gain approval from the engineer before reducing a foundation’s capacity. On projects where poor soil is known to be present, it is advisable that the contractor consider getting foundations approved before releasing poles for fabrication.

Have the contractor notify the engineer if the proposed foundation is to be installed on a slope other than 8H: 1V or flatter.

#### **A. Description:**

Furnish and install foundations for NCDOT metal poles with all necessary hardware in accordance with the plans and specifications.

Metal Pole Standards have been developed and implemented by NCDOT for use at signalized intersections in North Carolina. If the plans call for a standard pole, then a standard foundation may be selected from the plans. However, the Contractor is not required to use a standard foundation. If the Contractor chooses to design a non-standard site-specific foundation for a standard pole or if the plans call for a non-standard site-specific pole, design the foundation to conform to the applicable provisions in the NCDOT Metal Pole Standard Drawings and Section B7 (Non-Standard Foundation Design) below. If non-standard site-specific foundations are designed for standard QPL approved strain poles, the foundation designer must use the design moment specified by load case on Metal Pole Standard Drawing Sheet M8. Failure to conform to this requirement will be grounds for rejection of the design.

If the Contractor chooses to design a non-standard foundation for a standard pole and the soil test results indicate a standard foundation is feasible for the site, the Contractor will be paid the cost of the standard foundation (drilled pier and wing wall, if applicable). Any additional costs associated with a non-standard site-specific foundation including additional materials, labor and equipment will be considered incidental to the cost of the standard foundation. All costs for the non-standard foundation design will also be considered incidental to the cost of the standard foundation.

#### **B. Soil Test and Foundation Determination:**

##### **1. General:**

Drilled piers are reinforced concrete sections, cast-in-place against in situ, undisturbed material. Drilled piers are of straight shaft type and vertical.

Some standard drilled piers for supporting poles with mast arms may require wing walls to resist torsional rotation. Based upon this provision and the results of the required soil test, a drilled pier length and wing wall requirement may be determined and constructed in accordance with the plans.

U-4405

TS-51

Cumberland County

For non-standard site-specific poles, the contractor-selected pole fabricator will determine if the addition of wing walls is necessary for the supporting foundations.

## 2. Soil Test:

Perform a soil test at each proposed metal pole location. Complete all required fill placement and excavation at each signal pole location to finished grade before drilling each boring. Soil tests performed that are not in compliance with this requirement may be rejected and will not be paid. Drill one boring to a depth of 26 feet within a 25-foot radius of each proposed foundation.

Perform standard penetration tests (SPT) in accordance with ASTM D 1586 at depths of 1, 2.5, 5, 7.5, 10, 15, 20 and 26 feet. Discontinue the boring if one of the following occurs:

- A total of 100 blows have been applied in any 2 consecutive 6-in. intervals.
- A total of 50 blows have been applied with < 3-in. penetration.

Describe each intersection as the “Intersection of (Route or SR #), (Street Name) and (Route or SR #), (Street Name), \_\_\_\_\_ County, Signal Inventory No. \_\_\_\_\_”. Label borings with “B- N, S, E, W, NE, NW, SE or SW” corresponding to the quadrant location within the intersection. Pole numbers should be made available to the Drill Contractor. Include pole numbers in the boring label if they are available. If they are not available, ensure the boring labels can be cross-referenced to corresponding pole numbers. For each boring, submit a legible (hand written or typed) boring log signed and sealed by a licensed Geologist or Professional Engineer registered in North Carolina. Include on each boring the SPT blow counts and N-values at each depth, depth of the boring, hammer efficiency, depth of water table and a general description of the soil types encountered using the AASHTO Classification System.

## 3. Standard Foundation Determination:

Use the following method for determining the Design N-value:

$$N_{AVG} = \frac{(N@1' + N@2.5' + \dots + N@Deepest \text{ Boring Depth})}{\text{Total Number of N-values}}$$

$$Y = (N@1')^2 + (N@2.5')^2 + \dots + (N@Deepest \text{ Boring Depth})^2$$

$$Z = (N@1' + N@2.5' + \dots + N@Deepest \text{ Boring Depth})$$

$$N_{STD DEV} = \left[ \frac{(\text{Total Number of N-values} \times Y) - Z^2}{(\text{Total Number of N-values}) \times (\text{Total Number of N-values} - 1)} \right]^{0.5}$$

**Design N-value** equals lesser of the following two conditions:

$$N_{AVG} - (N_{STD DEV} \times 0.45)$$

Or

$$\text{Average of First Four N-Values} = \frac{(N@1' + N@2.5' + N@5' + N@7.5')}{4}$$

4

*Note: If less than 4 N-values are obtained because of criteria listed in Section 2 above, use average of N-values collected for second condition. Do not include the N-value at the deepest boring depth for above calculations if the boring is discontinued at or before the required boring depth because of criteria listed in Section 2 above. Use N-value of zero for weight of hammer or weight of rod. If N-value is greater than 50, reduce N-value to 50 for calculations.*

If standard NCDOT strain poles are shown on the plans and the Contractor chooses to use standard foundations, determine a drilled pier length, "L," for each signal pole from the Standard Foundations Chart (sheet M 8) based on the Design N-value and the predominant soil type. For each standard pole location, submit a completed "Metal Pole Standard Foundation Selection Form" signed by the Contractor's representative. Signature on form is for verification purposes only. Include the Design N-value calculation and resulting drilled pier length, "L," on each form.

If non-standard site-specific poles are shown on the plans, submit completed boring logs collected in accordance with Section 2 (Soil Test) above along with pole loading diagrams from the plans to the contractor-selected pole fabricator to assist in the pole and foundation design.

If one of the following occurs, the Standard Foundations Chart shown on the plans may not be used and a non-standard foundation may be required. In such case, contact the Engineer.

- The Design N-value is less than 4.
- The drilled pier length, "L", determined from the Standard Foundations Chart, is greater than the depth of the corresponding boring.

In the case where a standard foundation cannot be used, the Department will be responsible for the additional cost of the non-standard foundation.

Foundation designs are based on level ground around the traffic signal pole. If the slope around the edge of the drilled pier is steeper than 8:1 (H:V) or the proposed foundation will be less than 10 feet from the top of an embankment slope, the Contractor is responsible for providing slope information to the foundation designer and to the Engineer, so it can be considered in the design.

The "Metal Pole Standard Foundation Selection Form" may be found at:

<http://www.ncdot.gov/doh/preconstruct/highway/geotech/formdet/misc/MetalPole.pdf>

If assistance is needed, contact the Engineer.

#### **4. Non-Standard Foundation Design:**

Design non-standard foundations based upon site-specific soil test information collected in accordance with Section 2 (Soil Test) above. Design drilled piers for side resistance only in accordance with Section 4.6 of the *AASHTO Standard Specifications for Highway Bridges*. Use the computer software LPILE version-6.0 or later manufactured by Ensoft, Inc. to analyze drilled piers. Use the computer software gINT V8i or later manufactured by Bentley Systems, Inc. with the current NCDOT gINT library and data template to produce SPT boring logs. Provide a drilled pier foundation for each pole with a length and diameter that result in a horizontal lateral movement of less than 1 inch at the top of the pier and a horizontal rotational movement of less than 1 inch at the edge of the pier. Contact the Engineer for pole loading diagrams for standard poles to be used for non-standard foundation designs. Submit any non-standard foundation designs including drawings, calculations, and soil boring logs to the Engineer for review and approval before construction.

U-4405

TS-53

Cumberland County

**C. Drilled Pier Construction:**

Construct drilled pier foundations in accordance with the *Foundations and Anchor Rod Assemblies for Metal Poles* provision.

**5.4. METAL SIGNAL POLE REMOVALS****A. Description:**

Remove and dispose of existing metal signal poles, and remove and dispose of existing foundations, associated anchor bolts, electrical wires, and connections.

**B. Construction Methods:****1. Foundations:**

Remove and promptly dispose of the metal signal pole foundations including reinforcing steel, electrical wires, and anchor bolts to a minimum depth of two feet below the finished ground elevation. At the Contractor's option, remove the complete foundation.

**2. Metal Poles:**

Assume ownership of the metal signal poles, remove the metal signal poles, and promptly transport the metal signal poles from the project. Use methods to remove the metal signal poles and attached traffic signal equipment that will not result in damage to other portions of the project or facility. Repair damages that are a result of the Contractor's actions at no additional cost to the Department.

Transport and properly dispose of the materials.

Backfill and compact disturbed areas to match the finished ground elevation. Seed unpaved areas.

Use methods to remove the foundations that will not result in damage to other portions of the project or facility. Repair damages that are a result of the Contractor's actions at no cost to the Department.

**5.5. POLE NUMBERING SYSTEM****A. New Poles**

Attach an identification tag to each pole shaft and mast arm section as shown on Metal Pole Standard Drawing Sheet M2 "Typical Fabrication Details Common To All Metal Poles".

**5.6. MEASUREMENT AND PAYMENT**

Actual number of metal strain signal poles (without regard to height or load capacity) furnished, installed, and accepted.

Actual number of soil tests with SPT borings drilled furnished and accepted.

Actual volume of concrete poured in cubic yards of drilled pier foundation furnished, installed, and accepted.

Actual number of metal signal pole foundations removed and disposed.

Actual number of metal signal poles removed and disposed.

**U-4405**

**TS-54**

**Cumberland County**

No measurement will be made for foundation designs prepared with metal pole designs, as these will be considered incidental to designing signal support structures.

**Payment will be made under:**

Metal Strain Signal Pole.....	Each
Soil Test.....	Each
Drilled Pier Foundation.....	Cubic Yard
Metal Pole Foundation Removal.....	Each
Metal Pole Removal.....	Each

**6. BACK PULL FIBER OPTIC CABLE**

**6.1. DESCRIPTION**

Back pull and store or back pull and reinstall existing communications cable.

**6.2. CONSTRUCTION**

During project construction where instructed to back pull existing aerial sections of fiber optic communications cable, de-lash the cable from the messenger cable and back pull the cable to a point where it can be stored or re-routed as shown on the plans. If instructed, remove, and discard the existing messenger cable and pole mounting hardware once the cable is safely out of harm’s way.

During project construction where instructed to back pull existing underground sections of fiber optic communications cable, back pull the cable to a point where it can be stored or re-routed as shown on the plans. If instructed, remove abandoned junction boxes, and backfill with a suitable material to match the existing grade. Leave abandoned conduits in place unless otherwise noted.

Where instructed, re-pull the fiber optic cable back along messenger cable or through conduit systems.

**6.3. MEASUREMENT AND PAYMENT**

*Back Pull Fiber Optic Cable* will be paid for as the actual linear feet of fiber optic cable back pulled and either stored or back pulled and rerouted. Payment is for the actual linear feet of cable back pulled.

No payment will be made for removing messenger cable and pole mounting hardware or removing junction boxes and back filling to match the surrounding grade as these items of work will be considered incidental to back pulling the fiber optic cable.

Payment will be made under:

Back Pull Fiber Optic Cable .....	Linear Feet
-----------------------------------	-------------

**7. SPLICE CABINETS – FIBER OPTICS**

**7.1. FIBER-OPTIC SPLICE CABINET (BASE MOUNTED)**

**A. Description**

Furnish and install splice cabinets and all necessary hardware in accordance with the plans and specifications for the purpose of splicing and terminating fiber-optic cable.

U-4405

TS-55

Cumberland County

**B. Materials**

Furnish material, equipment, and hardware furnished under this section that is pre-approved on the ITS and Signals QPL.

Furnish NEMA Type 4 splice cabinets of sufficient size to accommodate the fiber-optic interconnect center. Provide sufficient size so that the equipment installed will not occupy more than 60 percent of the total cabinet volume.

The cabinet housing must conform to sections 6.2.2 (Housing Construction), 6.2.3 (Door Latches and Locks), and 6.2.5 (Hinges and Door Catches) of the CALTRANS TSCES. Do not equip the cabinet housings with a police panel.

The cabinet cage must conform to section 6.3 of the CALTRANS TSCES.

**C. Construction Methods****1. General:**

Locate cabinets so as not to obstruct sight distance of vehicles turning on red.

**2. Base Mounted:**

Install base mounted cabinets as shown on the plans and as approved by the Engineer. Refer to Section 1750 - Signal Cabinet Foundations of the *Standard Specifications* for installation requirements for the foundations. The following exceptions are made:

- Install only the required number of conduits as shown on the plans plus one additional spare stub out conduit.
- Do not provide a 24-inch working area on the backside of the cabinet. Provide only a 24-inch working area measured from the front of the cabinet and 3-inch lip measured from the sides and back of the cabinet.
- All other requirements apply.

**7.2. HUB SPLICE CENTERS****A. Description**

Furnish and install Hub Splice Centers, and all necessary hardware inside the Fiber-optic Splice Cabinets to accommodate the termination and splicing of the trunk cables.

**B. Materials**

Provide a hub splice center for terminating a single trunk fiber-optic cable that consists of a rack-mounted splice housing for the splice trays and a rack-mounted connector housing containing patch panels. Furnish a separate rack-mounted hub splice center for each new trunk fiber-optic communications cable entering and terminated inside the hub cabinet. Provide a hub splice center sized to accommodate fusion splicing of all fibers in the designated cable to pigtails in splice trays housed inside the hub splice center and terminating those pigtails on the hub splice center's connector panels (i.e., patch panels) as shown in the Plans. Equip the connector housings with ST connector panels to terminate fibers from each buffer tube in the incoming cable on a unique connector panel (i.e., one connector panel per buffer tube).

Furnish connector housings and splice housings made by the same manufacturer and designed by the manufacturer to work together as a unit. Provide a hub splice center designed to house a separate

splice tray for each buffer tube in the cable and to store buffer tubes following splicing. Provide splice housings that occupy no more than five rack units.

Provide splice trays that hold, protect, organize optical fibers, and secure fibers inside splice tray. Design and size the splice trays to be dielectric, to accommodate all fibers entering splice tray, and to provide sufficient space to prevent microbending of optical fibers.

Furnish SMFO pigtailed with the hub splice center. Provide pigtailed that are a maximum of six feet in length with factory-assembled ST connectors. Ensure SMFO pigtailed meet the operating characteristics of the SMFO cable with which it is to be coupled. Factory pre-terminated and pre-assembled pigtailed connector panels may be furnished in lieu pigtailed pre-assembled with ST connectors, subject to the Engineer's approval.

Furnish SMFO jumpers to cross-connect cables from one splice panel to another as shown in the plans. Provide jumpers that are a maximum of six feet in length with factory-assembled ST connectors on each end. Ensure SMFO pigtailed meet the operating characteristics of the SMFO cable with which it is to be coupled.

Provide all hardware needed to install these units in the 19-inch EIA rack inside the hub splice cabinet.

### C. Construction Methods

#### 1. General (Workmanship Identification Information)

Include on the cover of each splice tray in a legible format the following workmanship identification information:

- Splice location reference # or identification information (e.g., 06-xxxx tray 1 of 3, 06-xxxx tray 2 of 3, etc.);
- Date the splice was made;
- Name of company that performed the splicing;
- Name of person who performed the splicing.

#### 2. Workmanship

Upon cutting the cable and removing the outer jacketing material down to the individual buffer tubes, secure the central strength member to the enclosure so that no tensile force is applied to the fibers. Secure the individual buffer tubes to the splice trays by a method recommended by the manufacturer. Determine the length of each buffer tube needed to ensure that the buffer tube can be looped a minimum of two times around the inside of the splice tray. Upon determining the length of buffer tube needed, remove the buffer tube to expose the individual fibers for fusion splicing. Adjust individual fiber lengths as necessary to ensure that once the fusion splicing process is completed the finished splices will align with the "splice block organizer" supplied within the splice tray. Ensure the splice block organizer has individual fusion splice space holders for each fiber splice.

While prepping the individual fibers for splicing, install the heat shrink protective tube over the fiber and then perform the splicing operations, following the manufacturer's instructions. Verify that the newly formed splice does not exceed 0.05 dB of attenuation. If the attenuation is more than 0.05 dB, then remake the splice until it meets the 0.05 dB or less requirement. Finish the splicing operation by sliding the heat shrink tube over the splice and applying heat to activate the heat shrink tubing. Secure the finished splice in the splice block organizer. Ensure each splice is properly



secured in a space holder in the splice block organizer. Multiple splices secured to the same space holder are unacceptable.

Ensure all buffer tubes are contained within splice trays so that no bare fibers are outside of the tray. Do not damage the fibers or violate the minimum bend radius of the fiber.

Prior to installing the cover over the splice tray and placing it in its final resting location, take a MANDATORY digital photograph of the splice tray that shows the final workmanship. Ensure that the photograph shows the "Workmanship Identification Information" as well as the workmanship associated with installing and terminating the fiber. Ensure that the photograph is clear, in-focus and information captured is legible. Include digital copies of each photograph on a compact disc as part of the OTDR Test Results submittal.

### **3. Termination and Splicing within Interconnect Centers**

Terminate and fusion splice all fibers as shown in the Plans.

Label all fiber-optic connectors, whether on jumpers, connector panels, or other equipment, to prevent improper connection. Obtain approval of fiber-optic connector labeling method.

For all fibers designated for termination to a connector panel within an interconnect center, fusion splice the fibers to pigtails.

For all fibers designated to pass through interconnect center, neatly coil and express the fibers without cutting. For all buffer tubes designated to pass through interconnect center, neatly coil excess tubing inside interconnect center.

### **4. Termination and Splicing within Hub Splice Center**

Install a hub splice center with connector panels, splice trays, storage for slack cable or fibers, and mounting and strain relief hardware, and all necessary hardware. Mount the hub splice center in the rack inside the hub splice cabinet as shown in the Plans.

Terminate and fusion splice all fibers as shown in the Plans.

Label all fiber-optic connectors, whether on jumpers, connector panels, or other equipment, to prevent improper connection. Obtain approval of fiber-optic connector labeling method.

For all fibers designated for termination to a connector panel within the hub splice center, fusion splice the fibers to pigtails.

For all fibers designated to pass through hub splice center, neatly coil, and express the fibers without cutting. For all buffer tubes designated to pass through hub splice center, neatly coil excess tubing inside hub splice center without cutting.

Install SMFO jumpers to cross-connect between the appropriate connectors on the various connector panels in the Fiber-Optic Splice cabinet.

### **5. Testing**

Provide written notification to the Engineer a minimum of 10 working days before beginning the OTDR tests.

After splicing is completed, perform bi-directional OTDR tests on each fiber, including unused fibers. Install a 1,000-foot pre-tested launch cable between the OTDR and fiber-optic cable to be tested and a 1,000-foot pre-tested destination cable on the end of the fiber-optic cable to be tested. Ensure each launch cable has been tested and is compatible with the fiber-optic cable being installed.

Provide the Engineer with test results of the launch cable before use. Retest or replace launch cable at the Engineer's request.

Ensure fusion splice losses do not exceed 0.05 dB and connectors have a loss of 0.5 dB or less. If any fiber exceeds maximum allowable attenuation or if fiber-optic properties of the cable have been impaired, take appropriate actions up to and including replacement of the fiber-optic cable. Corrective action will be at no additional cost to the Department.

Clearly label each OTDR trace identifying a starting and ending point for all fibers being tested. Record the attenuation level of each fiber and clearly indicate OTDR trace results in report format. Furnish two hard copies of each of the OTDR trace results and electronic copies of all trace results along with digital photographs showing workmanship for each splice on a compact disc. Furnish the manufacturer's make, model number and software version of the OTDR used for testing.

Provide the Engineer with two copies of the software needed to view the OTDR traces electronically.

**7.3. MEASUREMENT AND PAYMENT**

*Fiber-optic Splice Cabinets (base mounted)* will be measured and paid by the actual number of furnished, installed, and accepted.

No measurement will be made for the cabinet foundation as it will be covered under Section 1750 – Signal Cabinet Foundations of the *Standard Specifications*.

*Hub Splice Centers* will be measured and paid by the actual number of fiber-optic hub splice centers that are furnished, installed, and accepted.

No measurement will be made of fusion splices, splice trays, splice protectors, pigtails, jumpers, connector panels, labeling, photographs, testing and corrective actions, repairs and replacements needed due to exceeding the maximum allowable attenuation or other defects, as these will be considered incidental to furnishing and installing fiber-optic interconnect centers, hub splice centers and splice enclosures.

Payment will be made under:

Fiber-optic Splice Cabinet (Base Mounted) .....	Each
Hub Splice Center .....	Each

**8. ETHERNET EDGE SWITCH**

Furnish and install a managed Ethernet edge switch as specified below that is fully compatible, interoperable, and completely interchangeable and functional within the existing City or Division traffic signal system communications network.

**8.1. DESCRIPTION**

**A. Ethernet Edge Switch:**

Furnish and install a hardened, field Ethernet edge switch (hereafter "edge switch") for traffic signal controllers as specified below. Install an Ethernet edge switch in all new cabinets and furnish an Ethernet edge switch for each spare cabinet. Ensure that the edge switch provides wire-speed, fast Ethernet connectivity at transmission rates of 100 megabits per second from each remote ITS device location to the routing switches.

U-4405

TS-59

Cumberland County

Contact the City or Division to arrange for the programming of the new Field Ethernet Switches with the necessary network configuration data, including but not limited to, the Project IP Address, Default Gateway, Subnet Mask and VLAN ID information. Provide a minimum five (5) days working notice to allow the City or Division to program the new devices.

### **B. Network Management:**

Ensure that the edge switch is fully compatible with the City's or Division's existing Network Management Software.

### **8.2. MATERIALS**

#### **A. General:**

Ensure that the edge switch is fully compatible and interoperable with the trunk Ethernet network interface and that the edge switch supports half and full duplex Ethernet communications.

Furnish an edge switch that provide 99.999% error-free operation, and that complies with the Electronic Industries Alliance (EIA) Ethernet data communication requirements using single-mode fiber-optic transmission medium and copper transmission medium. Ensure that the edge switch has a minimum mean time between failures (MTBF) of 10 years, or 87,600 hours, as calculated using the Bellcore/Telcordia SR-332 standard for reliability prediction.

#### **B. Compatibility Acceptance**

The Engineer has the authority to require the Contractor to submit a sample Field Ethernet Switch and Field Ethernet Transceiver along with all supporting documentation, software, and testing procedures to allow a compatibility acceptance test to be performed prior to approving the proposed Field Ethernet Switch and Field Ethernet Transceiver for deployment. **The Compatibility Acceptance testing will ensure that the proposed device is 100% compatible and interoperable with the existing City Signal System network, monitoring software and Traffic Operations Center network hardware.** Allow fifteen (15) working days for the Compatibility Acceptance Testing to be performed

#### **C. Standards:**

Ensure that the edge switch complies with all applicable IEEE networking standards for Ethernet communications, including but not limited to:

- IEEE 802.1D standard for media access control (MAC) bridges used with the Spanning Tree Protocol (STP);
- IEEE 802.1Q standard for port-based virtual local area networks (VLANs);
- IEEE 802.1P standard for Quality of Service (QoS);
- IEEE 802.1w standard for MAC bridges used with the Rapid Spanning Tree Protocol (RSTP);
- IEEE 802.1s standard for MAC bridges used with the Multiple Spanning Tree Protocol;
- IEEE 802.1x standard for port based network access control, including RADIUS;
- IEEE 802.3 standard for local area network (LAN) and metropolitan area network (MAN) access and physical layer specifications;
- IEEE 802.3u supplement standard regarding 100 Base TX/100 Base FX;

- IEEE 802.3x standard regarding flow control with full duplex operation; and
- IFC 2236 regarding IGMP v2 compliance.
- IEEE 802.1AB Link Layer Discovery Protocol (LLDP)
- IEEE 802.3ad Ethernet Link Aggregation
- IEEE 802.3i for 10BASE-T (10 Mbit/s over Fiber-Optic)
- IEEE 802.3ab for 1000BASE-T (1Gbit/s over Ethernet)
- IEEE 802.3z for 1000BASE-X (1 Gbit/s Ethernet over Fiber-Optic)

**D. Functional:**

Ensure that the edge switch supports all Layer 2 management features and certain Layer 3 features related to multicast data transmission and routing. These features shall include, but not be limited to:

- An STP healing/convergence rate that meets or exceeds specifications published in the IEEE 802.1D standard.
- An RSTP healing/convergence rate that meets or exceeds specifications published in the IEEE 802.1w standard.
- An Ethernet edge switch that is a port-based VLAN and supports VLAN tagging that meets or exceeds specifications as published in the IEEE 802.1Q standard, and has a minimum 4-kilobit VLAN address table (254 simultaneous).
- A forwarding/filtering rate that is a minimum of 14,880 packets per second for 10 megabits per second and 148,800 packets per second for 100 megabits per second.
- A minimum 4-kilobit MAC address table.
- Support of Traffic Class Expediting and Dynamic Multicast Filtering.
- Support of, at a minimum, snooping of Version 2 & 3 of the Internet Group Management Protocol (IGMP).
- Support of remote and local setup and management via telnet or secure Web-based GUI and command line interfaces.
- Support of the Simple Network Management Protocol version 3 (SNMPv3). Verify that the Ethernet edge switch can be accessed using the resident EIA-232 management port, a telecommunication network, or the Trivial File Transfer Protocol (TFTP).
- Port security through controlling access by the users. Ensure that the Ethernet edge switch has the capability to generate an alarm and shut down ports when an unauthorized user accesses the network.
- Support of remote monitoring (RMON-1 & RMON-2) of the Ethernet agent.
- Support of the TFTP and SNTP. Ensure that the Ethernet edge switch supports port mirroring for troubleshooting purposes when combined with a network analyzer.

**E. Physical Features:**

*Ports:* Provide 10/100/1000 Mbps auto-negotiating ports (RJ-45) copper Fast Ethernet ports for all edge switches. Provide auto-negotiation circuitry that will automatically negotiate the highest possible data rate and duplex operation possible with attached devices supporting the IEEE 802.3 Clause 28 auto-negotiation standard.

*Optical Ports:* Ensure that all fiber-optic link ports operate at 1310 or 1550 nanometers in single mode. Provide Type LC connectors for the optical ports, as specified in the Plans or by the Engineer. Do not use mechanical transfer registered jack (MTRJ) type connectors.

Provide an edge switch having a minimum of two optical 100/1000 Base X ports capable of transmitting data at 100/1000 megabits per second. Ensure that each optical port consists of a pair of fibers; one fiber will transmit (TX) data and one fiber will receive (RX) data. Ensure that the optical ports have an optical power budget of at least 15 dB.

*Copper Ports:* Provide an edge switch that includes a minimum of four copper ports. Provide Type RJ-45 copper ports and that auto-negotiate speed (i.e., 10/100/1000 Base) and duplex (i.e., full or half). Ensure that all 10/100/1000 Base TX ports meet the specifications detailed in this section and are compliant with the IEEE 802.3 standard pinouts. Ensure that all Category 5E unshielded twisted pair/shielded twisted pair network cables are compliant with the EIA/TIA-568-B standard.

*Port Security:* Ensure that the edge switch supports/complies with the following (remotely) minimum requirements:

- Ability to configure static MAC addresses access;
- Ability to disable automatic address learning per ports; know hereafter as Secure Port. Secure Ports only forward; and
- Trap and alarm upon any unauthorized MAC address and shutdown for programmable duration. Port shutdown requires administrator to manually reset the port before communications are allowed.

**F. Management Capabilities:**

Ensure that the edge switch supports all Layer 2 management features and certain Layer 3 features related to multicast data transmission and routing. These features shall include, but not be limited to:

- An STP healing/convergence rate that meets or exceeds specifications published in the IEEE 802.1 D standards;
- An RSTP healing/convergence rate that meets or exceeds specifications published in the IEEE 802.1w standard;
- An Ethernet edge switch that is a port-based VLAN and supports VLAN tagging that meets or exceeds specifications as published in the IEEE 802.1Q standard, and has a minimum 4-kilobit VLAN address table (254 simultaneous);
- A forwarding/filtering rate that is a minimum of 14,880 packets per second for 10 megabits per second, 148,800 packets per second for 100 megabits per second and 1,488,000 packets per second for 1000 megabits per second;
- A minimum 4-kilobit MAC address table;

U-4405

TS-62

Cumberland County

- Support of Traffic Class Expediting and Dynamic Multicast Filtering.
- Support of, at a minimum, snooping of Version 2 & 3 of the Internet Group Management Protocol (IGMP);
- Support of remote and local setup and management via telnet or secure Web-based GUI and command line interfaces; and
- Support of the Simple Network Management Protocol (SNMP). Verify that the Ethernet edge switch can be accessed using the resident EIA-232 management port, a telecommunication network, or the Trivial File Transfer Protocol (TFTP).

*Network Capabilities:* Provide an edge switch that supports/complies with the following minimum requirements:

- Provide full implementation of IGMPv2 snooping (RFC 2236);
- Provide full implementation of SNMPv1, SNMPv2c, and/or SNMPv3;
- Provide support for the following RMON-I groups, at a minimum:
  - Part 1: Statistics
  - Part 2: History
  - Part 3: Alarm
  - Part 9: Event
- Provide support for the following RMON-2 groups, at a minimum:
  - Part 13: Address Map
  - Part 16: Layer Host
  - Part 17: Layer Matrix
  - Part 18: User History
- Capable of mirroring any port to any other port within the switch;
- Meet the IEEE 802.1Q (VLAN) standard per port for up to four VLANs;
- Meet the IEEE 802.3ad (Port Trunking) standard for a minimum of two groups of four ports;
- Password manageable;
- Telnet/CLI;
- HTTP (Embedded Web Server) with Secure Sockets Layer (SSL); and
- Full implementation of RFC 783 (TFTP) to allow remote firmware upgrades.

*Network Security:* Provide an edge switch that supports/complies with the following (remotely) minimum network security requirements:

- Multi-level user passwords;
- RADIUS centralized password management (IEEE 802.1X);
- SNMPv3 encrypted authentication and access security;
- Port security through controlling access by the users: ensure that the Ethernet edge switch has the capability to generate an alarm and shut down ports when an unauthorized user accesses the network;
- Support of remote monitoring (RMON-1&2) of the Ethernet agent; and

- Support of the TFTP and SNTP. Ensure that the Ethernet edge switch supports port mirroring for troubleshooting purposes when combined with a network analyzer.

### **G. Electrical Specifications:**

Ensure that the edge switch operates, and power is supplied with 115 volts of alternating current (VAC). Ensure that the edge switch has a minimum operating input of 110 VAC and a maximum operating input of 130 VAC. Ensure that if the device requires operating voltages other than 120 VAC, supply the required voltage converter. Ensure that the maximum power consumption does not exceed 50 watts. Ensure that the edge switch has diagnostic light emitting diodes (LEDs), including link, TX, RX, speed (for Category 5E ports only), and power LEDs.

### **H. Environmental Specifications:**

Ensure that the edge switch performs all of the required functions during and after being subjected to an ambient operating temperature range of -30 degrees to 165 degrees Fahrenheit as defined in the environmental requirements section of the NEMA TS 2 standard, with a noncondensing humidity of 0 to 95%.

Provide certification that the device has successfully completed environmental testing as defined in the environmental requirements section of the NEMA TS 2 standard. Provide certification that the device meets the vibration and shock resistance requirements of Sections 2.1.9 and 2.1.10, respectively, of the NEMA TS 2 standard. Ensure that the edge switch is protected from rain, dust, corrosive elements, and typical conditions found in a roadside environment.

The edge switch shall meet or exceed the following environmental standards:

- IEEE 1613 (electric utility substations)
- IEC 61850-3 (electric utility substations)
- IEEE 61800-3 (variable speed drive systems)
- IEC 61000-6-2 (generic industrial)
- EMF – FCC Part 15 CISPR (EN5502) Class A

### **I. Ethernet Patch Cable:**

Furnish a factory pre-terminated/pre-connectorized Ethernet patch cable with each edge switch. Furnish Ethernet patch cables meeting the following physical requirements:

- Five (5)-foot length
- Category 5e or better
- Factory-installed RJ-45 connectors on both ends
- Molded anti-snap hoods over connectors
- Gold plated connectors

Furnish Fast Ethernet patch cords meeting the following minimum performance requirements:

- TIA/EIA-568-B-5, Additional Transmission Performance Specifications for 4-pair 100  $\Omega$  Enhanced Category 5 Cabling
- Frequency Range: 1-100 MHz

**U-4405**

**TS-64**

**Cumberland County**

- Near-End Crosstalk (NEXT): 30.1 dB
- Power-sum NEXT: 27.1 dB
- Attenuation to Crosstalk Ratio (ACR): 6.1 dB
- Power-sum ACR: 3.1 dB
- Return Loss: 10dB
- Propagation Delay: 548 nsec

**8.3. CONSTRUCTION METHODS**

**A. General:**

Ensure that the edge switch is UL listed.

Verify that network/field/data patch cords meet all ANSI/EIA/TIA requirements for Category 5E and Category 6 four-pair unshielded twisted pair cabling with stranded conductors and RJ45 connectors.

Contact the Signal Shop a minimum of 5 days prior to installation for the most current edge switch IP Address, VLAN, subnet mask, default gateway and configuration files.

**B. Edge Switch:**

Mount the edge switch inside each field cabinet by securely fastening the edge switch to the upper end of the right rear vertical rail of the equipment rack using manufacturer-recommended or Engineer-approved attachment methods, attachment hardware and fasteners.

Ensure that the edge switch is mounted securely in the cabinet and is fully accessible by field technicians without blocking access to other equipment. Verify that fiber-optic jumpers consist of a length of cable that has connectors on both ends, primarily used for interconnecting termination or patching facilities and/or equipment.

**8.4. MEASUREMENT AND PAYMENT**

*Ethernet edge switch* will be measured and paid as the actual number of Ethernet edge switches furnished, installed, and accepted.

No separate measurement will be made for Ethernet patch cable, power cord, mounting hardware, nuts, bolts, brackets, or edge switch programming as these will be considered incidental to furnishing and installing the edge switch.

Payment will be made under:

Ethernet Edge Switch..... Each

**9. DMS ELECTRICAL SERVICE**

**9.1. DESCRIPTION**

At locations called out in the Plans, install a new electrical service for the new DMS installation, consisting of a new meter base combination panel with main disconnect and separate disconnects for the equipment feeder conductors.



**U-4405****TS-65****Cumberland County**

Comply with the National Electrical Code (NEC), the National Electrical Safety Code (NESC), the *Standard Specifications*, these Project Special Provisions, and all local ordinances. Coordinate all work involving electrical service with the appropriate utility company and the Engineer.

## **9.2. MATERIALS**

### **A. Electrical Service**

Provide material, equipment and hardware under this section that is pre-approved on the 2018 ITS and Signals QPL by the date of equipment installation.

Provide all materials necessary to form a complete electrical service assembly as shown in the Plans. Furnish new electrical service disconnects, meter bases, and required grounding. Install new feeder conductors in conduits between the meter service and equipment cabinets as required.

Furnish a NEMA 3R combination panel rated for a minimum of 200 Ampere minimum for underground service entrances that meets the requirements of the local utility. Provide meter base with ampere rating of meter sockets based on sockets being wired with insulated wire rated at least 167°F. Ensure the assembly is marked as being suitable for use as service equipment. Ensure combination meter and disconnect mounted in a pedestal for underground service is listed as meeting UL Standard UL-231. Otherwise, ensure combination meter and disconnect is listed as meeting UL Standard UL-67.

Furnish 4 terminal, 600 volt, single phase, 3 wire meter base that complies with the following:

- Line, Load, and Neutral Terminals accept #8 to 4/0 AWG copper/aluminum wire;
- Ringed or Ringless Type, with or without bypass;
- Made of galvanized steel;
- Listed as meeting UL Standard UL-414; and
- Overhead or underground service entrance as specified.

Provide electrical service enclosures, meter bases, disconnect panels, combination panel enclosures and pedestals with electrostatically applied dry powder paint finish with minimum thickness of 2.4 mils and that is light gray in color. All exterior surfaces must be powder coated steel. Provide combination panels with pedestals of sufficient length to attain a minimum embedment depth of 24 inches below grade when installed per the manufacturer's instructions. With each meter base, provide a blank meter socket cover made from UV stabilized polycarbonate or metal and that is either clear or gray in color to prevent access to interior of meter base until meter is installed by the local power company.

Ensure all circuits breakers are rated for at least 10,000 RMS symmetrical amperes short circuit current rating in a lockable NEMA 3R enclosure. Obtain a calculated Arc-Fault current rating value from the electrical company and ensure the supplied breakers comply with the calculated Arc-Fault current rating per the National Electrical Code. Provide new meter base/disconnect combination panels that have a minimum of eight (8) spaces in the disconnect.

Provide a main circuit breaker rated for a minimum of 150 Amperes and for the circuit breaker servicing the DMS Structure provide a 50 Ampere Double Pole Breaker. Ensure equipment cabinet disconnects are listed as meeting UL Standard UL-489 and marked as being suitable for use as service disconnects.

U-4405

TS-66

Cumberland County

For the DMS, furnish 4-wire stranded copper #8 AWG feeder conductors with THWN rating for supplying power to the DMS equipment cabinet. Provide conductor with the following:

- Listed as meeting UL Standard UL-83
- Meets ASTM B-3 and B-8 or B-787 standards.

Furnish 1" rigid galvanized conduit between the Service Disconnect and the collocated junction box. Transition to 2" HDPE conduit between junction boxes where the conduit will be installed under the roadway to a 2<sup>nd</sup> junction box. The the 2<sup>nd</sup> junction box transition back to 1" rigid galvanized conduit to the Supplemental Equipment Cabinet Disconnect.

Provide a grounding electrode system at all new electrical services. Provide underground marker tape above ground grounding electrodes and buried ground wire. Provide all grounding electrodes and ground wire necessary to ensure that grounding system, whether existing or new, complies with all grounding requirements of these Project Special Provisions.

### **B. Supplemental Equipment Cabinet Disconnect**

Furnish a Supplemental Equipment Cabinet Disconnect for the DMS installation since the service and cabinet are separated by a roadway. Furnish a Supplemental Equipment Cabinet Disconnect that will accommodate a minimum of 8 breakers in a lockable NEMA 3R enclosure. Fabricate enclosure from galvanized steel and electrostatically apply dry powder paint finish, light gray in color, to yield a minimum thickness of 2.4 mils. All exterior surfaces must be powder coated steel. Provide ground bus and neutral bus with a minimum of four terminals and a minimum wire capacity range of number 8 through number 2 AWG.

Install a 50 Ampere Double Pole circuit breaker rated for the calculated Arc-Fault Current. Mount the Supplemental Equipment Cabinet Disconnect on the pedestal close to the equipment cabinet. Ensure equipment cabinet disconnects are listed as meeting UL Standard UL-489 and marked as being suitable for use as service disconnects.

### **C. Grounding Electrodes (Ground Rods)**

Furnish 5/8"x10' copper clad steel grounding electrodes (ground rods), #4 AWG solid bare copper conductors, to make the grounding system installations. Secure the Copper conductor to the ground rod using an irreversible compression coupling using a ratcheting compression tool. Comply with the NEC, the *Standard Specifications*, these Project Special Provisions, and the Plans.

## **9.3. CONSTRUCTION METHODS**

### **A. General**

All work involving electrical service shall be coordinated with the appropriate electric utility company. Coordinate with the utility company to ascertain the feasibility of installing electrical service at each location before performing any work. Obtain all required local permits before beginning work.

Run feeder conductors separately from all other conductors in a 1-inch rigid galvanized conduit. Do not allow feeder conductors to share conduits with any other conductors or cables. Do not route unfused electrical feeder conductors inside of metal poles. Permanently label conductors at all access points using nylon tags labeled with permanent ink. Ensure each conductor has a unique identifier. Label conductors immediately upon installation. Use component name and labeling scheme approved by the Engineer.

U-4405

TS-67

Cumberland County

Use rigid galvanized conduit for all underground conduit runs 10 feet or less in length. For underground runs greater than 10 feet in length, the Contractor may transition from 1" rigid galvanized conduit to 2" HDPE conduit for the remainder of the run.

Direct bury pedestals that support combination panel at a minimum embedment depth of 24 inches below grade.

Upon completion of electrical service installation and backfilling of all excavations, restore the disturbed ground to its original condition as determined and approved by the Engineer. For paved areas, replace removed or damaged pavement with in kind materials, matching the elevation, color, texture/finish, and general appearance of the surrounding pavement in accordance with the "Equipment Cabinet Foundation" section of these Project Special Provisions. For unpaved areas, backfill excavations with removed material, tamp the backfilled material and rake smooth the top 1½ inches. Finish unpaved areas flush with surrounding natural ground and to match the original contour of the ground. Seed with same type of grass as surrounding area and mulch the newly seeded area. If unpaved area was not grassed, replace the original ground cover in kind as directed by the Engineer.

**Complete repairs to and restoration of all ground (paved and unpaved) disturbed for construction within five consecutive calendar days following initial removal.** If the Contractor fails to repair and restore the ground in accordance with these Project Special Provisions within the time frame specified, the Department reserves the right to make the necessary repairs, and all expenses incurred by the Department in making the repairs and restoring the ground will be deducted from payment due the Contractor.

Install meter socket covers on new meter bases to block access to the wiring inside until the meter is attached to the meter base by the power company. Use only approved meter socket covers that comply with these Project Special Provisions; do not use cardboard, paper, plywood, sheet plastic, tape, etc. to cover the meter socket opening. Do not leave a meter socket uncovered.

Provide all necessary stainless-steel banding hardware and clamps for securely attaching service disconnects, meter bases, combination panels and service conduits and risers to metal poles.

## **B. New Electrical Service for DMS**

At locations identified in the Plans, install new electrical service for the DMS cabinet in accordance with the details shown in the Plans. Install a new electrical service comprised of an external service disconnect and a meter base with meter socket cover housed in a combination panel. After installation of the meter base with meter socket cover, the local power company will remove the socket cover and install a new meter and make any necessary connections to the power lines.

Unless the Plans indicate otherwise, have the power company route the service drop underground to combination panel, even where source power lines are overhead.

## **C. Grounding of Electrical Services**

In addition to NEC requirements, test grounding electrode resistance for a maximum of 20 ohms. Furnish and install additional ground rods to grounding electrode system as necessary to meet test requirements. Furnish 5/8" x 10' copper clad steel grounding electrode system (ground rods), #4 AWG solid bare copper conductors, and an irreversible compression coupling for grounding system installations. Comply with NEC, the *Standard Specifications*, these Project Special Provisions, and the Plans.

U-4405

TS-68

Cumberland County

Follow test equipment's procedures for measuring grounding electrode resistance. When using clamp-type ground resistance meters, readings of less than 1 ohm typically indicate a ground loop. Rework bonding and grounding circuits as necessary to remove ground loop circuits and retest. If a ground loop cannot be identified and removed to allow the proper use of a clamp-type ground resistance meter, use the three-point test method.

Submit a completed Inductive Loop & Grounding Test Form available on the Department's website at:

<https://connect.ncdot.gov/resources/safety/Pages/ITS-and-Signals.aspx>

Install a length of marker tape 6 to 12 inches below finished grade directly over grounding electrodes and conductors.

#### **9.4. MEASUREMENT AND PAYMENT**

*DMS Electrical Service* will be measured and paid for as the actual number of complete, functional DMS electrical service locations furnished, installed, and tested.

No measurement will be made of risers with weatherheads as they will be considered incidental to furnishing and installing a new DMS electrical service.

No measurement will be made of short risers (i.e., from disconnect to underground conduit and from underground conduit to bottom of cabinet), meter bases, meter socket covers, service disconnects, additional circuit breakers in new service disconnects, underground conduit between service risers and disconnects/meters, conduit for feeder conductors between the service disconnect and the equipment cabinet, acquisition of service fees, feeder conductors, ground wire, grounding electrodes rods and any remaining hardware and conduit to connect the electrical service to the equipment cabinet as they will be considered incidental to furnishing and installing new electrical service.

No measurement will be made of restoration of unpaved ground surfaces with like materials, including but not limited to backfill, graded stone, seeding and mulching, as this work will be considered incidental to installation of a new electrical service.

Payment will be made under:

<b>Pay Item</b>	<b>Pay Unit</b>
DMS Electrical Service	Each

## **10. DIGITAL CCTV FIELD EQUIPMENT**

### **10.1. DESCRIPTION**

Furnish and install High Definition (1080p) CCTV field equipment described in these Project Special Provisions. Furnish equipment that is compatible, interoperable, and completely interchangeable with existing equipment currently in use by the Division. Ensure that the equipment is fully compatible with all features of the existing video management software currently in use by the Division.

10.2. MATERIAL

A. General

Furnish and install a new CCTV camera assembly at the location shown on the Plans. This assembly consists of the following:

- 1. Dome CCTV camera that contains in a single enclosed unit the following:

CCTV color digital signal processing camera unit with zoom lens, filter, control circuit, and accessories

- 2. Motorized pan, tilt, and zoom

All necessary cable, connectors, and incidental hardware to make a complete and operable system

Built-in video encoder capable of H.264/MPEG-4 compression for video-over-IP transmission.

Lightning arrestors installed in-line between the CCTV camera and the equipment cabinet components.

A NEMA Type 4 enclosure constructed of aluminum with a clear acrylic dome or approved equal Camera Unit housing.

B. Camera and Lens

*Cameras*

Furnish new Complementary Metal-Oxide-Semiconductor (CMOS) sensor-equipped color cameras. Furnish cameras that meet the following minimum requirements:

- Video format:.....NTSC compatible resolution, user selectable up to a maximum of 1920x1080 (1080p),
- Focus:.....Automatic with manual override, Electronic Image Stabilization (EIS),
- White balance:.....Automatic through the lens with manual override,
- Shutter:.....Electronic shutter with manual control from 1/2 of a second to 1/30,000th of a second,
- Overexposure protection:.....The camera must have built-in circuitry or a protection device to prevent any damage to the camera when pointed at strong light sources, including the sun,
- Sensitivity:.....0.6 lux at 90% scene reflectance
- Input/Output Connection:.....Single 10BASE-T/100BASE-T compatible outdoor-rated Cat5e cable for video, control, and Power

over Ethernet; IP66-rated RJ45 connector,

Power:.....High Power over Ethernet (High PoE), 74W max

**Zoom Lens**

Furnish each camera with a motorized zoom lens that is integrated in a high-performance dome system, or approved equivalent, with automatic iris control and manual override. Furnish lenses that meet the following optical specifications:

- Aperture .....f/1.6 – f/2.9,
- Focal length:.....4.45 mm (wide) and 89 mm (tele.), minimum,
- Horizontal viewing angle:.....55.4° (wide) and 2.9° (tele), minimum,
- Zoom.....30X optical, 12X digital, minimum
- Preset positioning:.....64 Presets, minimum.

The lens must be capable of both automatic and remote manual control iris and focus override operation. The lens must be equipped for remote control of zoom and focus, including automatic movement to any of the preset zoom and focus positions. Mechanical or electrical means must be provided to protect the motors from overrunning in extreme positions. The operating voltages of the lens must be compatible with the outputs of the camera control.

**C. Camera Housing**

Furnish new dome style enclosure for the CCTV assemblies. The enclosures must be equipped with a sunshield and a strip heater, and be fabricated from corrosion resistant aluminum and finished in a neutral color of weather resistant enamel. The enclosure must meet or exceed NEMA 4X and IP66 ratings. The viewing area of the enclosure must be constructed of clear acrylic, polycarbonate, or an approved equivalent.

Furnish removable dome enclosures that are secured to the camera housing using stainless steel set screws. Ensure that camera housing assembly is completely sealed with a rubber O-ring gasket to prevent dust and moisture intrusion.

Environmental Operating Conditions: -50°F to 122°F, 10-100% RH (condensing) humidity

**D. Pan and Tilt Unit**

Equip each new dome style assembly with a pan and tilt unit. The pan and tilt unit must be integral to the high performance integrated dome system. The pan and tilt unit must be rated for outdoor operation, provide dynamic braking for instantaneous stopping, prevent drift, and have minimum backlash. The pan and tilt units must meet or exceed the following specifications:

- Pan:.....Continuous 360 Degrees,
- Tilt:.....Up/down 180 degrees minimum,

**U-4405****TS-71****Cumberland County**

Motors:.....Two-phase induction type,  
continuous duty, instantaneous  
reversing,

Preset Positioning:.....64 PTZ presets per camera.

**E. Video Ethernet Encoder**

Furnish cameras with a built-in digital video Ethernet encoder to allow video-over-IP transmission. The encoder units must be built into the camera housing and require no additional equipment to transmit encoded video over IP networks.

Encoders must have the following minimum features:

- Network Interface: Ethernet 10/100Base-T (RJ-45 connector)
- Protocols: IPv4, IPv6, HTTP, HTTPS, SSL, QoS, FTP, SMTP, UPnP, SNMP v2c/v3, DNS, NTP, RTSP, RTP, TCP, UDP, IGMP, and DHCP,
- Security: SSL, SSH, 802.1x, HTTPS encryption with password controlled browser interface
- Video Streams: 2 simultaneous streams, user configurable
- Compression: H.264 (MPEG-4 Part 10/AVC)
- Resolution Scalable; NTSC-compatible 320x176 to 1920x1080 (HDTV 1080p, 16:9 aspect ratio)
- Frame Rate: 1-30 FPS programmable (full motion)
- Bandwidth 30 kbps – 6 Mbps, configurable depending on resolution
- Edge Storage: SD/SDHC/SDXC slot supporting up to 64GB memory card

**F. Ethernet Cable**

Provide, at a minimum, Category 5 Enhanced (5e) Ethernet cable that complies with ANSI/TIA-568-B-5 standards for four-pair shielded twisted copper for Ethernet communications. The cable shall meet all of the mechanical requirements of ANSI/ECEA S-80-576. The Ethernet cable must be rated for medium-power, network-powered broadband communications circuits and must be Type BMU network-powered broadband communications medium-power cable.

Provide 4-pair twisted copper Ethernet cable and connectors rated for an ambient operating temperature range of -30° F to 165° F. The cable shall be shielded, outdoor-rated, and have a UV-resistant jacket. The void between the insulated copper pairs and the polyethylene outer jacket shall be injected with a water-resistant flooding compound.

**G. Control Receiver/Driver**

Provide each new camera unit with a control receiver/driver that is integral to the CCTV dome assembly. The control receiver/driver will receive serial asynchronous data initiated from a camera control unit, decode the command data, perform error checking, and drive the pan/tilt unit, camera controls, and motorized lens. As a minimum, the control receiver/drivers must provide the following functions:

- Zoom in/out

- Automatic focus with manual override
- Tilt up/down
- Automatic iris with manual override
- Pan right/left
- Minimum 64 preset positions for pan, tilt, and zoom

In addition, each control receiver/driver must accept status information from the pan/tilt unit and motorized lens for preset positioning of those components. The control receiver/driver will relay pan, tilt, zoom, and focus positions from the field to the remote camera control unit. The control receiver/driver must accept “goto” preset commands from the camera control unit, decode the command data, perform error checking, and drive the pan/tilt and motorized zoom lens to the correct preset position. The preset commands from the camera control unit will consist of unique values for the desired pan, tilt, zoom, and focus positions.

#### **H. CCTV Camera Attachment to Pole**

At locations shown in the Plans where new CCTV cameras are to be installed on a new pole, furnish an attachment assembly for the CCTV camera unit. Submit shop drawings for review and approval by the Engineer prior to installation.

Furnish CCTV attachments that allow for the removal and replacement of the CCTV enclosure as well as providing a weatherproof, weather tight, seal that does not allow moisture to enter the enclosure.

Furnish a CCTV Camera Attachment Assembly that is able to withstand wind loading at the maximum wind speed and gust factor called for in these Special Provisions and can support a minimum camera unit dead load of 45 pounds (20.4 kg).

#### **I. Surge Suppression**

Protect all equipment at the top of the pole with grounded metal oxide varistors connecting each power conductor to ground.

### **10.3. CONSTRUCTION METHOD**

#### **A. General**

Mount the digital CCTV camera unit at 35 feet above ground level on the new CCTV metal poles (40'). Position the camera to enable viewing traffic in all directions and as approved by the Engineer.

Mount the CCTV camera unit such that a minimum 5 feet of clearance is maintained between the camera and the top of the pole.

Mount CCTV camera on the side of pole nearest intended field of view. Avoid occluding the view with the pole.

#### **B. Electrical and Mechanical Requirements**

Install Power over Ethernet (PoE) injector in existing equipment cabinet, and run an outdoor-rated Cat5e Ethernet cable through the existing conduit and up the pole to the CCTV assembly as shown in the Signal Communications Plans. Take all precautions necessary to ensure the Ethernet cable is not damaged during storage and installation. Do not step on the cable nor run over the cable



with vehicles or equipment. Do not pull the cable over or around obstructions or along the ground. Install the cables according to the latest version of the manufacturer’s cable installation procedures and the industry-accepted installation standards, codes, and practices, or as directed by the Engineer.

Ground all equipment as called for in the Standard Specifications, these Special Provisions, and the Plans.

Install surge protectors on all ungrounded conductors entering the CCTV enclosure. House the protectors in a small, ventilated weatherproof cabinet attached near the CCTV attachment point in a manner approved by the Engineer.

Furnish all tools, equipment, materials, supplies, and hardware necessary to install a fully operational CCTV camera system as depicted in the plans.

**10.4. MEASUREMENT AND PAYMENT**

*Digital CCTV Camera Assembly* will be measured and paid as the actual number of Digital CCTV Camera Assemblies furnished, installed, integrated, and accepted. No separate measurement will be made for necessary cabling, PoE cable, connectors, CCTV camera attachment assemblies, conduit, condulets, grounding equipment, surge protectors, CCTV control software, or any other equipment or labor required to install the CCTV assembly.

Payment will be made under:

Digital CCTV Camera Assembly ..... Each

**11. CCTV METAL POLES**

**11.1. CCTV METAL POLES**

**A. General:**

Furnish and install a new 40’ tapered CCTV metal pole, grounding system, and all necessary hardware. The work covered by this special provision includes requirements for the design, fabrication, and installation of custom designed CCTV metal poles and associated foundations.

Comply with applicable sections of the *2018 STANDARD SPECIFICATIONS FOR ROADS & STRUCTURES*, hereinafter referred to as the *Standard Specifications*. Provide designs of completed assemblies with hardware that equals or exceeds *AASHTO Standard Specifications for Structural Supports for Highway Signs, Luminaires, and Traffic Signals* 6th Edition, 2013 (hereafter called AASHTO), including the latest interim specifications. Provide assemblies with a round or near-round (18 sides or more) cross-section, or a multi sided cross section with no less than six sides. The sides may be straight, convex, or concave.

After fabrication, hot-dip galvanize steel poles, and all parts used in the assembly in accordance with section 1076 of the *Standard Specification*. Design structural assemblies with weep holes large enough and properly located to drain molten zinc during galvanization process. Galvanize structures to meet or exceed AASHTO M 111. Provide galvanizing on hardware that meets or exceeds ASTM Standard A-153. Ensure that threaded material is brushed and re-tapped as necessary after galvanizing. Perform repair of damaged galvanizing that complies with the following:

Repair of Galvanizing .....Article 1076-6

U-4405

TS-74

Cumberland County

Standard Drawings for Metal Poles are available that supplement these project special provisions. These drawings are located on the Department's website:

<https://connect.ncdot.gov/resources/safety/Pages/ITS-Design-Resources.aspx>

Comply with article 1098-1B "General Requirements" of the *Standard Specifications* for submittal requirements. Furnish shop drawings for approval. Provide the copies of detailed shop drawings for each type of structure as summarized below. Ensure that shop drawings include material specifications for each component and identify welds by type and size on the drawing details, not in table format. Do not release structures for fabrication until shop drawings have been approved by NCDOT. Provide an itemized bill of materials for all structural components and associated connecting hardware on the drawings.

Comply with article 1098-1A "General Requirements" of the *Standard Specifications* for Qualified Products List (QPL) submittals. All shop drawings must include project location description, CCTV Asset inventory number(s), and a project number or work order number on the drawings.

**Mark final pole locations and receive approval from the Engineer before initiating bore samples and designing foundations.**

Summary of information required for metal pole review submittal:

Item	Hardcopy Submittal	Electronic Submittal	Comments / Special Instructions
Sealed, Approved ITS Plan/Loading Diagram	1	1	All structure design information needs to reflect the latest approved ITS plans
Custom Pole Shop Drawings	4 sets	1 set	Submit drawings on 11" x 17" format media Show NCDOT inventory number(s) in or above the title block
Structure Calculations	1 set	1 set	
Custom Foundation Drawings	4 sets	1 set	Submit drawings on 11" x 17" format media.
Foundation Calculations	1	1	Submit L Pile calculations per Section 11.4 of this Project Special Provision.
Soil Boring Logs and Report	1	1	Report should include a location plan and a soil classification report including soil capacity, water level, hammer efficiency, soil bearing pressure, soil density, etc. for each pole.

**NOTE** – All shop drawings and custom foundation design drawings must be sealed by a professional Engineer licensed in the state of North Carolina. All geotechnical information must be sealed by either a Professional Engineer or geologist licensed in the state of North Carolina. Include a title block and revision block on the shop drawings and foundation designs showing the NCDOT inventory number.

Shop drawings and foundation drawings may be submitted together or separately for approval. However, shop drawings must be approved before foundations can be reviewed. Foundation designs

will be returned without review if the associated shop drawing has not been approved. Incomplete submittals will be returned without review.

### 11.2. MATERIALS:

Fabricate CCTV metal pole from coil or plate steel to meet the requirements of ASTM A 595 Grade A tubes. For structural steel shapes, plates and bars use A572 Gr 50 min or ASTM A709 Gr 50 min. Provide poles that are round in cross section or multisided tubular shapes and have a uniform linear taper of 0.14 in/ft. Construct shafts from one piece of single ply plate or coil so there are no circumferential weld splices. Galvanize in accordance with AASHTO M 111 and/or ASTM A 123 or an approved equivalent.

Ensure that allowable pole deflection does not exceed that allowed per 6<sup>th</sup> Edition AASHTO. Ensure that maximum deflection at the top of the pole does not exceed 2.0 percent of the pole height.

Use the submerged arc process or other NCDOT previously approved process suitable for poles to continuously weld pole shafts along their entire length. The longitudinal seam weld will be finished flush to the outside contour of the base metal. Ensure shafts have no circumferential welds except at the lower end joining the shaft to the pole base. In the event that a circumferential weld is necessary, prior approval is required from the Engineer and NCDOT Materials and Test Unit. Provide welding that conforms to Article 1072-20 of the *Standard Specifications*, except that no field welding on any part of the pole will be permitted unless approved by a qualified engineer.

Refer to Metal Pole Standard Drawing Sheets M2 through M5 for fabrication details. Fabricate anchor bases from plate steel meeting, as a minimum, the requirements of ASTM A 36M or cast steel meeting the requirements of ASTM A 27M Grade 485-250, AASHTO M270 Gr 36 or an approved equivalent. Conform to the applicable bolt pattern and orientation as shown on Metal Pole Standard Drawing Sheet M2.

Ensure all hardware is galvanized steel or stainless steel. The Contractor is responsible for ensuring that the designer/fabricator specifies connecting hardware and/or materials that do not create a dissimilar metal corrosive reaction.

Unless otherwise required by the design, ensure each anchor rod is 2" diameter and 60" length. Provide 10" minimum thread projection at the top of the rod, and 8" minimum at the bottom of the rod. Use anchor rod assembly and drilled pier foundation materials that meet the *Foundations and Anchor Rod Assemblies for Metal Poles* provision.

For each structural bolt and other steel hardware, hot dip galvanizing shall conform to the requirements of AASHTO M 232 (ASTM A 153). Ensure end caps for poles are constructed of cast aluminum conforming to Aluminum Alloy 356.0F.

Provide a circular anchor bolt lock plate that will be secured to the anchor bolts at the embedded end with 2 washers and 2 nuts. Provide a base plate template that matches the bolt circle diameter of the anchor bolt lock plate. Construct plates and templates from 1/4" minimum thick steel with a minimum width of 4". Galvanizing is not required.

Provide 4 heavy hex nuts and 4 flat washers for each anchor bolt. For nuts, use AASHTO M291 grade 2H, DH, or DH3 or equivalent material. For flat washers, use AASHTO M293 or equivalent material.

Provide a 2-inch hole equipped with an associated coupling and weatherhead approximately 5 feet below the top of the pole to accommodate passage of CCTV cables from inside the pole to the CCTV camera.

Provide a 2-inch hole equipped with an associated coupling and conduit fittings/bodies approximately 18 inches above the base of the pole accommodate passage of CCTV cables from the CCTV cabinet to the inside of the pole. Refer to Metal Pole Standard Drawing Sheet M3 for fabrication details.

Have poles permanently stamped above the base hand hole with the identification tag details as shown on Metal Pole Standard Drawing Sheet M2.

For each pole, provide a 1/2-inch minimum thread diameter, coarse thread stud and nut for grounding which will accommodate #4 AWG ground wire. Ensure that the lug is electrically bonded to the pole and is conveniently located inside the pole at the hand hole.

Provide a removable pole cap with stainless steel attachment screws for the top of each pole. Ensure that the cap is cast aluminum conforming to Aluminum Association Alloy 356.0F. Furnish cap attached to the pole with a sturdy chain or cable approved by the Engineer. Ensure that the chain or cable is long enough to permit the cap to hang clear of the pole-top opening when the cap is removed.

### 11.3. CONSTRUCTION METHODS:

Install anchor rod assemblies in accordance with the *Foundations and Anchor Rod Assemblies for Metal Poles* provision (SP09-R005) located on the Department's 2018 Standard Specifications and Provisions website:

<https://connect.ncdot.gov/resources/Specifications/Pages/Specifications-and-Special-Provisions.aspx>

Erect CCTV metal poles only after concrete has attained a minimum allowable compressive strength of 3000 psi. Final approval of foundation is contingent upon concrete achieving a compressive strength of 4,500 psi strength as required by *Foundations and Anchor Rod Assemblies for Metal Poles* provision. Connect poles to grounding electrodes and bond them to the electrical service grounding electrodes.

For holes in the poles used to accommodate cables, install grommets before wiring pole or arm. Do not cut or split grommets.

Attach the hand hole covers to the pole by a sturdy chain or cable. Ensure the chain or cable is long enough to permit the cover to hang clear of the opening when the cover is removed, and is strong enough to prevent vandalism. Ensure the chain or cable will not interfere with service to the cables in the pole.

Attach cap to pole with a sturdy chain or cable. Ensure the chain or cable is long enough to permit the cap to hang clear of the opening when the cap is removed.

Perform repair of damaged galvanizing that complies with the *Standard Specifications*, Article 1076-7 "Repair of Galvanizing."

Install galvanized wire mesh around the perimeter of the base plate to cover the gap between the base plate and top of foundation for debris and pest control.

Install a 1/4" thick plate for concrete foundation tag to include: concrete grade, depth, diameter, and reinforcement sizes of the installed foundation.

Install CCTV metal poles, hardware, and fittings as shown on the manufacturer's installation drawings. Install poles so that when the pole is fully loaded it is within .5 degrees of vertical.

#### **11.4. DRILLED PIER FOUNDATIONS FOR METAL POLES**

Analysis procedures and formulas shall be based on AASHTO, ACI code and per FHWA Manuals. Design methods based on engineering publications or research papers needs to have prior approval from NCDOT. The Department reserves the right to accept or disapprove any method used for the analysis.

Use a Factor of Safety of 1.33 for torsion and 2.0 for bending for the foundation design.

Foundation design for lateral load shall not exceed 1" lateral deflection at top of foundation.

Design all custom foundations to carry the maximum capacity of each metal pole.

When poor soil conditions are encountered which could create an excessively large foundation design, consideration may be given to allowing an exemption to the maximum capacity design. The contractor must gain approval from the engineer before reducing a foundation's capacity. On projects where poor soil is known to be present, it is advisable that the contractor gain foundation approval before releasing poles for fabrication.

##### **A. Description:**

Design, furnish and install foundations for CCTV metal poles with all necessary hardware in accordance with the plans and specifications.

Design all CCTV pole foundations using actual soil conditions at each pole location. Perform soil test in accordance with article "B" Soil Test and Foundation Determination of this special provision.

##### **B. Soil Test and Foundation Determination:**

Drilled piers are reinforced concrete sections, cast-in-place against in situ, undisturbed soil. Drilled piers are of straight shaft type and vertical.

Some drilled piers for supporting metal poles may require wing walls to resist torsional rotation. Based upon this provision and the results of the required soil test, a drilled pier length requirement may be determined and constructed in accordance with the plans.

Soil Test:

Perform a soil test at each proposed metal pole location. Complete all required fill placement and excavation at each signal pole location to finished grade before drilling each boring. Soil tests performed that are not in compliance with this requirement may be rejected and will not be paid. Drill one boring to a depth of 26 feet within a 25-foot radius of each proposed foundation.

Perform standard penetration tests (SPT) in accordance with ASTM D 1586 at depths of 1, 2.5, 5, 7.5, 10, 15, 20 and 26 feet. Discontinue the boring if one of the following occurs:

- A total of 100 blows have been applied in any 2 consecutive 6-in. intervals.
- A total of 50 blows have been applied with < 3-in. penetration.

Describe each CCTV pole location along the project corridor in a manner that is easily discernible to both the contractor's designer and NCDOT reviewers. If a CCTV pole is at an intersection, label the boring the "Intersection of (Route or SR #), (Street Name) and (Route or SR #),"

U-4405

TS-78

Cumberland County

(Street Name), \_\_\_\_\_ County, Signal Inventory No. \_\_\_\_\_”. Label borings with “B- N, S, E, W, NE, NW, SE or SW” corresponding to the quadrant location within the intersection.

If the CCTV pole location is located between intersections, provide a coordinate location and offset, or milepost number and offset. Pole numbers should be made available to the geotechnical drilling Contractor. Include pole numbers in the boring label if they are available. If they are not available, ensure the boring labels can be cross-referenced to corresponding pole numbers or pole locations. For each boring, submit a legible (hand written or typed) boring log signed and sealed by a licensed Geologist or Professional Engineer registered in North Carolina. Include on each boring the SPT blow counts and N-values at each depth, depth of the boring, and a general description of the soil types encountered.

Borings that can't be easily related to their specific pole location will be returned to the contractor for clarification, or if approved by the engineer, the foundation may be designed using the worst-case soil condition obtained as part of this project.

i. Standard Foundation Determination:

Use the following method for determining the Design N-value:

$$N_{AVG} = \frac{(N@1' + N@2.5' + \dots + N@Deepest \text{ Boring Depth})}{\text{Total Number of N-values}}$$

$$Y = (N@1')^2 + (N@2.5')^2 + \dots + (N@Deepest \text{ Boring Depth})^2$$

$$Z = (N@1' + N@2.5' + \dots + N@Deepest \text{ Boring Depth})$$

$$N_{STD \text{ DEV}} = \left[ \frac{(\text{Total Number of N-values} \times Y) - Z^2}{(\text{Total Number of N-values}) \times (\text{Total Number of N-values} - 1)} \right]^{0.5}$$

**Design N-value** equals lesser of the following two conditions:

$$N_{AVG} - (N_{STD \text{ DEV}} \times 0.45)$$

Or

$$\text{Average of First Four N-Values} = \frac{(N@1' + N@2.5' + N@5' + N@7.5')}{4}$$

*Note: If less than 4 N-values are obtained because of criteria listed in Section 2 above, use average of N-values collected for second condition. Do not include the N-value at the deepest boring depth for above calculations if the boring is discontinued at or before the required boring depth because of criteria listed in Section 2 above. Use N-value of zero for weight of hammer or weight of rod. If N-value is greater than 50, reduce N-value to 50 for calculations.*

Submit completed boring logs collected in accordance with Section 2 (Soil Test) above along with pole loading diagrams from the plans to the contractor-selected pole fabricator to assist in the pole and foundation design.

If one of the following occurs, contact the Engineer.

- The Design N-value is less than 4.
- The drilled pier length, “L”, is greater than the depth of the corresponding boring.

Foundation designs are based on level ground around the traffic signal pole. If the slope around the edge of the drilled pier is steeper than 8:1 (H:V) or the proposed foundation will be less than 10 feet from the top of an embankment slope, the Contractor is responsible for providing slope information to the foundation designer and to the Engineer, so it can be considered in the design.

If assistance is needed, contact the Engineer.

**C. Non-Standard Foundation Design:**

Design non-standard foundations based upon site-specific soil test information collected in accordance with Section 2 (Soil Test) above. Design drilled piers for side resistance only in accordance with Section 4.6 of the *AASHTO Standard Specifications for Highway Bridges*. Use the computer software LPILE version 5.0 or later manufactured by Ensoft, Inc. to analyze drilled piers. Use the computer software gINT version 8.0 or later manufactured by Bentley Systems, Inc. with the current NCDOT gINT library and data template to produce SPT boring logs. Provide a drilled pier foundation for each pole with a length and diameter that result in a horizontal lateral movement of less than 1 inch at the top of the pier and a horizontal rotational movement of less than 1 inch at the edge of the pier. Submit and gain approval of foundation designs including drawings, calculations, and soil boring before construction. Foundations installed without prior approval may be rejected.

**D. Drilled Pier Construction:**

Construct drilled pier foundations in accordance with the *Foundations and Anchor Rod Assemblies for Metal Poles* provision (SP09 R005). This provision may be located at:

<https://connect.ncdot.gov/resources/Specifications/Pages/Specifications-and-Special-Provisions.aspx>

**11.5. MEASUREMENT AND PAYMENT**

Actual number of CCTV Metal Poles (40') furnished, installed and accepted.

Actual number of Soil Tests with SPT borings performed furnished and accepted.

Actual volume of concrete poured in cubic yards of Drilled Pier Foundation furnished, installed, and accepted.

No measurement will be made for CCTV Metal Pole designs and foundation designs, as these will be considered incidental to CCTV Metal Poles and Drilled Pier Foundations.

Payment will be made under:

CCTV Metal Pole (40').....	Each
Soil Test for CCTV Pole.....	Each
Drilled Pier Foundation for CCTV Pole .....	Cubic Yards

**12. DYNAMIC MESSAGE SIGN (DMS)**

**12.1. DESCRIPTION**

For this project furnish two (2) DMS's mounted back to back on a single support structure.

DMSs used on the State Highway System shall be preapproved on the current NCDOT ITS & Signals 2012 Qualified Products List (QPL) by the date of installation. DMSs not reapproved will not be allowed for use on the project. To ensure compatibility with the existing DMS Control Software deployed in the State, furnish NTCIP compliant DMSs that are fully compatible with

Daktronics, Inc. Vanguard Version 4 software (also referred to hereinafter as the “Control Software”). The QPL is available on the Department’s website. The QPL website is:

**<https://connect.ncdot.gov/resources/safety/Pages/ITS-and-Signals-Qualified-Products.aspx>**

Furnish and install DMSs compliant with UL standards 48, 50, and 879.

Add and configure the new DMSs in the system using the Control Software and computer system. Furnish, install, test, integrate and make fully operational the new DMSs at locations shown in the plans.

Contact the Engineer to confirm all DMS locations prior to beginning construction. Furnish operating DMS systems consisting of, but not limited to, the following:

- Full Matrix, 27 pixel high and 90 pixels wide LED DMS with 18” border
- DMS mounting hardware
- DMS controllers, Uninterruptible Power Supplies (UPS), cabinets and accessories with interconnect and power cabling and conduit
- Branch circuit conductors and related equipment
- All other equipment and incidentals required for furnishing, installing, and testing the DMS system and system components

Use only UL listed and approved electronic and electrical components in the DMS system.

## **12.2. MATERIALS**

### **A. Environmental Requirements**

Construct the DMS and DMS controller-cabinet so the equipment within shall be protected against moisture, dust, corrosion, and vandalism.

Design the DMS system to comply with the requirements of Section 2.1 (Environmental and Operating Standards) of NEMA TS 4-2005.

### **B. Full Matrix Led Dynamic Message Sign (DMS)**

Construct the DMS to display at least three lines of text that, when installed, are clearly visible and legible to a person with 20 / 20 corrected vision from a distance of 900 feet in advance of the DMS at an eye height of 3.5 feet along the axis.

When displaying three lines, each line must display at least 15 equally spaced and equally sized alphanumeric individual characters. Each character must be at least 18 inches in height and composed from a luminous dot matrix. The entire LED matrix shall be at the minimum 27 pixels high and 90 pixels wide.

#### **1. DMS Enclosure**

Comply with the requirements of Section 3 (Sign Mechanical Construction) of NEMA TS 4-2005 as it applies to Walk-in enclosures. The following requirements complement TS 4-2005:

- Construct the DMS with a metal front-access enclosure excluding the face. Provide an aluminum walking platform inside the enclosure that is at least 28 inches wide. Ensure the width of the walking platform is free of obstructions to a height of 7 feet. Construct the enclosure of welded aluminum type 6061-T6, 5052-H38, 5052-H34, or of an Engineer approved alternate at least 1/8-inch thick. Perform all welding of aluminum and aluminum alloys in accordance with the latest edition of AWS D1.2, Structural Welding



Code - Aluminum. Continuously weld the seams using Gas Metal Arc Welding (GMAW).

- Provide all exterior and interior DMS enclosure surfaces with natural, mill-finish aluminum. Remove all grind marks and discoloration from the surfaces.
- Provide corrosion resistant nuts, bolts, washers, and other mounting and bonding parts and components used on the exterior of the DMS enclosure and ensure they are sealed against water intrusion.
- Provide one access door for each 10 to 15 pixel wide section of the sign enclosure. Vertically hinge the doors and design to swing out from the face to provide access to the enclosure interior. Extend each door the full height of the display matrix.
- Provide a retaining latch mechanism for each door to hold the door open at a 90-degree angle.
- Each door will form the face panel for a section of the sign. Mount the LED modules to the door such that they can be removed from the door when in the open position. Other sign components can be located inside the sign enclosure and be accessible through the door opening.
- Provide for each door a minimum of two (2) screw-type captive latches to lock them in the closed position and pull the door tight and compress a gasket located around the perimeter of each door. Install the gasket around the doors to prevent water from entering the cabinet.
- Do not place a manufacturer name, logo, or other information on the front face of the DMS or shield visible to the motorist.
- Provide power supply monitoring circuitry to detect power failure in the DMS and to automatically report this fault to the Control Software. This requirement shall be in addition to reporting power failure at the controller cabinet.
- Do not paint the stainless steel bolts on the Z-bar assembly used for mounting the enclosure.

## 2. DMS Interior Environment Control

Design the local field controller to monitor and control the interior DMS environment. Design environmental control to maintain the internal DMS temperature within +/- 10° F of the outdoor ambient temperature. Provide the DMS environmental control system with four primary subsystems as follows:

- a. **Internal Temperature Sensors** – Provide the DMS with two internally mounted temperature sensors that are equipped with external thermocouples and which the Field Controller continuously monitors. Design the Field Controller to use this temperature information to determine when to activate and deactivate the environmental control systems described herein. Locate sensors on opposite ends of the upper 1/3 of the LED display matrix with their external thermocouples attached to and making contact with an LED pixel circuit board. Design the thermocouple and LED board to be easily detachable, in the event that one of the units requires removal and replacement. Provide sensors capable of measuring temperatures from -40° F to +185° F. Design the Field Controller to automatically shut down

the LED display whenever one or both sensors indicates that LED board temperature has exceeded +140° F, and to automatically restart the LED display whenever the suspect temperature falls below +130° F. Design both shutdown and re-start temperature thresholds to be user-programmable. Design the field controller to report sensor temperatures and DMS shutdown/re-start events to the DMS Control Software.

**b. Housing Cooling System** – Provide the DMS housing with a cooling system that circulates outside air into the DMS housing whenever the LED board temperature exceeds a user-programmable threshold. Provide this system with enough ventilation fans to exchange the internal DMS housing air volume at a minimum rate of two times per minute. Provide steel ball bearing type fans. Mount fans in a line across the upper rear wall of the DMS housing to direct air out of the cabinet. Provide one filtered air intake port for each exhaust fan. Locate intake ports in a line across the lower rear wall of the DMS housing. Provide intake ports with a removable filter that will remove airborne particles measuring 500 microns in diameter and larger. Provide a filter that is of a size and style that is commercially readily available. Program the field controller to activate the DMS housing cooling system whenever the LED board temperature exceeds +90° F and to turn the cooling system off whenever LED board temperature falls below +85° F. On the DMS housing rear exterior wall, cover all air intake and exhaust ports on their top, front, and sides by an aluminum shroud fabricated from 0.090-inch aluminum sheeting. Taper the shrouds at the top. Securely fasten shrouds to the DMS housing, and provide gaskets at the interface to prevent water from entering the DMS. Design all air filters and fans to be removable from inside the DMS housing. Provide the DMS housing cooling system with an adjustable timer that will turn fans off after the set time has expired. Provide a timer that is adjustable to at least 4 hours, and locate it just inside the DMS housing door, within easy reach of a maintenance technician standing outside the DMS doorway.

**c. LED Display Cooling System** – Provide the DMS with an LED display cooling system which directs air across the LED display modules whenever LED board temperature exceeds a user-programmable threshold. Direct fan-forced air vertically across the backside of the entire LED display matrix using multiple ball-bearing fans. Program the field controller to activate the LED cooling fan system whenever LED board temperature exceeds +90° F and to deactivate the system whenever LED board temperature falls to +85° F. Locate cooling fans so as not to hinder removal of LED display modules and driver boards.

**d. Front Face Panel Defog / Defrost System** – Provide the DMS with a defog / defrost system which circulates warm, fan-forced air across the inside of the polycarbonate front face whenever LED board temperature falls below a user-programmable threshold. Provide multiple steel ball-bearing fans that provide uniform airflow across the face panel. Program the field controller to activate the defog / defrost system whenever LED board temperature falls below +40° F and to deactivate the defog / defrost system whenever LED board temperature exceeds +106° F. Mount a 100-watt pencil-style heating element in front of each defog / defrost fan to warm the air directed across the DMS face. Design heating elements to be on only when the defog / defrost fans are on.

Install additional fans and / or heaters as needed to maintain the temperature inside the DMS enclosure within the operating temperature range of the equipment within the DMS enclosure as recommended by the equipment manufacturer(s).

### 3. Front Panel

Protect the DMS face with contiguous, weather-tight, removable panels. These panels shall be a polycarbonate material that are ultraviolet protected, have an antireflection coating, and are a minimum of 1/8- inch thick.

Furnish polycarbonate panels with the following characteristics:

- Tensile Strength, Ultimate: 10,000 PSI
- Tensile Strength, Yield: 9,300 PSI
- Tensile Strain at Break: 125%
- Tensile Modulus: 330,000 PSI
- Flexural Modulus: 330,000 PSI
- Impact Strength, Izod (1/8", notched): 17 ft-lbs/inch of notch
- Rockwell Hardness: M75, R118
- Heat Deflection Temperature Under Load: 264 PSI at 270° F and 66 PSI at 288° F
- Coefficient of Thermal Expansion:  $3.9 \times 10^{-5}$  in/in/F
- Specific Heat: 0.30 BTU/lb/F
- Initial Light Transmittance: 85% minimum
- Change in Light Transmittance, 3 years exposure in a Southern latitude: 3%
- Change in Yellowness Index, 3 years exposure in a Southern latitude: less than 5%

For substitutes, submit one 12" x 12" sample of the proposed material together with a description of the material attributes to the Engineer for review and approval. Install a .09" aluminum mask on the front of the panel (facing the motorists) that contains a circular opening for each LED pixel. Prime and coat the front side of the aluminum mask, which faces the viewing motorists, with automotive-grade flat black acrylic enamel paint or an approved equivalent. Guarantee all painted surfaces provide a minimum outdoor service life of 20 years.

Design the panels so they will not warp nor reduce the legibility of the characters. Differential expansion of the DMS housing and the front panel must not cause damage to any DMS component or allow openings for moisture or dust. Glare from sunlight, roadway lighting, commercial lighting, or vehicle headlights must not reduce the legibility or visibility of the DMS. Install the panels so that a maintenance person can easily remove or open them for cleaning.

### 4. Display Modules

Manufacture each display module with a standard number of pixels, not to exceed an array of 9 x 5, which can be easily removed. Assemble the modules onto the DMS assemblies contiguously to form a continuous matrix to display the required number of lines, characters, and character height.

Design display modules that are interchangeable and replaceable without using special tools. Provide plug-in type power and communication cables to connect to a display module. Construct each display module as a rectangular array of 5 horizontal pixels by 7 to 9 vertical pixels. Provide

U-4405

TS-84

Cumberland County

the module with an equal vertical and horizontal pitch between pixels, and columns that are perpendicular to the rows (i.e., no slant).

Design each module to display:

- All upper and lower-case letters
- All punctuation marks
- All numerals 0 to 9
- Special user-created characters

Display upper-case letters and numerals over the complete height of the module. Optimize the LED grouping and mounting angle within a pixel for maximum readability.

**Furnish two (2) spare display modules per each DMS installed for emergency restoration.**

#### **5. Discrete LEDs**

Provide discrete LEDs with a nominal viewing cone of **30 degrees** with a half power angle of 15 degrees measured from the longitudinal axis of the LED. Viewing cone tolerances shall be as specified in the LED manufacturer's product specifications and shall not exceed +/- 3 degrees half-power viewing angle of 30 degrees.

Provide LEDs that are untinted, non-diffused, high output solid state lamps utilizing indium gallium aluminum phosphide (InGaAlP) technology. Provide T1 <sup>3</sup>/<sub>4</sub>, 0.2-inch size LEDs that emit a true amber color at a wavelength of 590 ± 5 nm.

Provide LEDs with a MTBF (Mean Time Before Failure) of at least 100,000 hours of permanent use at an operating point of 140° F or below at a specific forward current of 20mA. Discrete LED failure is defined as the point at which the LED's luminous intensity has degraded to 50% or less of its original level. Obtain the LEDs used in the display from a single LED manufacturer that have a single part number. Obtain them from batches sorted for luminous output, where the highest luminosity LED is not more than fifty percent more luminous than the lowest luminosity LED when the LEDs are driven at the same forward current. Do not use more than two successive and overlapping batches in the LED display. Document the procedure to be used to comply with this requirement as part of the material submittal.

Individually mount the LEDs on circuit boards that are at least 1/16" thick FR-4 fiberglass, flat black printed circuit board in a manner that promotes cooling. Protect all exposed metal on both sides of the LED pixel board (except the power connector) from water and humidity exposure by a thorough application of acrylic conformal coating. Design the boards so bench level repairs to individual pixels, including discrete LED replacement and conformal coating repair is possible.

Operate the LED display at a low internal DC voltage not to exceed 24 Volts.

Design the LED display operating range to be -20° F to +14° F at 95% relative humidity, non-condensing.

Supply the LED manufacturer's technical specification sheet with the material submittals.

## 6. LED Power Supplies

Power the LED Display by means of multiple regulated switching DC power supplies that operate from 120 volts AC input power and have an output of 48 volts DC or less. Wire the supplies in a redundant parallel configuration that uses multiple power supplies per display. Provide the supplies with current sharing capability that allows equal amounts of current to their portion of the LED display. Provide power supplies rated such that if one supply fails the remaining supplies will be able to operate their portion of the display under full load conditions (i.e. all pixels on at maximum brightness) and at a temperature of 140° F.

Provide power supplies to operate within a minimum input voltage range of +90 to +135 volts AC and within a temperature range of -22° F to 140° F. Power supply output at 140° F must not deteriorate to less than 65% of its specified output at 70° F. Provide power supplies that are overload protected by means of circuit breakers, that have an efficiency rating of at least 75%, a power factor rating of at least .95, and are UL listed. Provide all power supplies from the same manufacturer and with the same model number. Design the power driver circuitry to minimize power consumption.

Design the field controller to monitor the operational status (normal or failed) of each individual power supply and be able to display this information on the Client Computer screen.

## 7. LED Pixels

A pixel is defined as the smallest programmable portion of a display module that consists of a cluster of closely spaced discrete LEDs. Design each pixel to be a maximum of two inches in diameter.

Construct the pixels with two strings of LEDs. It is the manufacturer's responsibility to determine the number of LEDs in each string to produce the candela requirement as stated herein.

Ensure each pixel produces a luminous intensity of 40 Cd when driven with an LED drive current of 20 mA per string.

Power the LEDs in each pixel in strings. Use a redundant design so that the failure of an LED in one string does not affect the operation of any other string within the pixel. Provide the sign controller with the ability to detect the failure of any LED string and identify which LED string has failed. Submit a complete schematic of the LED power and driver circuits with the material submittals.

## 8. Character Display

Design display modules to be easily removable without the use of tools. Position cooling fans so they do not prevent removal of an LED pixel board or driver board.

Use continuous current to drive the LEDs at the maximum brightness level. Design the light levels to be adjustable for each DMS / controller so the Engineer may set levels to match the luminance requirements at each installation site.

Design the controller to automatically detect failed LED strings or drivers and initiate a report of the event to the Control Software. Design the controller to be able to read the internal temperature of the DMS enclosure and the ambient temperature outside the DMS enclosure and report these to the Control Software.

## 9. Display Capabilities

Design the DMS with at least the following message displays:

- Static display
- Flashing display with Dynamic flash rates
- At least two alternating Static and / or Flashing sequences (multi-page messages)

#### **10. DMS Mini Controller**

Furnish and install a mini controller inside the DMS that is interconnected with the main controller using a fiber optic cable, CAT-5 cable, or an approved alternate. The mini controller will enable a technician to perform all functions available from the main controller. Provide the mini controller with an LCD /keypad interface. Size the LCD display screen to allow preview of an entire one-page message on one screen. Provide a 4 X 4 keypad.

Alternatively, install an EIA/TIA-232E port inside the DMS enclosure to enable a maintenance technician to communicate with the DMS main controller and obtain access to and perform all functions of the main controller using a laptop computer.

#### **C. DMS Enclosure Structure Mounting**

Mount the DMS enclosure and interconnect system securely to the support structures. Design the DMS enclosure supports to allow full access to the DMS enclosure inspection door.

Furnish and install U-bolt connections of hanger beams to overhead assembly truss chords with a double nut at each end of the U-bolt. Bring the double nuts tight against each other by the use of two wrenches.

Submit plans for the DMS enclosure, mounting description, and calculations to the Engineer for approval. Have such calculations and drawings approved by a Professional Engineer registered in the state of North Carolina, and bear his signature, seal, and date of acceptance.

Provide removable lifting eyes or the equivalent on the DMS enclosure rated for its total weight to facilitate handling and mounting the DMS enclosure.

Design the DMS structure to conform to the applicable requirements of the 2013 AASHTO *Standard Specifications for Structural Supports for Highway Signs, Luminaries, and Traffic Signals*, 6th Edition, and the 2013 and 2015 Interim Revisions, and the section titled *DMS Pedestal Structure* of this Project Special Provision.

#### **D. DMS / DMS Controller Interconnect**

Furnish and install all necessary cabling, conduit, and terminal blocks to connect the DMS and the DMS controller. Use approved manufacturer's specifications and the plans developed by the Design-Build Team for cable and conduit types and sizes. Use fiber optic cable to interconnect sign and controller. Install fiber optic interconnect centers in the sign enclosure and cabinet to securely install and terminate the fiber optic cable. Submit material submittal cut sheets for the interconnect center.

#### **E. DMS Controller and Cabinet**

Furnish and install one DMS controller with accessories per DMS in a new equipment cabinet. Mount the controller cabinet on the DMS support structure. Install cabinet so that the height from the ground to the middle of the cabinet is four feet. Ensure a minimum of three-foot level working surface under each cabinet that provides maintenance technicians with a safe working environment.

Provide the DMS controller as a software oriented microprocessor and with resident software stored in non-volatile memory. The Control Software, controller and communications must comply with the NTCIP Standards identified in these Project Special Provisions. Provide sufficient non-volatile memory to allow storage of at least 500 multi-page messages and a test pattern program.

Furnish the controller cabinet with, but not limited to, the following:

- Power supply and distribution assembly
- Power line filtering hybrid surge protectors
- Radio Interference Suppressor
- Communications surge protection devices
- Industrial-Grade UPS system and local disconnect
- Microprocessor-based controller
- Display driver and control system (unless integral to the DMS)
- Serial interface port for local laptop computer
- Local user interface
- Interior lighting and duplex receptacle
- Adjustable shelves as required for components
- Temperature control system
- All interconnect harnesses, connectors, and terminal blocks
- All necessary installation and mounting hardware

Furnish the DMS controller and associated equipment completely housed in a NEMA 3R cabinet made from 5052 H32 sheet aluminum at least 1/8" thick. Use natural aluminum cabinets. Perform all welding of aluminum and aluminum alloys in accordance with the latest edition of AWS D1.2, Structural Welding Code - Aluminum. Continuously weld the seams using Gas Metal Arc Welding (GMAW).

Slant the cabinet roof away from the front of the cabinet to prevent water from collecting on it.

Do not place a manufacturer name, logo, or other information on the faces of the controller cabinet visible to the motorist.

Provide cabinets capable of housing the components and sized to fit space requirement. Design the cabinet layout for ease of maintenance and operation, with all components easily accessible. Submit a cabinet layout plan for approval by the Engineer.

Locate louvered vents with filters in the cabinet to direct airflow over the controller and auxiliary equipment, and in a manner, that prevents rain from entering the cabinet. Fit the inside of the cabinet, directly behind the vents, with a replaceable, standard size, commercially available air filter of sufficient size to cover the entire vented area.

Provide a torsionally rigid door with a continuous stainless-steel hinge on the side that permits complete access to the cabinet interior. Provide a gasket as a permanent and weather resistant seal at the cabinet door and at the edges of the fan / exhaust openings. Use a non-absorbent gasket material

that will maintain its resiliency after long term exposure to the outdoor environment. Construct the doors so that they fit firmly and evenly against the gasket material when closed. Provide the cabinet door with louvered vents and air filters near the bottom as described in the paragraph above.

The cabinet shall contain a full-height standard EIA 19-inch rack. The rack shall be secured within the cabinet by mounts at the top and bottom.

The rack shall contain a minimum of one (1) pullout drawer. The drawer shall be suitable for storing manuals and small tools, such as screwdrivers. The drawer shall be able to latch in the out position to function as a laptop / utility shelf.

Provide a convenient location on the inside of the door to store the cabinet wiring diagrams and other related cabinet drawings. Provide a Corbin #2 main door lock made of non-ferrous or stainless-steel material. Key all locks on the project alike, and provide ten keys to the Engineer. In addition, design the handle to permit pad-locking.

Provide the interior of the cabinet with ample space for housing the controller and all associated equipment and wiring; use no more than 75% of the useable space in the cabinet. Provide ample space in the bottom of the cabinet for the entrance and exit of all power, communications, and grounding conductors and conduit.

Arrange the equipment so as to permit easy installation of the cabling through the conduit so that they will not interfere with the operation, inspection, or maintenance of the unit. Provide adjustable metal shelves, brackets, or other support for the controller unit and auxiliary equipment. Leave a three-inch minimum clearance from the bottom of the cabinet to all equipment, terminals, and bus bars.

Provide power supply monitoring circuitry to detect power failure and to automatically report the occurrence to the Control Software.

Install two 15-watt fluorescent light strips with shields, one in the top of the cabinet and the other under the bottom shelf. Design both lights to automatically turn on when the cabinet door is opened and turn off when the door closes.

Mount and wire a 120V (+10%) GFCI duplex receptacle of the 3-wire grounding type in the cabinet in a location that presents no electrical hazard when used by service personnel for the operation of power tools and work lights.

No cabinet resident equipment shall utilize the GFCI receptacle. Furnish one spare non-GFCI receptacle for future equipment.

Mount a bug-proof and weatherproof thermostatically controlled fan and safety shield in the top of the cabinet. Size the fan to provide at least for two air exchanges per minute. Fuse the fan at 125% of the capacity of the motor. The magnetic field of the fan motor must not affect the performance of the control equipment. Use a fan thermostat that is manually adjustable to turn on between 80°F and 160°F with a differential of not more than 10°F between automatic turn-on and turn-off. Mount it in an easily accessible location, but not within six inches of the fan.

Install additional fans and / or heaters as needed to maintain the temperature inside the cabinet within the operating temperature range of the equipment within the cabinet as recommended by equipment manufacturer(s).



## 1. Wiring

The requirements stated herein apply wherever electrical wiring is needed for any DMS system assemblies and subassemblies such as controller cabinet, DMS enclosure, electrical panel boards etc.

Neatly arrange and secure the wiring inside the cabinet. Where cable wires are clamped to the walls of the control cabinet, provide clamps made of nylon, metal, plastic with rubber or neoprene protectors, or similar. Lace and jacket all harnesses, or tie them with nylon tie wraps spaced at six inches maximum to prevent separation of the individual conductors.

Individually and uniquely label all conductors. Ensure all conductor labels are clearly visible without moving the conductor. Connect all terminal conductors to the terminal strip in right angles. Remove excess conductor before termination of the conductor. Mold the conductor in such a fashion as to retain its relative position to the terminal strip if removed from the strip. Do not run a conductor across a work surface with the exception of connecting to that work surface. No conductor bundles can be support by fasteners that support work surfaces. Install all connectors, devices, and conductors in accordance to manufactures guidelines. Comply with the latest NEC guideline in effect during installation. No conductor or conductor bundle may hang loose or create a snag hazard. Protect all conductors from damage. Ensure all solder joints are completed using industry accepted practices and will not fail due to vibration or movement. Protect lamps and control boards from damage.

No splicing will be allowed for feeder conductors and communication cables from the equipment cabinet to the DMS enclosure.

Insulate all conductors and live terminals so they are not hazardous to maintenance personnel.

Route and bundle all wiring containing line voltage AC and / or shield it from all low voltage control circuits. Install safety covers to prevent accidental contact with all live AC terminals located inside the cabinet.

Use industry standard, keyed-type connectors with a retaining feature for connections to the controller.

Label all equipment and equipment controls clearly.

Supply each cabinet with one complete set of wiring diagrams that identify the color-coding or wire tagging used in all connections. Furnish a water-resistant packet adequate for storing wiring diagrams, operating instructions, and maintenance manuals with each cabinet.

## 2. Power Supply and Circuit Protection

Design the DMS and controller for use on a system with a line voltage of 120V + 10% at a frequency of 60 Hz + 3 Hz. Under normal operation, do not allow the voltage drop between no load and full load of the DMS and its controller to exceed 3% of the nominal voltage.

Blackout, brownout, line noise, chronic over-voltage, sag, spike, surge, and transient effects are considered typical AC voltage defects. Protect the DMS system equipment so that these defects do not damage the DMS equipment or interrupt their operation. Equip all cabinets with devices to protect the equipment in the cabinet from damage due to lightning and external circuit power and current surges.

### 3. Power Supply and Circuit Protections

Protect the DMS controller, accessories, and cabinet utilities with thermal magnetic circuit breakers. Provide the controller cabinet with a main circuit breaker sized according to the NEC. Use appropriately sized branch circuit breakers to protect the controller and accessories and for servicing DMS equipment and cabinet utilities.

### 4. Surge Suppressor

Install and clearly label filtering hybrid power line surge protectors on the load side of the branch circuit breakers in a manner that permits easy servicing. Ground and electrically bond the surge protector to the cabinet within two inches.

Provide power line surge protector that meets the following requirements:

Peak surge current occurrences	20 minimum
Peak surge current for an 8 x 20 microsecond wave-shape	50,000 amperes
Energy Absorption	> 500 Joules
Clamp voltage	240 volts
Response time	<1 nanosecond
Minimum current for filtered output	15 amperes for 120VAC *
Temperature range	-40° F to +158° F

\*Capable of handling the continuous current to the equipment

### 5. Radio Interference Suppressor

Provide each controller cabinet with sufficient electrical and electronic noise suppression to enable all equipment in it to function properly. Provide one or more radio interference suppressors (RIS) connected between the stages of the power line surge suppressor that minimize interference generated in the cabinet in both the broadcast and the aircraft frequencies. Each RIS must provide a minimum attenuation of 50 decibels over a frequency range of 200 KHz to 75 MHz. Clearly label the suppressor(s) and size them at least at the rated current of the main circuit breaker but not less than 50 amperes.

Provide RIS that are hermetically sealed in a substantial metal case which is filled with a suitable insulating compound and have nickel-plated 10/24 brass stud terminals of sufficient external length to provide space to connect #8 AWG wires. Mount them so that the studs cannot be turned in the case. Properly insulate ungrounded terminals from each other, and maintain a surface linkage distance of not less than 1/4" between any exposed current conductor and any other metallic parts. The terminals must have an insulation factor of 100-200 MΩ, dependent on external circuit conditions. Use RIS designed for 120 VAC + 10%, 60Hz, and which meet the standards of UL and the Radio Manufacturers Association.

U-4405

TS-91

Cumberland County

### 6. Communications Surge Protector

Equip the cabinet with properly labeled hybrid data line surge protectors that meet the following general requirements:

Surge current occurrences at 2000 ampere, 8 x 20 microsecond	> 80
Surge current occurrences at 400 ampere, 10x700 microsecond	> 80
Peak surge current for 8 x 20 microsecond waveform	10,000 A (2500 A/line)
Peak surge current for 10x700 microsecond	500 A/line
Response time	< 1 nanosecond
Series resistance	< 15 $\Omega$
Average capacitance	1500 pF
Temperature range	-10°F to 150°F
Clamp Voltage	As required to match equipment in

### 7. Lightning Arrester

Protect the system with an UL-approved lightning arrester installed at the main service disconnect. It shall meet the following requirements:

Type of design	Silicon Oxide Varistor
Voltage	120 / 240 Single phase, 3 wires
Maximum current	100,000 amps
Maximum energy	3000 joules per pole
Maximum number of surges	Unlimited
Response time one milliamp test	5 nanoseconds
Response time to clamp 10,000 amps	10 nanoseconds
Response time to clamp 50,000 amps	25 nanoseconds
Leak current at double the rated voltage	None
Ground Wire	Separate

### 8. Uninterruptible Power Supply (UPS)

Provide the cabinet with an industrial grade power conditioning UPS unit to supply continuous power to operate the equipment connected to it if the primary power fails. The UPS must detect a power failure and provide backup power within 20 milliseconds. Transition to the UPS source from primary power must not cause loss of data or damage to the equipment being supplied with backup power. Provide an UPS with at least three outlets for supplying conditioned AC voltage to the DMS controller. Provide a unit to meet the following requirements:

**U-4405****TS-92****Cumberland County**

- Input Voltage Range: 120VAC +12%, -25%
- Power Rating: 1000 VA, 700 Watts
- Input Frequency: 45 to 65 Hz
- Input Current: 7.2A
- Output Voltage: 120VAC +/- 3%
- Output Frequency: 50/60 +/-1 Hz
- Output Current: 8.3A
- Output Crest Factor Ration: @50% Load Up to 4.8:1  
@75% Load Up to 3.2:1  
@100% Load Up to 2.4:1
- Output THD: 3% Max. (Linear)  
5% Max. (Non-Linear)
- Output Overload: 110% for 10 min; 200% for 0.05 sec.
- Output Dynamic Response: +/- 4% for 100% Step Load Change  
0.5 ms Recovery Time.
- Output Efficiency @ 100% Load: 90% (Normal Mode)
- Operating Temperature: -40°F to +165°F
- Humidity: 0% to 95% Non-condensing

**U-4405****TS-93****Cumberland County**

- Remote Monitoring Interface: RS-232
- Protection:
  - Input / Output Short Circuit
  - Input / Output Overload
  - Excessive Battery Discharge
- Specifications: UL1778, FCC Class A, IEEE 587

Provide the UPS unit capable of supplying 30 minutes of continuous backup power to the equipment connected to it when this equipment is operating at full load.

### **9. Controller Communications Interface**

Provide the controller with the following interface ports:

- An EIA/TIA-232E port for remote communication using NTCIP
- An 10/100 Ethernet port for remote communication using NTCIP
- An EIA/TIA-232E port for onsite access using a laptop
- An EIA/TIA-232E auxiliary port for communication with a field device such as a UPS
- Fiber Optic ports for communication with the sign
- RJ45 ports for communication with the sign using CAT-5 cable
- RJ45 ports for communication with mini-controller located inside the sign enclosure

### **10. Controller Local User Interface**

Provide the controller with a Local User Interface (LUI) for at least the following functions:

- On / Off Switch: controls power to the controller.
- Control Mode Switch: for setting the controller operation mode to either remote or local mode.
- LCD Display and Keypad: Allow user to navigate through the controller menu for configuration (display, communications parameter, etc.) running diagnostics, viewing peripherals status, message creation, message preview, message activation, etc. Furnish a LCD display with a minimum size of 240x64 dots with LED back light.

### **11. Controller Address**

Assign each DMS controller a unique address. Preface all commands from the Control Software with a particular DMS controller address. The DMS controller compares its address with the address transmitted; if the addresses match, then the controller processes the accompanying data.

### **12. Controller Functions**

Design the DMS controller to continuously control and monitor the DMS independent of the Control Software. Design the controller to display a message on the sign sent by the Control

Software, a message stored in the sign controller memory, or a message created on-site by an operator using the controller keypad. Provide the DMS controller with a watchdog timer to detect controller failures and to reset the microprocessor, and with a battery backed-up clock to maintain an accurate time and date reference. Set the clock through an external command from the Control Software or the Local User Interface.

### **13. DMS Controller Memory**

Furnish each DMS controller with non-volatile memory. Use the non-volatile memory to store and reprogram at least one test pattern sequence and 500 messages containing a minimum of two pages of 45 characters per page. The Control Software can upload messages into and download messages from each controller's non-volatile memory remotely.

Messages uploaded and stored in the controller's non-volatile memory may be erased and edited using the Control Software and the controller. New messages may be uploaded to and stored in the controller's non-volatile memory using the Control Software and the controller.

### **F. Photo-Electric Sensors**

Install three photoelectric sensors with ½-inch minimum diameter photosensitive lens inside the DMS enclosure. Use sensors that will operate normally despite continual exposure to direct sunlight. Place the sensors so they are accessible and field adjustable.

Point one sensor north or bottom of the sign. Place the other two, one on the back wall and one on the front wall of the sign enclosure. Alternate designs maybe accepted, provided the sensor assemblies are accessible and serviceable from inside the sign enclosure.

Provide controls so that the Engineer can field adjust the following:

- The light level emitted by the pixels elements in each Light Level Mode.
- The ambient light level at which each Light Level Mode is activated.

### **G. Equipment List**

Provide a general description of all equipment and all information necessary to describe the basic use or function of the major system components. Include a general "block diagram" presentation. Include tabular charts listing auxiliary equipment, if any is required. Include the nomenclature, physical and electrical characteristics, and functions of the auxiliary equipment unless such information is contained in an associated manual; in this case include a reference to the location of the information. Include an itemized list of equipment costs.

Include a table itemizing the estimated average and maximum power consumption for each major piece of equipment.

### **H. Physical Description**

Provide a detailed physical description of size, weight, center of gravity, special mounting requirements, electrical connections, and all other pertinent information necessary for proper installation and operation of the equipment.

### **I. Parts List**

Provide a parts list that contains all information needed to describe the characteristics of the individual parts, as required for identification. Include a list of all equipment within a group and a list of all assemblies, sub-assemblies, and replacement parts of all units.

Arrange this data in a table, in alpha-numerical order of the schematic reference symbols, which gives the associated description, manufacturer's name, and part number, as well as alternate manufacturers and part numbers. Provide a table of contents or other appropriate grouping to identify major components, assemblies, etc.

#### **J. Character Set Submittal**

Submit an engineering drawing of the DMS character set including 26 upper case and lower-case letters, 10 numerals, an asterisk (\*), a dash, a plus sign (+), a designated lane diamond, a slash, an ampersand, and arrows at 0, 45, 90, 135, 180, 225, 270, and 315 degrees.

#### **K. Wiring Diagrams**

Provide a wiring diagram for each DMS and each controller cabinet, as well as interconnection wiring diagrams for the system as a whole.

Provide complete and detailed schematic diagrams to component level for all DMS assemblies and subassemblies such as driver boards, control boards, DMS controller, power supplies, etc. Ensure that each schematic enables an electronics technician to successfully identify any component on a board or assemblies and trace its incoming and outgoing signals.

#### **L. Routine Of Operation**

Describe the operational routine, from necessary preparations for placing the equipment into operation to securing the equipment after operation. Show appropriate illustrations with the sequence of operations presented in tabular form wherever applicable. Include in this section a total list of the test instruments, aids and tools required to perform necessary measurements and measurement techniques for each component, as well as set-up, test, and calibration procedures.

#### **M. Maintenance Procedures**

Specify the recommended preventative maintenance procedures and checks at pre-operation, monthly, quarterly, semi-annual, annual, and "as required" periods to assure equipment operates reliably. List specifications (including tolerances) for all electrical, mechanical, and other applicable measurements and / or adjustments.

#### **N. Repair Procedures**

Include in this section all data and step-by-step procedures necessary to isolate and repair failures or malfunctions, assuming the maintenance technicians are capable of analytical reasoning using the information provided in the sections titled *Wiring Diagrams* and *Routine of Operation*.

Describe accuracy, limits, and tolerances for all electrical, physical, or other applicable measurements. Include instructions for disassemblies, overhaul, and re-assemblies, with shop specifications and performance requirements.

Give detailed instructions only where failure to follow special procedures would result in damage to equipment, improper operation, danger to operating or maintenance personnel, etc. Include such instructions and specifications only for maintenance that specialized technicians and engineers in a modern electromechanical shop would perform. Describe special test set-up, component fabrication, and the use of special tools, jigs, and test equipment.

**O. Field Trial**

At the request of the Engineer, supply a three-character demonstration module with characters of the size and type specified for the project, an appropriate control device and power supply to allow character display within 30 working days of the request. Perform a field trial on this module at a time and location selected by the Engineer.

This trial will allow the Engineer or his selected representatives to test the readability of the DMS at the maximum distance required for specified character size. Test the module with the sun directly above the DMS, and near the horizon in front of and behind the DMS (washout and back-lit conditions).

**12.3. CONSTRUCTION METHODS****A. Description**

This article establishes practices and procedures and gives minimum standards and requirements for the installation of Dynamic Message Sign systems, auxiliary equipment and the construction of related structures.

Provide electrical equipment described in this specification that conforms to the standards of NEMA, UL, or Electronic Industries Association (EIA), wherever applicable. Provide connections between controllers and electric utilities that conform to NEC standards.

Express wire sizes according to the American Wire Gauge (AWG).

Provide stainless steel screws, nuts, and locking washers in all external locations. Do not use self-tapping screws unless specifically approved by the Engineer. Use parts made of corrosion-resistant materials, such as plastic, stainless steel, brass, or aluminum. Use construction materials that resist fungus growth and moisture deterioration. Separate dissimilar metals by an inert dielectric material.

**B. Layout**

The Engineer will establish the actual location of each Dynamic Message Sign assembly. It is the Contractor's responsibility to ensure proper elevation, offset, and orientation of all DMS assemblies. The location of service poles as well as conduit lengths shown in the project plans, are approximate based on available project data. Make actual field measurements to place conduit and equipment at the required location.

**C. Construction Submittal**

When the work is complete, submit As Built Plans, inventory sheets, and any other data required by the Engineer to show the details of actual construction and installation and any modifications made during installation.

The As-Built Plans shall show: the DMS, controller, and service pole locations; DMS enclosure and controller cabinet wiring layouts; and wire and conduit routing. Show all underground conduits and cables dimensioned from fixed objects.

Include detailed drawings that identify the routing of all conductors in the system by cable type, color code, and function. Clearly label all equipment in the DMS system, controller cabinet, and DMS enclosure.



U-4405

TS-97

Cumberland County

**D. Conduit**

Install the conduit system in accordance with Section 1715 of the 2012 *Standard Specifications for Roads and Structures* and NEC requirements for an approved watertight raceway.

Make bends in the conduit so as not to damage it or change its internal diameter. Install watertight and continuous conduit with as few couplings as standard lengths permit.

Clean conduit before, during, and after installation. Install conduit in such a manner that temperature changes will not cause elongation or contraction that might damage the system.

Attach the conduit system to and install along the structural components of the DMS structure assemblies with beam clamps or stainless-steel strapping. Install strapping according to the strapping manufacturer's recommendations. Do not use welding or drilling to fasten conduit to structural components. Space the fasteners at no more than 4 feet for conduit 1.5 inches and larger or 6 feet for conduit smaller than 1.25 inches. Place fasteners no more than 3 feet from the center of bends, fittings, boxes, switches, and devices.

Locate underground conduit as shown in the plans in a manner consistent with these Project Special Provisions.

Do not exceed the appropriate fill ratio on all cable installed in conduit as specified in the NEC.

**E. Wiring Methods**

Do not pull permanent wire through a conduit system until the system is complete and has been cleaned.

Color-code all conductors per the NEC. Use approved marking tape, paint, sleeves or continuous colored conductors for No.8 AWG and larger. Do not mark a white conductor in a cable assemblies any other color.

Bury underground circuits at the depth shown in the plans and surround it with at least three inches of sand or earth back-fill free of rocks and debris. Compact backfill in six-inch layers. Do not splice underground circuits unless specifically noted in the project plans and approved by the Department.

**F. Equipment and Cabinet Mounting**

Mount equipment securely at the locations shown in the plans and, in conformance with the dimensions shown. Install fasteners as recommended by the manufacturer and space them evenly. Use all mounting holes and attachment points for attaching DMS enclosures and controller cabinets to the structures.

Drill holes for expansion anchors of the size recommended by the manufacturer of the anchors and thoroughly clean them of all debris.

Provide one key-operated, pin tumbler, dead bolt padlock, with brass or bronze shackle and case, conforming to Military Specification MIL-P-17802E (Grade I, Class 2, Size 2, Style A) for each electrical panel and switch on the project. Key all padlocks alike, and provide ten keys to the Engineer.

Provide cabinets with all mounting plates, anchor bolts, and any other necessary mounting hardware in accordance with these Project Special Provisions.

Seal all unused conduit installed in cabinets at both ends to prevent water and dirt from entering the conduit and cabinet with approved sealing material.

Install a ground bushing attached inside the cabinet on all metal conduits entering the cabinet. Connect these ground bushings to the cabinet ground bus.

Install a level concrete technician pad measuring a minimum 4 inches thick, 24 inches wide and 36 inches long at the front door of the DMS equipment cabinet as shown on the Typical Details sheet within the Project Plans.

**G. Work Site Clean-Up**

Clean the site of all debris, excess excavation, waste packing material, wire, etc. Clean and clear the work site at the end of each workday. Do not throw waste material in storm drains or sewers.

**12.4. MEASUREMENT AND PAYMENT**

*Dual DMS Mounted Back to Back* will be measured and paid as the actual number of DMS's furnished, installed, and accepted. The Dual DMS setup will consist of both LED Dynamic Message Signs, spare display modules, communications equipment, strapping hardware, controller, UPS, controller cabinet, concrete technician pad, conduit, fittings, couplings, sweeps, conduit bodies, wire, flexible conduit, feeder conductors and communications cable between the controller cabinet and the DMS enclosure, connectors, circuit protection equipment, photo-electric sensors, tools, materials, all related testing, cost of labor, cost of transportation, incidentals, and all other equipment necessary to furnish and install the DMS system.

Payment will be made under:

Dual DMS Mounted Back to Back.....Each

**13. NTCIP Requirements**

This section defines the detailed NTCIP requirements for the DMSs covered by these Project Special Provisions and Plans.

**13.1. REFERENCES**

This specification references several standards through their NTCIP designated names. The following list provides the full reference to the current version of each of these standards.

Implement the most recent version of the standard including any and all Approved or Recommended Amendments to these standards for each NTCIP Component covered by these project specifications.

**Table 1: NTCIP Standards**

Abbreviated Number	Full Number	Title
NTCIP 1101	NTCIP 1101:1997	<i>Simple Transportation Management Framework</i>

U-4405

TS-99

Cumberland County

<b>Abbreviated Number</b>	<b>Full Number</b>	<b>Title</b>
NTCIP 1201	<b>NTCIP 1201:1997</b>	<i>Global Object Definitions</i>
NTCIP 1203	<b>NTCIP 1203:1997</b>	<i>Object Definitions for Dynamic Message Signs</i>
NTCIP 2001	<b>NTCIP 2001:1997</b>	<i>Class B Profile</i>
NTCIP 2101	<b>NTCIP 2101</b>	<i>SP-PMPP/232 Subnet Profile for PMPP over RS-232</i>
NTCIP 2102	<b>NTCIP 2102</b>	<i>SP-PMPP/FSK Subnet Profile for PMPP over FSK Modem</i>
NTCIP 2103	<b>NTCIP 2103</b>	<i>SP-PPP/232 Subnetwork Profile for PPP over RS232 (Dial Up)</i>
NTCIP 2104	<b>NTCIP 2104</b>	<i>SP-Ethernet Subnet Profile for Ethernet</i>
NTCIP 2201	<b>NTCIP 2201</b>	<i>TP-Null Transport Profile</i>
NTCIP 2202	<b>NTCIP 2202</b>	<i>TP-Internet Internet Transport Profile (TCP/IP and UDP/IP)</i>
NTCIP 2301	<b>NTCIP 2301</b>	<i>AP-STMF AP for Simple Transportation Management Framework</i>

## A. General Requirements

### 1. Subnet Level

Ensure each serial port on each NTCIP Component supports NTCIP 2103 over a dial-up connection with a contractor provided external modem with data rates of 28.8 kbps, 19.2 kbps, 14.4 kbps, 9600 bps, 4800 bps, 2400 bps, 1200 bps, 600 bps, and 300 bps. Enable the NTCIP Component to make outgoing and receive incoming calls as necessary and support the following modem command sets:

- Hayes AT - Command Set
- MNP5
- MNP10
- V.42bis

Ensure each serial port on each NTCIP Component supports NTCIP 2103 over a null-modem connection with data rates of 19.2 kbps, 14.4 kbps, 9600 bps, 4800 bps, 2400 bps, 1200 bps, 600 bps, and 300 bps.

Ensure each serial port on each NTCIP Component supports NTCIP 2101 with data rates of 9600 bps, 4800 bps, 2400 bps, 1200 bps, 600 bps, and 300 bps.

Ensure NTCIP components support NTCIP 2102 and NTCIP 2104.

NTCIP Components may support additional Subnet Profiles at the manufacturer's option. At any one time, make certain only one Subnet Profile is active on a given serial port of the NTCIP Component. Ensure the NTCIP Component can be configured to allow the field technician to activate the desired Subnet Profile and provide a visual indication of the currently selected Subnet Profile.

## **2. Transport Level**

Ensure each NTCIP Component complies with NTCIP 2201 and 2202.

NTCIP Components may support additional Transport Profiles at the manufacturer's option. Ensure Response datagrams use the same Transport Profile used in the request. Ensure each NTCIP Component supports the receipt of datagrams conforming to any of the identified Transport Profiles at any time.

## **3. Application Level**

Ensure each NTCIP Component complies with NTCIP 1101 and 2301 and meets the requirements for Conformance Level 1 (NOTE - See Amendment to standard).

Ensure each NTCIP Component supports SNMP traps. An NTCIP Component may support additional Application Profiles at the manufacturer's option. Ensure Responses use the same Application Profile used by the request. Ensure each NTCIP Component supports the receipt of Application data packets at any time allowed by the subject standards.

## **4. Information Level**

Guarantee each NTCIP Component provides Full, Standardized Object Range Support of all objects required by these Special Provisions unless otherwise indicated below. Make certain the maximum Response Time for any object or group of objects is 200 milliseconds.

Design the DMS to support all mandatory objects of all mandatory Conformance Groups as defined in NTCIP 1201 and NTCIP 1203. Table 2 indicates the modified object requirements for these mandatory objects.

**Table 2: Modified Object Ranges for Mandatory Objects**

U-4405

TS-101

Cumberland County

Object	Reference	Project Requirement
ModuleTableEntry	NTCIP 1201 Clause 2.2.3	Contains at least one row with moduleType equal to 3 (software). The moduleMake specifies the name of the manufacturer, the moduleModel specifies the manufacturer's name of the component and the modelVersion indicates the model version number of the component.
MaxGroupAddresses	NTCIP 1201 Clause 2.7.1	At least 1
CommunityNamesMax	NTCIP 1201 Clause 2.8.2	At least 3
DmsNumPermanentMsg	NTCIP 1203 Clause 2.6.1.1.1.1	At least 1*
DmsMaxChangeableMsg	NTCIP 1203 Clause 2.6.1.1.1.3	At least 21
DmsFreeChangeableMemory	NTCIP 1203 Clause 2.6.1.1.1.4	At least 20 when no messages are stored.
DmsMessageMultiString	NTCIP 1203 Clause 2.6.1.1.1.8.3	The DMS supports any valid MULTI string containing any subset of those MULTI tags listed in Table 4
DmsControlMode	NTCIP 1203 Clause 2.7.1.1.1.1	Support at least the following modes: Local External central CentralOverride

\* Ensure the Permanent Messages display the content shown in Table 3.

Ensure the sign blanks if a command to display a message contains an invalid Message CRC value for the desired message.

**Table 3: Content of Permanent Messages**

Perm. Msg. Num.	Description
1	Permanent Message #1 blanks the display (i.e., consist

U-4405

TS-102

Cumberland County

	of and empty MULTI string). It has a run-time priority of one (1).
--	--

**Table 4: Required MULTI Tags**

<b>Code</b>	<b>Feature</b>
f1	field 1 - time (12hr)
f2	field 2 - time (24hr)
f8	field 8 – day of month
f9	field 9 – month
f10	field 10 - 2 digit year
f11	field 11 - 4 digit year
fl (and /fl)	flashing text on a line by line basis with flash rates controllable in 0.5 second increments.
fo	Font
j12	Justification – line – left
j13	Justification – line – center
j14	Justification – line – right
j15	Justification – line – full
jp2	Justification – page – top
jp3	Justification – page – middle
jp4	Justification – page – bottom
Mv	moving text
Nl	new line
Np	new page, up to 2 instances in a message (i.e., up to 3 pages/frames in a message counting first page)
Pt	page times controllable in 0.5 second increments.

The NTCIP Component implements all mandatory and optional objects of the following optional conformance groups with FSORS.

U-4405

TS-103

Cumberland County

**5. Test Heading****Time Management**

As defined in NTCIP 1201

**Timebase Event Schedule**

As defined in NTCIP 1201. The following list indicates the modified object requirements for this conformance group.

**Table 5: Modified Object Ranges for the Timebase Event Schedule Conformance Group**

Object	Reference	Project Requirement
MaxTimeBaseScheduleEntries	NTCIP 1201 Clause 2.4.3.1	At least 28
maxDayPlans	NTCIP 1201 Clause 2.4.4.1	At least 14
maxDayPlanEvents	NTCIP 1201 Clause 2.4.4.2	At least 10

**Report**

As defined in NTCIP 1201. The following list indicates the modified object requirements for this conformance group.

**Table 6: Modified Object Ranges for the Report Conformance Group**

Object	Reference	Project Requirement
maxEventLogConfigs	NTCIP 1201 Clause 2.5.1	At least 50
eventConfigurationMode	NTCIP 1201 Clause 2.4.3.1	The NTCIP Component supports the following Event Configuration Modes: onChange greaterThanValue smallerThanValue
MaxEventLogSize	NTCIP 1201 Clause 2.5.3	At least 200
MaxEventClasses	NTCIP 1201 Clause 2.5.5	At least 16

**PMPP****Font Configuration**

As defined in NTCIP 1203. The following list indicates the modified object requirements for this conformance group.

**Table 7: Modified Object Ranges for the Font Configuration Conformance Group**

Object	Reference	Project Requirement
--------	-----------	---------------------

U-4405

TS-104

Cumberland County

NumFonts	NTCIP 1203 Clause 2.4.1.1.1.1	At least 4*
MaxFontCharacters	NTCIP 1203 Clause 2.4.1.1.1.3	At least 127**

\*Upon delivery, the first font is a standard 18” font. The second font is a double-stroke 18” font. The third font is a 28” font. The fourth font is empty.

\*\*Upon delivery, the first three font sets are configured in accordance with the ASCII character set for the following characters:

- “A” thru “Z”- All upper case letters.
- “0” thru “9”- All decimal digits.
- Space (i.e., ASCII code 0x20).
- Punctuation marks shown in brackets [ . , ! ? - ‘ ’ “ ” / ( ) ]
- Special characters shown in brackets [# & \* + < > ]

### DMS Configuration

As defined in NTCIP 1203.

### MULTI Configuration

As defined in NTCIP 1203. The following list indicates the modified object requirements for this conformance group.

**Table 8: Modified Object Ranges for the MULTI Configuration Conformance Group**

Object	Reference	Project Requirement
DefaultBackgroundColor	NTCIP 1203 Clause 2.5.1.1.1.1	The DMS supports the following background colors: black
DefaultForegroundColor	NTCIP 1203 Clause 2.5.1.1.1.2	The DMS supports the following foreground colors: amber
DefaultJustificationLine	NTCIP 1203 Clause 2.5.1.1.1.6	The DMS supports the following forms of line justification: left center right full



U-4405

TS-105

Cumberland County

defaultJustificationPage	NTCIP 1203 Clause 2.5.1.1.1.7	The DMS supports the following forms of page justification: top middle bottom
defaultPageOnTime	NTCIP 1203 Clause 2.5.1.1.1.8	The DMS supports the full range of these objects with step sizes no larger than 0.5 seconds
defaultPageOffTime	NTCIP 1203 Clause 2.5.1.1.1.9	The DMS supports the full range of these objects with step sizes no larger than 0.5 seconds
defaultCharacterSet	NTCIP 1203 Clause 2.5.1.1.1.10	The DMS supports the following character sets: eightBit

**Default Message Control** as defined in NTCIP 1203

**Pixel Service Control** as defined in NTCIP 1203

**MULTI Error Control** as defined in NTCIP 1203

**Illumination/Brightness Control**

As defined in NTCIP 1203. The following list indicates the modified object requirements for this conformance group.

**Table 9: Modified Object Ranges for the Illumination/Brightness Control Conformance Group**

Object	Reference	Project Requirement
dmsIllumControl	NTCIP 1203 Clause 2.8.1.1.1.1	The DMS supports the following illumination control modes: photocell timer manual
dmsIllumNumBrightLevels	NTCIP 1203 Clause 2.8.1.1.1.4	At least 16

**Auxiliary I/O**

**Scheduling**

As defined in NTCIP 1203. The following list indicates the modified object requirements for this conformance group.

U-4405

TS-106

Cumberland County

**Table 10: Modified Object Ranges for the Scheduling Conformance Group**

<b>Object</b>	<b>Reference</b>	<b>Project Requirement</b>
NumActionTableEntries	NTCIP 1203 Clause 2.9.1.1.1.1	At least 21

**Sign Status** as defined in NTCIP 1203

**Status Error** as defined in NTCIP 1203

**Pixel Error Status** as defined in NTCIP 1203

**Fan Error Status** as defined in NTCIP 1203

**Power Status** as defined in NTCIP 1203

**Temperature Status** as defined in NTCIP 1203

Install necessary hardware for the support of items q, r, and s above.

**Table 11: Some Optional Object Requirements**

<b>Object</b>	<b>Reference</b>	<b>Project Requirement</b>
DefaultFlashOn	NTCIP 1203 Clause 2.5.1.1.1.3	The DMS supports the full range of these objects with step sizes no larger than 0.5 seconds
DefaultFlashOff	NTCIP 1203 Clause 2.5.1.1.1.4	The DMS supports the full range of these objects with step sizes no larger than 0.5 seconds
DmsMultiOtherErrorDescription	NTCIP 1203 Clause 2.7.1.1.1.20	If the vendor implements any vendor-specific MULTI tags, the DMS shall provide meaningful error messages within this object whenever one of these tags generates an error.

## 6. Documentation

Supply software with full documentation, including a CD-ROM containing ASCII versions of the following MIB files in Abstract Syntax Notation 1 (ASN.1) format:

- The relevant version of each official standard MIB Module referenced by the device functionality.
- If the device does not support the full range of any given object within a Standard MIB Module, a manufacturer specific version of the official Standard MIB Module with the supported range indicated in ASN.1 format in the SYNTAX and/or DESCRIPTION fields of the associated OBJECT TYPE macro. Name this file identical to the standard MIB Module, except that it will have the extension ".man".
- A MIB Module in ASN.1 format containing any and all manufacturer-specific objects supported by the device with accurate and meaningful DESCRIPTION fields and supported ranges indicated in the SYNTAX field of the OBJECT-TYPE macros.
- A MIB containing any other objects supported by the device.

Allow the use of any and all of this documentation by any party authorized by the Department for systems integration purposes at any time initially or in the future, regardless of what parties are involved in the systems integration effort.

## B. NTCIP Acceptance Testing

Test the NTCIP requirements outlined above by a third party testing firm. Submit to the Engineer for approval a portfolio of the selected firm. Include the name, address, and a history of the selected firm in performing NTCIP testing along with references. Also provide a contact person's name and phone number. Submit detailed NTCIP testing plans and procedures, including a list of hardware

**U-4405****TS-108****Cumberland County**

and software, to the Engineer for review and approval 10 days in advance of a scheduled testing date. Develop test documents based on the NTCIP requirements of these Project Special Provisions. The acceptance test will use the NTCIP Exerciser, and/or other authorized testing tools and will follow the guidelines established in the ENTERPRISE Test Procedures. Conduct the test in North Carolina on the installed system in the presence of the Engineer. Document and certify the results of the test by the firm conducting the test and submit the Engineer for review and approval. In case of failures, remedy the problem and have the firm retest in North Carolina. Continue process until all failures are resolved. The Department reserves the right to enhance these tests as deemed appropriate to ensure device compliance.

### **13.2. MEASUREMENT AND PAYMENT**

There will be no direct payment for the work covered by this section.

Payment for this work will be covered in the applicable sections of these Project Special Provisions at the contract unit price for "DMS" and will be full compensation for all work listed above.

## **14. DMS ASSEMBLIES**

### **14.1. DESCRIPTION**

This section includes all design, fabrication, furnishing, and erection of the DMS assemblies, and attachment of the DMS enclosures to the structures in accordance with the requirements of these Project Special Provisions and the Plans. Fabricate the supporting DMS assemblies from tubular steel. Furnish pedestal type DMS assemblies as shown in the Plans. Cantilevered and monotube (horizontal truss) DMS structures will not be allowed.

For the two (2) DMS's mounted back to back on a single support structure, provide pedestal structures with a minimum of 18 feet clearance from the high point of the road to the bottom of the DMS enclosure. DMS assemblies must allow for field adjustment with shims (horizontal & vertical tilting) +/- 3 degrees of the DMS enclosure to ensure optimum legibility from all travel lanes.

Design the new DMS assemblies (including footings) and submit shop drawings for approval. A Professional Engineer that is registered in the state of North Carolina will prepare such computations and drawings. These must bear his signature, seal, and date of acceptance.

The provisions of Section 900 of the Standard Specifications apply to all work covered by this section.

It is the Contractor's responsibility to provide DMS S-dimension elevation drawings for the DMS locations to the Engineer for approval.

### **14.2. MATERIAL**

Use materials that meet the following requirements of the Standard Specifications:

Structural Steel	Section 1072
Overhead Sign Structures	Section 1096
Signing Materials	Section 1092
Organic-Zinc Repair Paint	Article 1080-9
Reinforcing Steel	Sub-article 1070
Direct Tension Indicators	Sections 440 and 1072

**U-4405****TS-109****Cumberland County****14.3. CONSTRUCTION METHODS****A. General**

Fabricate the new DMS assemblies, in accordance with the details shown in the approved shop drawings and the requirements of these Project Special Provisions.

No welding, cutting, or drilling in any manner will be permitted in the field, unless approved by the Engineer.

Drill bolt holes and slots to finished size. Holes may also be punched to finished size, provided the diameter of the punched holes are at least twice the thickness of the metal being punched. Flame cutting of bolt holes and slots is not permitted.

Erect DMS in accordance with the requirements indicated on the Plans and in these Project Special Provisions. Field drill two holes per connection in the Z bars for attaching the DMS to the structure. Use two bolts at each connection. Provide two (2) U-bolts at each U-bolt connection such as 1) each truss chord to sign hanger, or 2) each truss chord to platform support. Provide two (2) U-bolts at each U-bolts connection where ends of truss chords are supported. Minimum diameter of all U-bolts is to be ½ inch.

Use two coats of a zinc-rich paint to touch up minor scars on all galvanized materials. See Standard Specifications for Roads and Structures Section 1076-6.

For high strength bolted connections, provide direct tension indicator washer.

**B. Shop Drawing**

Submit to the Engineer for approval a complete design for the DMS assemblies (including footings) DMS assembly hardware, brackets for supporting the DMS to the structure. Base the design on the line drawings and correct wind speed in accordance with the latest edition of AASHTO "Standard Specifications for Structural Supports for Highway Signs, Luminaries and Traffic Signals, 5<sup>th</sup> Edition, 2009" with the latest interim revisions.

The manufacturer of the DMS assembly must ensure that design of the assembly is compatible with the DMSs for mounting and attachment.

Submit six copies of complete detailed shop drawings and one copy of the design computations for the DMS assembly to the Engineer for approval prior to fabrication. Show in the shop drawings complete design and fabrication details including foundations, provisions for attaching the DMS, applicable material specifications, and any other information necessary for procuring and replacing any part of the complete DMS assembly.

Allow a minimum of 40 working days for shop drawing approval after the Engineer receives them. If revised drawings are necessary, allow appropriate additional time for review and approval of final shop drawings.

Approval of shop drawings by the Engineer will not relieve the Contractor of his responsibility for the correctness of drawings, or for the fit of all shop and field connections and anchors.

**C. Design and Fabrication****1. Dynamic Message Sign Assembly**

- Design must be in accordance with the Standard Specifications for Structural Supports for Highway Signs, Luminaires and Traffic Signals, 5<sup>th</sup> Edition, 2009, and the latest Interim Revisions.
- The wind pressure map that is developed from the 3-second gust speeds, as provided in Article 3.8, shall be used.
- The natural wind gust speed in North Carolina shall be assumed to be 5 meters per second or 11.6 mph for inland areas, and 7 meters per second or 15.7 mph for coastal areas. The coastal area shall be defined as any area within 2 miles from the waterfront facing the ocean or sound and all area where the design basic wind speed is above 120 mph, as shown in Figure 3-2.
- The fatigue importance category used in the design, for each type of structure, as provided for in Article 11.6, Fatigue Importance Factors, shall be Category II unless otherwise shown on the contract plans.
- Wind drag coefficient for Dynamic Message Sign enclosures shall be 1.7.

The following Specification interpretations or criteria shall be used in the design of overhead sign assemblies:

- For design of supporting upright posts or columns, the effective length factor for columns “K”, as provided for in Appendix B, Section B.5, shall be taken as the following, unless otherwise approved by the Engineer:
  - Case 1 For a single upright post of span type overhead sign structure, the effective column length factor, “K”, shall be taken as 2.0.
  - Case 2 For twin post truss-type upright post with the post connected to one chord of a horizontal truss, the effective column length factor for that column shall be taken as 2.0.
  - Case 3 For twin post truss-type upright post with the post connected to two truss chords of a horizontal tri-chord or box truss, the effective column length factor for that column shall be taken as 1.65.
- For twin post truss-type upright post, the unbraced length shall be from the chord to post connection to the top of base plate.
- For twin post truss-type upright post that is subject to axial compression, bending moment, shear, and torsion the post shall satisfy Standard Specifications for Structural Supports for Highway Signs, Luminaries and Traffic Signals Equations 5-17, 5-18 and 5-19. To reduce the effects of secondary bending, in lieu of Equation 5-18, the following equation may be used:

$$\frac{f_a}{F_a} + \frac{f_b}{\left(1 - \frac{0.6f_a}{F_e}\right)F_b} + \left(\frac{f_v}{F_v}\right)^2 \leq 1.0$$

Where

fa = Computed axial compression stress at base of post

- The base plate thickness for all uprights and poles shall be a minimum of 2” but not less than that determined by the following criteria and design.
  - Case 1 Circular or rectangular solid base plates with the upright pole welded to the top surface of base plate with full penetration butt weld, and where no stiffeners are provided. A base plate with a small center hole, which is less than 1/5 of the upright diameter, and located concentrically with the upright pole, may be considered as a solid base plate.
 

The magnitude of bending moment in the base plate, induced by the anchoring force of each anchor bolt shall be calculated using equation  $M = (P \times D_1) / 2$ .
  - Case 2 Circular or rectangular base plate with the upright pole socketed into and attached to the base plate with two lines of fillet weld, and where no stiffeners are provided, or any base plate with a center hole that is larger in diameter than 1/5 of the upright diameter.
 

The magnitude of bending moment induced by the anchoring force of each anchor bolt shall be calculated using equation  $M = P \times D_2$ .

    - M, bending moment at the critical section of the base plate induced by one anchor bolt
    - P, anchoring force of each anchor bolt
    - D<sub>1</sub>, horizontal distance between the center of the anchor bolt and the outer face of the upright, or the difference between the radius of the bolt circle and the outside radius of the upright
    - D<sub>2</sub>, horizontal distance between the face of the upright and the face of the anchor bolt nut
- The critical section shall be located at the face of the anchor bolt and perpendicular to the radius of the bolt circle. The overlapped part of two adjacent critical sections shall be considered ineffective.
- The thickness of base plate of Case 1 shall not be less than that calculated based on formula for Case 2.
- Uprights, foundations, and trusses shall be designed in accordance with the DMS Foundation Special Provision for the effects of torsion. Torsion shall be considered from

dead load eccentricity of these attachments, as well as for attachments such as walkway platforms, supporting brackets, etc., that add to the torsion in the assembly. Truss vertical and horizontal truss diagonals in particular and any other assembly members shall be appropriately sized for these loads.

- Uprights, foundations, and trusses shall be designed for the proposed sign wind area and future wind areas. The design shall consider the effect of torsion induced by the eccentric force location of the center of wind force above (or below) the center of the supporting truss. Truss vertical and horizontal truss diagonals in particular and any other assembly members shall be appropriately sized for these loads.

Fabricate the supporting structures using tubular members of either aluminum or steel, using only one type of material throughout the project.

Horizontal components of the supporting structures for overhead DMS must be of a truss design to support the DMS. Truss centerline must coincide with centerline of the DMS design area shown on the structure line drawing. Provide permanent camber in addition to dead load camber in accordance with the "Standard Specifications for Structural Supports for Highway Signs, Luminaires, and Traffic Signals." Indicate on the shop drawings the amount of camber provided and the method employed in the fabrication of the support to obtain the camber.

For all U-bolt connections of hanger beams to overhead assembly truss chords, provide all U-bolts with a flat washer, a lock washer and double nuts at each end of the U-bolts. All double nuts that are on any U-bolt shall be the same thickness and weight. When assembled, the double nuts shall be brought tight against each other by the use of two wrenches.

Fabricate attachment assemblies for the mounting DMS in a manner that allows easy removal of the sign.

**14.4. MEASUREMENT AND PAYMENT**

*DMS Structure* will be measured and paid as the actual number of dynamic message sign assemblies furnished, installed, and accepted. Payment includes all design, fabrication, construction, transportation, and attachment of the complete dynamic message sign assemblies, supporting structure, hardware, direct tension indicators, preparing and furnishing shop drawings, additional documentation, incidentals, and all other equipment and features necessary to furnish the system described above.

Payment will be made under:

<b>Pay Item</b>	<b>Pay Unit</b>
DMS Structure .....	Each

**15. SOIL TEST FOR DMS FOUNDATION**

**15.1. DESCRIPTION**

Perform a soil test for each DMS foundation location according to the requirements described below.

It is assumed that all foundation designs will be drilled pier foundations unless site-specific soil test information does not allow for a drilled pier foundation design. If an alternative foundation



U-4405

TS-113

Cumberland County

design is required, notify the Engineer immediately. Prior approval from the Engineer is required to receive additional compensation for an alternate foundation design.

Design all custom foundations to carry the maximum capacity of each DMS structure.

When poor soil conditions are encountered, which could create an excessively large foundation design, consideration may be given to allowing an exemption to the maximum capacity design. The contractor must gain approval from the Engineer before reducing a foundation's capacity. Where poor soil is known to be present, it is advisable that the contractor receive approval for foundation designs before releasing poles for fabrication.

## 15.2. SOIL TEST

### A. General

Drilled piers are reinforced concrete sections, cast in place against in situ, undisturbed material. Drilled piers are of straight shaft type and vertical.

The contractor-selected pole fabricator is responsible for determining if the addition of wing walls is necessary for the supporting foundations.

### B. Soil Test

Perform a soil test at each proposed DMS pedestal location. Complete all required fill placement and excavation at each pedestal location to finished grade before drilling each boring. Soil tests performed that are not in compliance with this requirement may be rejected and will not be paid. Drill one boring to a depth of 26 feet within a 25-foot radius of each proposed foundation.

Perform standard penetration tests (SPT) in accordance with ASTM D 1586 at depths of 1, 2.5, 5, 7.5, 10, 15, 20 and 26 feet. Discontinue the boring if one of the following occurs:

- A total of 100 blows have been applied in any 2 consecutive 6-in. intervals
- A total of 50 blows have been applied with < 3-in. penetration

Submit completed boring logs collected in accordance with these Project Special Provisions DMS load information to the contractor-selected pedestal fabricator to assist in the pedestal and foundation design.

Describe each DMS pedestal location along the project corridor in a manner that is easily discernible to both the contractor's designer and NCDOT reviewers. If a DMS pedestal is at an intersection, label the boring the "Intersection of (*Route or SR #*), (*Street Name*) and (*Route or SR #*), (*Street Name*), \_\_\_\_\_ County. Label borings with "B- *N, S, E, W, NE, NW, SE or SW*" corresponding to the quadrant location within the intersection.

Pedestal numbers should be made available to the geotechnical drilling Contractor. Include pedestal numbers in the boring label if they are available. If they are not available, ensure the boring labels can be cross-referenced to corresponding pedestal numbers or pedestal locations.

For each boring, submit a legible (hand written or typed) boring log signed and sealed by a licensed Geologist or Professional Engineer registered in North Carolina. Include on each boring the SPT blow counts and N-values at each depth, depth of the boring, and a general description of the soil types encountered.

U-4405

TS-114

Cumberland County

Borings that can't be easily related to their specific pedestal location will be returned to the contractor for clarification, or if approved by the Engineer, the foundation may be designed using the worst-case soil condition obtained as part of this project.

### 15.3. MEASUREMENT AND PAYMENT

*Soil test for DMS foundation* will be measured and paid as the actual number of Soil Tests with SPT borings drilled, furnished and accepted.

Payment will be made under:

Soil Test for DMS Foundation..... Each

## 16. FOUNDATIONS AND ANCHOR ROD ASSEMBLIES FOR METAL POLES

### 16.1. DESCRIPTION

Foundations for metal poles include foundations for signals, cameras, overhead and dynamic message signs (DMS) and high mount and low-level light standards supported by metal poles or upright trusses. Foundations consist of footings with pedestals and drilled piers with or without grade beams or wings. Anchor rod assemblies consist of anchor rods (also called anchor bolts) with nuts and washers on the exposed ends of rods and nuts and a plate or washers on the other ends of rods embedded in the foundation.

Construct concrete foundations with the required resistances and dimensions and install anchor rod assemblies in accordance with the contract and accepted submittals. Construct drilled piers consisting of cast-in-place reinforced concrete cylindrical sections in excavated holes. Provide temporary casings or polymer slurry as needed to stabilize drilled pier excavations. Use a prequalified Drilled Pier Contractor to construct drilled piers for steel pedestals. Define "excavation" and "hole" as a drilled pier excavation and "pier" as a drilled pier.

This provision does not apply to materials and anchor rod assemblies for standard foundations for low level light standards. See Section 1405 of the *Standard Specifications* and Standard Drawing No. 1405.01 of the *2012 Roadway Standard Drawings* for materials and anchor rod assemblies for standard foundations. For construction of standard foundations for low level light standards, standard foundations are considered footings in this provision.

This provision does not apply to foundations for signal pedestals; see Section 1743 of the *Standard Specifications* and Standard Drawing No. 1743.01 of the *2012 Roadway Standard Drawings*.

### 16.2. MATERIALS

Refer to the 2012 Standard Specifications.

Item	Section
Conduit	1091-3
Grout, Nonshrink	1003
Polymer Slurry	411-2(B)
Portland Cement Concrete	1000
Reinforcing Steel	1070

**U-4405****TS-115****Cumberland County**

Rollers and Chairs	411-2(C)
Temporary Casings	411-2(A)

Provide Type 3 material certifications in accordance with Article 106-3 of the *2018 Standard Specifications* for conduit, rollers, chairs, and anchor rod assemblies. Store steel materials on blocking at least 12" above the ground and protect it at all times from damage; and when placing in the work make sure it is free from dirt, dust, loose mill scale, loose rust, paint, oil, or other foreign materials. Load, transport, unload and store foundation and anchor rod assembly materials so materials are kept clean and free of damage. Damaged or deformed materials will be rejected.

Use conduit type in accordance with the contract. Use Class A concrete for footings and pedestals, Class Drilled Pier concrete for drilled piers and Class AA concrete for grade beams and wings including portions of drilled piers above bottom of wings elevations. Corrugated temporary casings may be accepted at the discretion of the Engineer. A list of approved polymer slurry products is available from:

[www.ncdot.org/doh/preconstruct/highway/geotech/leftmenu/Polymer.html](http://www.ncdot.org/doh/preconstruct/highway/geotech/leftmenu/Polymer.html)

Provide anchor rod assemblies in accordance with the contract consisting of the following:

- A. Straight anchor rods,
- B. Heavy hex top and leveling nuts and flat washers on exposed ends of rods, and
- C. Nuts and either flat plates or washers on the other ends of anchor rods embedded in foundations.

Do not use lock washers. Use steel anchor rods, nuts and washers that meet ASTM F1554 for Grade 55 rods and Grade A nuts. Use steel plates and washers embedded in concrete with a nominal thickness of at least 1/4". Galvanize anchor rods and exposed nuts and washers in accordance with Article 1076-4 of the *2018 Standard Specifications*. It is not necessary to galvanize nuts, plates and washers embedded in concrete.

### **16.3. CONSTRUCTION METHODS**

Install the required size and number of conduits in foundations in accordance with the Project Plans and accepted submittals. Construct top of piers, footings, pedestals, grade beams and wings flat, level and within 1" of elevations shown in the Project Plans or approved by the Engineer. Provide an Ordinary Surface finish in accordance with Subarticle 825-6(B) of the *2018 Standard Specifications* for portions of foundations exposed above finished grade. Do not remove anchor bolt templates or pedestal or grade beam forms or erect metal poles or upright trusses onto foundations until concrete attains a compressive strength of at least 3,000 psi.

#### **A. Drilled Piers**

Before starting drilled pier construction, hold a predrill meeting to discuss the installation, monitoring and inspection of the drilled piers. Schedule this meeting after the Drilled Pier Contractor has mobilized to the site. The Resident or Division Traffic Engineer, Contractor and Drilled Pier Contractor Superintendent will attend this predrill meeting.

Do not excavate holes, install piles, or allow equipment wheel loads or vibrations within 20 ft of completed piers until 16 hours after Drilled Pier concrete reaches initial set.

**U-4405****TS-116****Cumberland County**

Check for correct drilled pier alignment and location before beginning drilling. Check plumbness of holes frequently during drilling.

Construct drilled piers with the minimum required diameters shown in the foundation design plans. Install piers with tip elevations no higher than shown in the foundation design plans or approved by the Engineer.

Excavate holes with equipment of the sizes required to construct drilled piers. Depending on the subsurface conditions encountered, drilling through rock and boulders may be required. Do not use blasting for drilled pier excavations.

Contain and dispose of drilling spoils and waste concrete as directed and in accordance with Section 802 of the *Standard Specifications*. Drilling spoils consist of all materials and fluids removed from excavations.

If unstable, caving, or sloughing materials are anticipated or encountered, stabilize holes with temporary casings and/or polymer slurry. Do not use telescoping temporary casings. If it becomes necessary to replace a temporary casing during drilling, backfill the excavation, insert a larger casing around the casing to be replaced or stabilize the excavation with polymer slurry before removing the temporary casing.

If temporary casings become stuck or the Contractor proposes leaving casings in place, temporary casings should be installed against undisturbed material. Unless otherwise approved, do not leave temporary casings in place for mast arm poles and cantilever signs. The Engineer will determine if casings may remain in place. If the Contractor proposes leaving temporary casings in place, do not begin drilling until a casing installation method is approved.

Use polymer slurry and additives to stabilize holes in accordance with the slurry manufacturer's recommendations. Provide mixing water and equipment suitable for polymer slurry. Maintain polymer slurry at all times so slurry meets Table 411-3 of the *Standard Specifications* except for sand content.

Define a "sample set" as slurry samples collected from mid-height and within 2 ft of the bottom of holes. Take sample sets from excavations to test polymer slurry immediately after filling holes with slurry, at least every 4 hours thereafter and immediately before placing concrete. Do not place Drilled Pier concrete until both slurry samples from an excavation meet the required polymer slurry properties. If any slurry test results do not meet the requirements, the Engineer may suspend drilling until both samples from a sample set meet the required slurry properties.

Remove soft and loose material from bottom of holes using augers to the satisfaction of the Engineer. Assemble rebar cages and place cages and Drilled Pier concrete in accordance with Subarticle 411-4(E) of the *2018 Standard Specifications* except for the following:

- 1) Inspections for tip resistance and bottom cleanliness are not required,
- 2) Temporary casings may remain in place if approved, and
- 3) Concrete placement may be paused near the top of pier elevations for anchor rod assembly installation and conduit placement, or
- 4) If applicable, concrete placement may be stopped at bottom of grade beam or wings elevations for grade beam or wing construction.

If wet placement of concrete is anticipated or encountered, do not place Drilled Pier concrete until a concrete placement procedure is approved. If applicable, temporary casings and fluids may be removed when concrete placement is paused or stopped in accordance with the exceptions above provided holes are stable. Remove contaminated concrete from exposed Drilled Pier concrete after removing casings and fluids. If holes are unstable, do not remove temporary casings until a procedure for placing anchor rod assemblies and conduit or constructing grade beams or wings is approved.

Use collars to extend drilled piers above finished grade. Remove collars after Drilled Pier concrete sets and round top edges of piers.

If drilled piers are questionable, pile integrity testing (PIT) and further investigation may be required in accordance with Article 411-5 of the *Standard Specifications*. A drilled pier will be considered defective in accordance with Subarticle 411-5(D) of the *Standard Specifications* and drilled pier acceptance is based in part on the criteria in Article 411-6 of the *Standard Specifications* except for the top of pier tolerances in Subarticle 411-6(C) of the *Standard Specifications*.

If a drilled pier is under further investigation, do not grout core holes, backfill around the pier, or perform any work on the drilled pier until the Engineer accepts the pier. If the drilled pier is accepted, dewater and grout core holes and backfill around the pier with approved material to finished grade. If the Engineer determines a pier is unacceptable, remediation is required in accordance with Article 411-6 of the *2018 Standard Specifications*. No extension of completion date or time will be allowed for remediation of unacceptable drilled piers or post repair testing.

Permanently embed a plate in or mark top of piers with the pier diameter and depth, size and number of vertical reinforcing bars and the minimum compressive strength of the concrete mix at 28 days.

### **B. Footings, Pedestals, Grade Beams, and Wings**

Excavate as necessary for footings, grade beams and wings in accordance with the foundation design plans, accepted submittals, and Section 410 of the *Standard Specifications*. If unstable, caving, or sloughing materials are anticipated or encountered, shore foundation excavations as needed with an approved method. Notify the Engineer when foundation excavation is complete. Do not place concrete or reinforcing steel until excavation dimensions and foundation material are approved.

Construct cast-in-place reinforced concrete footings, pedestals, grade beams and wings with the dimensions shown in the foundation design plans and in accordance with Section 825 of the *2018 Standard Specifications*. Use forms to construct portions of pedestals and grade beams protruding above finished grade. Provide a chamfer with a 3/4" horizontal width for pedestal and grade beam edges exposed above finished grade. Backfill and fill in accordance with Article 410-8 of the *Standard Specifications*. Proper compaction around footings and wings is critical for foundations to resist uplift and torsion forces. Place concrete against undisturbed soil and do not use forms for standard foundations for low level light standards.

### **C. Anchor Rod Assemblies**

Size anchor rods for design and the required projection above top of foundations. Determine required anchor rod projections from nut, washer and base plate thicknesses, the protrusion of 3 to 5 anchor rod threads above top nuts after tightening and the distance of one nut thickness between top of foundations and bottom of leveling nuts.

**U-4405****TS-118****Cumberland County**

Protect anchor rod threads from damage during storage and installation of anchor rod assemblies. Before placing anchor rods in foundations, turn nuts onto and off rods past leveling nut locations. Turn nuts with the effort of one workman using an ordinary wrench without a cheater bar. Report any thread damage to the Engineer that requires 1 extra effort to turn nuts.

Arrange anchor rods symmetrically about center of base plate locations as shown in the foundation design plans. Set anchor rod elevations based on required projections above top of foundations. Securely brace and hold rods in the correct position, orientation, and alignment with a steel template. Do not weld to reinforcing steel, temporary casings or anchor rods.

Install top and leveling (bottom) nuts, washers, and the base plate for each anchor rod assembly in accordance with the following procedure:

1. Turn leveling nuts onto anchor rods to a distance of one nut thickness between the top of foundation and bottom of leveling nuts. Place washers over anchor rods on top of leveling nuts.
2. Determine if nuts are level using a flat rigid template on top of washers. If necessary, lower leveling nuts to level the template in all directions or if applicable, lower nuts to tilt the template so the metal pole or upright truss will lean as shown in the foundation design plans. If leveling nuts and washers are not in full contact with the template, replace washers with galvanized beveled washers.
3. Verify the distance between the foundation and leveling nuts is no more than one nut thickness.
4. Place base plate with metal pole or upright truss over anchor rods on top of washers. High mount luminaires may be attached before erecting metal poles but do not attach cables, mast arms or trusses to metal poles or upright trusses at this time.
5. Place washers over anchor rods on top of base plate. Lubricate top nut bearing surfaces and exposed anchor rod threads above washers with beeswax, paraffin, or other approved lubricant.
6. Turn top nuts onto anchor rods. If nuts are not in full contact with washers or washers are not in full contact with the base plate, replace washers with galvanized beveled washers.
7. Tighten top nuts to snug-tight with the full effort of one workman using a 12" wrench. Do not tighten any nut all at once. Turn top nuts in increments. Follow a star pattern cycling through each nut at least twice.
8. Repeat (7) for leveling nuts.
9. Replace washers above and below the base plate with galvanized beveled washers if the slope of any base plate face exceeds 1:20 (5%), any washer is not in firm contact with the base plate or any nut is not in firm contact with a washer. If any washers are replaced, repeat (7) and (8).
10. With top and leveling nuts snug-tight, mark each top nut on a corner at the intersection of 2 flats and a corresponding reference mark on the base plate. Mark top nuts and base plate with ink or paint that is not water-soluble. Use the turn-of-nut method for pretensioning. Do not pretension any nut all at once. Turn top nuts in increments for a total of one flat (1/6 revolution) for anchor rod diameters greater than 1 1/2" and 2 flats

U-4405

TS-119

Cumberland County

(1/3 revolution) for anchor rod diameters 1 1/2" or less. Follow 1 a star pattern 2 cycling through each top nut at least twice.

11. Ensure nuts, washers and base plate are in firm contact with each other for each anchor rod. Cables, mast arms and trusses may now be attached to metal poles and upright trusses.
12. Between 4 and 14 days after pretensioning top nuts, use a torque wrench calibrated within the last 12 months to check nuts in the presence of the Engineer. Completely erect mast arm poles and cantilever signs and attach any hardware before checking top nuts for these structures. Check that top nuts meet the following torque requirements:

<b>TORQUE REQUIREMENTS</b>	
<b>Anchor Rod Diameter, inch</b>	<b>Requirement, ft-lb</b>
7/8	180
1	270
1-1/8	380
1-1/4	420
≥ 1-1/2	600

If necessary, retighten top nuts in the presence of the Engineer with a calibrated torque wrench to within ± 10 ft-lb of the required torque. Do not over tighten top nuts.

13. Do not grout under base plate.

#### **16.4. MEASUREMENT AND PAYMENT**

Foundations and anchor rod assemblies for metal poles and upright trusses will be measured and paid for elsewhere in the contract.

No payment will be made for temporary casings that remain in drilled pier excavations. No payment will be made for PIT. No payment will be made for further investigation of defective piers. Further investigation of piers that are not defective will be paid as extra work in accordance with Article 104-7 of the *2018 Standard Specifications*. No payment will be made for remediation of unacceptable drilled piers or post repair testing.

### **17. DYNAMIC MESSAGE SIGN FOUNDATIONS**

#### **17.1. DESCRIPTION**

Sign foundations include foundations for overhead and dynamic message signs (DMS) supported by metal poles or upright trusses. Sign foundations consist of footings with pedestals or drilled piers with or without grade beams or wings, conduit and anchor rod assemblies. Construct sign foundations in accordance with the contract and accepted submittals. Define "cantilever sign" as an overhead cantilever sign support in accordance with Figure 1-1 of the *AASHTO Standard Specifications for Structural Supports for Highway Signs, Luminaries, and Traffic Signals*, 5<sup>th</sup> Edition, 2009, including the latest interim specifications.

## 17.2. MATERIALS

Use sign foundation materials that meet the Foundations and Anchor Rod Assemblies for Metal Poles provision.

### A. Assumed Subsurface Conditions

Assume the following soil parameters and groundwater elevation for sign foundations unless these subsurface conditions are not applicable to sign locations:

- A. Unit weight ( $\gamma$ ) = 120 lb/cuff,
- B. Friction angle ( $c_j$ ) = 30°F,
- C. Cohesion ( $c$ ) = 0 lb/sf, and
- D. Groundwater 7 ft below finished grade.

A subsurface investigation is required if the Engineer determines these assumed subsurface conditions do not apply to a sign location and the sign cannot be moved. Subsurface conditions requiring a subsurface investigation include but are not limited to weathered or hard rock, boulders, very soft or loose soil, muck or shallow groundwater. No extension of completion date or time will be allowed for subsurface investigations.

### B. Subsurface Investigations

Use a prequalified geotechnical consultant to perform one standard penetration test

(SPT) boring in accordance with ASTM D1586 at each sign location requiring a subsurface investigation. Rough grade sign locations to within 2 ft of finished grade before beginning drilling. Drill borings to 2 drilled pier diameters below anticipated pier tip elevations or refusal, whichever is higher.

Use the computer software gINT version 8.0 or later manufactured by Bentley Systems, Inc. with the current NCDOT gINT library and data template to produce SPT boring logs. Provide boring logs sealed by a geologist or engineer licensed in the state of North Carolina.

### C. Sign Foundation Designs

Design sign foundations for the wind zone and clearances shown in the foundation design plans and the slope of finished grade at each sign location. Use the assumed soil parameters and groundwater elevation above for sign foundation designs unless a subsurface investigation is required. For sign locations requiring a subsurface investigation, design sign foundations for the subsurface conditions at each sign location. Design footings, pedestals, drilled piers, grade beams and wings in accordance with the 5th Edition of the *AASHTO Standard Specifications for Structural Supports for Highway Signs, Luminaries, and Traffic Signals*, 5th Edition, 2009, including the latest interim specifications. In some instances, conflicts with drainage structures may dictate sign foundation types.

Design footings in accordance with Section 4.4 of the *AASHTO Standard Specifications for Highway Bridges*. Do not use an allowable bearing pressure of more than 3,000 lb/sf for footings.

Design drilled piers for side resistance only in accordance with Section 4.6 of the *AASHTO Standard Specifications for Highway Bridges* except reduce ultimate side resistance by 25% for uplift. Use the computer software LPILE version 5.0 or later manufactured by Ensoft, Inc. to analyze drilled piers. Provide drilled pier designs with a horizontal deflection of less than 1" at top of piers.



**U-4405**

**TS-121**

**Cumberland County**

For cantilever signs with single drilled pier foundations supporting metal poles, use wings to resist torsion forces. Provide drilled pier designs with a factor of safety of at least 2.0 for torsion.

For drilled pier sign foundations supporting upright trusses, use dual drilled piers connected with a grade beam having a moment of inertia approximately equal to that of either pier. The Broms' method is acceptable to analyze drilled piers with grade beams instead of LPILE. Use a safety factor of at least 3.5 for the Broms' design method in accordance with C13.6.1.1 of the *AASHTO Standard Specifications for Structural Supports for Highway Signs, Luminaries, and Traffic Signals*, 5th Edition, 2009, including the latest interim specifications.

*Specifications for Structural Supports for Highway Signs, Luminaries, and Traffic Signals*, 5th Edition, 2009, including the latest interim specifications.

Submit boring logs, if any, working drawings and design calculations for acceptance in accordance with Article 105-2 of the *2018 Standard Specifications*. Submit working drawings showing plan views, required foundation dimensions and elevations and typical sections with reinforcement, conduit, and anchor rod assembly details. Include all boring logs, design calculations and LPILE output for sign foundation design submittals. Have sign foundations designed, detailed, and sealed by an engineer licensed in the state of North Carolina.

**17.3. CONSTRUCTION METHODS**

Construct footings, pedestals, drilled piers, grade beams and wings and install anchor rod assemblies for sign foundations in accordance with the Foundations and Anchor Rod Assemblies for Metal Poles provision.

**17.4. MEASUREMENT AND PAYMENT**

*DMS foundation* will be measured and paid in cubic yards of concrete for footings, pedestals, drilled piers, grade beams and wings shown on the accepted submittals. The contract unit price for *DMS foundation* will be full compensation for providing labor, tools, equipment, and foundation materials, stabilizing, or shoring excavations and supplying concrete, reinforcing steel, conduit, anchor rod assemblies and any incidentals necessary to construct sign foundations. Subsurface investigations required by the Engineer will be paid as extra work in accordance with Article 104-7 of the *2018 Standard Specifications*.

Payment will be made under:

<b>Pay Item</b>	<b>Pay Unit</b>
DMS Foundation .....	Cubic Yards