

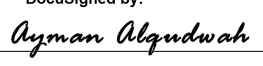

**This electronic collection of documents is provided
for the convenience of the user
and is Not a Certified Document –**

**The documents contained herein were originally issued
and sealed by the individuals whose names and license
numbers appear on each page, on the dates appearing
with their signature on that page.**

**This file or an individual page
shall not be considered a certified document.**

TIP NO. R-2814C	SHEET NO. PMP-1
APPROVED:  DATE: 4/26/2018	
SEAL 	
DOCUMENT NOT CONSIDERED FINAL UNLESS ALL SIGNATURES COMPLETED	

**STATE OF NORTH CAROLINA
DEPARTMENT OF TRANSPORTATION**

**PAVEMENT MARKING PLAN
WAKE & FRANKLIN COUNTY**

LOCATION: US 401 FROM NC 96 TO NORTH OF SR 1103(FLAT ROCK CHURCH RD/CLIFTON POND RD)

T.I.P.: R-2814C

CONTRACT: C204105

ROADWAY STANDARD DRAWING

THE FOLLOWING ROADWAY STANDARDS AS APPEAR IN "ROADWAY STANDARD DRAWINGS" - PROJECT SERVICES UNIT - N.C. DEPARTMENT OF TRANSPORTATION - RALEIGH, N.C., DATED JANUARY 2018 ARE APPLICABLE TO THIS PROJECT AND BY REFERENCE HEREBY ARE CONSIDERED A PART OF THESE PLANS:

STD. NO.	TITLE
1205.01	PAVEMENT MARKINGS - LINE TYPES AND OFFSETS
1205.02	PAVEMENT MARKINGS - TWO-LANE AND MULTILANE ROADWAYS
1205.03	PAVEMENT MARKINGS - EXIT AND ENTRANCE RAMP
1205.04	PAVEMENT MARKINGS - INTERSECTIONS
1205.05	PAVEMENT MARKINGS - TURN LANES
1205.08	PAVEMENT MARKINGS - SYMBOLS AND WORD MESSAGES
1205.09	PAVEMENT MARKINGS - PAINTED ISLANDS
1205.13	PAVEMENT MARKINGS - LANE REDUCTIONS
1205.15	PAVEMENT MARKINGS - SUPERSTREETS
1250.01	RAISED PAVEMENT MARKERS - INSTALLATION SPACING
1251.01	RAISED PAVEMENT MARKERS - PERMANENT AND TEMPORARY
1253.01	RAISED PAVEMENT MARKERS - SNOWPLOWABLE
1261.01	GUARDRAIL AND BARRIER DELINEATORS - INSTALLATION SPACING
1261.02	GUARDRAIL AND BARRIER DELINEATORS - TYPES AND MOUNTING
1262.01	GUARDRAIL END DELINEATION

GENERAL NOTES

THE FOLLOWING GENERAL NOTES APPLY AT ALL TIMES FOR THE DURATION OF THE CONSTRUCTION PROJECT, EXCEPT WHEN OTHERWISE NOTED IN THE PLAN, OR DIRECTED BY THE ENGINEER.

- A) INSTALL PAVEMENT MARKINGS AND PAVEMENT MARKERS ON THE FINAL SURFACE AS FOLLOWS:

ROAD NAME	MARKING	MARKER
ALL	THERMOPLASTIC	SNOWPLOWABLE
- B) PLACE TWO APPLICATIONS OF PAINT PAVEMENT MARKINGS ON THE FINAL WEARING SURFACE. PLACE THE SECOND APPLICATION OF PAINT UPON SUFFICIENT DRYING TIME OF THE FIRST.
- C) TIE PROPOSED PAVEMENT MARKING LINES TO EXISTING PAVEMENT MARKING LINES.
- D) REMOVE/REPLACE ANY CONFLICTING/DAMAGED PAVEMENT MARKINGS AND MARKERS.
- E) PASSING ZONES WILL BE DETERMINED IN THE FIELD AND MUST BE APPROVED BY THE ENGINEER.
- F) STOP BAR LOCATION AT NON-SIGNALIZED INTERSECTIONS MAY BE ADJUSTED AS DIRECTED BY THE ENGINEER.
- G) UNLESS OTHERWISE SPECIFIED, HEATED-IN-PLACE THERMOPLASTIC MAY BE USED IN LIEU OF EXTRUDED THERMOPLASTIC FOR STOP BARS, SYMBOLS, CHARACTERS AND DIAGONALS. IF HEATED-IN-PLACE IS USED, IT SHALL BE PAID FOR USING THE EXTRUDED THERMOPLASTIC PAY ITEM.
- H) SEE ROADWAY PLANS FOR ALTERNATE CURB RAMP DESIGNS WHEN INDICATED ON PAVEMENT MARKING DETAIL SHEETS.

INDEX

SHEET NO.	DESCRIPTION
PMP-1	PAVEMENT MARKING PLAN TITLE
PMP-2	PAVEMENT MARKING SCHEDULE
PMP-3-20	PAVEMENT MARKING DETAIL

PLAN PREPARED BY: N.C.D.O.T. SIGNING AND DELINEATION UNIT

AYMAN ALQUDWAH, P.E. SIGNING & DELINEATION REGIONAL ENGINEER

STACEY JOHNS SIGNING & DELINEATION PROJECT DESIGN ENGINEER

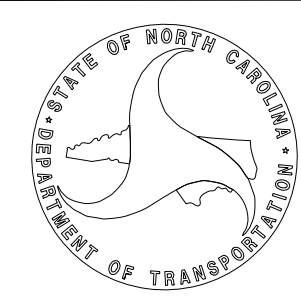

TIP NO.	SHEET NO.
R-2814C	PMP-2
APPROVED:	DocuSigned by: <i>Ayman Alqudwah</i> F32AC5CAF96472
DATE:	4/26/2018
SEAL	
DOCUMENT NOT CONSIDERED FINAL UNLESS ALL SIGNATURES COMPLETED	

PAVEMENT MARKING SCHEDULE

	THERMOPLASTIC(24", 120 MILS)
T2	WHITE STOPBAR
	THERMOPLASTIC(4", 90 MILS)
TA	WHITE EDGELINE
TB	YELLOW EDGELINE
	THERMOPLASTIC(4", 120 MILS)
T8	2 FT. - 6 FT./SP WHITE MINISKIP
T9	2 FT. - 6 FT./SP YELLOW MINISKIP
TC	10 FT. WHITE SKIP
TD	3 FT. - 9 FT./SP WHITE MINISKIP
TE	WHITE SOLID LANE LINE
TF	10 FT. YELLOW SKIP
TH	YELLOW SINGLE CENTER
TI	YELLOW DOUBLE CENTER
	THERMOPLASTIC(8", 90 MILS)
TN	WHITE GORELINE
TO	WHITE DIAGONALS
TP	YELLOW DIAGONALS
	THERMOPLASTIC MARKING CHARACTER (120 MILS)
UI	ALPHANUMERIC CHAR.
	THERMOPLASTIC MARKING SYMBOLS (90 MILS)
UA	LEFT TURN ARROW
UB	RIGHT TURN ARROW
UN	24" YIELD LINE TRIANGLE
UP	MERGE ARROW
UT	U-TURN ARROW
	SNOWPLOWABLE PAVEMENT MARKERS
ME	YELLOW & YELLOW
MF	CRYSTAL & RED

04/24/18
 N:\TIPPROJECTS\R-2814c\Traffic\Signing\CADD\PMR\R2814C_PMP_L1.dgn
 User:stjohns

PAVEMENT MARKING SCHEDULE

APPROVED: *Ayman Aljoudah*
F32AC5CAF985472
 DATE: 4/26/2018

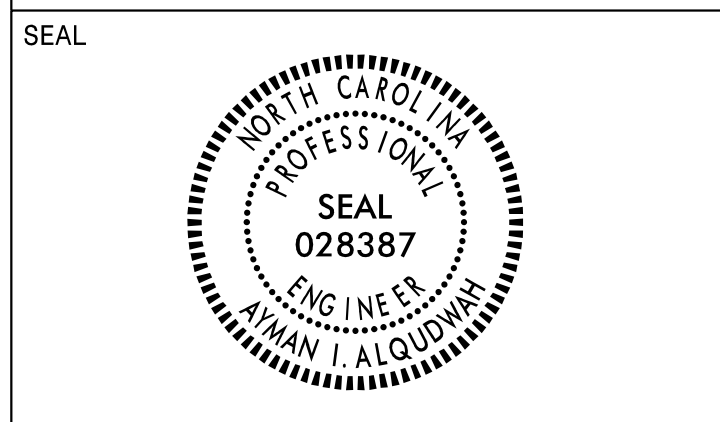

DOCUMENT NOT CONSIDERED FINAL
 UNLESS ALL SIGNATURES COMPLETED

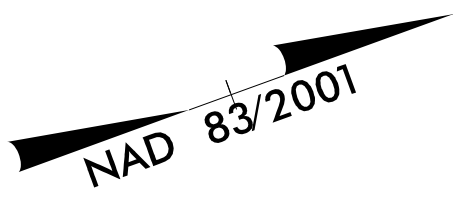

BEGIN PMP PROJECT R-2814C
 -L STA. 33+00 +/-
 TIE TO EXISTING

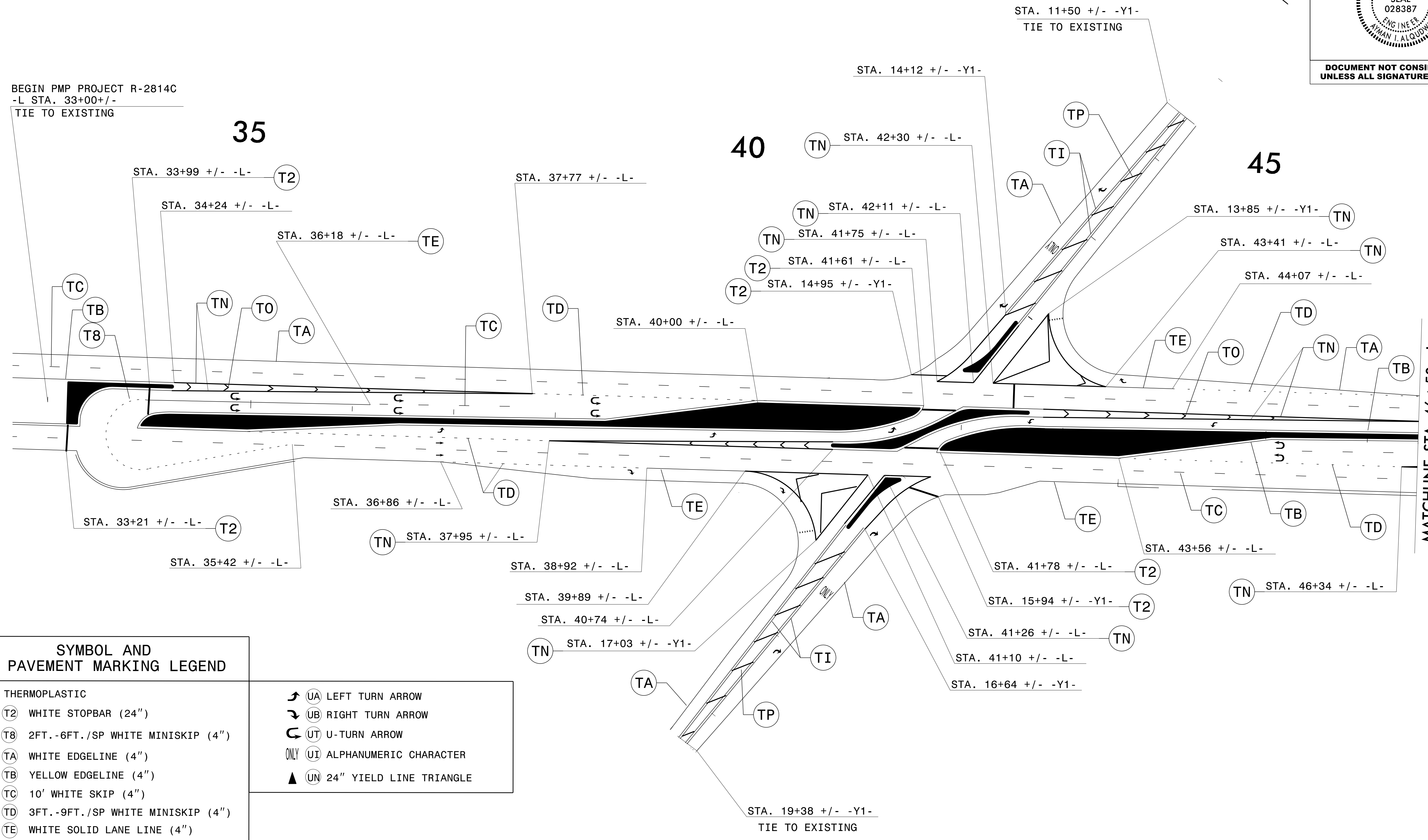

MATCHLINE STA. 46+50 -L-
 SEE SHEET PMP-4

SYMBOL AND PAVEMENT MARKING LEGEND

- THERMOPLASTIC**
- T2 WHITE STOPBAR (24")
 - T8 2FT.-6FT./SP WHITE MINISKIP (4")
 - TA WHITE EDGELINE (4")
 - TB YELLOW EDGELINE (4")
 - TC 10' WHITE SKIP (4")
 - TD 3FT.-9FT./SP WHITE MINISKIP (4")
 - TE WHITE SOLID LANE LINE (4")
 - TI YELLOW DOUBLE CENTER (4")
 - TN WHITE GORE LINE (8")
 - TO WHITE DIAGONAL (8")
 - TP YELLOW DIAGONAL (8")

- ↙ UA LEFT TURN ARROW
- ↘ UB RIGHT TURN ARROW
- ↻ UT U-TURN ARROW
- ONLY UI ALPHANUMERIC CHARACTER
- ▲ UN 24" YIELD LINE TRIANGLE

04/24/18
 N:\TIP\Projects-R\R2814C\Traffic\Signing\CADD\MP\R2814C_PMP_3.dgn
 Users\johns

PAVEMENT MARKING DETAIL

APPROVED: *Ayman Aljoudah*
F32AC5CAF985472
DATE: 4/26/2018

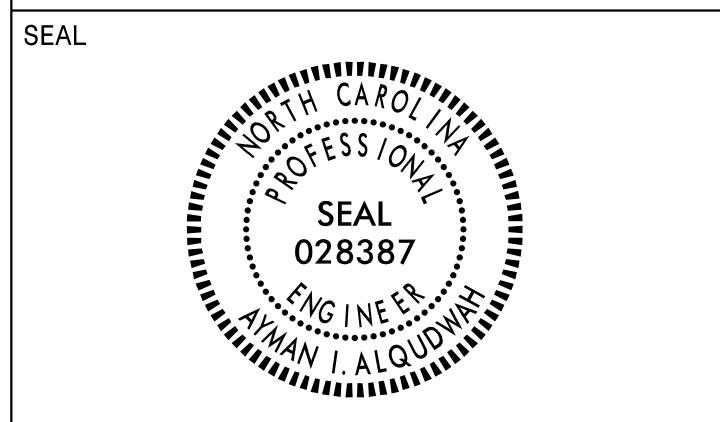

DOCUMENT NOT CONSIDERED FINAL
UNLESS ALL SIGNATURES COMPLETED

**SYMBOL AND
PAVEMENT MARKING LEGEND**

- THERMOPLASTIC
- (T2) WHITE STOPBAR (24")
 - (T8) 2FT.-6FT./SP WHITE MINISKIP (4")
 - (TA) WHITE EDGELINE (4")
 - (TB) YELLOW EDGELINE (4")
 - (TC) 10' WHITE SKIP (4")
 - (TD) 3FT.-9FT./SP WHITE MINISKIP (4")
 - (TE) WHITE SOLID LANE LINE (4")
 - (TN) WHITE GORE LINE (8")
 - (TO) WHITE DIAGONAL (8")

- (UA) LEFT TURN ARROW
- (UT) U-TURN ARROW

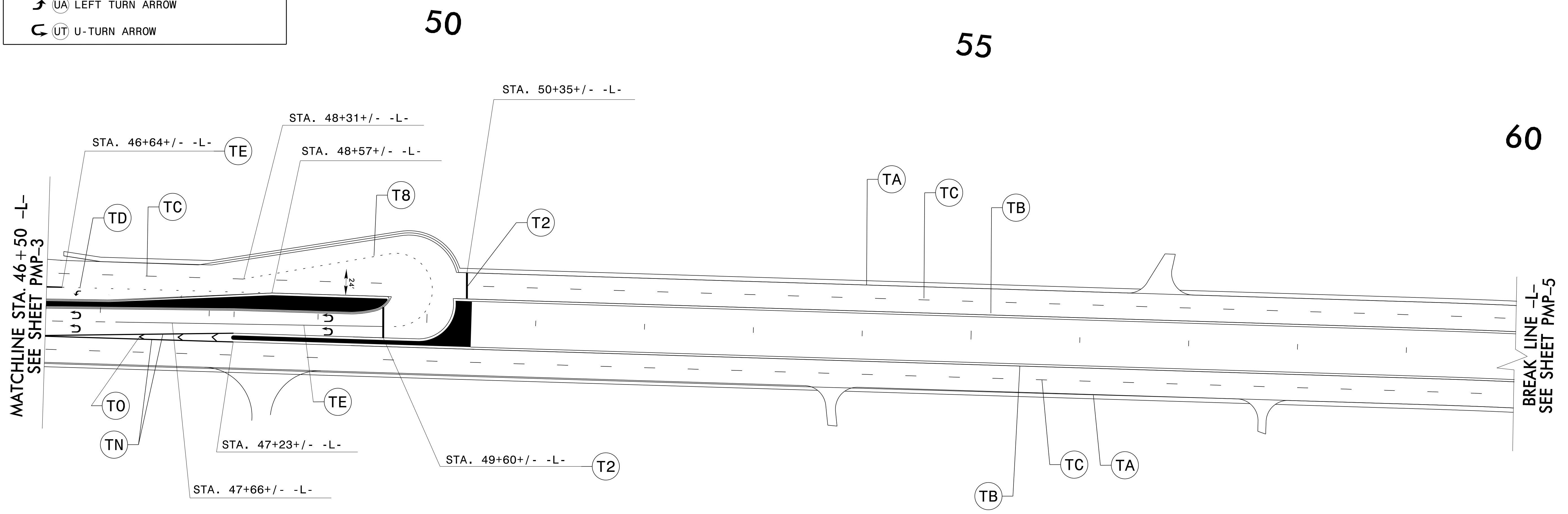
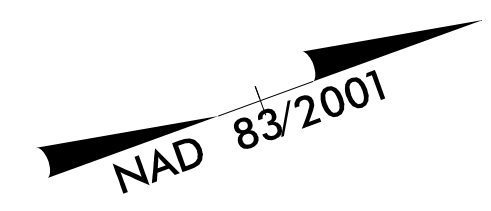

04/24/18
 N:\TIP-Projects-R\R2814c\Traffic\Signing\CADD\PMR\R2814C_PMP_4.dgn
 Users\johns

PAVEMENT MARKING DETAIL

APPROVED: *Ayman Alqudwah*
F32AC5CAF68472
 DATE: 4/26/2018

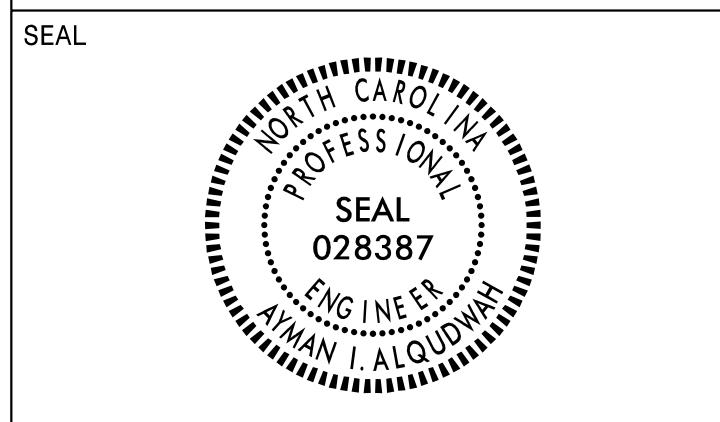

DOCUMENT NOT CONSIDERED FINAL UNLESS ALL SIGNATURES COMPLETED

SYMBOL AND PAVEMENT MARKING LEGEND	
THERMOPLASTIC	
(T2)	WHITE STOPBAR (24")
(T8)	2FT.-6FT./SP WHITE MINISKIP (4")
(T9)	2FT.-6FT./SP YELLOW MINISKIP (4")
(TA)	WHITE EDGELINE (4")
(TB)	YELLOW EDGELINE (4")
(TC)	10' WHITE SKIP (4")
(TD)	3FT.-9FT./SP WHITE MINISKIP (4")
(TE)	WHITE SOLID LANE LINE (4")
(TI)	YELLOW DOUBLE CENTER (4")
(TN)	WHITE GORE LINE (8")
(TO)	WHITE DIAGONAL (8")

↶ (UA)	LEFT TURN ARROW
↷ (UB)	RIGHT TURN ARROW
↻ (UT)	U-TURN ARROW
ONLY (UI)	ALPHANUMERIC CHARACTER
▲ (UN)	24" YIELD LINE TRIANGLE

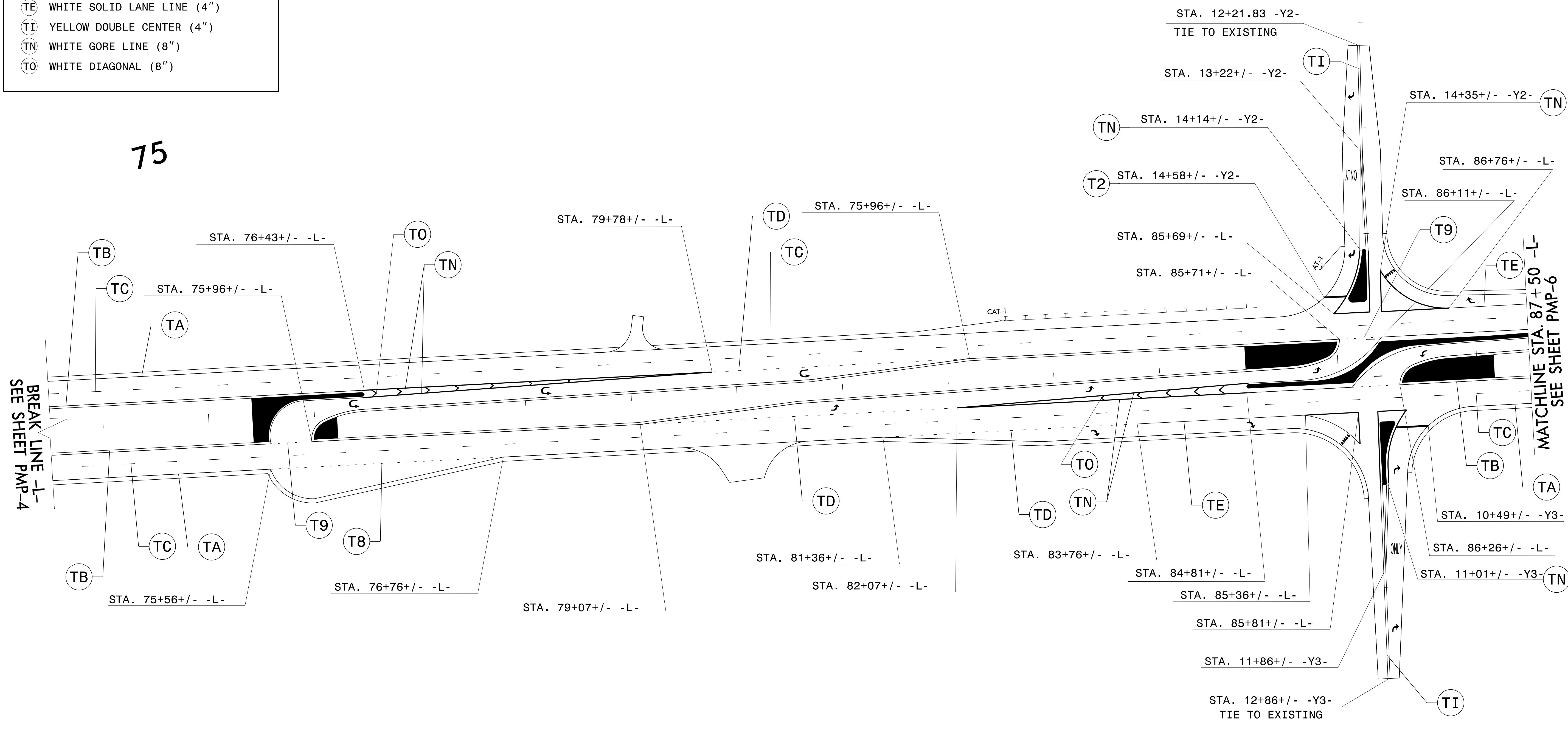
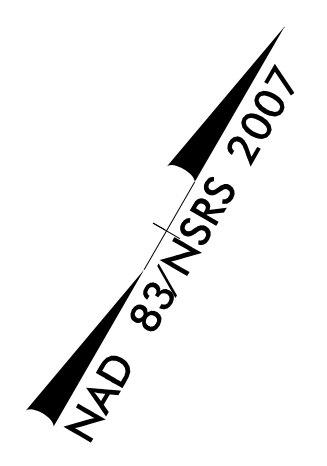

PAVEMENT MARKING DETAIL

04/24/18
 I:\TIP-Projects-R\R2814C-Traffic\Signing\CADD\PMR\R2814C_PMP_5.dgn
 Users\johns

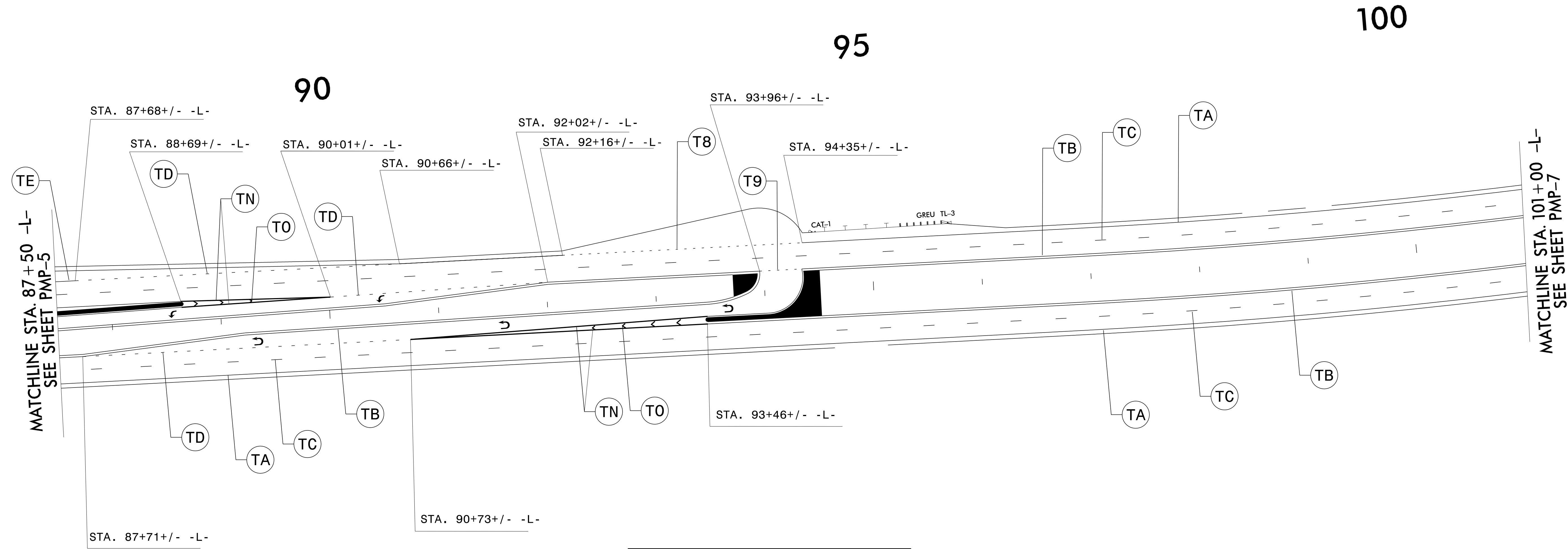
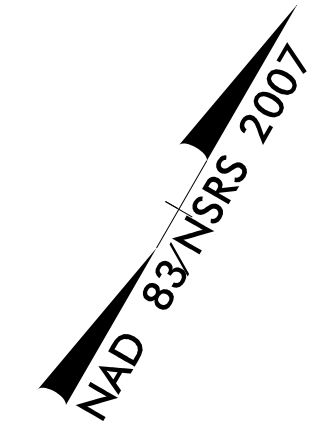

SYMBOL AND PAVEMENT MARKING LEGEND	
THERMOPLASTIC	
(T8)	2FT.-6FT./SP WHITE MINISKIP (4")
(T9)	2FT.-6FT./SP YELLOW MINISKIP (4")
(TA)	WHITE EDGELINE (4")
(TB)	YELLOW EDGELINE (4")
(TC)	10' WHITE SKIP (4")
(TD)	3FT.-9FT./SP WHITE MINISKIP (4")
(TE)	WHITE SOLID LANE LINE (4")
(TN)	WHITE GORE LINE (8")
(TO)	WHITE DIAGONAL (8")
(UA)	LEFT TURN ARROW
(UT)	U-TURN ARROW

PAVEMENT MARKING DETAIL

04/24/18
 N:\TIP-Projects-R\R2814C\Traffic\Signing\CADD\PMR\R2814C_PMP_6.dgn
 Users\johns

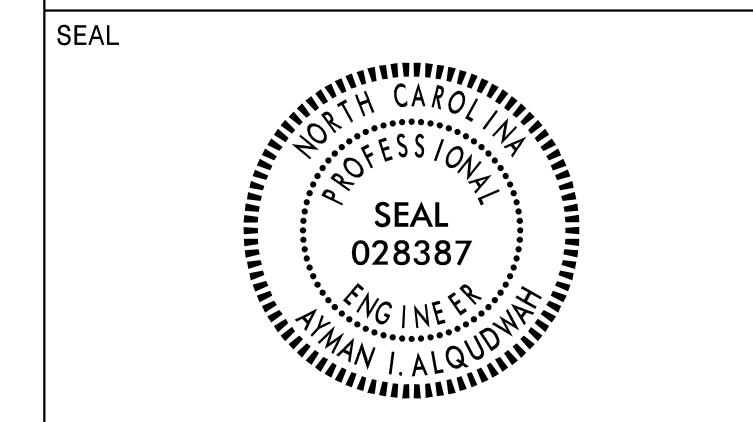

DOCUMENT NOT CONSIDERED FINAL
 UNLESS ALL SIGNATURES COMPLETED

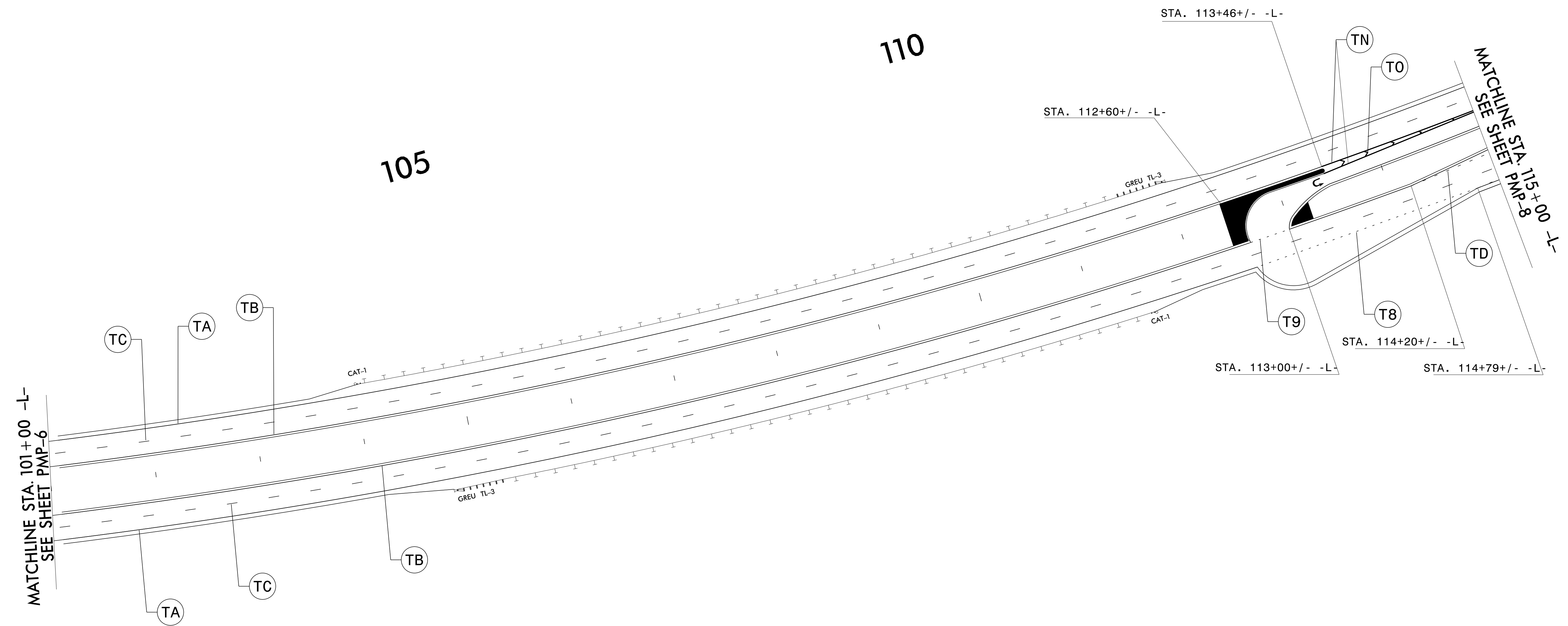
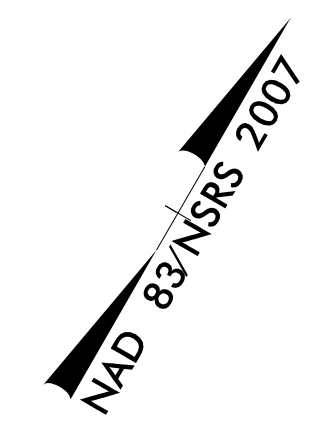

SYMBOL AND PAVEMENT MARKING LEGEND	
THERMOPLASTIC	
(T8)	2FT.-6FT./SP WHITE MINISKIP (4")
(T9)	2FT.-6FT./SP YELLOW MINISKIP (4")
(TA)	WHITE EDGELINE (4")
(TB)	YELLOW EDGELINE (4")
(TC)	10' WHITE SKIP (4")
(TD)	3FT.-9FT./SP WHITE MINISKIP (4")
(TN)	WHITE GORE LINE (8")
(TO)	WHITE DIAGONAL (8")
(UT)	U-TURN ARROW

PAVEMENT MARKING DETAIL

04/24/18
 N:\TIP-Projects-R\R2814C\Traffic\Signing\CADD\PMR\R2814C_PMP_7.dgn
 Users\johns

APPROVED: *Ayman Alqudwah*
F32AC5CAF685472
 DATE: 4/26/2018

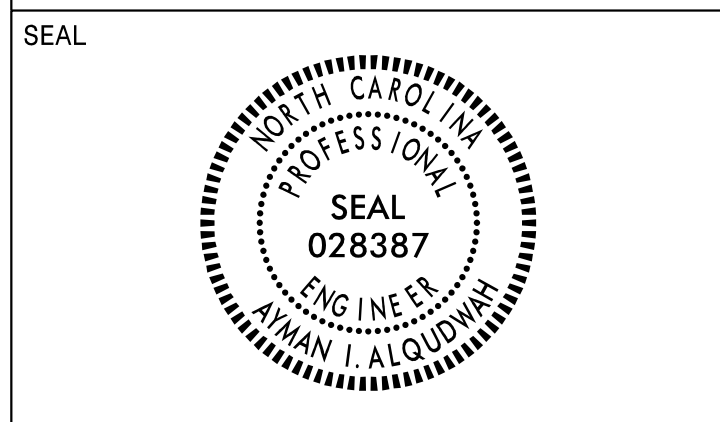

**DOCUMENT NOT CONSIDERED FINAL
 UNLESS ALL SIGNATURES COMPLETED**

SYMBOL AND PAVEMENT MARKING LEGEND

- THERMOPLASTIC**
- (T2) WHITE STOPBAR (24")
 - (T9) 2FT.-6FT./SP YELLOW MINISKIP (4")
 - (TA) WHITE EDGELINE (4")
 - (TB) YELLOW EDGELINE (4")
 - (TC) 10' WHITE SKIP (4")
 - (TD) 3FT.-9FT./SP WHITE MINISKIP (4")
 - (TE) WHITE SOLID LANE LINE (4")
 - (TI) YELLOW DOUBLE CENTER (4")
 - (TN) WHITE GORE LINE (8")
 - (TO) WHITE DIAGONAL (8")

- (UA) LEFT TURN ARROW
- (UB) RIGHT TURN ARROW
- (UT) U-TURN ARROW
- (UI) ALPHANUMERIC CHARACTER
- (UN) 24" YIELD LINE TRIANGLE

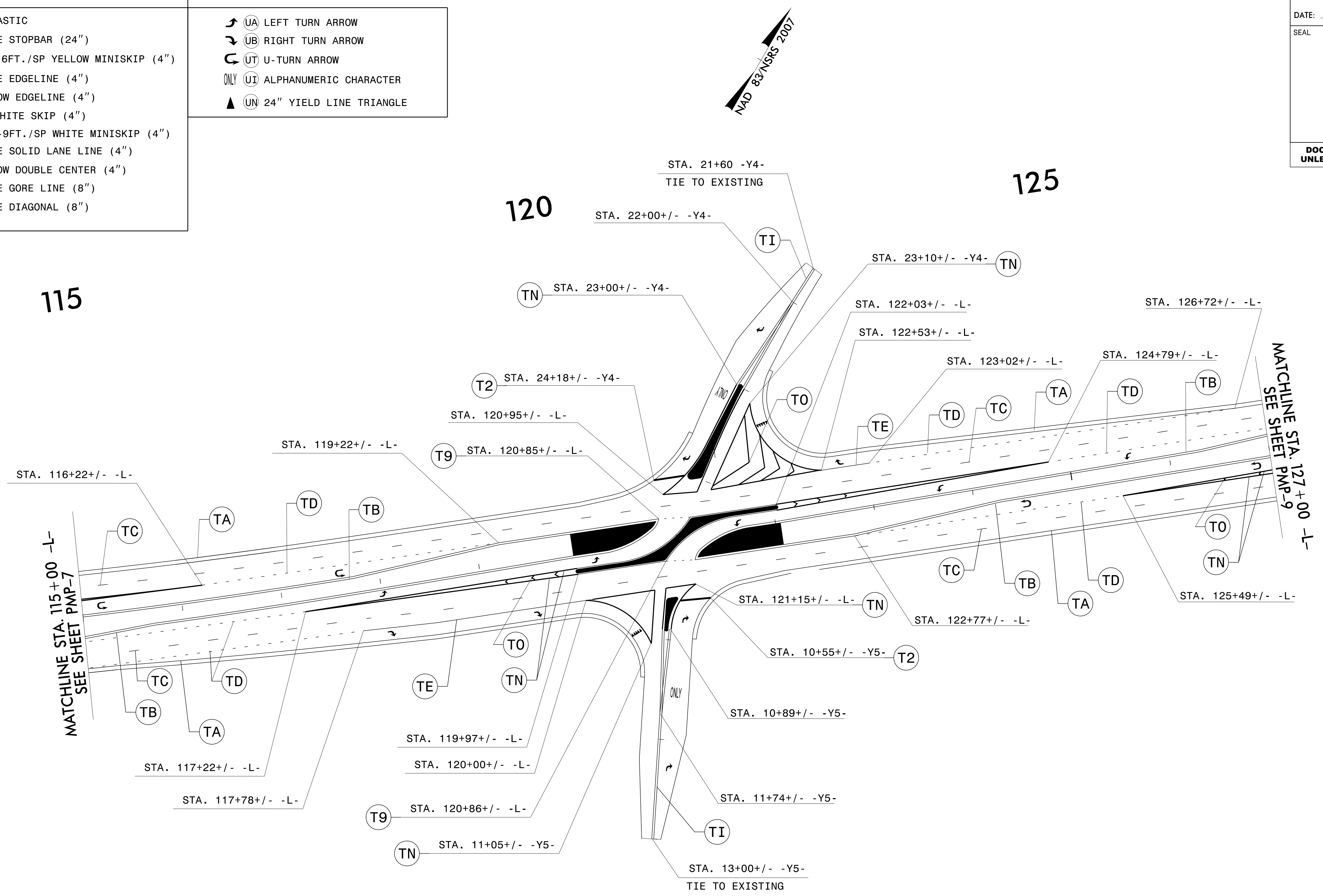

04/24/18
 N:\TIP-Projects-R\R2814c\Traffic\Signing\CADD\PMR\R2814C_PMP_8.dgn
 Users\johns

PAVEMENT MARKING DETAIL

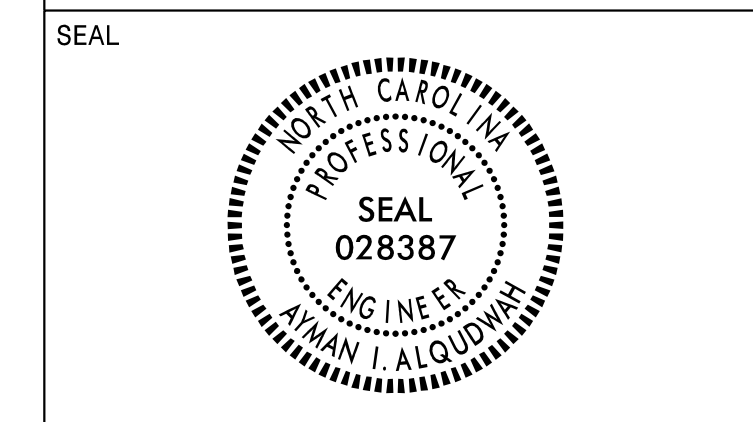

DOCUMENT NOT CONSIDERED FINAL
UNLESS ALL SIGNATURES COMPLETED

SYMBOL AND PAVEMENT MARKING LEGEND	
THERMOPLASTIC	
(T8)	2FT.-6FT./SP WHITE MINISKIP (4")
(T9)	2FT.-6FT./SP YELLOW MINISKIP (4")
(TA)	WHITE EDGELINE (4")
(TB)	YELLOW EDGELINE (4")
(TC)	10' WHITE SKIP (4")
(TD)	3FT.-9FT./SP WHITE MINISKIP (4")
(TN)	WHITE GORE LINE (8")
(TO)	WHITE DIAGONAL (8")
(UT)	U-TURN ARROW

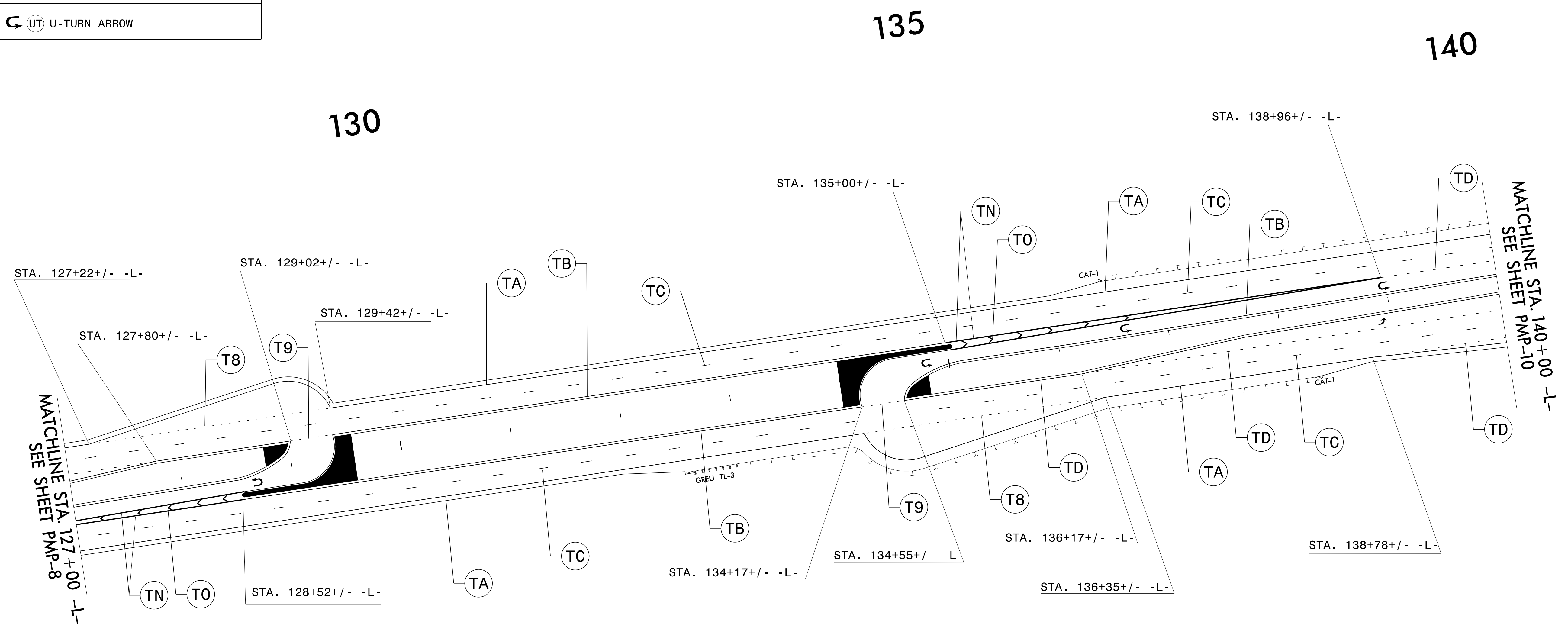
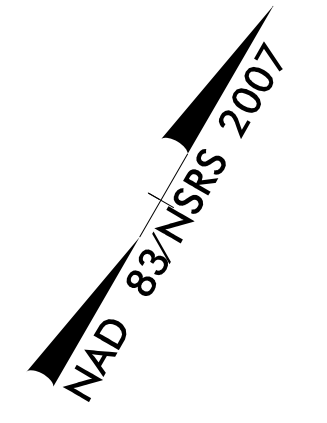

04/24/18
 N:\TIP-Projects-R\R2814c\Traffic\Signing\CADD\PMR\R2814C_PMP_9.dgn
 Users\johns

PAVEMENT MARKING DETAIL

APPROVED: *Ayman Alqudwah*
DocuSigned by:
 Ayman Alqudwah
 F32AC5CAF985472
 4/26/2018

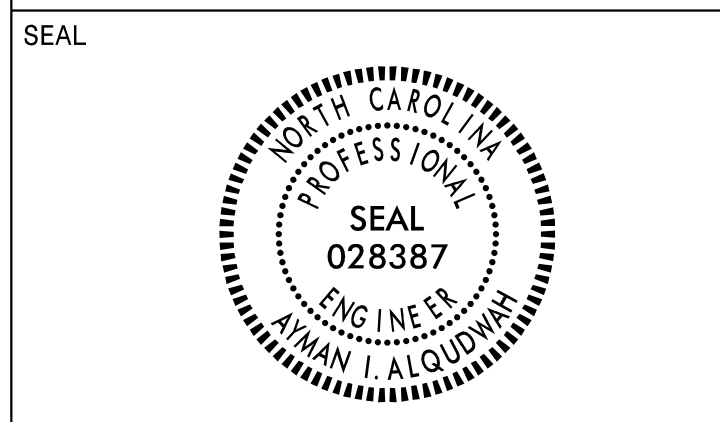

DOCUMENT NOT CONSIDERED FINAL
 UNLESS ALL SIGNATURES COMPLETED

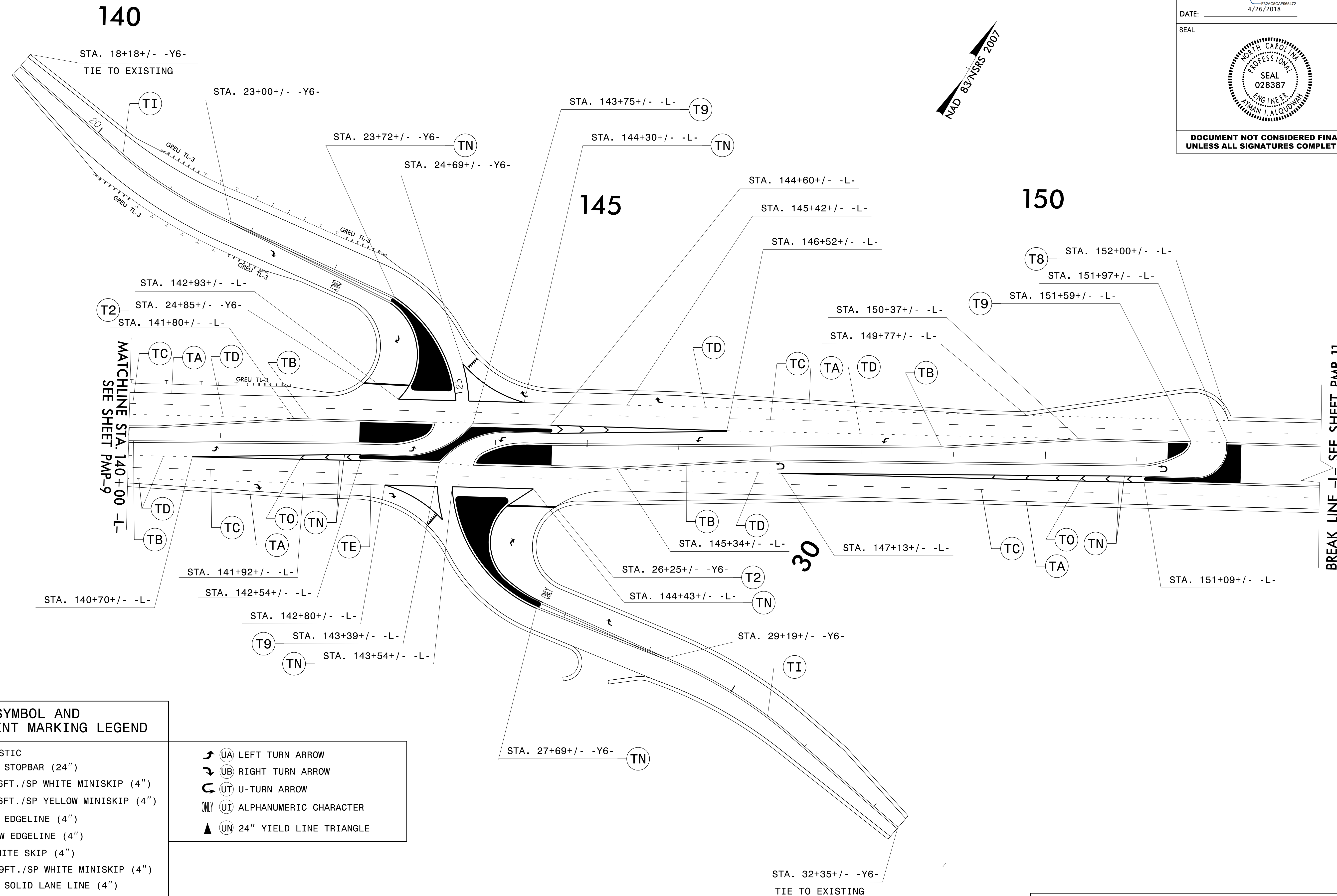
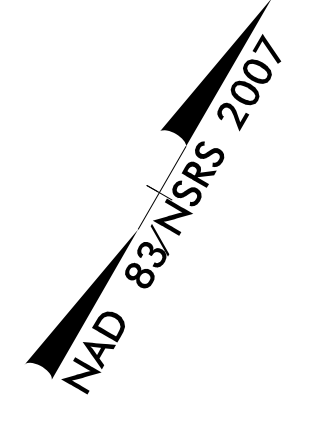

SYMBOL AND PAVEMENT MARKING LEGEND

THERMOPLASTIC	
T2	WHITE STOPBAR (24")
T8	2FT.-6FT./SP WHITE MINISKIP (4")
T9	2FT.-6FT./SP YELLOW MINISKIP (4")
TA	WHITE EDGELINE (4")
TB	YELLOW EDGELINE (4")
TC	10' WHITE SKIP (4")
TD	3FT.-9FT./SP WHITE MINISKIP (4")
TE	WHITE SOLID LANE LINE (4")
TI	YELLOW DOUBLE CENTER (4")
TN	WHITE GORE LINE (8")
TO	WHITE DIAGONAL (8")

UA	LEFT TURN ARROW
UB	RIGHT TURN ARROW
UT	U-TURN ARROW
ONLY	ALPHANUMERIC CHARACTER
UN	24" YIELD LINE TRIANGLE

PAVEMENT MARKING DETAIL

04/24/18
 N:\TIP\Projects-R\R2814c\Traffic\Signing\CADD\PM\R2814C_PMP_10.dgn
 Users\johns

APPROVED: *Ayman Alqudwah*
Professional Engineer
 F32425CAF985472
 4/26/2018



DOCUMENT NOT CONSIDERED FINAL
 UNLESS ALL SIGNATURES COMPLETED

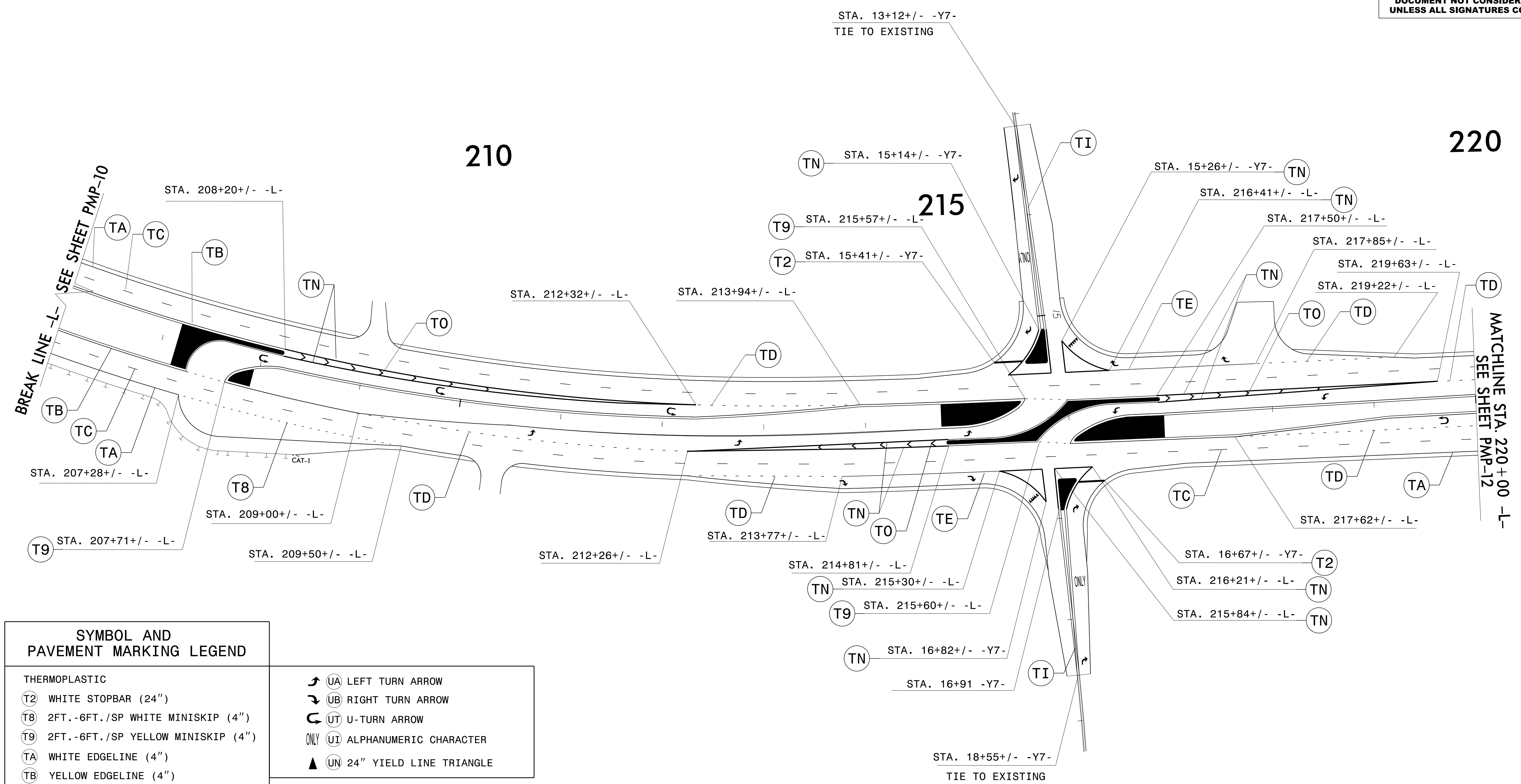
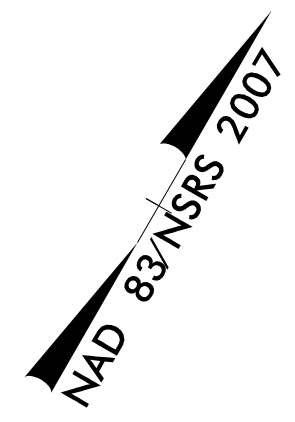

SYMBOL AND PAVEMENT MARKING LEGEND	
THERMOPLASTIC	
T2	WHITE STOPBAR (24")
T8	2FT.-6FT./SP WHITE MINISKIP (4")
T9	2FT.-6FT./SP YELLOW MINISKIP (4")
TA	WHITE EDGELINE (4")
TB	YELLOW EDGELINE (4")
TC	10' WHITE SKIP (4")
TD	3FT.-9FT./SP WHITE MINISKIP (4")
TE	WHITE SOLID LANE LINE (4")
TI	YELLOW DOUBLE CENTER (4")
TN	WHITE GORE LINE (8")
TO	WHITE DIAGONAL (8")

↙	UA	LEFT TURN ARROW
↘	UB	RIGHT TURN ARROW
↻	UT	U-TURN ARROW
ONLY	UI	ALPHANUMERIC CHARACTER
▲	UN	24" YIELD LINE TRIANGLE

PAVEMENT MARKING DETAIL

04/24/18
 N:\TIP\Projects-R\R2814C\Traffic\Signing\CADD\PMR\R2814C_PMP_11.dgn
 Users\johns

APPROVED: *Ayman Alqudwah*
F324C5CAF985472
 DATE: 4/26/2018



DOCUMENT NOT CONSIDERED FINAL
 UNLESS ALL SIGNATURES COMPLETED

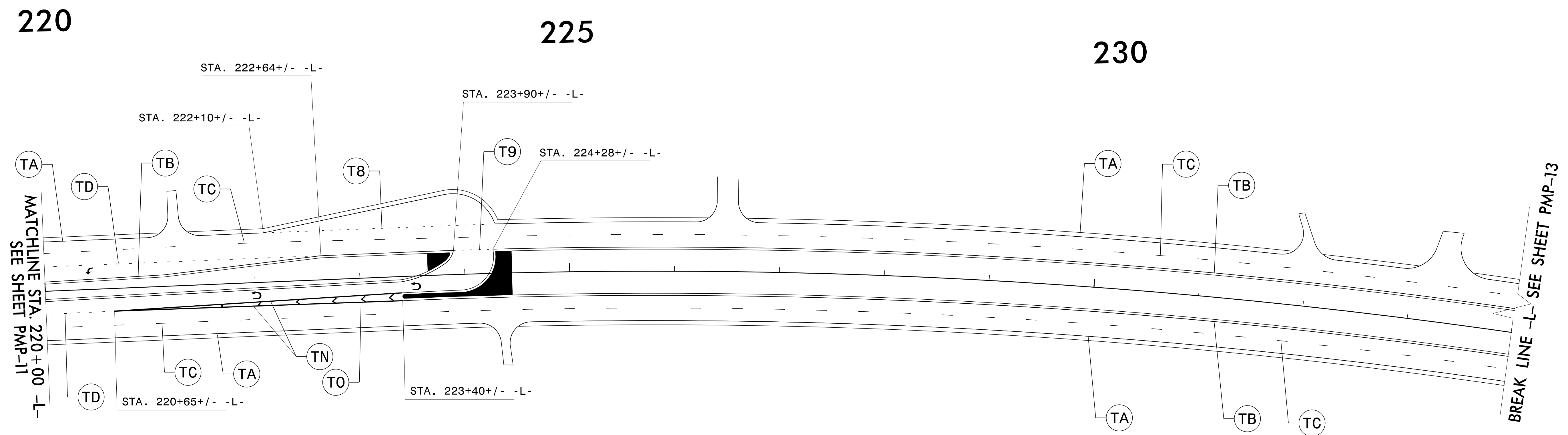
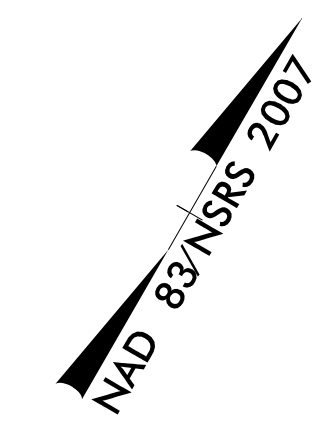

SYMBOL AND PAVEMENT MARKING LEGEND	
THERMOPLASTIC	
(T8)	2 FT.-6 FT./SP WHITE MINISKIP (4")
(T9)	2 FT.-6 FT./SP YELLOW MINISKIP (4")
(TA)	WHITE EDGELINE (4")
(TB)	YELLOW EDGELINE (4")
(TC)	10' WHITE SKIP (4")
(TD)	3 FT.-9 FT./SP WHITE MINISKIP (4")
(TN)	WHITE GORE LINE (8")
(TO)	WHITE DIAGONAL (8")
(JA)	LEFT TURN ARROW
(UT)	U-TURN ARROW

PAVEMENT MARKING DETAIL

04/24/18
 N:\TIP-Projects-R\R2814c\Traffic\Signing\CADD\PMR\R2814C_PMP_12.dgn
 Users\johns

255

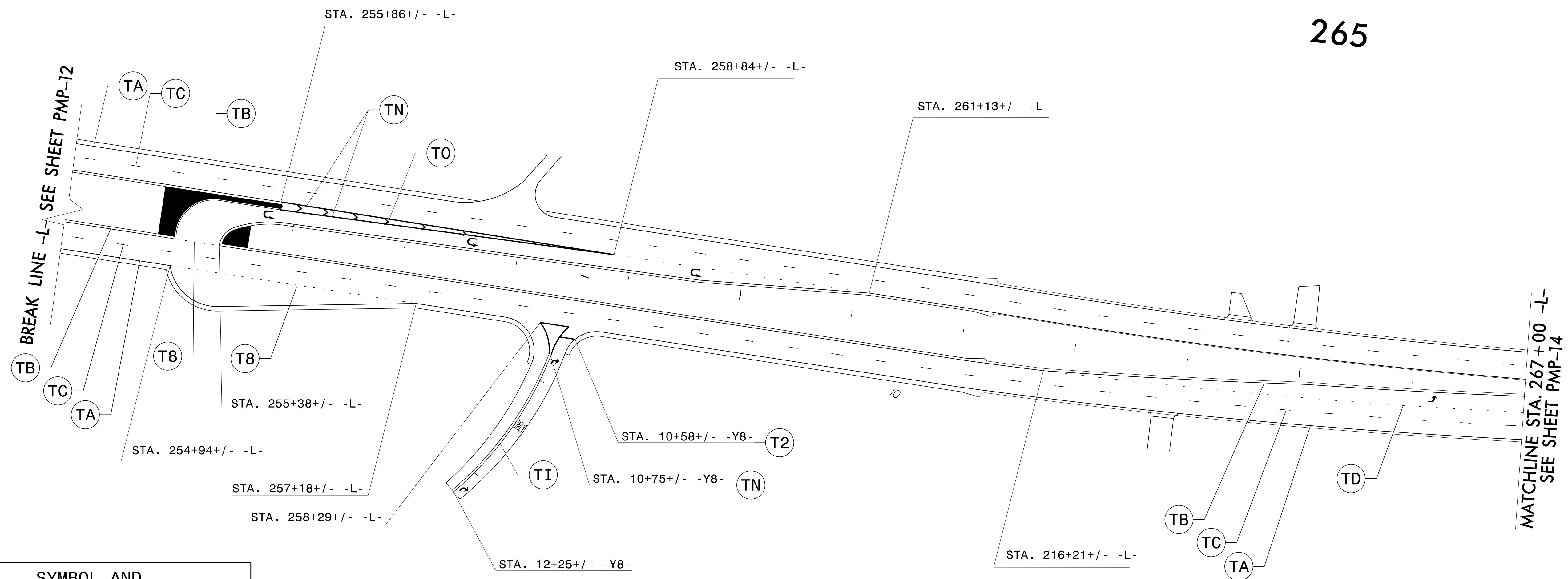
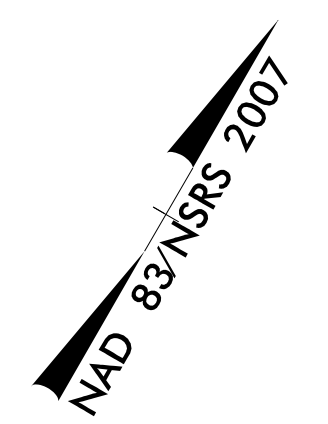

260

265



SYMBOL AND PAVEMENT MARKING LEGEND









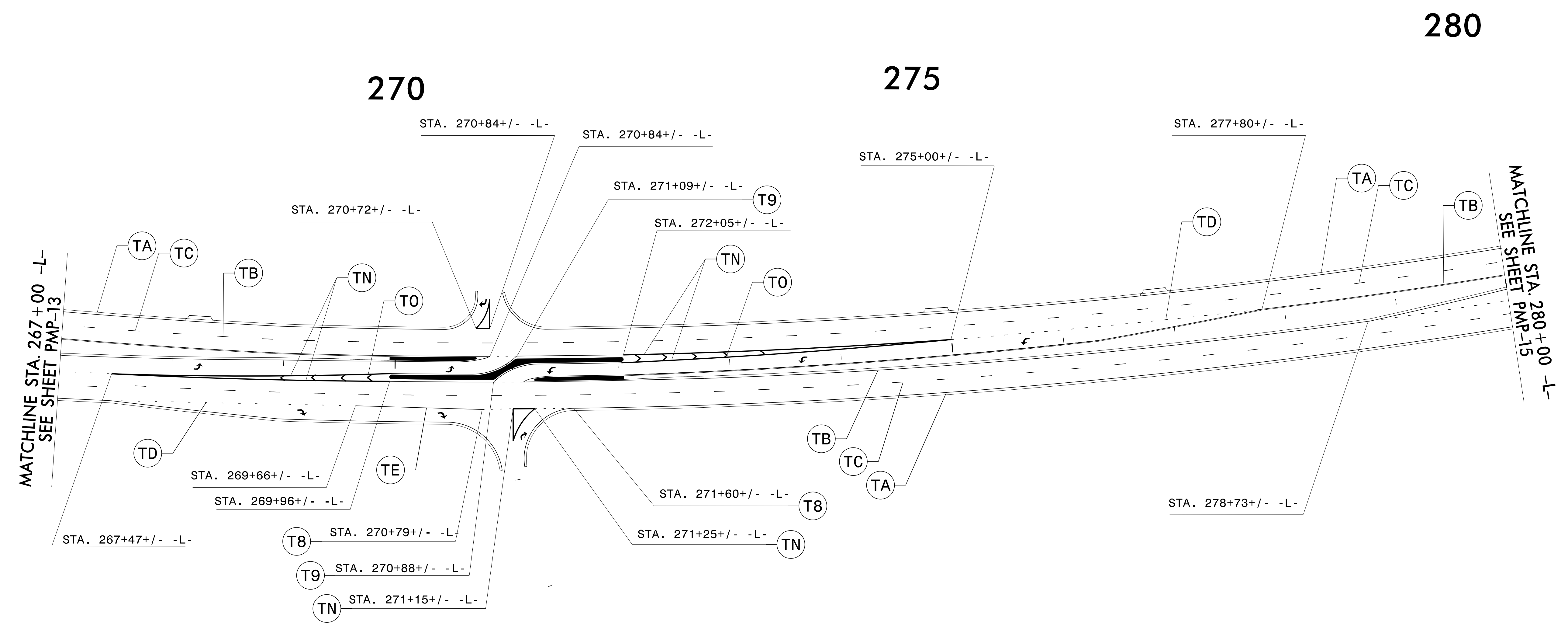
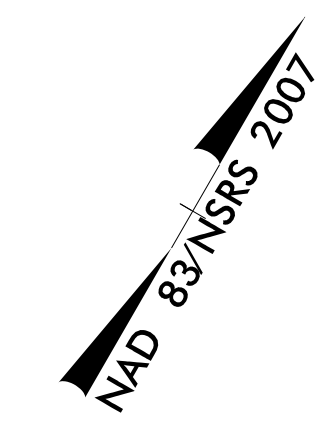

THERMOPLASTIC	
(T2)	WHITE STOPBAR (24")
(T8)	2FT.-6FT./SP WHITE MINISKIP (4")
(T9)	2FT.-6FT./SP YELLOW MINISKIP (4")
(TA)	WHITE EDGELINE (4")
(TB)	YELLOW EDGELINE (4")
(TC)	10' WHITE SKIP (4")
(TD)	3FT.-9FT./SP WHITE MINISKIP (4")
(TI)	YELLOW DOUBLE CENTER (4")
(TN)	WHITE GORE LINE (8")
(TO)	WHITE DIAGONAL (8")

	(UA) LEFT TURN ARROW
	(UB) RIGHT TURN ARROW
	(UT) U-TURN ARROW
ONLY (UI)	ALPHANUMERIC CHARACTER

PAVEMENT MARKING DETAIL

04/24/18
N:\TIP-Projects-R\R2814C\Traffic\Signing\CADD\PMR\R2814C_PMP_13.dgn
Users\johns



SYMBOL AND PAVEMENT MARKING LEGEND	
THERMOPLASTIC	
	2FT.-6FT./SP WHITE MINISKIP (4")
	2FT.-6FT./SP YELLOW MINISKIP (4")
	WHITE EDGELINE (4")
	YELLOW EDGELINE (4")
	10' WHITE SKIP (4")
	3FT.-9FT./SP WHITE MINISKIP (4")
	WHITE GORE LINE (8")
	WHITE DIAGONAL (8")
	LEFT TURN ARROW
	RIGHT TURN ARROW

PAVEMENT MARKING DETAIL

04/24/18
 N:\TIP\Projects-R\R2814C\Traffic\Signing\CADD\PMR\R2814C_PMP_14.dgn
 Users\johns

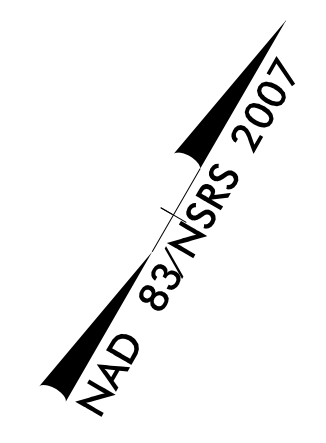







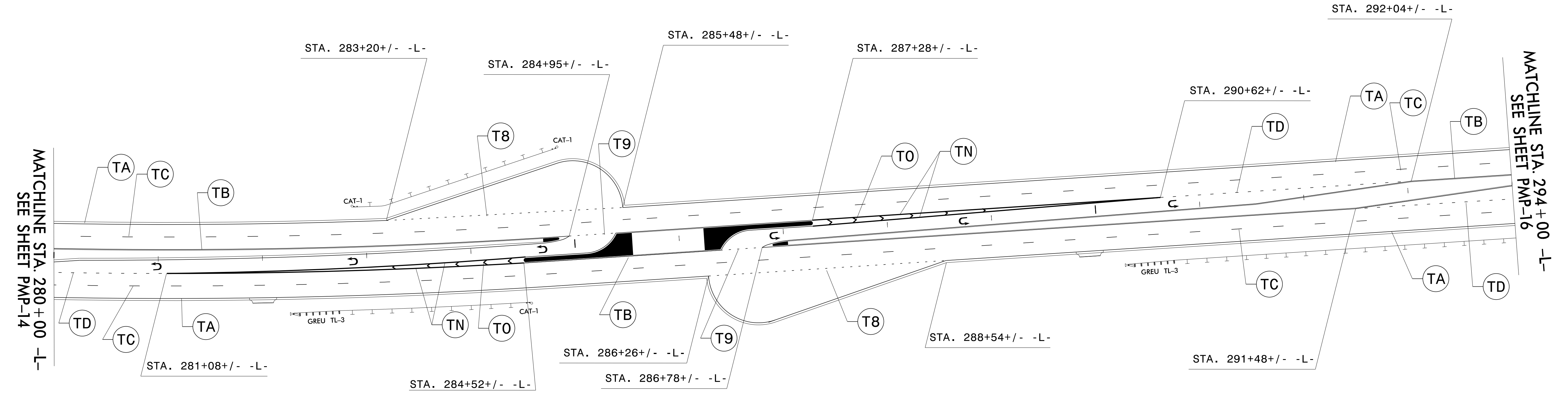

280

285

290



SYMBOL AND PAVEMENT MARKING LEGEND	
THERMOPLASTIC	
	2FT.-6FT./SP WHITE MINISKIP (4")
	2FT.-6FT./SP YELLOW MINISKIP (4")
	WHITE EDGELINE (4")
	YELLOW EDGELINE (4")
	10' WHITE SKIP (4")
	3FT.-9FT./SP WHITE MINISKIP (4")
	WHITE GORE LINE (8")
	WHITE DIAGONAL (8")
	U-TURN ARROW

PAVEMENT MARKING DETAIL

04/24/18
 N:\TIP-Projects-R\R2814c\Traffic\Signing\CADD\PMR\R2814C_PMP_15.dgn
 Users\johns

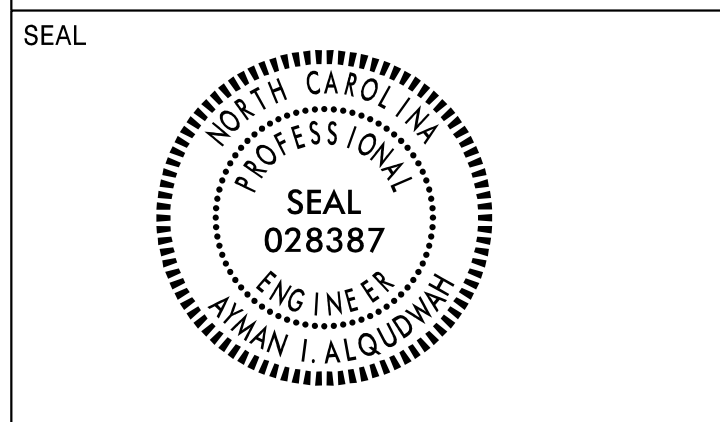

DOCUMENT NOT CONSIDERED FINAL
 UNLESS ALL SIGNATURES COMPLETED

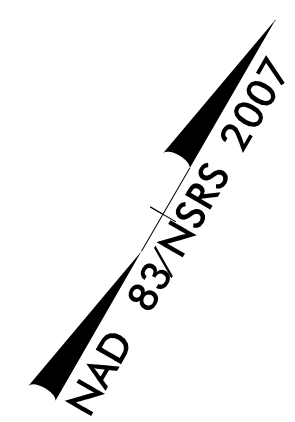

295 300 305

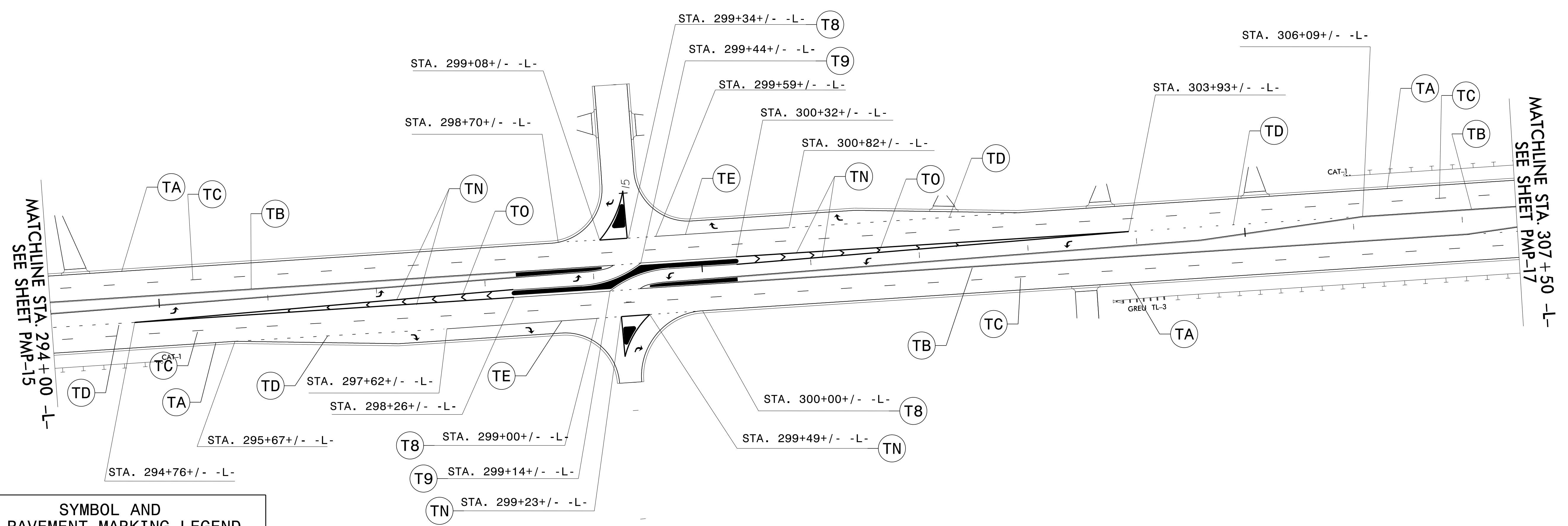

SYMBOL AND PAVEMENT MARKING LEGEND

- THERMOPLASTIC**
- (T8) 2FT.-6FT./SP WHITE MINISKIP (4")
 - (T9) 2FT.-6FT./SP YELLOW MINISKIP (4")
 - (TA) WHITE EDGELINE (4")
 - (TB) YELLOW EDGELINE (4")
 - (TC) 10' WHITE SKIP (4")
 - (TD) 3FT.-9FT./SP WHITE MINISKIP (4")
 - (TE) WHITE SOLID LANE LINE (4")
 - (TN) WHITE GORE LINE (8")
 - (TO) WHITE DIAGONAL (8")
- UA LEFT TURN ARROW
 UB RIGHT TURN ARROW

PAVEMENT MARKING DETAIL

04/24/18
 N:\TIP-Projects-R\R2814C\Traffic\Signing\CADD\PMR\R2814C_PMP_16.dgn
 Users\johns

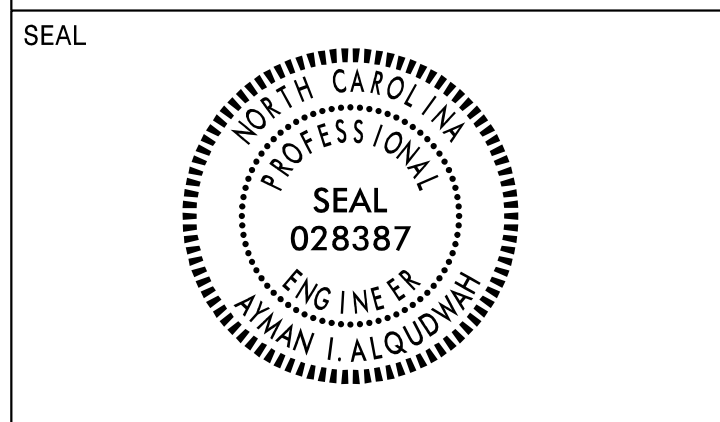

**DOCUMENT NOT CONSIDERED FINAL
 UNLESS ALL SIGNATURES COMPLETED**

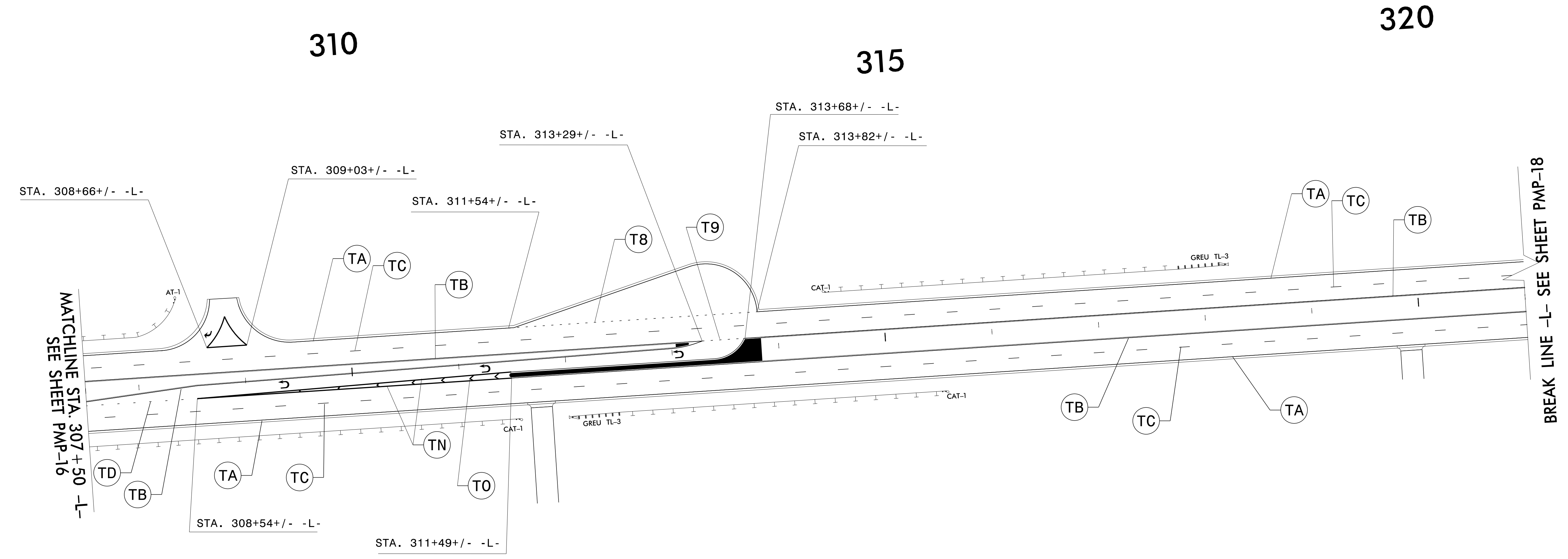
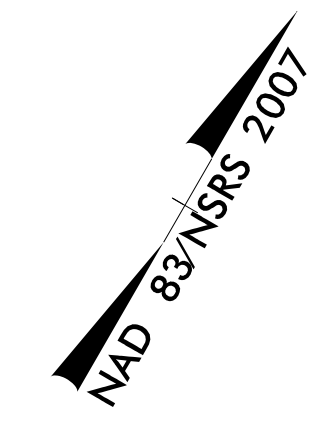

SYMBOL AND PAVEMENT MARKING LEGEND	
THERMOPLASTIC	
(T8)	2FT.-6FT./SP WHITE MINISKIP (4")
(T9)	2FT.-6FT./SP YELLOW MINISKIP (4")
(TA)	WHITE EDGELINE (4")
(TB)	YELLOW EDGELINE (4")
(TC)	10' WHITE SKIP (4")
(TD)	3FT.-9FT./SP WHITE MINISKIP (4")
(TN)	WHITE GORE LINE (8")
(TO)	WHITE DIAGONAL (8")
(UB)	RIGHT TURN ARROW
(UT)	U-TURN ARROW

PAVEMENT MARKING DETAIL

04/24/18
 N:\TIP-Projects-R\R2814c\Traffic\Signing\CADD\PMR\R2814C_PMP_17.dgn
 Users\johns

APPROVED: *Ayman Alqudwah*
F32AC5CAF685472
DATE: 4/26/2018



DOCUMENT NOT CONSIDERED FINAL
UNLESS ALL SIGNATURES COMPLETED

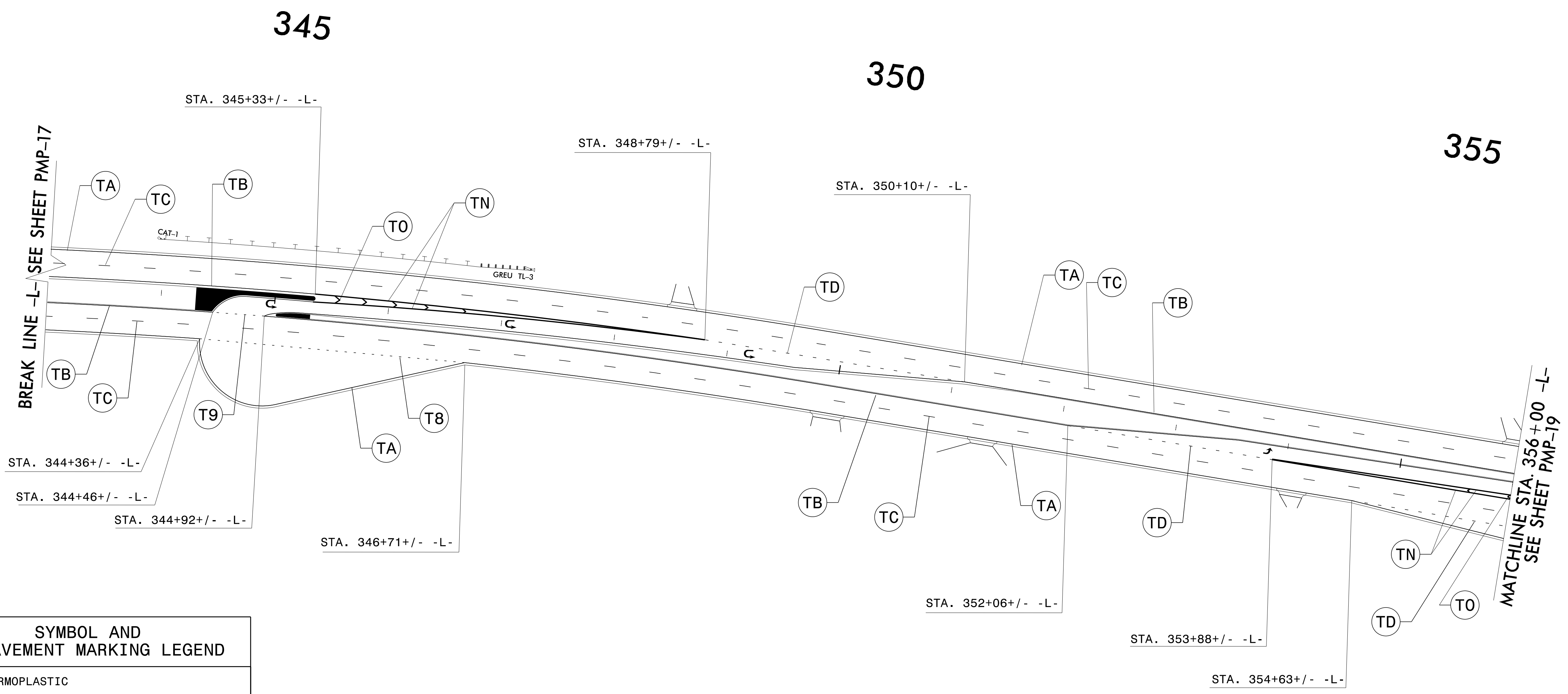
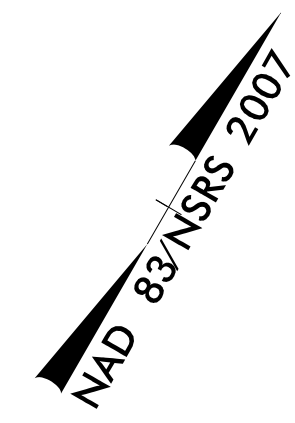

SYMBOL AND PAVEMENT MARKING LEGEND	
THERMOPLASTIC	
(T8)	2FT.-6FT./SP WHITE MINISKIP (4")
(T9)	2FT.-6FT./SP YELLOW MINISKIP (4")
(TA)	WHITE EDGELINE (4")
(TB)	YELLOW EDGELINE (4")
(TC)	10' WHITE SKIP (4")
(TD)	3FT.-9FT./SP WHITE MINISKIP (4")
(TN)	WHITE GORE LINE (8")
(TO)	WHITE DIAGONAL (8")
(UT)	U-TURN ARROW
(UA)	LEFT TURN ARROW

PAVEMENT MARKING DETAIL

04/24/18
 N:\TIP\Projects-R\R2814c\Traffic\Signing\CADD\MPR\R2814C_PMP_18.dgn
 Users\johns

APPROVED: *Ayman Alqudwah*
DocuSigned by:
 Ayman Alqudwah
 F32AC5CAF685472
 4/26/2018

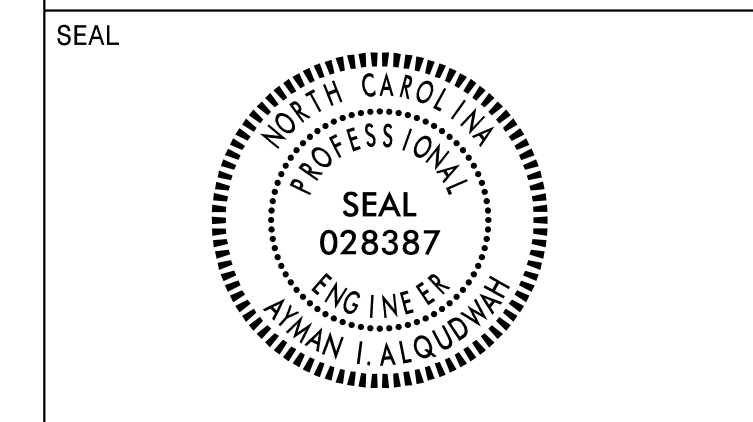

**DOCUMENT NOT CONSIDERED FINAL
 UNLESS ALL SIGNATURES COMPLETED**

SYMBOL AND PAVEMENT MARKING LEGEND

- THERMOPLASTIC**
- (T2) WHITE STOPBAR (24")
 - (T9) 2FT.-6FT./SP YELLOW MINISKIP (4")
 - (TA) WHITE EDGELINE (4")
 - (TB) YELLOW EDGELINE (4")
 - (TC) 10' WHITE SKIP (4")
 - (TD) 3FT.-9FT./SP WHITE MINISKIP (4")
 - (TE) WHITE SOLID LANE LINE (4")
 - (TF) 10' YELLOW SKIP (4")
 - (TH) YELLOW SINGLE CENTER (4")
 - (TI) YELLOW DOUBLE CENTER (4")
 - (TN) WHITE GORE LINE (8")
 - (TO) WHITE DIAGONAL (8")
 - (TP) YELLOW DIAGONAL (8")

- ↶ (UA) LEFT TURN ARROW
- ↷ (UB) RIGHT TURN ARROW
- ONLY (UI) ALPHANUMERIC CHARACTER
- ▲ (UN) 24" YIELD LINE TRIANGLE
- ↘ (UP) MERGE ARROW
- ↶ (UT) U-TURN ARROW

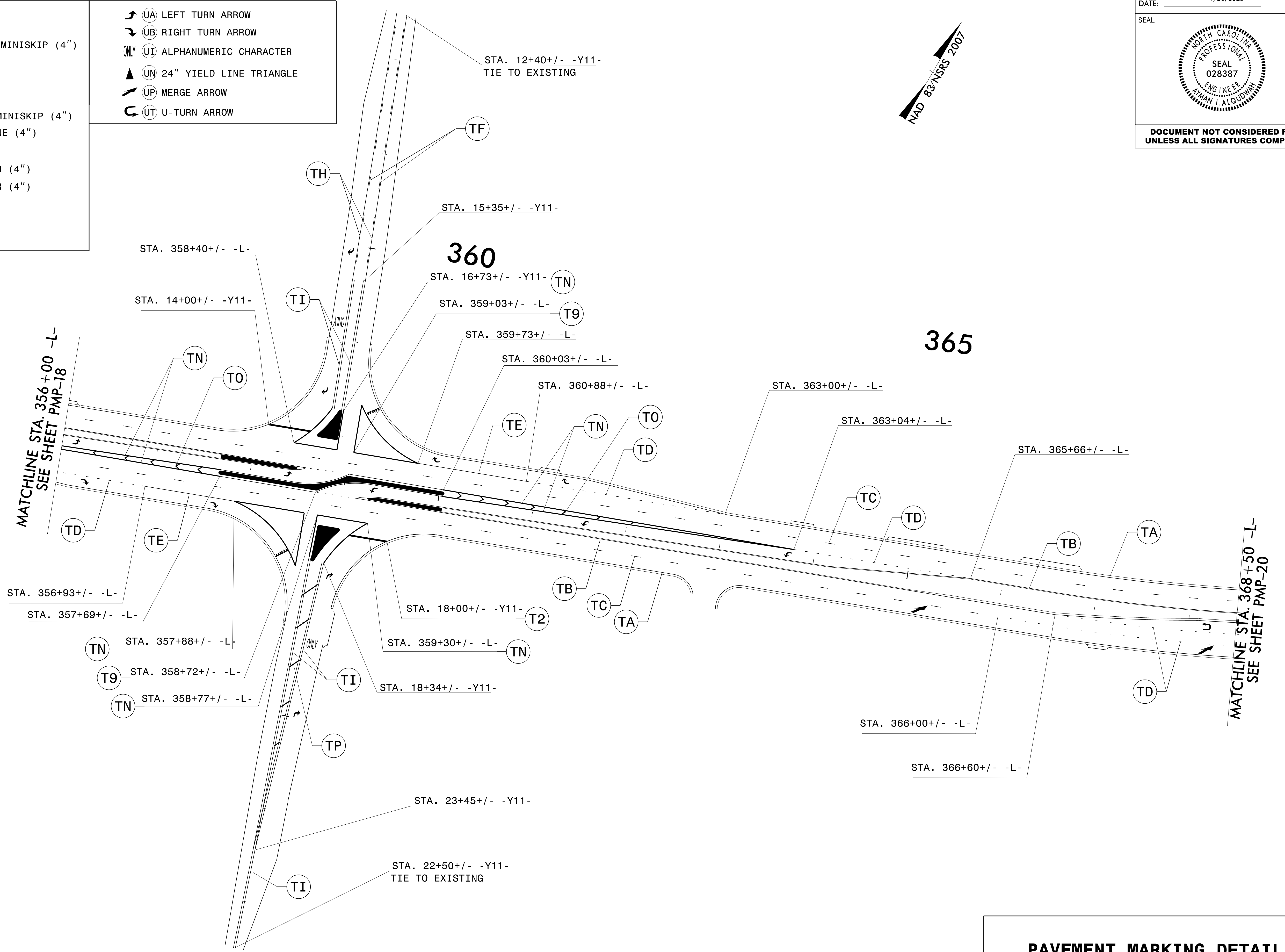

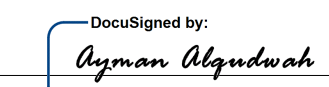

PAVEMENT MARKING DETAIL

04/24/18
 I:\TIP-Projects-R\R2814c-Traffic\Signing\CADD\PMR\R2814C_PMP_19.dgn
 Users\johns

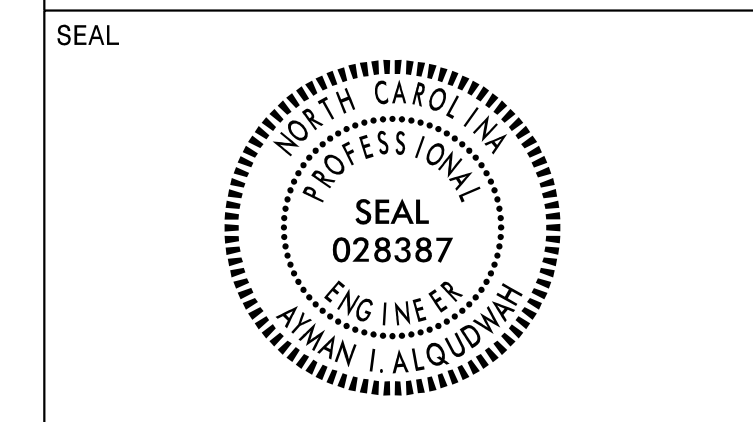
APPROVED: 
F324C5CAF685472
 DATE: 4/26/2018



**DOCUMENT NOT CONSIDERED FINAL
UNLESS ALL SIGNATURES COMPLETED**

SYMBOL AND PAVEMENT MARKING LEGEND	
THERMOPLASTIC	
(T8)	2FT.-6FT./SP WHITE MINISKIP (4")
(T9)	2FT.-6FT./SP YELLOW MINISKIP (4")
(TA)	WHITE EDGELINE (4")
(TB)	YELLOW EDGELINE (4")
(TC)	10' WHITE SKIP (4")
(TD)	3FT.-9FT./SP WHITE MINISKIP (4")
(TI)	YELLOW DOUBLE CENTER (4")
(TN)	WHITE GORE LINE (8")
(TO)	WHITE DIAGONAL (8")
(TP)	YELLOW DIAGONAL (8")
 (UT)	U-TURN ARROW
 (UP)	MERGE ARROW

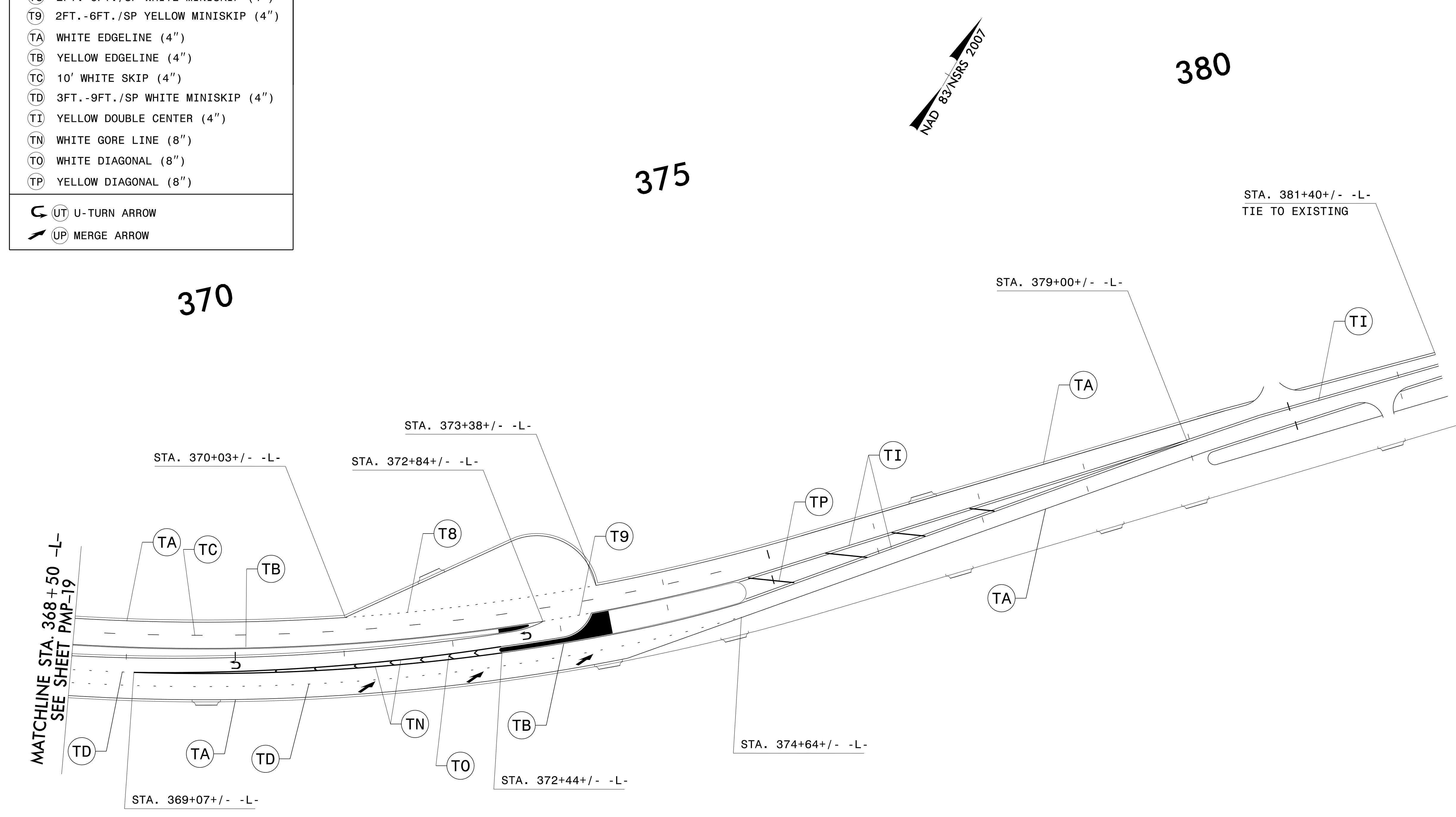

04/24/18
 N:\TIP\Projects-R\R2814c\Traffic\Signing\CADD\PMR\R2814C_PMP_20.dgn
 Users\johns

PAVEMENT MARKING DETAIL