

Welded Ring Stiffened Mast Arm Connection

PROJECT ID. NO.

SHEET NO.

U-5169

Sig.M5

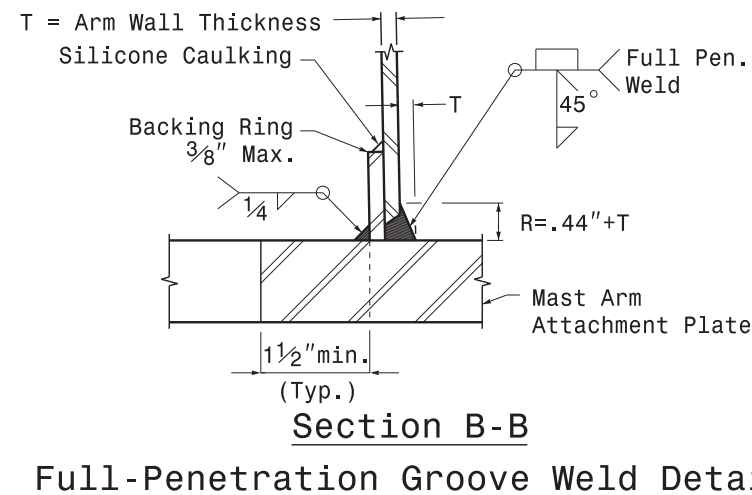
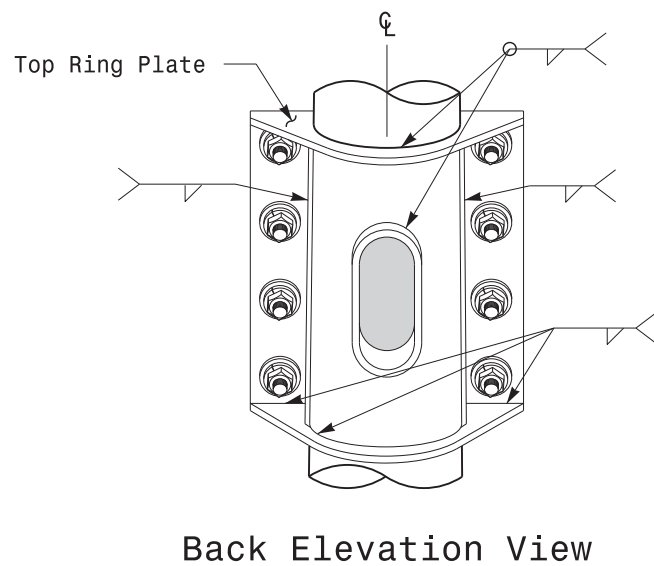
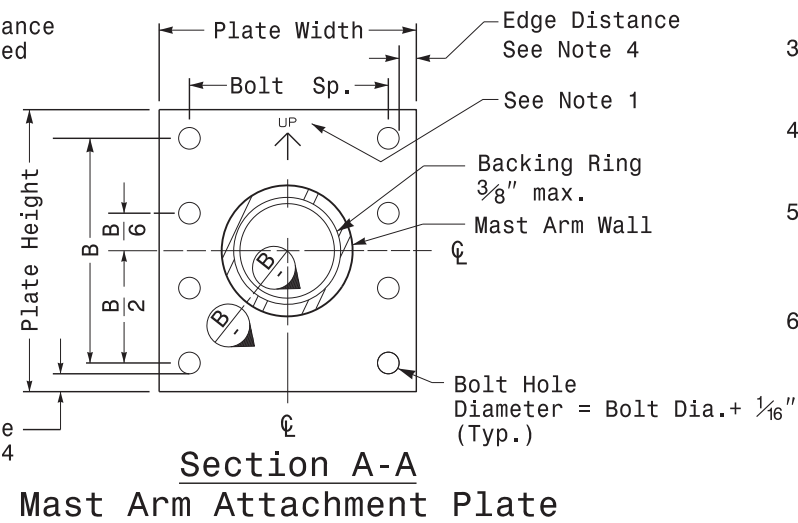
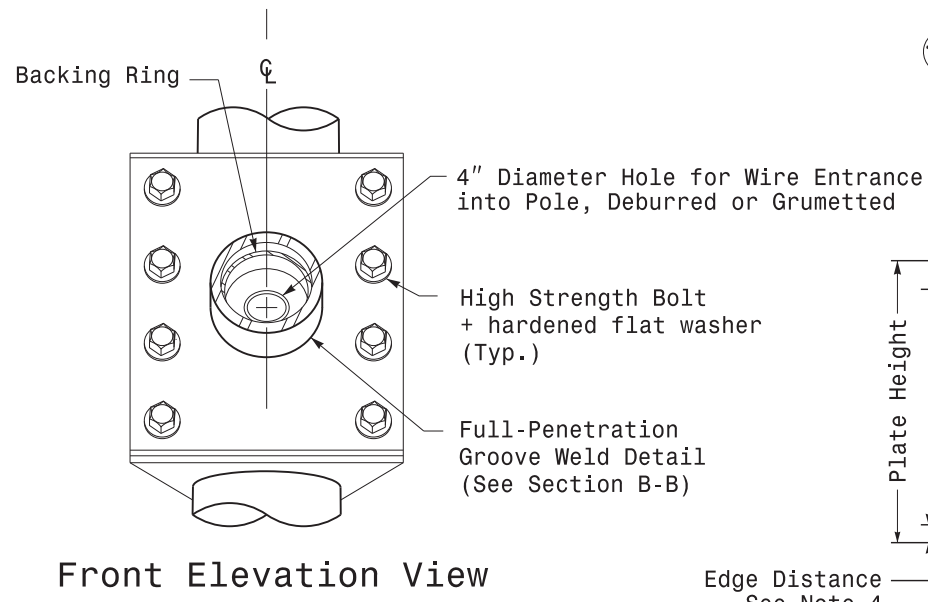
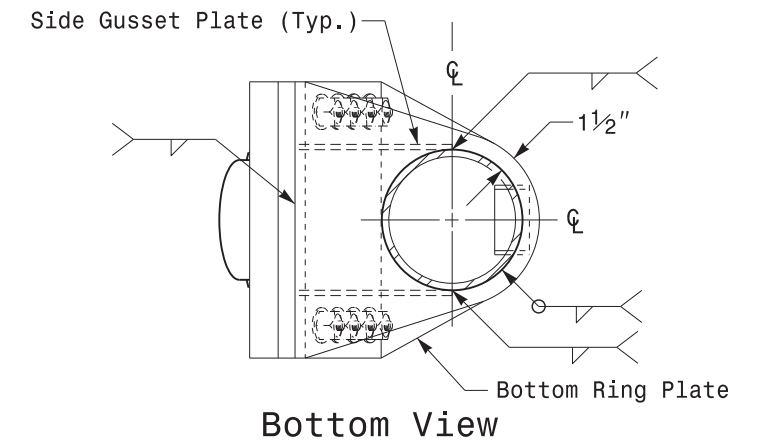
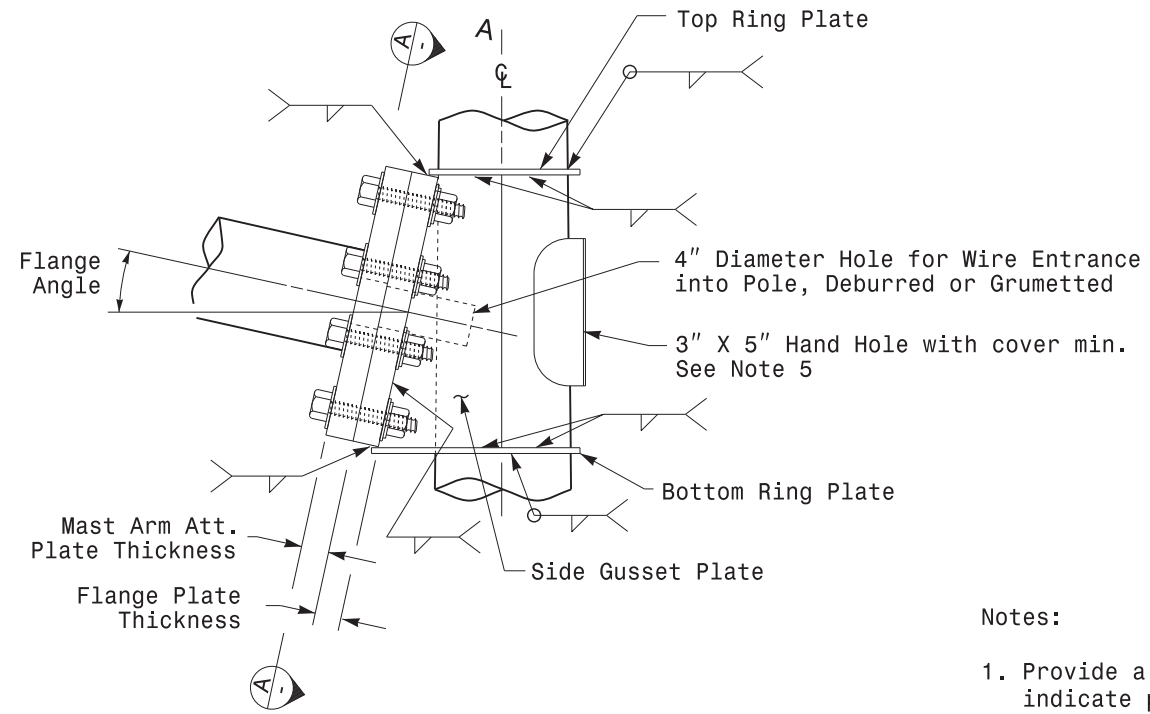
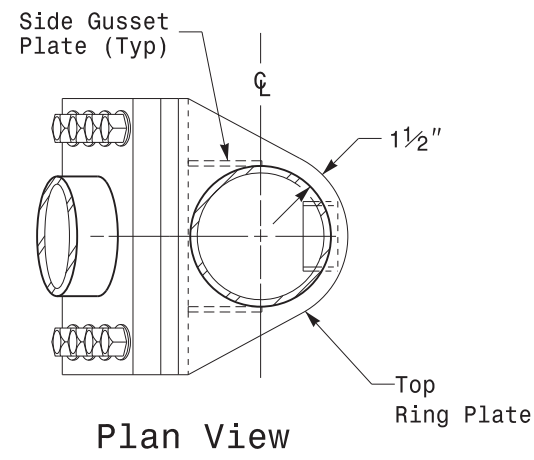

Notes:

1. Provide a permanent means of identification above the mast arm to indicate proper attachment orientation of the mast arm.
2. Designer will determine the size of all structural components, plates, fasteners, and welds shown unless they are already specified.
3. Fabricator is responsible for providing appropriate holes at drainage points to drain galvanizing materials.
4. For minimum edge distance follow AISC Table J3.4 and J3.5. For nominal bolt hole size use Table J3.3.
5. Provide upper handhole as necessary when shaft extensions are required for luminaire arms or camera. For poles without luminaires/camera, wiring can be done through the top of pole.
6. Allowable range of flange tilt angle will vary from 0° to as required.

11-0CT-2017-08:35 11850M115 Stipulations: Ignor Design Section Eastern Region M Sheets 2016 2014 Sig. M5 Std. Connection Fabrication Detail is Mast Arm Poles.dgn PZ:GSR

Fabrication Details - Mast Arm Connection

<p>Prepared in the Offices of:</p> <p>750 N. Greenfield Pkwy, Garner, NC 27529</p>	<p>Typical Fabrication Details For Mast Arm Connection To Pole</p>		
	<p>PLAN DATE: OCTOBER 2017</p> <p>PREPARED BY: N. BITTING</p>	<p>DESIGNED BY: C.F. ANDREWS</p> <p>REVIEWED BY: D.C. SARKAR</p>	
<p>SCALE: 0 NA NONE</p>	<p>REVISIONS</p>	<p>INIT.</p>	<p>DATE</p>
<p>Designed by: Debesh C. Sarkar</p>			<p>10/11/2017</p> <p>DATE</p>