

ELEVATION OF HANDRAIL

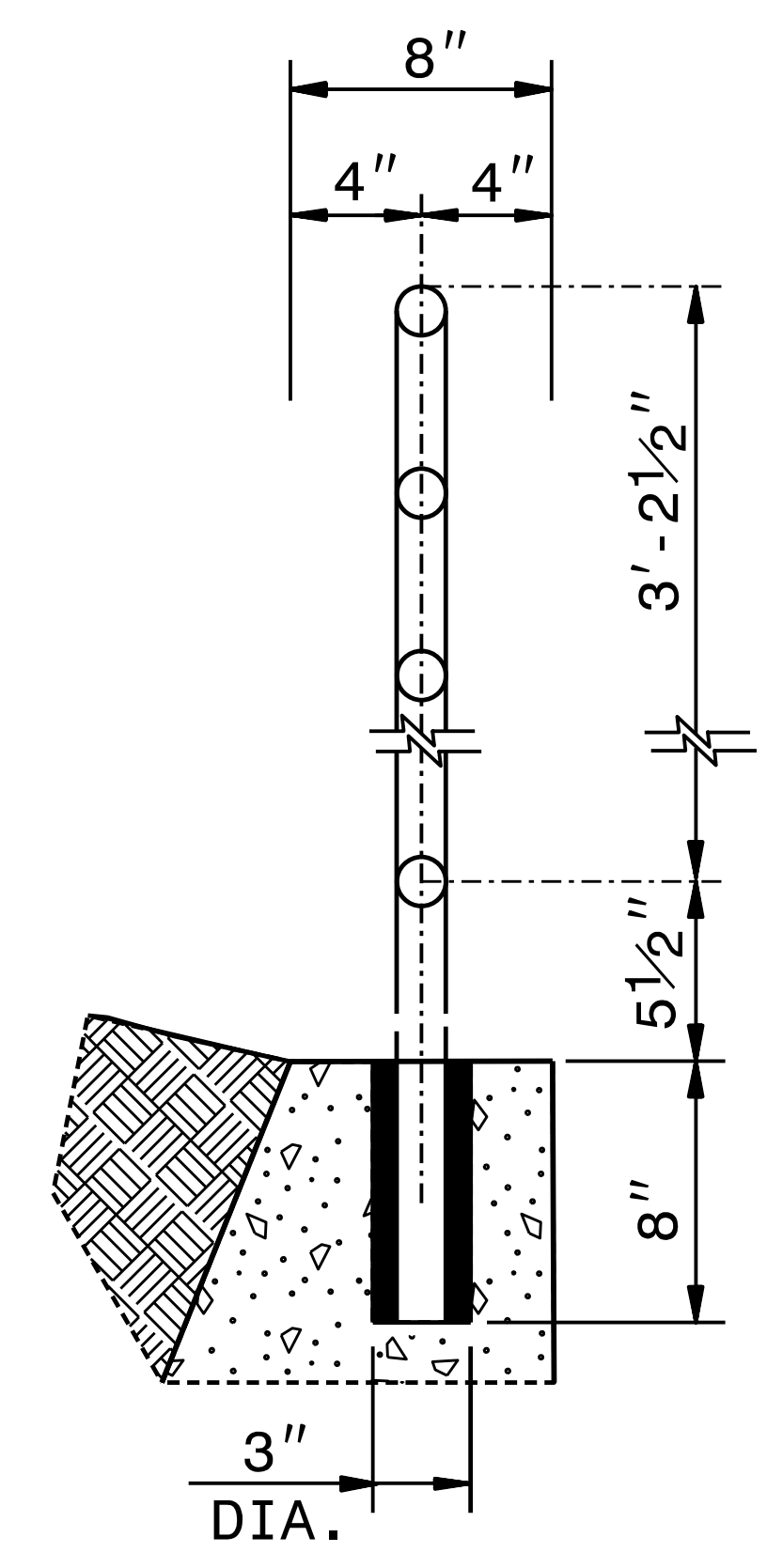

INSET 'A'

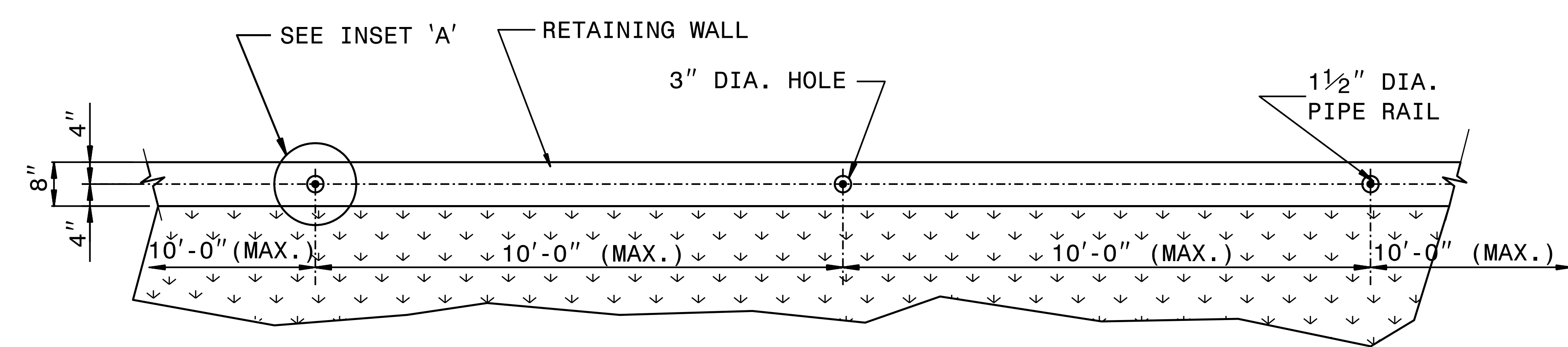

PLAN VIEW

NOTES:

- CONSTRUCT PROPOSED STEEL PIPE RAIL 1 1/2" DIAMETER SCHEDULE 40 PLAIN END GALVANIZED STEEL PIPE MEETING THE REQUIREMENTS OF ASTM A53.
- EMBED PIPE RAIL 8" INTO PROPOSED WALL WITH CHEMICAL OR CONCRETE GROUT ANCHORING SYSTEM AS DIRECTED BY THE ENGINEER.
- REPAIR GALVANIZING IN ACCORDANCE WITH SECTION 1076 OF THE NCDOT STANDARD SPECIFICATIONS.
- PAINT, IF REQUIRED BY THE ENGINEER, IN ACCORDANCE WITH SECTION 1080 OF THE STANDARD SPECIFICATIONS.
- CENTER THE PROPOSED RAILING ON TOP OF THE WALL WITH POST SPACING SYMMETRICAL ABOUT THE CENTER-LINE OF THE WALL.
- USE A ROTARY DRILL IF NEEDED FOR EMBEDMENT HOLES OF RAIL IN WALL. ROTARY DRILL ONLY (NO ROTARY-IMPACT DRILLS).
- WELD IN ACCORDANCE WITH ARTICLE 1072-18 OF THE STANDARD SPECIFICATIONS.

\$\$\$\$\$SYTIME\$\$\$\$\$
\$\$\$\$\$CUSTNAME\$\$\$\$\$
\$\$\$\$\$DUSERNAME\$\$\$\$\$

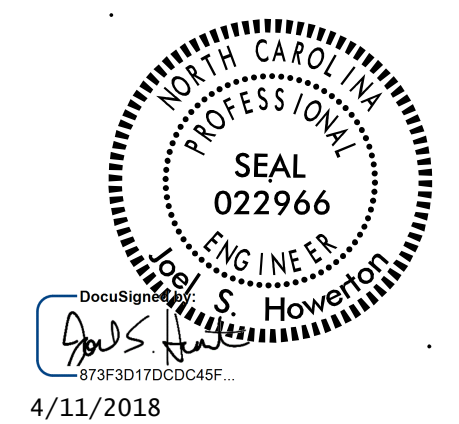

DOCUMENT NOT CONSIDERED FINAL
UNLESS ALL SIGNATURES COMPLETED

**CONTRACT STANDARDS
AND DEVELOPMENT UNIT**
Office 919-707-6950 FAX 919-250-4119

**DETAIL OF PIPE HANDRAIL
MOUNTED ON RETAINING WALL**

ORIGINAL BY: E.E. WARD	DATE: 12-99
MODIFIED BY:	DATE:
CHECKED BY:	DATE:
FILE SPEC.: jhowerton/handrail_on_retaining_wall.dgn	