

EDI MODEL 2018ECL-NC CONFLICT MONITOR PROGRAMMING DETAIL

(remove jumpers and set switches as shown)

REMOVE DIODE JUMPERS 1-5, 1-6, 1-9, 1-11, 2-5, 2-6, 2-9, 2-11, 4-8, 5-9, 5-11, 6-9, 6-11, and 9-11.

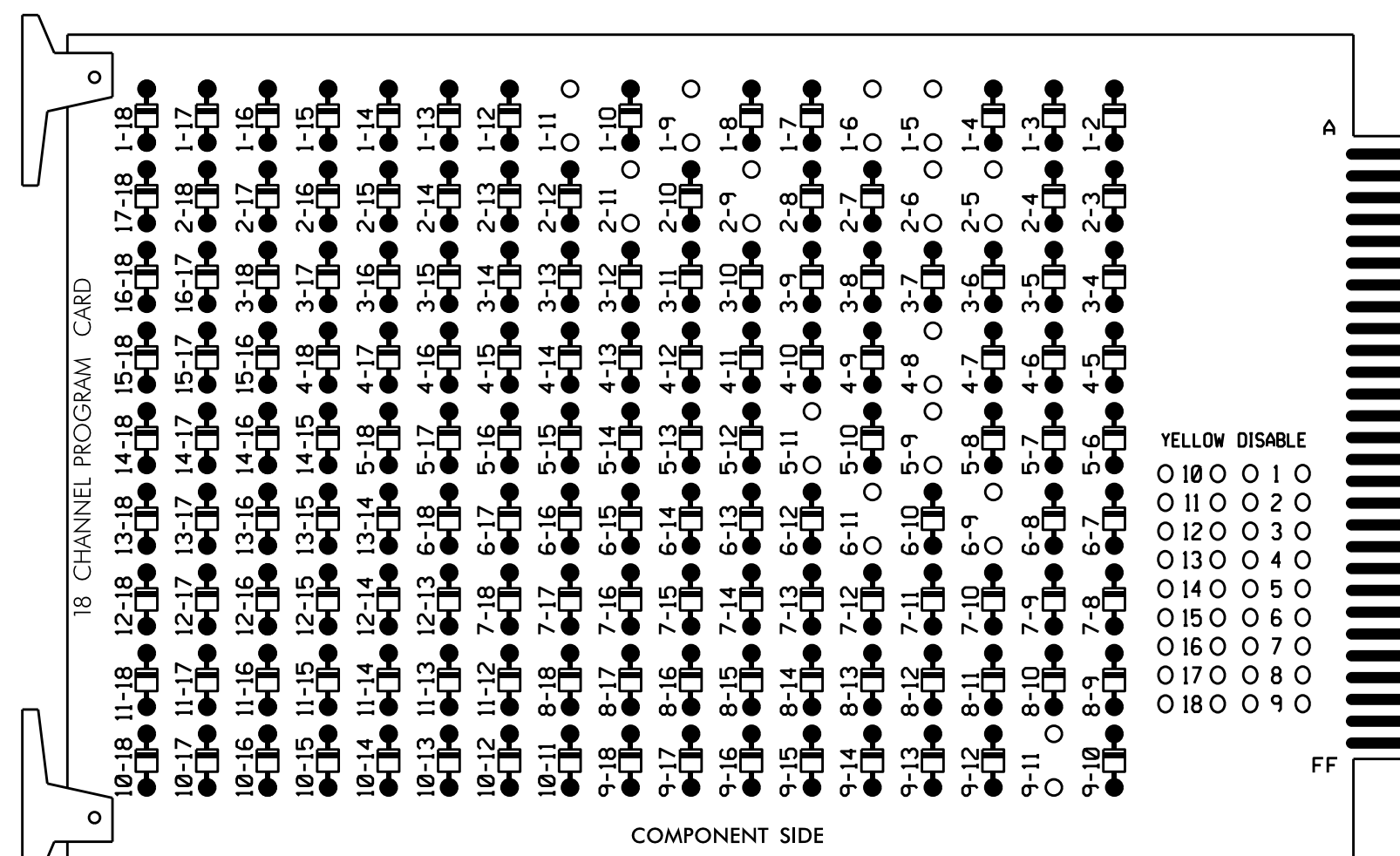

REMOVE JUMPERS AS SHOWN

NOTES:

- Card is provided with all diode jumpers in place. Removal of any jumper allows its channels to run concurrently.
- Ensure jumpers SEL2-SEL5 and SEL9 are present on the monitor board.
- Ensure that Red Enable is active at all times during normal operation.
- Connect serial cable from conflict monitor to comm. port 1 of 2070 controller. Ensure conflict monitor communicates with 2070.

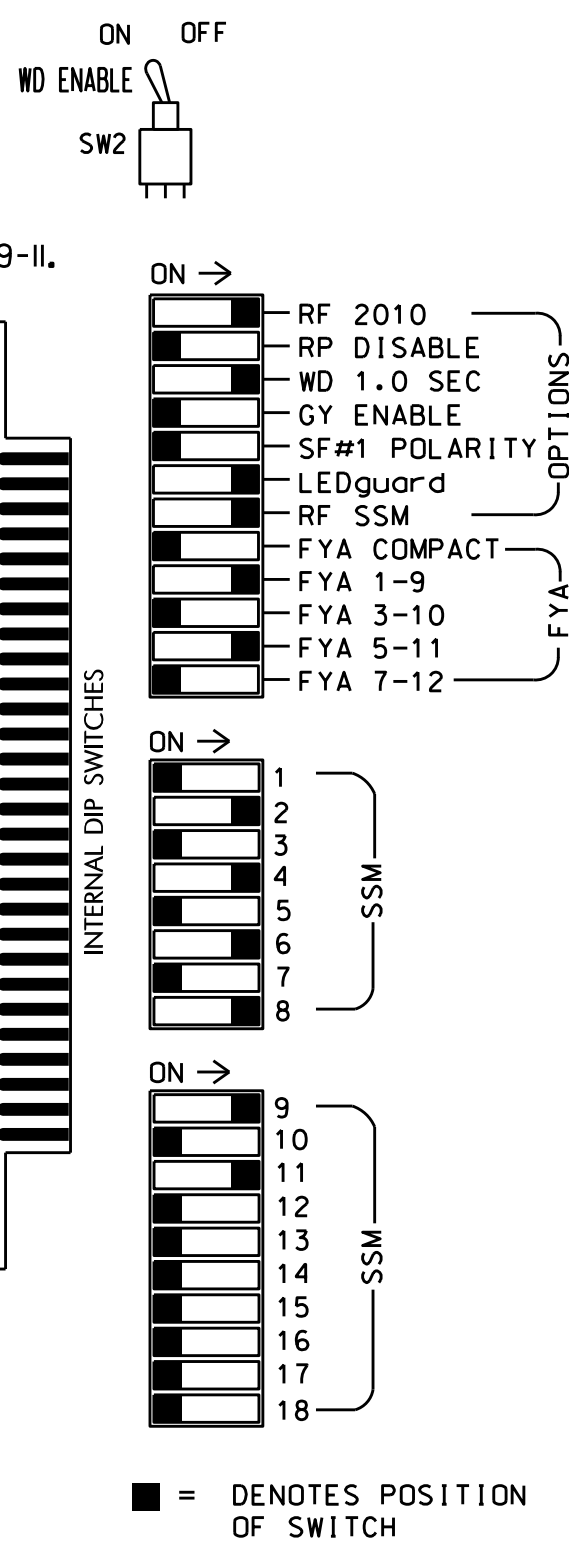

NOTES

- To prevent "flash-conflict" problems, insert red flash program blocks for all unused vehicle load switches in the output file. The installer shall verify that signal heads flash in accordance with the Signal Plans.
- Return controller to Factory Defaults before programming per this electrical detail.
- Program phases 4 and 8 for Dual Entry.
- Enable Simultaneous Gap-Out for all Phases.
- Program phases 2 and 6 for Variable Initial and Gap Reduction.
- Program phases 2 and 6 for Startup In Green.
- Program phases 2 and 6 for Yellow Flash, and overlap 1 as Wag Overlaps.

EQUIPMENT INFORMATION

CONTROLLER.....2070
 CABINET.....332 W/ AUX
 SOFTWARE.....ECONOLITE OASIS
 CABINET MOUNT.....BASE
 OUTPUT FILE POSITIONS...18 WITH AUX. OUTPUT FILE
 LOAD SWITCHES USED.....S1,S2,S5,S7,S8,S11,AUX S1,AUX S4
 PHASES USED.....1,2,4,5,6,8
 OVERLAP "A".....1+2
 OVERLAP "B".....NOT USED
 OVERLAP "C".....5+6
 OVERLAP "D".....NOT USED

SIGNAL HEAD HOOK-UP CHART

LOAD SWITCH NO.	S1	S2	S3	S4	S5	S6	S7	S8	S9	S10	S11	S12	AUX S1	AUX S2	AUX S3	AUX S4	AUX S5	AUX S6
CMU CHANNEL NO.	1	2	13	3	4	14	5	6	15	7	8	16	9	10	17	11	12	18
PHASE	1	2	2 PED	3	4	4 PED	5	6	6 PED	7	8	8 PED	OLA	OLB	SPARE	OLC	OLD	SPARE
SIGNAL HEAD NO.	11	21,22,23	NU	NU	41,42,43	NU	51	61,62,63	NU	NU	81,82,83	NU	11	NU	NU	51	NU	NU
RED		128			101			134			107							
YELLOW	*	129			102		*	135			108							
GREEN		130			103			136			109							
RED ARROW													A121				A114	
YELLOW ARROW													A122				A115	
FLASHING YELLOW ARROW													A123				A116	
GREEN ARROW	127							133										

NU = Not Used

* Denotes install load resistor. See load resistor installation detail this sheet.

★ See pictorial of head wiring in detail this sheet.

INPUT FILE POSITION LAYOUT

(front view)

FILE	1	2	3	4	5	6	7	8	9	10	11	12	13	14
U	∅ 1 1A	∅ 2 2A	∅ 3 3A	∅ 4 4A	∅ 5 5A	∅ 6 6A	∅ 7 7A	∅ 8 8A	∅ 9 9A	∅ 10 10A	∅ 11 11A	∅ 12 12A	∅ 13 13A	∅ 14 14A
L	NOT USED	∅ 2 2B	∅ 3 3B	NOT USED	∅ 5 5B	∅ 6 6B	∅ 7 7B	∅ 8 8B	∅ 9 9B	∅ 10 10B	∅ 11 11B	∅ 12 12B	∅ 13 13B	∅ 14 14B
U	∅ 1 1A	∅ 2 2A	∅ 3 3A	∅ 4 4A	∅ 5 5A	∅ 6 6A	∅ 7 7A	∅ 8 8A	∅ 9 9A	∅ 10 10A	∅ 11 11A	∅ 12 12A	∅ 13 13A	∅ 14 14A
L	NOT USED	∅ 2 2B	∅ 3 3B	NOT USED	∅ 5 5B	∅ 6 6B	∅ 7 7B	∅ 8 8B	∅ 9 9B	∅ 10 10B	∅ 11 11B	∅ 12 12B	∅ 13 13B	∅ 14 14B

EX.: 1A, 2A, ETC. = LOOP NO.'S

FS = FLASH SENSE
 ST = STOP TIME

⊗ Wired Input - Do not populate slot with detector card

See AC Isolator programming detail on sheet 6.

INPUT FILE CONNECTION & PROGRAMMING CHART

LOOP NO.	LOOP TERMINAL	INPUT FILE POS.	PIN NO.	INPUT ASSIGNMENT NO.	DETECTOR NO.	NEMA PHASE	CALL	EXTEND	FULL TIME DELAY	STRETCH TIME	DELAY TIME
1A ¹	TB2-1,2	I1U	56	18	1	1	Y	Y			15
	-	J4U	48	10★	26	6	Y	Y	Y		3
	-	I1U	56	18★	51	1	Y	Y			
2A	TB2-5,6	I2U	39	1	2	2	Y	Y			
2B	TB2-7,8	I2L	43	5	12	2	Y	Y			
4A	TB4-9,10	I6U	41	3	4	4	Y	Y			10
5A ²	TB3-1,2	J1U	55	17	5	5	Y	Y			15
	-	I4U	47	9★	22	2	Y	Y	Y		3
	-	J1U	55	17★	55	5	Y	Y			
6A	TB3-5,6	J2U	40	2	6	6	Y	Y			
6B	TB3-7,8	J2L	44	6	16	6	Y	Y			
8A	TB5-9,10	J6U	42	4	8	8	Y	Y			10

¹Add jumper from I1-W to J4-W, on rear of input file.

²Add jumper from J1-W to I4-W, on rear of input file.

★ See Input Page Assignment programming details on sheets 3 and 4.

INPUT FILE POSITION LEGEND: J2L

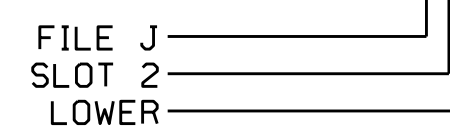

FYA SIGNAL WIRING DETAIL

(wire signal heads as shown)

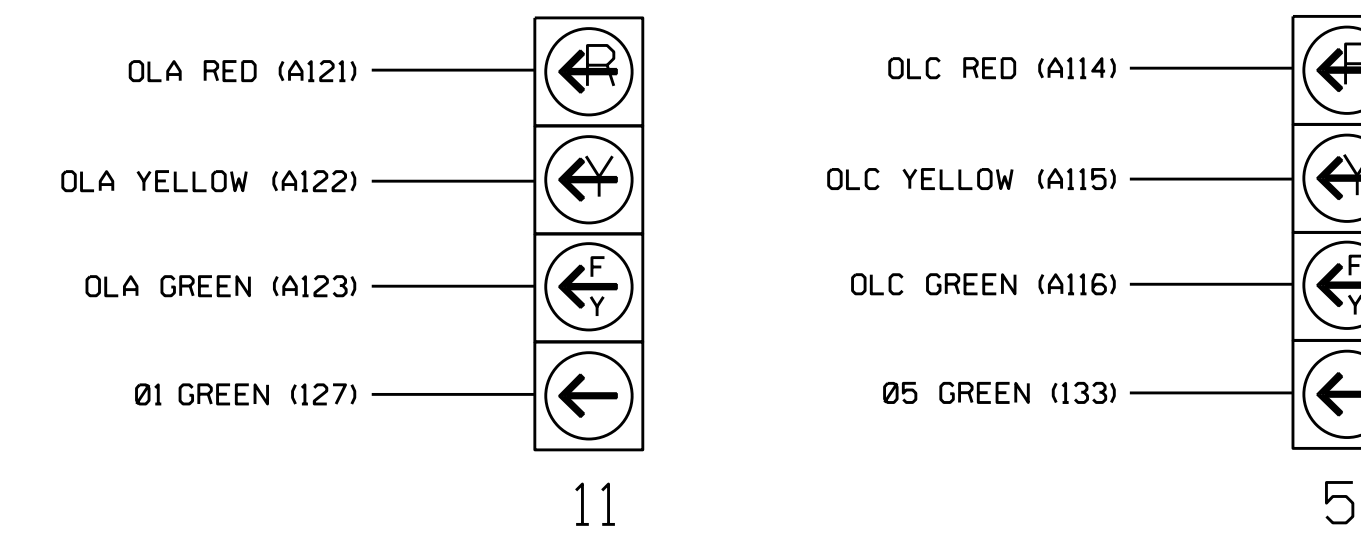

NOTE

The sequence display for signal heads 11 and 51 requires special logic programming. See sheet 2 for programming instructions.

THIS ELECTRICAL DETAIL IS FOR THE SIGNAL DESIGN: 07-1191T4
 DESIGNED: January 2018
 SEALED: 2/7/2018
 REVISED: N/A

LOAD RESISTOR INSTALLATION DETAIL

(install resistors as shown below)

VALUE (ohms)	WATTAGE
1.5K - 1.9K	25W (min)
2.0K - 3.0K	10W (min)

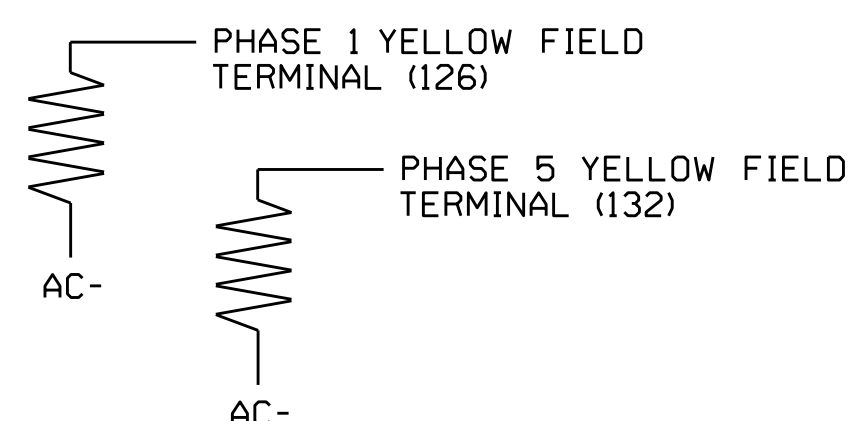

Electrical Detail - Temporary Design 4 (TMP Phase IV)
 Sheet 1 of 8

DOCUMENT NOT CONSIDERED FINAL UNLESS ALL SIGNATURES COMPLETED

Prepared In the Offices of:
 G.L. Transportation, Mobility and Safety Division
 NORTH CAROLINA DEPARTMENT OF TRANSPORTATION
 Signal Management Section
 750 N. Greenfield Pkwy, Garner, NC 27529

DETAILS FOR: I-85 Bus. / US 29-70 at SR 1144 (River Road)

Division 7 Guilford County Jamestown

PLAN DATE: February 2018 REVIEWED BY:
 PREPARED BY: S. Armstrong REVIEWED BY:

REVISIONS INIT. DATE

Seal: KEITH M. MINIS, ENGINEER, 036880

DocuSigned by: Keith M. Minis 2/8/2018
 2780796E8CD3445 DATE

SIG. INVENTORY NO. 07-1191T4