

(wire unit as shown below)

NOTES

1. Loop spacing is critical to the proper operation of this Overspeed Detection system. Make sure loop spacing is correctly programmed in the NQ4 unit.
2. The NQ4 unit shall be located in an auxiliary cabinet adjacent to the Long Vehicle Overspeed Detection loops.
3. Relay K1 is an enclosed SPDT general purpose relay with a 120VAC coil, 10A contacts, and octal style plug.
4. The RC network across the coil of K1 is 0.1 micro farad, 100 ohm.
5. EDCO SPA-60BS is a surge protector for 120VAC interconnect circuits.
6. EDCO SHP300-10 is an AC service surge protector.
7. Terminal strips TB1, TB2, TB3, and TBB to be added by the installer.
8. DO NOT install ground rods at the auxiliary cabinet.
9. Install equipment ground from the controller cabinet to the auxiliary cabinet if not already present.
10. Install a disconnect at the auxiliary cabinet if there is no disconnect already present.

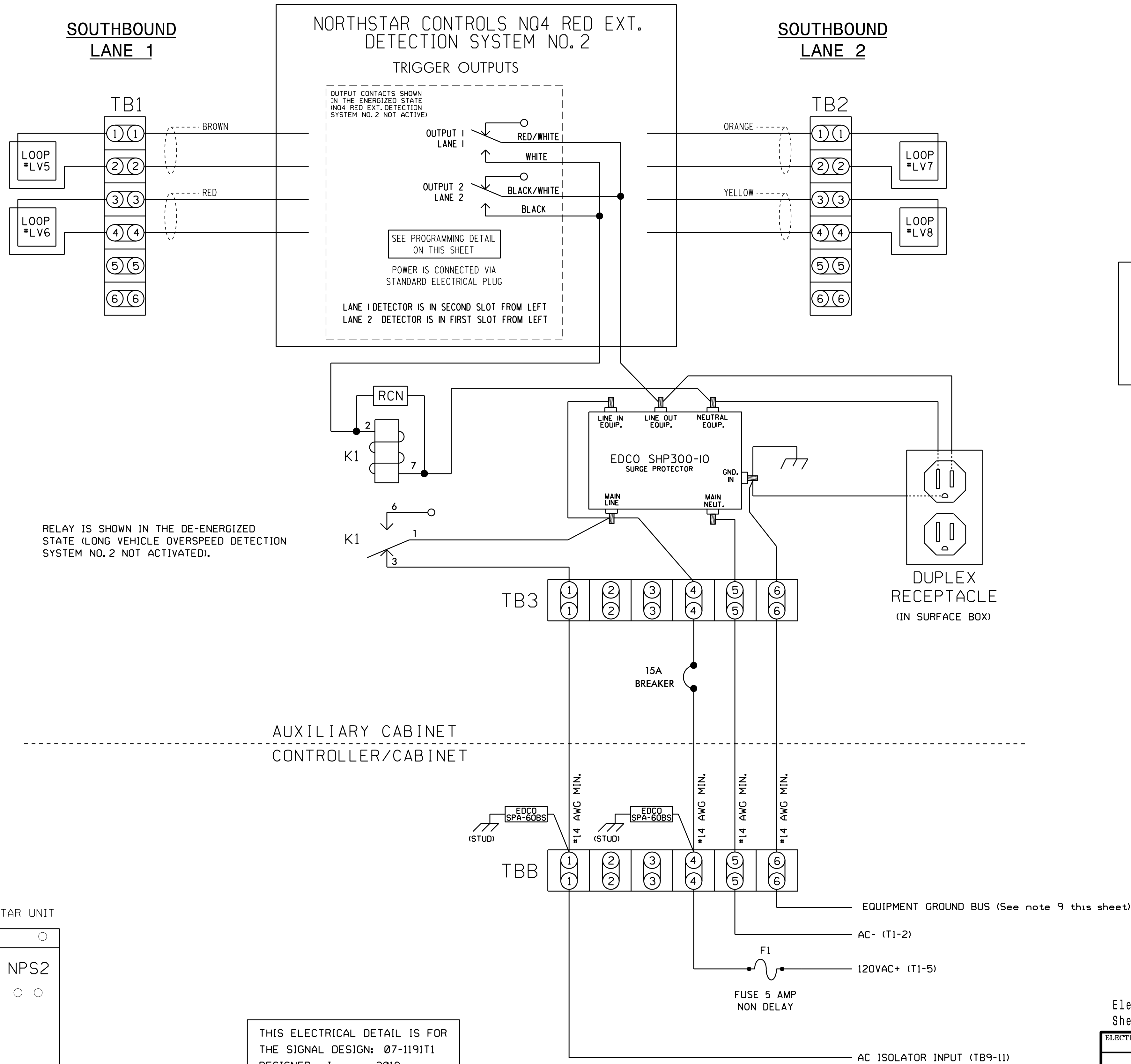

RELAY IS SHOWN IN THE DE-ENERGIZED STATE (LONG VEHICLE OVERSPEED DETECTION SYSTEM NO. 2 NOT ACTIVATED).

THIS ELECTRICAL DETAIL IS FOR THE SIGNAL DESIGN: 07-1191T1
 DESIGNED: January 2018
 SEALED: 2/7/2018
 REVISED: N/A

NORTHSTAR CONTROLS MODEL NQ4 PROGRAMMING DETAIL

(program unit as shown below)

NOTE: Unit must be programmed using a PC and a terminal emulator program. For connection to the terminal emulator, refer to the NQ4 operation manual.

- Program the NQ4 by typing the following commands:
1. SET SPEED = 55
 2. SET LENGTH = 22'
 3. SET ALARMTIME = 12
 4. SET SEPARATION = 16' (leading edge to leading edge - program actual measured separation)
 5. SET LOOP LENGTH = 6' (program actual measured loop length)
 6. SAVE

FRONT VIEW OF NORTHSTAR UNIT

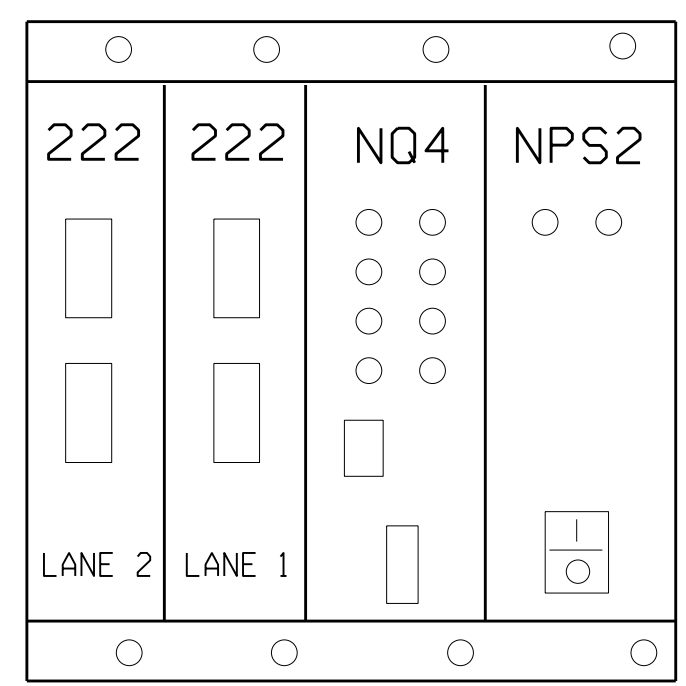

Electrical Detail - Temporary Design 1 (TMP Phase I)
 Sheet 8 of 8

ELECTRICAL AND PROGRAMMING DETAILS FOR: Prepared In the Offices of: S.A. Transportation Mobility and Safety Division STATE OF NORTH CAROLINA Department of Transportation Signal Management Section 750 N. Greenfield Pkwy, Garner, NC 27529	I-85 Bus. / US 29-70 at SR 1144 (River Road)		DOCUMENT NOT CONSIDERED FINAL UNLESS ALL SIGNATURES COMPLETED SEAL KEITH M. MIMS ENGINEER 2/8/2018 DATE
	Division 7 PLAN DATE: February 2018 PREPARED BY: S. Armstrong	Guilford County REVIEWED BY: REVIEWED BY:	

08-FEB-2018 11:10
 S:\MITSAS\115_Signal\work\hgr\cous\sig_Mph\armstrong071191_sm_elec_xxx.dgn
 sarmstrong