

**NOTES**

STIRRUPS IN CAP MAY BE SHIFTED AS NECESSARY TO CLEAR DOWELS.

THE CONCRETE IN THE SHADED AREA OF THE WING SHALL BE POURED AFTER THE VERTICAL CONCRETE BARRIER RAIL IS CAST IF SLIP FORMING IS USED.

FOR PILE SPLICE DETAILS, SEE SHEET 4 OF 4.

FOR WING DETAILS, SEE SHEET 3 OF 4.

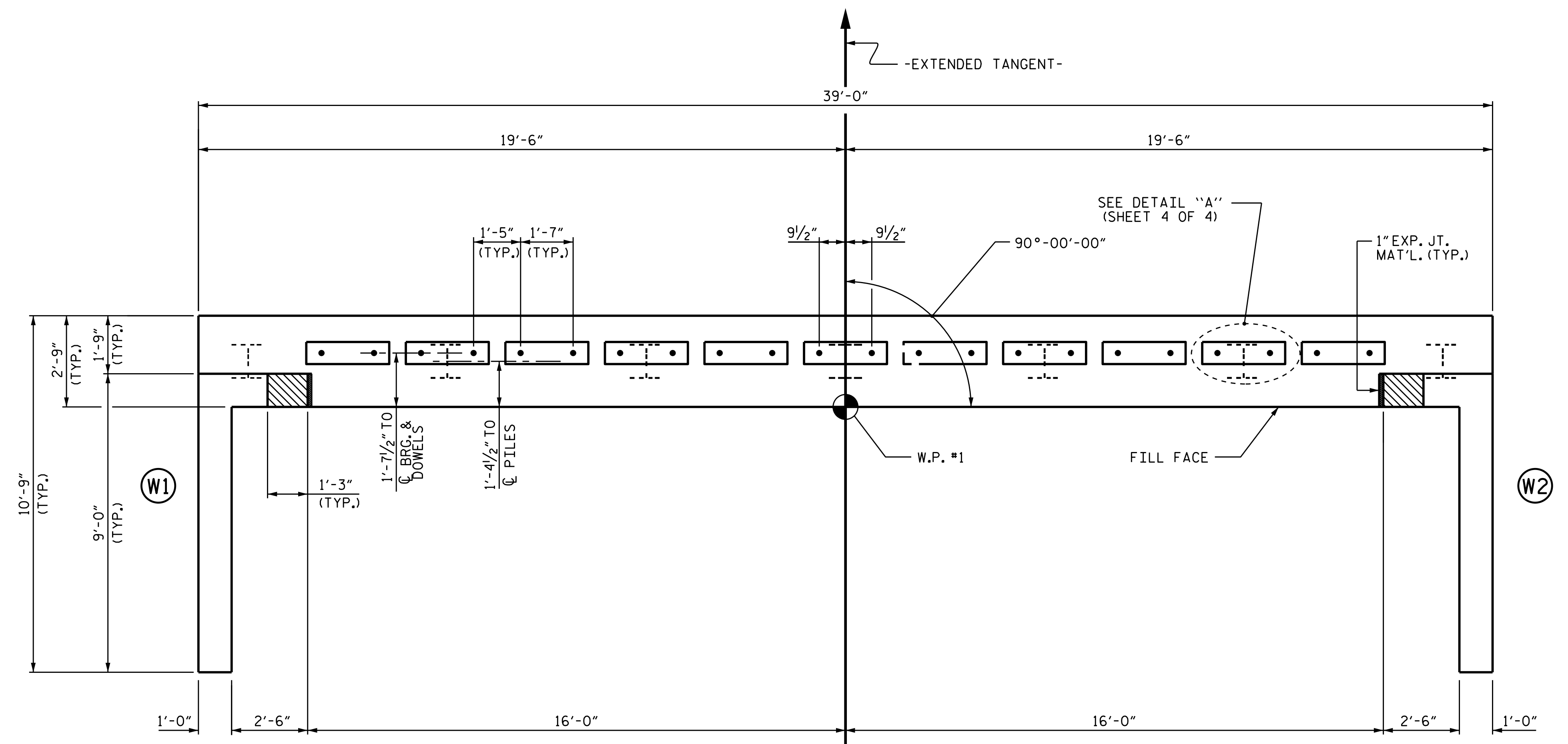

**PLAN**

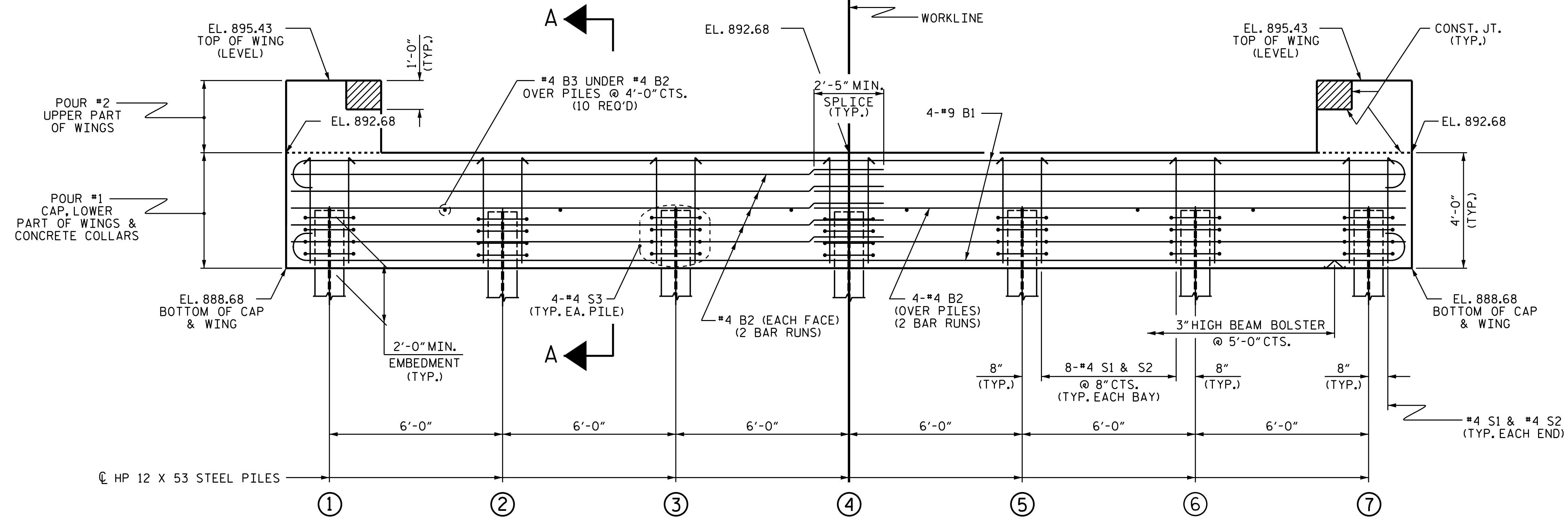

**ELEVATION**

WINGS NOT SHOWN FOR CLARITY.  
 FOR SECTION A-A, SEE SHEET 4 OF 4.  
 CONCRETE COLLARS FOR STEEL PILES NOT SHOWN IN PLAN AND ELEVATION VIEWS FOR CLARITY.  
 SEE "CORROSION PROTECTION FOR STEEL PILES DETAIL", SHEET 4 OF 4.

PROJECT NO. B-5407  
POLK COUNTY  
 STATION: 13+52.00 -L-

SHEET 1 OF 4

STATE OF NORTH CAROLINA  
 DEPARTMENT OF TRANSPORTATION  
 RALEIGH

**SUBSTRUCTURE  
 END BENT 1**

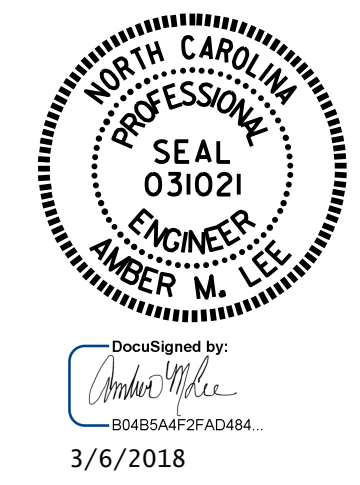

ASSEMBLED BY : A. GODFREY	DATE : 10/2017
CHECKED BY : G. KOUCHEKI	DATE : 12/2017
DRAWN BY : WJH	12/11
CHECKED BY : AAC	12/11
REV. 4/15	MAA/TMG

DOCUMENT NOT CONSIDERED FINAL UNLESS ALL SIGNATURES COMPLETED

REVISIONS						SHEET NO.
NO.	BY:	DATE:	NO.	BY:	DATE:	S-16
1			3			TOTAL SHEETS 24
2			4			