

NOTES

STIRRUPS IN CAP MAY BE SHIFTED AS NECESSARY TO CLEAR DOWELS.

THE CONCRETE IN THE SHADED AREA OF THE WING SHALL BE POURED AFTER THE VERTICAL CONCRETE BARRIER RAIL IS CAST IF SLIP FORMING IS USED.

FOR PILE SPLICE DETAILS, SEE SHEET 4 OF 4.

FOR WING DETAILS, SEE SHEET 3 OF 4.

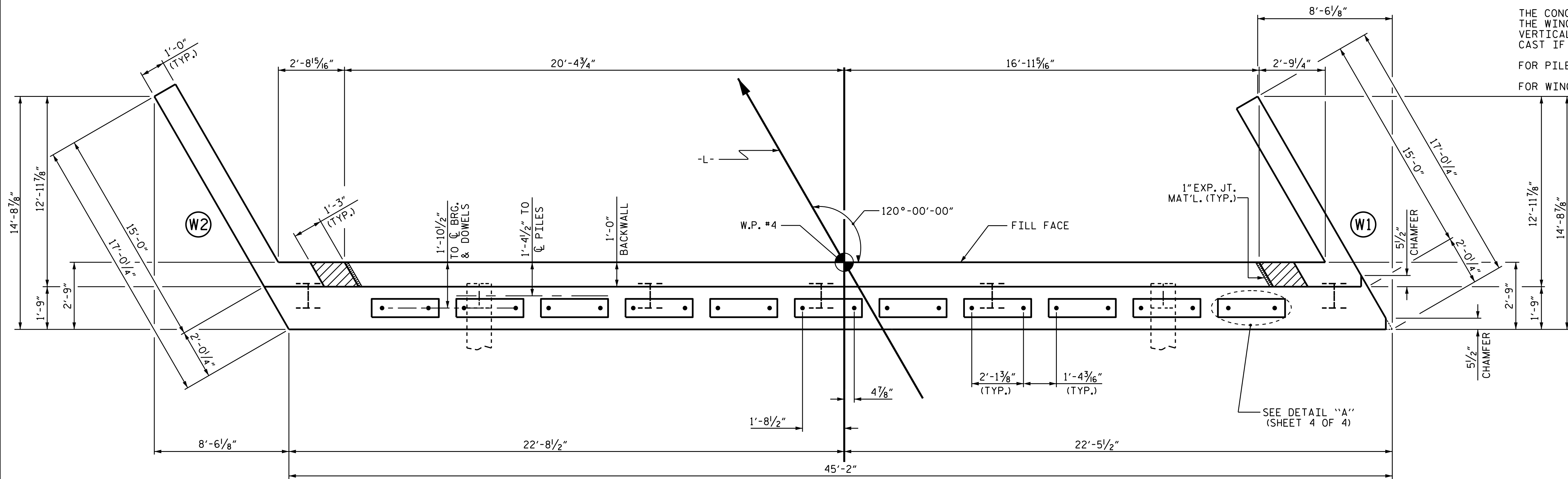

PLAN

TOP OF PILE ELEVATIONS	
①	384.57
②	384.75
③	384.92
④	385.09
⑤	385.27
⑥	385.44
⑦	385.61

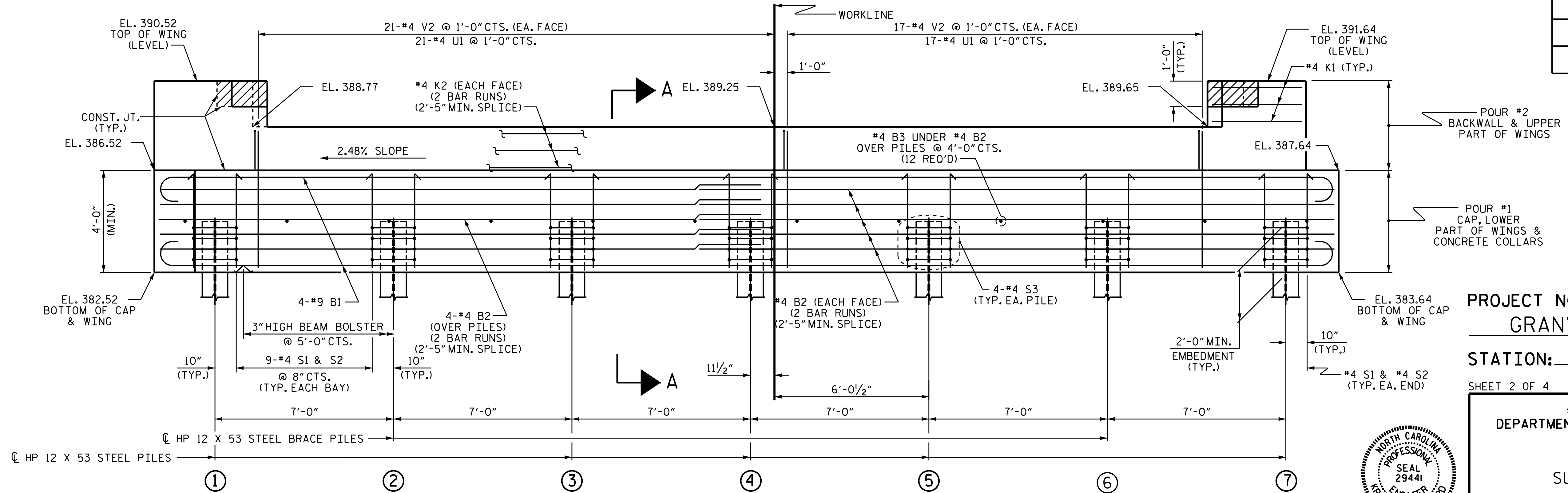

ELEVATION

PROJECT NO. B-5320
GRANVILLE COUNTY
 STATION: 15+98.00 -L-

SHEET 2 OF 4

STATE OF NORTH CAROLINA
 DEPARTMENT OF TRANSPORTATION
 RALEIGH

SUBSTRUCTURE
 END BENT No. 2

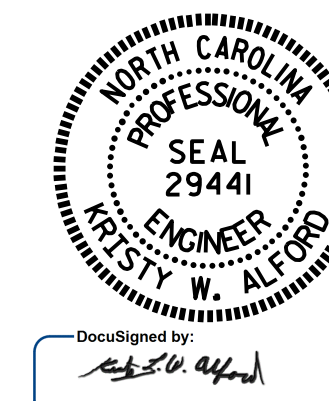

WINGS NOT SHOWN FOR CLARITY.
 FOR SECTION A-A, SEE SHEET 4 OF 4.
 CONCRETE COLLARS FOR STEEL PILES NOT SHOWN IN PLAN AND ELEVATION VIEWS FOR CLARITY.
 SEE "CORROSION PROTECTION FOR STEEL PILES DETAIL", SHEET 4 OF 4.

DOCUMENT NOT CONSIDERED
 FINAL UNLESS ALL
 SIGNATURES COMPLETED

REVISIONS		SHEET NO.	
NO.	DATE	NO.	DATE
1		3	
2		4	
		S-18	
		TOTAL SHEETS 26	

ASSEMBLED BY : M. A. LESHURE	DATE : 1/18
CHECKED BY : K. W. ALFORD	DATE : 2/18
DRAWN BY : WJH	12/11
CHECKED BY : AAC	12/11
	REV. 4/15 MAA/TMG