

HITCH SHAFT ASSEMBLY
SCALE: 1 1/2"=1'-0"

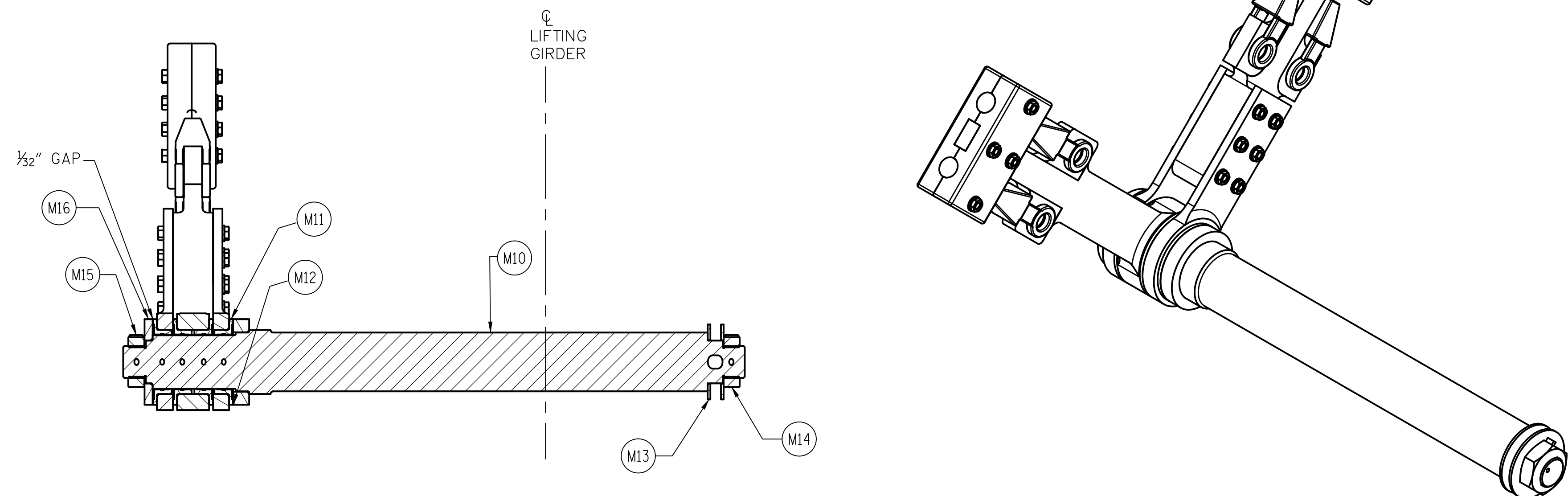

SECTION A-A
SCALE: 1 1/2"=1'-0"

NOTES:

1. ALL COMPONENTS TO BE NEW EXCEPT FOR THE HITCH ARMS.

BILL OF MATERIALS



ITEM NO.	QTY.	DESCRIPTION	MATERIAL/MANUFACTURER
M10	2	NEW HITCH SHAFT	STEEL, ASTM A291, CLASS 3 OR ASTM A311 GR. 4140 COLD DRAWN
M11	8	NEW HITCH SHAFT BUSHING	BRONZE, ASTM B22 ALLOY C91100
M12	2	NEW HITCH THRUST COLLAR	STEEL, ASTM A311 GR. 1045, HOT ROLLED
M13	4	NEW SHIM	STAINLESS, ASTM A240 TYPE 316
M14	4	NEW LOCK NUT WITH SS COTTER PIN	STEEL, ASTM A563, GR. 18-8 COTTER
M15	2	NEW THRUST WASHER	STEEL, ASTM A36

PROJECT NO. 15BPR.15
NEW HANOVER COUNTY
 STATION: _____

LAST SAVED 1/24/2018 4:27 PM BY EASAMPLE
 LAST PLOTTED 1/29/2018 10:29 AM
 FILE: \\imiddo01\projects\1682\01\CADD\Mechanical\MA-6 AUX. COUNTERWEIGHT ASSEMBLY DETAILS - 4

DESIGNED BY:	E. A. SAMPLE	DATE :	08/17/17
DRAWN BY:	J. M. SHOUP	DATE :	08/17/17
CHECKED BY:	L. R. LENTZ	DATE :	01/25/18
DESIGN ENGINEER OF RECORD:	L. R. LENTZ	DATE :	01/25/18

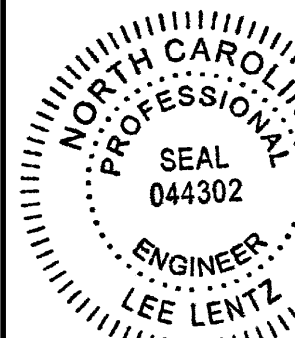
MODJESKI and MASTERS
 Experience great bridges.
 333 FAYETTEVILLE STREET, SUITE 505
 RALEIGH, NC 27601
 NC LICENSE NO. C-2979

 NORTH CAROLINA
 PROFESSIONAL
 SEAL
 044302
 ENGINEER
 LEE LENTZ
 01/29/18
 DocuSigned by:

 286C7C8EBBF64C8

STATE OF NORTH CAROLINA
 DEPARTMENT OF TRANSPORTATION
 RALEIGH

**AUX. COUNTERWEIGHT
 ASSEMBLY DETAILS - 4**

REVISIONS						SHEET NO.
NO.	BY:	DATE:	NO.	BY:	DATE:	MA-6
1			3			TOTAL SHEETS
2			4			10(A)

**DOCUMENT NOT CONSIDERED FINAL
UNLESS ALL SIGNATURES COMPLETED**