

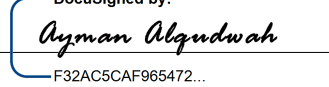

**This electronic collection of documents is provided  
for the convenience of the user  
and is Not a Certified Document –**

**The documents contained herein were originally issued  
and sealed by the individuals whose names and license  
numbers appear on each page, on the dates appearing  
with their signature on that page.**

**This file or an individual page  
shall not be considered a certified document.**

TIP NO. U-3334B	SHEET NO. PMP-1
APPROVED:  <small>DocuSigned by: Ayman Alqudwah</small> <small>135A2C3CAF98472</small>	
DATE: 10/10/2017	
SEAL 	
DOCUMENT NOT CONSIDERED FINAL UNLESS ALL SIGNATURES COMPLETED	

**STATE OF NORTH CAROLINA  
DEPARTMENT OF TRANSPORTATION**

**PAVEMENT MARKING PLAN  
JOHNSTON COUNTY**

**LOCATION: SR 1923 EXTENSION (BOOKER DAIRY RD) FROM SR 1003  
(BUFFALO RD) TO US 301 (BRIGHTLEAF BLVD)**

**T.I.P.: U-3334B**

**CONTRACT: C204060**

**ROADWAY STANDARD DRAWING**

THE FOLLOWING ROADWAY STANDARDS AS APPEAR IN "ROADWAY STANDARD DRAWINGS" - PROJECT SERVICES UNIT - N.C. DEPARTMENT OF TRANSPORTATION - RALEIGH, N.C., DATED JANUARY 2018 ARE APPLICABLE TO THIS PROJECT AND BY REFERENCE HEREBY ARE CONSIDERED A PART OF THESE PLANS:

STD. NO.	TITLE
1205.01	PAVEMENT MARKINGS - LINE TYPES AND OFFSETS
1205.02	PAVEMENT MARKINGS - TWO-LANE AND MULTILANE ROADWAYS
1205.04	PAVEMENT MARKINGS - INTERSECTIONS
1205.05	PAVEMENT MARKINGS - TURN LANES
1205.06	PAVEMENT MARKINGS - LANE DROPS
1205.07	PAVEMENT MARKINGS - PEDESTRIAN CROSSWALKS
1205.08	PAVEMENT MARKINGS - SYMBOLS AND WORD MESSAGES
1205.09	PAVEMENT MARKINGS - PAINTED ISLANDS
1205.10	PAVEMENT MARKINGS - SCHOOL AREAS
1205.13	PAVEMENT MARKINGS - LANE REDUCTIONS
1205.15	PAVEMENT MARKINGS - SUPERSTREETS
1250.01	RAISED PAVEMENT MARKERS - INSTALLATION SPACING
1251.01	RAISED PAVEMENT MARKERS - PERMANENT AND TEMPORARY
1261.01	GUARDRAIL AND BARRIER DELINEATORS - INSTALLATION SPACING
1261.02	GUARDRAIL AND BARRIER DELINEATORS - TYPES AND MOUNTING
1262.01	GUARDRAIL END DELINEATION
1264.01	OBJECT MARKERS - TYPES
1264.02	OBJECT MARKERS - INSTALLATION

**GENERAL NOTES**

THE FOLLOWING GENERAL NOTES APPLY AT ALL TIMES FOR THE DURATION OF THE CONSTRUCTION PROJECT, EXCEPT WHEN OTHERWISE NOTED IN THE PLAN, OR DIRECTED BY THE ENGINEER.

- A) INSTALL PAVEMENT MARKINGS AND PAVEMENT MARKERS ON THE FINAL SURFACE AS FOLLOWS:
 

ROAD NAME	MARKING	MARKER
L, L_TIE, Y1, Y2, Y2A, Y3, Y4, Y5, Y6, Y7, Y8	THERMOPLASTIC	PERMANENT RAISED
- B) TIE PROPOSED PAVEMENT MARKING LINES TO EXISTING PAVEMENT MARKING LINES.
- C) REMOVE/REPLACE ANY CONFLICTING/DAMAGED PAVEMENT MARKINGS AND MARKERS.
- D) PASSING ZONES WILL BE DETERMINED IN THE FIELD AND MUST BE APPROVED BY THE ENGINEER.
- E) STOP BAR LOCATION AT NON-SIGNALIZED INTERSECTIONS MAY BE ADJUSTED AS DIRECTED BY THE ENGINEER.
- F) UNLESS OTHERWISE SPECIFIED, HEATED-IN-PLACE THERMOPLASTIC MAY BE USED IN LIEU OF EXTRUDED THERMOPLASTIC FOR STOP BARS, SYMBOLS, CHARACTERS AND DIAGONALS. IF HEATED-IN-PLACE IS USED, IT SHALL BE PAID FOR USING THE EXTRUDED THERMOPLASTIC PAY ITEM.
- G) SEE ROADWAY PLANS FOR ALTERNATE CURB RAMP DESIGNS WHEN INDICATED ON PAVEMENT MARKING DETAIL SHEETS.

**INDEX**

SHEET NO.	DESCRIPTION
PMP-1	PAVEMENT MARKING PLAN TITLE AND NOTES
PMP-2	FINAL PAVEMENT MARKINGS SCHEDULE
PMP-3 thru 8	PAVEMENT MARKING DETAIL

PLAN PREPARED BY: N.C.D.O.T. SIGNING AND DELINEATION UNIT

**A.I.ALQUDWAH, PE** SIGNING & DELINEATION REGIONAL ENGINEER  
**D.M.EATON, PE** SIGNING & DELINEATION PROJECT DESIGN ENGINEER/TECHNICIAN

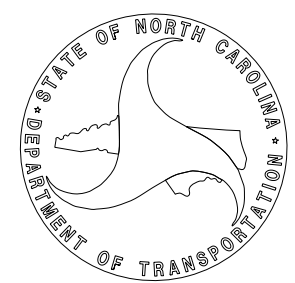

\$\$\$ SYSTEM \$\$\$  
 \$\$\$ US \$\$\$  
 \$\$\$ DLENAME \$\$\$  
 \$\$\$ \$\$\$

**FINAL PAVEMENT MARKINGS**

THERMOPLASTIC(24", 120 MILS)  
T2 WHITE STOPBAR

THERMOPLASTIC(8", 120 MILS)  
TQ WHITE CROSSWALK LINE

THERMOPLASTIC(4", 120 MILS)

T8	2 FT. - 6 FT./SP WHITE MINISKIP
T9	2 FT. - 6 FT./SP YELLOW MINISKIP
TC	10 FT. WHITE SKIP
TD	3 FT. - 9 FT./SP WHITE MINISKIP
TE	WHITE SOLID LANE LINE
TF	10 FT. YELLOW SKIP
TH	YELLOW SINGLE CENTER
TI	YELLOW DOUBLE CENTER

THERMOPLASTIC(12", 90 MILS)  
TU WHITE DIAGONAL  
TV YELLOW DIAGONAL







THERMOPLASTIC(8", 90 MILS)  
TN WHITE GORELINE

THERMOPLASTIC(4", 90 MILS)  
TA WHITE EDGELINE  
TB YELLOW EDGELINE

**PERMANENT RAISED MARKERS**

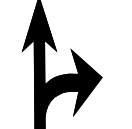
YELLOW & YELLOW  
CRYSTAL & RED

**FINAL PAVEMENT MARKING SYMBOLS AND CHARACTERS**

-  UA LEFT TURN ARROW (90 MILS)
-  UB RIGHT TURN ARROW (90 MILS)
-  UC STRAIGHT ARROW (90 MILS)
-  UE COMBO. STRAIGHT/RIGHT (90 MILS)
-  UP MERGE ARROW (90 MILS)
-  WD COMBO. LEFT/U-TURN (90 MILS)
-  SCHOOL UI ALPHANUMERIC (120 MILS) CHARACTER
-  ONLY UI ALPHANUMERIC (120 MILS) CHARACTER

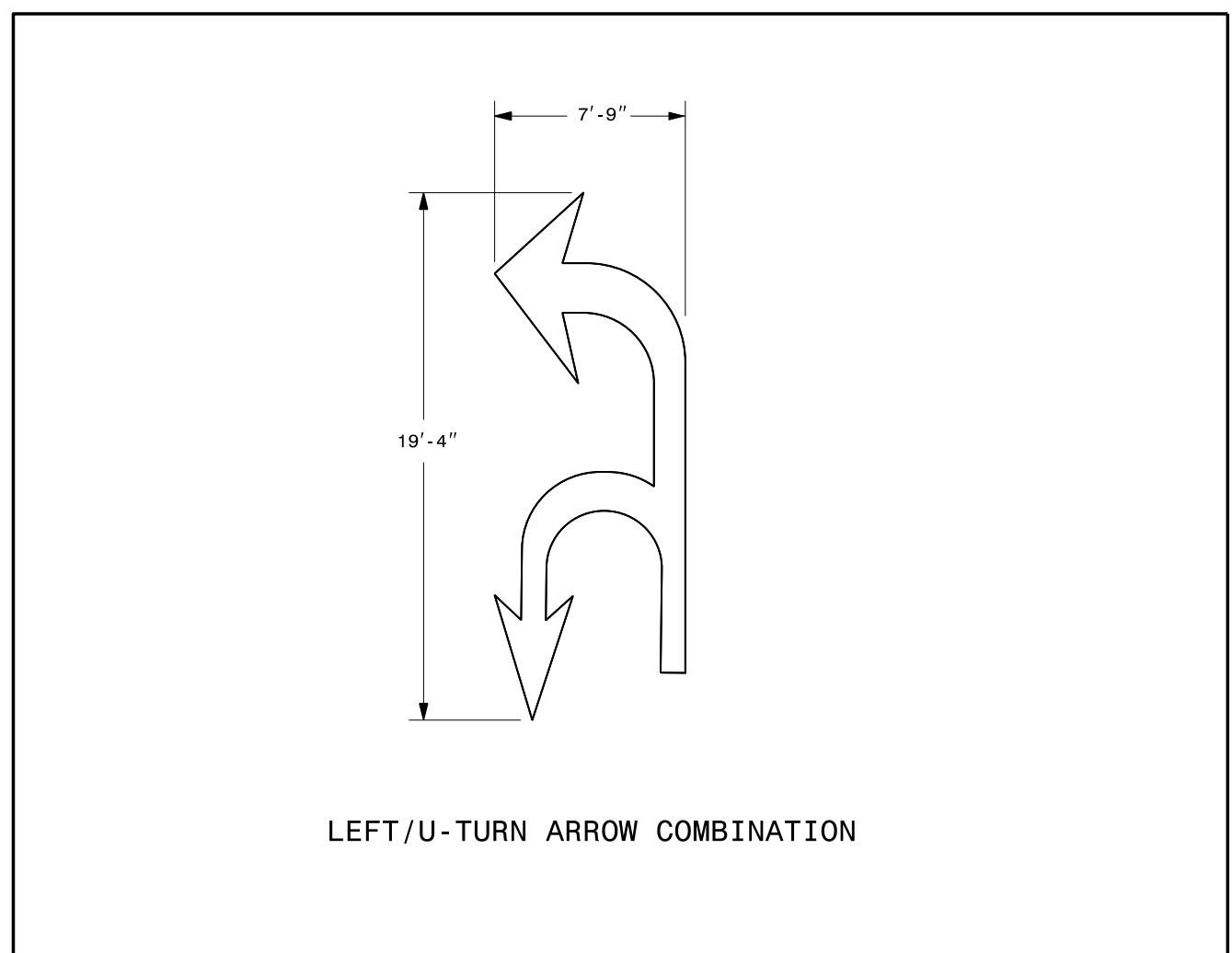

\$\$\$\$\$SYTIME\$\$\$\$\$  
\$\$\$\$\$BDGN\$\$\$\$\$  
\$\$\$\$\$USERNAIVE\$\$\$\$\$



APPROVED: *Ayman Alqudwah*  
 DATE: 10/10/2017



DOCUMENT NOT CONSIDERED FINAL UNLESS ALL SIGNATURES COMPLETED

CURB RAMPS	
①	STD. TYPE, -L- STA. 28+54+/- (61' LT)
②	TYPE 3, -L- STA. 28+25+/- (67.5' RT)

NAD 83/NSRS 2007

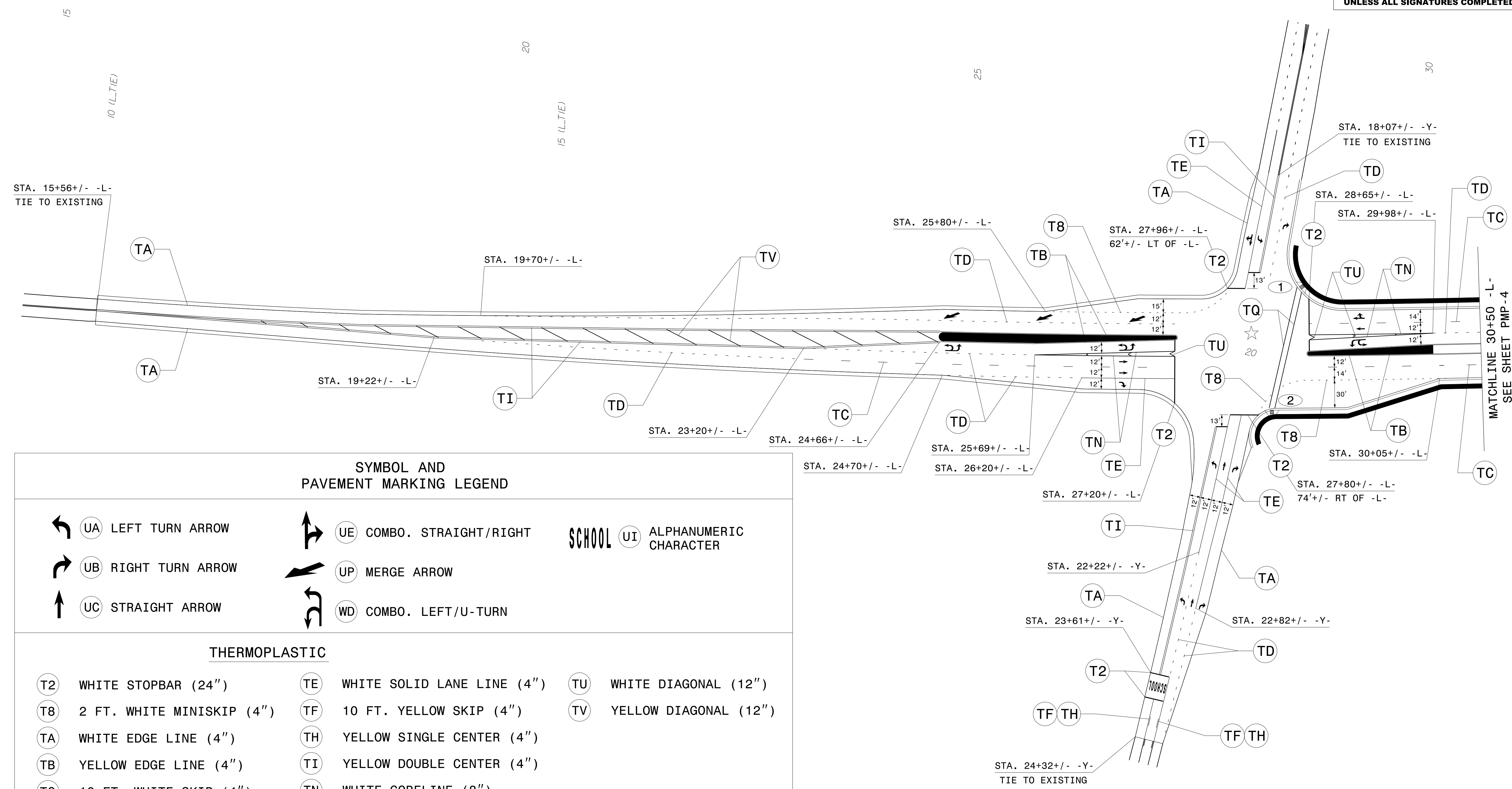

SYMBOL AND PAVEMENT MARKING LEGEND

UA LEFT TURN ARROW	UE COMBO. STRAIGHT/RIGHT	SCHOOL  UI ALPHANUMERIC CHARACTER
UB RIGHT TURN ARROW	UP MERGE ARROW	
UC STRAIGHT ARROW	WD COMBO. LEFT/U-TURN	

THERMOPLASTIC

T2 WHITE STOPBAR (24")	TE WHITE SOLID LANE LINE (4")	TU WHITE DIAGONAL (12")
T8 2 FT. WHITE MINISKIP (4")	TF 10 FT. YELLOW SKIP (4")	TV YELLOW DIAGONAL (12")
TA WHITE EDGE LINE (4")	TH YELLOW SINGLE CENTER (4")	
TB YELLOW EDGE LINE (4")	TI YELLOW DOUBLE CENTER (4")	
TC 10 FT. WHITE SKIP (4")	TN WHITE GORELINE (8")	
TD 3 FT. WHITE MINISKIP (4")	TQ WHITE CROSSWALK (8")	

PROPOSED PAVEMENT MARKINGS

\*\*\*\*\*SYTIME\*\*\*\*\*  
 \*\*\*\*\*CDN\*\*\*\*\*  
 \*\*\*\*\*USERNAME\*\*\*\*\*  
 \*\*\*\*\*P\*\*\*\*\*

NAD 83/NRS 2007

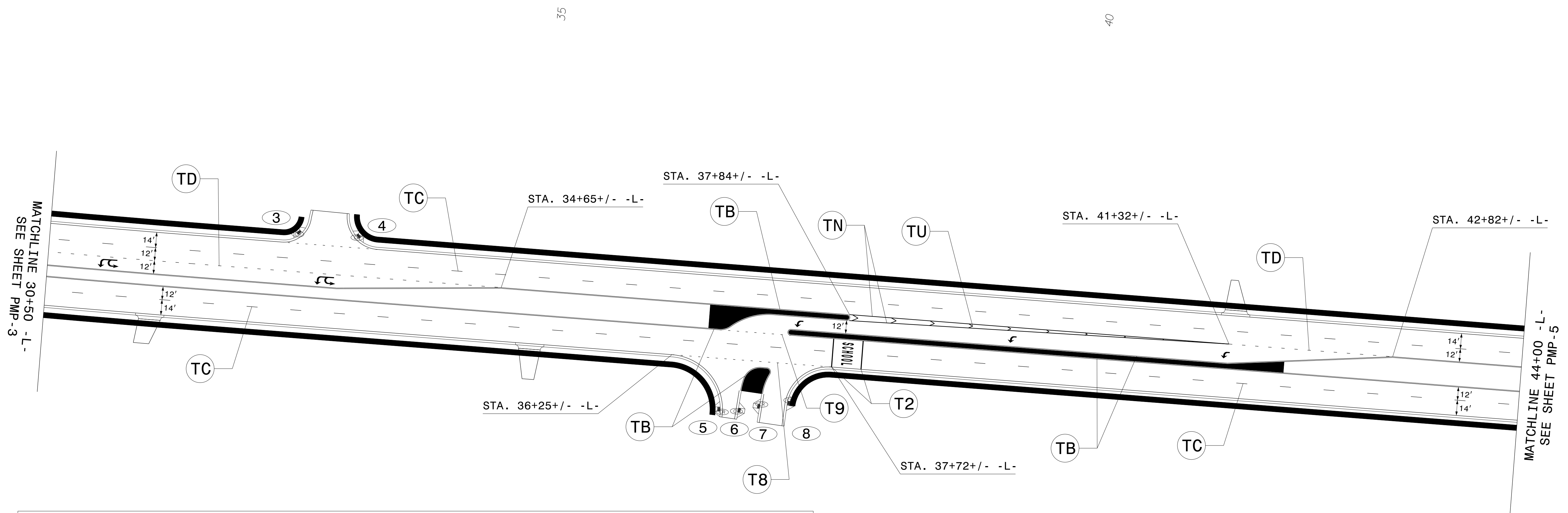

SYMBOL AND PAVEMENT MARKING LEGEND			
	UA	LEFT TURN ARROW	
	UI	ALPHANUMERIC CHARACTER	
	WD	COMBO. LEFT/U-TURN	
THERMOPLASTIC			
	T2	WHITE STOPBAR (24")	
	TC	10 FT. WHITE SKIP (4")	
	T8	2 FT. WHITE MINISKIP (4")	
	TD	3 FT. WHITE MINISKIP (4")	
	T9	2 FT. YELLOW MINISKIP (4")	
	TN	WHITE GORELINE (8")	
	TU	WHITE DIAGONAL (12")	
	TB	YELLOW EDGE LINE (4")	

CURB RAMPS	
	STD. TYPE, -L- STA. 32+80+/- (44.9' LT)
	STD. TYPE, -L- STA. 33+29+/- (45.9' LT)
	STD. TYPE, -L- STA. 36+75+/- (83.6' RT)
	STD. TYPE, -L- STA. 36+87+/- (83.5' RT)
	STD. TYPE, -L- STA. 37+11+/- (78.6' RT)
	STD. TYPE, -L- STA. 37+32+/- (73.5' RT)

PROPOSED PAVEMENT MARKINGS

SYSTEMS  
USER NAME  
DATE





APPROVED: *Ayman Alqudwah*  
Professional Engineer License No. F32ACSCAF96472  
 DATE: 10/10/2017

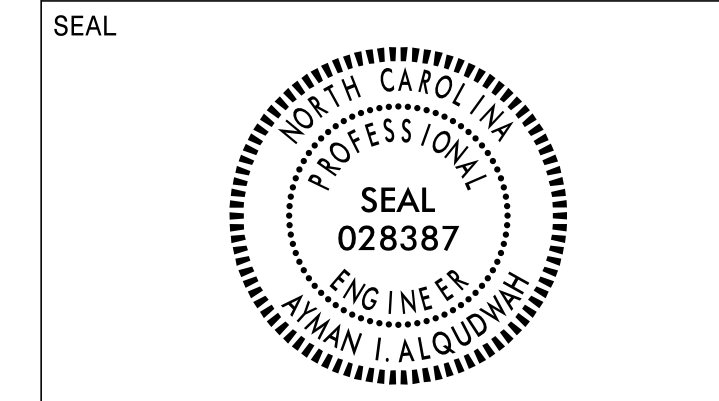

DOCUMENT NOT CONSIDERED FINAL  
 UNLESS ALL SIGNATURES COMPLETED

CURB RAMPS	
15	STD. TYPE, -L- STA. 58+32+/- (46' LT)
16	STD. TYPE, -L- STA. 59+14+/- (55.7' LT)
17	STD. TYPE, -L- STA. 58+31+/- (41.7' RT)
18	STD. TYPE, -L- STA. 59+15+/- (43' RT)
19	TYPE 3, -L- STA. 66+82+/- (67.5' LT)
20	STD. TYPE, -L- STA. 67+20+/- (76' LT)
21	STD. TYPE, -L- STA. 66+83+/- (42.6' RT)
22	STD. TYPE, -L- STA. 67+07+/- (67' RT)

NAD 83/NSRS 2007

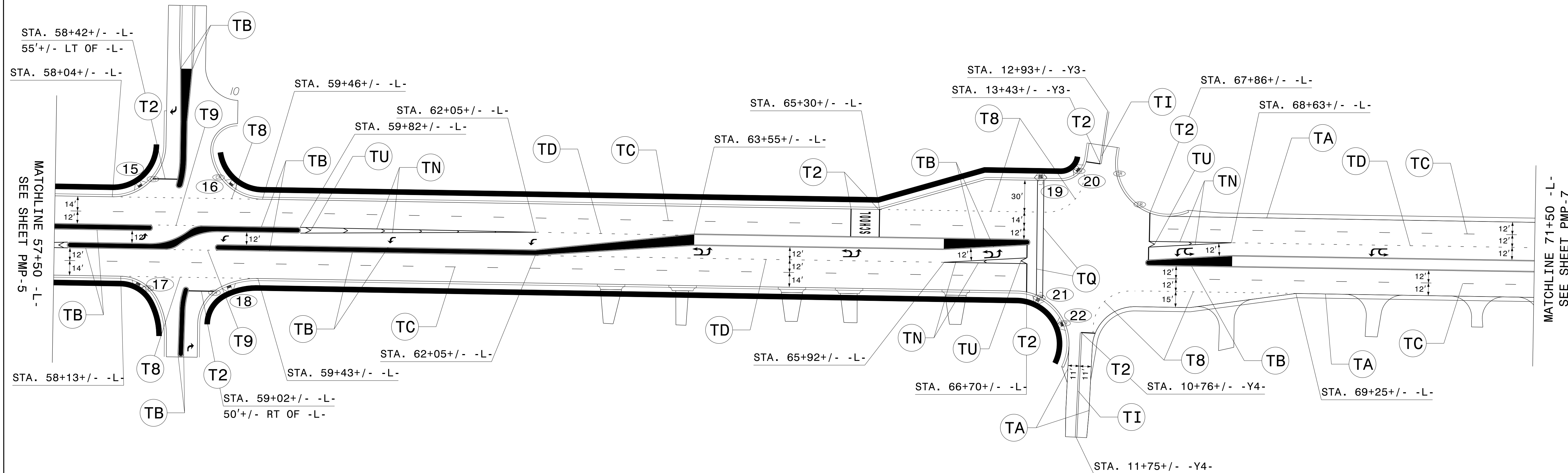

SYMBOL AND PAVEMENT MARKING LEGEND		
UA LEFT TURN ARROW	UB RIGHT TURN ARROW	SCHOOL UI ALPHANUMERIC CHARACTER
<b>THERMOPLASTIC</b>		
T2 WHITE STOPBAR (24")	TA WHITE EDGE LINE (4")	TI DOUBLE YELLOW CENTER (4")
T3 WHITE CROSSWALK LINE (24")	TB YELLOW EDGE LINE (4")	TN WHITE GORELINE (8")
T8 2 FT. WHITE MINISKIP (4")	TC 10 FT. WHITE SKIP (4")	TQ WHITE CROSSWALK LINE (8")
T9 2 FT. YELLOW MINISKIP (4")	TD 3 FT. WHITE MINISKIP (4")	TU WHITE DIAGONAL (12")

PROPOSED PAVEMENT MARKINGS

SYSTEM TIME: 10/10/2017 10:10:17 AM  
 USER: AALQUDWAH  
 PROJECT: U-3334B

APPROVED: *Ayman Alqudwah*  
Professional Engineer  
 DATE: 10/10/2017



DOCUMENT NOT CONSIDERED FINAL  
 UNLESS ALL SIGNATURES COMPLETED

NAD 83/NSRS 2007

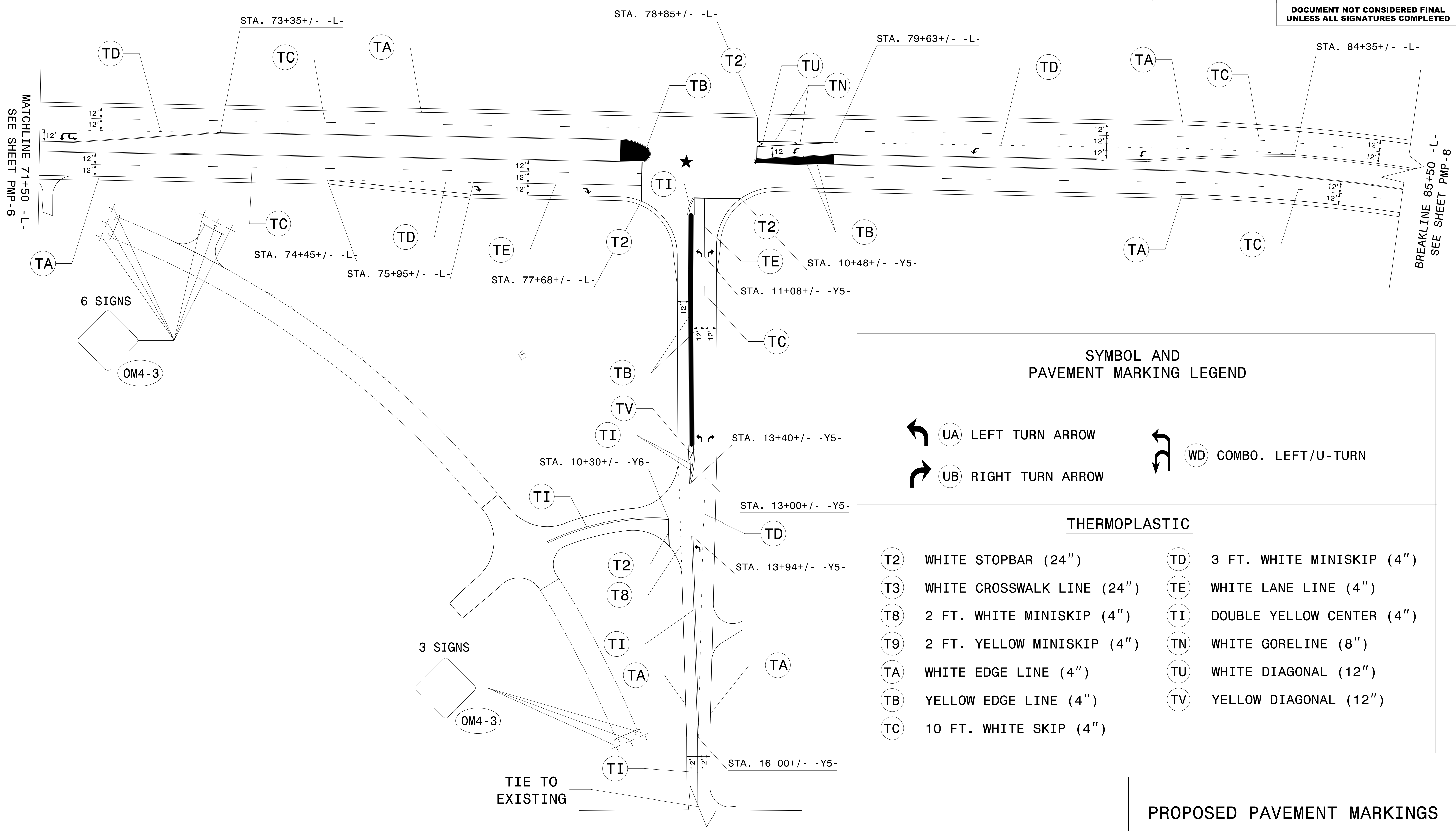

SYMBOL AND PAVEMENT MARKING LEGEND			
	UA	LEFT TURN ARROW	
	UB	RIGHT TURN ARROW	
	WD	COMBO. LEFT/U-TURN	
THERMOPLASTIC			
T2	WHITE STOPBAR (24")	TD	3 FT. WHITE MINISKIP (4")
T3	WHITE CROSSWALK LINE (24")	TE	WHITE LANE LINE (4")
T8	2 FT. WHITE MINISKIP (4")	TI	DOUBLE YELLOW CENTER (4")
T9	2 FT. YELLOW MINISKIP (4")	TN	WHITE GORELINE (8")
TA	WHITE EDGE LINE (4")	TU	WHITE DIAGONAL (12")
TB	YELLOW EDGE LINE (4")	TV	YELLOW DIAGONAL (12")
TC	10 FT. WHITE SKIP (4")		

PROPOSED PAVEMENT MARKINGS

\$\$\$\$\$SYTIME\$\$\$\$\$  
 \$\$\$CDN\$\$\$\$\$  
 \$\$\$USERNAME\$\$\$\$\$



