

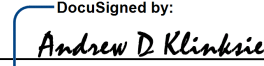

**This electronic collection of documents is provided
for the convenience of the user
and is Not a Certified Document –**

**The documents contained herein were originally issued
and sealed by the individuals whose names and license
numbers appear on each page, on the dates appearing
with their signature on that page.**

**This file or an individual page
shall not be considered a certified document.**

TIP NO. R-2707F	SHEET NO. PMP-1
APPROVED:  <small>DocuSigned by: Andrew D. Klinksiak E3078FB4596E44B</small>	
DATE: 10/17/2017	
	
DOCUMENT NOT CONSIDERED FINAL UNLESS ALL SIGNATURES COMPLETED	

**STATE OF NORTH CAROLINA
DEPARTMENT OF TRANSPORTATION**

**PAVEMENT MARKING PLAN
CLEVELAND COUNTY**

T.I.P.: R-2707F

CONTRACT: C203845

INDEX

SHEET NO.	DESCRIPTION
PMP-1	PAVEMENT MARKING PLAN COVER SHEET
PMP-2	FINAL PAVEMENT MARKING SCHEDULE AND LEGEND
PMP-3 THRU PMP-23	PAVEMENT MARKING DETAIL

GENERAL NOTES

THE FOLLOWING GENERAL NOTES APPLY AT ALL TIMES FOR THE DURATION OF THE CONSTRUCTION PROJECT, EXCEPT WHEN OTHERWISE NOTED IN THE PLAN, OR DIRECTED BY THE ENGINEER.

A) INSTALL PAVEMENT MARKINGS AND PAVEMENT MARKERS ON THE FINAL SURFACE AS FOLLOWS:

ROAD NAME	MARKING	MARKER
-L- FUTURE US 74, ALL LOOPS AND RAMPS	POLYUREA (HIGHLY REFLECTIVE MEDIA)	SNOWPLOWABLE
-L- BRIDGES	POLYUREA (HIGHLY REFLECTIVE MEDIA)	RAISED
ALL -Y- LINES	THERMOPLASTIC	SNOWPLOWABLE
ALL -Y- LINE BRIDGES	COLD-APPLIED PLASTIC	RAISED

- B) SIX-INCH WIDE MARKINGS INCLUDING BUT NOT LIMITED TO LANE LINES, EDGE LINES AND SKIPS SHALL BE USED ON ALL US ROUTES WITH CONTROLLED ACCESS.
- C) USE HEATED-IN-PLACE THERMOPLASTIC OR EXTRUDED THERMOPLASTIC MARKINGS FOR STOP BARS, SYMBOLS, CHARACTERS AND DIAGONALS.
- D) REMOVE ALL RESIDUE AND SURFACE LAITANCE BY WATER BLASTING OR GRINDING ON BRIDGE DECK(S) PRIOR TO PLACING POLYUREA PAVEMENT MARKINGS.
- E) TIE PROPOSED PAVEMENT MARKING LINES TO EXISTING PAVEMENT MARKING LINES.
- F) PASSING ZONE(S) WILL BE DETERMINED IN THE FIELD AND MUST BE APPROVED BY THE ENGINEER.
- G) MARKERS SHALL BE INSTALLED ACCORDING TO THE NCDOT ROADWAY STANDARD DRAWING 1250.01.
- H) STOPBARS AT NON-SIGNALIZED INTERSECTIONS MAY BE ADJUSTED AS DIRECTED BY THE ENGINEER.

ROADWAY STANDARD DRAWING

THE FOLLOWING ROADWAY STANDARDS AS APPEAR IN "ROADWAY STANDARD DRAWINGS" - PROJECT SERVICES UNIT - N.C. DEPARTMENT OF TRANSPORTATION - RALEIGH, N.C., DATED JANUARY 2018 ARE APPLICABLE TO THIS PROJECT AND BY REFERENCE HEREBY ARE CONSIDERED A PART OF THESE PLANS:

STD. NO.	TITLE
1205.01	PAVEMENT MARKINGS - LINE TYPES AND OFFSETS
1205.02	PAVEMENT MARKINGS - TWO-LANE AND MULTILANE ROADWAYS
1205.03	PAVEMENT MARKINGS - EXIT AND ENTRANCE RAMPS
1205.04	PAVEMENT MARKINGS - INTERSECTIONS
1205.05	PAVEMENT MARKINGS - TURN LANES
1205.06	PAVEMENT MARKINGS - LANE DROPS
1205.08	PAVEMENT MARKINGS - SYMBOLS AND WORD MESSAGES
1205.09	PAVEMENT MARKINGS - PAINTED ISLANDS
1205.12	PAVEMENT MARKINGS - BRIDGES
1205.13	PAVEMENT MARKINGS - LANE REDUCTIONS
1250.01	RAISED PAVEMENT MARKERS - INSTALLATION SPACING
1251.01	RAISED PAVEMENT MARKERS - PERMANENT AND TEMPORARY
1253.01	RAISED PAVEMENT MARKERS - SNOWPLOWABLE
1261.01	GUARDRAIL AND BARRIER DELINEATORS - INSTALLATION SPACING
1261.02	GUARDRAIL AND BARRIER DELINEATORS - TYPES AND MOUNTING
1262.01	GUARDRAIL END DELINEATION
1264.01	OBJECT MARKERS - TYPES
1264.02	OBJECT MARKERS - INSTALLATION
1266.01	RAISED PAVEMENT MARKERS - TUBULAR MARKERS
1267.01	FLEXIBLE DELINEATORS - INSTALLATION
1267.02	FLEXIBLE DELINEATORS - SPACING TABLES
1267.03	FLEXIBLE DELINEATORS - INTERCHANGE PLACEMENT

PLAN REVIEWED BY: N.C.D.O.T. SIGNING AND DELINEATION UNIT

<u>Kelvin Jordan</u>	SIGNING & DELINEATION STANDARDS ENGINEER
<u>Bobby Navarrete</u>	SIGNING & DELINEATION PROJECT DESIGN ENGINEER

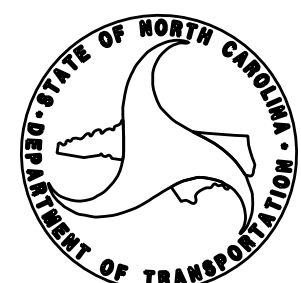

PLAN PREPARED BY: HNTB NORTH CAROLINA, P.C.

<u>A.D. Klinksiak, PE, PTOE</u>	PROJECT ENGINEER
<u>Matt DeBruyne</u>	DESIGN TECHNICIAN

HNTB HNTB NORTH CAROLINA, P.C.
343 E. Six Forks Road, Suite 200
Raleigh, North Carolina 27609
C-1554

TIP NO. R-2707F	SHEET NO. PMP-2
APPROVED: <u>Andrew D. Klinck</u> <small>DocuSigned by: E3D78FB4596E44B</small>	
DATE: 10/17/2017	
	
DOCUMENT NOT CONSIDERED FINAL UNLESS ALL SIGNATURES COMPLETED	

FINAL PAVEMENT MARKING SCHEDULE

MATERIAL	SYMBOL	DESCRIPTION
PAVEMENT MARKING		
<u>POLYUREA (6") Highly Reflective Elements</u>		
V6		WHITE EDGELINE
V7		YELLOW EDGELINE
VJ		10 FT. WHITE SKIP
VK		3 FT.- 9 FT./SP WHITE MINISKIP
VL		WHITE SOLID LANE LINE
<u>POLYUREA (12") Highly Reflective Elements</u>		
VS		WHITE GORELINE
VT		WHITE SOLID LANE LINE
<u>THERMOPLASTIC (8", 90 MILS)</u>		
TP		YELLOW DIAGONAL
<u>THERMOPLASTIC (12", 90 MILS)</u>		
TU		WHITE DIAGONAL
<u>THERMOPLASTIC (24", 120 MILS)</u>		
T2		WHITE STOPBAR
<u>THERMOPLASTIC (4", 120 MILS)</u>		
T8		2 FT.- 6 FT./SP WHITE MINISKIP
T9		2 FT.- 6 FT./SP YELLOW MINISKIP
TD		3 FT.- 9 FT./SP WHITE MINISKIP
TE		WHITE SOLID LANE LINE
TI		YELLOW DOUBLE CENTER
<u>THERMOPLASTIC (4", 90 MILS)</u>		
TA		WHITE EDGELINE
TB		YELLOW EDGELINE
<u>THERMOPLASTIC PAVEMENT MARKING SYMBOLS(90 MILS)</u>		
UA		LEFT TURN ARROW
UB		RIGHT TURN ARROW
UC		STRAIGHT ARROW
UF		COMBO LEFT/RIGHT ARROW
UP		MERGE ARROW
UQ		RAMP ARROW
YE		ELONGATED STRAIGHT ARROW
<u>PAINT (6")</u>		
P6		WHITE EDGELINE
P7		YELLOW EDGELINE
PK		3 FT.- 9 FT./SP WHITE MINISKIP
<u>PAINT (12")</u>		
PV		YELLOW DIAGONAL
<u>COLD APPLIED TYPE 3 (4")</u>		
CA		WHITE EDGELINE
CB		YELLOW EDGELINE
<u>COLD APPLIED TYPE 3 (8")</u>		
CP		YELLOW DIAGONAL

PERMANENT RAISED PAVEMENT MARKERS (NOT SHOWN)

MA	YELLOW & YELLOW
MB	CRYSTAL & RED

SNOWPLOWABLE PAVEMENT MARKERS (NOT SHOWN)

ME	YELLOW & YELLOW
MF	CRYSTAL & RED

LEGEND

- GENERAL**
- DIRECTION OF TRAFFIC FLOW
 - NORTH ARROW
 - PROPOSED PVMT. EXIST. PVMT.
 - TUBULAR MARKERS
- PAVEMENT MARKINGS**
- PAVEMENT MARKING SYMBOLS

PAVEMENT MARKING SYMBOLS

	UA
	UB
	UC
	UE
	UF
	UP
	UQ
	YE

10/17/2017
I:\PMP\R2707F_PMP_01-02.dgn
HNTB

HNTB HNTB NORTH CAROLINA, P.C.
343 E. SIX FORKS ROAD, SUITE 200
RALEIGH, NORTH CAROLINA 27609
NC LICENSE NO: C-1554
(919) 546-8997

PAVEMENT MARKING SCHEDULE AND LEGEND

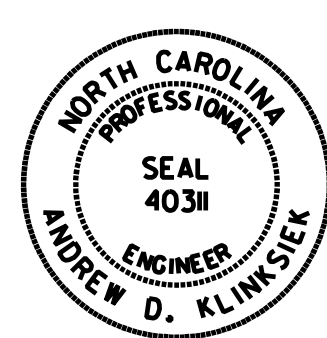
TIP NO. R-2707F	SHEET NO. PMP-3
APPROVED: <u>Andrew D. Klinck</u> <small>E3078F8459E448</small>	
DATE: 10/17/2017	
	
DOCUMENT NOT CONSIDERED FINAL UNLESS ALL SIGNATURES COMPLETED	

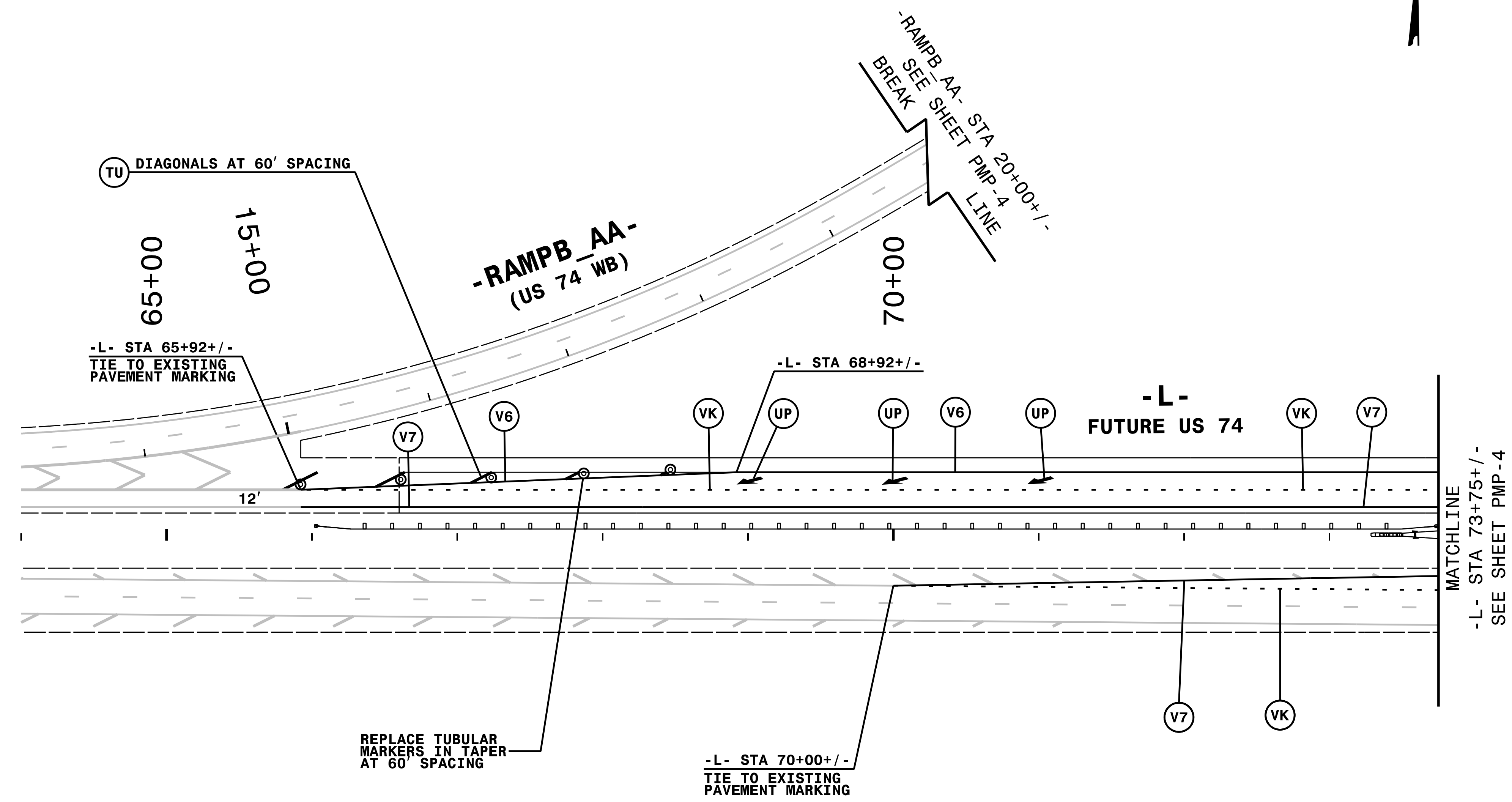

10/17/2017
\\hntb-gf11c\pmp\pmp\2707F_PMP_03.dgn
HNTB

NOTE: ALL LANE WIDTHS ARE 12' UNLESS OTHERWISE SHOWN.

HNTB HNTB NORTH CAROLINA, P.C.
343 E. SIX FORKS ROAD, SUITE 200
RALEIGH, NORTH CAROLINA 27609
NC LICENSE NO: C-1554
(919) 546-6997

PAVEMENT MARKING DETAIL

TIP NO. R-2707F	SHEET NO. PMP-4
APPROVED: <i>Andrew D. Klinck</i> E3D78F84596E44B	
DATE: 10/17/2017	
SEAL 	
DOCUMENT NOT CONSIDERED FINAL UNLESS ALL SIGNATURES COMPLETED	

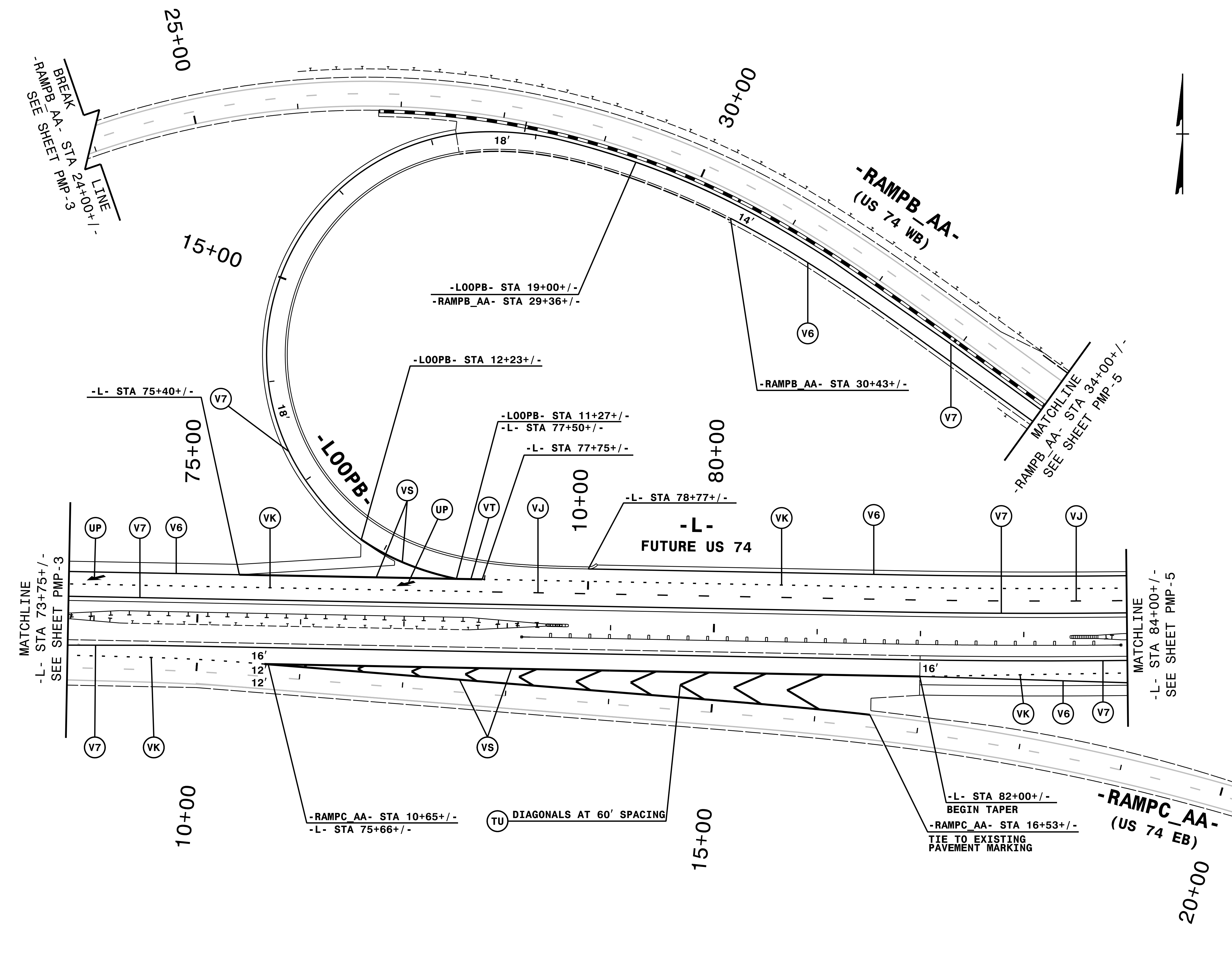

NOTE: ALL LANE WIDTHS ARE 12' UNLESS OTHERWISE SHOWN.

HNTB
 HNTB NORTH CAROLINA, P.C.
 343 E. SIX FORKS ROAD, SUITE 200
 RALEIGH, NORTH CAROLINA 27609
 NC LICENSE NO: C-1554
 (919) 546-8997

PAVEMENT MARKING DETAIL

10/17/2017
 \\T:\GFF\c\pmp\R2707F_PMP_04.dgn
 HNTB

TIP NO. R-2707F	SHEET NO. PMP-7
APPROVED: <i>Andrew D. Klinck</i> <small>DocuSigned by: E3D78FB4596E44B</small>	
DATE: 10/17/2017	
	
DOCUMENT NOT CONSIDERED FINAL UNLESS ALL SIGNATURES COMPLETED	

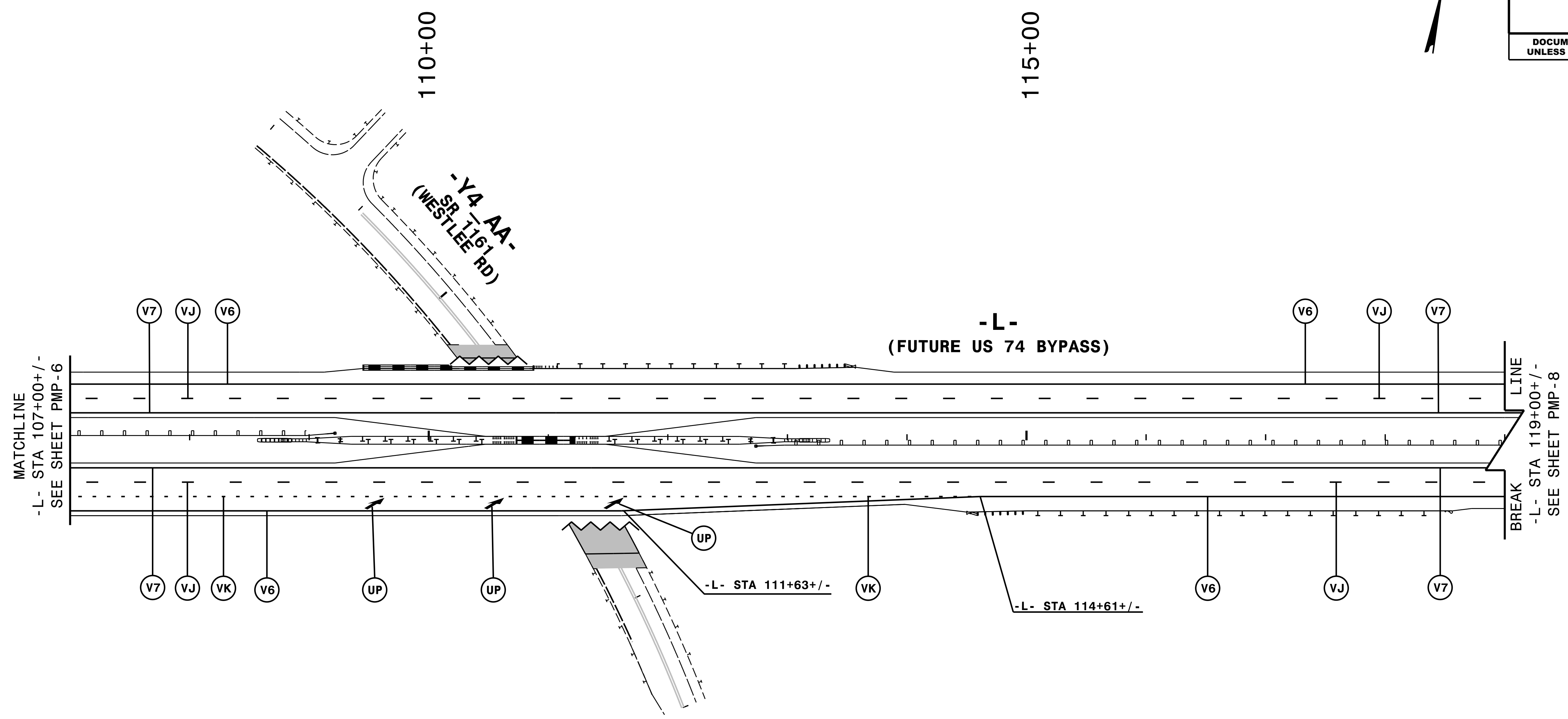
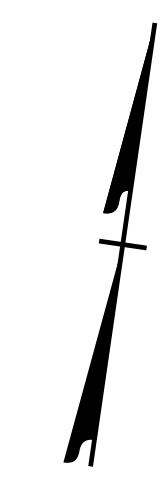

NOTE: ALL LANE WIDTHS ARE 12' UNLESS OTHERWISE SHOWN.

HNTB
HNTB NORTH CAROLINA, P.C.
 343 E. SIX FORKS ROAD, SUITE 200
 RALEIGH, NORTH CAROLINA 27609
 NC LICENSE NO: C-1554
 (919) 546-8997

PAVEMENT MARKING DETAIL

10/17/2017
 \\T:\G:\FFIC\PMR\R2707F_PMP_07.dgn
 HNTB

TIP NO. R-2707F	SHEET NO. PMP-8
APPROVED: <u>Andrew D. Klinck</u> <small>DocuSigned by: E3D78F84596E44B</small>	
DATE: 10/17/2017	
SEAL	
	
DOCUMENT NOT CONSIDERED FINAL UNLESS ALL SIGNATURES COMPLETED	

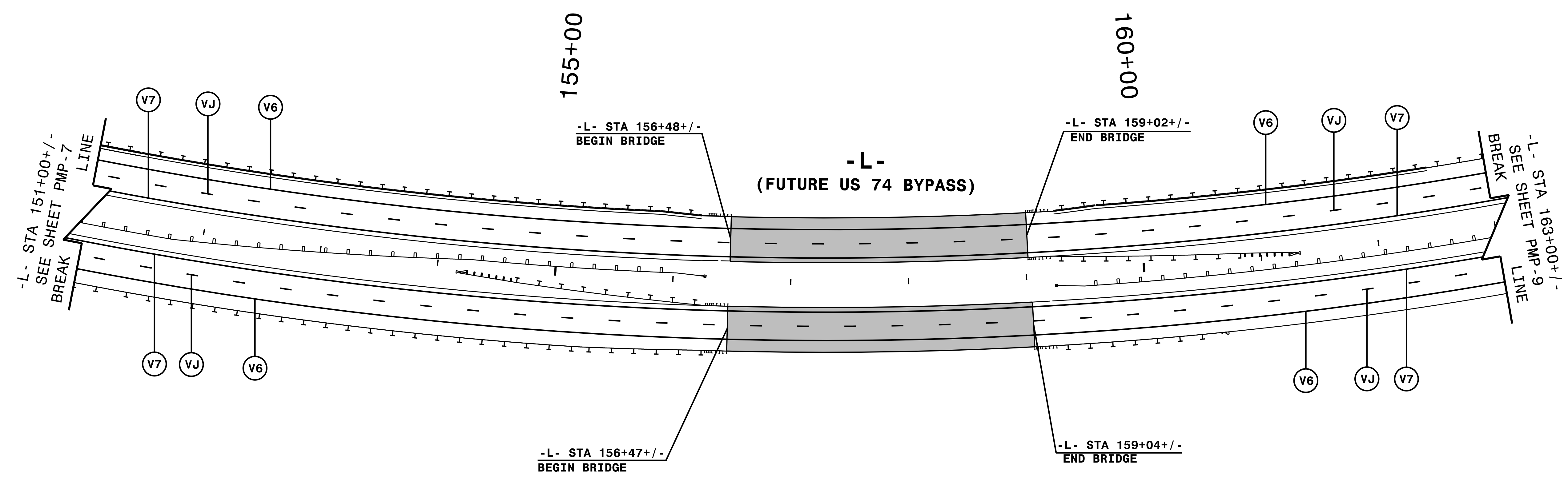
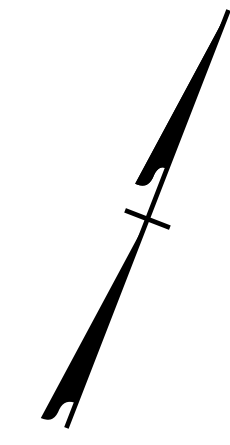

NOTE: ALL LANE WIDTHS ARE 12' UNLESS OTHERWISE SHOWN.

HNTB
 HNTB NORTH CAROLINA, P.C.
 343 E. SIX FORKS ROAD, SUITE 200
 RALEIGH, NORTH CAROLINA 27609
 NC LICENSE NO: C-1554
 (919) 546-8997

PAVEMENT MARKING DETAIL

10/17/2017
 \\T:\GFF\c\pmp\R2707F_PMP_08.dgn
 HNTB

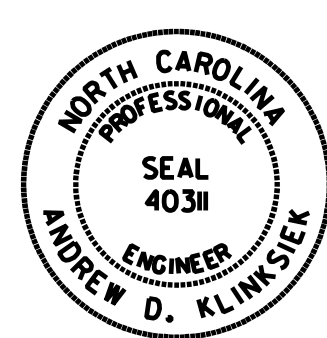
TIP NO. R-2707F	SHEET NO. PMP-10
APPROVED: <i>Andrew D. Klinck</i> <small>DocuSigned by: E3D78FB4596E448</small>	
DATE: 10/17/2017	
	
DOCUMENT NOT CONSIDERED FINAL UNLESS ALL SIGNATURES COMPLETED	

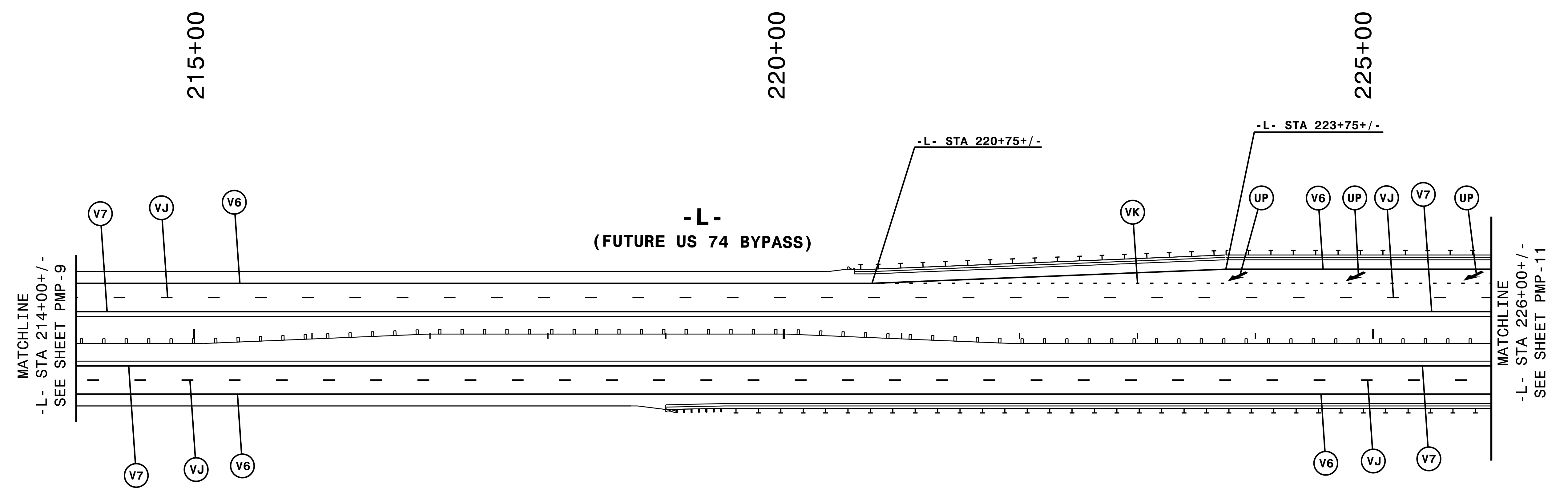
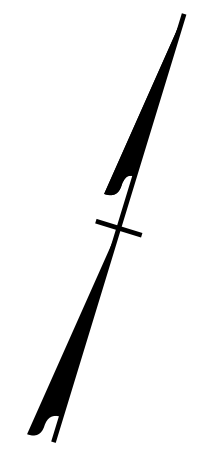

NOTE: ALL LANE WIDTHS ARE 12' UNLESS OTHERWISE SHOWN.

HNTB

HNTB NORTH CAROLINA, P.C.
343 E. SIX FORKS ROAD, SUITE 200
RALEIGH, NORTH CAROLINA 27609
NC LICENSE NO: C-1554
(919) 546-6997

PAVEMENT MARKING DETAIL

10/17/2017
I:\Projects\GTF\c\pmp\R2707F_PMP_10.dgn
HNTB

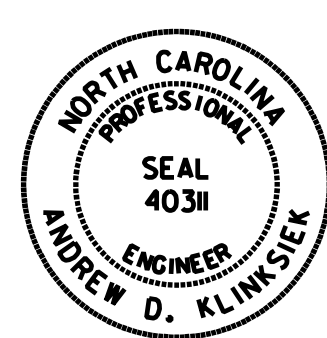
TIP NO. R-2707F	SHEET NO. PMP-11
APPROVED: <u>Andrew D. Klinck</u> <small>E3078FB4596E448</small>	
DATE: 10/17/2017	
	
DOCUMENT NOT CONSIDERED FINAL UNLESS ALL SIGNATURES COMPLETED	

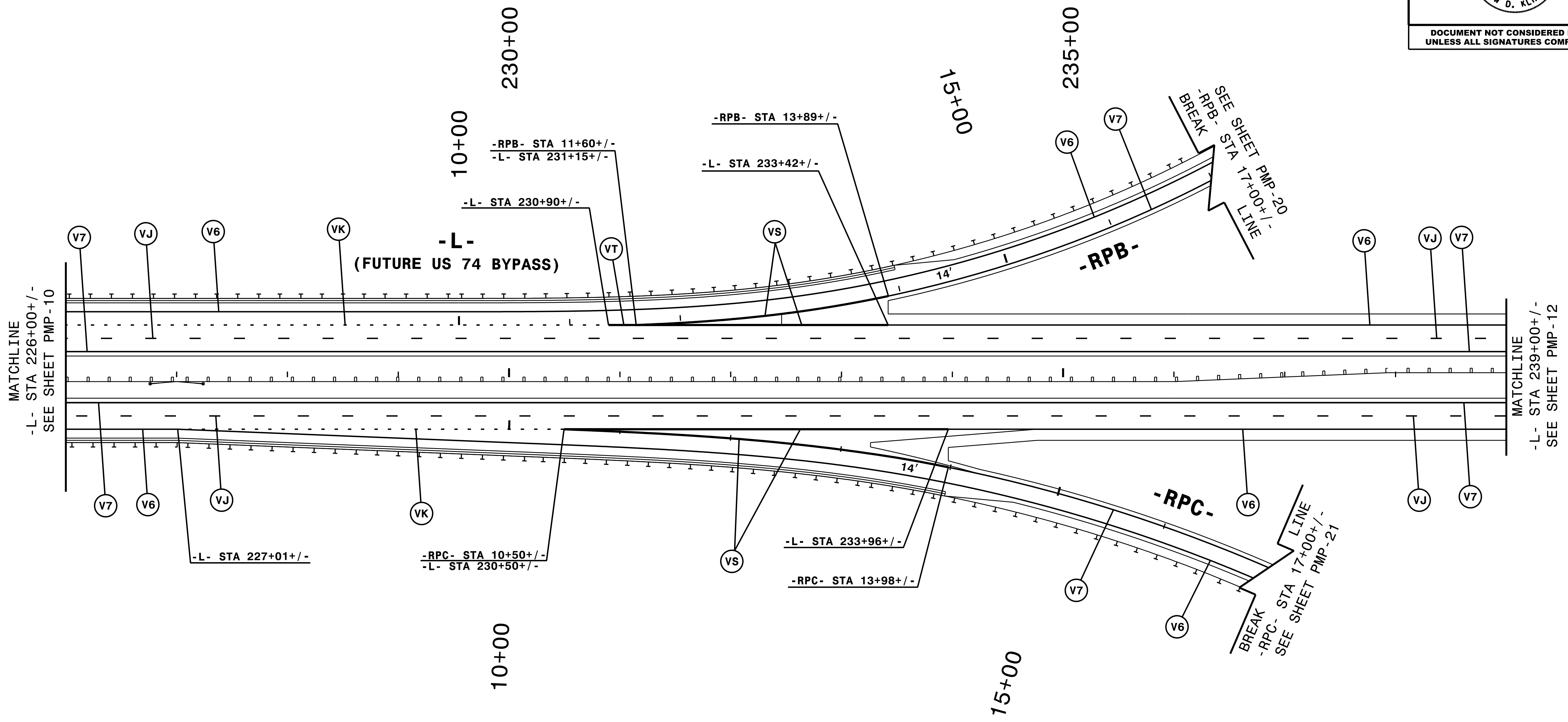
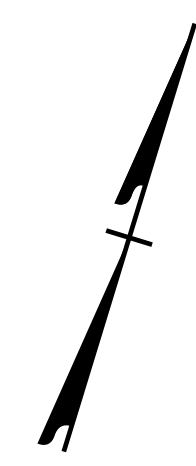

NOTE: ALL LANE WIDTHS ARE 12' UNLESS OTHERWISE SHOWN.

HNTB
HNTB NORTH CAROLINA, P.C.
 343 E. Six Forks Road, Suite 200
 Raleigh, North Carolina 27609
 NC License No: C-1554
 (919) 546-6997

PAVEMENT MARKING DETAIL

10/17/2017
 \\hntb-gff\c\pmp\2707F_PMP-11.dgn
 HNTB

TIP NO. R-2707F	SHEET NO. PMP-12
APPROVED: <u>Andrew D. Klinck</u> <small>DocuSigned by: E3D78F84566E44B</small>	
DATE: 10/17/2017	
	
DOCUMENT NOT CONSIDERED FINAL UNLESS ALL SIGNATURES COMPLETED	

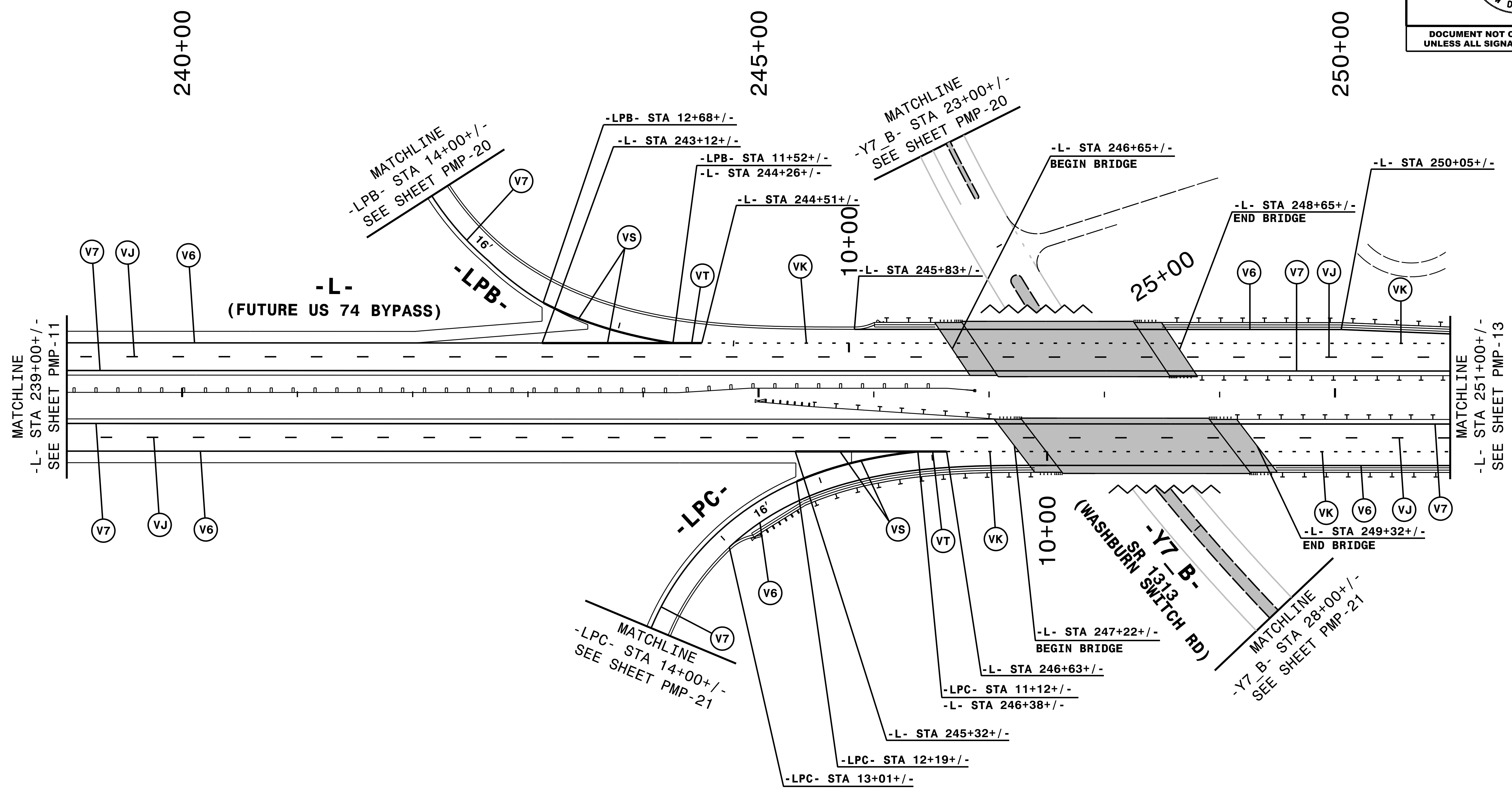

NOTE: ALL LANE WIDTHS ARE 12' UNLESS OTHERWISE SHOWN.

HNTB
HNTB NORTH CAROLINA, P.C.
 343 E. Six Forks Road, Suite 200
 Raleigh, North Carolina 27609
 NC License No: C-1554
 (919) 546-8997

PAVEMENT MARKING DETAIL

10/17/2017
 \\T:\G:\Office\PMR\R2707F_PMP_12.dgn
 HNTB

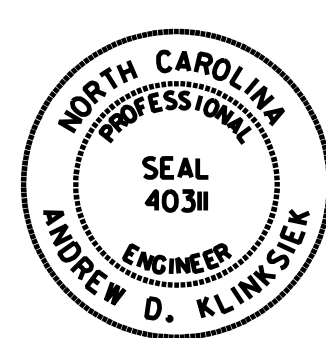
TIP NO. R-2707F	SHEET NO. PMP-14
APPROVED: <u>Andrew D. Klincksiek</u> <small>E3078FB4596E448</small>	
DATE: 10/17/2017	
	
DOCUMENT NOT CONSIDERED FINAL UNLESS ALL SIGNATURES COMPLETED	

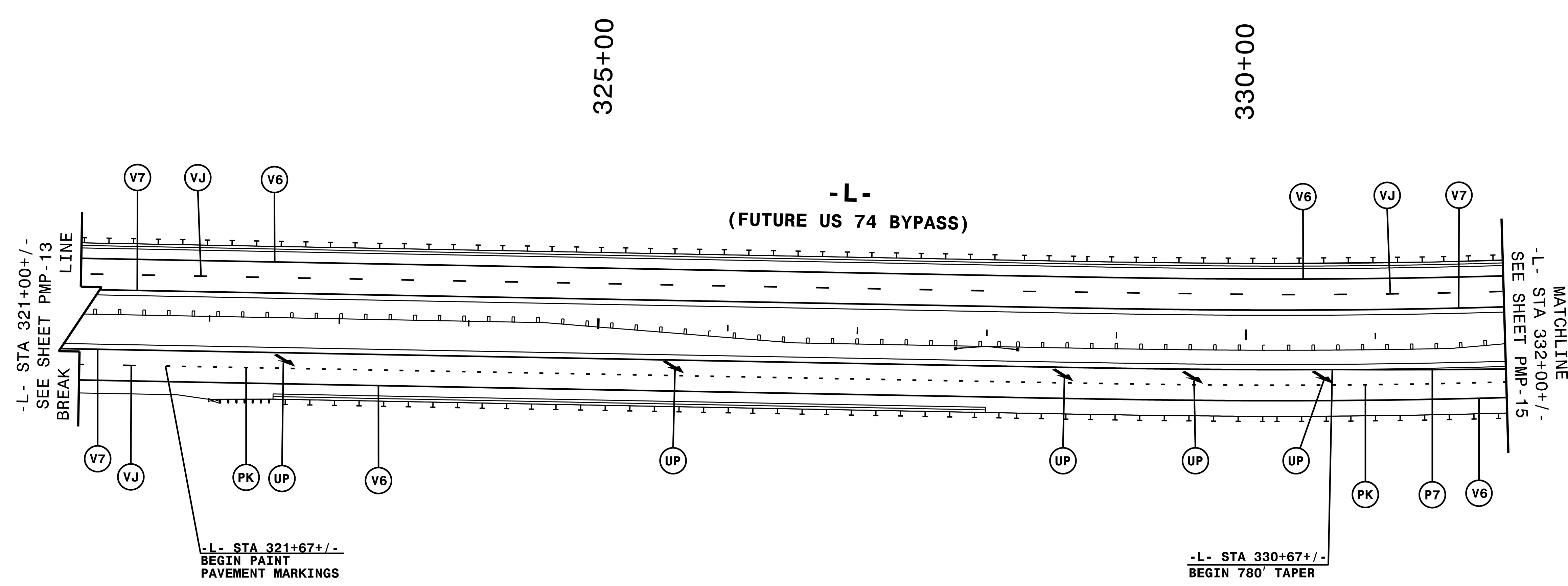

NOTE: ALL LANE WIDTHS ARE 12' UNLESS OTHERWISE SHOWN.

HNTB

HNTB NORTH CAROLINA, P.C.
343 E. SIX FORKS ROAD, SUITE 200
RALEIGH, NORTH CAROLINA 27609
NC LICENSE NO: C-1554
(919) 546-6997

PAVEMENT MARKING DETAIL

10/17/2017
\\hntb-gf1c1\pmp\R2707F_PMP_14.dgn
HNTB

TIP NO. R-2707F	SHEET NO. PMP-15
APPROVED: <i>Andrew D. Klinck</i> E3078FB459E448	
DATE: 10/17/2017	
	
DOCUMENT NOT CONSIDERED FINAL UNLESS ALL SIGNATURES COMPLETED	

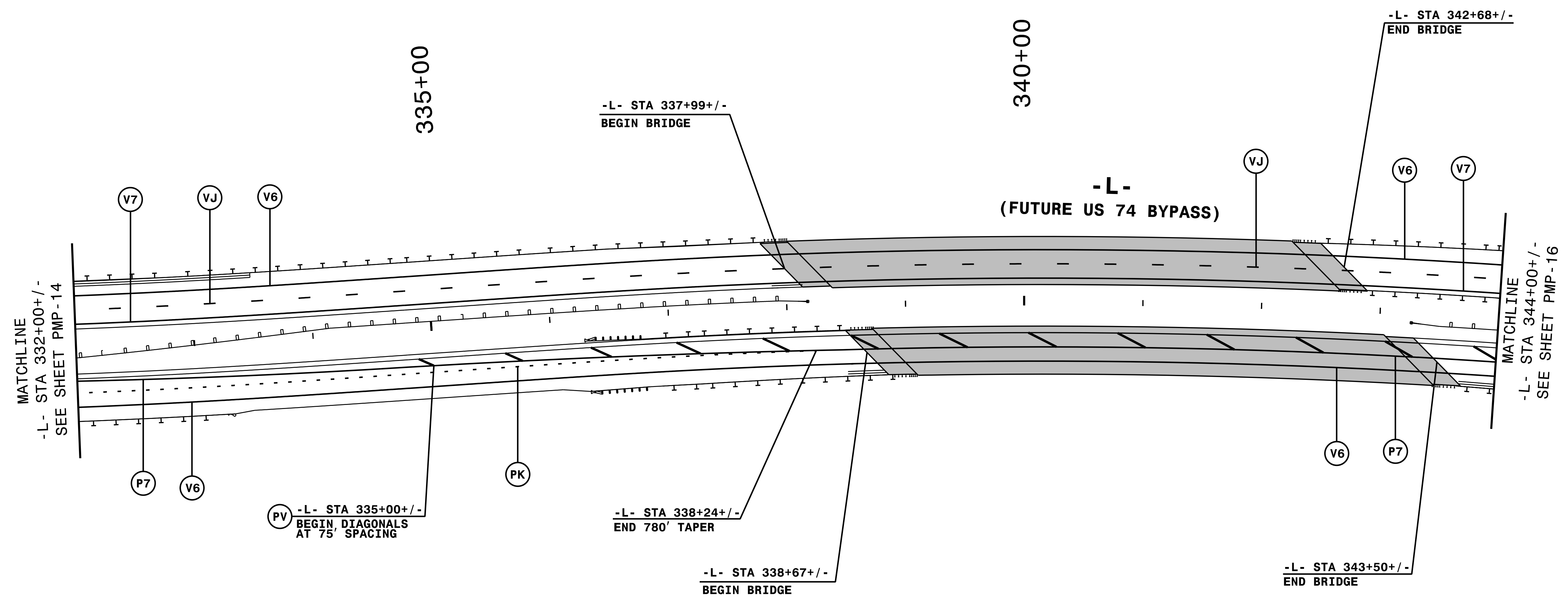
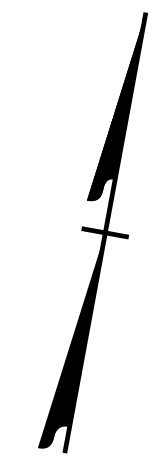

NOTE: ALL LANE WIDTHS ARE 12' UNLESS OTHERWISE SHOWN.

HNTB
 HNTB NORTH CAROLINA, P.C.
 343 E. SIX FORKS ROAD, SUITE 200
 RALEIGH, NORTH CAROLINA 27609
 NC LICENSE NO: C-1554
 (919) 546-6997

PAVEMENT MARKING DETAIL

10/17/2017
 \\hntb-gf-fic\pmp\2707F_PMP_15.dgn
 HNTB

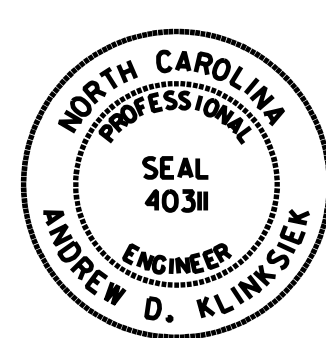
TIP NO. R-2707F	SHEET NO. PMP-16
APPROVED: <u>Andrew D. Klinck</u> <small>E3078FB4596E448</small>	
DATE: 10/17/2017	
	
DOCUMENT NOT CONSIDERED FINAL UNLESS ALL SIGNATURES COMPLETED	

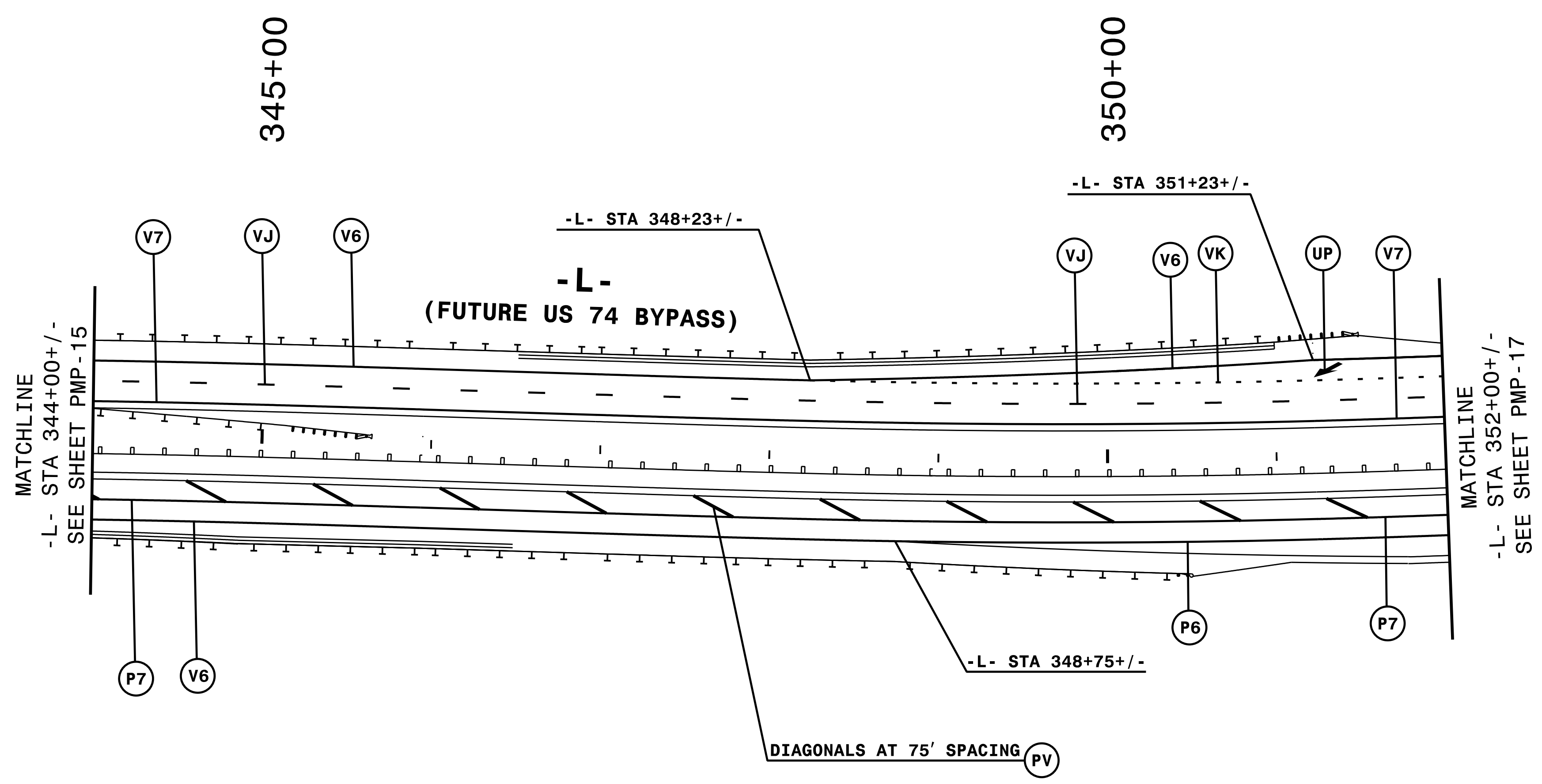
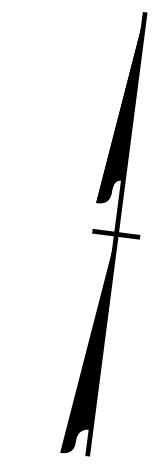

NOTE: ALL LANE WIDTHS ARE 12' UNLESS OTHERWISE SHOWN.

HNTB HNTB NORTH CAROLINA, P.C.
343 E. SIX FORKS ROAD, SUITE 200
RALEIGH, NORTH CAROLINA 27609
NC LICENSE NO: C-1554
(919) 546-6997

PAVEMENT MARKING DETAIL

10/17/2017
\\hntb-gf-fic\pmp\R2707F_PMP_16.dgn
HNTB

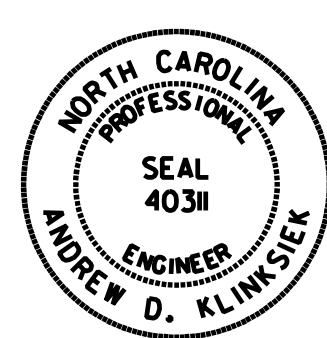
TIP NO. R-2707F	SHEET NO. PMP-18
APPROVED: <i>Andrew D. Klinck</i> E3078F8459E448	
DATE: 10/17/2017	
SEAL	
	
DOCUMENT NOT CONSIDERED FINAL UNLESS ALL SIGNATURES COMPLETED	

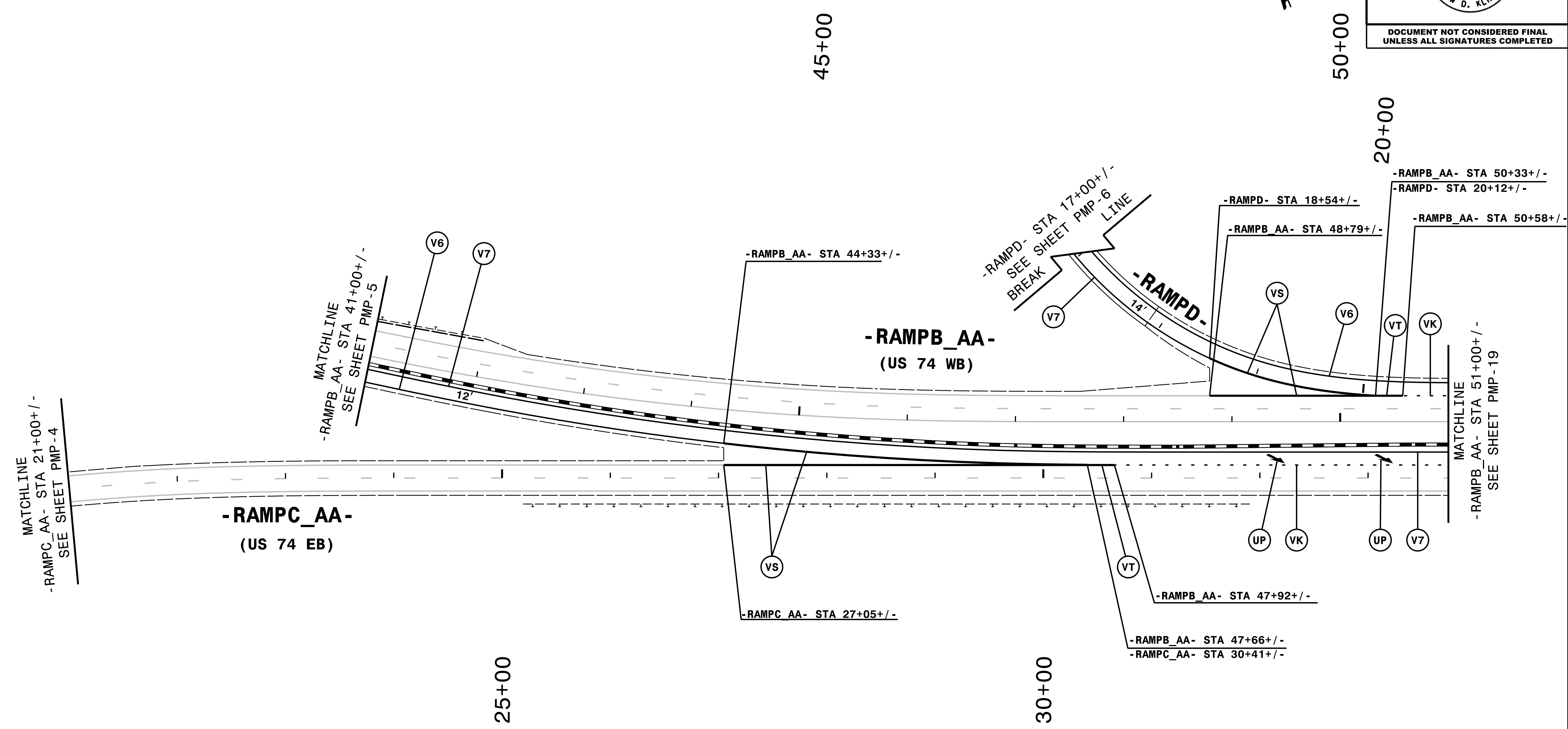

NOTE: ALL LANE WIDTHS ARE 12' UNLESS OTHERWISE SHOWN.

HNTB

HNTB NORTH CAROLINA, P.C.
343 E. SIX FORKS ROAD, SUITE 200
RALEIGH, NORTH CAROLINA 27609
NC LICENSE NO: C-1554
(919) 546-6997

PAVEMENT MARKING DETAIL

10/17/2017
I:\Projects\2017\10\17\101707F\101707F_PMP_18.dgn
HNTB

TIP NO. R-2707F	SHEET NO. PMP-19
APPROVED: <u>Andrew D. Klinck</u> <small>DocuSigned by: E3D78FB4596E44B</small>	
DATE: 10/17/2017	
SEAL 	
DOCUMENT NOT CONSIDERED FINAL UNLESS ALL SIGNATURES COMPLETED	

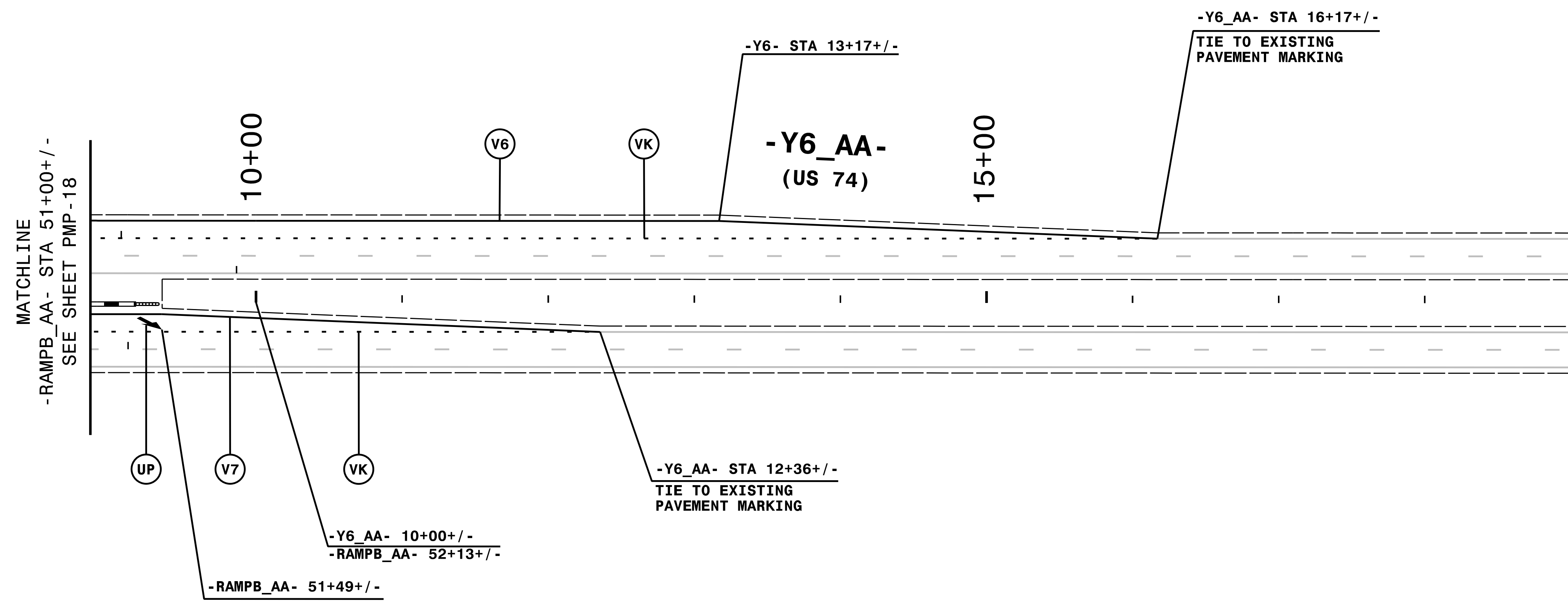
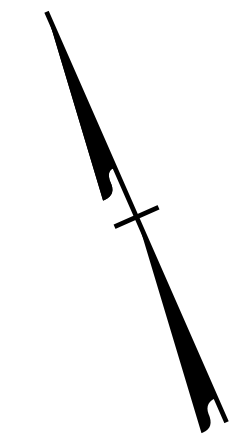

NOTE: ALL LANE WIDTHS ARE 12' UNLESS OTHERWISE SHOWN.

HNTB
HNTB NORTH CAROLINA, P.C.
343 E. SIX FORKS ROAD, SUITE 200
RALEIGH, NORTH CAROLINA 27609
NC LICENSE NO: C-1554
(919) 546-8997

PAVEMENT MARKING DETAIL

10/17/2017
\\T:\GFF\c\pmp\R2707F_PMP_19.dgn
HNTB

TIP NO. R-2707F	SHEET NO. PMP-21
APPROVED: <i>Andrew D. Klinck</i> <small>DocuSigned by: E3D78F84596E44B</small>	
DATE: 10/17/2017	
SEAL 	
DOCUMENT NOT CONSIDERED FINAL UNLESS ALL SIGNATURES COMPLETED	

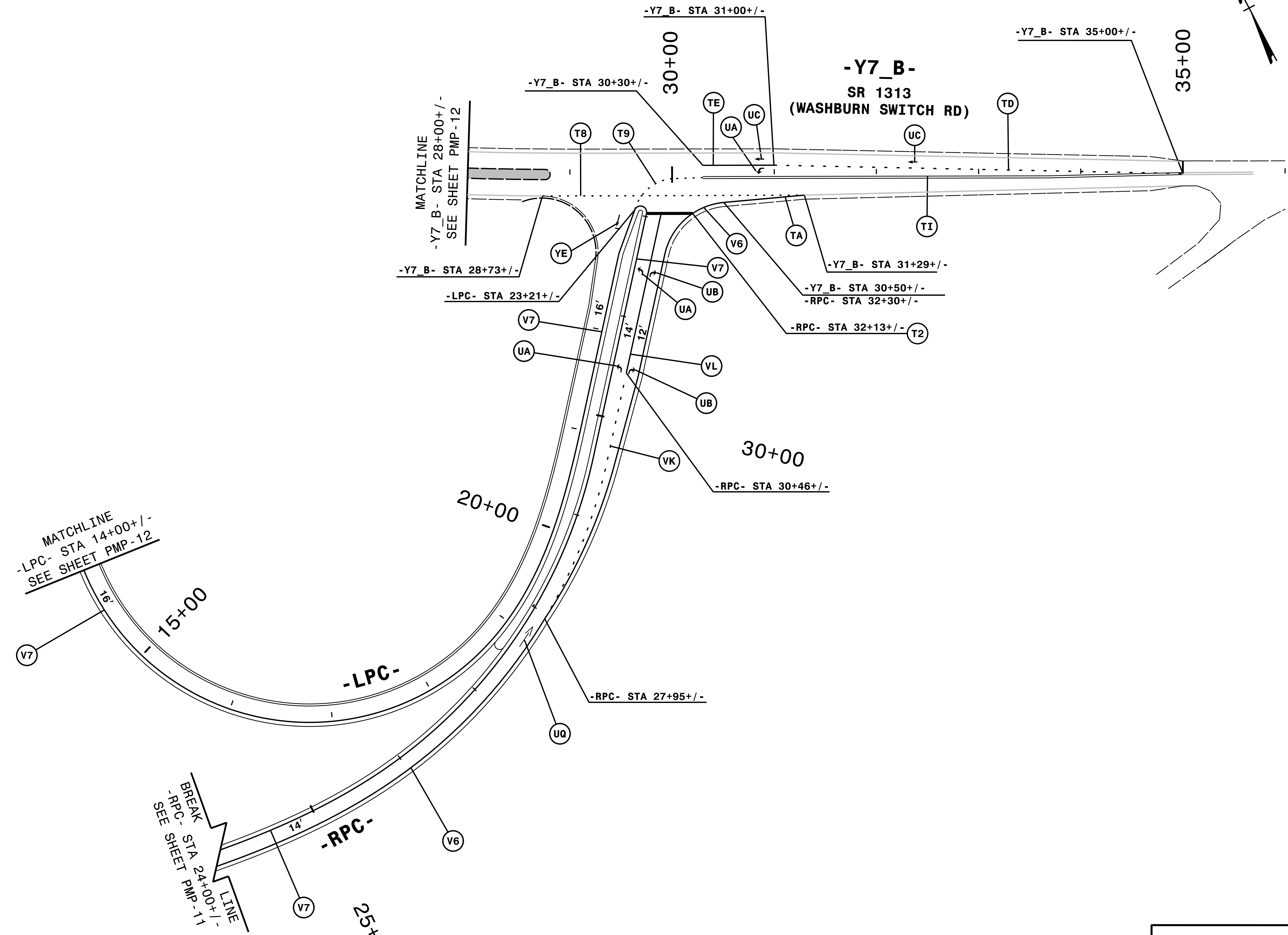

NOTE: ALL LANE WIDTHS ARE 12' UNLESS OTHERWISE SHOWN.

HNTB
HNTB NORTH CAROLINA, P.C.
 343 E. Six Forks Road, Suite 200
 Raleigh, North Carolina 27609
 NC License No: C-1554
 (919) 546-8997

PAVEMENT MARKING DETAIL

10/17/2017
\\T:\Office\PMP\R2707F_PMP_21.dgn
HNTB

