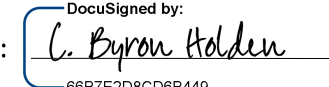
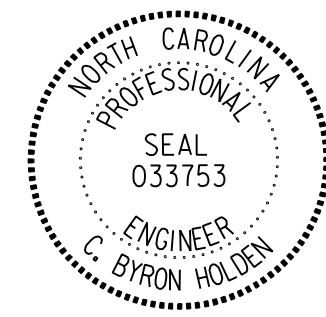

**This electronic collection of documents is provided  
for the convenience of the user  
and is Not a Certified Document –**

**The documents contained herein were originally issued  
and sealed by the individuals whose names and license  
numbers appear on each page, on the dates appearing  
with their signature on that page.**

**This file or an individual page  
shall not be considered a certified document.**

**STATE OF NORTH CAROLINA  
DEPARTMENT OF TRANSPORTATION**

PROJECT REFERENCE NO. U-5315 A&B	SHEET NO. PMP-1
APPROVED:  DATE: 11/11/2017	
	
DOCUMENT NOT CONSIDERED FINAL UNLESS ALL SIGNATURES COMPLETED	

**PAVEMENT MARKING PLAN**  
**LOCATION: MORRISVILLE PARKWAY EXTENSION AND NC 540 INTERCHANGE**  
**FROM WEST OF HIGHCROFT DRIVE TO EAST OF MILLS PARK DRIVE IN CARY**  
**WAKE COUNTY**

**T.I.P.: U-5315 A&B**

**ROADWAY STANDARD DRAWING**

THE FOLLOWING ROADWAY STANDARDS AS APPEAR IN "ROADWAY STANDARD DRAWINGS" - PROJECT SERVICES UNIT - N.C. DEPARTMENT OF TRANSPORTATION - RALEIGH, N.C., DATED JANUARY 2012 ARE APPLICABLE TO THIS PROJECT AND BY REFERENCE HEREBY ARE CONSIDERED A PART OF THESE PLANS:

STD. NO.	TITLE
1205.01	PAVEMENT MARKINGS - LINE TYPES AND OFFSETS
1205.02	PAVEMENT MARKINGS - TWO-LANE AND MULTILANE ROADWAYS
1205.03	PAVEMENT MARKINGS - EXIT AND ENTRANCE RAMP
1205.04	PAVEMENT MARKINGS - INTERSECTIONS
1205.05	PAVEMENT MARKINGS - TURN LANES
1205.06	PAVEMENT MARKINGS - LANE DROPS
1205.07	PAVEMENT MARKINGS - PEDESTRIAN CROSSWALKS
1205.08	PAVEMENT MARKINGS - SYMBOLS AND WORD MESSAGES
1205.09	PAVEMENT MARKINGS - PAINTED ISLANDS
1205.12	PAVEMENT MARKINGS - BRIDGES
1205.13	PAVEMENT MARKINGS - LANE REDUCTIONS
1250.01	RAISED PAVEMENT MARKERS - INSTALLATION SPACING
1251.01	RAISED PAVEMENT MARKERS - PERMANENT AND TEMPORARY
1253.01	RAISED PAVEMENT MARKERS - SNOWPLOWABLE
1261.01	GUARDRAIL AND BARRIER DELINEATORS - INSTALLATION SPACING
1261.02	GUARDRAIL AND BARRIER DELINEATORS - TYPES AND MOUNTING
1262.01	GUARDRAIL END DELINEATION
1264.01	OBJECT MARKERS - TYPES
1264.02	OBJECT MARKERS - INSTALLATION

**INDEX**

SHEET NO.	DESCRIPTION
PMP-1	PAVEMENT MARKING PLAN INDEX OF SHEETS, ROADWAY STANDARD DRAWINGS, GENERAL NOTES AND FINAL PAVEMENT MARKING SCHEDULE
PMP-1A	1205D08, SHEET 3 OF 8 PAVEMENT MARKINGS - SYMBOLS AND WORD MESSAGES
PMP-2-8	PAVEMENT MARKING DETAIL

**GENERAL NOTES**

- THE FOLLOWING GENERAL NOTES APPLY AT ALL TIMES FOR THE DURATION OF THE CONSTRUCTION PROJECT, EXCEPT WHEN OTHERWISE NOTED IN THE PLAN, OR DIRECTED BY THE ENGINEER.
- A) INSTALL PAVEMENT MARKINGS AND PAVEMENT MARKERS ON THE FINAL SURFACE AS FOLLOWS:

ROAD NAME	MARKING	MARKER
NC 540	POLYUREA, (HRE)	SNOWPLOWABLE RAISED REFLECTIVE
LOOPS AND RAMP	THERMOPLASTIC	SNOWPLOWABLE RAISED REFLECTIVE
-L- MORRISVILLE PARKWAY	THERMOPLASTIC	RAISED REFLECTIVE
-L- MORRISVILLE PARKWAY BRIDGE	POLYUREA, (HRE)	RAISED REFLECTIVE
-Y1- TWYLA ROAD	THERMOPLASTIC	RAISED REFLECTIVE
  - B) ON ASPHALT SURFACES, INSTALL HEATED-IN-PLACE THERMOPLASTIC OR EXTRUDED THERMOPLASTIC MARKINGS FOR STOP BARS, SYMBOLS, CROSSWALKS AND DIAGONAL.
  - C) TIE PROPOSED PAVEMENT MARKING LINES TO EXISTING PAVEMENT MARKING LINES.
  - D) REMOVE/REPLACE ANY CONFLICTING/DAMAGED PAVEMENT MARKINGS AND MARKERS.
  - E) PASSING ZONES WILL BE DETERMINED IN THE FIELD AND MUST BE APPROVED BY THE ENGINEER.
  - F) STOP BAR LOCATION AT NON-SIGNALIZED INTERSECTIONS MAY BE ADJUSTED AS DIRECTED BY THE ENGINEER.
  - G) REMOVE ALL RESIDUE AND SURFACE LAITANCE BY ACCEPTABLE METHODS ON CONCRETE BRIDGE DECKS PRIOR TO PLACING COLD APPLIED TYPE II PAVEMENT MARKING MATERIAL.
  - H) UNLESS OTHERWISE SPECIFIED, HEATED-IN-PLACE THERMOPLASTIC MAY BE USED IN LIEU OF EXTRUDED THERMOPLASTIC FOR STOP BARS, SYMBOLS, CHARACTERS AND DIAGONALS. IF HEATED-IN-PLACE IS USED, IT SHALL BE PAID FOR USING THE EXTRUDED THERMOPLASTIC PAY ITEM.
  - I) SEE ROADWAY PLANS FOR ALTERNATE CURB RAMP DESIGNS WHEN INDICATED ON PAVEMENT MARKING DETAIL SHEETS.

**FINAL PAVEMENT MARKING SCHEDULE**

T2	WHITE STOP BAR (24", 120 MIL)	
T3	WHITE CROSSWALK LINE (24", 120 MIL)	
T6	WHITE EDGELINE (6", 90 MIL)	
T7	YELLOW EDGELINE (6", 90 MIL)	
T8	2 FT. - 6 FT./SP WHITE MINISKIP (4", 120 MIL)	
T17	3 FT. - 3 FT./SP WHITE MINISKIP (8", 120 MIL)	
TA	WHITE EDGELINE (4", 90 MIL)	
TB	YELLOW EDGELINE (4", 90 MIL)	
TD	3 FT. - 9 FT./SP WHITE MINISKIP (4", 120 MIL)	
TE	WHITE SOLID LANE LINE (4", 120 MIL)	
TI	YELLOW DOUBLE CENTER (4", 120 MIL)	
TK	3 FT. - 9 FT./SP WHITE MINISKIP (6", 120 MIL)	
TL	WHITE SOLID LANE LINE (6", 120 MIL)	
TN	WHITE GORELINE (8", 90 MIL)	
TP	YELLOW DIAGONAL (8", 90 MIL)	
TR	WHITE SOLID LANE LINE (8", 120 MIL)	
TS	WHITE GORELINE (12", 90MIL)	
TT	WHITE SOLID LANE LINE (12", 120 MIL)	
UA	LEFT TURN ARROW (90 MIL)	
UB	RIGHT TURN ARROW (90 MIL)	
UC	STRAIGHT ARROW (90 MIL)	
UD	COMBO. LEFT/STRAIGHT ARROW (90 MIL)	
UN	24" YIELD LINE TRIANGLE (90 MIL)	
UP	MERGE ARROW (90 MIL)	
UU	FISH-HOOK STRAIGHT ARROW (90 MIL)	
UZ	FISH-HOOK W/CIRCLE STRAIGHT ARROW (90 MIL)	
YA	FISH-HOOK W/CIRCLE LEFT ARROW (90 MIL)	
POLYUREA (HRE)		
V5	10 FT. BLACK SKIP (6")	
V6	WHITE EDGELINE (6")	
V7	YELLOW EDGELINE (6")	
VA	WHITE EDGELINE (4")	
VI	YELLOW DOUBLE CENTER (4")	
VJ	10 FT. WHITE SKIP (6")	
VK	3 FT. - 9 FT./SP WHITE MINISKIP (6")	
VS	WHITE GORELINE (12")	
VT	WHITE SOLID LANE LINE (12")	
PAVEMENT MARKERS		
MA	PERMANENT RAISED MARKER	YELLOW & YELLOW
MB	PERMANENT RAISED MARKER	CRYSTAL & RED
MC	PERMANENT RAISED MARKER	YELLOW & RED
MF	SNOWPLOWABLE MARKER	CRYSTAL & RED

**PLAN REVIEWED BY: N.C.D.O.T. SIGNING AND DELINEATION UNIT**

A. ALQUDWAH, PE SIGNING & DELINEATION REGIONAL ENGINEER  
M. EATON, PE SIGNING & DELINEATION DESIGN ENGINEER

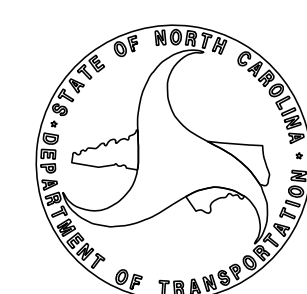

**PLAN PREPARED BY: RK&K**

C. B. HOLDEN, PE PROJECT MANAGER  
K. W. BISBY, PE SENIOR PROJECT ENGINEER  
M. A. COLE SENIOR DESIGNER



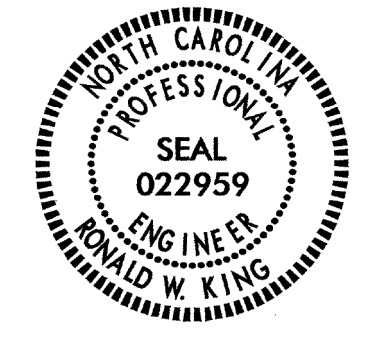

TIP NO. U-5315 A&B	SHEET NO. PMP-1A
APPROVED: <i>RWF</i>	
DATE: 3/8/12	
SEAL	
	

STATE OF NORTH CAROLINA  
DEPT. OF TRANSPORTATION  
DIVISION OF HIGHWAYS  
RALEIGH, N.C.

ENGLISH DETAIL DRAWING FOR  
PAVEMENT MARKINGS  
SYMBOLS AND WORD MESSAGES

SHEET 3 OF 8  
**1205D08**

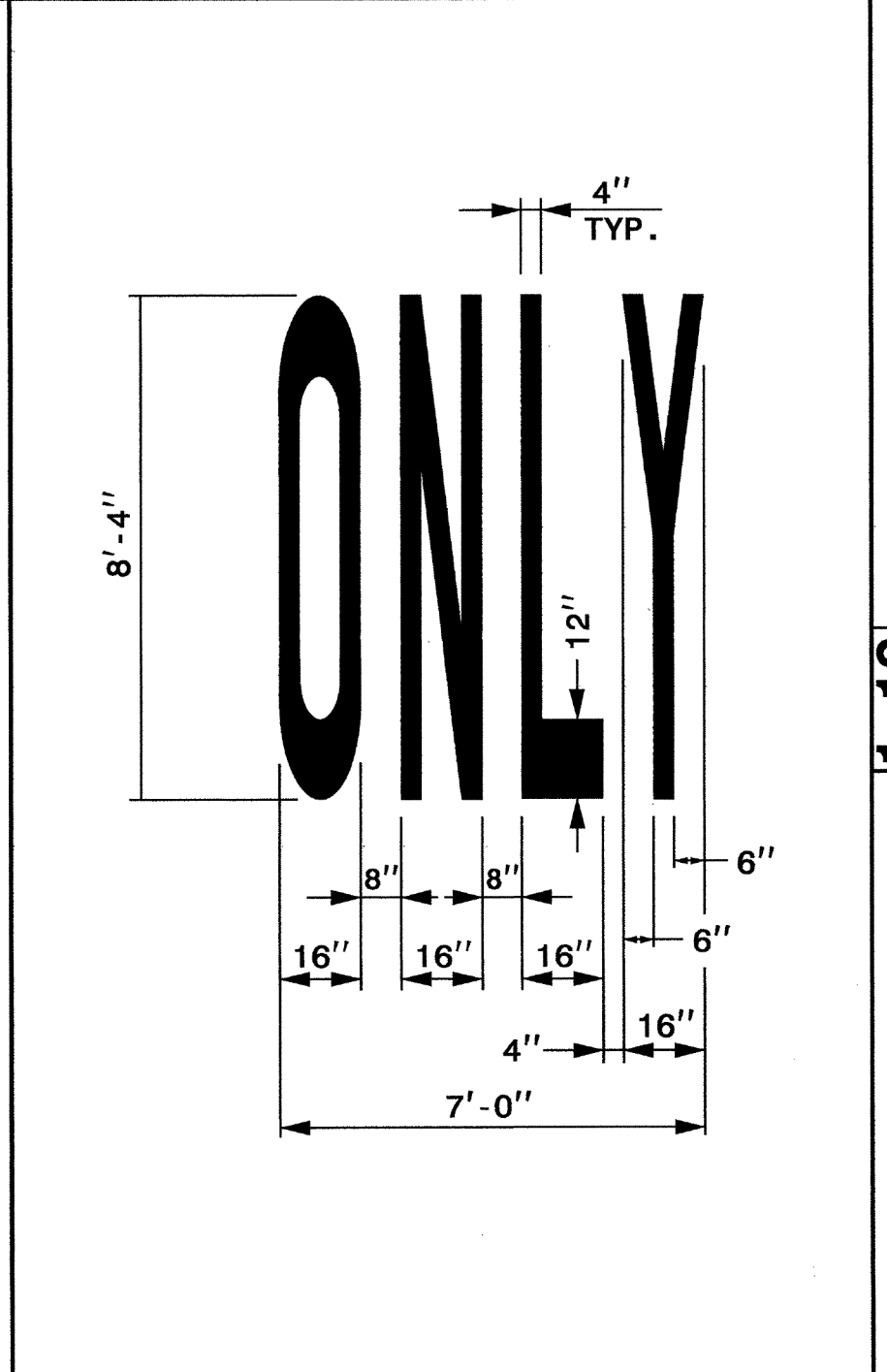
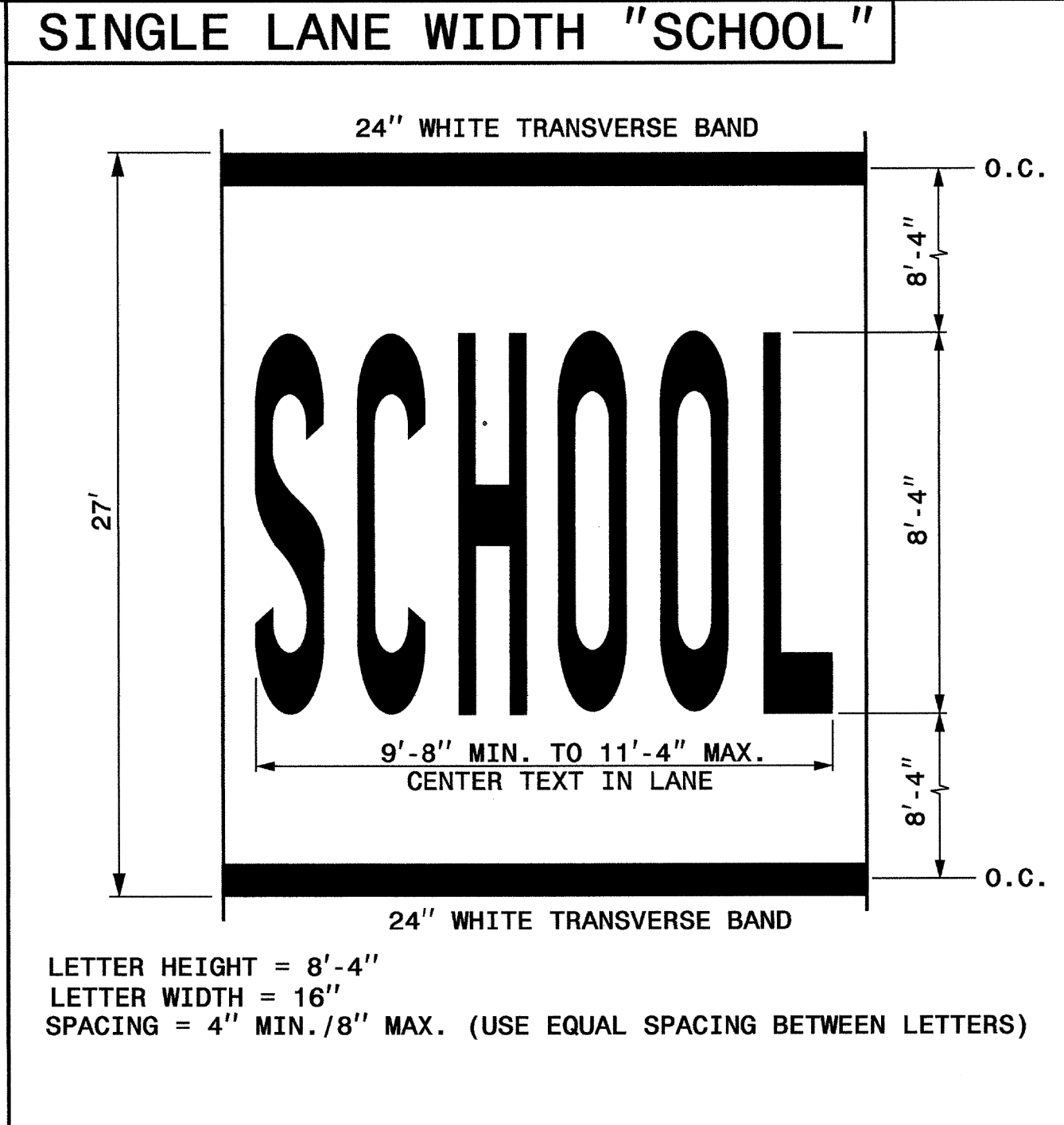
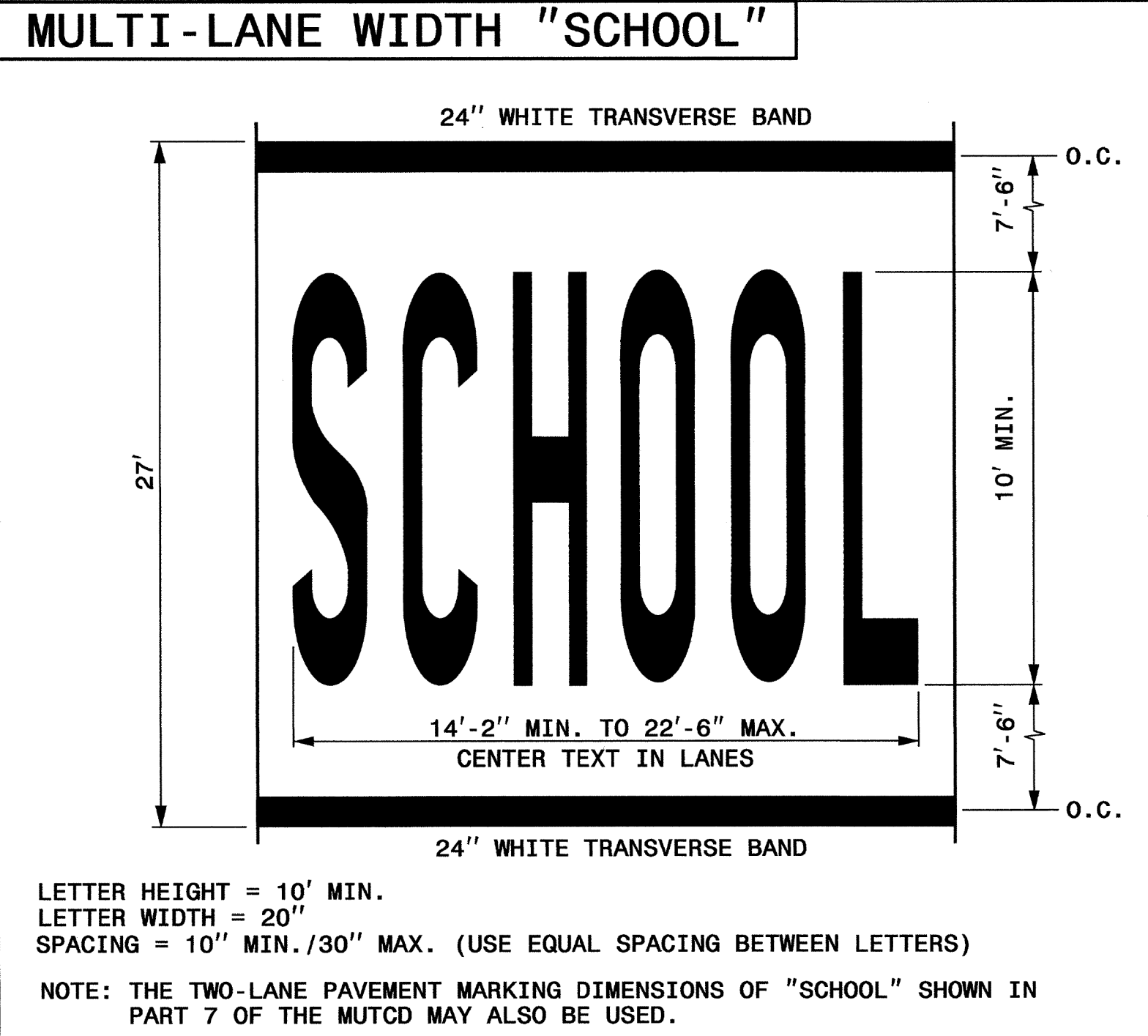

STATE OF NORTH CAROLINA  
DEPT. OF TRANSPORTATION  
DIVISION OF HIGHWAYS  
RALEIGH, N.C.

ENGLISH DETAIL DRAWING FOR  
PAVEMENT MARKINGS  
SYMBOLS AND WORD MESSAGES

SHEET 3 OF 8  
**1205D08**

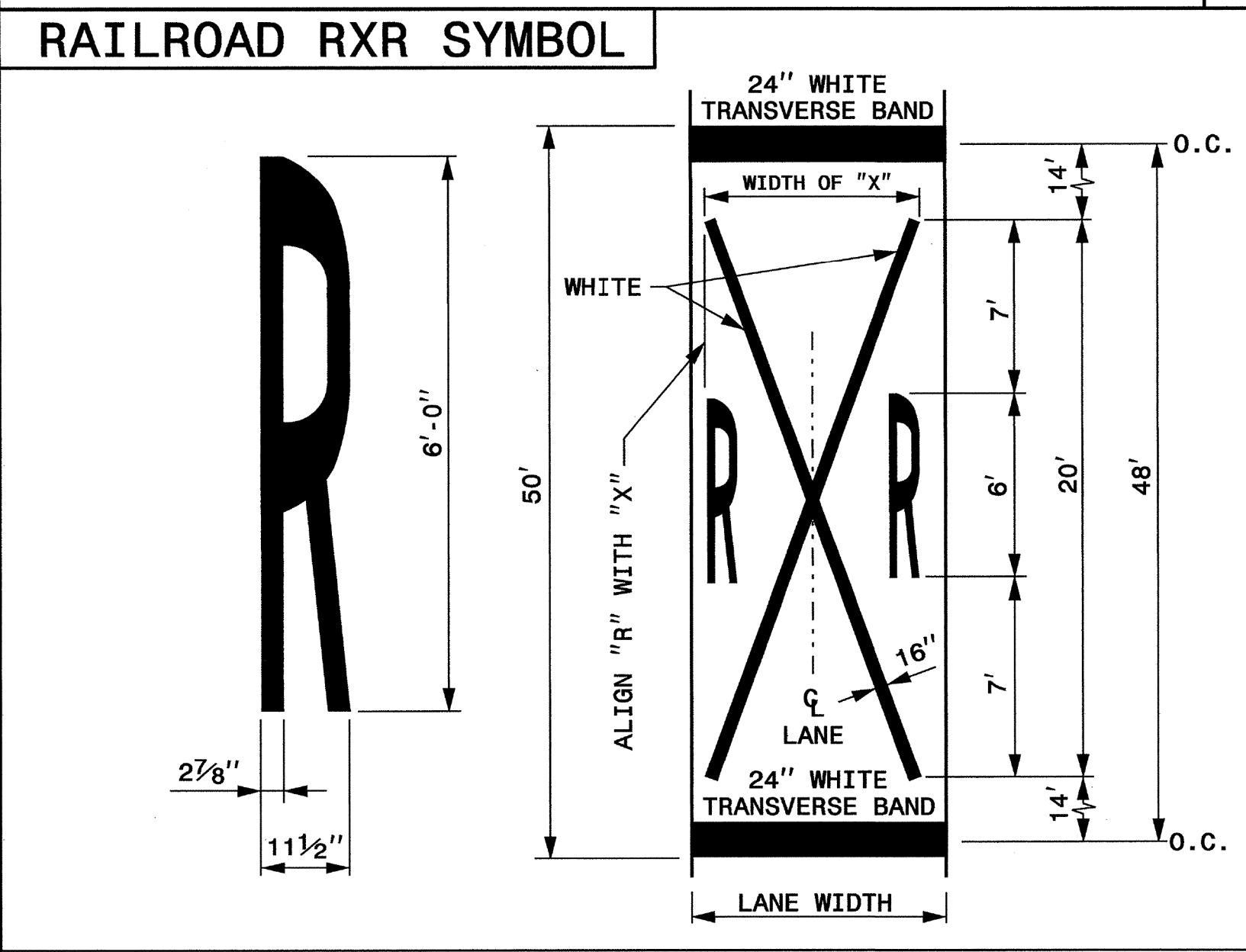

LANE WIDTH (FEET)	WIDTH OF "X" (FEET)
8' ≤ W ≤ 9'	7'
9' < W ≤ 12'	8'
W > 12'	10'

- GENERAL NOTES:
- 1- THE SCHOOL PAVEMENT MARKING CONSISTS OF SIX (6) CHARACTERS. THE TWO (2) 24" TRANSVERSE BANDS WILL BE PAID FOR UNDER A SEPARATE PAY ITEM. REFER TO ROADWAY STANDARD DRAWING 1205.10 FOR ADDITIONAL PAVEMENT MARKING GUIDANCE.
  - 2- PAVEMENT MARKING IN ADVANCE OF A HIGHWAY-RAIL CROSSING SHALL CONSIST OF TWO (2) CHARACTERS AND TWO (2) 16" LINES (FORMING AN X) WHICH ARE PAID FOR UNDER TWO SEPARATE PAY ITEMS. THE TWO (2) 24" TRANSVERSE BANDS WILL BE PAID FOR UNDER A SEPARATE PAY ITEM. REFER TO ROADWAY STANDARD DRAWING 1205.11 FOR ADDITIONAL PAVEMENT MARKING GUIDANCE.

**REVISED PAVEMENT MARKING  
ROADWAY STANDARD DRAWING**

08-MAR-2012 12:18  
S:\S&D\Standard\Drawings\Standard Drawings\NMP\2012 Standard Drawings\Standard Drawings\2050803\_Rev12\_9-14-11\_Secled.dgn  
AT 1E244745

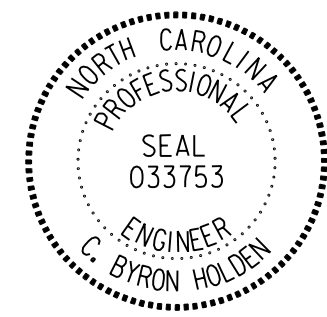
TIP NO.	SHEET NO.
U-5315 A&B	PMP-2
APPROVED: 	
DATE: 11/11/2017	
	
<p><b>DOCUMENT NOT CONSIDERED FINAL UNLESS ALL SIGNATURES COMPLETED</b></p>	

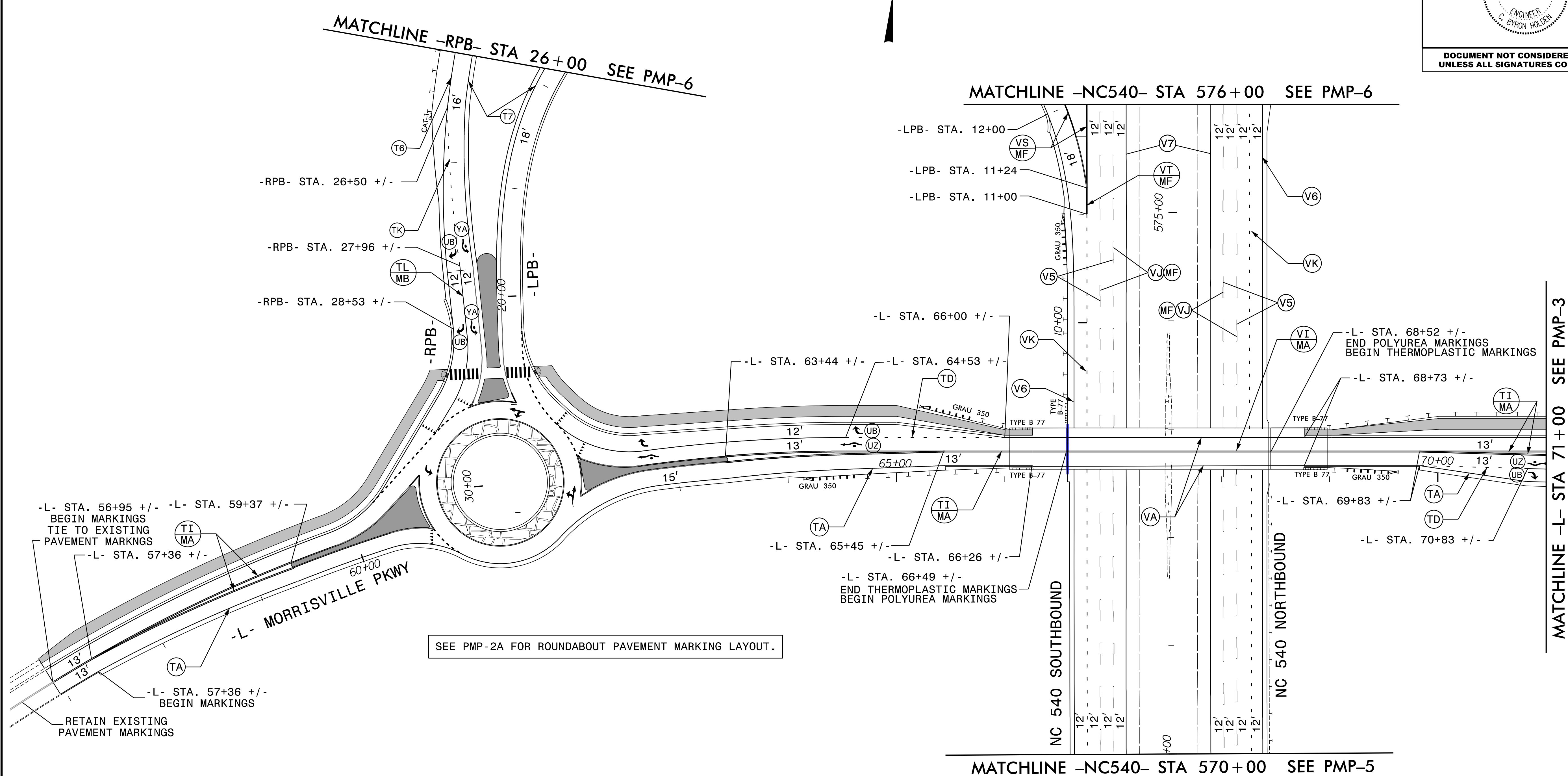

PLANS PREPARED BY:

**RK&K**

RUMMEL, KLEPPER & KAHL, LLP  
 900 RIDGEFIELD DRIVE, SUITE 350  
 RALEIGH, NORTH CAROLINA 27609  
 NC LICENSE NO. F-0112  
 1-888-521-4455 OR 919-878-9560

**PAVEMENT MARKING DETAIL**

11/9/2017 11:37:15 am U:\5315\pmp-psf02.dgn

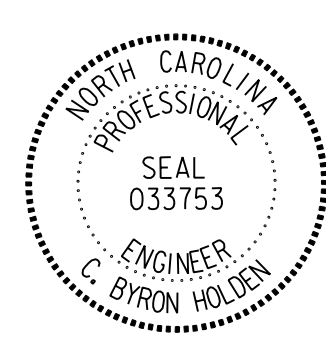

TIP NO. U-5315 A&B	SHEET NO. PMP-2A
APPROVED: <i>C. Byron Holden</i> 11/11/2017	
DATE: 11/11/2017	
SEAL 	
DOCUMENT NOT CONSIDERED FINAL UNLESS ALL SIGNATURES COMPLETED	

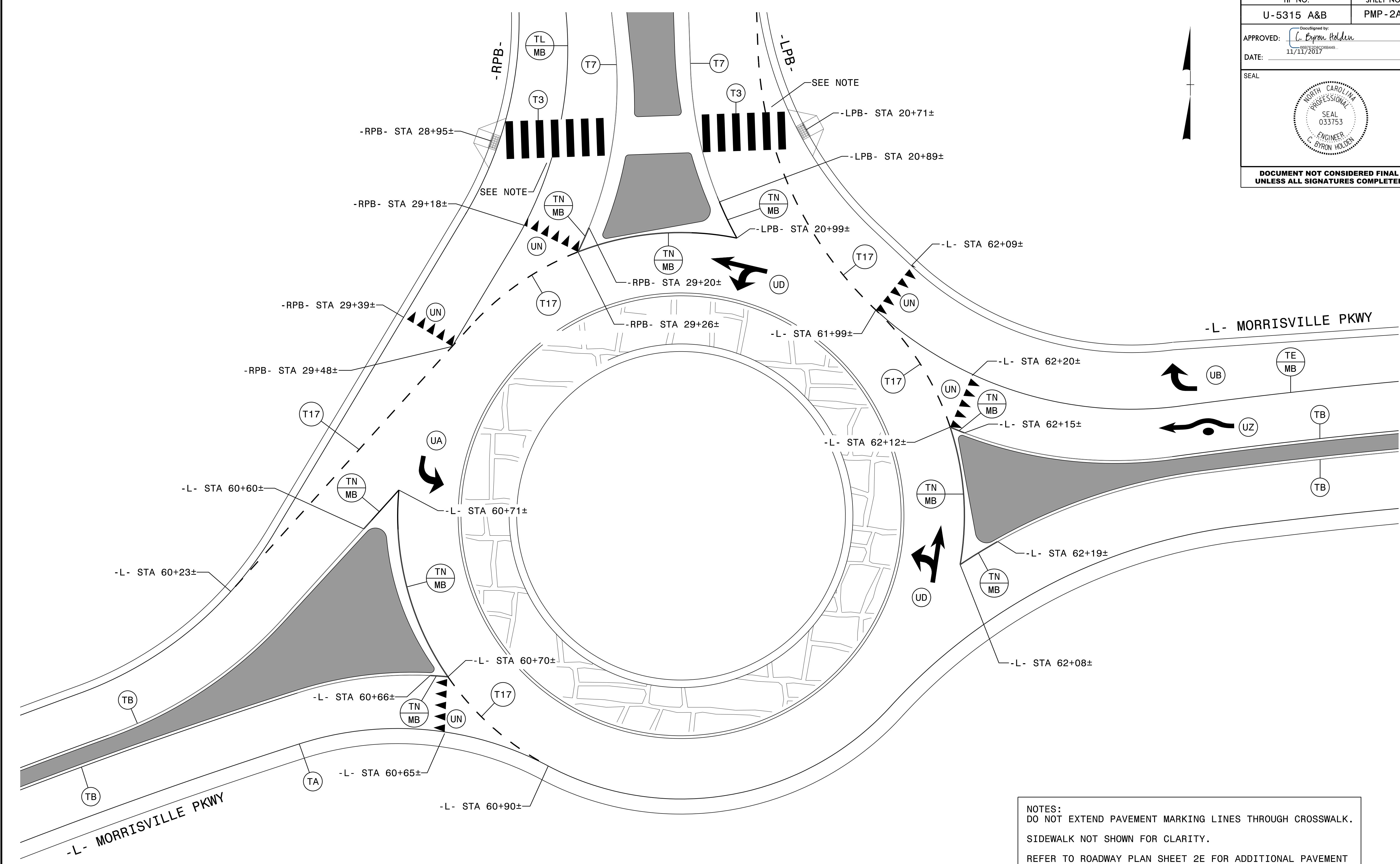

NOTES:  
 DO NOT EXTEND PAVEMENT MARKING LINES THROUGH CROSSWALK.  
 SIDEWALK NOT SHOWN FOR CLARITY.  
 REFER TO ROADWAY PLAN SHEET 2E FOR ADDITIONAL PAVEMENT MARKING LAYOUT GUIDANCE AND LANE WIDTHS.

PLANS PREPARED BY:  
  
 RUMMEL, KLEPPER & KAHL, LLP  
 900 RIDGEFIELD DRIVE, SUITE 350  
 RALEIGH, NORTH CAROLINA 27609  
 NC LICENSE NO. F-0112  
 1-888-521-4455 OR 919-878-9560

**PAVEMENT MARKING DETAIL**

11/9/2017  
U-5315-imp-psf02A.dgn  
CS&S

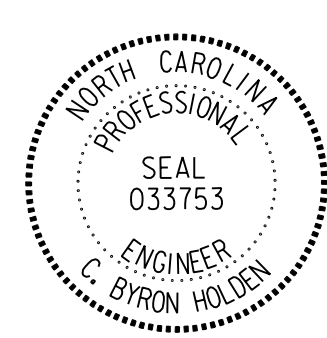
TIP NO. U-5315 A&B	SHEET NO. PMP-3
APPROVED: <i>C. Byron Holden</i> 11/11/2017	
DATE: 11/11/2017	
SEAL 	
DOCUMENT NOT CONSIDERED FINAL UNLESS ALL SIGNATURES COMPLETED	

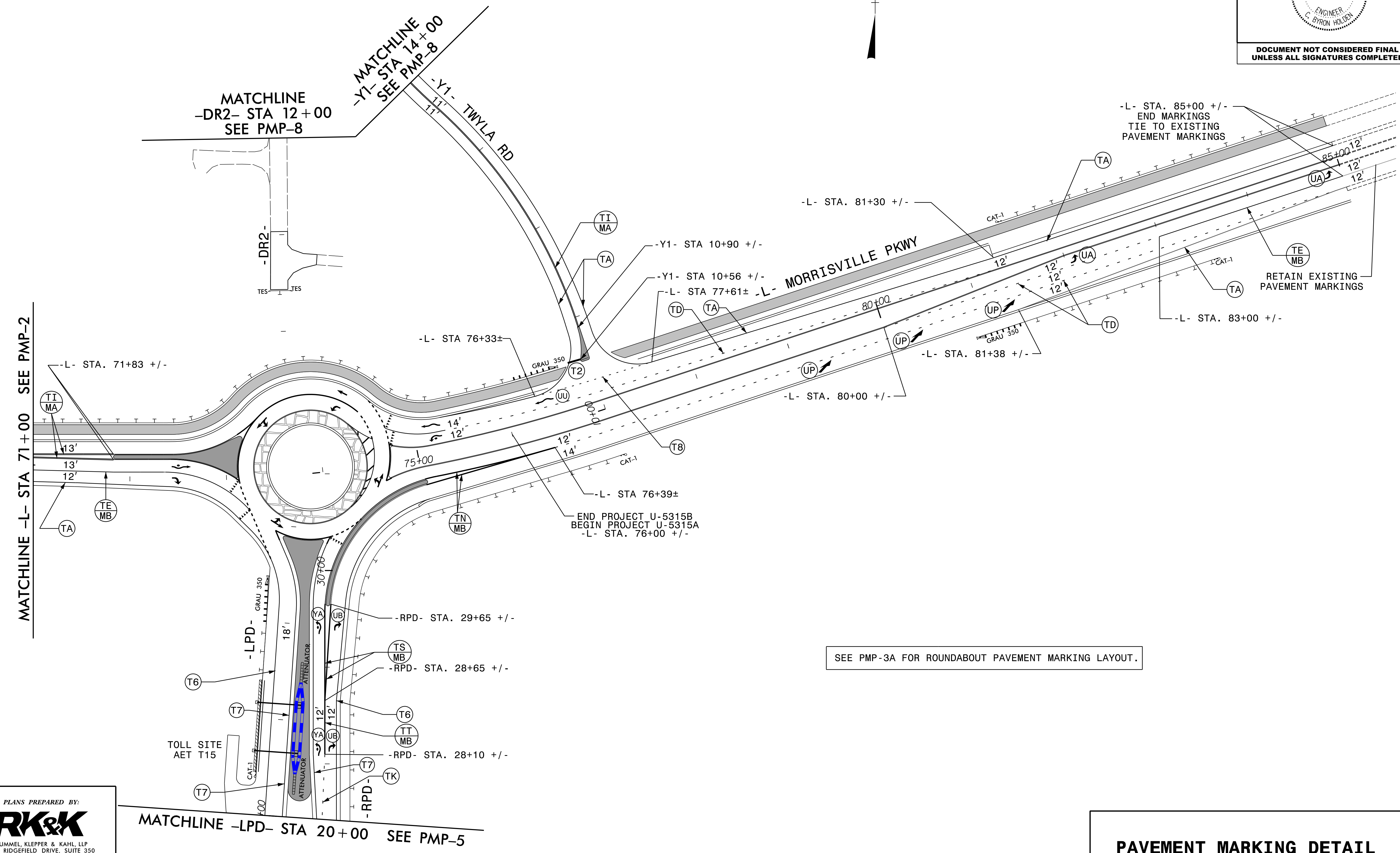

PLANS PREPARED BY:

**RK&K**

RUMMEL, KLEPPER & KAHL, LLP  
900 RIDGEFIELD DRIVE, SUITE 350  
RALEIGH, NORTH CAROLINA 27609  
NC LICENSE NO. F-0112  
1-888-521-4455 OR 919-878-9560

**PAVEMENT MARKING DETAIL**

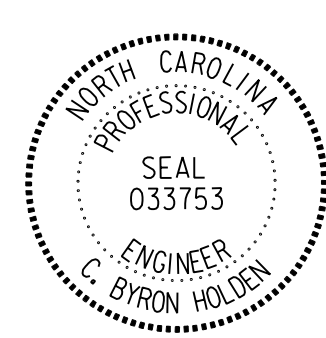

TIP NO. U-5315 A&B	SHEET NO. PMP-3A
APPROVED: <i>C. Byron Holden</i> 11/11/2017	
DATE: 11/11/2017	
SEAL 	
DOCUMENT NOT CONSIDERED FINAL UNLESS ALL SIGNATURES COMPLETED	

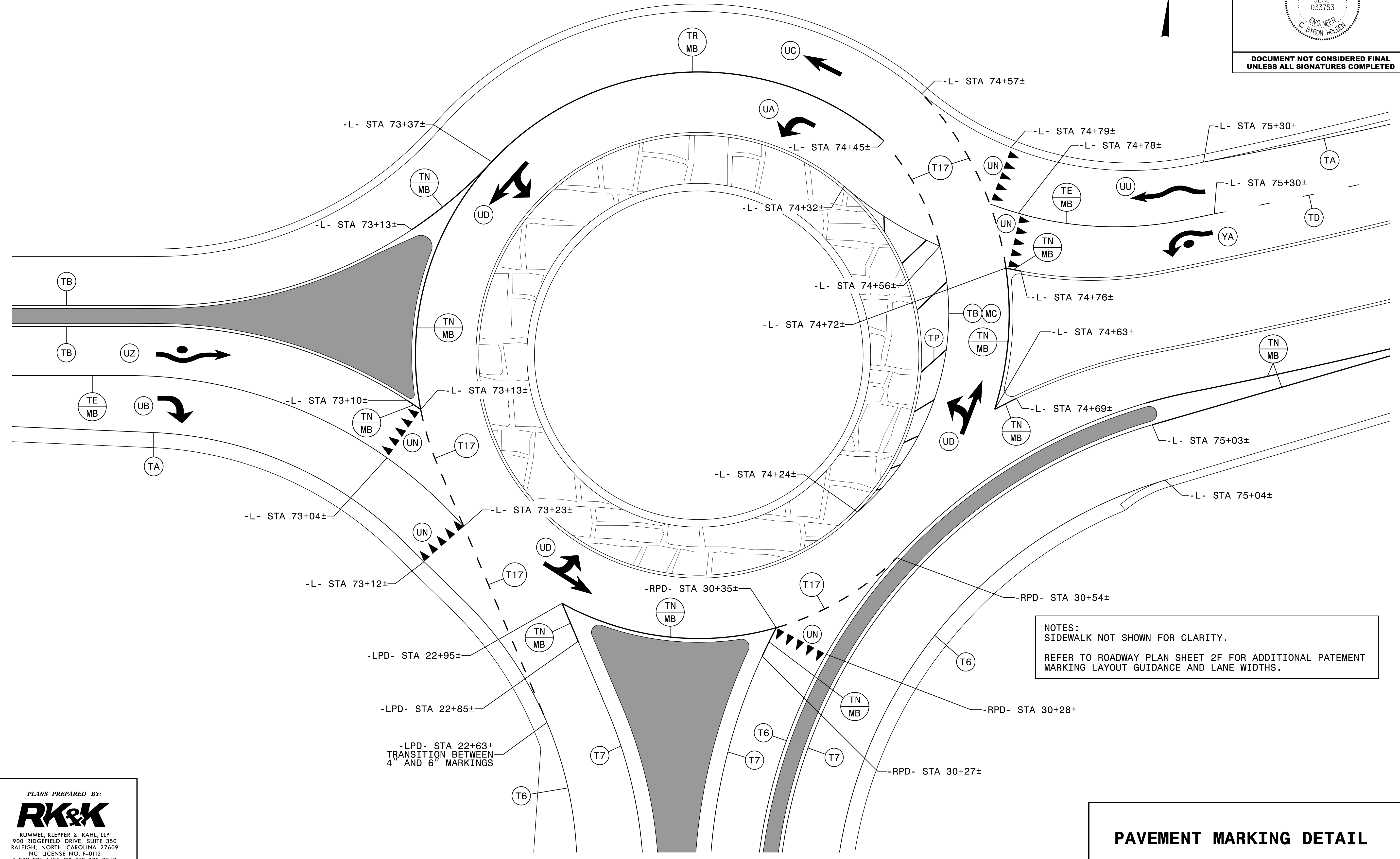
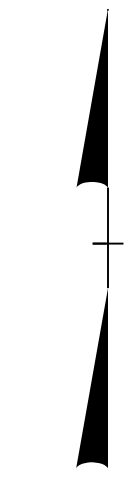

NOTES:  
 SIDEWALK NOT SHOWN FOR CLARITY.  
 REFER TO ROADWAY PLAN SHEET 2F FOR ADDITIONAL PAVEMENT  
 MARKING LAYOUT GUIDANCE AND LANE WIDTHS.

**PAVEMENT MARKING DETAIL**

PLANS PREPARED BY:  
  
 RUMMEL, KLEPPER & KAHL, LLP  
 900 RIDGEFIELD DRIVE, SUITE 350  
 RALEIGH, NORTH CAROLINA 27609  
 NC LICENSE NO. F-0112  
 1-888-521-4455 OR 919-878-9560

11/9/2017  
 U5315\_ump\_psh03A.dgn  
 c3eartls

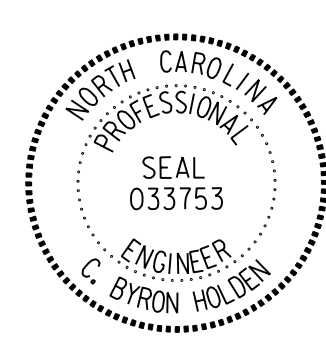
TIP NO. U-5315 A&B	SHEET NO. PMP-4
APPROVED: <i>C. Byron Holden</i> DATE: 11/11/2017	
SEAL 	
DOCUMENT NOT CONSIDERED FINAL UNLESS ALL SIGNATURES COMPLETED	

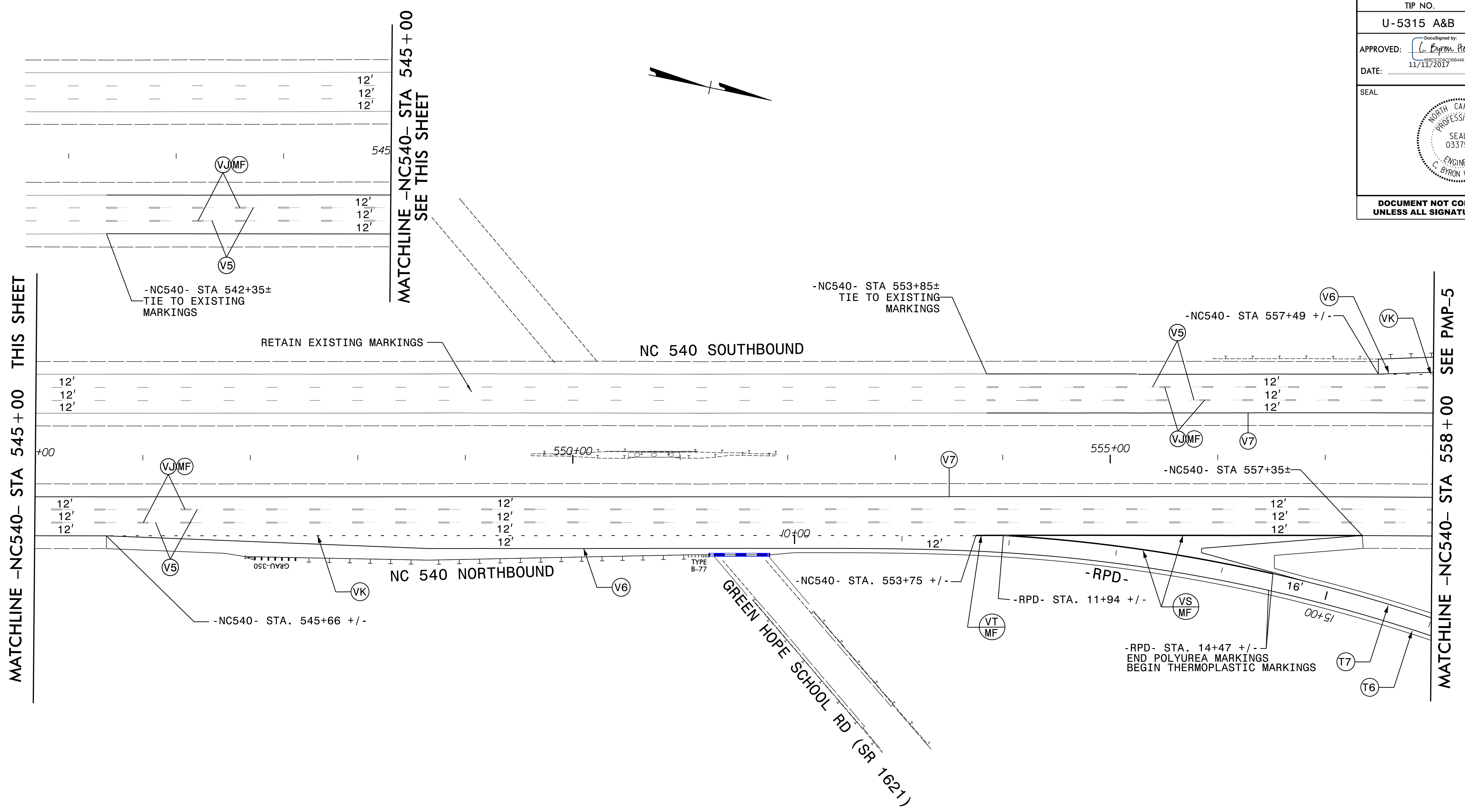

11/9/2017 11:37:15 am psh04.dgn

PLANS PREPARED BY:  
  
 RUMMEL, KLEPPER & KAHL, LLP  
 900 RIDGEFIELD DRIVE, SUITE 350  
 RALEIGH, NORTH CAROLINA 27609  
 NC LICENSE NO. F-0112  
 1-888-521-4455 OR 919-878-9560

PAVEMENT MARKING DETAIL

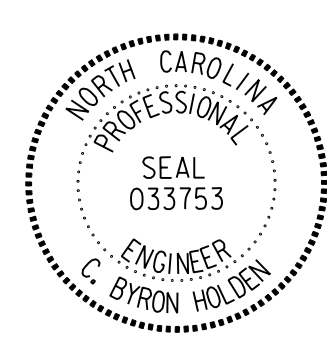

TIP NO. U-5315 A&B	SHEET NO. PMP-5
APPROVED: <i>C. Byron Holden</i> 11/11/2017	
DATE: 11/11/2017	
SEAL 	
DOCUMENT NOT CONSIDERED FINAL UNLESS ALL SIGNATURES COMPLETED	

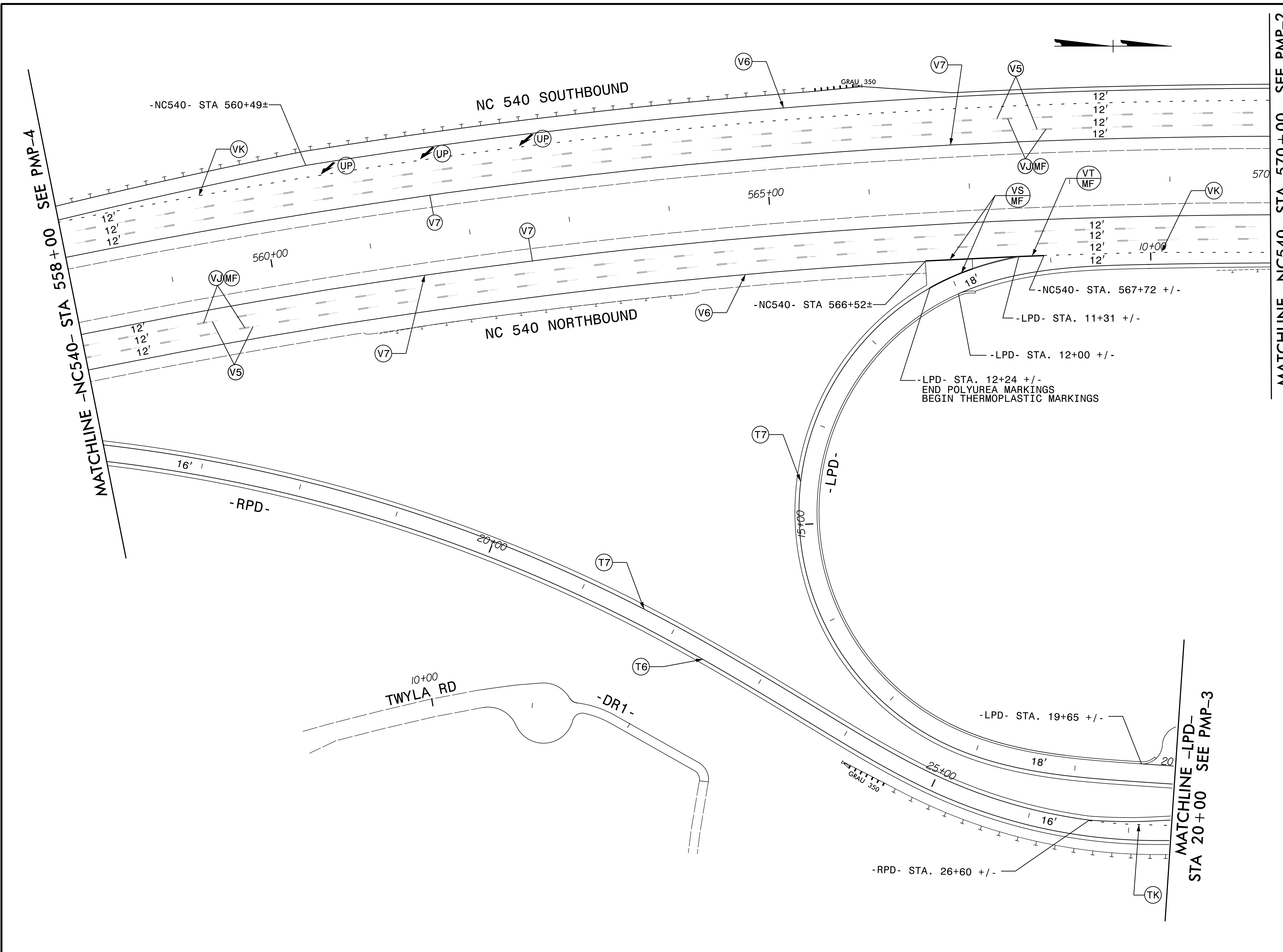

PLANS PREPARED BY:  
  
 RUMMEL, KLEPPER & KAHL, LLP  
 900 RIDGEFIELD DRIVE, SUITE 350  
 RALEIGH, NORTH CAROLINA 27609  
 NC LICENSE NO. F-0112  
 1-888-521-4455 OR 919-878-9560

**PAVEMENT MARKING DETAIL**

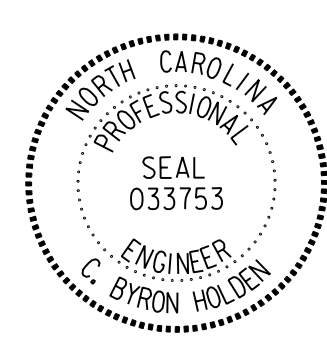
TIP NO. U-5315 A&B	SHEET NO. PMP-6
APPROVED: <i>C. Byron Holden</i> 11/11/2017	
DATE: 11/11/2017	
SEAL 	
DOCUMENT NOT CONSIDERED FINAL UNLESS ALL SIGNATURES COMPLETED	

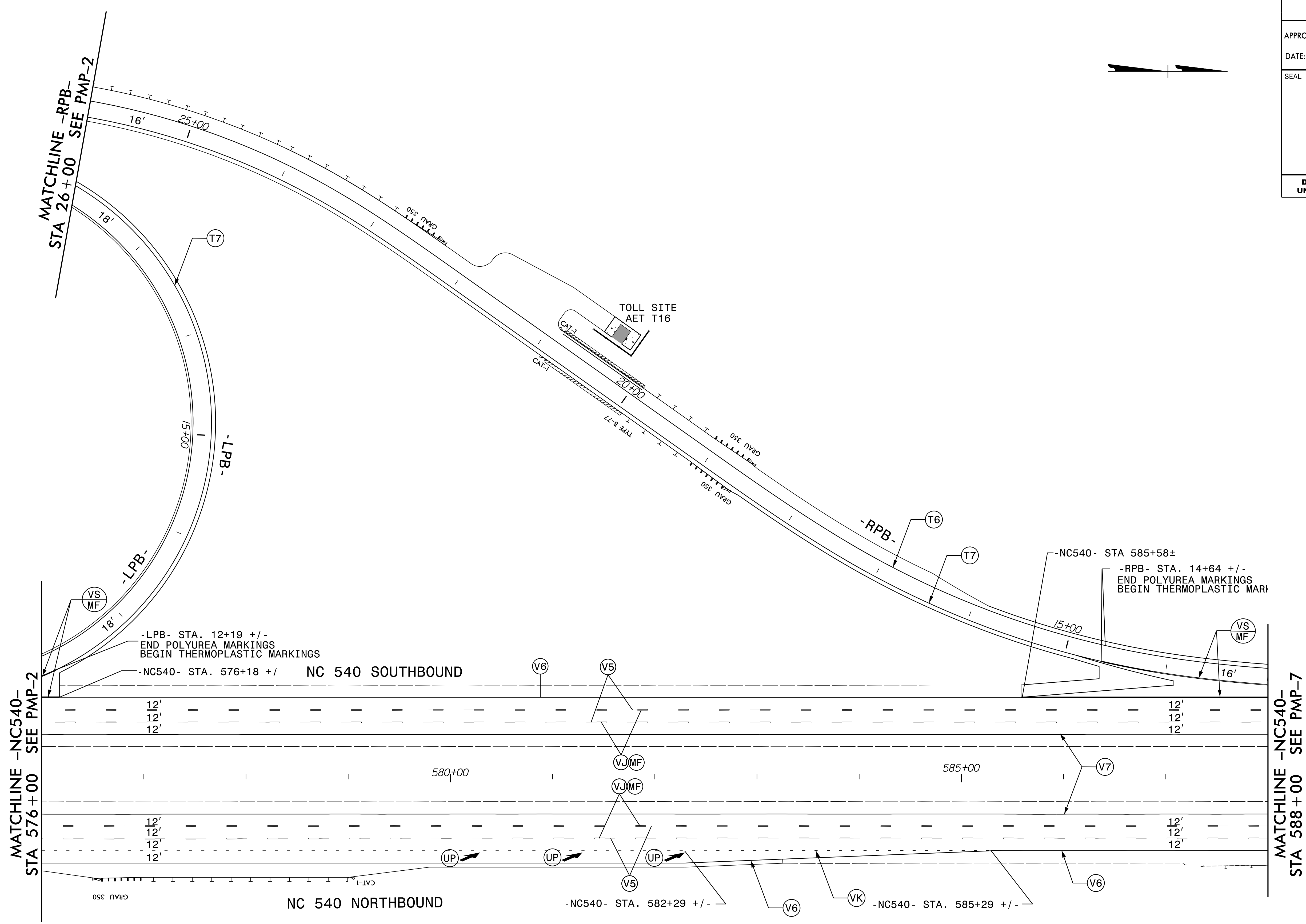

11/9/2017  
U-5315-imp-psr06.dgn  
c3eartls

PLANS PREPARED BY:



RUMMEL, KLEPPER & KAHL, LLP  
900 RIDGEFIELD DRIVE, SUITE 350  
RALEIGH, NORTH CAROLINA 27609  
NC LICENSE NO. F-0117  
1-888-521-4455 OR 919-878-9560

# PAVEMENT MARKING DETAIL

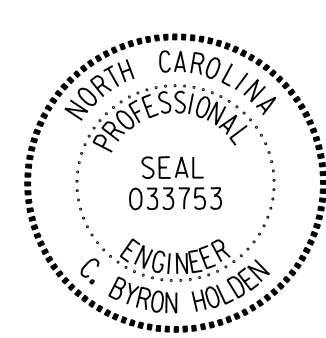

TIP NO. U-5315 A&B	SHEET NO. PMP-7
APPROVED: <i>C. Byron Holden</i> 11/11/2017	
DATE: 11/11/2017	
SEAL 	
DOCUMENT NOT CONSIDERED FINAL UNLESS ALL SIGNATURES COMPLETED	

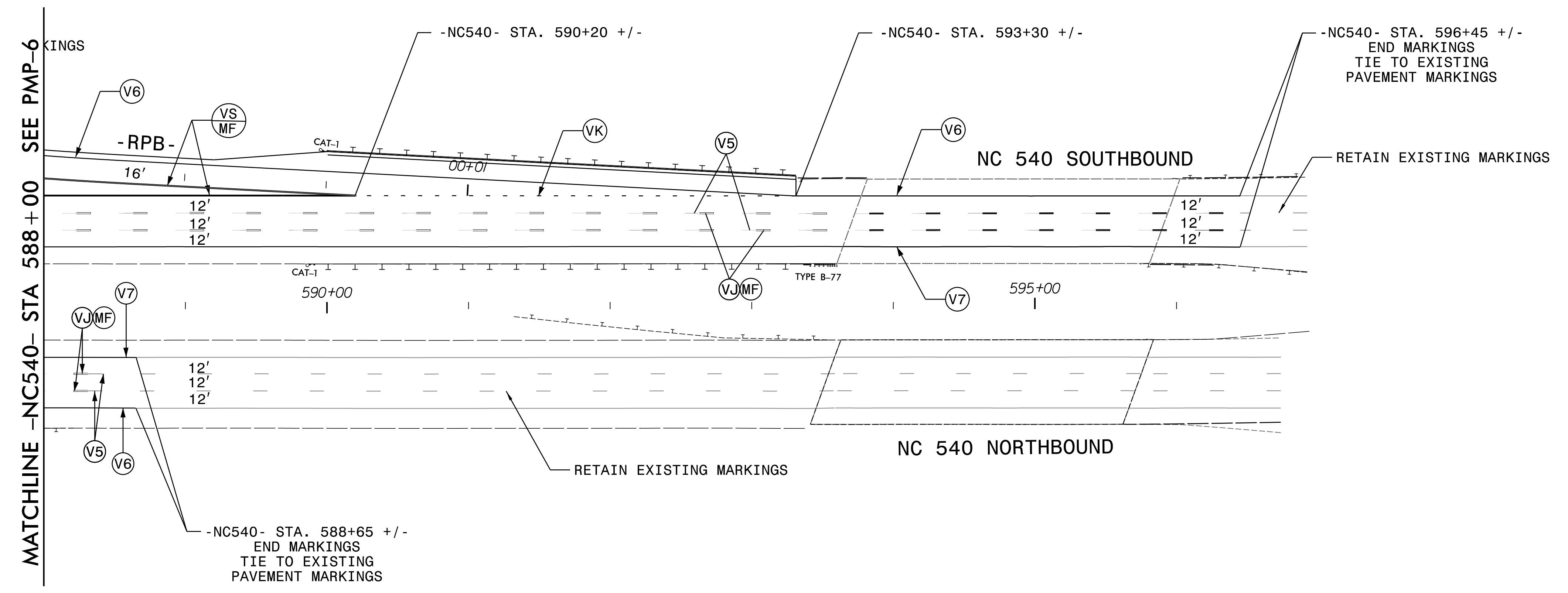
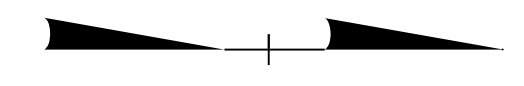

11/9/2017  
U-5315-imp-psr07.dgn  
c3e0r1s

PLANS PREPARED BY:



RUMMEL, KLEPPER & KAHL, LLP  
900 RIDGEFIELD DRIVE, SUITE 350  
RALEIGH, NORTH CAROLINA 27609  
NC LICENSE NO. F-0112  
1-888-521-4455 OR 919-878-9560

# PAVEMENT MARKING DETAIL

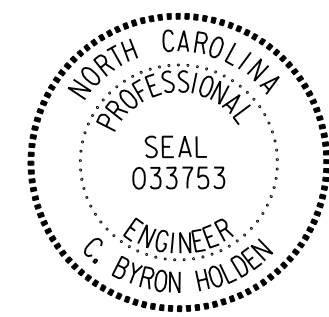
TIP NO.	SHEET NO.
U-5315 A&B	PMP-8
APPROVED: 	
DATE: 11/11/2017	
SEAL	
	
DOCUMENT NOT CONSIDERED FINAL UNLESS ALL SIGNATURES COMPLETED	

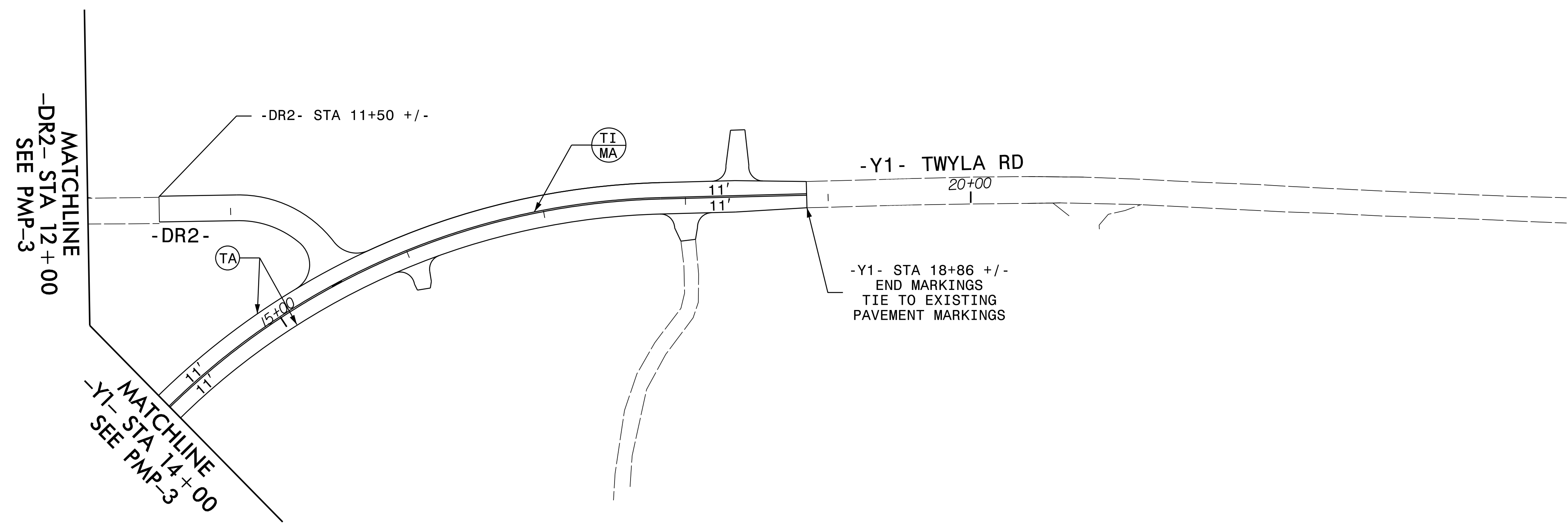
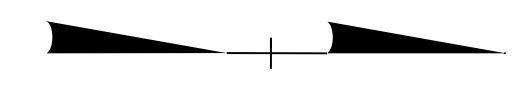

PLANS PREPARED BY:

**RK&K**

RUMMEL, KLEPPER & KAHL, LLP  
 900 RIDGEFIELD DRIVE, SUITE 350  
 RALEIGH, NORTH CAROLINA 27609  
 NC LICENSE NO. F-0112  
 1-888-521-4455 OR 919-878-9560

**PAVEMENT MARKING DETAIL**

11/9/2017  
 U:\315\_Pmp\_psh08.dgn  
 C:\Users\psh08\Documents