

**This electronic collection of documents is provided
for the convenience of the user
and is Not a Certified Document –**

**The documents contained herein were originally issued
and sealed by the individuals whose names and license
numbers appear on each page, on the dates appearing
with their signature on that page.**

**This file or an individual page
shall not be considered a certified document.**

STATE OF NORTH CAROLINA
DEPARTMENT OF TRANSPORTATION

CABARRUS COUNTY
SIGNING PLAN

LOCATION: CONCORD MILLS BOULEVARD, MALL ENTRANCE

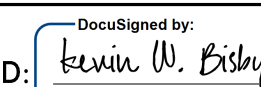
APPROVED: 
DATE: 11/15/2017



TIP PROJECT: U-5806

ROADWAY STANDARD DRAWINGS

THE FOLLOWING ROADWAY STANDARDS AS APPEAR IN "ROADWAY STANDARD DRAWINGS" - PROJECT SERVICES UNIT - N.C. DEPARTMENT OF TRANSPORTATION - RALEIGH, N.C., DATED JANUARY 2012 ARE APPLICABLE TO THIS PROJECT AND BY REFERENCE HEREBY ARE CONSIDERED A PART OF THESE PLANS:

STD. NO.	TITLE
901.10	TYPE 'A' SIGNS
901.20	TYPE 'B' SIGNS
901.50	ARROWS AND SHIELDS
901.70	SIGN STRINGERS AND SUPPORT SPACING
901.80	SIGN MOUNTING DETAILS - FOR TYPE A AND TYPE B SIGNS
903.10	GROUND MOUNTED SIGN SUPPORTS
904.10	ORIENTATION OF GROUND MOUNTED SIGNS
904.50	MOUNTING OF TYPE 'D', 'E', AND 'F' SIGNS ON 'U' CHANNEL POSTS
1264.01	OBJECT MARKERS - TYPES
1264.02	OBJECT MARKERS - INSTALLATION

PROJECT NOTES

- DISPOSAL OF SIGN SYSTEM, U-CHANNEL
- DISPOSAL OF SUPPORT, U-CHANNEL
- SIGN ERECTION, RELOCATE SIGN TYPE E

GENERAL NOTES

- SIGNS FURNISHED BY DEPARTMENT
- IF REMOVAL OR RELOCATION OF SIGNS ON PRIVATE STREET (NON-STATE MAINTAINED) IS REQUIRED DUE TO CONSTRUCTION, THE CONTRACTOR SHALL INFORM THE ENGINEER. THE WORK WILL BE COMPLETED BY OTHERS UNLESS OTHERWISE INDICATED ON THE PLAN.
- WHEN NOT STATIONED OR DIMENSIONED ON PLANS, ALL "E" AND "F" SIGNS SHALL BE FIELD LOCATED BY THE ENGINEER.
- RETAIN ALL EXISTING SIGNS UNLESS OTHERWISE NOTED.
- WHEN EXISTING SIGNS ARE TO BE RELOCATED, THE RELOCATION SHALL TAKE PLACE IMMEDIATELY FOLLOWING THE REMOVAL FROM THE EXISTING LOCATION.
- THE BACKGROUND FOR TYPE "E" SIGNS SHALL BE TYPE C REFLECTIVE SHEETING.
- LOCATE ALL UNDERGROUND UTILITIES BEFORE BEGINNING SIGN INSTALLATION WORK.
- DO NOT BEGIN FABRICATION FOR TYPE A AND B SIGNS MOUNTED ON OVERHEAD STRUCTURES OR STEEL SUPPORTS UNTIL "S" DIMENSIONS HAVE BEEN FIELD VERIFIED.
- SEE ROADWAY PLANS FOR GUARD/GUIDE RAIL DETAILS.

SUMMARY OF QUANTITIES

ITEM NO.		ITEM DESCRIPTION	QUANTITY	UNIT
DESC. NO.	SECT. NO.			
4054000000	902	PLAIN CONCRETE SIGN FOUNDATION	1	C.Y.
4057000000	SP	OVERHEAD FOOTING	71	C.Y.
4060000000	903	SUPPORTS, BREAKAWAY STEEL BEAM	216	LB.
4072000000	903	SUPPORTS, 3 LB STEEL U-CHANNEL	300	L.F.
4082100000	SP	SUPPORTS, OVERHEAD SIGN STRUCTURE AT STATION 34+92	1	L.S.
4370000000	SP	SUPPORTS, OVERHEAD SIGN STRUCTURE AT WB CONCORD MILLS AT I-85 SB LOOP GORE	1	L.S.
4370000000	SP	SUPPORTS, OVERHEAD SIGN STRUCTURE AT WB BRUTON SMITH EAST OF I-85 NB RAMPS	1	L.S.
4370000000	SP	SUPPORTS, OVERHEAD SIGN STRUCTURE AT I-85 SB EXIT RAMP B/T LOGO SIGNS	1	L.S.
4102000000	904	SIGN ERECTION, TYPE E	24	EA.
4109000000	904	SIGN ERECTION, TYPE A (OVERHEAD)	11	EA.
4110000000	904	SIGN ERECTION, TYPE A (GROUND MOUNTED)	1	EA.
4116100000	904	SIGN ERECTION, RELOCATE SIGN TYPE E	3	EA.
4155000000	907	DISPOSAL OF SIGN SYSTEM, U-CHANNEL	23	EA.
4192000000	907	DISPOSAL OF SUPPORT, U-CHANNEL	3	EA.

CONTRACT:

PLAN PREPARED FOR: N.C.D.O.T. SIGNING AND DELINEATION UNIT AND DESIGN BUILD UNIT

K. L. JORDAN SIGNING & DELINEATION REGIONAL ENGINEER
D. H. BEARD SIGNING & DELINEATION PROJECT DESIGN ENGINEER

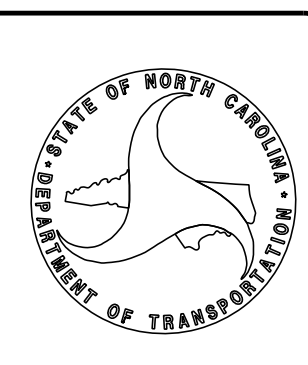

PLANS PREPARED BY :
RK&K
RUMMEL, KLEPPER & KAHL, LLP
900 RIDGEFIELD DRIVE SUITE 350
RALEIGH, NORTH CAROLINA 27609-3960
NC LICENSE NO. F-0112 (919) 878-9560

INDEX

SHEET NO.	DESCRIPTION
SIGN-1	TITLE SHEET
SIGN-2 THRU SIGN-2B	SUPPORT INFORMATION, DETAILS TO BE USED IN LIEU OF ROADWAY STANDARD DRAWINGS
SIGN-3	TYPE "E" SIGNS
SIGN-4 THRU SIGN-4C	SIGN DESIGNS
SIGN-5 THRU SIGN-5C	OVERHEAD STRUCTURE LINE DRAWINGS
SIGN-6 THRU SIGN-10	SIGNING PLAN SHEETS

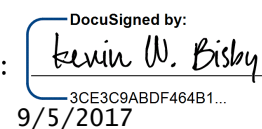
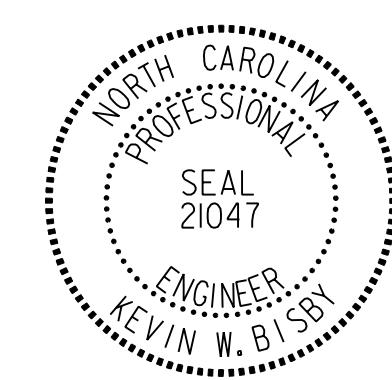
DOCUMENT NOT CONSIDERED FINAL UNLESS ALL SIGNATURES COMPLETED	PROJECT REFERENCE NO.	SHEET NO.
	U-5806	SIGN-2
APPROVED: 		
DATE: 9/5/2017		
SEAL		
		

Version: 3.0 Posted: 9/14/2016

SIGN					ROADWAY STATION	NUMBER OF SUPPORTS	BEAM SECTION	SUPPORT TYPE BA or S	OMNI COUPLER	ATTACHMENT METHOD	MOUNTING METHOD	HORIZONTAL CLEARANCE* (ft.)	SUPPORT SPACING	LENGTH (ft)			LEFT SUPPORT (ft)			CENTER SUPPORT (ft)			RIGHT SUPPORT (ft)			SUPPORT WEIGHTS		FOOTINGS				FIELD VERIFIED SEE NOTE 2 (mm/dd/yy)
NUMBER	TYPE	SIZE (in.)												SNS HT "H"	MTG HT "C"	EMBED-MENT	S	L	LENGTH	S	L	LENGTH	S	L	LENGTH	B/A (lbs.)	SIMPLE (lbs.)	DIAMETER (ft.)	DEPTH (ft.)	REINFORCED (c.y.)	PLAIN (c.y.)	
		w	x	h																												
201	A	72	x	60	I-85 SB LOOP GORE	2	S3x5.7	BA	N/A	N/A	N/A	Δ	3.52	5.00	7.00	2.5	1.00	13.00	15.50	0.00	0.00	0.00	1.50	13.50	16.00	215.55	0	1.0	3	0.00	0.17	
																	TOTAL	TOTAL		TOTAL	TOTAL											
																	215.55	0.00		0.00	0.17											
																	USE:	216.00	0.00		0.00	1.00										

NOTES

- DIMENSION "S" REPRESENTS AN INCREASE (+), OR A DECREASE (-) IN POLE LENGTH, RELATIVE TO THE ELEVATION OF THE EDGE OF PAVEMENT.
- FIELD VERIFICATIONS SHALL BE REQUIRED FOR ALL SUPPORTS, SEE (*) ARTICLE 903-3. FABRICATORS SHALL BE AISC CERTIFIED IN CATEGORY 1, SEE (*) ARTICLE 1072-1. (*) = N.C.D.O.T. STANDARD SPECIFICATIONS FOR ROADS AND STRUCTURES
- PLAN LOCATIONS FOR EXISTING UTILITIES ARE BASED ON THE BEST AVAILABLE INFORMATION AND, THEREFORE MAY NOT BE PRECISELY ACCURATE. THEREFORE, IT IS INCUMBENT UPON THE CONTRACTOR TO DETERMINE THE EXACT LOCATION OF UTILITIES BEFORE BEGINNING WORK IN A LOCATION.

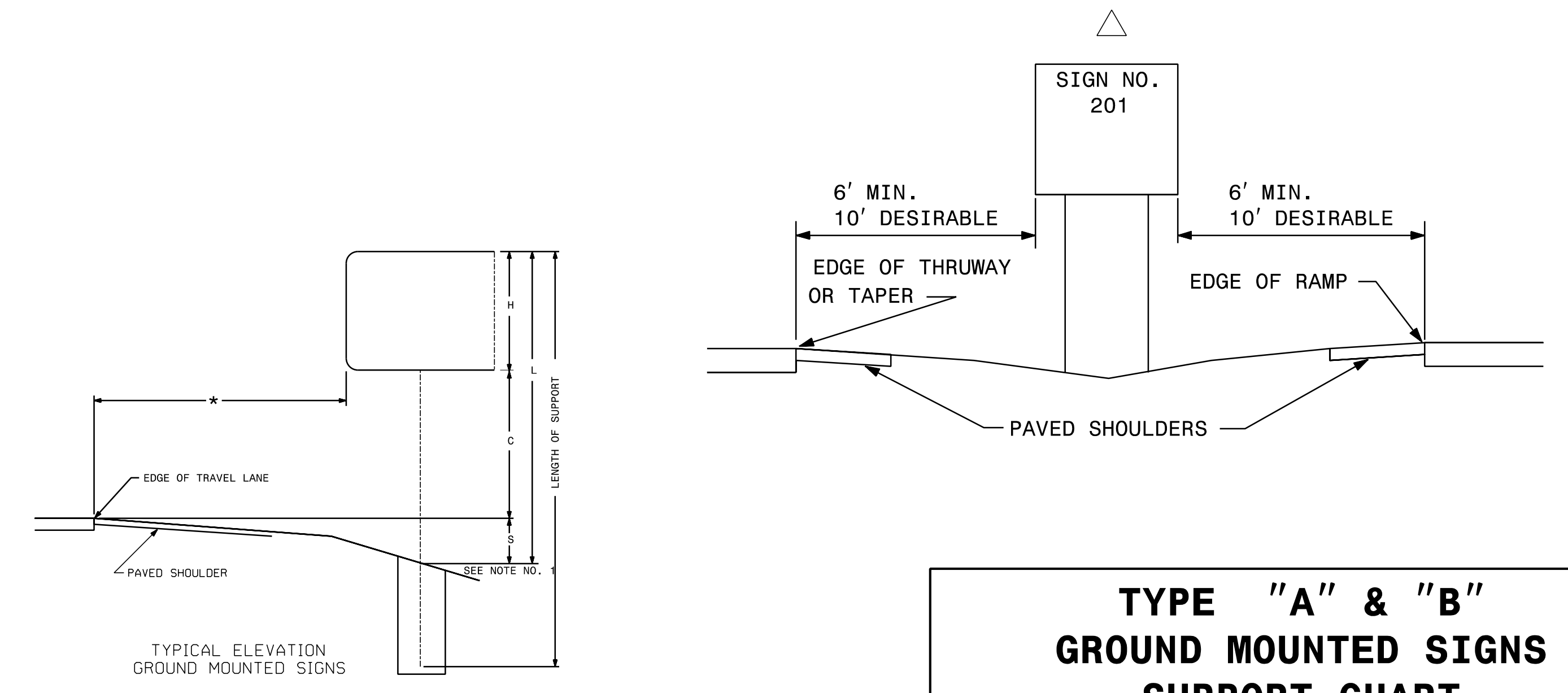

**TYPE "A" & "B"
GROUND MOUNTED SIGNS
SUPPORT CHART**

9/5/2017 R5806-SGN-SUPPORT CHART.dgn

APPROVED: *Kevin W. Bishop*
DATE: 9/5/2017
SEAL

TIP NO. SHEET NO.
APPROVED: *PLW*
DATE: 7/26/13
SEAL



STATE OF NORTH CAROLINA
DEPT. OF TRANSPORTATION
DIVISION OF HIGHWAYS
RALEIGH, N.C.

ENGLISH STANDARD DRAWING FOR
GROUND MOUNTED SIGN SUPPORTS

SHEET 1 OF 3
903D10

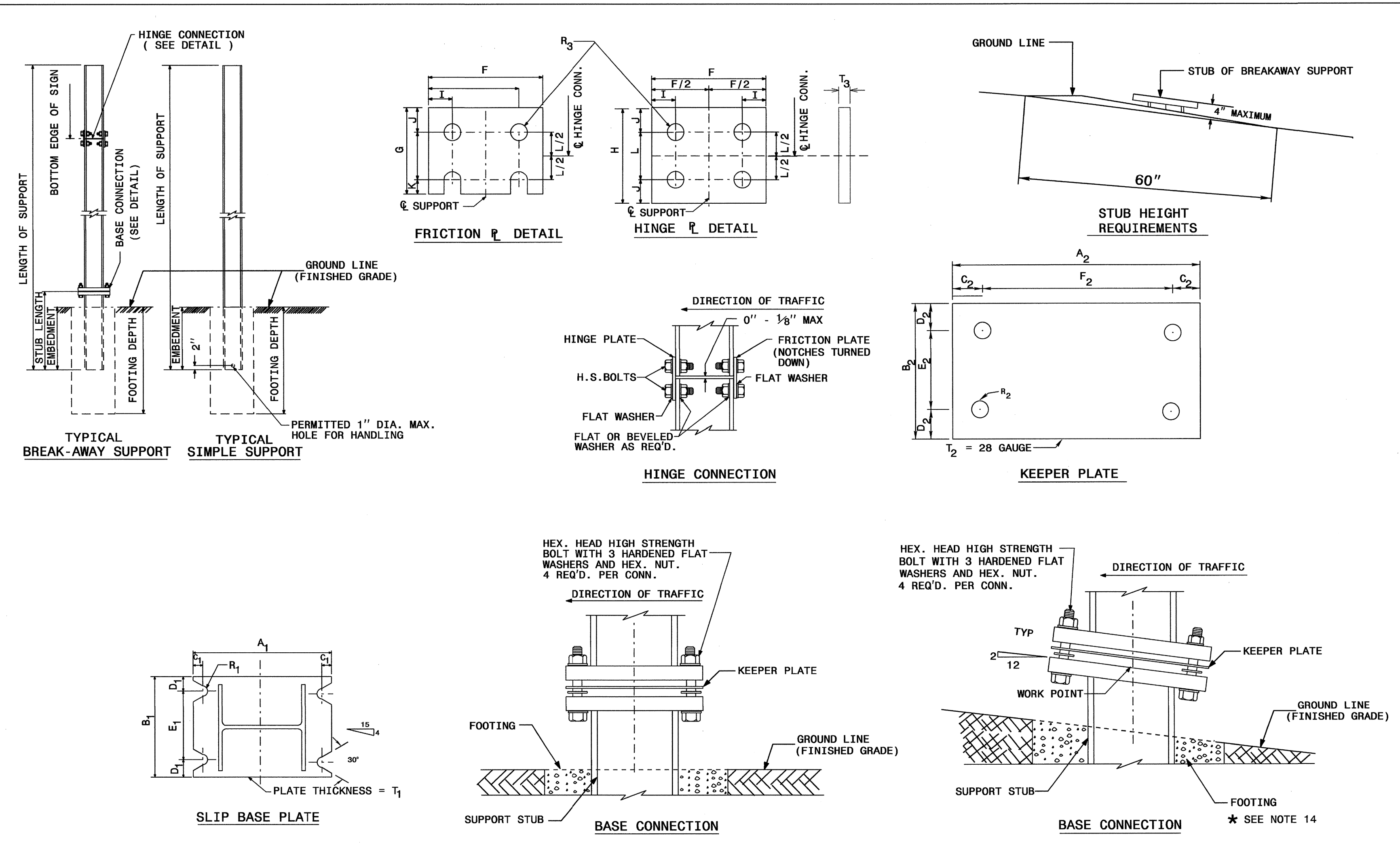

SEE SHEET 2 OF 3 FOR
BASE CONNECTION DATA
HINGE CONNECTION DATA
& FOUNDATION DATA.
SEE SHEET 3 OF 3 FOR
GENERAL NOTES.

STATE OF NORTH CAROLINA
DEPT. OF TRANSPORTATION
DIVISION OF HIGHWAYS
RALEIGH, N.C.

ENGLISH STANDARD DRAWING FOR
GROUND MOUNTED SIGN SUPPORTS

SHEET 1 OF 3
903D10

REVISED SIGNING
ROADWAY STANDARD DRAWING

26-JUL-2015 09:37
S:\SDD\Standards\Drawings\Drawings\2012 Standard Dwg\Division 9 Final\090310_sgn_sht01.dgn support-2A.dgn
158065_SGN_psh-2A.dgn

PLANS PREPARED BY :
RK&K
RUMMEL, KLEPPER & KAHL, LLP
900 RIDGEFIELD DRIVE SUITE 350
RALEIGH, NORTH CAROLINA 27609-3960
NC LICENSE NO. F-0112 • (919) 878-9560

APPROVED: *Kevin W. Bishop*
DATE: 9/5/2017

SEAL

TIP NO. SHEET NO.

APPROVED: *RWT*
DATE: 7/26/13

SEAL



STATE OF NORTH CAROLINA
DEPT. OF TRANSPORTATION
DIVISION OF HIGHWAYS
RALEIGH, N.C.

ENGLISH DETAIL DRAWING FOR
GROUND MOUNTED SIGN SUPPORTS

SHEET 2 OF 3
903D10

BEAM SHAPE	BOLT SIZE	SLIP BASE PLATE DATA								KEEPER PLATE DATA								HINGE CONNECTION DATA								BOLT SIZE	F	G	H	I	J	K	L	R ₃	T ₃	BREAK AWAY SUPPORT WEIGHT CONSTANT LBS.
		A ₁	B ₁	C ₁	D ₁	E ₁	T ₁	R ₁	A ₂	B ₂	C ₂	D ₂	E ₂	R ₂	T ₂																					
S3X5.7	1/2"DIA. X 3/4"	7"	4"	1"	3/4"	2 1/2"	1"	9/32"	7"	4"	1"	3/4"	2 1/2"	9/32"	28 GAUGE	1/2"DIA. X 1 3/4"	2 1/4"	3 1/2"	4"	1 1/2"	1"	1 1/2"	2"	9/32"	3/8"	18										
S4X7.7	1/2"DIA. X 3/4"	8"	4"	1"	3/4"	2 1/2"	1"	9/32"	8"	4"	1"	3/4"	2 1/2"	9/32"	28 GAUGE	1/2"DIA. X 1 3/4"	2 5/8"	3 1/2"	4"	1 1/2"	1"	1 1/2"	2"	9/32"	3/8"	20										
W6X9	1/2"DIA. X 3/4"	10"	5"	1"	3/4"	3 1/2"	1"	9/32"	10"	5"	1"	3/4"	3 1/2"	9/32"	28 GAUGE	1/2"DIA. X 1 3/4"	4"	3 1/2"	4"	3/4"	1"	1 1/2"	2"	9/32"	3/8"	32										
W6X12	5/8"DIA. X 4"	11"	5"	1 1/4"	7/8"	3 1/4"	1 1/4"	11/32"	11"	5"	1 1/4"	7/8"	3 1/4"	11/32"	28 GAUGE	5/8"DIA. X 2"	4"	4"	4 1/2"	3/4"	1 1/8"	5/8"	2 1/4"	11/32"	3/8"	39										
W6X16	5/8"DIA. X 4 1/2"	12"	6"	1 1/4"	7/8"	4 1/4"	1 1/2"	11/32"	12"	6"	1 1/4"	7/8"	4 1/4"	11/32"	28 GAUGE	5/8"DIA. X 2 1/4"	4"	4"	4 1/2"	3/4"	1 1/8"	5/8"	2 1/4"	11/32"	3/8"	47										
W8X18	5/8"DIA. X 4 1/2"	13 1/2"	6 1/2"	1 1/4"	7/8"	4 3/4"	1 1/2"	11/32"	13 1/2"	6 1/2"	1 1/4"	7/8"	4 3/4"	11/32"	28 GAUGE	5/8"DIA. X 2 1/4"	5 1/4"	4"	4 1/2"	1"	1 1/8"	5/8"	2 1/4"	11/32"	3/8"	70										
W8X21	3/4"DIA. X 4 1/2"	14"	7"	1 1/2"	1"	5"	1 1/2"	13/32"	14"	7"	1 1/2"	1"	5"	13/32"	28 GAUGE	3/4"DIA. X 2 1/2"	5 1/4"	6"	7"	1"	1 3/4"	3/4"	3 1/2"	13/32"	3/8"	73										
W10X22	3/4"DIA. X 4 1/2"	16"	8"	1 1/2"	1"	6"	1 1/2"	13/32"	16"	8"	1 1/2"	1"	6"	13/32"	28 GAUGE	3/4"DIA. X 2 1/2"	5 3/4"	6"	7"	1"	1 3/4"	3/4"	3 1/2"	13/32"	3/8"	119										
W10X26	3/4"DIA. X 5 1/2"	16 1/2"	8"	1 1/2"	1"	6"	1 3/4"	13/32"	16 1/2"	8"	1 1/2"	1"	6"	13/32"	28 GAUGE	3/4"DIA. X 2 3/4"	5 3/4"	6"	7"	1"	1 3/4"	3/4"	3 1/2"	13/32"	5/8"	140										
W12X26	3/4"DIA. X 5 1/2"	18 1/2"	9"	1 1/2"	1"	7"	1 3/4"	13/32"	18 1/2"	9"	1 1/2"	1"	7"	13/32"	28 GAUGE	3/4"DIA. X 2 3/4"	6 1/2"	6"	7"	1"	1 3/4"	3/4"	3 1/2"	13/32"	5/8"	176										
W14X30	1"DIA. X 6"	22"	9"	2"	1 1/2"	6"	2"	17/32"	22"	9"	2"	1 1/2"	6"	17/32"	28 GAUGE	1"DIA. X 3"	6 3/4"	7"	8"	1 1/4"	2"	1"	4"	17/32"	5/8"	205										
W16X31	1"DIA. X 6"	24"	9"	2"	1 1/2"	6"	2"	17/32"	24"	9"	2"	1 1/2"	6"	17/32"	28 GAUGE	1"DIA. X 3"	5 1/2"	7"	8"	1 1/4"	2"	1"	4"	17/32"	3/4"	223										
W18X35	1"DIA. X 6"	25"	9"	2"	1 1/2"	6"	2"	17/32"	25"	9"	2"	1 1/2"	6"	17/32"	28 GAUGE	1"DIA. X 3"	6"	7"	8"	1 1/4"	2"	1"	4"	17/32"	3/4"	243										
W18X40	1"DIA. X 6 1/2"	26"	9"	2"	1 1/2"	6"	2 1/4"	17/32"	26"	9"	2"	1 1/2"	6"	17/32"	28 GAUGE	1"DIA. X 3 1/2"	6"	7"	8"	1 1/4"	2"	1"	4"	17/32"	7/8"	278										
W21X44	1"DIA. X 7"	29"	9"	2"	1 1/2"	6"	2 1/2"	17/32"	29"	9"	2"	1 1/2"	6"	17/32"	28 GAUGE	1"DIA. X 3 1/2"	6 1/2"	7"	8"	1 1/4"	2"	1"	4"	17/32"	7/8"	310										

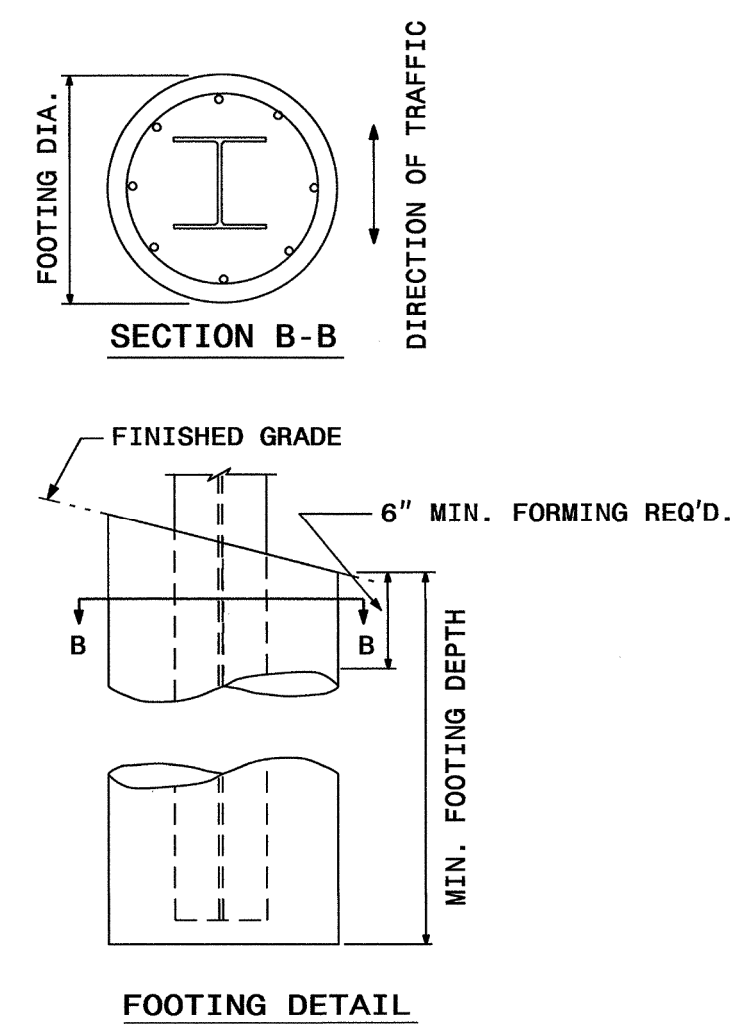
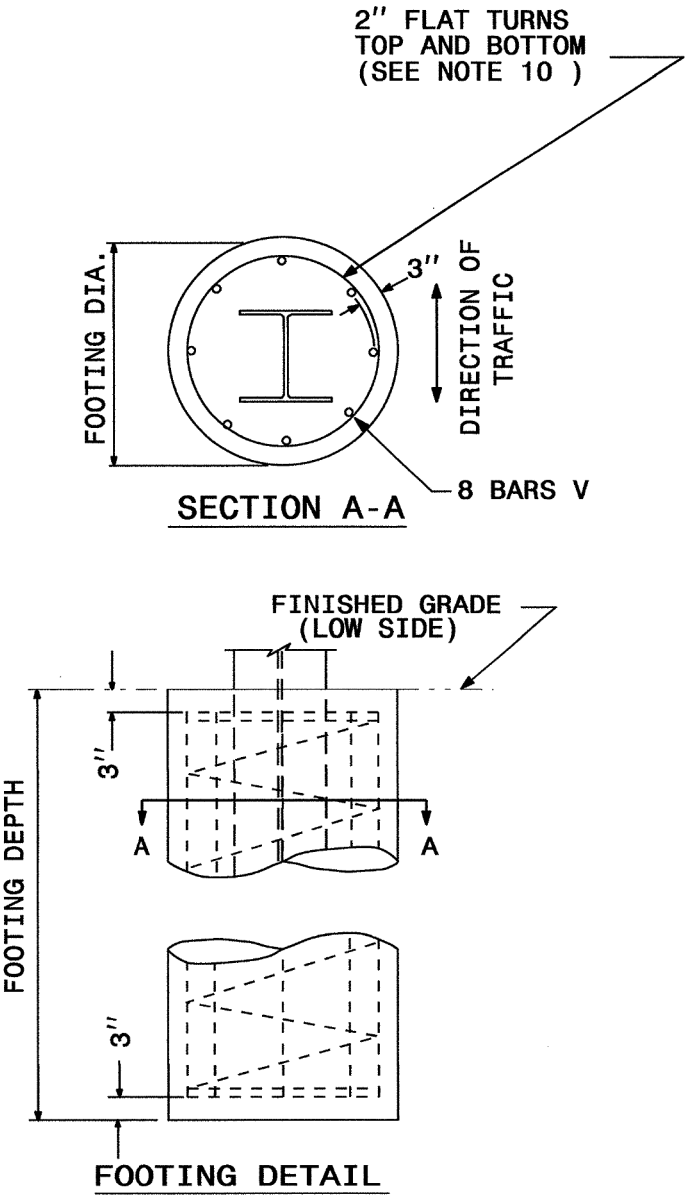

FOUNDATION DATA *		
FOOTING DIAMETER	REINFORCEMENT	SPIRAL BAR
1'-6"	8 # 6 BARS	#3 BAR, 6" PITCH
2'	8 # 7 BARS	#3 BAR, 6" PITCH
2'-6"	8 # 9 BARS	#3 BAR, 6" PITCH
3'	8 # 11 BARS	#3 BAR, 6" PITCH
3'-6"	8 # 12 BARS	#3 BAR, 6" PITCH
4'	8 # 14 BARS	#3 BAR, 6" PITCH

* FOUNDATION DIMENSIONS ARE SHOWN IN PLANS

STATE OF NORTH CAROLINA
DEPT. OF TRANSPORTATION
DIVISION OF HIGHWAYS
RALEIGH, N.C.









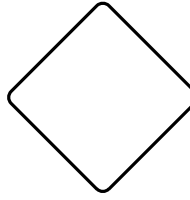

ENGLISH DETAIL DRAWING FOR
GROUND MOUNTED SIGN SUPPORTS

SHEET 2 OF 3
903D10

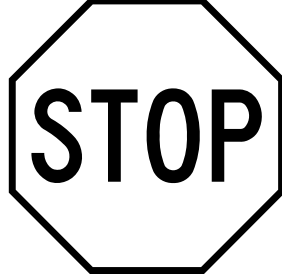
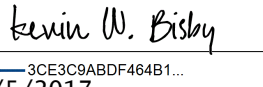
REVISED SIGNING
ROADWAY STANDARD DRAWING

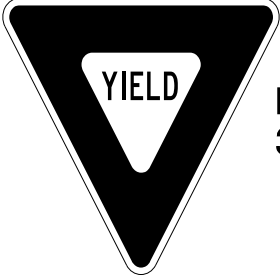
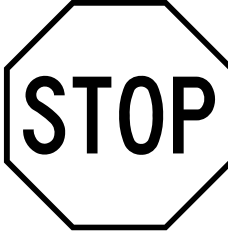
26-JUL-2013 09:50 ST:\30301\Standards\Drawings\Drawings\2012 Standard Dwg\Division 9 Find\090310_sgn_sht02.gm support+Revised_7-3-13.dgn

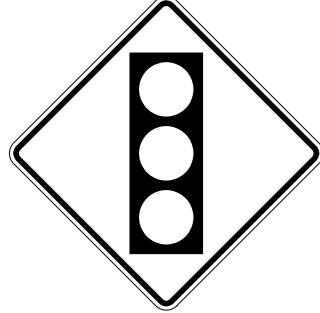
PLANS PREPARED BY :
RK&K
RUMMEL, KLEPPER & KAHL, LLP
900 RIDGEFIELD DRIVE SUITE 350
RALEIGH, NORTH CAROLINA 27609-3960
NC LICENSE NO. F-0112 • (919) 878-9560

DOCUMENT NOT CONSIDERED FINAL UNLESS ALL SIGNATURES COMPLETED					PROJECT REFERENCE NO. U-5806	SHEET NO. SIGN-3
<p>401 QUANTITY REQ'D 4</p>  <p>R2-1 30"X36"</p> <p>ONE "U" POST PER SIGN</p>	<p>402 QUANTITY REQ'D 4</p>  <p>R4-7 24"X30"</p> <p>ONE "U" POST PER SIGN</p>	<p>403 QUANTITY REQ'D 4</p>  <p>OM1-3 18"X18"</p> <p>MOUNT BELOW SIGN 402 IN FOUR INSTALLATIONS</p>	<p>404 QUANTITY REQ'D 2</p>  <p>R3-7 36"X36"</p> <p>ONE "U" POST PER SIGN</p>	<p>405 QUANTITY REQ'D 2</p>  <p>R1-1 36"X36"</p> <p>ONE "U" POST PER SIGN</p>	<p>APPROVED: </p> <p>DATE: 9/5/2017</p> <p>SEAL</p> 	
<p>406 QUANTITY REQ'D 1</p>  <p>R1-2 36"X36"X36"</p> <p>ONE "U" POST PER SIGN</p>	<p>407 QUANTITY REQ'D 3</p>  <p>R1-1 30"X30"</p> <p>ONE "U" POST PER SIGN</p>	<p>408 QUANTITY REQ'D 1</p>  <p>M5-4 24"X18"</p> <p>MOUNT BELOW SIGN 407 IN ONE INSTALLATION</p>	<p>409 QUANTITY REQ'D 1</p>  <p>W3-3 30"X30"</p> <p>ONE "U" POST PER SIGN</p>	<p>410 QUANTITY REQ'D 1</p> <p>Thunder Rd</p> <p>W16-8aP 30"X15"</p> <p>MOUNT BELOW SIGN 410 IN ONE INSTALLATION. SEE SHEET SIGN-4C FOR SIGN DESIGN</p>	<p>411 QUANTITY REQ'D 1</p>  <p>R3-8 Rev. 30"X30"</p> <p>ONE "U" POST PER SIGN. SEE SHEET SIGN-4C FOR SIGN DESIGN.</p>	
<p>PLANS PREPARED BY :</p>  <p>RUMMEL, KLEPPER & KAHL, LLP 900 RIDGEFIELD DRIVE SUITE 350 RALEIGH, NORTH CAROLINA 27609-3960 NC LICENSE NO. F-0112 • (919) 878-9560</p>					<p>TYPE "E" SIGNS</p>	

9/5/2017 9:58:06 AM U-5806 SIGN-E SHEETS.dgn

\$DATE\$
 \$FILE\$
 \$JOB\$

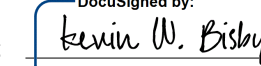
APPROVED: 
 DATE: 9/5/2017

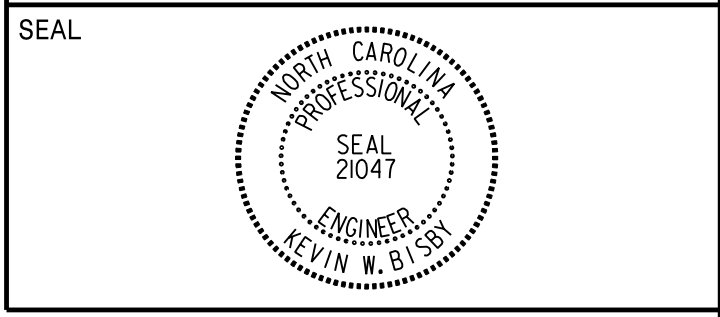

SIGN NUMBER: 1 TYPE: A QUANTITY: 1 SIGN WIDTH: 12'-0" HEIGHT: 9'-6" TOTAL AREA: 114.0 Sq.Ft. BORDER TYPE: FLUSH RECESS: 0" WIDTH: 2" RADII: 12" NO. Z BARS: 3 LENGTH: 136.0	BACKG COLOR: Green COPY COLOR: White SYMBOL X Y WID HT W1_1 16.5 61.2 36 36	DESIGN BY: K. BISBY PROJECT ID: U-5806	CHECKED BY: D. SEARS LOCATION: -L- STA 34+94.10	May 03, 2017 DIV: 10
--	--	---	--	-------------------------

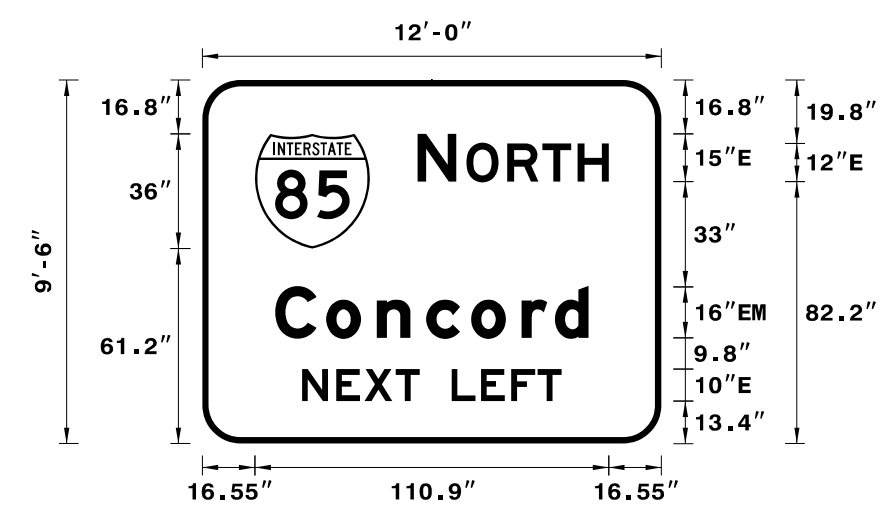

Spacing Factor is 1 unless specified otherwise

Letter positions										Series/Size	
Letter spacings are to start of next letter										Text Length	
N	O	R	T	H						E 2000	
67.5	12.2	3.1	12.8	11	11	9.7	16.3			59.9	
C	O	N	C	R	D					EM 2000	
22.9	16	15.8	15.5	14.1	15.8	10.4	10.6	22.9		98.2	
N	E	X	T	L	E	F	T			E 2000	
31.3	10.7	8.9	9.8	7.5	10	9.2	9.5	8.3	7.5	31.3	81.4

FILENAME: U5806_SIGN_DESIGN_PSH NORTH CAROLINA D.O.T. SIGN DETAIL

SIGN NUMBER: 2 TYPE: A QUANTITY: 1 SIGN WIDTH: 12'-6" HEIGHT: 11'-6" TOTAL AREA: 143.8 Sq.Ft. BORDER TYPE: FLUSH RECESS: 0" WIDTH: 2" RADII: 12" NO. Z BARS: 3 LENGTH: 142.0	BACKG COLOR: Green COPY COLOR: White SYMBOL X Y WID HT W1_1 19.6 88.5 36 36 R3-5r 60.0 12.5 30 36	DESIGN BY: K. BISBY PROJECT ID: U-5806	CHECKED BY: D. SEARS LOCATION: -L- STA 34+94.10	Jun 07, 2017 DIV: 10
---	---	---	--	-------------------------

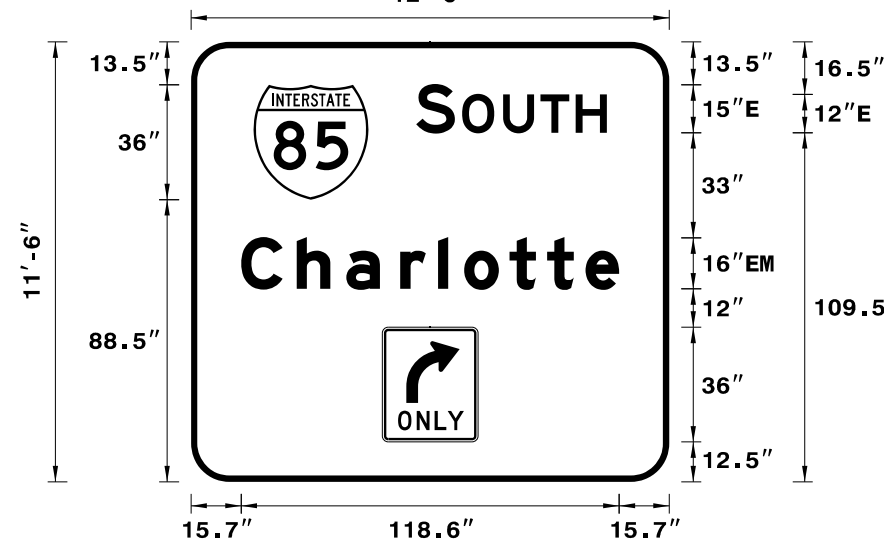

Spacing Factor is 1 unless specified otherwise

Letter positions										Series/Size	
Letter spacings are to start of next letter										Text Length	
S	O	U	T	H						E 2000	
70.6	12.2	2.2	12.8	11.8	11	9.7	19.6			59.8	
C	H	A	R	L	O	T	E			EM 2000	
15.7	17.4	15.5	17	11.8	8.2	14.2	11.8	12	10.6	15.7	118.6

FILENAME: U5806_SIGN_DESIGN NORTH CAROLINA D.O.T. SIGN DETAIL

SIGN NUMBER: 3 TYPE: A QUANTITY: 1 SIGN WIDTH: 12'-0" HEIGHT: 9'-0" TOTAL AREA: 108.0 Sq.Ft. BORDER TYPE: FLUSH RECESS: 0" WIDTH: 2" RADII: 12" NO. Z BARS: 3 LENGTH: 136.0	BACKG COLOR: Green COPY COLOR: White SYMBOL X Y WID HT ARDOWN 56 14 32 22	DESIGN BY: K. BISBY PROJECT ID: U-5806	CHECKED BY: D. SEARS LOCATION: -L- STA 34+94.10	May 03, 2017 DIV: 10
--	--	---	--	-------------------------

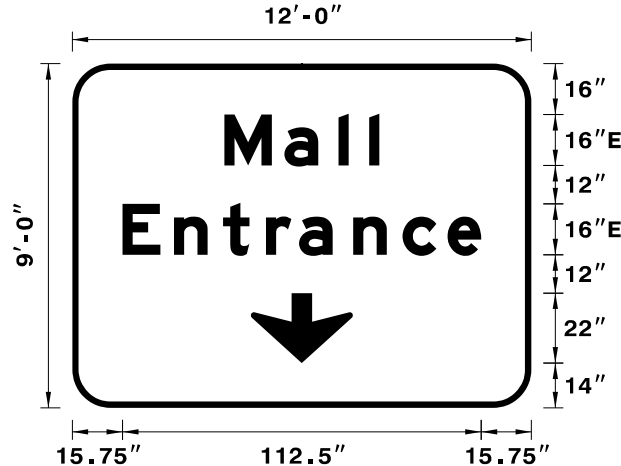

Spacing Factor is 1 unless specified otherwise

Letter positions										Series/Size
Letter spacings are to start of next letter										Text Length
M	a	l	l							EM 2000
47.7	18.9	17	9.6	3.2	47.7					48.6
E	n	t	r	a	n	c	e			EM 2000
15.8	16.2	15.4	13.4	10.4	17	15.5	14.1	10.6	15.8	112.5

FILENAME: U5806_SIGN_DESIGN_PSH NORTH CAROLINA D.O.T. SIGN DETAIL

SIGN NUMBER: 4 TYPE: A QUANTITY: 1 SIGN WIDTH: 19'-0" HEIGHT: 6'-0" TOTAL AREA: 114.0 Sq.Ft. BORDER TYPE: FLUSH RECESS: 0" WIDTH: 2" RADII: 9" NO. Z BARS: 2 LENGTH: 220.0	BACKG COLOR: Green COPY COLOR: White SYMBOL X Y WID HT	DESIGN BY: K. BISBY PROJECT ID: U-5806	CHECKED BY: D. SEARS LOCATION: -L- STA 34+94.10	May 04, 2017 DIV: 10
---	--	---	--	-------------------------

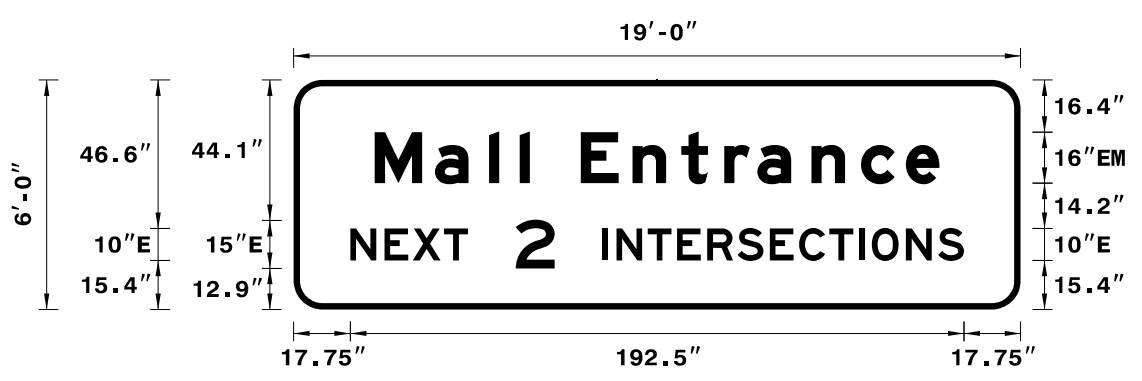

Spacing Factor is 1 unless specified otherwise

Letter positions										Series/Size												
Letter spacings are to start of next letter										Text Length												
M	a	l	l	E	n	t	r	a	n	c	e	EM 2000										
25.4	18.9	17	9.6	3.2	16	16.2	15.4	13.4	10.4	17	15.5	14.1	10.6	25.4	177.1							
N	E	X	T	2	I	N	T	E	R	S	E	C	T	I	O	N	S	E 2000				
17.8	10.7	8.9	9.8	7.5	15	12.2	15	4.4	9.8	9.2	9.5	9.5	10.1	9.2	9.5	9.2	4.1	10.7	10.1	8.1	17.8	192.5

FILENAME: U5806_SIGN_DESIGN NORTH CAROLINA D.O.T. SIGN DETAIL

05/03/2017
 U5806_SIGN_DESIGN_PSH.dgn

PLANS PREPARED BY :

 RUMMEL, KLEPPER & KAHL, LLP
 900 RIDGEFIELD DRIVE SUITE 350
 RALEIGH, NORTH CAROLINA 27609-3960
 NC LICENSE NO. F-0112 (919) 878-9560

SIGN DESIGNS

SIGN NUMBER: 5,7 TYPE: A QUANTITY: 2 SIGN WIDTH: 9'-6" HEIGHT: 8'-0" TOTAL AREA: 76.0 Sq.Ft. BORDER TYPE: FLUSH RECESS: 0" WIDTH: 2" RADII: 12" NO. Z BARS: 3 LENGTH: 106.0	BACKG COLOR: Green COPY COLOR: White SYMBOL X Y WID HT M1_1 21.8 44 36 36 AR_Type A 152.3 34.2 22.3 35	DESIGN BY: K. BISBY PROJECT ID: U-5806 LOCATION: CONCORD MILLS BLVD AT I-85 SB ENTRANCE LOOP GORE BRUTON SMITH BLVD '250' EAST OF I-85 NB RAMPS CHECKED BY: D. SEARS MAY 03, 2017 DIV: 10
--	--	---

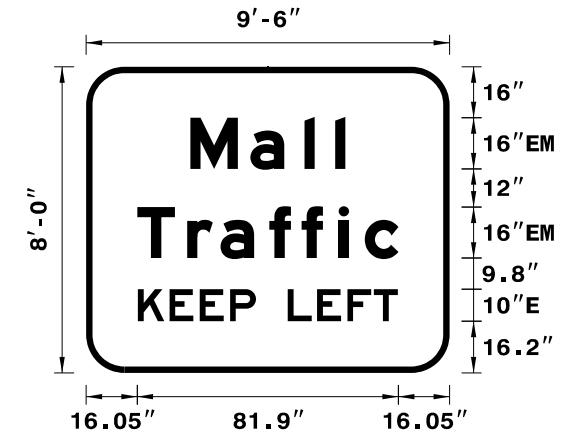

USE NOTES: 1,2
 1. Legend and border(except those that are colored black) shall be direct applied Grade A sheeting.
 2. Background shall be Grade C reflective sheeting.
 3. Shields: A, B, and C type arrows shall be on 0.032" (0.8mm) aluminum and demountable.

LETTER POSITIONS

Letter spacings are to start of next letter											Series/Size
N	a	l	l								Text Length
32.7	18.9	17	9.6	3.2	32.7						EM 2000 48.6
16	15.7	10.4	15.4	10.1	11.7	8.2	10.6	16			EM 2000 51.9
	K	E	E	P	L	E	F	T			E 2000 81.5

FILENAME: U5806_SGN_DESIGN_PSH NORTH CAROLINA D.O.T. SIGN DETAIL

SIGN NUMBER: 6 TYPE: A QUANTITY: 1 SIGN WIDTH: 16'-6" HEIGHT: 8'-0" TOTAL AREA: 132.0 Sq.Ft. BORDER TYPE: FLUSH RECESS: 0" WIDTH: 2" RADII: 12" NO. Z BARS: 3 LENGTH: 190.0	BACKG COLOR: Green COPY COLOR: White SYMBOL X Y WID HT M1_1 21.8 44 36 36 AR_Type A 152.3 34.2 22.3 35	DESIGN BY: K. BISBY PROJECT ID: U-5806 LOCATION: CONCORD MILLS BLVD AT I-85 SB ENTRANCE LOOP GORE CHECKED BY: D. SEARS MAY 03, 2017 DIV: 10
--	--	--

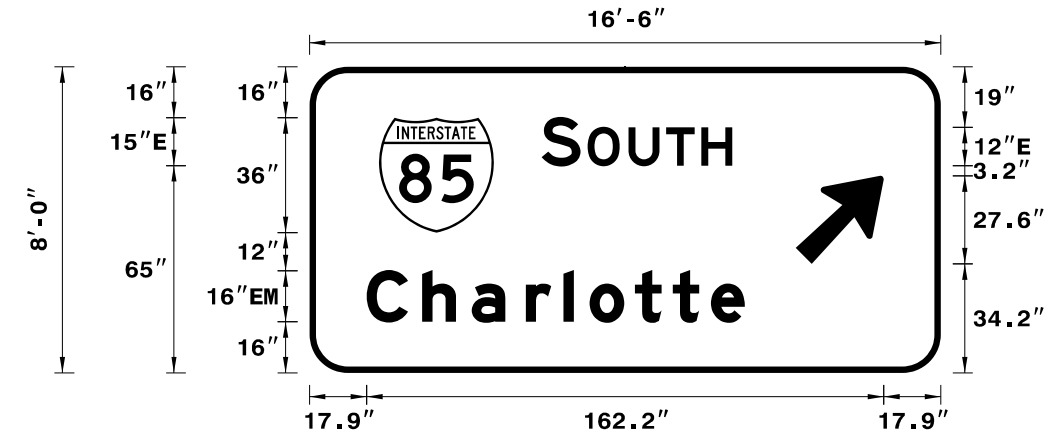

USE NOTES: 1,2,3
 1. Legend and border(except those that are colored black) shall be direct applied Grade A sheeting.
 2. Background shall be Grade C reflective sheeting.
 3. Shields: A, B, and C type arrows shall be on 0.032" (0.8mm) aluminum and demountable.

LETTER POSITIONS

Letter spacings are to start of next letter											Series/Size
S	O	U	T	H							Text Length
72.8	12.2	2.2	12.8	11.8	11	9.7	65.4				E 2000 59.8
17.9	17.4	15.5	17	11.8	8.2	14.2	11.8	12	10.6	61.5	EM 2000 118.6

FILENAME: U5806_SGN_DESIGN_PSH NORTH CAROLINA D.O.T. SIGN DETAIL

SIGN NUMBER: 8 TYPE: A QUANTITY: 1 SIGN WIDTH: 13'-0" HEIGHT: 9'-6" TOTAL AREA: 123.5 Sq.Ft. BORDER TYPE: FLUSH RECESS: 0" WIDTH: 2" RADII: 12" NO. Z BARS: 3 LENGTH: 148.0	BACKG COLOR: Green COPY COLOR: White SYMBOL X Y WID HT M1_1 22.6 61.2 36 36	DESIGN BY: K. BISBY PROJECT ID: U-5806 LOCATION: '250' EAST OF I-85 NB RAMPS CHECKED BY: D. SEARS MAY 08, 2017 DIV: 10
--	--	---

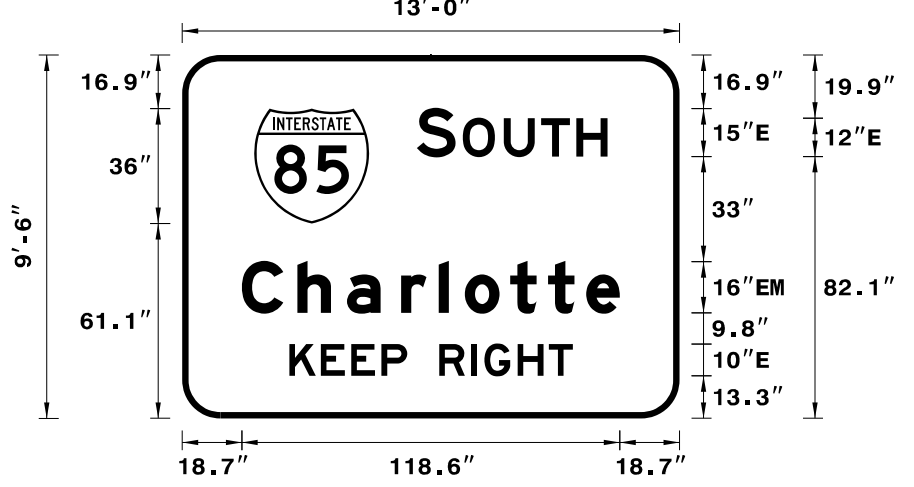

USE NOTES: 1,2,3
 1. Legend and border(except those that are colored black) shall be direct applied Grade A sheeting.
 2. Background shall be Grade C reflective sheeting.
 3. Shields: A, B, and C type arrows shall be on 0.032" (0.8mm) aluminum and demountable.

LETTER POSITIONS

Letter spacings are to start of next letter											Series/Size
S	O	U	T	H							Text Length
73.6	12.2	2.2	12.8	11.8	11	9.7	22.6				E 2000 59.8
18.7	17.4	15.5	17	11.8	8.2	14.2	11.8	12	10.6	18.7	EM 2000 118.6
	K	E	E	P	R	I	G	H	T		E 2000 88.9

FILENAME: U5806_SGN_DESIGN_PSH NORTH CAROLINA D.O.T. SIGN DETAIL

SIGN NUMBER: 9 TYPE: A QUANTITY: 1 SIGN WIDTH: 12'-6" HEIGHT: 11'-0" TOTAL AREA: 137.5 Sq.Ft. BORDER TYPE: FLUSH RECESS: 0" WIDTH: 2" RADII: 12" NO. Z BARS: 3 LENGTH: 142.0	BACKG COLOR: Green COPY COLOR: White SYMBOL X Y WID HT M1_1 19.5 80.4 36 36 AR_Type A 57.5 18.1 22.3 35	DESIGN BY: K. BISBY PROJECT ID: U-5806 LOCATION: BRUTON SMITH BLVD '250' EAST OF I-85 NB RAMPS CHECKED BY: D. SEARS MAY 03, 2017 DIV: 10
---	---	---

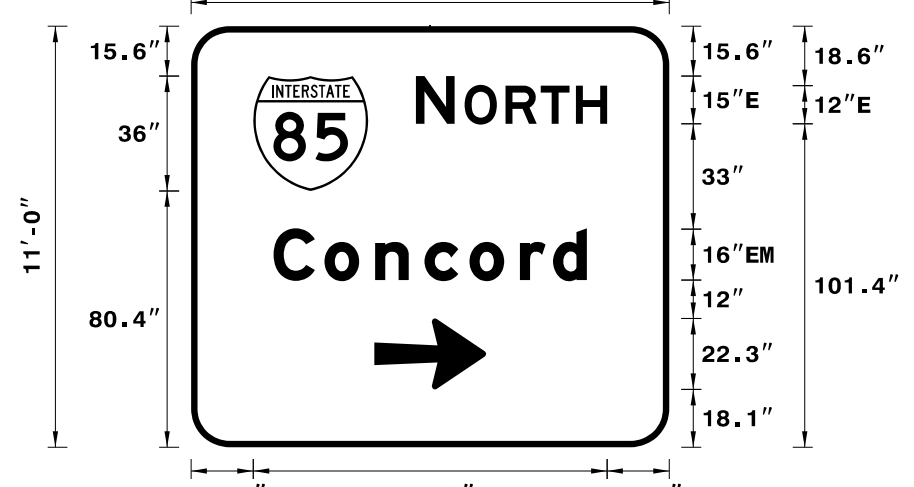

USE NOTES: 1,2,3
 1. Legend and border(except those that are colored black) shall be direct applied Grade A sheeting.
 2. Background shall be Grade C reflective sheeting.
 3. Shields: A, B, and C type arrows shall be on 0.032" (0.8mm) aluminum and demountable.

LETTER POSITIONS

Letter spacings are to start of next letter											Series/Size
N	O	R	T	H							Text Length
70.5	12.2	3.1	12.8	11	11	9.7	19.5				E 2000 59.9
25.9	16	15.8	15.5	14.1	15.8	10.4	10.6	25.9			EM 2000 98.2

FILENAME: U5806_SGN_DESIGN_PSH NORTH CAROLINA D.O.T. SIGN DETAIL

\$DATE\$
 \$FILE\$
 EJM

DOCUMENT NOT CONSIDERED FINAL
UNLESS ALL SIGNATURES COMPLETED

TIP NO. U-5806	SHEET NO. SIGN-4B
-------------------	----------------------

APPROVED: Kevin W. Bisby
 DATE: 9/5/2017

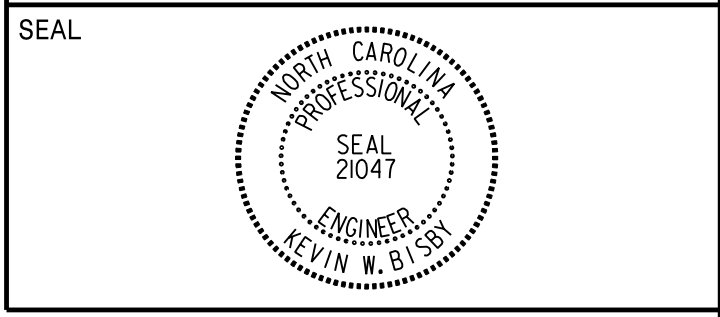

SIGN NUMBER: 10 TYPE: A QUANTITY: 1 SIGN WIDTH: 23'-0" HEIGHT: 7'-6" TOTAL AREA: 172.5 Sq. Ft. BORDER TYPE: FLUSH RECESS: 0" WIDTH: 2" RADII: 12" NO. Z BARS: 3 LENGTH: 268.0	BACKG COLOR: Green COPY COLOR: White <table border="1" style="width: 100%; border-collapse: collapse;"> <thead> <tr> <th>SYMBOL</th> <th>X</th> <th>Y</th> <th>WID</th> <th>HT</th> </tr> </thead> <tbody> <tr> <td>AR_Type C 90L</td> <td>50.1</td> <td>18</td> <td>25.9</td> <td>31.9</td> </tr> <tr> <td>AR_Type C 90L</td> <td>194.1</td> <td>18</td> <td>25.9</td> <td>31.9</td> </tr> </tbody> </table> MAT'L: 0.125" (3.2 mm) ALUMINUM	SYMBOL	X	Y	WID	HT	AR_Type C 90L	50.1	18	25.9	31.9	AR_Type C 90L	194.1	18	25.9	31.9	DESIGN BY: K. BISBY PROJECT ID: U-5806 LOCATION: I-85 SB EXIT RAMP CENTERED BETWEEN LOGO SIGNS CHECKED BY: D. SEARS DATE: Jun 07, 2017 DIV: 10	<p style="text-align: center;">Spacing Factor is 1 unless specified otherwise</p>																																															
SYMBOL	X	Y	WID	HT																																																													
AR_Type C 90L	50.1	18	25.9	31.9																																																													
AR_Type C 90L	194.1	18	25.9	31.9																																																													
USE NOTES: 1,2,3 1. Legend and border (except those that are colored black) shall be direct applied Grade A sheeting. 2. Background shall be Grade C reflective sheeting. 3. Shields: A, B, and C type arrows shall be on 0.032" (0.8mm) aluminum and demountable.																																																																	
<table border="1" style="width: 100%; border-collapse: collapse;"> <thead> <tr> <th colspan="12">Letter positions</th> <th>Series/Size</th> </tr> <tr> <th colspan="12">Letter spacings are to start of next letter</th> <th>Text Length</th> </tr> </thead> <tbody> <tr> <td>B</td><td>r</td><td>u</td><td>t</td><td>o</td><td>n</td><td>S</td><td>m</td><td>i</td><td>t</td><td>h</td><td>B</td><td>l</td><td>v</td><td>d</td><td>EM 2000</td> </tr> <tr> <td>17.8</td><td>17.4</td><td>11.8</td><td>15.4</td><td>12</td><td>15.8</td><td>10.6</td><td>16</td><td>17.9</td><td>24</td><td>8</td><td>13.4</td><td>10.6</td><td>18</td><td>17.4</td><td>7.8</td><td>15.5</td><td>10.6</td><td>17.8</td><td>240.3</td> </tr> </tbody> </table>				Letter positions												Series/Size	Letter spacings are to start of next letter												Text Length	B	r	u	t	o	n	S	m	i	t	h	B	l	v	d	EM 2000	17.8	17.4	11.8	15.4	12	15.8	10.6	16	17.9	24	8	13.4	10.6	18	17.4	7.8	15.5	10.6	17.8	240.3
Letter positions												Series/Size																																																					
Letter spacings are to start of next letter												Text Length																																																					
B	r	u	t	o	n	S	m	i	t	h	B	l	v	d	EM 2000																																																		
17.8	17.4	11.8	15.4	12	15.8	10.6	16	17.9	24	8	13.4	10.6	18	17.4	7.8	15.5	10.6	17.8	240.3																																														
FILENAME: U5806_SGN_DESIGNS NORTH CAROLINA D.O.T. SIGN DETAIL																																																																	

SIGN NUMBER: 11 TYPE: A QUANTITY: 1 SIGN WIDTH: 23'-0" HEIGHT: 9'-6" TOTAL AREA: 218.5 Sq. Ft. BORDER TYPE: FLUSH RECESS: 0" WIDTH: 2" RADII: 12" NO. Z BARS: 3 LENGTH: 268.0	BACKG COLOR: Green COPY COLOR: White <table border="1" style="width: 100%; border-collapse: collapse;"> <thead> <tr> <th>SYMBOL</th> <th>X</th> <th>Y</th> <th>WID</th> <th>HT</th> </tr> </thead> <tbody> <tr> <td>AR_Type C 90R</td> <td>50.1</td> <td>10.6</td> <td>25.9</td> <td>31.9</td> </tr> <tr> <td>AR_Type C 90R</td> <td>194.1</td> <td>10.6</td> <td>25.9</td> <td>31.9</td> </tr> </tbody> </table> MAT'L: 0.125" (3.2 mm) ALUMINUM	SYMBOL	X	Y	WID	HT	AR_Type C 90R	50.1	10.6	25.9	31.9	AR_Type C 90R	194.1	10.6	25.9	31.9	DESIGN BY: K. BISBY PROJECT ID: U-5806 LOCATION: I-85 SB EXIT RAMP CENTERED BETWEEN LOGO SIGNS CHECKED BY: D. SEARS DATE: Jun 07, 2017 DIV: 10	<p style="text-align: center;">Spacing Factor is 1 unless specified otherwise</p>																																																																																																																																									
SYMBOL	X	Y	WID	HT																																																																																																																																																							
AR_Type C 90R	50.1	10.6	25.9	31.9																																																																																																																																																							
AR_Type C 90R	194.1	10.6	25.9	31.9																																																																																																																																																							
USE NOTES: 1,2,3 1. Legend and border (except those that are colored black) shall be direct applied Grade A sheeting. 2. Background shall be Grade C reflective sheeting. 3. Shields: A, B, and C type arrows shall be on 0.032" (0.8mm) aluminum and demountable.																																																																																																																																																											
<table border="1" style="width: 100%; border-collapse: collapse;"> <thead> <tr> <th colspan="12">Letter positions</th> <th>Series/Size</th> </tr> <tr> <th colspan="12">Letter spacings are to start of next letter</th> <th>Text Length</th> </tr> </thead> <tbody> <tr> <td>C</td><td>o</td><td>n</td><td>c</td><td>o</td><td>r</td><td>d</td><td>M</td><td>i</td><td>l</td><td>l</td><td>s</td><td>B</td><td>l</td><td>v</td><td>d</td><td>EM 2000</td> </tr> <tr> <td>16.2</td><td>16</td><td>15.8</td><td>15.5</td><td>14.1</td><td>15.8</td><td>10.4</td><td>10.6</td><td>16</td><td>20.3</td><td>9.6</td><td>9.6</td><td>7.8</td><td>10.6</td><td>16</td><td>17.4</td><td>7.8</td><td>15.5</td><td>10.6</td><td>18.2</td><td>239.5</td> </tr> <tr> <td>M</td><td>A</td><td>L</td><td>L</td><td></td><td></td><td></td><td></td><td></td><td></td><td></td><td></td><td></td><td></td><td></td><td></td><td></td><td></td><td></td><td></td><td></td><td>E 2000</td> </tr> <tr> <td>46.2</td><td>11.1</td><td>11.9</td><td>9.2</td><td>7.5</td><td>190.2</td><td></td><td></td><td></td><td></td><td></td><td></td><td></td><td></td><td></td><td></td><td></td><td></td><td></td><td></td><td></td><td>39.7</td> </tr> <tr> <td>T</td><td>R</td><td>A</td><td>F</td><td>F</td><td>I</td><td>C</td><td></td><td></td><td></td><td></td><td></td><td></td><td></td><td></td><td></td><td></td><td></td><td></td><td></td><td></td><td>E 2000</td> </tr> <tr> <td>35.6</td><td>9.2</td><td>9.2</td><td>11.9</td><td>9.2</td><td>9.2</td><td>4.1</td><td>8.1</td><td>179.6</td><td></td><td></td><td></td><td></td><td></td><td></td><td></td><td></td><td></td><td></td><td></td><td></td><td>60.9</td> </tr> </tbody> </table>				Letter positions												Series/Size	Letter spacings are to start of next letter												Text Length	C	o	n	c	o	r	d	M	i	l	l	s	B	l	v	d	EM 2000	16.2	16	15.8	15.5	14.1	15.8	10.4	10.6	16	20.3	9.6	9.6	7.8	10.6	16	17.4	7.8	15.5	10.6	18.2	239.5	M	A	L	L																		E 2000	46.2	11.1	11.9	9.2	7.5	190.2																39.7	T	R	A	F	F	I	C															E 2000	35.6	9.2	9.2	11.9	9.2	9.2	4.1	8.1	179.6													60.9
Letter positions												Series/Size																																																																																																																																															
Letter spacings are to start of next letter												Text Length																																																																																																																																															
C	o	n	c	o	r	d	M	i	l	l	s	B	l	v	d	EM 2000																																																																																																																																											
16.2	16	15.8	15.5	14.1	15.8	10.4	10.6	16	20.3	9.6	9.6	7.8	10.6	16	17.4	7.8	15.5	10.6	18.2	239.5																																																																																																																																							
M	A	L	L																		E 2000																																																																																																																																						
46.2	11.1	11.9	9.2	7.5	190.2																39.7																																																																																																																																						
T	R	A	F	F	I	C															E 2000																																																																																																																																						
35.6	9.2	9.2	11.9	9.2	9.2	4.1	8.1	179.6													60.9																																																																																																																																						
FILENAME: U5806_SGN_DESIGNS NORTH CAROLINA D.O.T. SIGN DETAIL																																																																																																																																																											

09/05/2017
 U5806_SGN_DESIGNS_PSH.dgn
 EJM

PLANS PREPARED BY :

RUMMEL, KLEPPER & KAHL, LLP
 900 RIDGEFIELD DRIVE SUITE 350
 RALEIGH, NORTH CAROLINA 27609-3960
 NC LICENSE NO. F-0112 (919) 878-9560

SIGN DESIGNS

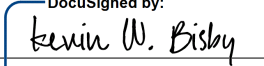
APPROVED: 
 DATE: 9/5/2017

SEAL



SIGN NUMBER: 201 TYPE: A QUANTITY: 1 SIGN WIDTH: 6'-0" HEIGHT: 5'-0" TOTAL AREA: 30.0 Sq.Ft. BORDER TYPE: FLUSH RECESS: 0" WIDTH: 1.5" RADII: 6" NO. Z BARS: 2 LENGTH: 64.0	BACKG COLOR: Green COPY COLOR: White <table border="1" style="width: 100%; border-collapse: collapse;"> <tr> <th>SYMBOL</th> <th>X</th> <th>Y</th> <th>WID</th> <th>HT</th> </tr> <tr> <td>AR_Type A</td> <td>24.5</td> <td>6</td> <td>18.3</td> <td>29.3</td> </tr> </table> MAT'L: 0.125" (3.2 mm) ALUMINUM	SYMBOL	X	Y	WID	HT	AR_Type A	24.5	6	18.3	29.3	DESIGN BY: K. BISBY PROJECT ID: U-5806 CHECKED BY: D. SEARS LOCATION: BRUTON SMITH BLVD INSIDE GRASS GORE OF I-85 SB ENTRANCE LOOP May 03, 2017 DIV: 10
SYMBOL	X	Y	WID	HT								
AR_Type A	24.5	6	18.3	29.3								

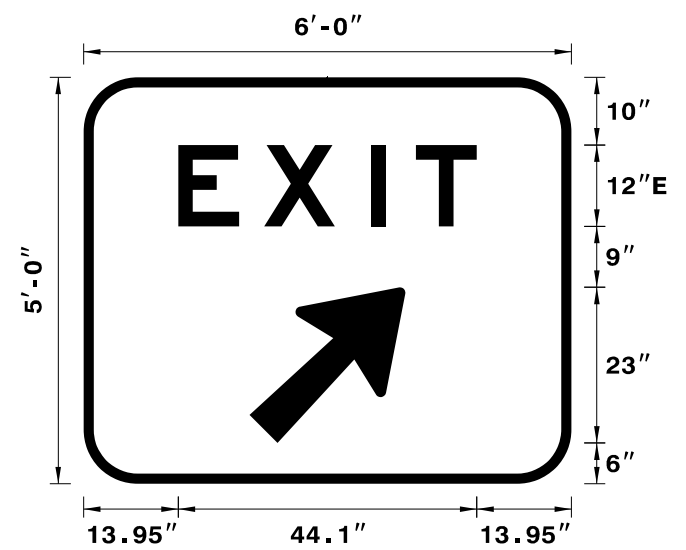

Spacing Factor is 2.25 for "EXIT"
Spacing Factor is 1 unless specified otherwise

USE NOTES: 1, 2

- Legend and border(except those that are colored black) shall be direct applied Grade C sheeting.
- Background shall be Grade C reflective sheeting.
- Shields: A, B, and C type arrows shall be on 0.032" (0.8mm) aluminum and demountable.

LETTER POSITIONS

Letter spacings are to start of next letter

	E	X	I	T		Series/Size Text Length	
	14	12.7	15.7	6.7	9	14	E 2000 44.1

NORTH CAROLINA D.O.T. SIGN DETAIL

SIGN NUMBER: 410 TYPE: E QUANTITY: 1 SIGN WIDTH: 2'-6" HEIGHT: 1'-3" TOTAL AREA: 3.1 Sq.Ft. BORDER TYPE: RECESS RECESS: 0.38" WIDTH: 0.38" RADII: 1.5" NO. Z BARS: LENGTH:	BACKG COLOR: Yellow COPY COLOR: Black <table border="1" style="width: 100%; border-collapse: collapse;"> <tr> <th>SYMBOL</th> <th>X</th> <th>Y</th> <th>WID</th> <th>HT</th> </tr> </table> MAT'L: 0.125" (3.2 mm) ALUMINUM	SYMBOL	X	Y	WID	HT	DESIGN BY: D. SEARS PROJECT ID: U-5806 CHECKED BY: K. BISBY LOCATION: -L- STA 14+36 Jun 14, 2017 DIV: 10
SYMBOL	X	Y	WID	HT			

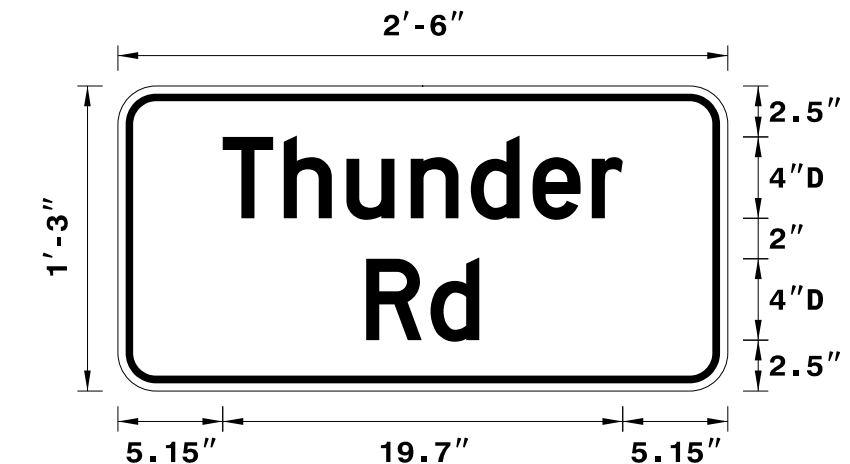

Spacing Factor is 1 unless specified otherwise

USE NOTES: 1, 2

- Legend and border(except those that are colored black) shall be direct applied Grade C sheeting.
- Background shall be Grade C reflective sheeting.
- Shields: A, B, and C type arrows shall be on 0.032" (0.8mm) aluminum and demountable.

LETTER POSITIONS

Letter spacings are to start of next letter

	T	h	u	n	d	e	r		Series/Size Text Length	
	5.2	3	3.1	3.2	3	3	2.9	1.5	5.2	D 2000 19.7
	12.2	3.2	2.4	12.2						D 2000 5.6

NORTH CAROLINA D.O.T. SIGN DETAIL

SIGN NUMBER: 411 TYPE: E QUANTITY: 1 SIGN WIDTH: 2'-6" HEIGHT: 2'-6" TOTAL AREA: 6.3 Sq.Ft. BORDER TYPE: FLUSH RECESS: 0.5" WIDTH: 0.75" RADII: 1.88" NO. Z BARS: LENGTH:	BACKG COLOR: White COPY COLOR: Black <table border="1" style="width: 100%; border-collapse: collapse;"> <tr> <th>SYMBOL</th> <th>X</th> <th>Y</th> <th>WID</th> <th>HT</th> </tr> <tr> <td>AR_THRU</td> <td>4.8</td> <td>7.3</td> <td>6.5</td> <td>20.4</td> </tr> <tr> <td>AR_THRU_RT</td> <td>15.2</td> <td>7.3</td> <td>13.3</td> <td>20.4</td> </tr> </table> MAT'L: 0.125" (3.2 mm) ALUMINUM	SYMBOL	X	Y	WID	HT	AR_THRU	4.8	7.3	6.5	20.4	AR_THRU_RT	15.2	7.3	13.3	20.4	DESIGN BY: D. SEARS PROJECT ID: U-5806 CHECKED BY: K. BISBY LOCATION: -DRW06- STA 25+85 Sep 05, 2017 DIV: 10
SYMBOL	X	Y	WID	HT													
AR_THRU	4.8	7.3	6.5	20.4													
AR_THRU_RT	15.2	7.3	13.3	20.4													

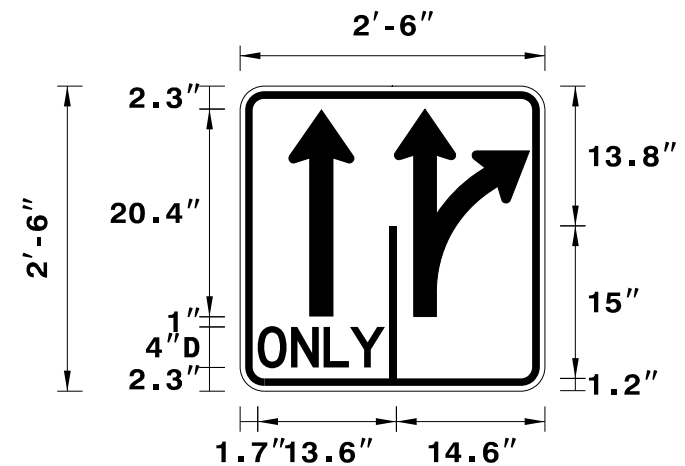

Spacing Factor is 0.5 for "ONLY"

USE NOTES: 1, 2

- Legend and border(except those that are colored black) shall be direct applied Grade C sheeting.
- Background shall be Grade C reflective sheeting.
- Shields: A, B, and C type arrows shall be on 0.032" (0.8mm) aluminum and demountable.

LETTER POSITIONS

Letter spacings are to start of next letter

	O	N	L	Y		Series/Size Text Length	
	1.7	3.3	3.2	2.6	3.4	15.7	D 2000 12.5

NORTH CAROLINA D.O.T. SIGN DETAIL

PLANS PREPARED BY :



RUMMEL, KLEPPER & KAHL, LLP
 900 RIDGEFIELD DRIVE SUITE 350
 RALEIGH, NORTH CAROLINA 27609-3960
 NC LICENSE NO. F-0112 (919) 878-9560

SIGN DESIGNS

NOTES:

- IF THE CONTRACTOR PROVIDES AN ALUMINUM SIGN STRUCTURE, EACH SHALL BE PROVIDED WITH AN APPROVED HIGHWAY TRUSS DAMPER DEVICE IN ACCORDANCE WITH AASHTO SPECIFICATIONS.
- FIELD VERIFICATION SHALL BE REQUIRED FOR ALL FOOTING ELEVATIONS, PER LATEST NCDOT STANDARD SPECIFICATIONS FOR ROADS AND STRUCTURES.
- THE TOP OF THE FOOTING SHALL EXTEND AT LEAST 4" AND NOT MORE THAN 24" ABOVE THE HIGHEST POINT OF THE GROUND SURFACE AT THE FOOTING.
- SIGN HANGERS AND ATTACHMENT HARDWARE SHALL BE PROVIDED AND INSTALLED ON THE ASSEMBLY TO ACCOMMODATE ALL SIGNS SHOWN IN THE PLANS.
- DESIGN AND CONSTRUCTION REQUIREMENTS FOR SIGN STRUCTURES SHALL ACCOMMODATE WIND VELOCITY OF 90 MPH.
- MOUNT SIGNS VERTICALLY CENTERED ON HORIZONTAL MEMBER OF STRUCTURE.
- SIGN DIMENSIONS SHOWN SHALL BE USED FOR WIND LOAD AND DEAD LOAD COMPUTATIONS IN DESIGN OF STRUCTURE AND FOOTINGS.

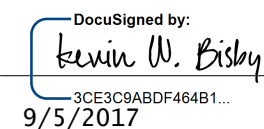
APPROVED: 
DocuSigned by:
Kevin W. Bisby
3CE3E8ADDF484B1
9/5/2017

DATE: 9/5/2017

SEAL

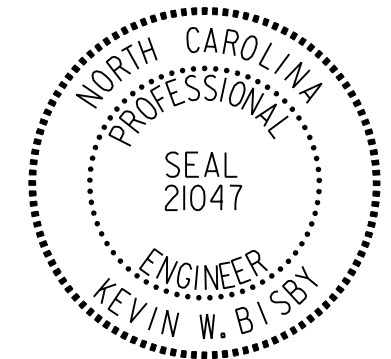
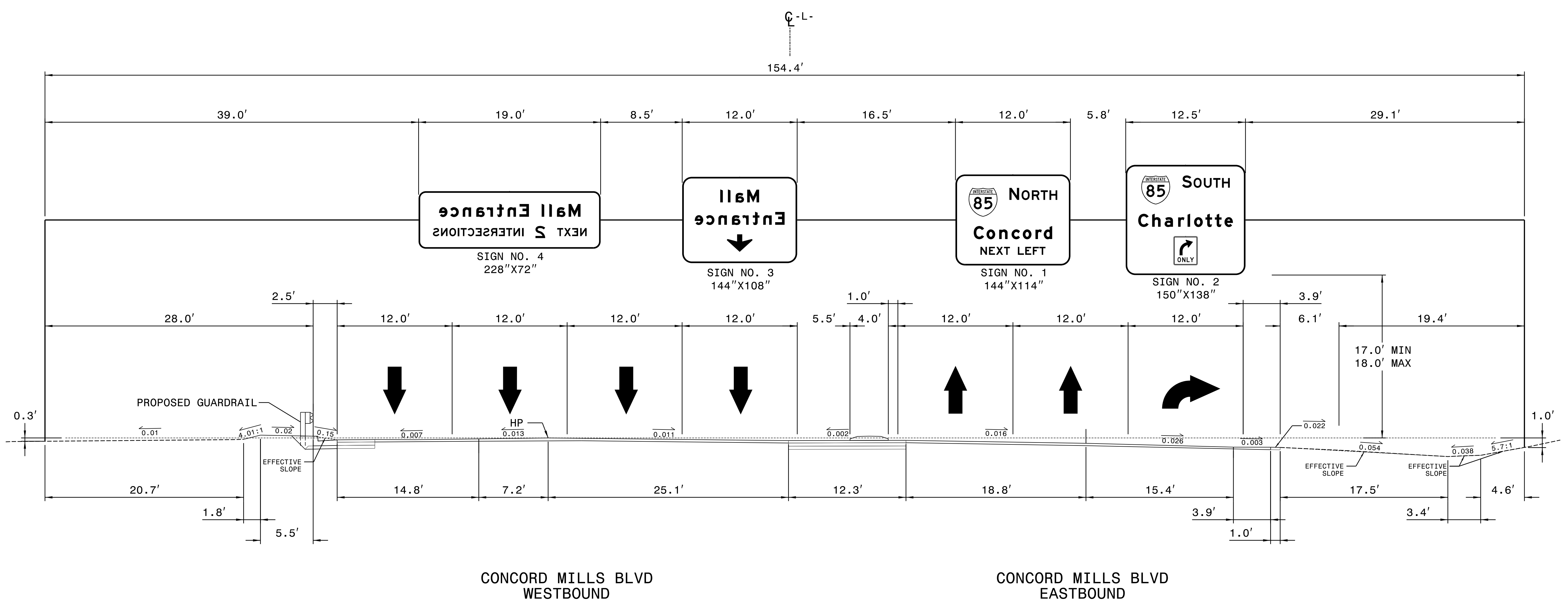
9/5/2017 U5806-SGN-SLDA.dgn

PLANS PREPARED BY :



RUMMEL, KLEPPER & KAHL, LLP
 900 RIDGEFIELD DRIVE SUITE 350
 RALEIGH, NORTH CAROLINA 27609-3960
 NC LICENSE NO. F-0112 • (919) 878-9560

OVERHEAD SIGN ASSEMBLY "A"
-L- STA 34+94

NOTES:

1. IF THE CONTRACTOR PROVIDES AN ALUMINUM SIGN STRUCTURE, EACH SHALL BE PROVIDED WITH AN APPROVED HIGHWAY TRUSS DAMPER DEVICE IN ACCORDANCE WITH AASHTO SPECIFICATIONS.
2. FIELD VERIFICATION SHALL BE REQUIRED FOR ALL FOOTING ELEVATIONS, PER LATEST NCDOT STANDARD SPECIFICATIONS FOR ROADS AND STRUCTURES.
3. THE TOP OF THE FOOTING SHALL EXTEND AT LEAST 4" AND NOT MORE THAN 24" ABOVE THE HIGHEST POINT OF THE GROUND SURFACE AT THE FOOTING.
4. SIGN HANGERS AND ATTACHMENT HARDWARE SHALL BE PROVIDED AND INSTALLED ON THE ASSEMBLY TO ACCOMMODATE ALL SIGNS SHOWN IN THE PLANS.
5. DESIGN AND CONSTRUCTION REQUIREMENTS FOR SIGN STRUCTURES SHALL ACCOMMODATE WIND VELOCITY OF 90 MPH.
6. MOUNT SIGNS VERTICALLY CENTERED ON HORIZONTAL MEMBER OF STRUCTURE.
7. SIGN DIMENSIONS SHOWN SHALL BE USED FOR WIND LOAD AND DEAD LOAD COMPUTATIONS IN DESIGN OF STRUCTURE AND FOOTINGS.

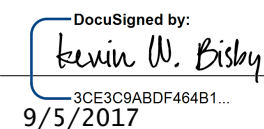
APPROVED: 
DocuSigned by:
Kevin W. Bisby
3CE3E8A8DF484B1
9/5/2017

DATE: 9/5/2017

SEAL

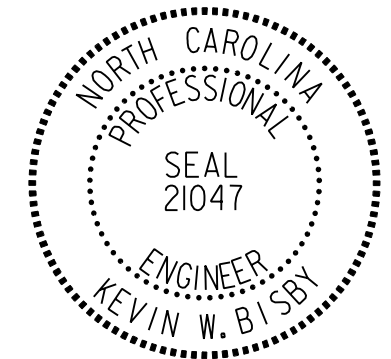
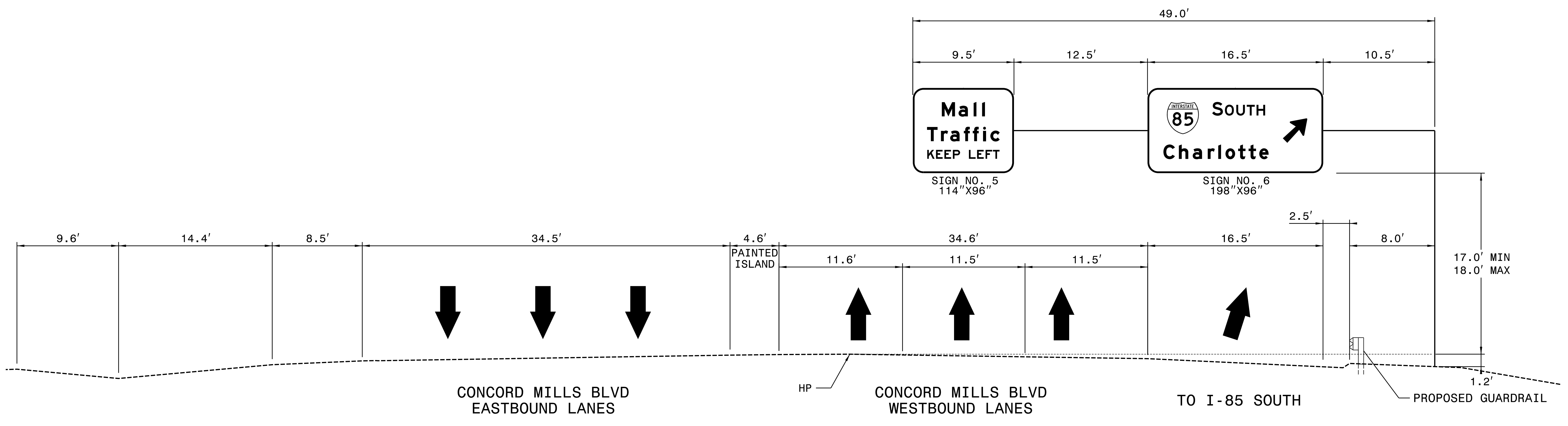
PLANS PREPARED BY :



RUMMEL, KLEPPER & KAHL, LLP
 900 RIDGEFIELD DRIVE SUITE 350
 RALEIGH, NORTH CAROLINA 27609-3960
 NC LICENSE NO. F-0112 • (919) 878-9560

**OVERHEAD SIGN ASSEMBLY "B"
 OFFSITE
 WB CONCORD MILLS BLVD
 AT I-85 SB LOOP GORE**

9/5/2017
 U5806-SGN-SLDB.dgn
 keus

NOTES:

1. IF THE CONTRACTOR PROVIDES AN ALUMINUM SIGN STRUCTURE, EACH SHALL BE PROVIDED WITH AN APPROVED HIGHWAY TRUSS DAMPER DEVICE IN ACCORDANCE WITH AASHTO SPECIFICATIONS.
2. FIELD VERIFICATION SHALL BE REQUIRED FOR ALL FOOTING ELEVATIONS, PER LATEST NCDOT STANDARD SPECIFICATIONS FOR ROADS AND STRUCTURES.
3. THE TOP OF THE FOOTING SHALL EXTEND AT LEAST 4" AND NOT MORE THAN 24" ABOVE THE HIGHEST POINT OF THE GROUND SURFACE AT THE FOOTING.
4. SIGN HANGERS AND ATTACHMENT HARDWARE SHALL BE PROVIDED AND INSTALLED ON THE ASSEMBLY TO ACCOMMODATE ALL SIGNS SHOWN IN THE PLANS.
5. DESIGN AND CONSTRUCTION REQUIREMENTS FOR SIGN STRUCTURES SHALL ACCOMMODATE WIND VELOCITY OF 90 MPH.
6. MOUNT SIGNS VERTICALLY CENTERED ON HORIZONTAL MEMBER OF STRUCTURE.
7. SIGN DIMENSIONS SHOWN SHALL BE USED FOR WIND LOAD AND DEAD LOAD COMPUTATIONS IN DESIGN OF STRUCTURE AND FOOTINGS.

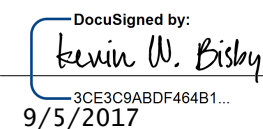
APPROVED: 
DocuSigned by:
Kevin W. Bisby
3CE3E8A8DF484B1
9/5/2017

DATE: 9/5/2017

SEAL

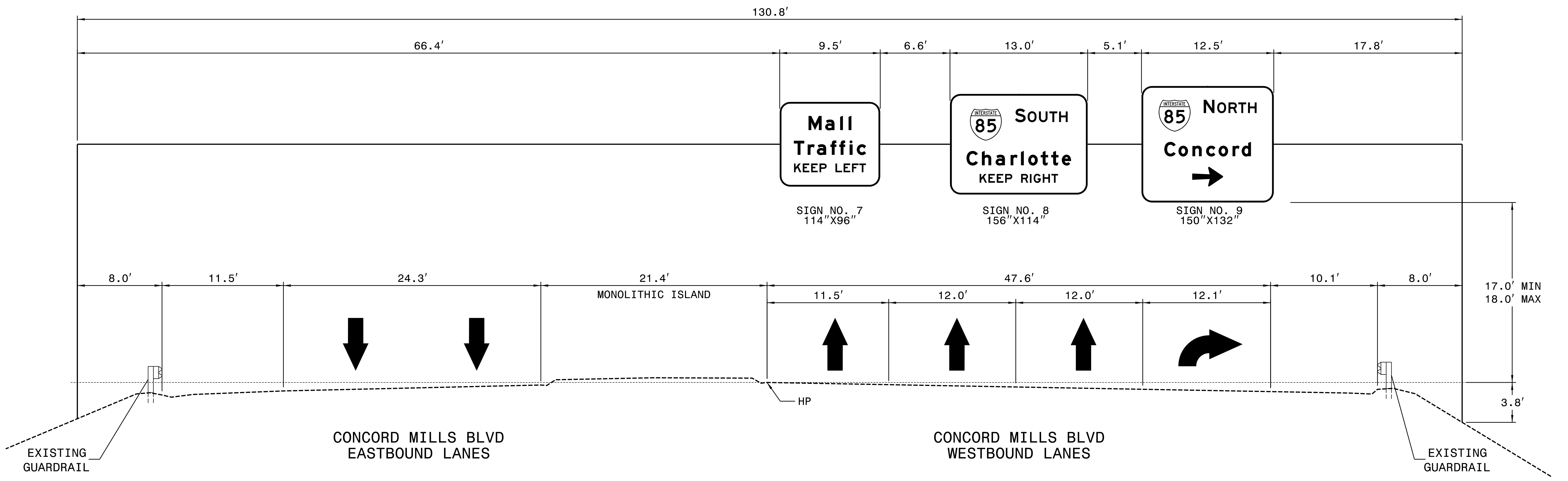
9/5/2017
U5806-SGN-SLDC.dgn
Klaus

PLANS PREPARED BY :



RUMMEL, KLEPPER & KAHL, LLP
 900 RIDGEFIELD DRIVE SUITE 350
 RALEIGH, NORTH CAROLINA 27609-3960
 NC LICENSE NO. F-0112 • (919) 878-9560

**OVERHEAD SIGN ASSEMBLY "C"
 OFFSITE
 WB BRUTON SMITH BLVD ~250' EAST OF
 I-85 NB RAMPS**

NOTES:

1. IF THE CONTRACTOR PROVIDES AN ALUMINUM SIGN STRUCTURE, EACH SHALL BE PROVIDED WITH AN APPROVED HIGHWAY TRUSS DAMPER DEVICE IN ACCORDANCE WITH AASHTO SPECIFICATIONS.
2. FIELD VERIFICATION SHALL BE REQUIRED FOR ALL FOOTING ELEVATIONS, PER LATEST NCDOT STANDARD SPECIFICATIONS FOR ROADS AND STRUCTURES.
3. THE TOP OF THE FOOTING SHALL EXTEND AT LEAST 4" AND NOT MORE THAN 24" ABOVE THE HIGHEST POINT OF THE GROUND SURFACE AT THE FOOTING.
4. SIGN HANGERS AND ATTACHMENT HARDWARE SHALL BE PROVIDED AND INSTALLED ON THE ASSEMBLY TO ACCOMMODATE ALL SIGNS SHOWN IN THE PLANS.
5. DESIGN AND CONSTRUCTION REQUIREMENTS FOR SIGN STRUCTURES SHALL ACCOMMODATE WIND VELOCITY OF 90 MPH.
6. MOUNT SIGNS VERTICALLY CENTERED ON HORIZONTAL MEMBER OF STRUCTURE.
7. SIGN DIMENSIONS SHOWN SHALL BE USED FOR WIND LOAD AND DEAD LOAD COMPUTATIONS IN DESIGN OF STRUCTURE AND FOOTINGS.

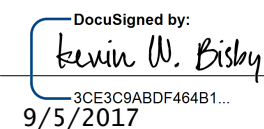
APPROVED: 
DocuSigned by:
Kevin W. Bisby
3CE3E9A8DF484B1
9/5/2017

DATE: 9/5/2017

SEAL

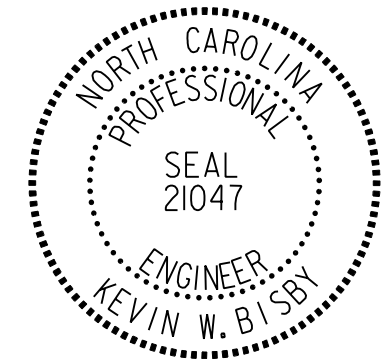
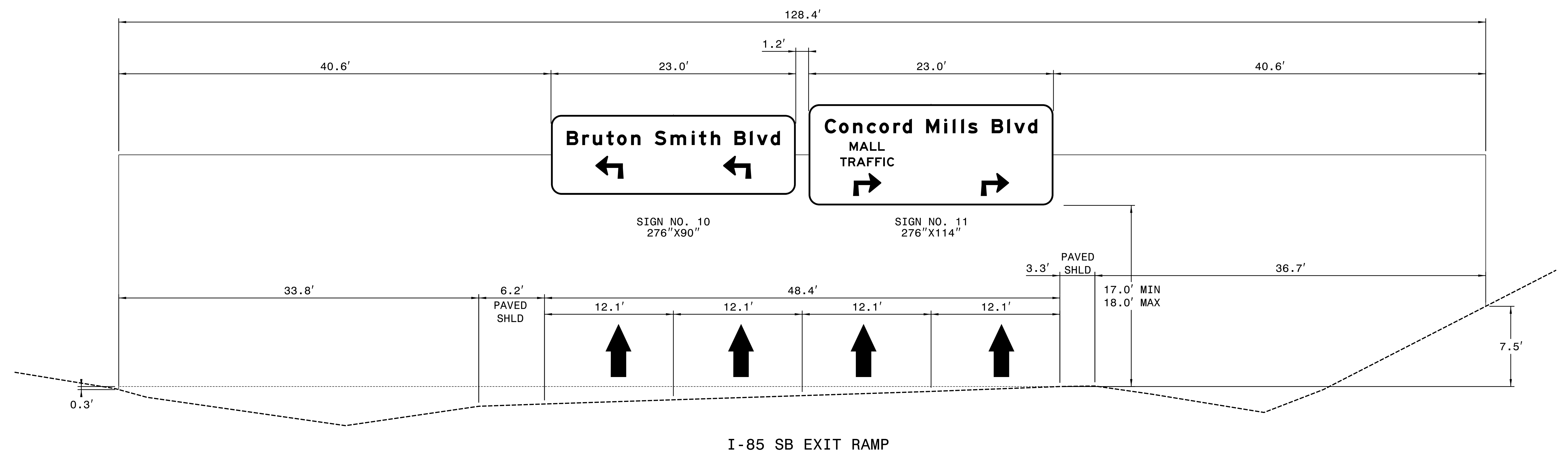
9/5/2017
U5806-SGN-SLDD.dgn
keus

PLANS PREPARED BY :



RUMMEL, KLEPPER & KAHL, LLP
 900 RIDGEFIELD DRIVE SUITE 350
 RALEIGH, NORTH CAROLINA 27609-3960
 NC LICENSE NO. F-0112 • (919) 878-9560

**OVERHEAD SIGN ASSEMBLY "D"
 OFFSITE
 I-85 SB EXIT RAMP
 CENTERED BETWEEN LOGO SIGNS**

APPROVED: *Kevin W. Bisby*
DocuSigned by:
 Kevin W. Bisby
 3CE368BDF484B1
 9/5/2017

DATE: _____

SEAL

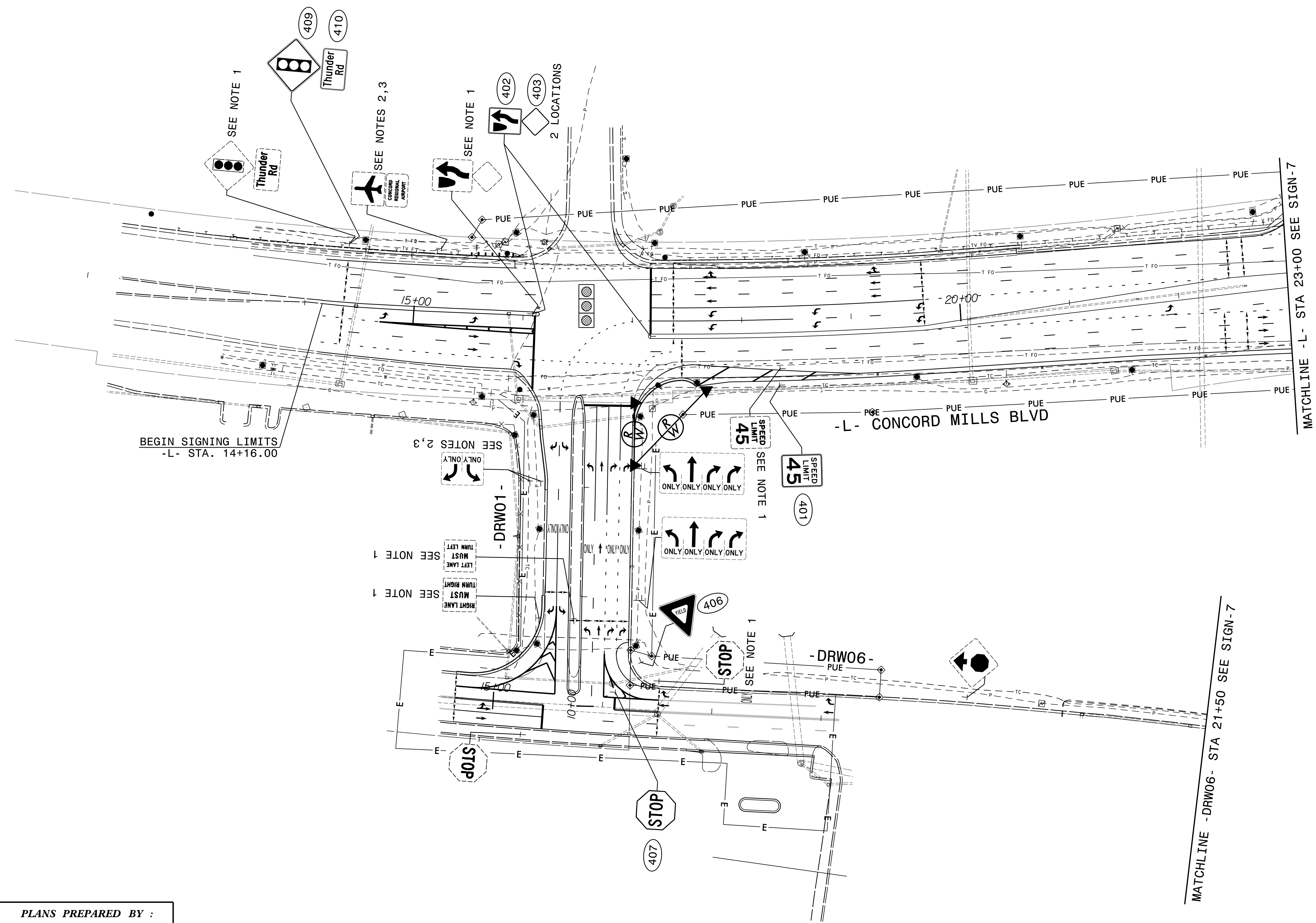

BEGIN SIGNING LIMITS
-L- STA. 14+16.00

MATCHLINE - DRW06 - STA 21+50 SEE SIGN-7

MATCHLINE - L - STA 23+00 SEE SIGN-7

PLANS PREPARED BY :
RK&K
 RUMMEL, KLEPPER & KAHL, LLP
 900 RIDGEFIELD DRIVE SUITE 350
 RALEIGH, NORTH CAROLINA 27609-3960
 NC LICENSE NO. F-0112 • (919) 878-9560

EXISTING & PROPOSED SIGNS
 -L- STA 10+00 TO STA 23+00,
 -DRW01-, -DRW06-

9/5/2017
 U5806-SGN-PSH-06.dgn
 K.ewis

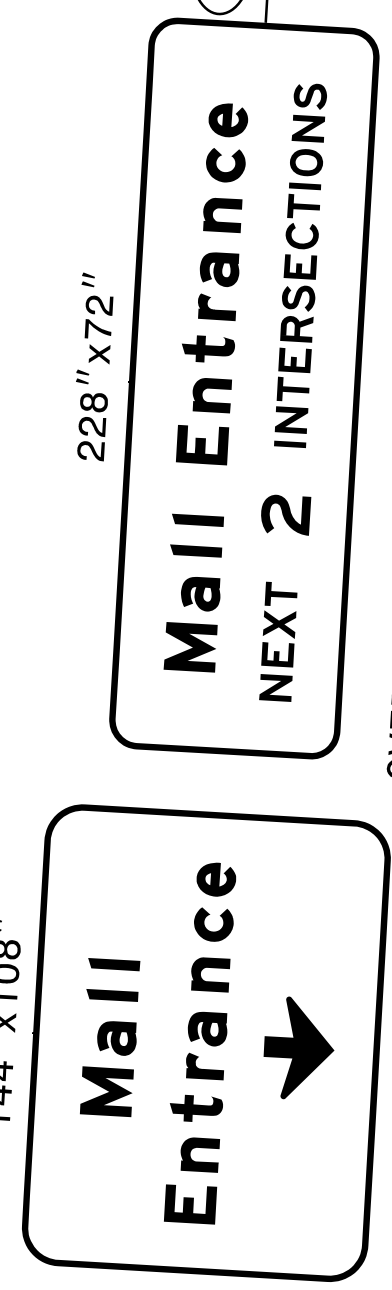
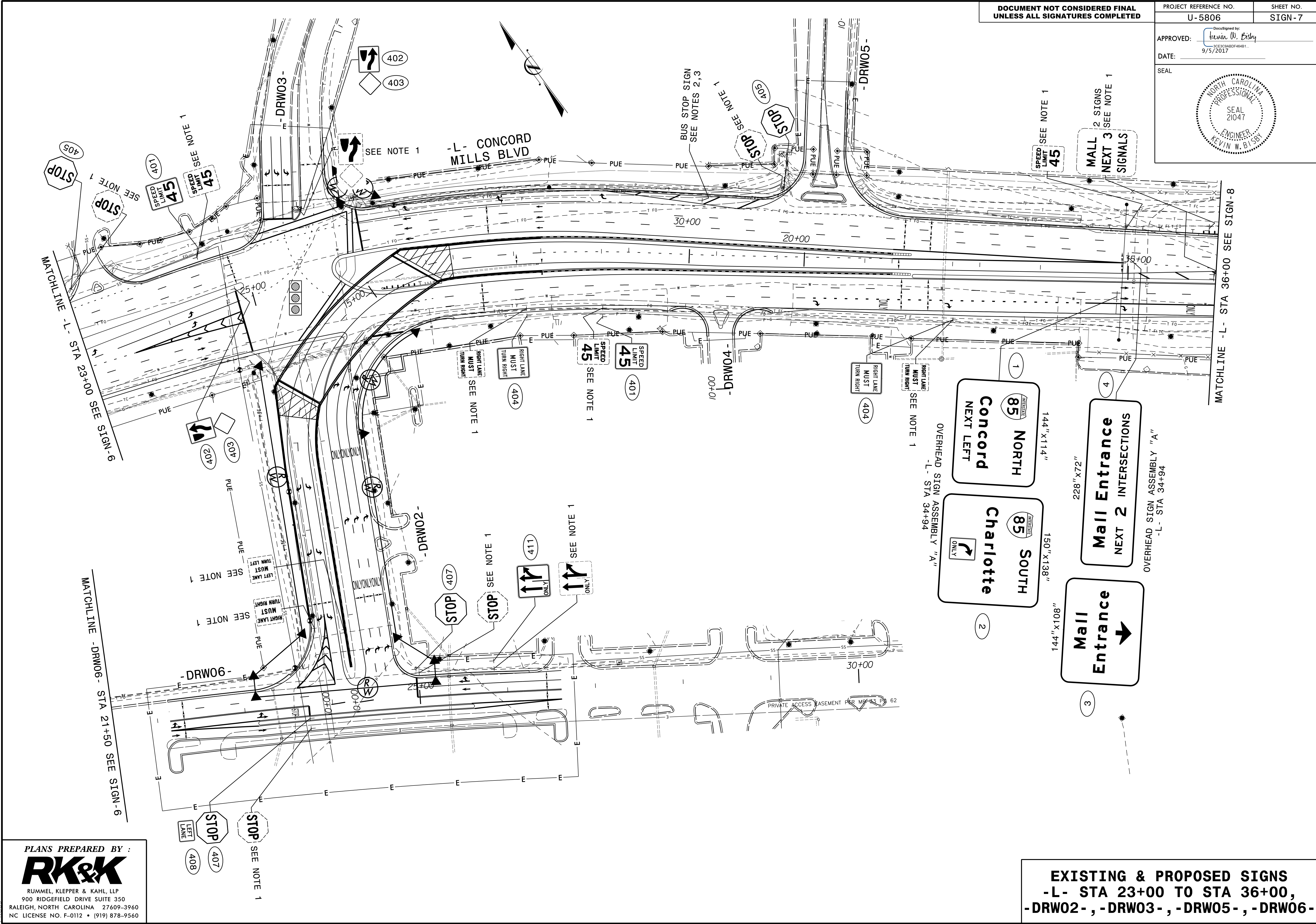

EXISTING & PROPOSED SIGNS
-L- STA 23+00 TO STA 36+00,
-DRW02-, -DRW03-, -DRW05-, -DRW06-

PLANS PREPARED BY :
RK&K
RUMMEL, KLEPPER & KAHL, LLP
900 RIDGEFIELD DRIVE SUITE 350
RALEIGH, NORTH CAROLINA 27609-3960
NC LICENSE NO. F-0112 • (919) 878-9560

9/5/2017
U5806-SGN-PSH-07.dgn
Kens

DOCUMENT NOT CONSIDERED FINAL UNLESS ALL SIGNATURES COMPLETED	PROJECT REFERENCE NO. U-5806	SHEET NO. SIGN-8
	APPROVED: <i>Kevin W. Bisby</i> 9/5/2017	
DATE: _____		
SEAL		
		

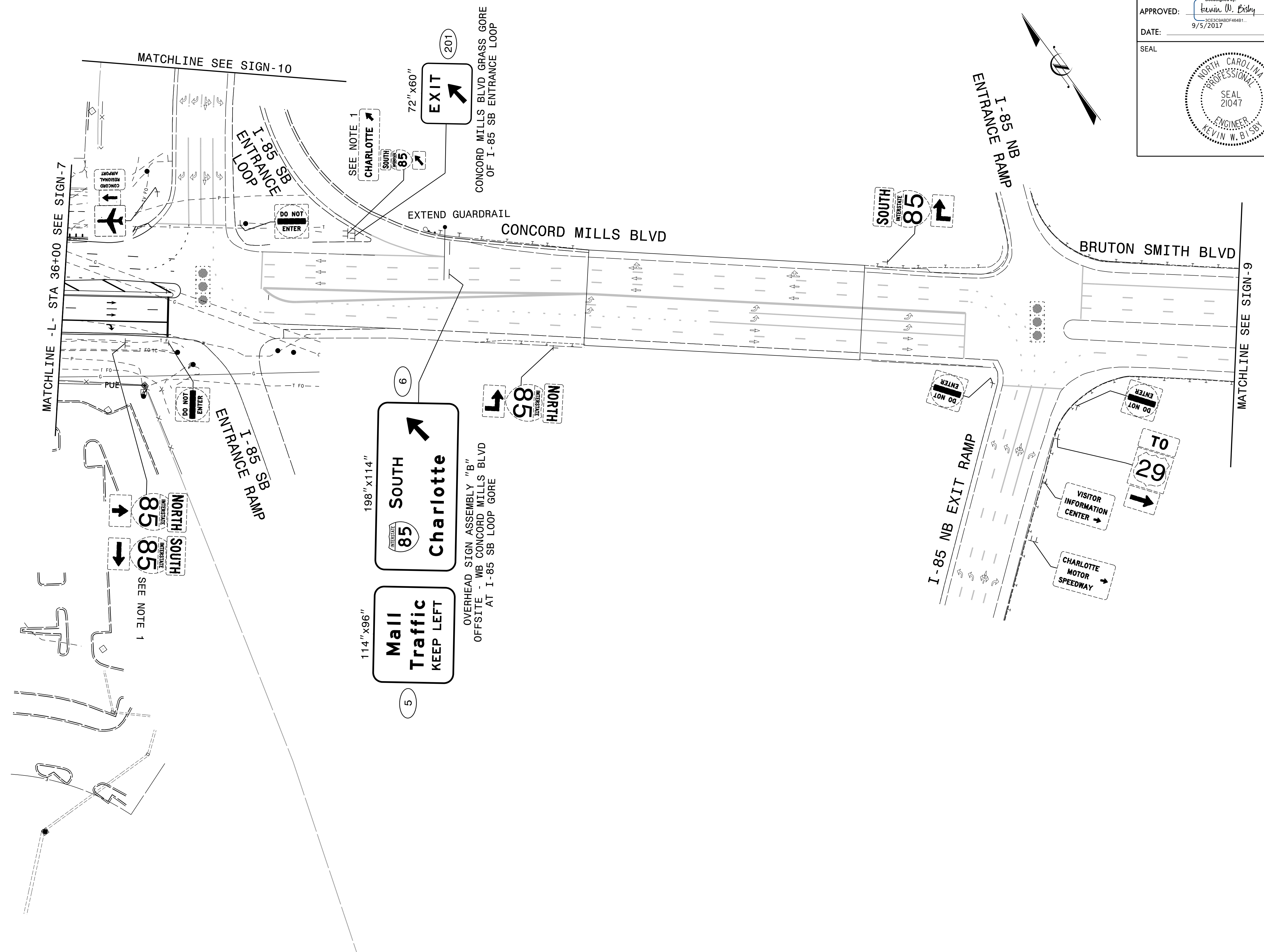

9/5/2017
U5806-SGN_PSH-08.dgn
RK&K

PLANS PREPARED BY :

 RUMMEL, KLEPPER & KAHL, LLP
 900 RIDGEFIELD DRIVE SUITE 350
 RALEIGH, NORTH CAROLINA 27609-3960
 NC LICENSE NO. F-0112 • (919) 878-9560

**EXISTING & PROPOSED SIGNS
 -L- STA 36+00 TO
 EAST OF I-85 NB RAMPS**

**DOCUMENT NOT CONSIDERED FINAL
UNLESS ALL SIGNATURES COMPLETED**

PROJECT REFERENCE NO. U-5806	SHEET NO. SIGN-9
---------------------------------	---------------------

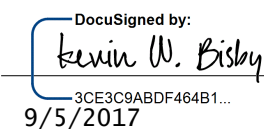
APPROVED: 
DocuSigned by:
Kevin W. Bisby
3CE368BDF464B1
9/5/2017

DATE: _____

SEAL

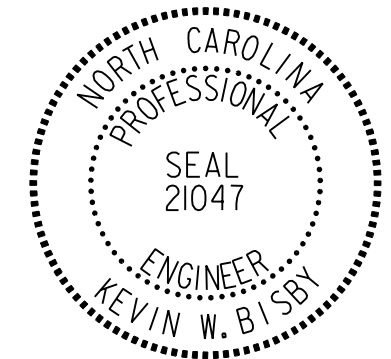
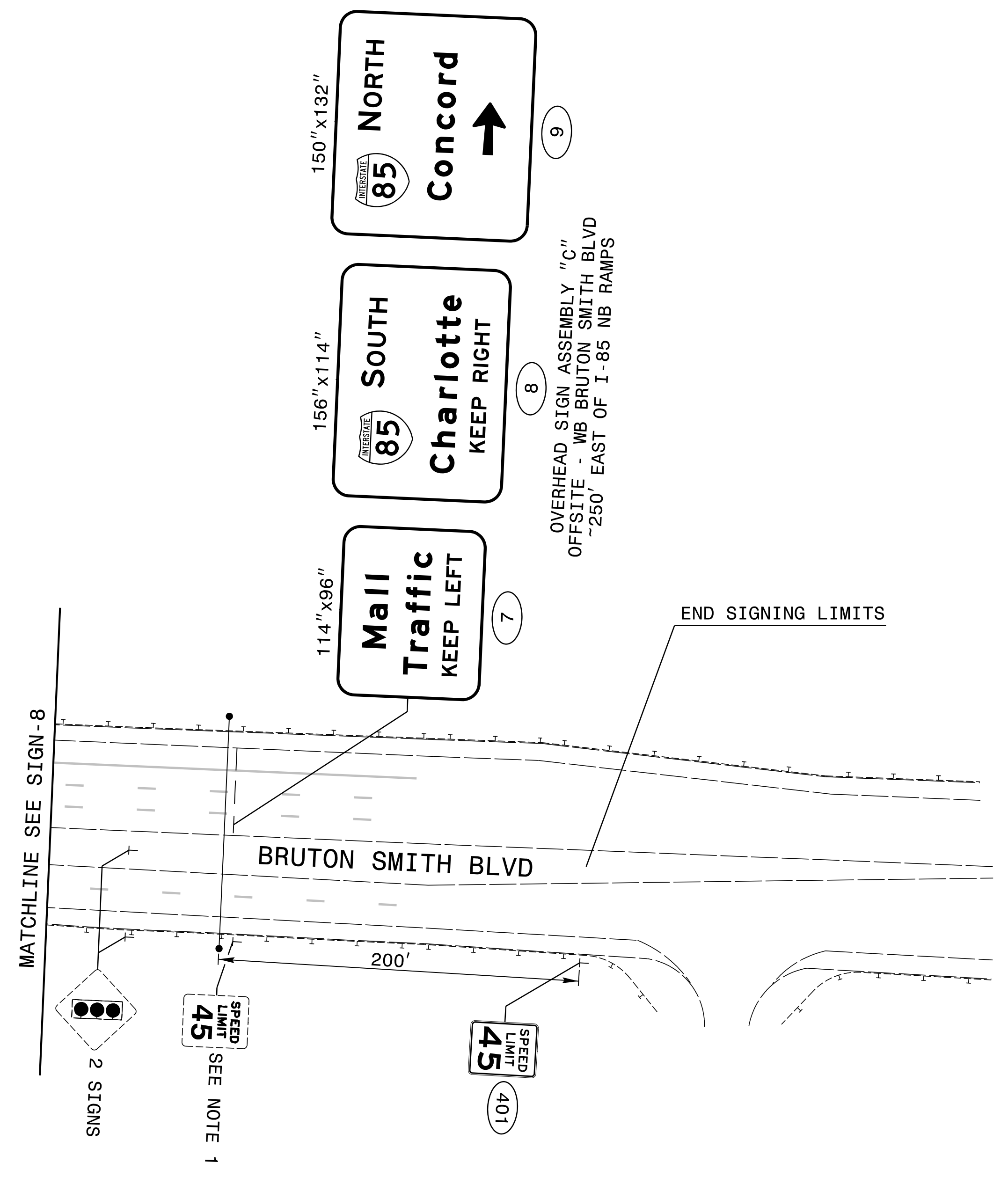
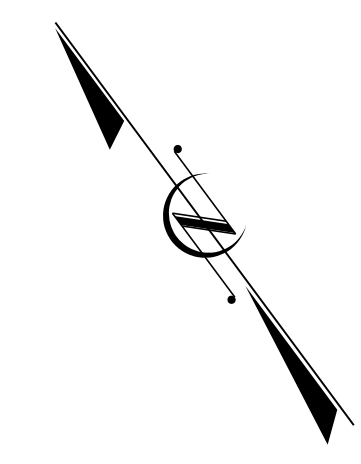
9/5/2017 10:56:06 AM U:\5806\SGN_PSH-06-dgn

PLANS PREPARED BY :



RUMMEL, KLEPPER & KAHL, LLP
 900 RIDGEFIELD DRIVE SUITE 350
 RALEIGH, NORTH CAROLINA 27609-3960
 NC LICENSE NO. F-0112 • (919) 878-9560

**EXISTING & PROPOSED SIGNS
-L- EAST OF I-85 NB RAMPS**

**DOCUMENT NOT CONSIDERED FINAL
UNLESS ALL SIGNATURES COMPLETED**

PROJECT REFERENCE NO. U-5806 SHEET NO. SIGN-10

APPROVED: *Kevin W. Bisby*
DATE: 9/5/2017

SEAL
NORTH CAROLINA
PROFESSIONAL
ENGINEER
SEAL
21047
KEVIN W. BISBY

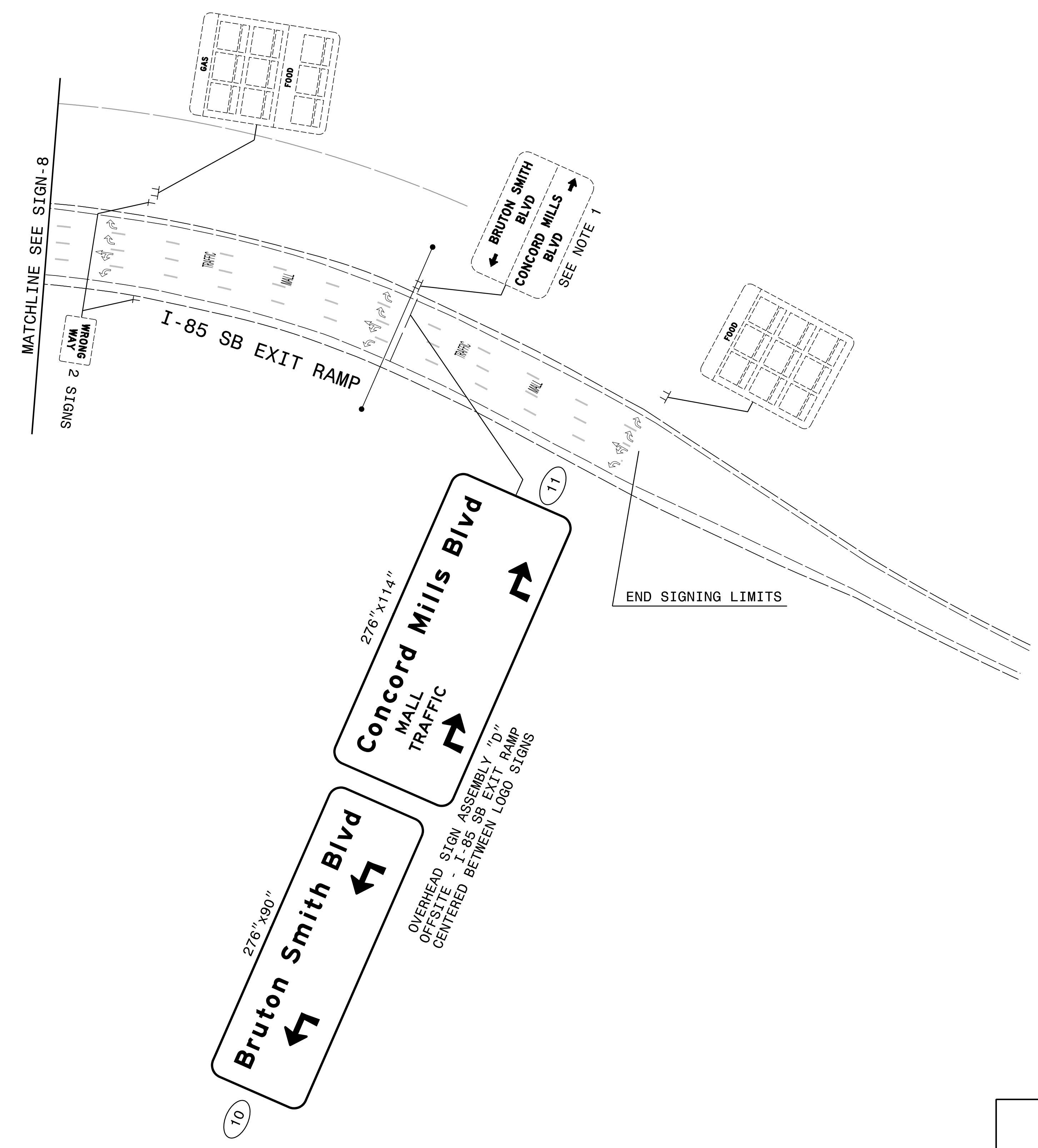
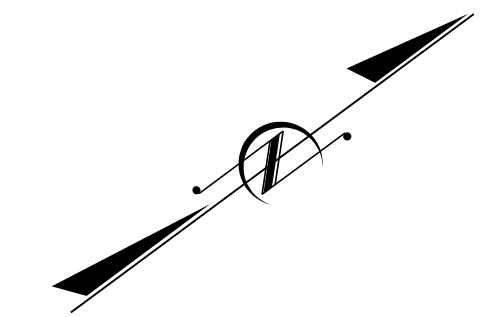

9/5/2017
U5806-SGN_PSH-10.dgn
klaus

PLANS PREPARED BY :
RK&K
RUMMEL, KLEPPER & KAHL, LLP
900 RIDGEFIELD DRIVE SUITE 350
RALEIGH, NORTH CAROLINA 27609-3960
NC LICENSE NO. F-0112 • (919) 878-9560

**EXISTING & PROPOSED SIGNS
I-85 SB EXIT RAMP**