

BRIDGE @ STA. 35+12.05 -Y8RPDB-	4 INCH SLOPE PROTECTION	* WELDED WIRE FABRIC 60 INCHES WIDE
	SQUARE YARDS	APPROX. L.F.
END BENT 2	355	710

\* QUANTITY SHOWN IS BASED ON 5' POURS.

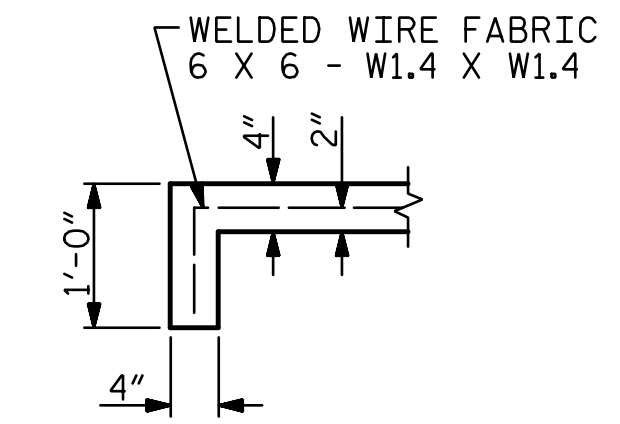
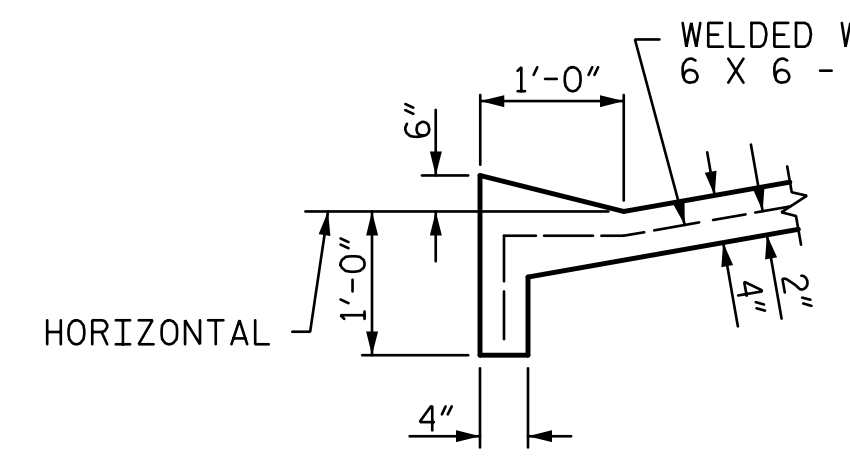
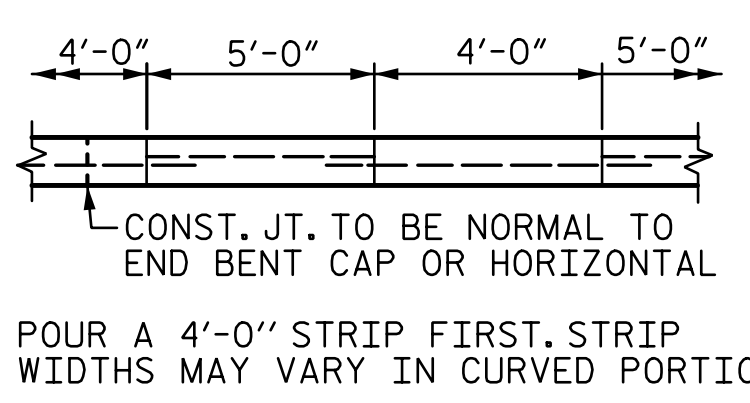

GENERAL NOTES

STRAIGHT EDGING WILL NOT BE REQUIRED UNLESS, IN THE OPINION OF THE ENGINEER, VISUAL INSPECTION INDICATES A NEED FOR IT. MEASUREMENT AND PAYMENT SHALL BE AS PRESCRIBED IN SECTION 462 OF THE STANDARD SPECIFICATIONS. FOR BERM WIDTH, SEE GENERAL DRAWING.

SLOPE PROTECTION SHALL CONSIST OF 4" POURED-IN-PLACE CONCRETE PAVING AS SHOWN IN THE DETAILS ON THIS SHEET. CONCRETE SHALL BE CLASS "B". THE CONCRETE SURFACE SHALL BE FLOATED WITH A WOODEN FLOAT AND FINISHED. WELDED WIRE FABRIC REINFORCING SHALL BE 6 X 6 - W1.4 X W1.4, 60" WIDE. SLOPE PROTECTION SHALL BE POURED IN 5' STRIPS AS SHOWN IN THE "POURING DETAIL" WITH 2'-0" LONG #4 BARS PLACED ALONG THE SLOPE BETWEEN STRIPS AT 1'-6" MAXIMUM SPACING. SLOPE PROTECTION MAY BE POURED IN ALTERNATE 4' AND 5' STRIPS AS SHOWN IN THE "OPTIONAL POURING DETAIL" WITH ADJACENT RUNS OF WELDED WIRE FABRIC LAPPING AT LEAST 6". THE COST OF THE WELDED WIRE FABRIC AND #4 BARS, IF USED, SHALL BE INCLUDED IN THE CONTRACT UNIT PRICE BID PER SQUARE YARD FOR SLOPE PROTECTION.

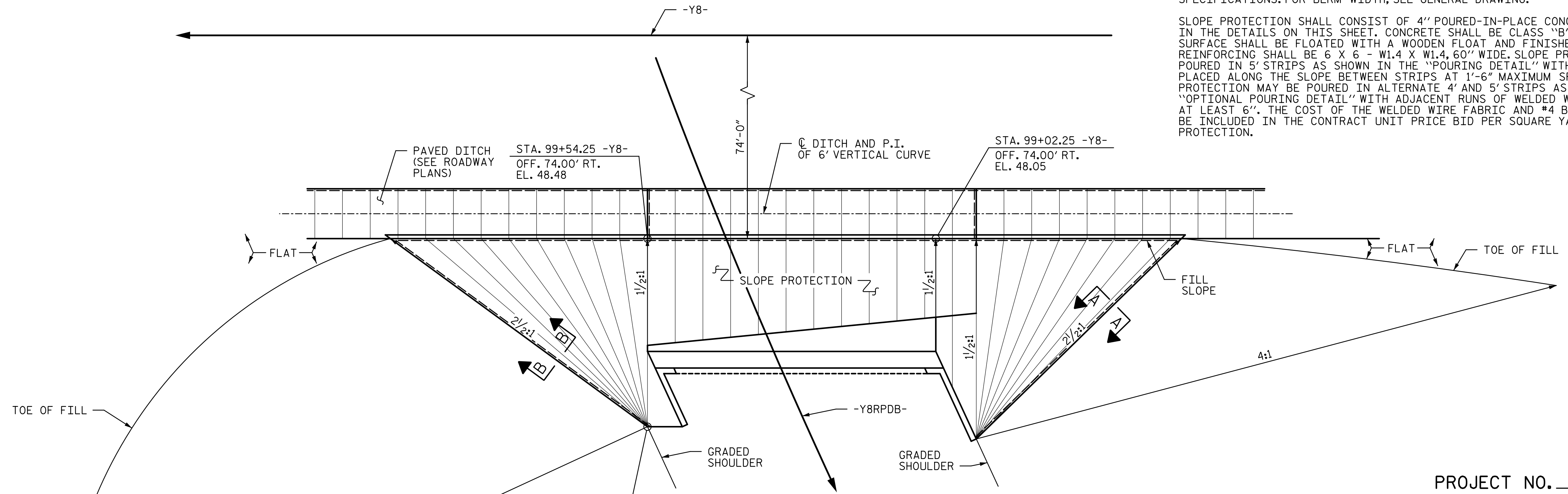

PROJECT NO. U-4751  
NEW HANOVER COUNTY  
STATION: 35+12.05 -Y8RPDB-  
SHEET 2 OF 2

DOCUMENT NOT CONSIDERED FINAL UNLESS ALL SIGNATURES COMPLETED		STATE OF NORTH CAROLINA DEPARTMENT OF TRANSPORTATION RALEIGH		SHEET NO. S4-34 TOTAL SHEETS 36
		SLOPE PROTECTION DETAILS		
		REVISIONS NO. BY: DATE: NO. BY: DATE:		
DRAWN BY: <u>MBC</u> DATE: <u>4-17</u> CHECKED BY: <u>TRL</u> DATE: <u>4-17</u>		DESIGN ENGINEER OF RECORD: <u>T. LAWS</u> DATE: <u>5-17</u>		

r:\404\_067\_U4751\_SML\_SP\_034\_640204.dgn 6/30/2017 13:12:40