

**This electronic collection of documents is provided
for the convenience of the user
and is Not a Certified Document –**

**The documents contained herein were originally issued
and sealed by the individuals whose names and license
numbers appear on each page, on the dates appearing
with their signature on that page.**

**This file or an individual page
shall not be considered a certified document.**

TIP NO. U-2579C	SHEET NO. PMP-1
APPROVED: <i>Andrew D. Klinksiek</i> DATE: 7/3/2017	
	
DOCUMENT NOT CONSIDERED FINAL UNLESS ALL SIGNATURES COMPLETED	

**STATE OF NORTH CAROLINA
DEPARTMENT OF TRANSPORTATION**

**PAVEMENT MARKING PLAN
FORSYTH COUNTY**

T.I.P.: U-2579C

INDEX

SHEET NO.	DESCRIPTION
PMP-1	PAVEMENT MARKING PLAN COVER SHEET
PMP-1A	FINAL PAVEMENT MARKING SCHEDULE AND LEGEND
PMP-2	LANE DROPS
PMP-2A	PAVEMENT MARKINGS - SIDE BY SIDE ON/OFF RAMP PAVEMENT MARKING LANE TREATMENT
PMP-2B	PAVEMENT MARKINGS - SYMBOLS AND WORD MESSAGES
PMP-3 THRU PMP-22	PAVEMENT MARKING DETAIL

ROADWAY STANDARD DRAWING

THE FOLLOWING ROADWAY STANDARDS AS APPEAR IN "ROADWAY STANDARD DRAWINGS" - PROJECT SERVICES UNIT - N.C. DEPARTMENT OF TRANSPORTATION - RALEIGH, N.C., DATED JANUARY 2012 ARE APPLICABLE TO THIS PROJECT AND BY REFERENCE HEREBY ARE CONSIDERED A PART OF THESE PLANS:

STD. NO.	TITLE
1205.01	PAVEMENT MARKINGS - LINE TYPES AND OFFSETS
1205.02	PAVEMENT MARKINGS - TWO-LANE AND MULTILANE ROADWAYS
1205.03	PAVEMENT MARKINGS - EXIT AND ENTRANCE RAMP
1205.04	PAVEMENT MARKINGS - INTERSECTIONS
1205.05	PAVEMENT MARKINGS - TURN LANES
1205.06	PAVEMENT MARKINGS - LANE DROPS
1205.08	PAVEMENT MARKINGS - SYMBOLS AND WORD MESSAGES
1205.09	PAVEMENT MARKINGS - PAINTED ISLANDS
1205.12	PAVEMENT MARKINGS - BRIDGES
1205.13	PAVEMENT MARKINGS - LANE REDUCTIONS
1250.01	RAISED PAVEMENT MARKERS - INSTALLATION SPACING
1251.01	RAISED PAVEMENT MARKERS - PERMANENT AND TEMPORARY
1253.01	RAISED PAVEMENT MARKERS - SNOWPLOWABLE
1261.01	GUARDRAIL AND BARRIER DELINEATORS - INSTALLATION SPACING
1261.02	GUARDRAIL AND BARRIER DELINEATORS - TYPES AND MOUNTING
1262.01	GUARDRAIL END DELINEATION
1264.01	OBJECT MARKERS - TYPES
1264.02	OBJECT MARKERS - INSTALLATION
1267.01	FLEXIBLE DELINEATORS - INSTALLATION
1267.02	FLEXIBLE DELINEATORS - SPACING TABLES
1267.03	FLEXIBLE DELINEATORS - INTERCHANGE PLACEMENT

GENERAL NOTES

- THE FOLLOWING GENERAL NOTES APPLY AT ALL TIMES FOR THE DURATION OF THE CONSTRUCTION PROJECT, EXCEPT WHEN OTHERWISE NOTED IN THE PLAN, OR DIRECTED BY THE ENGINEER.
- A) INSTALL PAVEMENT MARKINGS AND PAVEMENT MARKERS ON THE FINAL SURFACE AS FOLLOWS:
- | ROAD NAME | MARKING | MARKER |
|--------------|---|----------------|
| -L- & RAMPS | POLYUREA W/ HIGHLY REFLECTIVE ELEMENTS (EXCEPT AS NOTED ON PLANS) | SNOWPLOWABLE |
| ALL Y-LINES | POLYUREA W/ HIGHLY REFLECTIVE ELEMENTS | MATCH EXISTING |
| BRIDGE DECKS | POLYUREA W/ HIGHLY REFLECTIVE ELEMENTS | RAISED |
- B) PLACE TWO APPLICATIONS OF PAINT PAVEMENT MARKINGS ON THE FINAL WEARING SURFACE. PLACE THE SECOND APPLICATION OF PAINT UPON SUFFICIENT DRYING TIME OF THE FIRST.
- C) TIE PROPOSED PAVEMENT MARKING LINES TO EXISTING PAVEMENT MARKING LINES.
- D) REMOVE/REPLACE ANY CONFLICTING/DAMAGED PAVEMENT MARKINGS AND MARKERS.
- E) PASSING ZONES WILL BE DETERMINED IN THE FIELD AND MUST BE APPROVED BY THE ENGINEER.
- F) STOP BAR LOCATION AT NON-SIGNALIZED INTERSECTIONS MAY BE ADJUSTED AS DIRECTED BY THE ENGINEER.
- G) REMOVE ALL RESIDUE AND SURFACE LAITANCE BY ACCEPTABLE METHODS ON CONCRETE BRIDGE DECKS PRIOR TO PLACING POLYUREA PAVEMENT MARKING MATERIAL.
- H) UNLESS OTHERWISE SPECIFIED, HEATED-IN-PLACE THERMOPLASTIC MAY BE USED IN LIEU OF EXTRUDED THERMOPLASTIC FOR STOP BARS, SYMBOLS, CHARACTERS AND DIAGONALS. IF HEATED-IN-PLACE IS USED, IT SHALL BE PAID FOR USING THE EXTRUDED THERMOPLASTIC PAY ITEM.

FLEXIBLE DELINEATOR NOTE

INSTALL FLEXIBLE DELINEATORS ALONG THE LEFT SIDE OF LOOPS AND RIGHT SIDE OF RAMPS. ORIENT DELINEATORS FOR MAXIMUM VISIBILITY FOR APPROACHING VEHICLES. REFER TO ROADWAY STANDARD DRAWINGS FOR SPACING AND PLACEMENT.

CONTRACT:

PLAN REVIEWED BY: N.C.D.O.T. SIGNING AND DELINEATION UNIT

<i>Kelvin Jordan</i>	SIGNING & DELINEATION REGIONAL ENGINEER
<i>Ashley Kidd</i>	SIGNING & DELINEATION PROJECT DESIGN ENGINEER

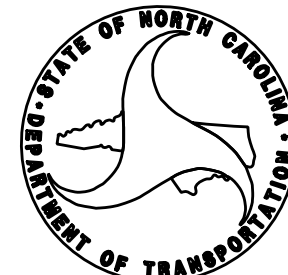

PLAN PREPARED BY: HNTB NORTH CAROLINA, P.C.

<i>A.D. Klinksiek, PE, PTOE</i>	PROJECT ENGINEER
<i>J.A. Phillips</i>	DESIGN TECHNICIAN

HNTB HNTB NORTH CAROLINA, P.C.
343 E Six Forks Road, Suite 200
Raleigh, North Carolina 27609
C-1554

FINAL PAVEMENT MARKING SCHEDULE

MATERIAL SYMBOL DESCRIPTION

PAVEMENT MARKING

POLYUREA (4") - WITH HIGHLY REFLECTIVE ELEMENTS

V8	2 FT - 6 FT WHITE MINISKIP
V9	2 FT - 6 FT YELLOW MINISKIP
VA	WHITE EDGELINE
VB	YELLOW EDGELINE
VD	3 FT - 9 FT WHITE MINISKIP
VE	WHITE SOLID LANE LINE
VI	DOUBLE YELLOW CENTERLINE

POLYUREA (6") - WITH HIGHLY REFLECTIVE ELEMENTS

V11	2 FT - 6FT WHITE MINISKIP
V12	2 FT - 6FT YELLOW MINISKIP
V16	DOUBLE YELLOW CENTERLINE
V6	WHITE EDGELINE
V7	YELLOW EDGELINE
VJ	10 FT WHITE SKIP
VK	3 FT - 9 FT WHITE MINISKIP
VL	WHITE SOLID LANE LINE

POLYUREA (12") - WITH HIGHLY REFLECTIVE ELEMENTS

VS	WHITE GORE LINE
VT	WHITE SOLID LANE LINE - WIDE

THERMOPLASTIC (12", 90 MILS)

TV	YELLOW DIAGONAL
----	-----------------

THERMOPLASTIC (16", 120 MILS)

T1	WHITE LINE, RR X
----	------------------

THERMOPLASTIC (24", 120 MILS)

T2	WHITE STOP BAR
----	----------------

PAINT (6")

P6	WHITE EDGELINE
P7	YELLOW EDGELINE
PK	3 FT- 9 FT WHITE MINISKIP

PAINT (12")

PV	YELLOW DIAGONAL
----	-----------------

THERMOPLASTIC PAVEMENT MARKING SYMBOL (90 MILS)

UA	LEFT TURN ARROW
UB	RIGHT TURN ARROW
UC	STRAIGHT ARROW
UP	MERGE ARROW
UQ	RAMP ARROW SYMBOL

PAINT PAVEMENT MARKING SYMBOL

QP	MERGE ARROW
----	-------------

THERMOPLASTIC PAVEMENT MARKING CHARACTER (120 MILS)

UI ONLY

PERMANENT RAISED PAVEMENT MARKERS (NOT SHOWN ON PLAN)

MA YELLOW & YELLOW
MB CRYSTAL & RED

SNOWPLOWABLE RAISED PAVEMENT MARKERS (NOT SHOWN ON PLAN)

MF CRYSTAL & RED

LEGEND

GENERAL

- ← DIRECTION OF TRAFFIC FLOW
- ↑ NORTH ARROW
- PROPOSED PVMT. - - - - - EXIST. PVMT.
- ⊙ TUBULAR MARKERS

PAVEMENT MARKINGS

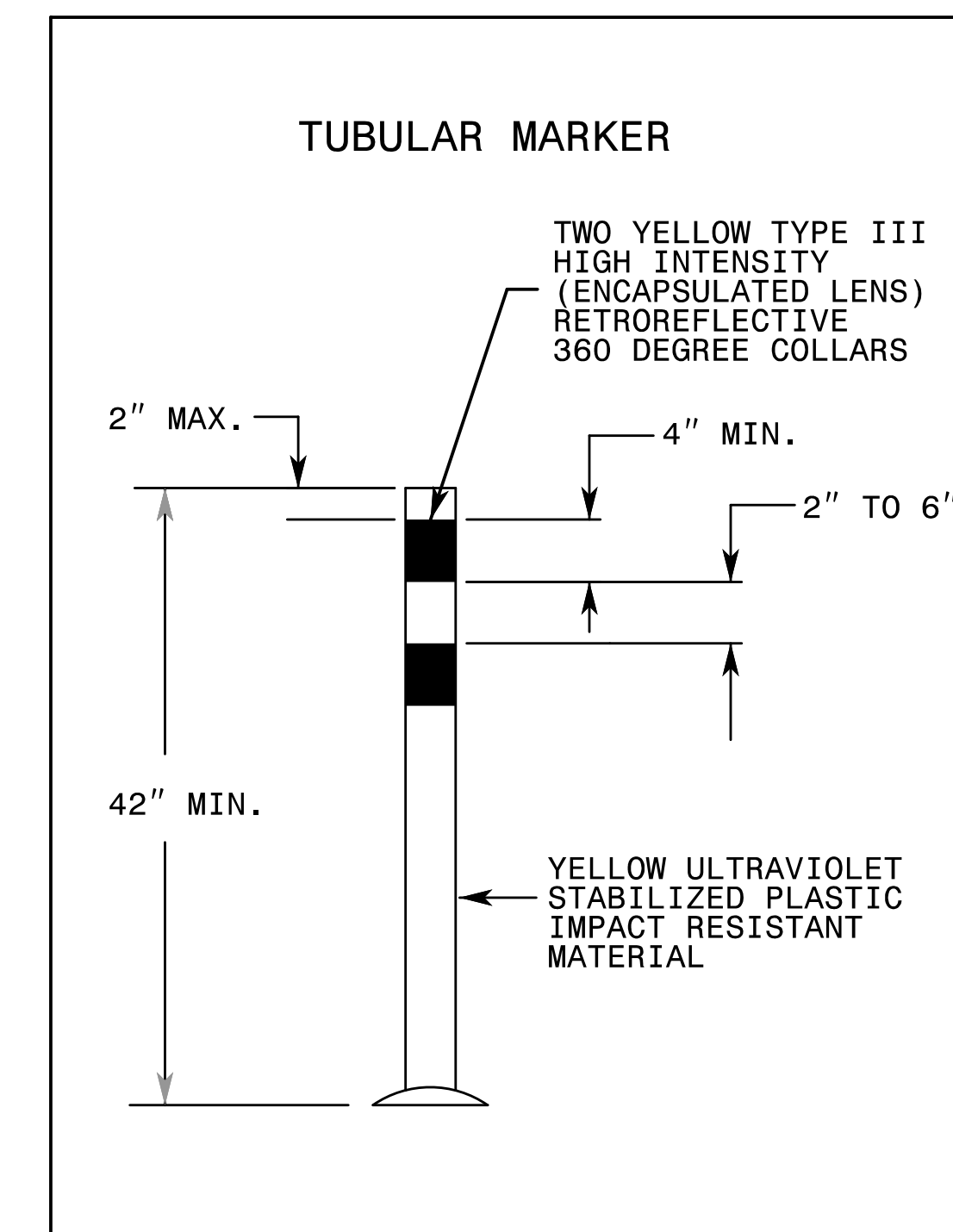
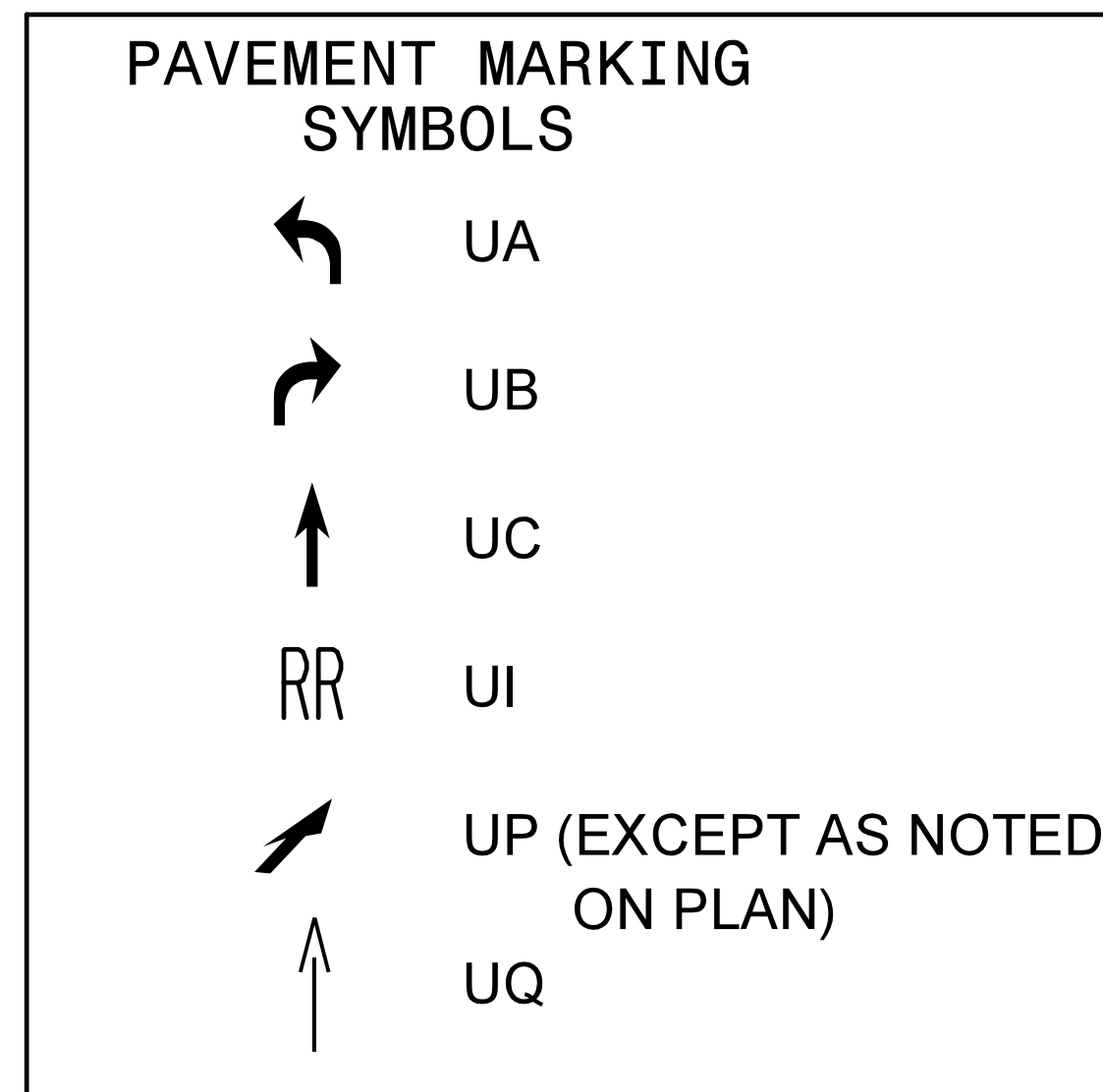

TIP NO. U-2579C	SHEET NO. PMP-1A
APPROVED: <i>Andrew D. Klinck</i> <small>DocuSigned by: Andrew D. Klinck E3078F8459E44B</small>	
DATE: 7/3/2017	
SEAL 	
DOCUMENT NOT CONSIDERED FINAL UNLESS ALL SIGNATURES COMPLETED	

i:\0614_PM\U-2579C_pmp_PMP_01_01a_title_notes.dgn
HNTB

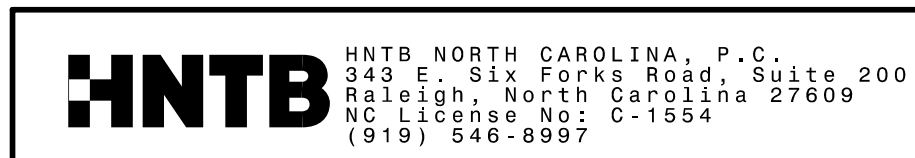

PAVEMENT MARKING SCHEDULE

TIP NO. U-2579C	SHEET NO. PMP-2
APPROVED: <i>Andrew D. Klinck</i> E3078F8459E44B	
DATE: 7/3/2017	
	
DOCUMENT NOT CONSIDERED FINAL UNLESS ALL SIGNATURES COMPLETED	

STATE OF NORTH CAROLINA
DEPT. OF TRANSPORTATION
DIVISION OF HIGHWAYS
RALEIGH, N.C.

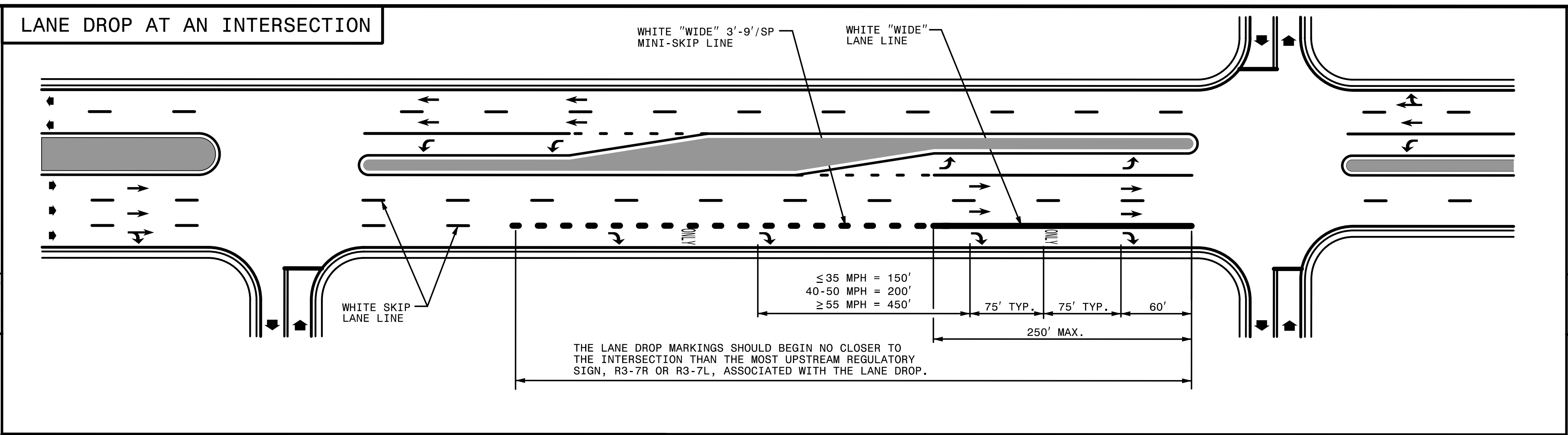

STATE OF NORTH CAROLINA
DEPT. OF TRANSPORTATION
DIVISION OF HIGHWAYS
RALEIGH, N.C.

ENGLISH DETAIL DRAWING FOR
PAVEMENT MARKINGS
LANE DROPS

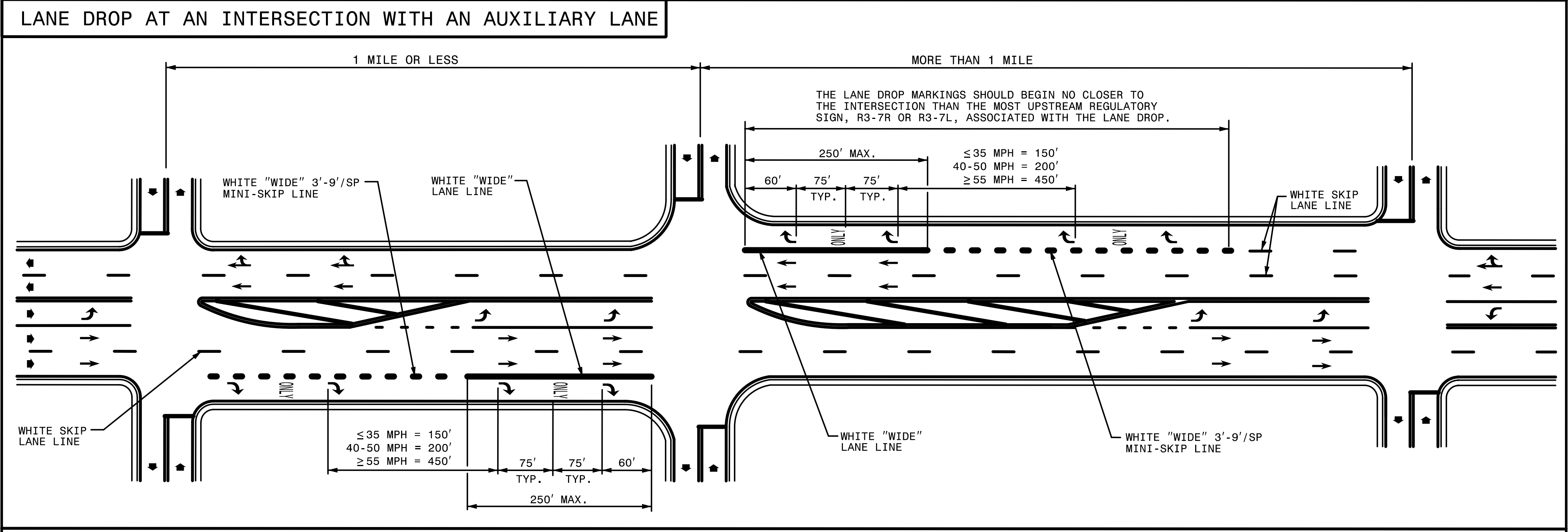

ENGLISH DETAIL DRAWING FOR
PAVEMENT MARKINGS
LANE DROPS

GENERAL NOTES:

- USE THE GUIDANCE SHOWN ON THE ABOVE DETAILS IN CONJUNCTION WITH INTERSECTION GUIDANCE SHOWN ON ROADWAY STANDARD DRAWING 1205.04.
- LANE LINES INDICATED AS "WIDE" SHALL BE AT LEAST TWICE THE WIDTH OF THE NORMAL LINE.

LEGEND	
W = WIDTH OF TRAVEL LANE	ONLY PAVEMENT MARKING SYMBOLS & CHARACTERS
➔ DIRECTION OF TRAFFIC FLOW	

SHEET 1 OF 3
1205D06

SHEET 1 OF 3
1205D06

11-06-2017 11:06 AM
C:\Users\jclark\OneDrive\Documents\1205D06.dwg
HNTB

HNTB
HNTB NORTH CAROLINA, P.C.
343 E. SIX FORKS ROAD, SUITE 200
RALEIGH, NORTH CAROLINA 27609
NC LICENSE NO: C-1554
(919) 546-8997

**REVISED PAVEMENT MARKING
ROADWAY STANDARD DRAWING**

TIP NO. U-2579C	SHEET NO. PMP-2A
APPROVED: <i>Andrew D. Klinck</i> E3078F8459E44B	
DATE: 7/3/2017	
	
DOCUMENT NOT CONSIDERED FINAL UNLESS ALL SIGNATURES COMPLETED	

STATE OF NORTH CAROLINA
 DEPT. OF TRANSPORTATION
 DIVISION OF HIGHWAYS
 RALEIGH, N.C.

8-16

ENGLISH STANDARD DETAIL FOR
PAVEMENT MARKINGS
 SIDE-BY-SIDE ON/OFF RAMPS
 PAVEMENT MARKING LANE TREATMENT

SHEET 1 OF 1

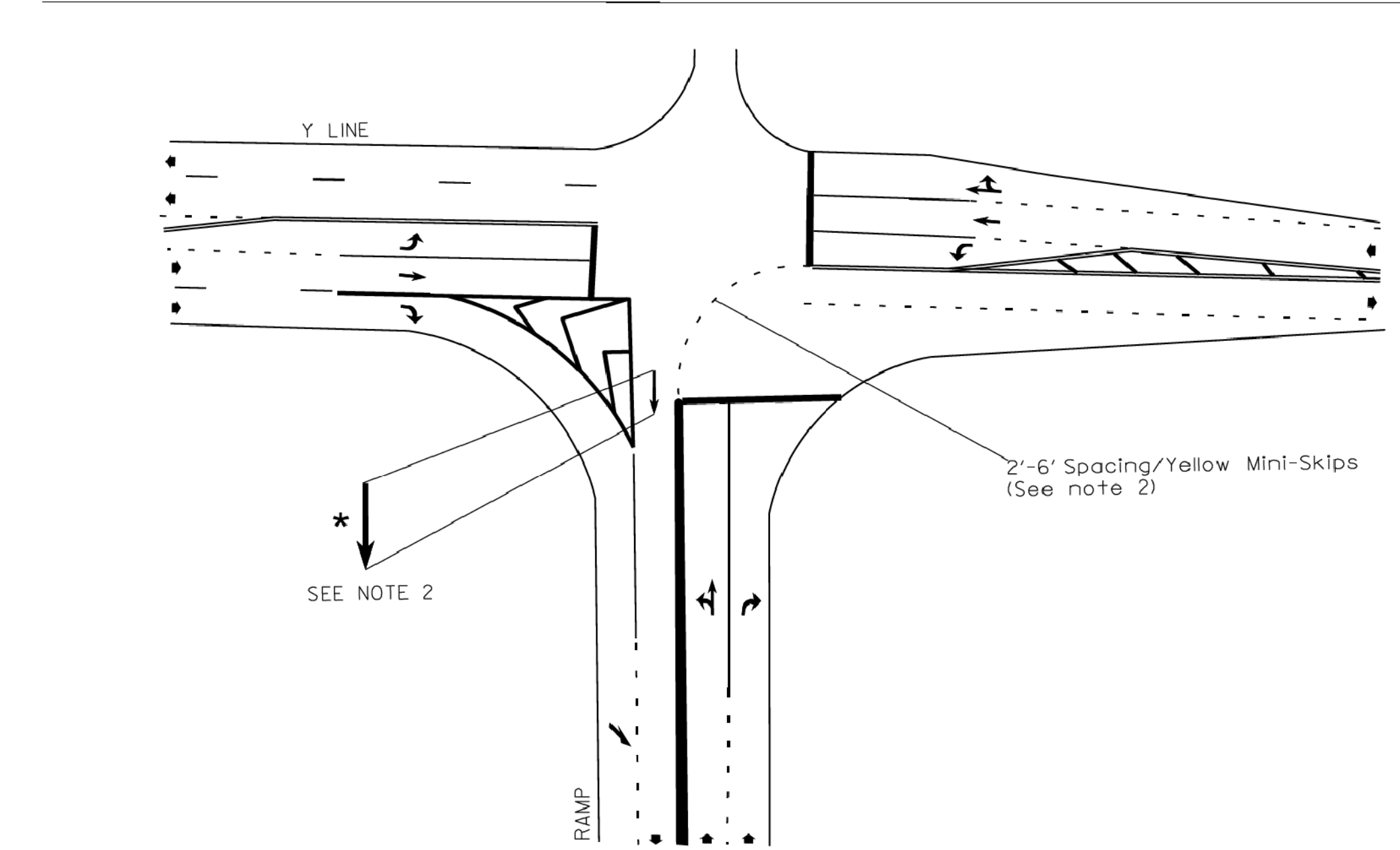
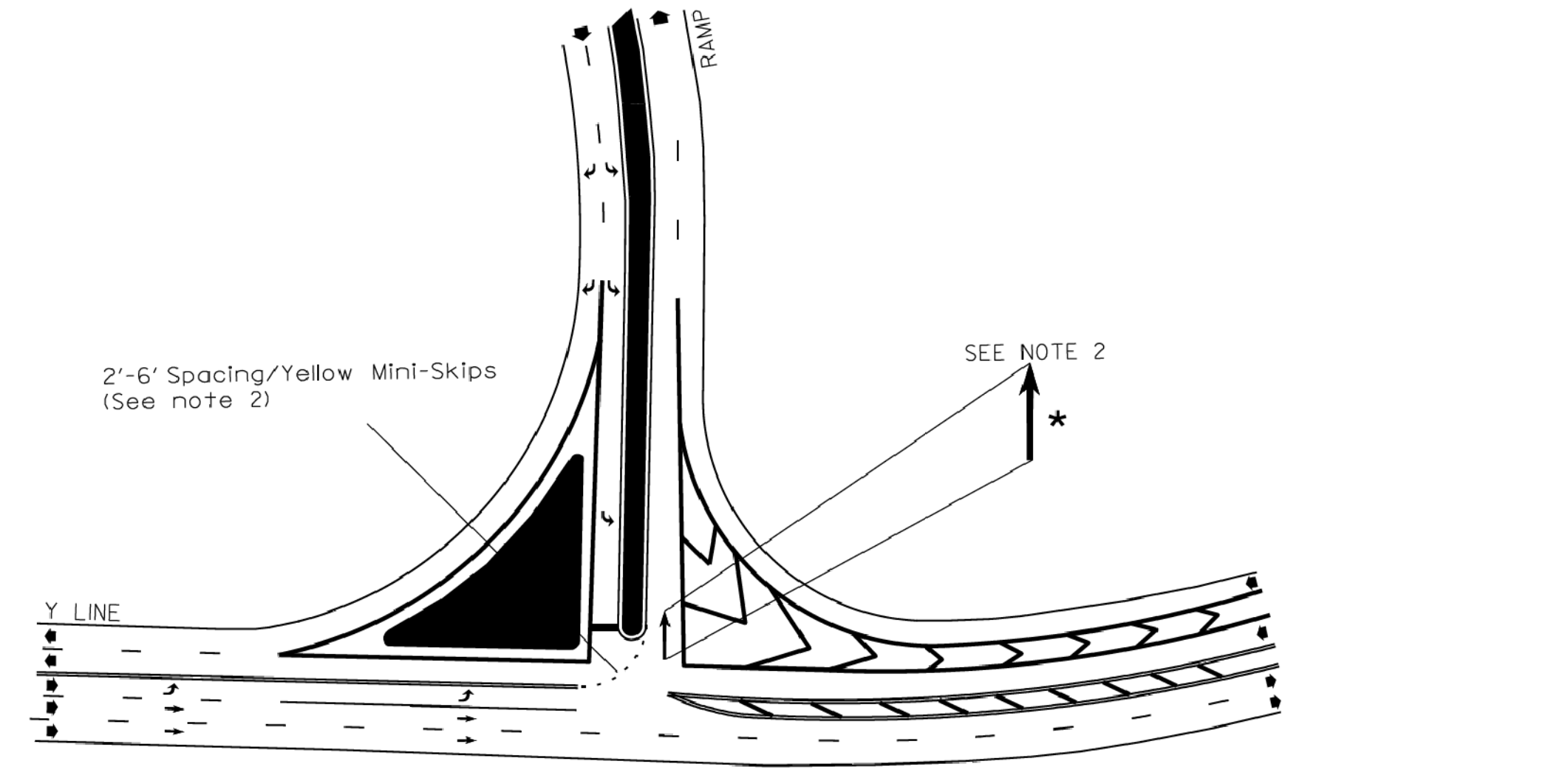

NOTES:

- REFER TO THE 2012 NCDOT ROADWAY STANDARD DRAWINGS AND THE PAVEMENT MARKING PLANS FOR ADDITIONAL PAVEMENT MARKING GUIDANCE ON THIS SHEET.
- PROPOSED YELLOW MINI-SKIPS AND ELONGATED STRAIGHT ARROW SYMBOL MATERIALS SHALL BE PER THE PAVEMENT MARKING PLAN OR AS DIRECTED BY THE ENGINEER. ELONGATED STRAIGHT ARROW SHALL BE APPROXIMATELY 12' LONG AND SHALL BE PAID AS A SYMBOL.

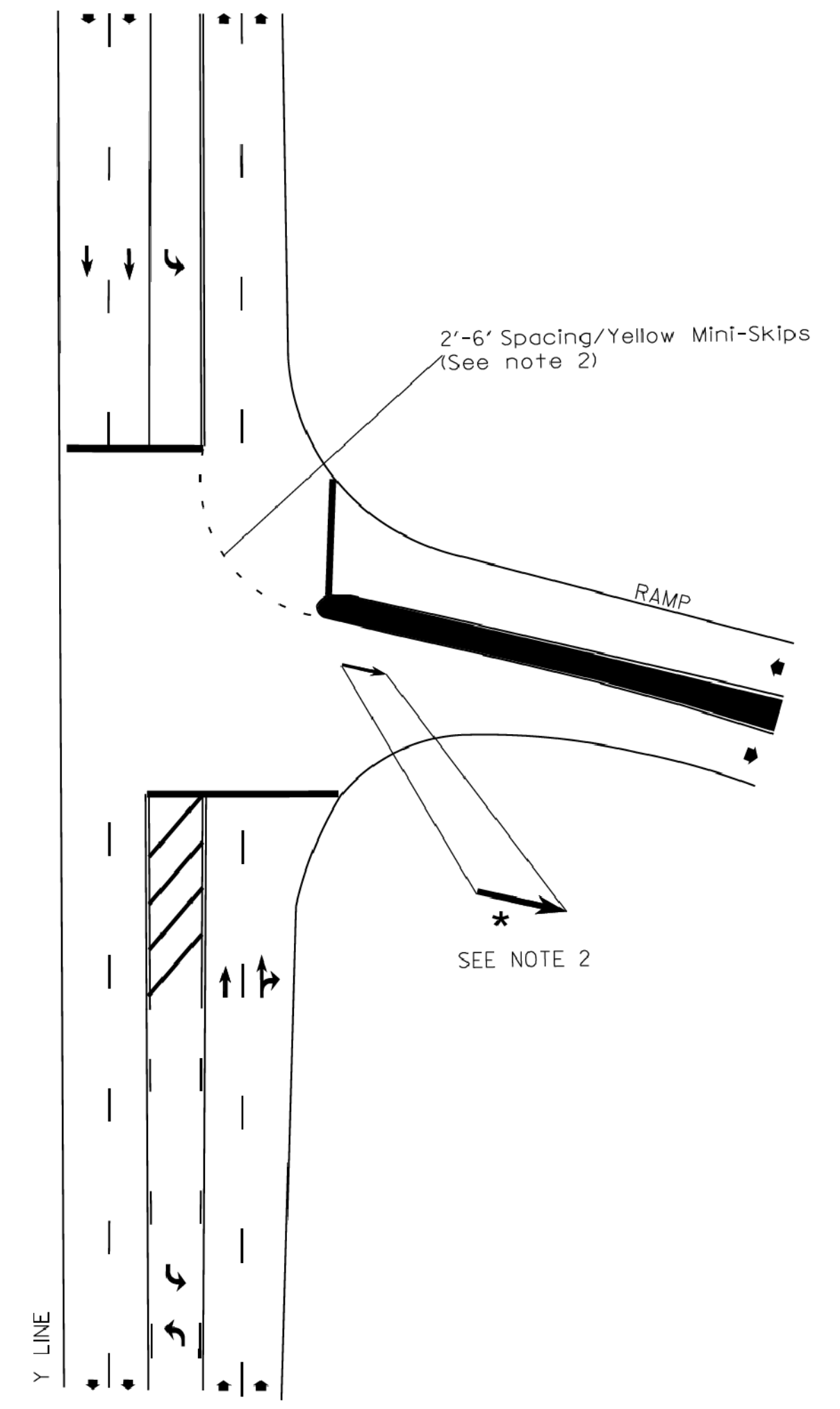

LEGEND	
	DIRECTION OF TRAFFIC FLOW
	PAVEMENT MARKING SYMBOLS
	OPTIONAL

STATE OF NORTH CAROLINA
 DEPT. OF TRANSPORTATION
 DIVISION OF HIGHWAYS
 RALEIGH, N.C.

8-16

ENGLISH STANDARD DETAIL FOR
PAVEMENT MARKINGS
 SIDE-BY-SIDE ON/OFF RAMP
 PAVEMENT MARKING LANE TREATMENT

SHEET 1 OF 1

I:\0616_PM
 \PMP\U2579C_PMP_02_r.sd.dgn
 HNTB

HNTB HNTB NORTH CAROLINA, P.C.
 343 E. SIX FORKS ROAD, SUITE 200
 RALEIGH, NORTH CAROLINA 27609
 NC LICENSE NO: C-1554
 (919) 546-8997

PAVEMENT MARKINGS
SIDE BY SIDE ON/OFF RAMP
PAVEMENT MARKING LANE TREATMENT

TIP NO. U-2579C	SHEET NO. PMP-3
APPROVED: <i>Andrew D. Klinck</i> E3078F8459E44B	
DATE: 7/3/2017	
SEAL	
	
DOCUMENT NOT CONSIDERED FINAL UNLESS ALL SIGNATURES COMPLETED	

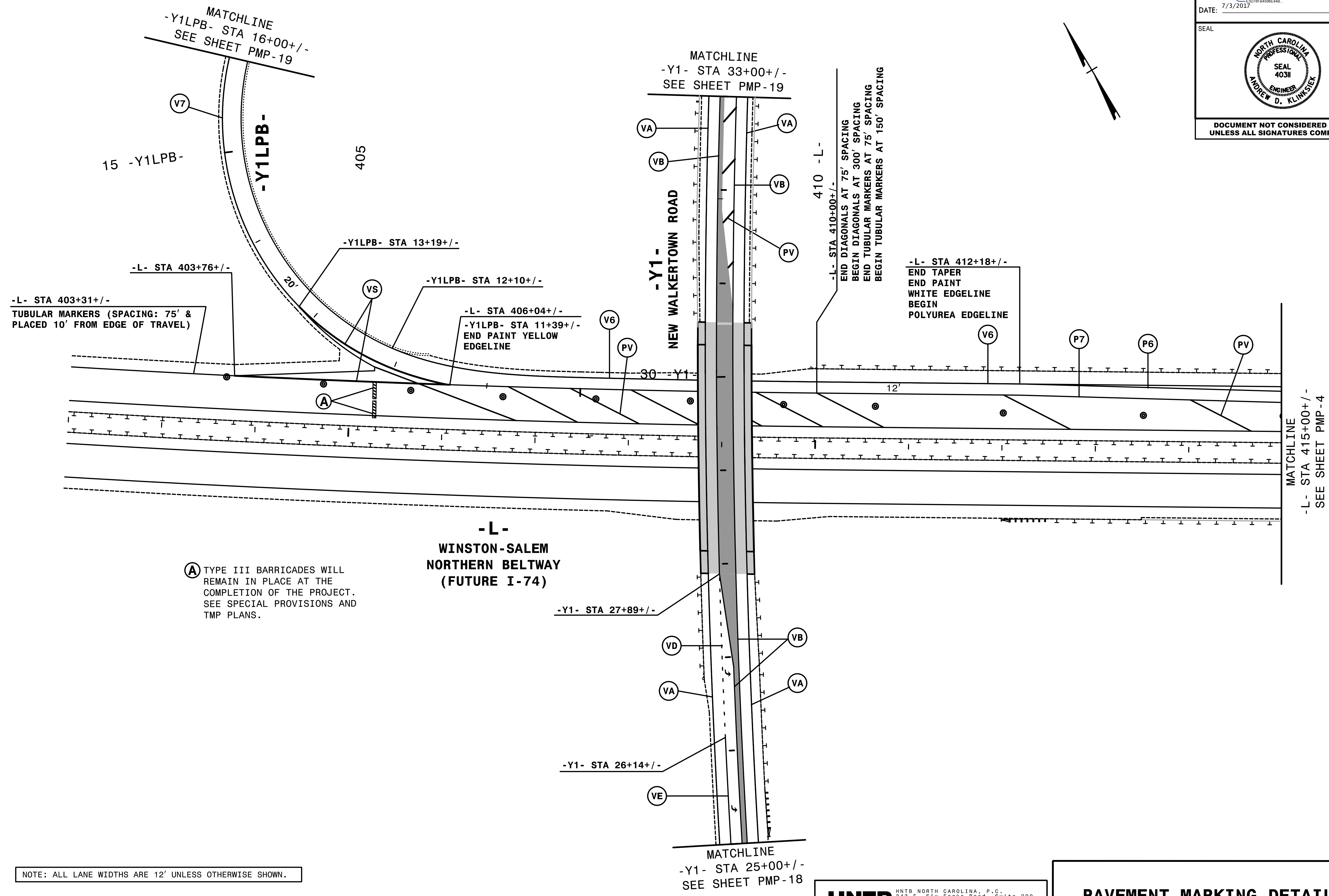

NOTE: ALL LANE WIDTHS ARE 12' UNLESS OTHERWISE SHOWN.

A TYPE III BARRICADES WILL REMAIN IN PLACE AT THE COMPLETION OF THE PROJECT. SEE SPECIAL PROVISIONS AND TMP PLANS.

-L- WINSTON-SALEM NORTHERN BELTWAY (FUTURE I-74)

MATCHLINE -Y1- STA 33+00+/- SEE SHEET PMP-19

MATCHLINE -Y1- STA 25+00+/- SEE SHEET PMP-18

MATCHLINE -L- STA 415+00+/- SEE SHEET PMP-4

I:\46430_PMP\Y\2579C\U-2579C_PMP_03.dgn
HNTB

HNTB HNTB NORTH CAROLINA, P.C.
343 E. SIX FORKS ROAD, SUITE 200
RALEIGH, NORTH CAROLINA 27609
NC LICENSE NO: C-1554
(919) 546-8997

PAVEMENT MARKING DETAIL

TIP NO. U-2579C	SHEET NO. PMP-4
APPROVED: <i>Andrew D. Klinck</i> E3078F8459E44B	
DATE: 7/3/2017	
	
DOCUMENT NOT CONSIDERED FINAL UNLESS ALL SIGNATURES COMPLETED	

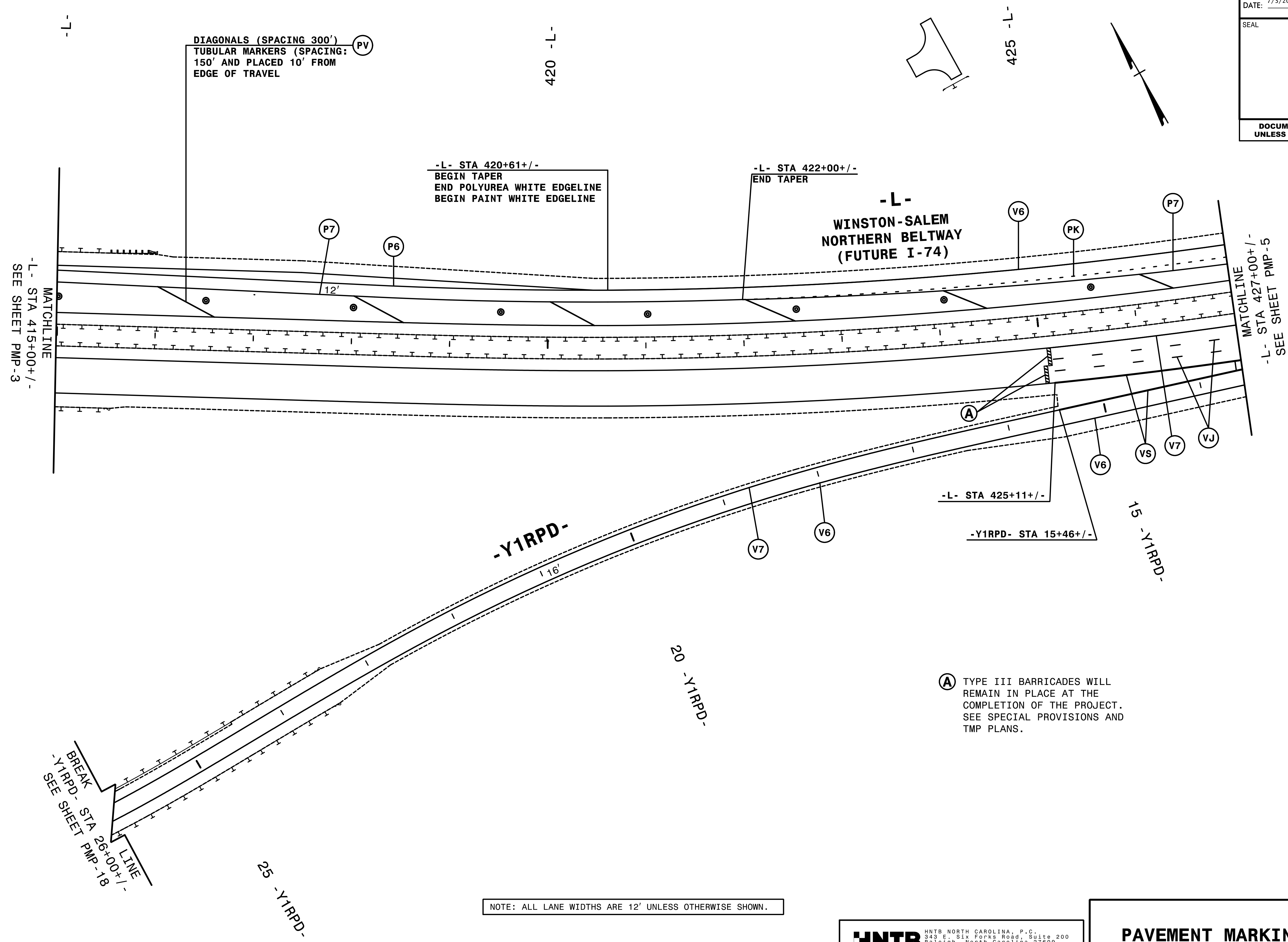

(A) TYPE III BARRICADES WILL REMAIN IN PLACE AT THE COMPLETION OF THE PROJECT. SEE SPECIAL PROVISIONS AND TMP PLANS.

NOTE: ALL LANE WIDTHS ARE 12' UNLESS OTHERWISE SHOWN.

HNTB
 HNTB NORTH CAROLINA, P.C.
 343 E. SIX FORKS ROAD, SUITE 200
 RALEIGH, NORTH CAROLINA 27609
 NC LICENSE NO: C-1554
 (919) 546-8997

PAVEMENT MARKING DETAIL

1:46:32 PM
 I:\PMP\U-2579C\pmp_04.dgn
 HNTB

TIP NO. U-2579C	SHEET NO. PMP-5
APPROVED: <i>Andrew D. Klinck</i> E3078F8459E44B	
DATE: 7/3/2017	
	
DOCUMENT NOT CONSIDERED FINAL UNLESS ALL SIGNATURES COMPLETED	

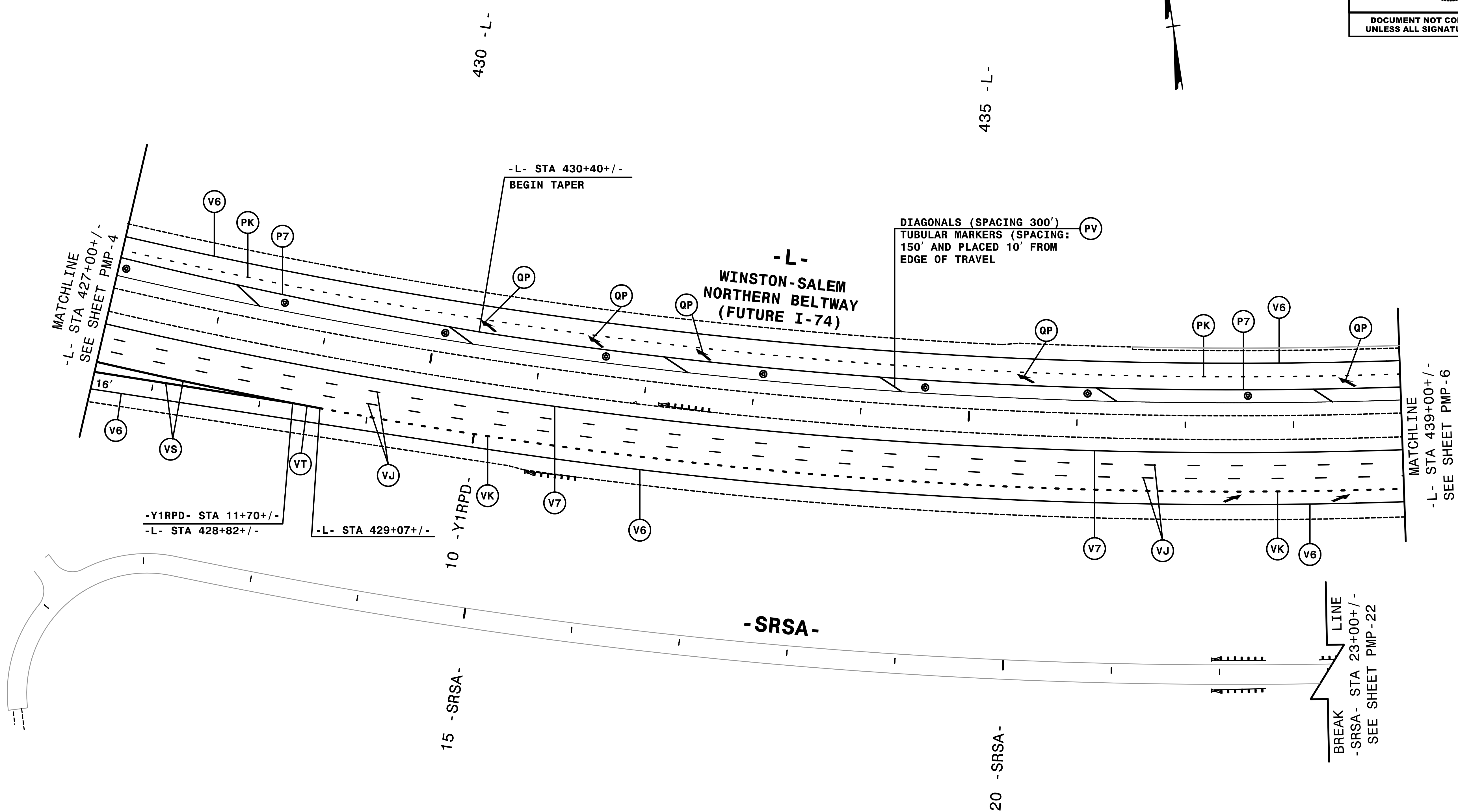

NOTE: ALL LANE WIDTHS ARE 12' UNLESS OTHERWISE SHOWN.

I:\0634_PMP\0634_PMP\U-2579C.dmp_PMP_05.dgn
HNTB

HNTB HNTB NORTH CAROLINA, P.C.
343 E. Six Forks Road, Suite 200
Raleigh, North Carolina 27609
NC License No: C-1554
(919) 546-8997

PAVEMENT MARKING DETAIL

TIP NO. U-2579C	SHEET NO. PMP-6
APPROVED: <i>Andrew D. Klinck</i> E3078F84598E44B	
DATE: 7/3/2017	
	
DOCUMENT NOT CONSIDERED FINAL UNLESS ALL SIGNATURES COMPLETED	

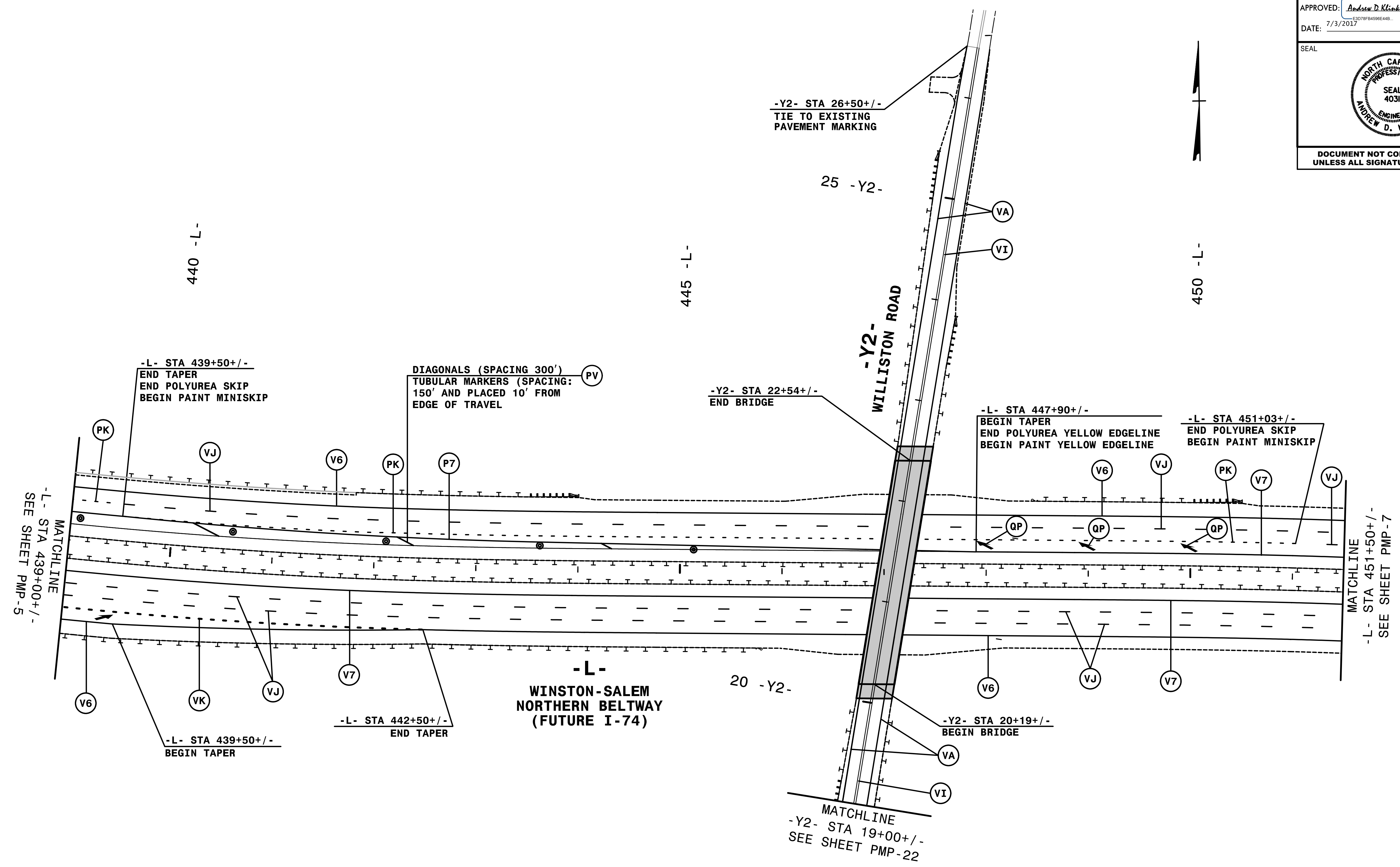

NOTE: ALL LANE WIDTHS ARE 12' UNLESS OTHERWISE SHOWN.

HNTB
 HNTB NORTH CAROLINA, P.C.
 343 E. SIX FORKS ROAD, SUITE 200
 RALEIGH, NORTH CAROLINA 27609
 NC License No: C-1554
 (919) 546-8997

PAVEMENT MARKING DETAIL

I:\06437 PM
V\PM\U-2579C-dmp_PMP_06.dgn
HNTB

TIP NO. U-2579C	SHEET NO. PMP-7
APPROVED: <i>Andrew D. Klinck</i> <small>E3078F84598E44B</small>	
DATE: 7/3/2017	
	
DOCUMENT NOT CONSIDERED FINAL UNLESS ALL SIGNATURES COMPLETED	

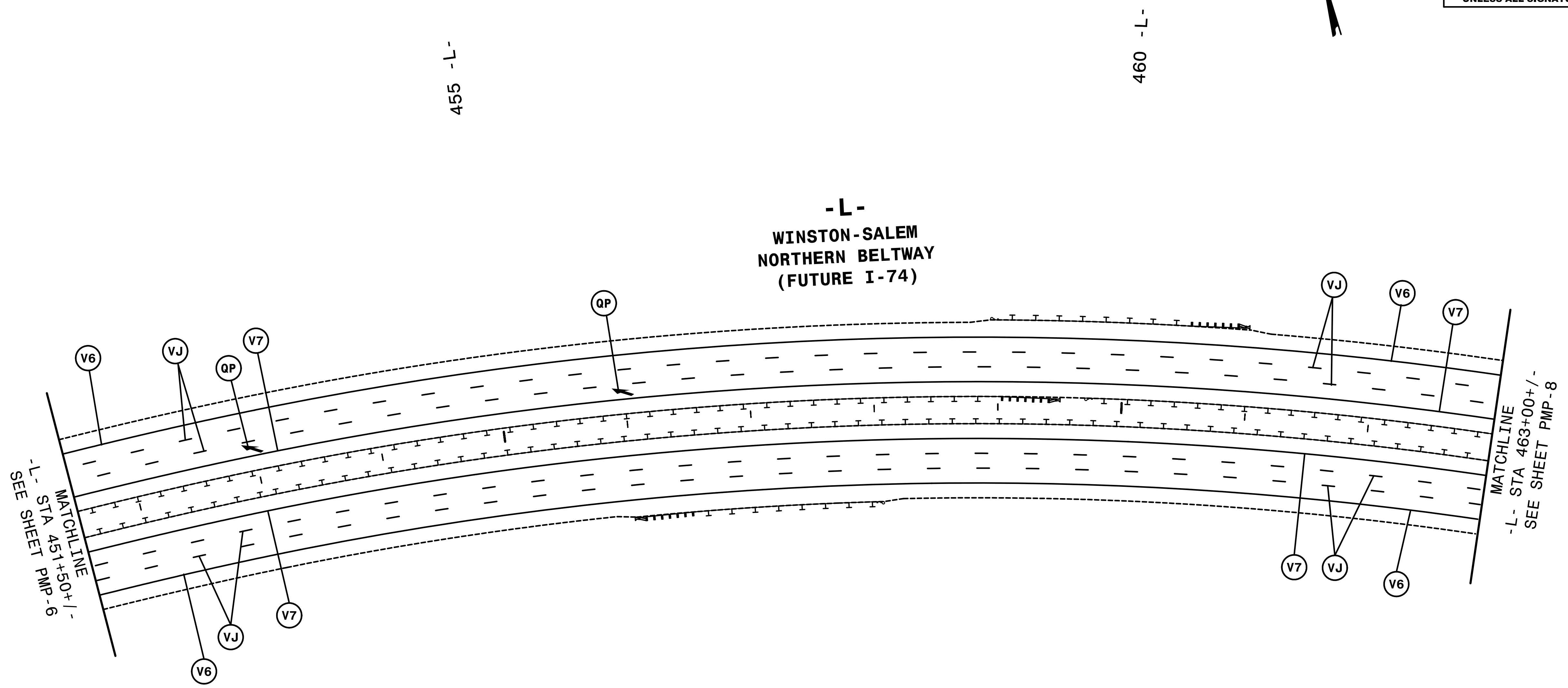

NOTE: ALL LANE WIDTHS ARE 12' UNLESS OTHERWISE SHOWN.

HNTB
 HNTB NORTH CAROLINA, P.C.
 343 E. Six Forks Road, Suite 200
 Raleigh, North Carolina 27609
 NC License No: C-1554
 (919) 546-8997

PAVEMENT MARKING DETAIL

I:\06-139_PMP\U-2579C.dmp_PMP_07.dgn
HNTB

TIP NO. U-2579C	SHEET NO. PMP-8
APPROVED: <i>Andrew D. Klinck</i> <small>E3078F8459E44B</small>	
DATE: 7/3/2017	
	
DOCUMENT NOT CONSIDERED FINAL UNLESS ALL SIGNATURES COMPLETED	

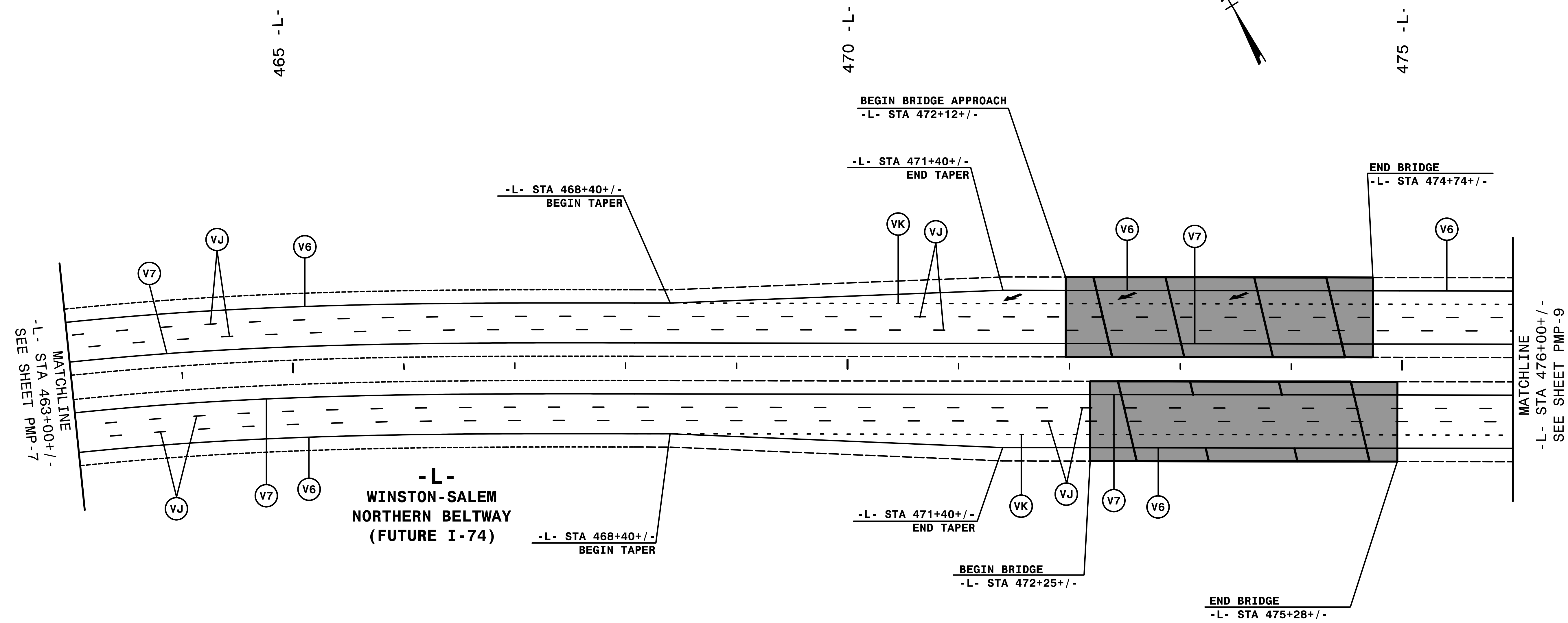

NOTE: ALL LANE WIDTHS ARE 12' UNLESS OTHERWISE SHOWN.

HNTB
 HNTB NORTH CAROLINA, P.C.
 343 E. SIX FORKS ROAD, SUITE 200
 RALEIGH, NORTH CAROLINA 27609
 NC LICENSE NO: C-1554
 (919) 546-8997

PAVEMENT MARKING DETAIL

I:\06-41\PM_V\PM_PU_U-2579C_dmp_PMP_08.dgn
HNTB

TIP NO. U-2579C	SHEET NO. PMP-9
APPROVED: <i>Andrew D. Klinck</i> E3078F8459E44B	
DATE: 7/3/2017	
SEAL 	
DOCUMENT NOT CONSIDERED FINAL UNLESS ALL SIGNATURES COMPLETED	

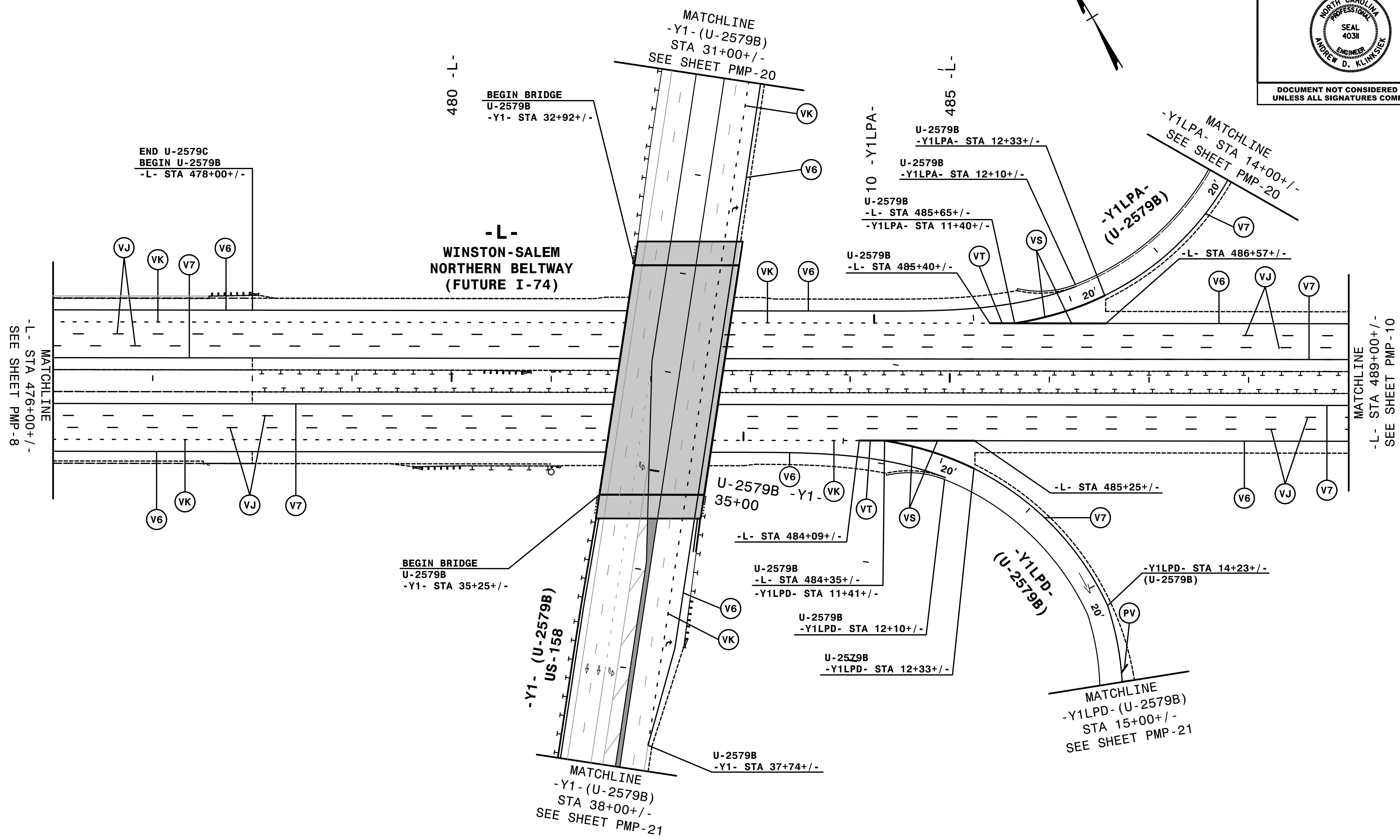

NOTE: ALL LANE WIDTHS ARE 12' UNLESS OTHERWISE SHOWN.

I:\0643_PMP\U-2579C_pmp_09.dgn
HNTB

HNTB
 HNTB NORTH CAROLINA, P.C.
 343 E. Six Forks Road, Suite 200
 Raleigh, North Carolina 27609
 NC License No: C-1554
 (919) 546-8997

PAVEMENT MARKING DETAIL

TIP NO. U-2579C	SHEET NO. PMP-10
APPROVED: <i>Andrew D. Klinck</i> E3078F8459E44B	
DATE: 7/3/2017	
	
DOCUMENT NOT CONSIDERED FINAL UNLESS ALL SIGNATURES COMPLETED	

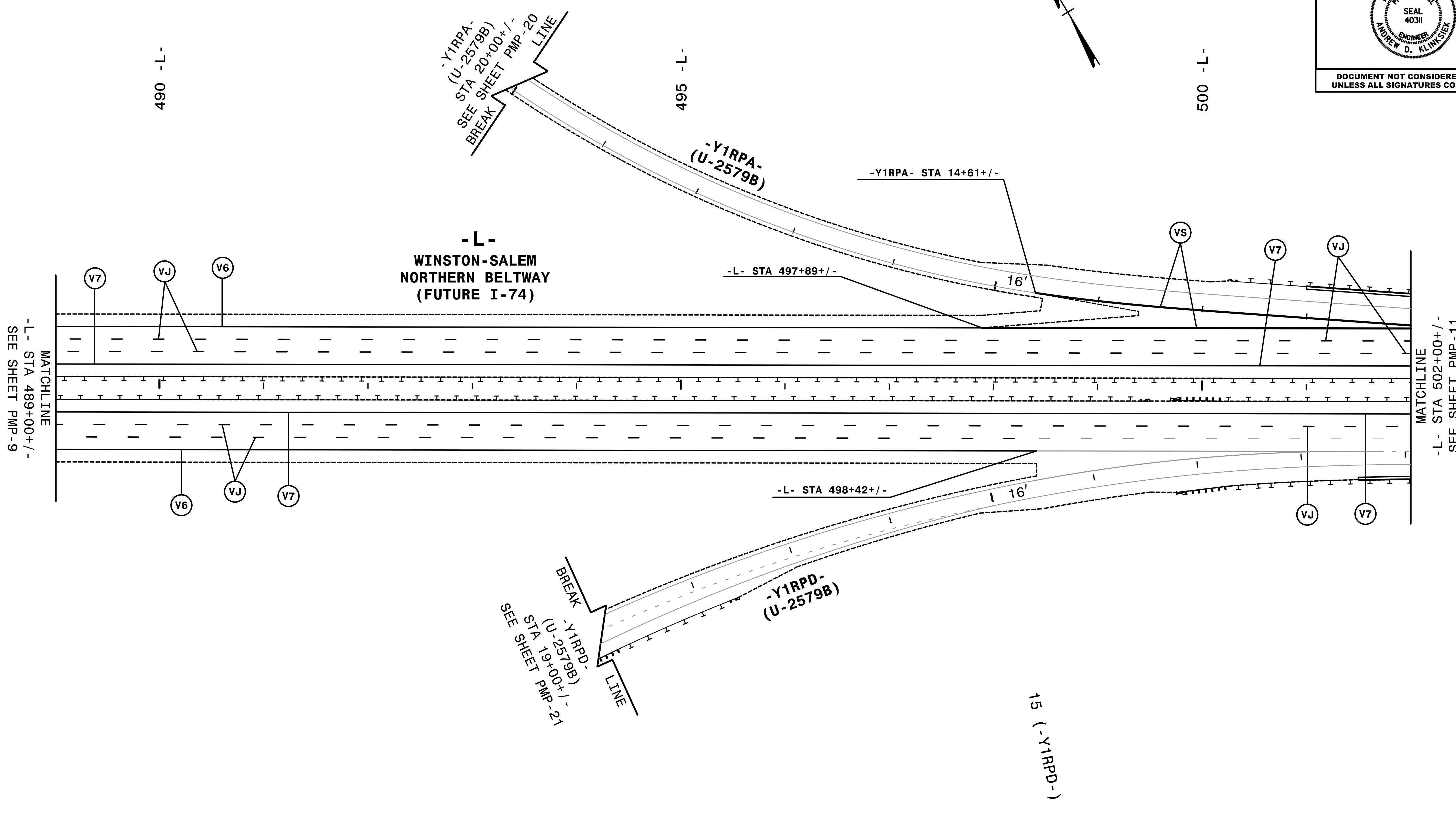

NOTE: ALL LANE WIDTHS ARE 12' UNLESS OTHERWISE SHOWN.

I:\06446_PMP\U-2579C_dmp_pmp_10.dgn
HNTB

HNTB

HNTB NORTH CAROLINA, P.C.
343 E. SIX FORKS ROAD, SUITE 200
RALEIGH, NORTH CAROLINA 27609
NC LICENSE NO: C-1554
(919) 546-8997

PAVEMENT MARKING DETAIL

TIP NO. U-2579C	SHEET NO. PMP-11
APPROVED: <i>Andrew D. Klinck</i> <small>E3078F8459E44B</small>	
DATE: 7/3/2017	
	
DOCUMENT NOT CONSIDERED FINAL UNLESS ALL SIGNATURES COMPLETED	

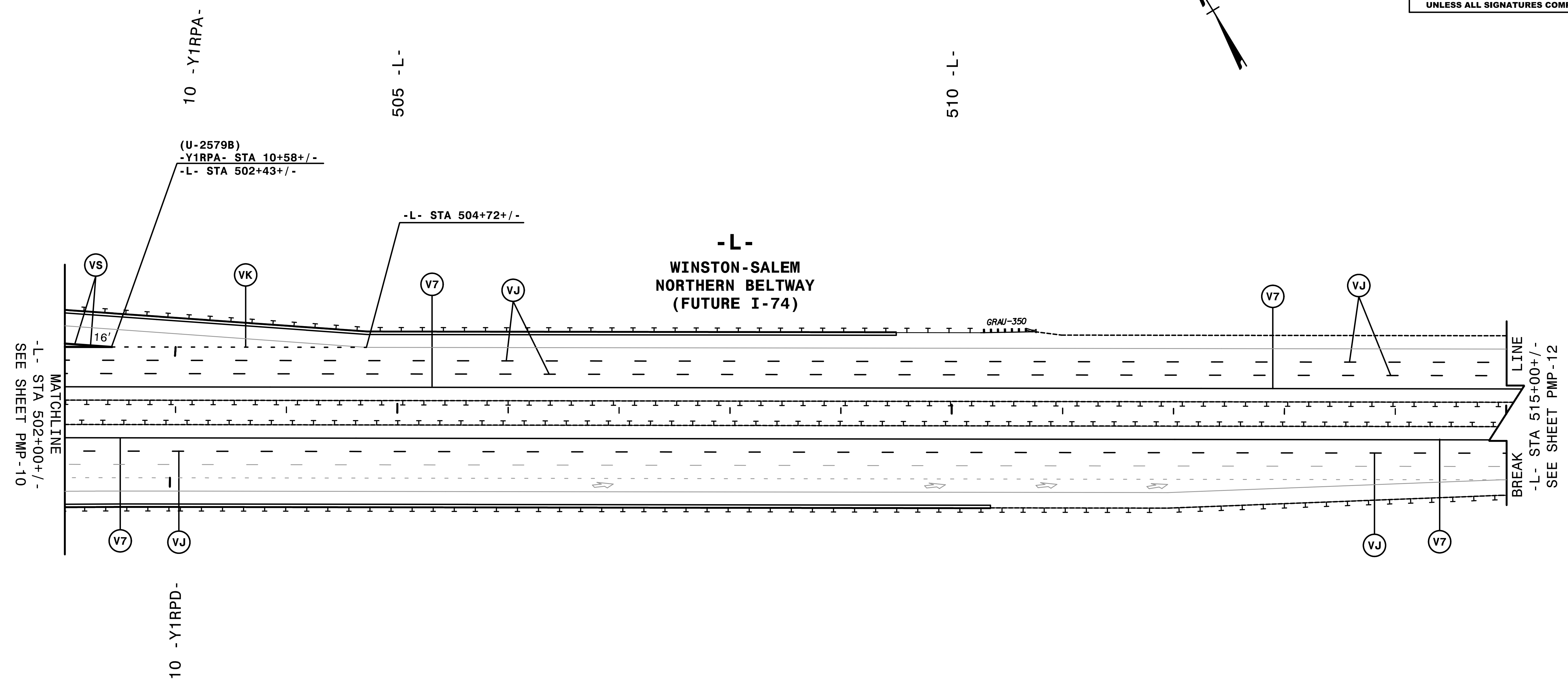

NOTE: ALL LANE WIDTHS ARE 12' UNLESS OTHERWISE SHOWN.

I:\0648_PMP\U-2579C_PMP_11.dgn
HNTB

HNTB HNTB NORTH CAROLINA, P.C.
343 E. SIX FORKS ROAD, SUITE 200
RALEIGH, NORTH CAROLINA 27609
NC LICENSE NO: C-1554
(919) 546-8997

PAVEMENT MARKING DETAIL

TIP NO. U-2579C	SHEET NO. PMP-12
APPROVED: <i>Andrew D. Klinck</i> <small>E3078F84598E44B</small>	
DATE: 7/3/2017	
	
DOCUMENT NOT CONSIDERED FINAL UNLESS ALL SIGNATURES COMPLETED	

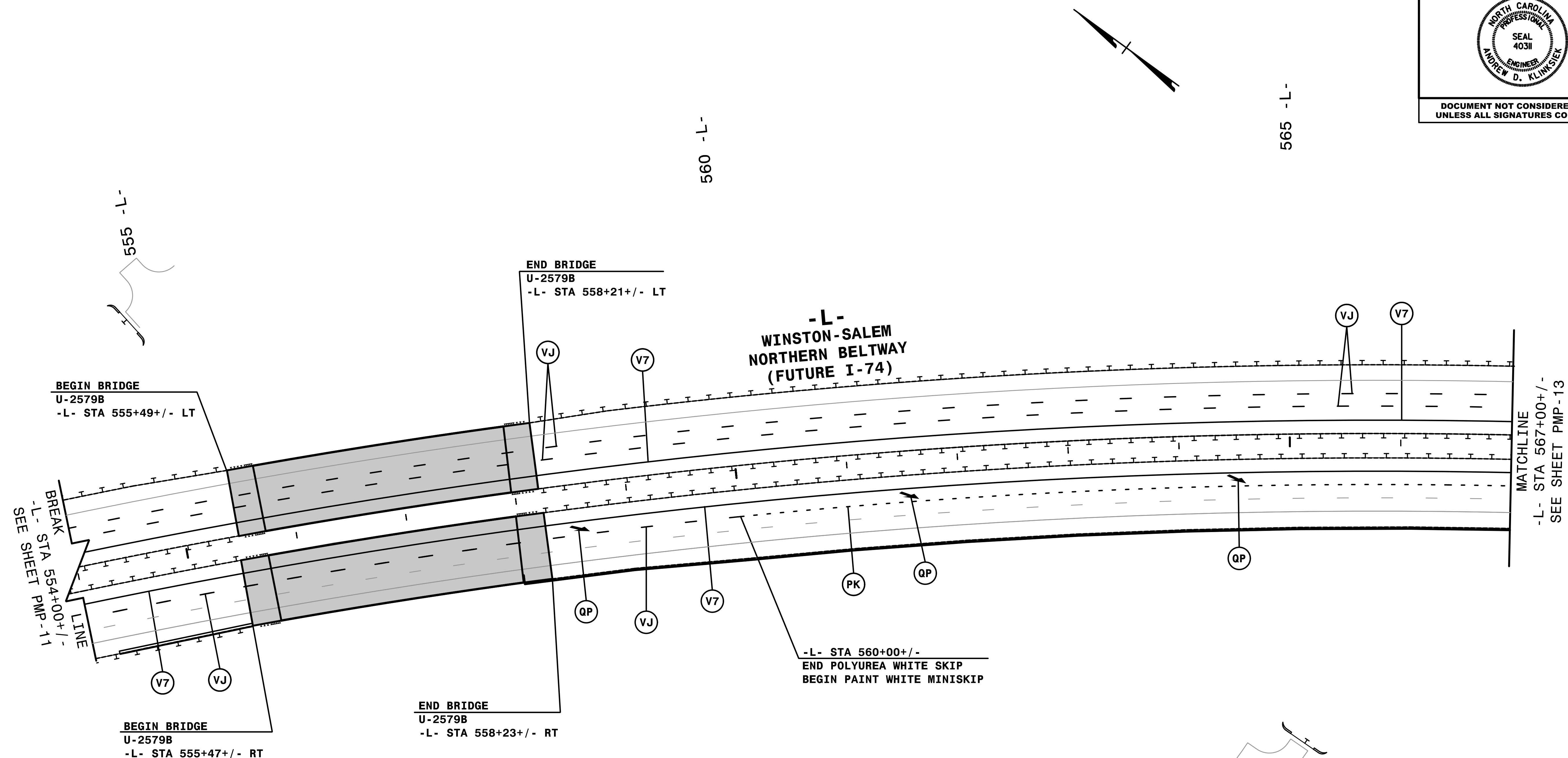

BREAK
-L- STA 554+00+/-
SEE SHEET PMP-11

BEGIN BRIDGE
U-2579B
-L- STA 555+49+/- LT

BEGIN BRIDGE
U-2579B
-L- STA 555+47+/- RT

END BRIDGE
U-2579B
-L- STA 558+23+/- RT

END BRIDGE
U-2579B
-L- STA 558+21+/- LT

-L- WINSTON-SALEM
NORTHERN BELTWAY
(FUTURE I-74)

-L- STA 560+00+/-
END POLYUREA WHITE SKIP
BEGIN PAINT WHITE MINISKIP

MATCHLINE
-L- STA 567+00+/-
SEE SHEET PMP-13

NOTE: ALL LANE WIDTHS ARE 12' UNLESS OTHERWISE SHOWN.

HNTB
HNTB NORTH CAROLINA, P.C.
 343 E. SIX FORKS ROAD, SUITE 200
 RALEIGH, NORTH CAROLINA 27609
 NC LICENSE NO: C-1554
 (919) 546-8997

PAVEMENT MARKING DETAIL

I:\06450_PMP\U-2579C_PMP-12.dgn
 HNTB

TIP NO. U-2579C	SHEET NO. PMP-13
APPROVED: <i>Andrew D. Klinck</i> E3078F84598E44B	
DATE: 7/3/2017	
	
DOCUMENT NOT CONSIDERED FINAL UNLESS ALL SIGNATURES COMPLETED	

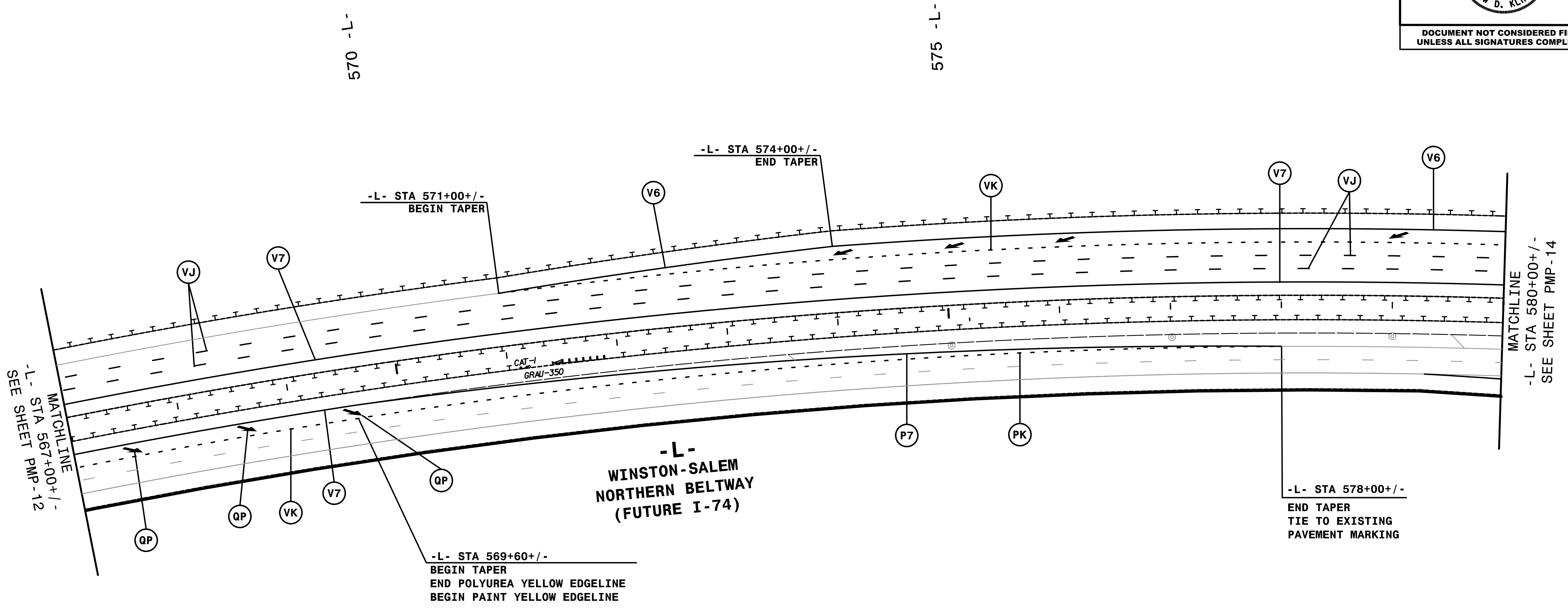

NOTE: ALL LANE WIDTHS ARE 12' UNLESS OTHERWISE SHOWN.

I:\46452_PMP\13\1301\1301_PMP-13.dgn
11/13/17 10:52 AM
HNTB

HNTB
 HNTB NORTH CAROLINA, P.C.
 343 E. SIX FORKS ROAD, SUITE 200
 RALEIGH, NORTH CAROLINA 27609
 NC License No: C-1554
 (919) 546-8997

PAVEMENT MARKING DETAIL

TIP NO. U-2579C	SHEET NO. PMP-14
APPROVED: <i>Andrew D. Klinck</i> E3078F8459E44B	
DATE: 7/3/2017	
SEAL	
	
DOCUMENT NOT CONSIDERED FINAL UNLESS ALL SIGNATURES COMPLETED	

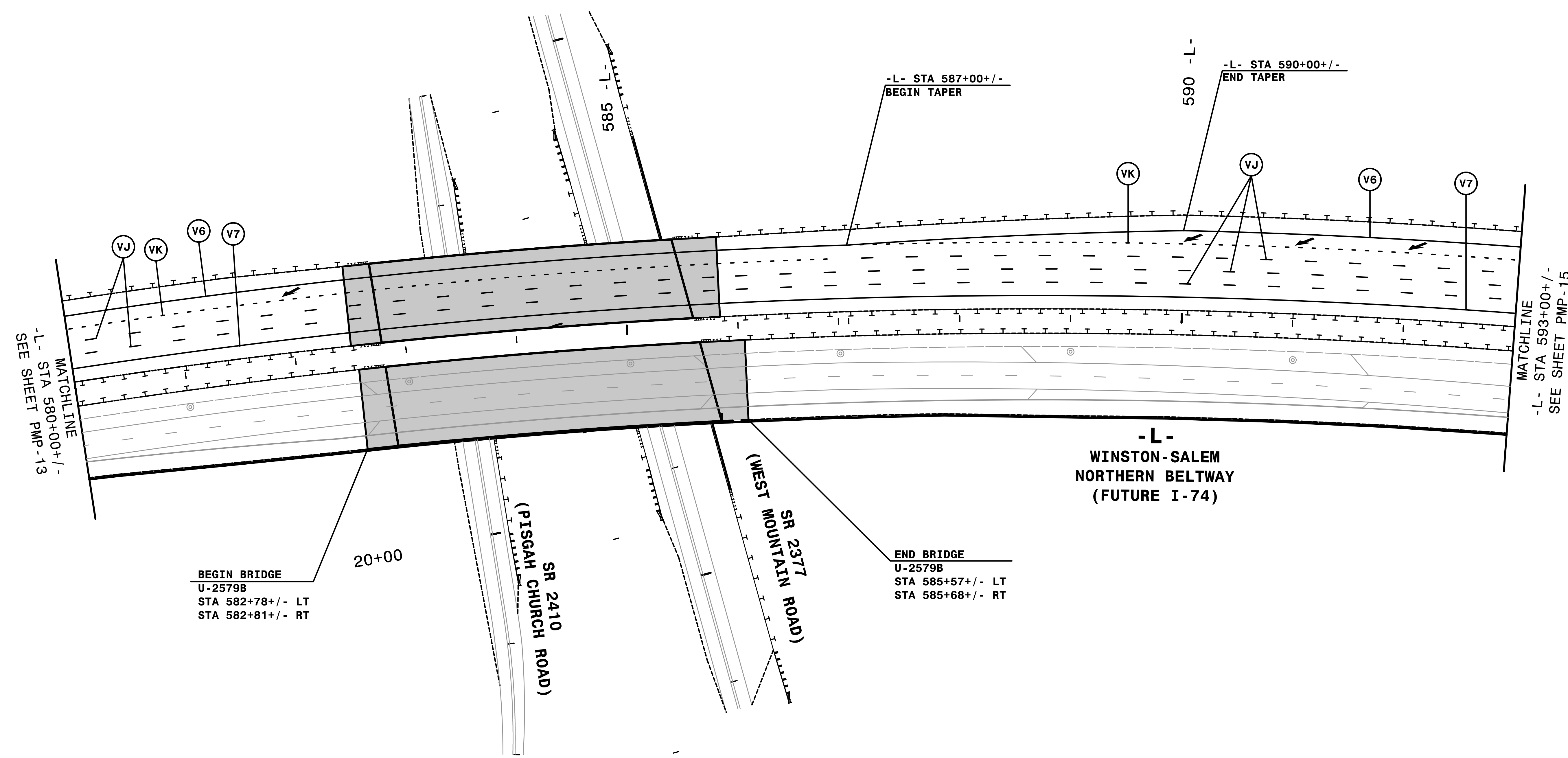

NOTE: ALL LANE WIDTHS ARE 12' UNLESS OTHERWISE SHOWN.

HNTB
 HNTB NORTH CAROLINA, P.C.
 343 E. SIX FORKS ROAD, SUITE 200
 RALEIGH, NORTH CAROLINA 27609
 NC LICENSE NO: C-1554
 (919) 546-8997

PAVEMENT MARKING DETAIL

I:\06544.PM
V:\PMP\U-2579C.dmp_PMP_14.dgn
HNTB

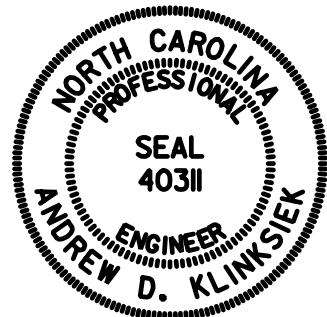
TIP NO. U-2579C	SHEET NO. PMP-15
APPROVED: <i>Andrew D. Klinck</i> <small>E3078F8459E44B</small>	
DATE: 7/3/2017	
	
DOCUMENT NOT CONSIDERED FINAL UNLESS ALL SIGNATURES COMPLETED	

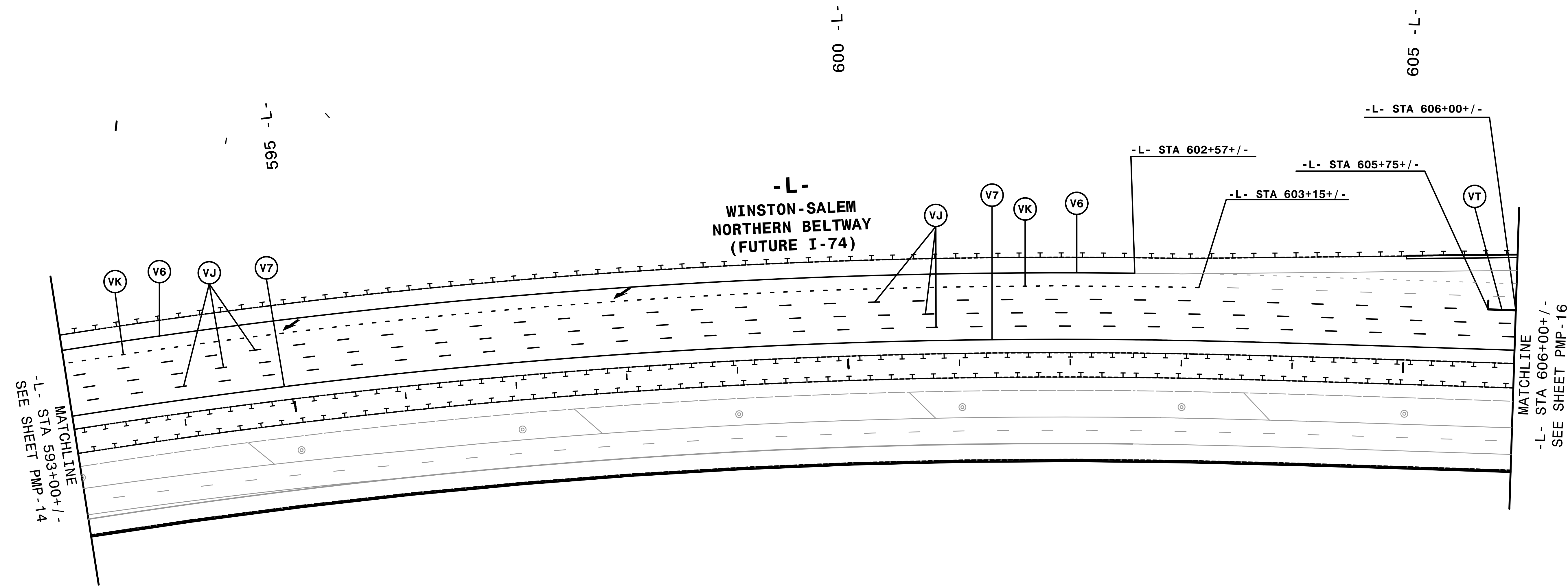

NOTE: ALL LANE WIDTHS ARE 12' UNLESS OTHERWISE SHOWN.

HNTB
HNTB NORTH CAROLINA, P.C.
 343 E. Six Forks Road, Suite 200
 Raleigh, North Carolina 27609
 NC License No: C-1554
 (919) 546-8997

PAVEMENT MARKING DETAIL

I:\06456 PM
V\PM\U-2579C_dmp_pmp_15.dgn
HNTB

TIP NO. U-2579C	SHEET NO. PMP-16
APPROVED: <i>Andrew D. Klinck</i> <small>E3078F84598E44B</small>	
DATE: 7/3/2017	
SEAL	
	
DOCUMENT NOT CONSIDERED FINAL UNLESS ALL SIGNATURES COMPLETED	

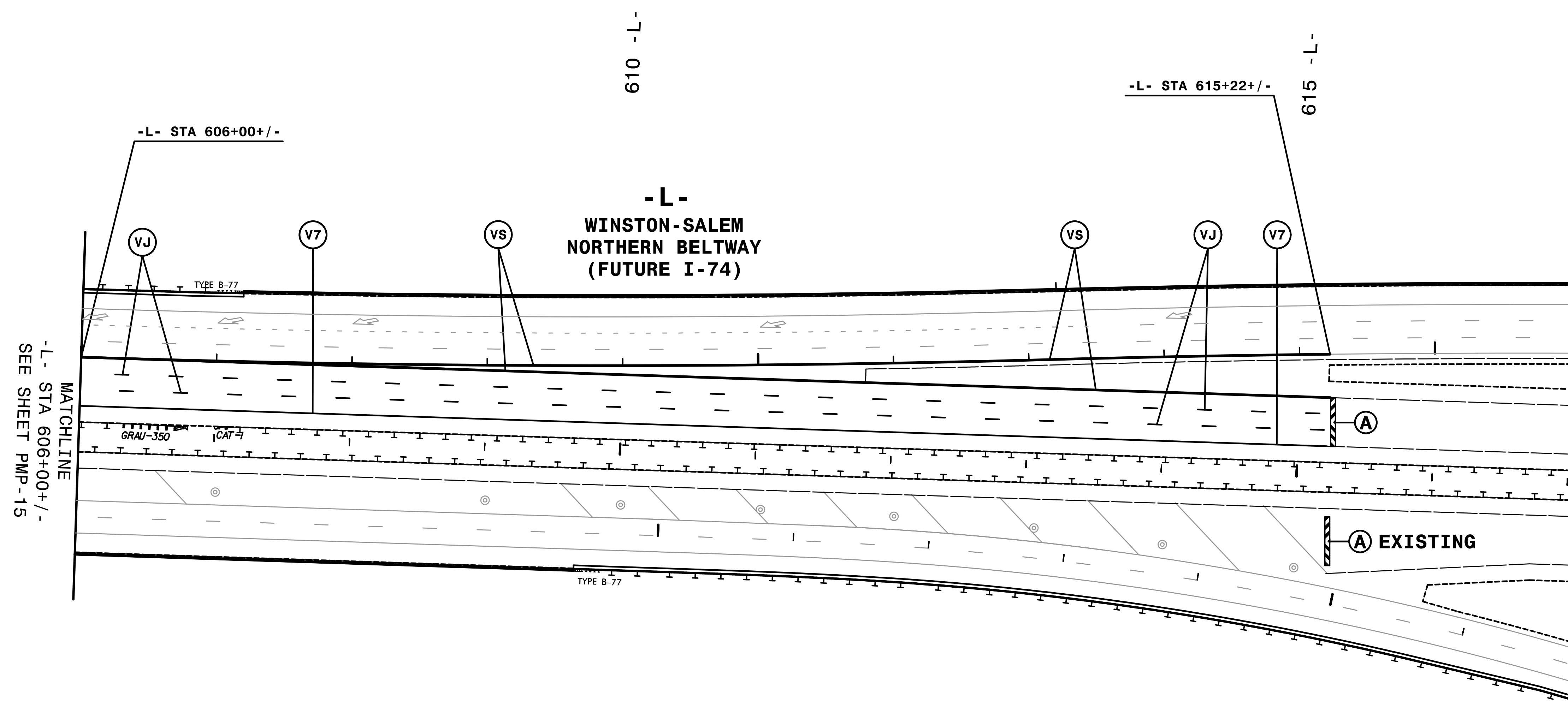

MATCHLINE
 -L- STA 606+00+/-
 SEE SHEET PMP-15

NOTE: ALL LANE WIDTHS ARE 12' UNLESS OTHERWISE SHOWN.

I:\06459_PMP\U-2579C_PMP_16.dgn
 HNTB

HNTB
 HNTB NORTH CAROLINA, P.C.
 343 E. SIX FORKS ROAD, SUITE 200
 RALEIGH, NORTH CAROLINA 27609
 NC LICENSE NO: C-1554
 (919) 546-8997

PAVEMENT MARKING DETAIL

TIP NO. U-2579C	SHEET NO. PMP-17
APPROVED: <i>Andrew D. Klinck</i> E3078F8459E44B	
DATE: 7/3/2017	
SEAL 	
DOCUMENT NOT CONSIDERED FINAL UNLESS ALL SIGNATURES COMPLETED	

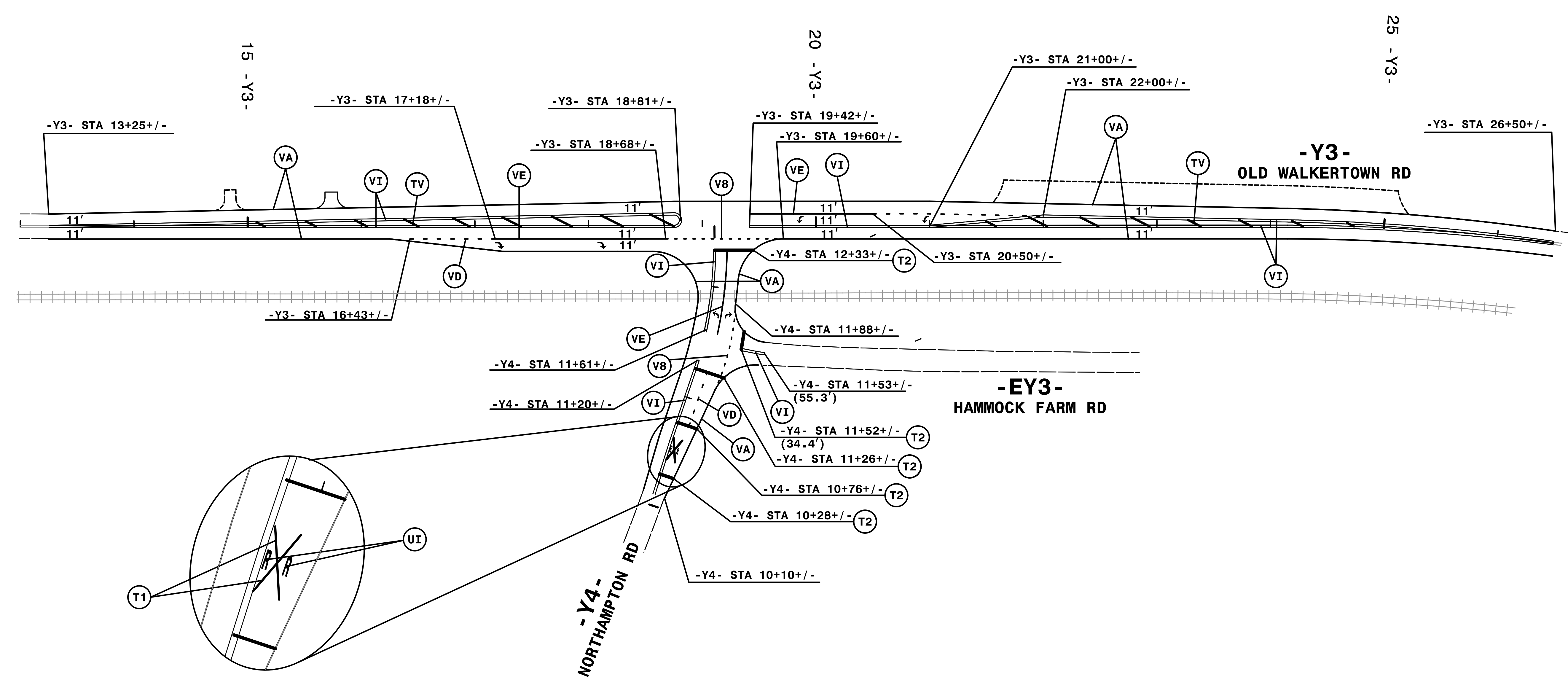

NOTE: ALL LANE WIDTHS ARE 12' UNLESS OTHERWISE SHOWN.

I:\47403_PMP\U-2579C_PMP_17.dgn
HNTB

HNTB
 HNTB NORTH CAROLINA, P.C.
 343 E. SIX FORKS ROAD, SUITE 200
 RALEIGH, NORTH CAROLINA 27609
 NC LICENSE NO: C-1554
 (919) 546-8997

PAVEMENT MARKING DETAIL

TIP NO. U-2579C	SHEET NO. PMP-18
APPROVED: <i>Andrew D. Klinck</i> E3078F8459E44B	
DATE: 7/3/2017	
	
DOCUMENT NOT CONSIDERED FINAL UNLESS ALL SIGNATURES COMPLETED	

(A) TYPE III BARRICADES WILL REMAIN IN PLACE AT THE COMPLETION OF THE PROJECT. SEE SPECIAL PROVISIONS

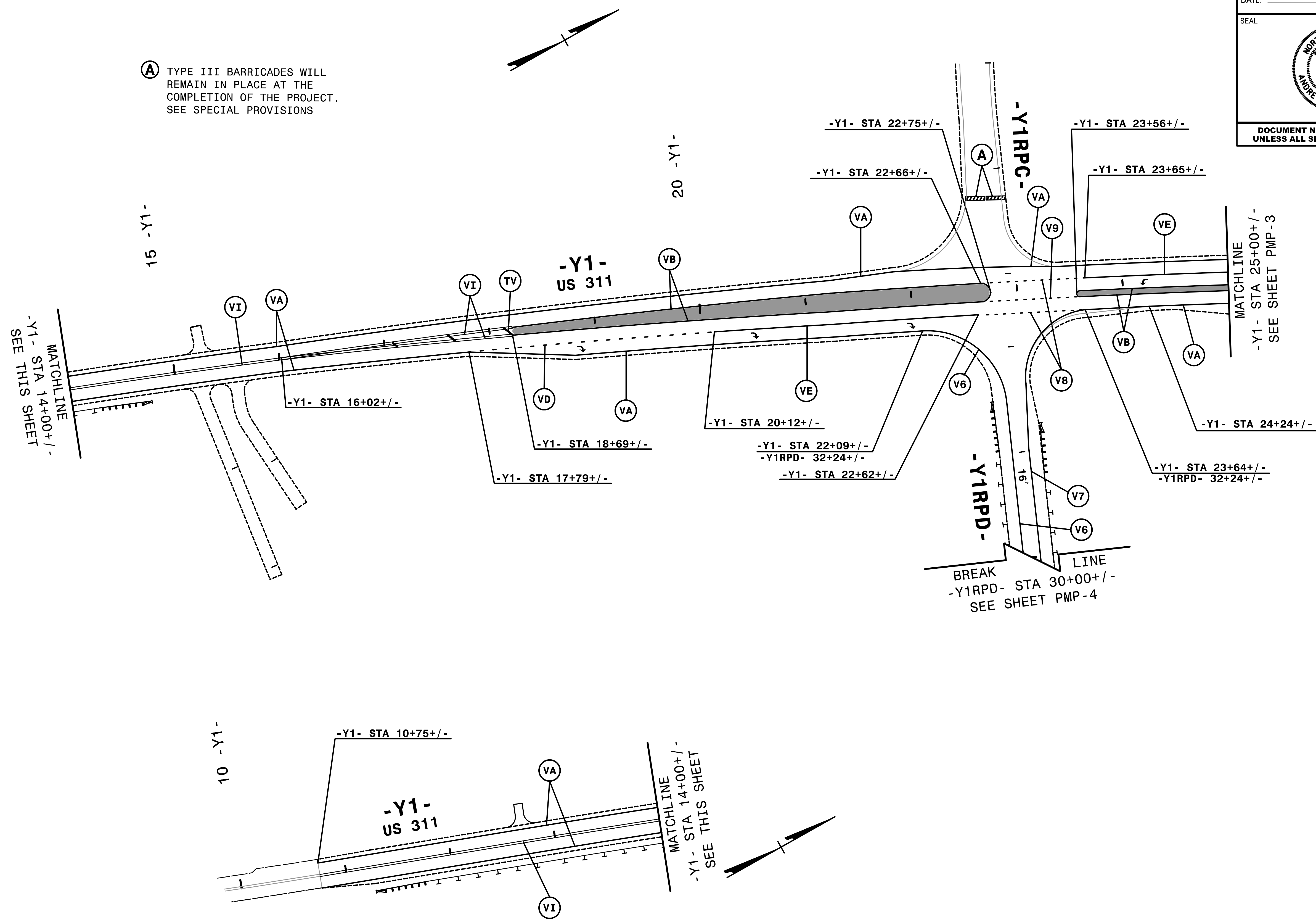

NOTE: ALL LANE WIDTHS ARE 12' UNLESS OTHERWISE SHOWN.

I:\47406_PMP\U-2579C_PMP-18.dgn
 HNTB

HNTB HNTB NORTH CAROLINA, P.C.
 343 E. Six Forks Road, Suite 200
 Raleigh, North Carolina 27609
 NC License No: C-1554
 (919) 546-8997

PAVEMENT MARKING DETAIL

TIP NO. U-2579C	SHEET NO. PMP-19
APPROVED: <i>Andrew D. Klinck</i> E3078F84598E44B	
DATE: 7/3/2017	
SEAL 	
DOCUMENT NOT CONSIDERED FINAL UNLESS ALL SIGNATURES COMPLETED	

(A) TYPE III BARRICADES WILL REMAIN IN PLACE AT THE COMPLETION OF THE PROJECT. SEE SPECIAL PROVISIONS

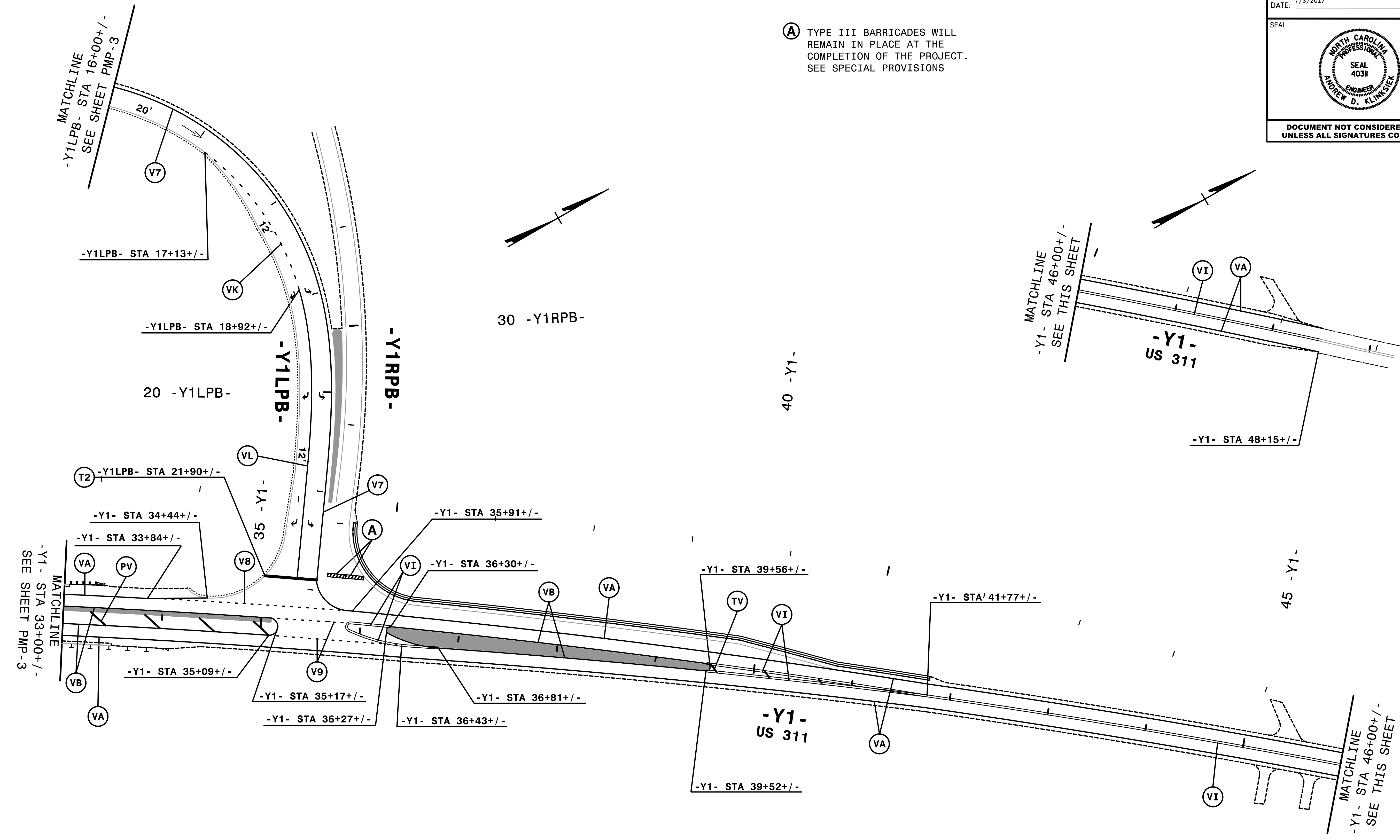

NOTE: ALL LANE WIDTHS ARE 12' UNLESS OTHERWISE SHOWN.

I:\47409_PMP\U-2579C_PMP_19.dgn
HNTB

HNTB
HNTB NORTH CAROLINA, P.C.
343 E. SIX FORKS ROAD, SUITE 200
RALEIGH, NORTH CAROLINA 27609
NC LICENSE NO: C-1554
(919) 546-8997

PAVEMENT MARKING DETAIL

TIP NO. U-2579C	SHEET NO. PMP-20
APPROVED: <i>Andrew D. Klinck</i> E3078F8459E44B	
DATE: 7/3/2017	
SEAL	
	
DOCUMENT NOT CONSIDERED FINAL UNLESS ALL SIGNATURES COMPLETED	

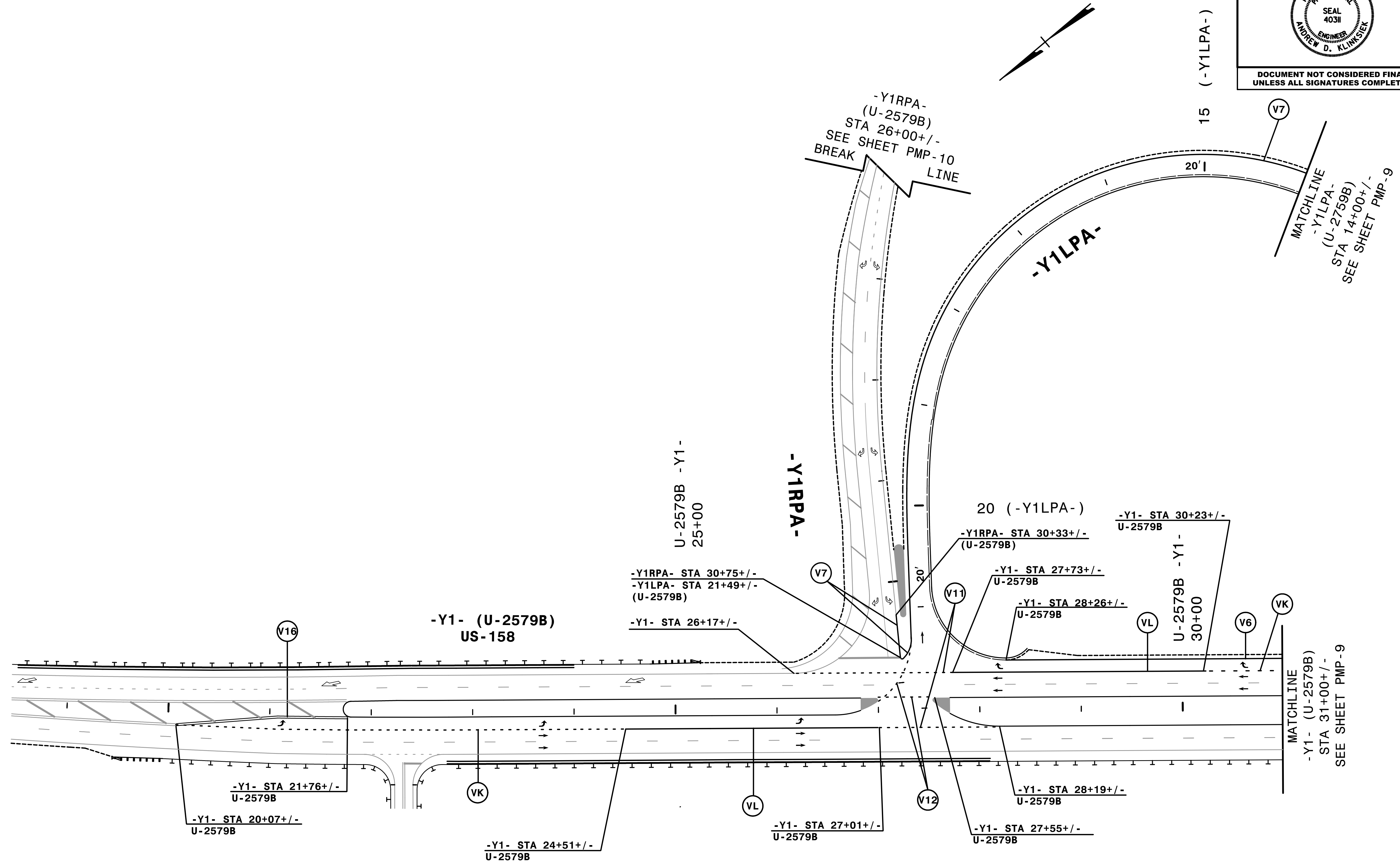

NOTE: ALL LANE WIDTHS ARE 12' UNLESS OTHERWISE SHOWN.

HNTB
 HNTB NORTH CAROLINA, P.C.
 343 E. Six Forks Road, Suite 200
 Raleigh, North Carolina 27609
 NC License No: C-1554
 (919) 546-8997

PAVEMENT MARKING DETAIL

I:\4741\PM
U-2579C.dmp_PMP_20.dgn
HNTB

TIP NO. U-2579C	SHEET NO. PMP-21
APPROVED: <i>Andrew D. Klinck</i> <small>E3078F8459E44B</small>	
DATE: 7/3/2017	
SEAL 	
DOCUMENT NOT CONSIDERED FINAL UNLESS ALL SIGNATURES COMPLETED	

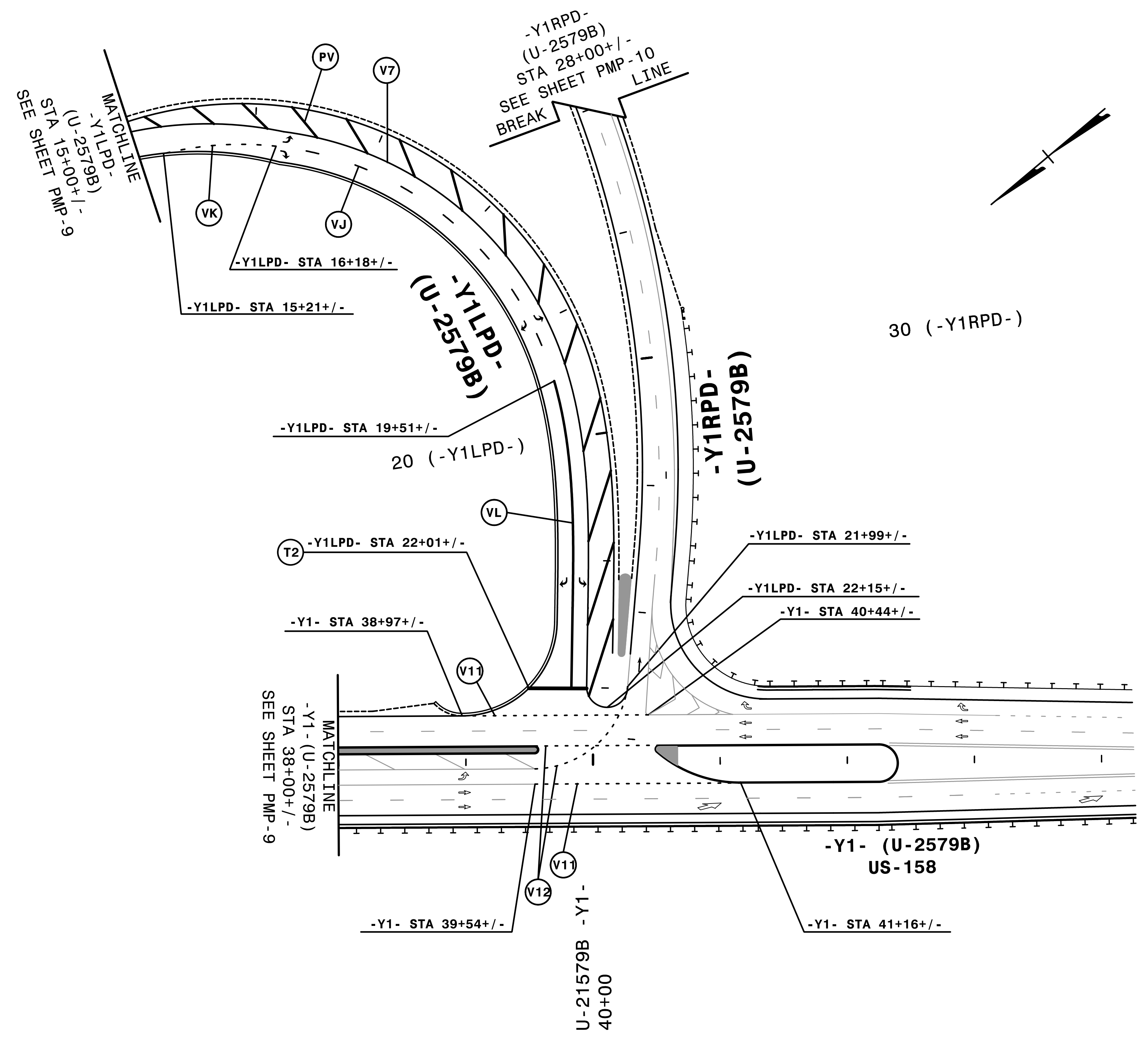

NOTE: ALL LANE WIDTHS ARE 12' UNLESS OTHERWISE SHOWN.

HNTB
HNTB NORTH CAROLINA, P.C.
343 E. Six Forks Road, Suite 200
Raleigh, North Carolina 27609
NC License No: C-1554
(919) 546-8997

PAVEMENT MARKING DETAIL

I:\4743_PM
U-2579C_PMP-21.dgn
HNTB

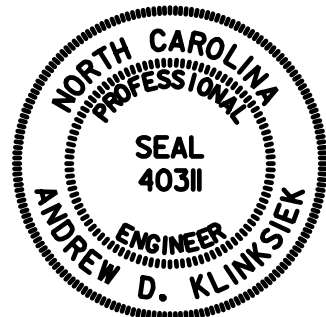
TIP NO. U-2579C	SHEET NO. PMP-22
APPROVED: <i>Andrew D. Klinck</i> <small>E3078F8459E44B</small>	
DATE: 7/3/2017	
SEAL 	
DOCUMENT NOT CONSIDERED FINAL UNLESS ALL SIGNATURES COMPLETED	

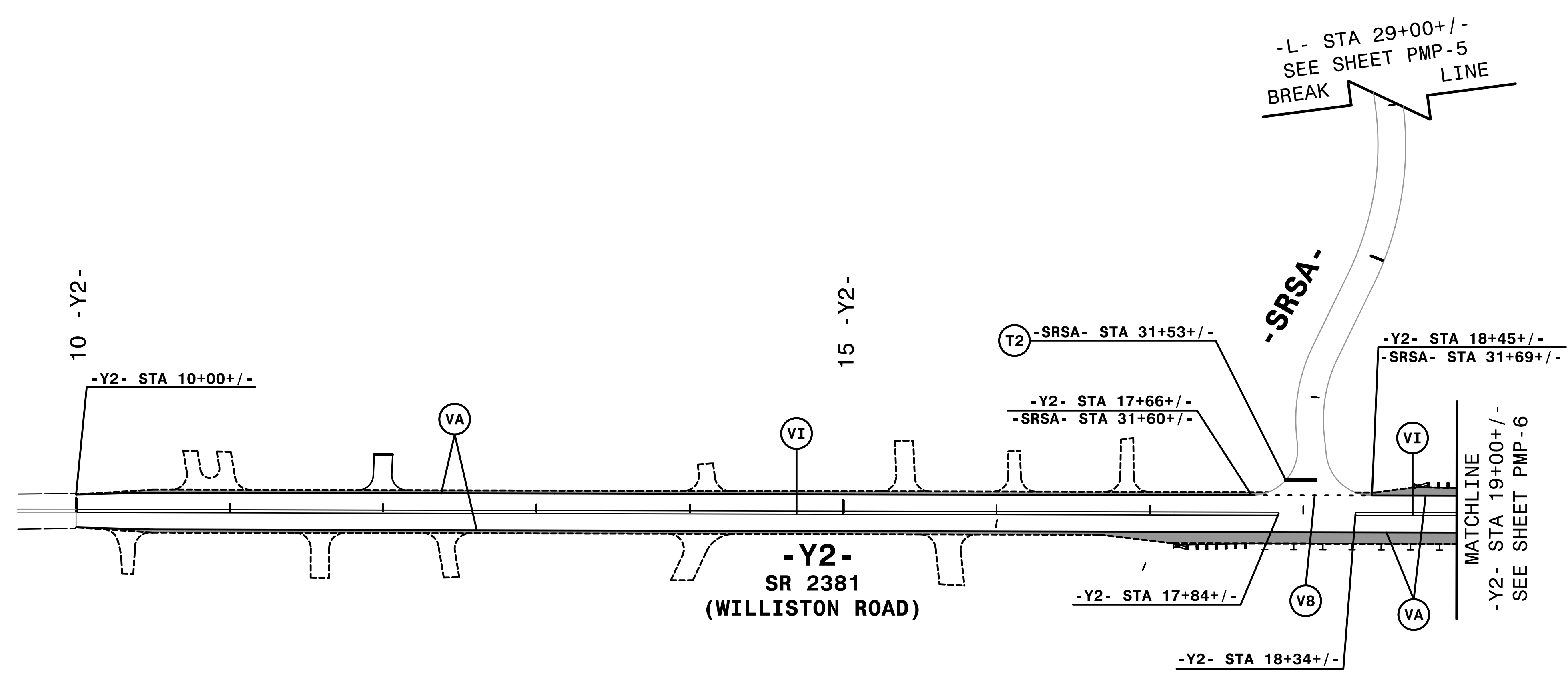

NOTE: ALL LANE WIDTHS ARE 12' UNLESS OTHERWISE SHOWN.

I:\1745_PM
PMP\U-2579C_dmp_PMP_22.dgn
HNTB

HNTB
 HNTB NORTH CAROLINA, P.C.
 343 E. SIX FORKS ROAD, SUITE 200
 RALEIGH, NORTH CAROLINA 27609
 NC LICENSE NO: C-1554
 (919) 546-8997

PAVEMENT MARKING DETAIL