

**This electronic collection of documents is provided  
for the convenience of the user  
and is Not a Certified Document –**

**The documents contained herein were originally issued  
and sealed by the individuals whose names and license  
numbers appear on each page, on the dates appearing  
with their signature on that page.**

**This file or an individual page  
shall not be considered a certified document.**

**T.I.P.: B-5362**

**CONTRACT: C203976**

**STATE OF NORTH CAROLINA  
DEPARTMENT OF TRANSPORTATION**

**PAVEMENT MARKING PLAN  
MONTGOMERY / MOORE COUNTIES  
LOCATION: BRIDGE NO. 53 OVER DROWNING CREEK  
ON NC 73**

<small>PROJECT REFERENCE NO.</small> <b>B-5362</b>	<small>SHEET NO.</small> <b>PMP - 1</b>
<small>Drawn/Designed by:</small> <i>Renee Roach</i>	
<small>APPROVED:</small> <i>Renee Roach</i>	
<small>DATE:</small> 7/26/2017   12:50 PM EDT	
<small>SEAL</small>	
	

**ROADWAY STANDARD DRAWING**

THE FOLLOWING ROADWAY STANDARDS AS APPEAR IN "ROADWAY STANDARD DRAWINGS" - PROJECT SERVICES UNIT - N.C. DEPARTMENT OF TRANSPORTATION - RALEIGH, N.C., DATED JANUARY 2012 ARE APPLICABLE TO THIS PROJECT AND BY REFERENCE HEREBY ARE CONSIDERED A PART OF THESE PLANS:

<u>STD. NO.</u>	<u>TITLE</u>
1205.01	PAVEMENT MARKINGS - LINE TYPES AND OFFSETS
1205.02	PAVEMENT MARKINGS - TWO-LANE AND MULTILANE ROADWAYS
1205.12	PAVEMENT MARKINGS - BRIDGES
1250.01	RAISED PAVEMENT MARKERS - INSTALLATION SPACING
1251.01	RAISED PAVEMENT MARKERS - PERMANENT AND TEMPORARY
1261.01	GUARDRAIL AND BARRIER DELINEATORS - INSTALLATION SPACING
1261.02	GUARDRAIL AND BARRIER DELINEATORS - TYPES AND MOUNTING
1262.01	GUARDRAIL END DELINEATION

**GENERAL NOTES**

THE FOLLOWING GENERAL NOTES APPLY AT ALL TIMES FOR THE DURATION OF THE CONSTRUCTION PROJECT, EXCEPT WHEN OTHERWISE NOTED IN THE PLAN, OR DIRECTED BY THE ENGINEER.

- A) INSTALL PAVEMENT MARKINGS AND PAVEMENT MARKERS ON THE FINAL SURFACE AS FOLLOWS:
 

<small>ROAD NAME</small>	<small>MARKING</small>	<small>MARKER</small>
NC 73	THERMOPLASTIC	RAISED
- B) TIE PROPOSED PAVEMENT MARKING LINES TO EXISTING PAVEMENT MARKING LINES.
- C) REMOVE/REPLACE ANY CONFLICTING/DAMAGED PAVEMENT MARKINGS AND MARKERS.
- D) PASSING ZONES WILL BE DETERMINED IN THE FIELD AND MUST BE APPROVED BY THE ENGINEER

**INDEX**

<u>SHEET NO.</u>	<u>DESCRIPTION</u>
PMP-1	PAVEMENT MARKING PLAN TITLE SHEET
PMP-2	PAVEMENT MARKING DETAIL

**PAVEMENT MARKING SCHEDULE**

<u>SYMBOL</u>	<u>DESCRIPTION</u>
	THERMO (4", 120 MILS)
TI	YELLOW DOUBLE CENTER
	THERMO (4", 90 MILS)
TA	WHITE EDGELINE
	PERMANENT RAISED PAVEMENT MARKERS
MA	YELLOW & YELLOW

PLAN PREPARED BY: N.C.D.O.T. SIGNING AND DELINEATION UNIT

K. L. JORDAN \_\_\_\_\_ SIGNING & DELINEATION REGIONAL ENGINEER  
 A. K. MATTHEWS \_\_\_\_\_ SIGNING & DELINEATION PROJECT DESIGN ENGINEER/TECHNICIAN

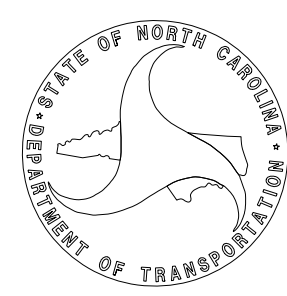

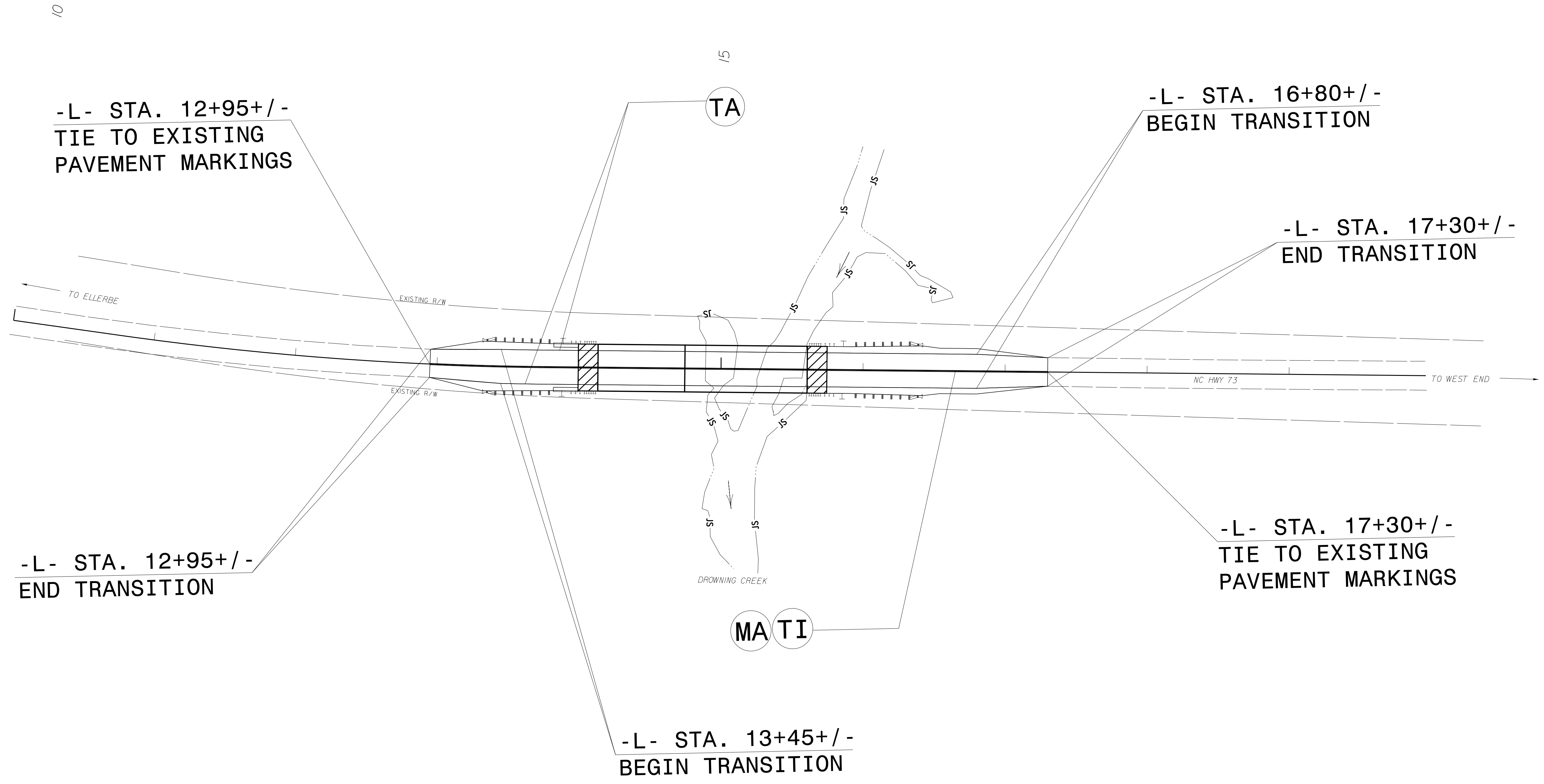
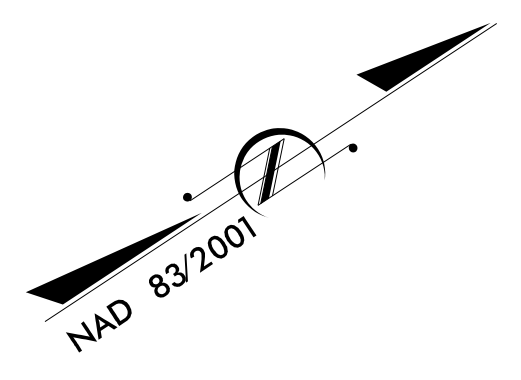

07/26/17  
 P:\TIP-Projects-B\B5362\Traffic\Signing\CADD\Pavement Marking Plans\B-5362 Pavement Marking Seed .dgn  
 User: rknolthens

**PAVEMENT MARKING  
DETAIL**