

**This electronic collection of documents is provided
for the convenience of the user
and is Not a Certified Document –**

**The documents contained herein were originally issued
and sealed by the individuals whose names and license
numbers appear on each page, on the dates appearing
with their signature on that page.**

**This file or an individual page
shall not be considered a certified document.**

TIP PROJECT: U-2579C

CONTRACT: C203979

STATE OF NORTH CAROLINA
DIVISION OF HIGHWAYS

FORSYTH COUNTY

**LOCATION: WINSTON - SALEM NORTHERN BELTWAY (EASTERN SECTION)
FROM US 311 TO US 158 (FUTURE I-74)**

**TYPE OF WORK: WIDENING, GRADING, PAVING, DRAINAGE, SIGNING, SIGNALS,
ITS, CULVERTS AND STRUCTURES.**

STATE	STATE PROJECT REFERENCE NO.	SHEET NO.	TOTAL SHEETS
N.C.	U-2579C		
STATE PROJ. NO.	F.A. PROJ. NO.	DESCRIPTION	
34839.1.9	NA	PE	
34839.2.6	NA	RW	
34839.2.GV18	NA	RW	
34839.2.16	NA	UTIL	
34839.3.GV6	NHP-0918(062)	CONSTR.	

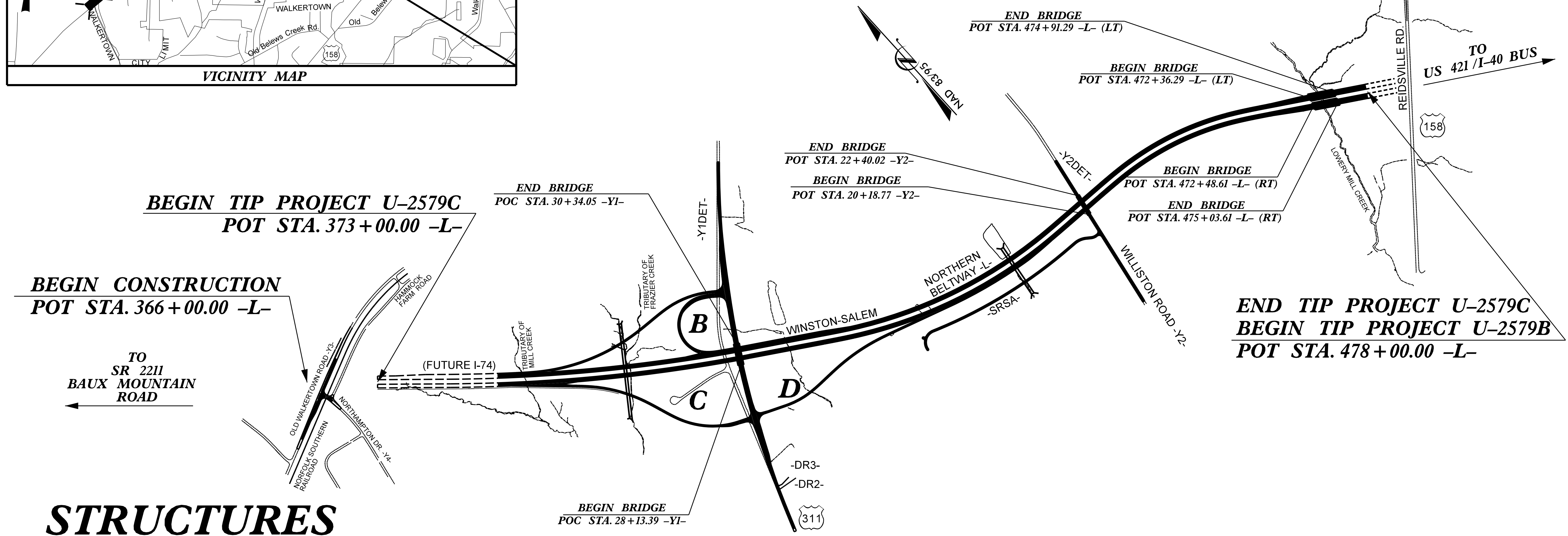
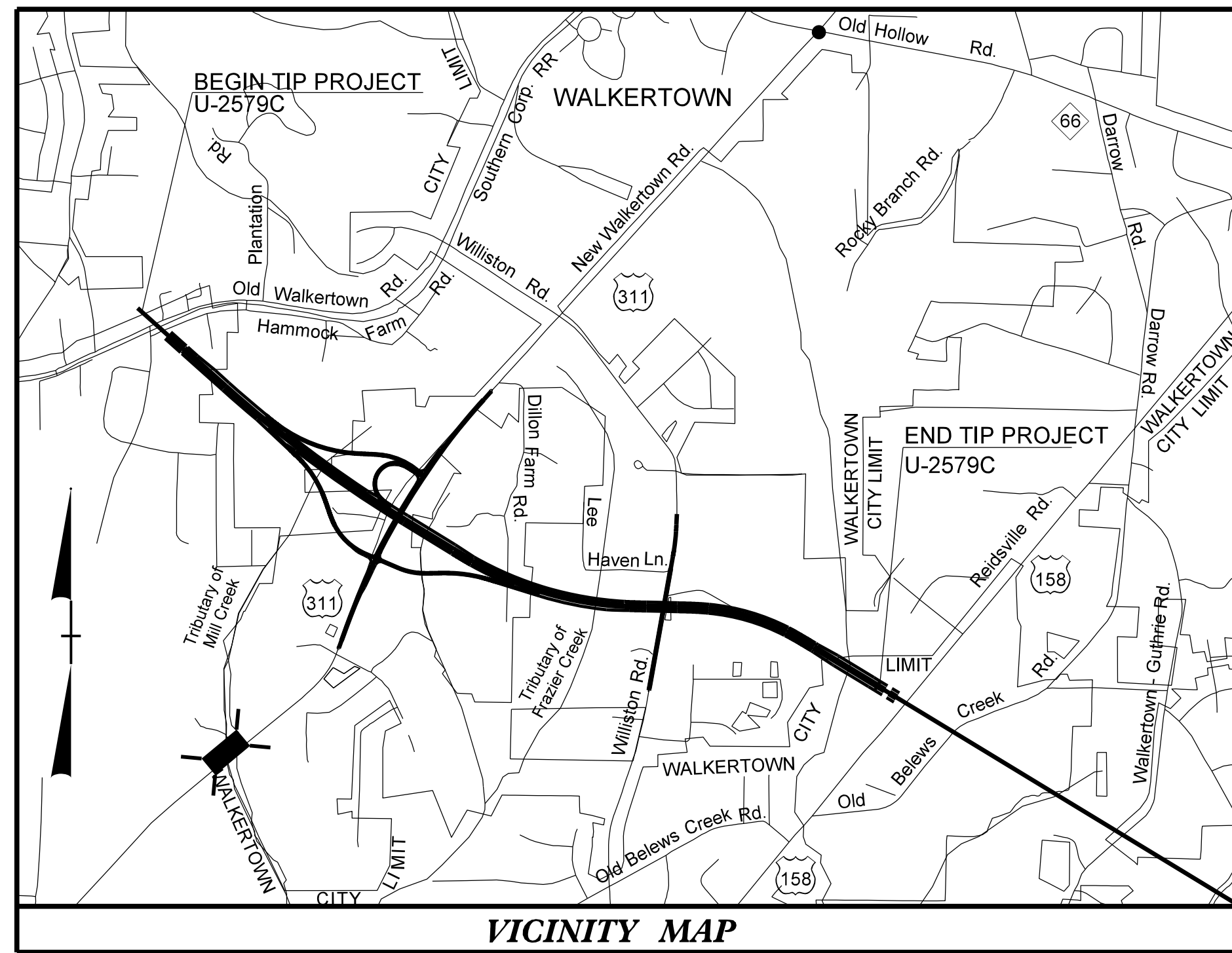
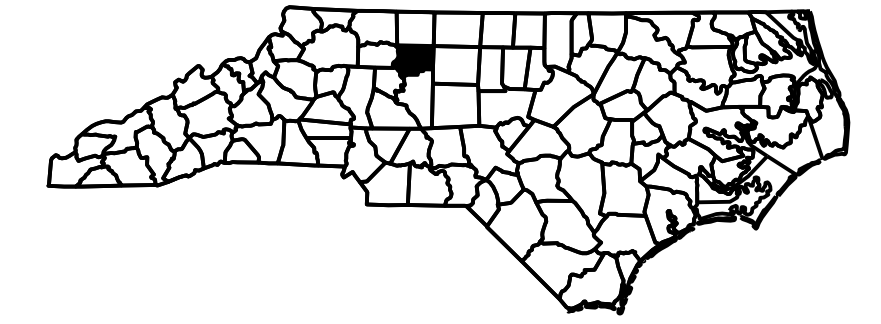

STRUCTURES

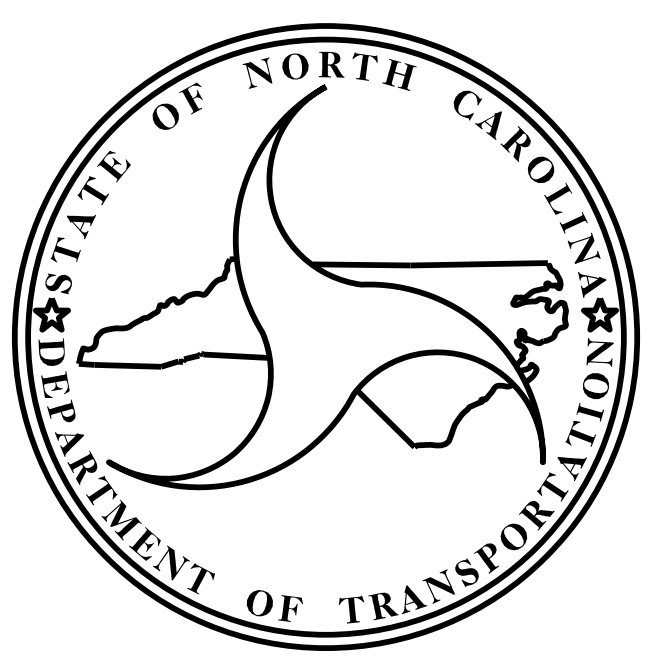

DESIGN DATA

ADT 2017 =	65,592
ADT 2037 =	93,112
DHV =	10 %
D =	60 %
T =	18 % *
V =	70 MPH

* TTST 12 % DUAL 6 %

PROJECT LENGTH

LENGTH OF ROADWAY PROJECT U-2579C	= 1.941 Miles
LENGTH OF STRUCTURE PROJECT U-2579C	= 0.048 Mile
TOTAL LENGTH OF TIP PROJECT U-2579C	= 1.989 Miles

Prepared in the Office of:
DIVISION OF HIGHWAYS
STRUCTURES MANAGEMENT UNIT
1000 BIRCH RIDGE DR.
RALEIGH, N.C. 27610

2012 STANDARD SPECIFICATIONS

LETTING DATE :
OCTOBER 17, 2017

A. KEITH PASCHAL, P.E.
PROJECT ENGINEER

MARC G. CHEEK, P.E.
PROJECT DESIGN ENGINEER

BEGIN TIP PROJECT U-2579C
POT STA. 373+00.00 -L-

BEGIN CONSTRUCTION
POT STA. 366+00.00 -L-

TO
 SR 2211
 BAUX MOUNTAIN
 ROAD

END TIP PROJECT U-2579C
BEGIN TIP PROJECT U-2579B
POT STA. 478+00.00 -L-

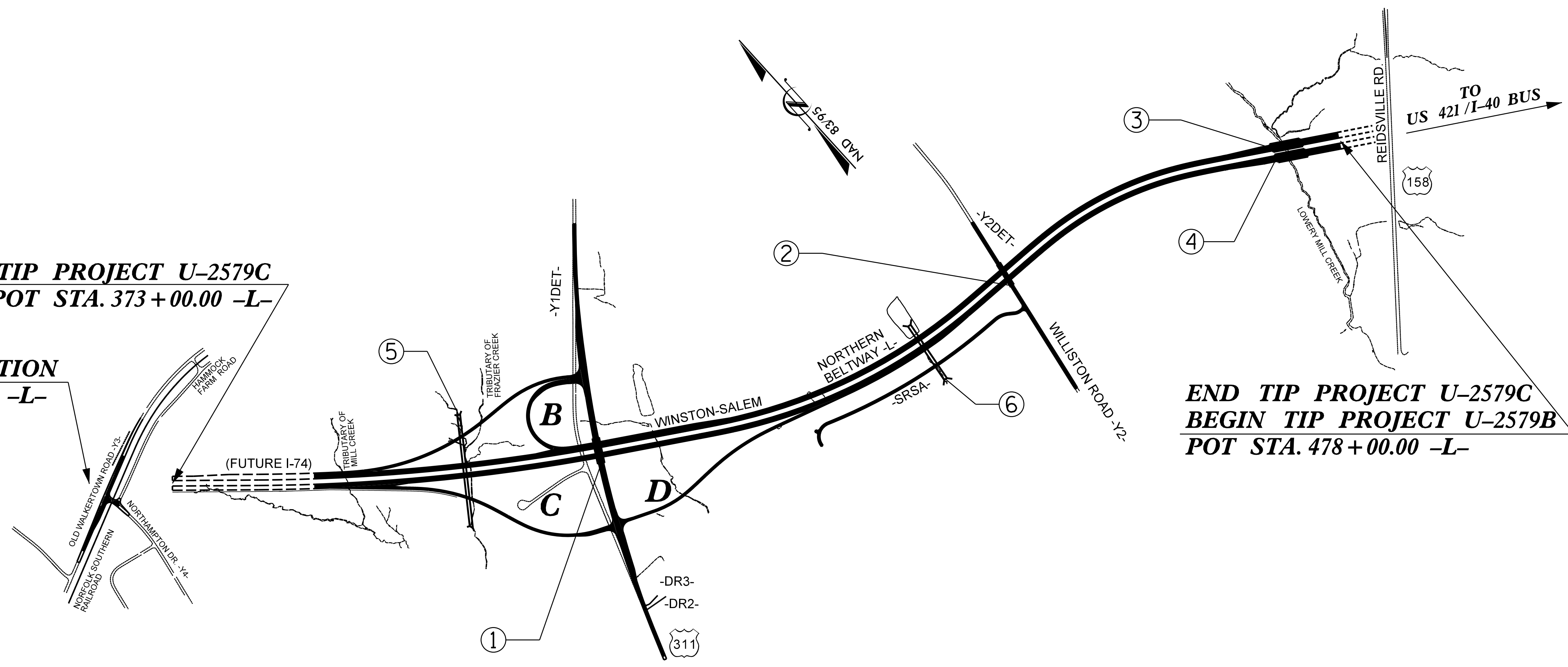

INDEX			
STR. No.	STATION	DESCRIPTION	SHEETS
1	409+03.84 -L- 29+24.97 -Y1-	BRIDGE OVER WINSTON-SALEM NORTHERN BELTWAY ON US 311 BETWEEN SR 2393 AND SR 2381	S1-1 THRU S1-32
2	447+07.91 -L- 21+27.27 -Y2-	BRIDGE OVER WINSTON-SALEM NORTHERN BELTWAY ON SR 2381 BETWEEN SR 2396 AND US 311	S2-1 THRU S2-30
3	473+70.00 -L-	LEFT LANE BRIDGE OVER LOWERY MILL CREEK ON WINSTON-SALEM BELTWAY BETWEEN SR 2381 AND US 158	S3-1 THRU S3-33
4	473+70.00 -L-	RIGHT LANE BRIDGE OVER LOWERY MILL CREEK ON WINSTON-SALEM BELTWAY BETWEEN SR 2381 AND US 158	S4-1 THRU S4-33
5	397+73.00 -L-	SINGLE 6 FT. X 7 FT. RCBC	C1-1 THRU C1-5
6	437+96.50 -L-	SINGLE 8 FT. X 8 FT. RCBC	C2-1 THRU C2-5

PROJECT NO. U-2579C
FORSYTH COUNTY

STATE OF NORTH CAROLINA
 DEPARTMENT OF TRANSPORTATION
 RALEIGH

INDEX

REVISIONS						SHEET NO.
NO.	BY:	DATE:	NO.	BY:	DATE:	
1			3			TOTAL SHEETS
2			4			

DRAWN BY : H. T. BARBOUR DATE : 5-9-17
 CHECKED BY : MARC G. CHEEK DATE : 6-17-17

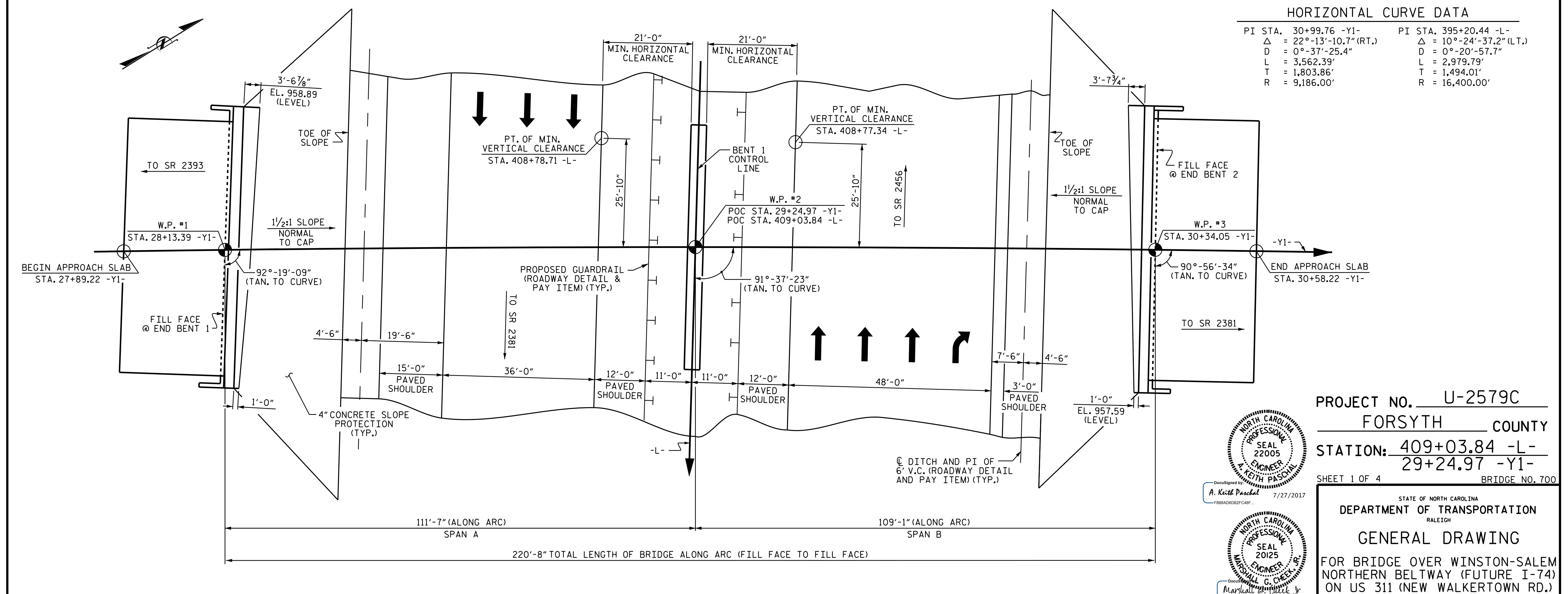
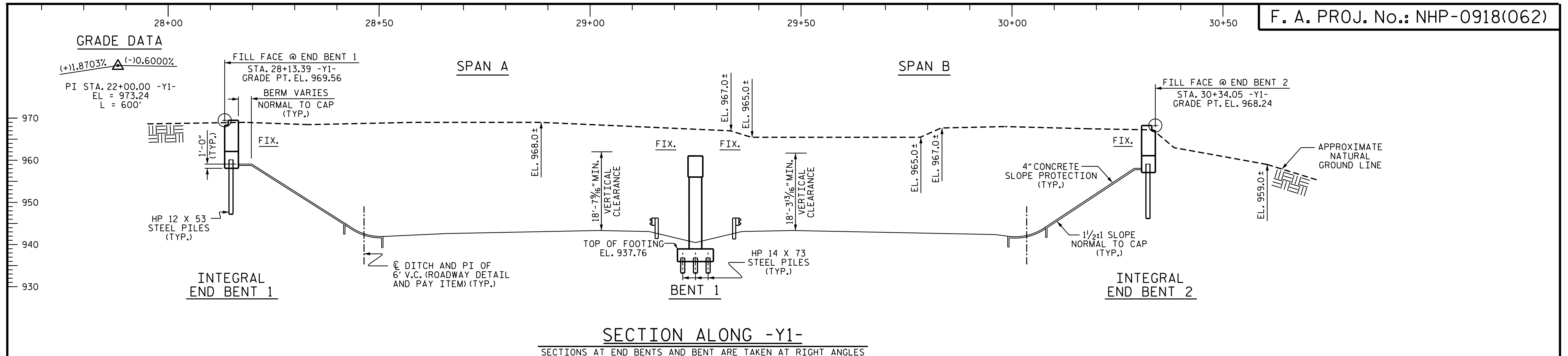

DRAWN BY : K. D. LAYNE DATE : 4/27/16
 CHECKED BY : J. K. BOWLES DATE : 9/8/16
 DESIGN ENGINEER OF RECORD : H.A. LOCKLEAR DATE : 6/2017

Professional Engineer Seal:
 NORTH CAROLINA PROFESSIONAL ENGINEER
 SEAL 22005
 KEITH PASCAL
 7/27/2017

Professional Engineer Seal:
 NORTH CAROLINA PROFESSIONAL ENGINEER
 SEAL 20125
 MARSHALL G. CHECK JR.
 7/27/2017

PROJECT NO. U-2579C
 FORSYTH COUNTY
 STATION: 409+03.84 -L-
 29+24.97 -Y1-
 SHEET 1 OF 4 BRIDGE NO. 700

STATE OF NORTH CAROLINA
 DEPARTMENT OF TRANSPORTATION
 RALEIGH
GENERAL DRAWING
 FOR BRIDGE OVER WINSTON-SALEM
 NORTHERN BELTWAY (FUTURE I-74)
 ON US 311 (NEW WALKERTOWN RD.)
 BETWEEN SR 2393 AND SR 2381

REVISIONS						SHEET NO.	
NO.	BY:	DATE:	NO.	BY:	DATE:	S1-1	
1			3			TOTAL SHEETS	
2			4			32	

DOCUMENT NOT CONSIDERED FINAL UNLESS ALL SIGNATURES COMPLETED

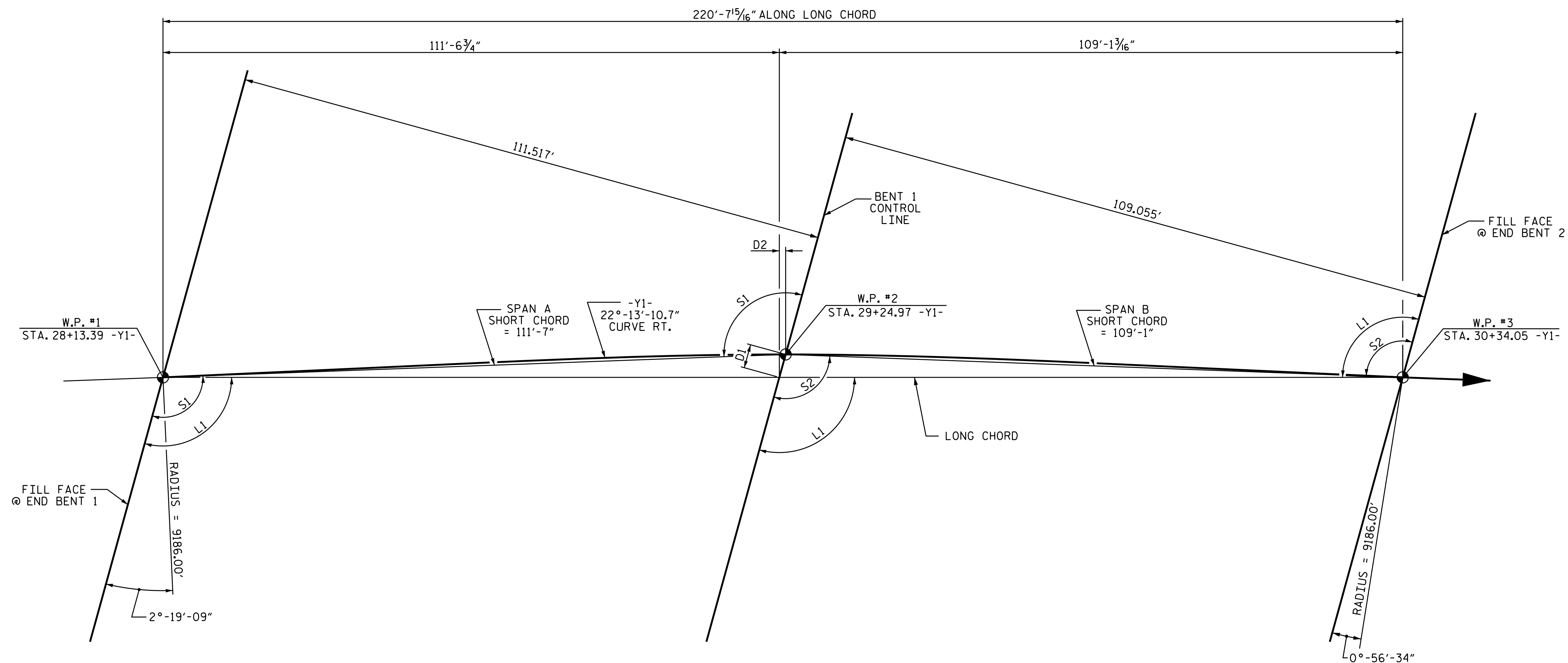

LONG CHORD LAYOUT

ANGLES			
LONG CHORD		SHORT CHORD	
L1	91°-37'-52"	S1	91°-58'-16"
		S2	91°-16'-58"

OFFSETS	
D1	7 ¹⁵ / ₁₆ "
D2	0 ¹ / ₄ "

PROJECT NO. U-2579C
FORSYTH COUNTY
 STATION: 409+03.84 -L-
29+24.97 -Y1-
 SHEET 2 OF 4

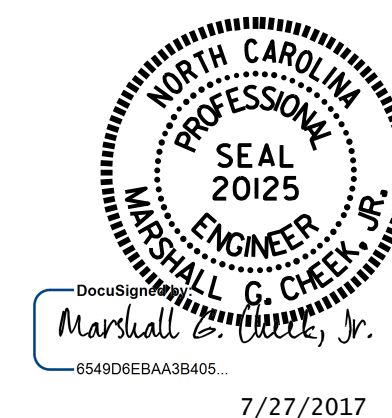

STATE OF NORTH CAROLINA
 DEPARTMENT OF TRANSPORTATION
 RALEIGH
GENERAL DRAWING
 FOR BRIDGE OVER WINSTON-SALEM
 NORTHERN BELTWAY (FUTURE I-74)
 ON US 311 (NEW WALKERTOWN RD.)
 BETWEEN SR 2393 AND SR 2381

DRAWN BY : K. D. LAYNE DATE : 4/27/16
 CHECKED BY : J.K. BOWLES DATE : 9/8/16
 DESIGN ENGINEER OF RECORD: H.A. LOCKLEAR DATE : 6/2017

DOCUMENT NOT CONSIDERED
 FINAL UNLESS ALL
 SIGNATURES COMPLETED

REVISIONS						SHEET NO.	
NO.	BY:	DATE:	NO.	BY:	DATE:	TOTAL SHEETS	
1			3			1	32
2			4				

NOTES

FOR PILES, SEE GEOTECHNICAL SPECIAL PROVISIONS AND SECTION 450 OF THE STANDARD SPECIFICATIONS.

PILES AT END BENT 1 AND END BENT 2 ARE DESIGNED FOR A FACTORED RESISTANCE OF 125 TONS PER PILE.

DRIVE PILES AT END BENT 1 AND END BENT 2 TO A REQUIRED DRIVING RESISTANCE OF 210 TONS PER PILE.

PILES AT BENT 1 ARE DESIGNED FOR A FACTORED RESISTANCE OF 125 TONS PER PILE.

DRIVE PILES AT BENT 1 TO A REQUIRED DRIVING RESISTANCE OF 210 TONS PER PILE.

STEEL PILE POINTS ARE REQUIRED FOR STEEL H-PILES AT BENT 1. FOR STEEL PILE POINTS, SEE SECTION 450 OF THE STANDARD SPECIFICATIONS.

TESTING PILES WITH THE PILE DRIVING ANALYZER (PDA) DURING DRIVING, RESTRIKING, OR REDRIVING MAY BE REQUIRED. THE ENGINEER WILL DETERMINE THE NEED FOR PDA TESTING. FOR PDA TESTING, SEE SECTION 450 OF THE STANDARD SPECIFICATIONS.

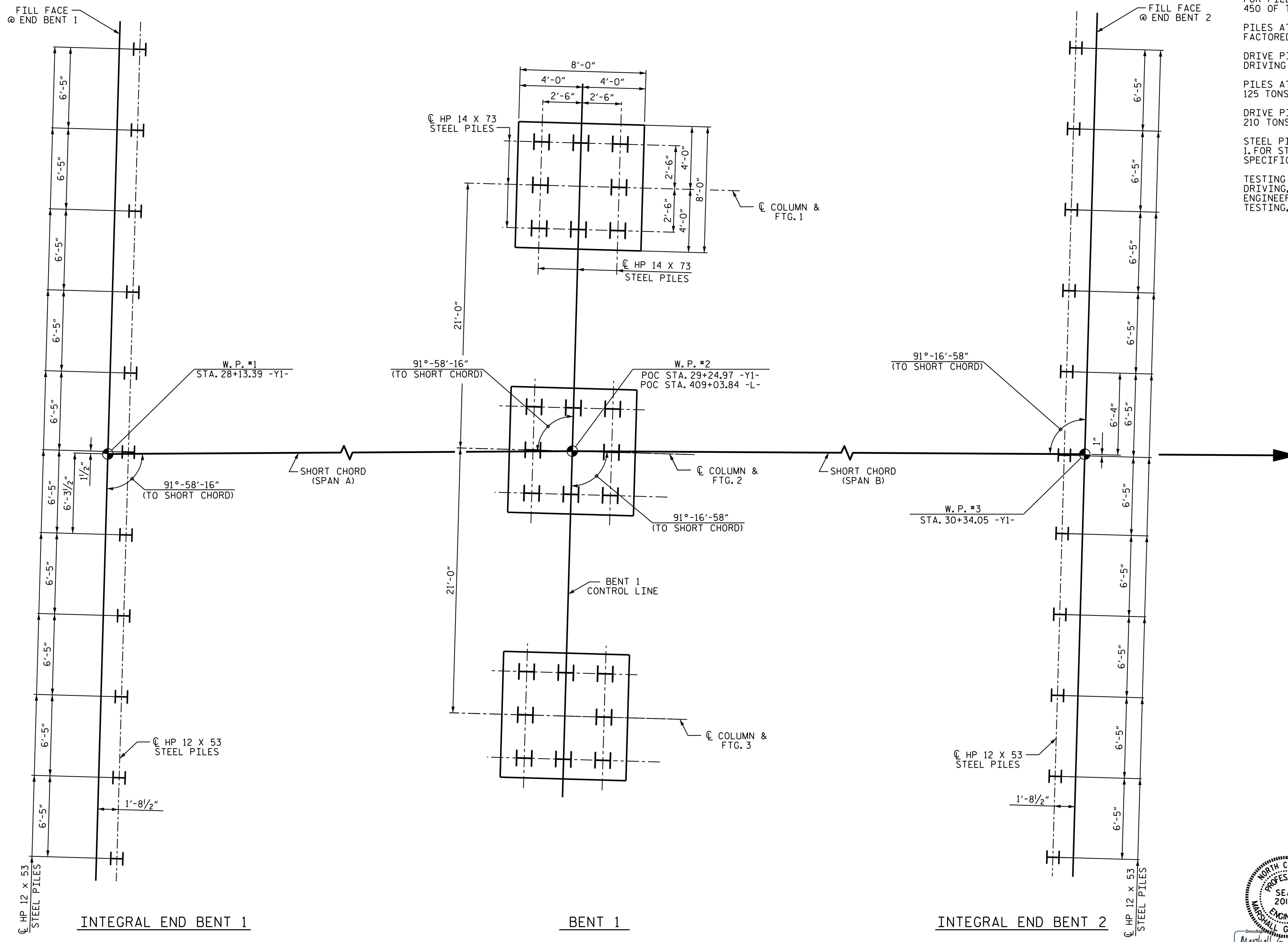

FOUNDATION LAYOUT
 DIMENSIONS LOCATING PILES ARE SHOWN TO THE CENTERLINE OF PILES.
 ALL COLUMN FOOTINGS AND PILE SPACINGS ARE TYPICAL AT BENT.

PROJECT NO. U-2579C
 FORSYTH COUNTY
 STATION: 409+03.84 -L-
29+24.97 -Y1-
 SHEET 3 OF 4

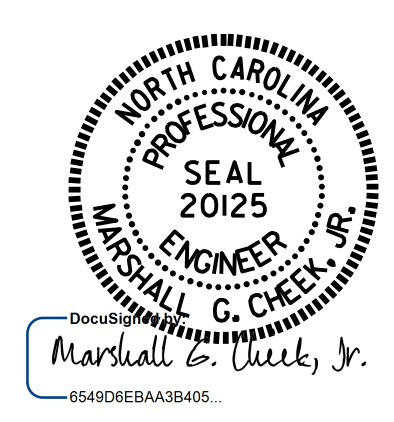

STATE OF NORTH CAROLINA
 DEPARTMENT OF TRANSPORTATION
 RALEIGH
GENERAL DRAWING
 FOR BRIDGE OVER WINSTON-SALEM
 NORTHERN BELTWAY (FUTURE I-74)
 ON US 311 (NEW WALKERTOWN RD.)
 BETWEEN SR 2393 AND SR 2381

DRAWN BY: K. D. LAYNE DATE: 4/27/16
 CHECKED BY: J.K. BOWLES DATE: 9/8/16
 DESIGN ENGINEER OF RECORD: H.A. LOCKLEAR DATE: 6/2017

DOCUMENT NOT CONSIDERED
 FINAL UNLESS ALL
 SIGNATURES COMPLETED

REVISIONS						SHEET NO.
NO.	BY:	DATE:	NO.	BY:	DATE:	S1-3
1			3			TOTAL SHEETS
2			4			32

BENCHMARK #2 : R.R. SPIKE SET IN BASE OF 36" OAK TREE 50' LT. OF STA. 47+42.00 -Y1-, EL. 985.60

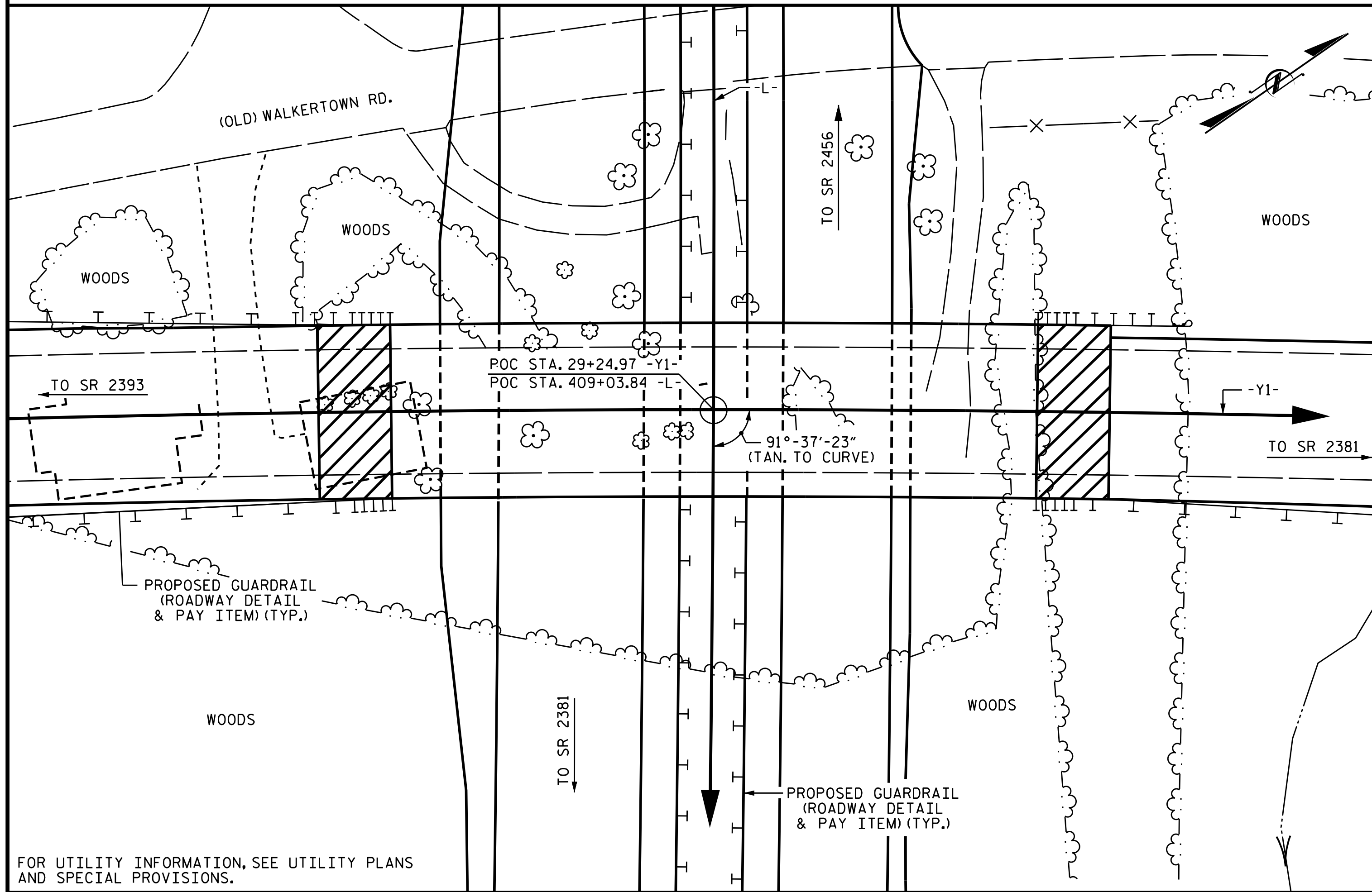

FOR UTILITY INFORMATION, SEE UTILITY PLANS AND SPECIAL PROVISIONS.

LOCATION SKETCH

NOTES

- ASSUMED LIVE LOAD = HL-93 OR ALTERNATE LOADING.
- THIS BRIDGE HAS BEEN DESIGNED IN ACCORDANCE WITH THE AASHTO LRFD BRIDGE DESIGN SPECIFICATIONS.
- THIS BRIDGE IS LOCATED IN SEISMIC ZONE 1.
- FOR OTHER DESIGN DATA AND GENERAL NOTES, SEE SHEET SN.
- FOR SUBMITTAL OF WORKING DRAWINGS, SEE SPECIAL PROVISIONS.
- FOR FALSEWORK AND FORMWORK, SEE SPECIAL PROVISIONS.
- FOR CRANE SAFETY, SEE SPECIAL PROVISIONS.
- FOR GROUT FOR STRUCTURES, SEE SPECIAL PROVISIONS.
- PRESTRESSED CONCRETE DECK PANELS MAY BE USED IN LIEU OF METAL STAY-IN-PLACE FORMS IN ACCORDANCE WITH ARTICLE 420-3 OF THE STANDARD SPECIFICATIONS.
- REMOVABLE FORMS MAY BE USED IN LIEU OF METAL STAY-IN-PLACE FORMS IN ACCORDANCE WITH ARTICLE 420-3 OF THE STANDARD SPECIFICATIONS.
- THE ELEVATIONS AND CLEARANCES SHOWN ON THE PLANS AT THE POINTS OF MINIMUM VERTICAL CLEARANCE ARE FROM THE BEST INFORMATION AVAILABLE. PRIOR TO BEGINNING BRIDGE CONSTRUCTION, VERIFY THE ELEVATIONS ON THE EXISTING PAVEMENT AND CHECK THE CLEARANCE. REPORT ANY VARIATIONS TO THE ENGINEER. ANY PLAN REVISIONS NECESSARY TO ACHIEVE THE REQUIRED MINIMUM VERTICAL CLEARANCE WILL BE PROVIDED BY THE DEPARTMENT.

THE CONTRACTOR SHALL PROVIDE INDEPENDENT ASSURANCE SAMPLES OF REINFORCING STEEL AS FOLLOWS: FOR PROJECTS REQUIRING UP TO 400 TONS OF REINFORCING STEEL, ONE 30 INCH SAMPLE OF EACH SIZE BAR USED, AND FOR PROJECTS REQUIRING OVER 400 TONS OF REINFORCING STEEL, TWO 30 INCH SAMPLES OF EACH SIZE BAR USED. THE BARS FROM WHICH THE SAMPLES ARE TAKEN MUST THEN BE SPLICED WITH REPLACEMENT BARS OF THE SIZE AND LENGTH OF THE SAMPLE, PLUS A MINIMUM LAP SPLICE OF THIRTY BAR DIAMETERS. PAYMENT FOR THE SAMPLES OF REINFORCING STEEL SHALL BE CONSIDERED INCIDENTAL TO VARIOUS PAY ITEMS.

NEEDLE BEAMS WILL NOT BE ALLOWED UNLESS OTHERWISE CALLED FOR ON THE PLANS OR APPROVED BY THE ENGINEER.

THE CLASS AA CONCRETE IN THE BRIDGE DECK SHALL CONTAIN FLY ASH OR GROUND GRANULATED BLAST FURNACE SLAG AT THE SUBSTITUTION RATE SPECIFIED IN ARTICLE 1024-1 AND IN ACCORDANCE WITH ARTICLES 1024-5 AND 1024-6 OF THE STANDARD SPECIFICATIONS. NO PAYMENT WILL BE MADE FOR THIS SUBSTITUTION AS IT IS CONSIDERED INCIDENTAL TO THE COST OF THE REINFORCED CONCRETE DECK SLAB.

FOR EROSION CONTROL MEASURES, SEE EROSION CONTROL PLANS.

FOR PLACING LOAD ON STRUCTURE MEMBERS, SEE SPECIAL PROVISIONS.

FOR EMBEDDED CLIPS FOR PRESTRESSED CONCRETE GIRDERS, SEE SPECIAL PROVISIONS.

TOTAL BILL OF MATERIAL

	FOUNDATION EXCAVATION FOR BENT	PDA TESTING	REINFORCED CONCRETE DECK SLAB	GROOVING BRIDGE FLOORS	CLASS A CONCRETE	BRIDGE APPROACH SLABS	REINFORCING STEEL	SPIRAL COLUMN REINFORCING STEEL	MODIFIED 72" PRESTRESSED CONCRETE GIRDERS	PILE DRIVING EQUIPMENT SETUP FOR HP 12 X 53 STEEL PILES	PILE DRIVING EQUIPMENT SETUP FOR HP 14 X 73 STEEL PILES	HP 12 x 53 STEEL PILES		HP 14 x 73 STEEL PILES		STEEL PILE POINTS	CONCRETE BARRIER RAIL	4" SLOPE PROTECTION	ELASTOMERIC BEARINGS	
	LUMP SUM	EACH	SQ. FT.	SQ. FT.	CU. YDS.	LUMP SUM	LBS.	LBS.	NO. LIN. FT.	EACH	EACH	NO.	LIN. FT.	NO.	LIN. FT.	EACH	LIN. FT.	SQ. YDS.	LUMP SUM	
SUPERSTRUCTURE			13,406	10,280		LUMP SUM			12 1,307.00								438.00		LUMP SUM	
END BENT 1					52.7		6,053			11		11	470						440	
BENT 1	LUMP SUM				80.4		16,962	1,281			24			24	480	24				
END BENT 2					48.4		6,033			11		11	415						386	
TOTAL	LUMP SUM	1	13,406	10,280	181.5	LUMP SUM	29,048	1,281	12 1,307.00	22	24	22	885	24	480	24	438.00	826	LUMP SUM	

PROJECT NO. U-2579C
FORSYTH COUNTY
 STATION: 409+03.84 -L-
29+24.97 -Y1-
 SHEET 4 OF 4

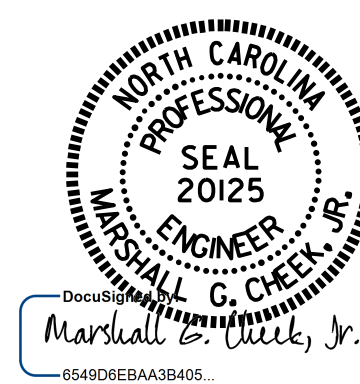

STATE OF NORTH CAROLINA
 DEPARTMENT OF TRANSPORTATION
 RALEIGH
GENERAL DRAWING
 FOR BRIDGE OVER WINSTON-SALEM
 NORTHERN BELTWAY (FUTURE I-74)
 ON US 311 (NEW WALKERTOWN RD.)
 BETWEEN SR 2393 AND SR 2381

DRAWN BY : K. D. LAYNE DATE : 4/27/16
 CHECKED BY : J.K. BOWLES DATE : 9/8/16
 DESIGN ENGINEER OF RECORD: H.A. LOCKLEAR DATE : 6/2017

DOCUMENT NOT CONSIDERED FINAL UNLESS ALL SIGNATURES COMPLETED

REVISIONS						SHEET NO.
NO.	BY:	DATE:	NO.	BY:	DATE:	S1-4
1			3			TOTAL SHEETS
2			4			32

LOAD FACTORS:

DESIGN LOAD RATING FACTORS	LIMIT STATE	γ_{DC}	γ_{DW}
	STRENGTH I	1.25	1.50
	SERVICE III	1.00	1.00

LOAD AND RESISTANCE FACTOR RATING (LRFD) SUMMARY FOR PRESTRESSED CONCRETE GIRDERS

LEVEL	VEHICLE	WEIGHT (W) (TONS)	CONTROLLING LOAD RATING #	MINIMUM RATING FACTORS (RF)	TONS = W X RF	STRENGTH I LIMIT STATE								SERVICE III LIMIT STATE								COMMENT NUMBER		
						MOMENT					SHEAR			MOMENT										
						LIVE-LOAD FACTORS (γ_{LL})	DISTRIBUTION FACTORS (DF)	RATING FACTOR	SPAN	GIRDER LOCATION	DISTANCE FROM LEFT END OF SPAN (ft)	DISTRIBUTION FACTORS (DF)	RATING FACTOR	SPAN	GIRDER LOCATION	DISTANCE FROM LEFT END OF SPAN (ft)	LIVE-LOAD FACTORS (γ_{LL})	DISTRIBUTION FACTORS (DF)	RATING FACTOR	SPAN	GIRDER LOCATION		DISTANCE FROM LEFT END OF SPAN (ft)	
DESIGN LOAD RATING	HL-93 (INVENTORY)	N/A	1	1.01	--	1.75	0.958	1.50	A	EL	54.374	0.964	1.27	A	EL	76.124	0.80	0.958	1.01	A	EL	54.374		
	HL-93 (OPERATING)	N/A	--	1.65	--	1.35	0.958	1.95	A	EL	54.374	0.964	1.65	A	EL	76.124	N/A	--	--	--	--	--		
	HS-20 (INVENTORY)	36.000	2	1.43	51.580	1.75	0.958	2.14	A	EL	54.374	0.964	1.63	A	EL	76.124	0.80	0.958	1.43	A	EL	54.374		
	HS-20 (OPERATING)	36.000	--	2.12	76.161	1.35	0.958	2.77	A	EL	54.374	0.964	2.12	A	EL	76.124	N/A	--	--	--	--	--		
LEGAL LOAD RATING	SINGLE VEHICLE (SV)	SNSH	13.500	--	3.44	46.415	1.40	0.958	6.42	A	EL	54.374	0.964	4.94	A	EL	76.124	0.80	0.958	3.44	A	EL	54.374	
		SNGARBS2	20.000	--	2.47	49.454	1.40	0.958	4.62	A	EL	54.374	0.964	3.49	A	EL	76.124	0.80	0.958	2.47	A	EL	54.374	
		SNAGRIS2	22.000	--	2.31	50.733	1.40	0.958	4.31	A	EL	54.374	0.964	3.23	A	EL	76.124	0.80	0.958	2.31	A	EL	54.374	
		SNCOTTS3	27.250	--	1.71	46.550	1.40	0.958	3.19	A	EL	54.374	0.964	2.46	A	EL	76.124	0.80	0.958	1.71	A	EL	54.374	
		SNAGGRS4	34.925	--	1.39	48.652	1.40	0.958	2.60	A	EL	54.374	0.964	2.03	A	EL	76.124	0.80	0.958	1.39	A	EL	54.374	
		SNS5A	35.550	--	1.37	48.509	1.40	0.958	2.55	A	EL	54.374	0.964	2.04	A	EL	76.124	0.80	0.958	1.36	A	EL	54.374	
		SNS6A	39.950	--	1.24	49.458	1.40	0.958	2.31	A	EL	54.374	0.964	1.86	A	EL	76.124	0.80	0.958	1.24	A	EL	54.374	
	SNS7B	42.000	--	1.18	49.494	1.40	0.958	2.20	A	EL	54.374	0.964	1.81	A	EL	76.124	0.80	0.958	1.18	A	EL	54.374		
	TRUCK TRACTOR SEMI-TRAILER (TTST)	TNAGRIT3	33.000	--	1.51	49.684	1.40	0.958	2.81	A	EL	54.374	0.964	2.21	A	EL	76.124	0.80	0.958	1.51	A	EL	54.374	
		TNT4A	33.075	--	1.51	49.892	1.40	0.958	2.82	A	EL	54.374	0.964	2.17	A	EL	76.124	0.80	0.958	1.51	A	EL	54.374	
		TNT6A	41.600	--	1.22	50.769	1.40	0.958	2.28	A	EL	54.374	0.964	1.91	A	EL	76.124	0.80	0.958	1.22	A	EL	54.374	
		TNT7A	42.000	--	1.22	51.227	1.40	0.958	2.28	A	EL	54.374	0.964	1.88	A	EL	76.124	0.80	0.958	1.22	A	EL	54.374	
		TNT7B	42.000	--	1.25	52.302	1.40	0.958	2.33	A	EL	54.374	0.964	1.78	A	EL	76.124	0.80	0.958	1.25	A	EL	54.374	
		TNAGRIT4	43.000	--	1.20	51.466	1.40	0.958	2.23	A	EL	54.374	0.964	1.72	A	EL	76.124	0.80	0.958	1.20	A	EL	54.374	
TNAGT5A		45.000	--	1.13	51.044	1.40	0.958	2.12	A	EL	54.374	0.964	1.70	A	EL	76.124	0.80	0.958	1.13	A	EL	54.374		
TNAGT5B	45.000	3	1.13	50.662	1.40	0.958	2.10	A	EL	54.374	0.964	1.64	A	EL	76.124	0.80	0.958	1.13	A	EL	54.374			

NOTES:

MINIMUM RATING FACTORS ARE BASED ON THE STRENGTH I AND SERVICE III LIMIT STATES.
ALLOWABLE STRESSES FOR SERVICE III LIMIT STATE ARE AS REQUIRED FOR DESIGN.

CONTROLLING LOAD RATING

1 DESIGN LOAD RATING (HL-93)

2 DESIGN LOAD RATING (HS-20)

3 LEGAL LOAD RATING **

** SEE CHART FOR VEHICLE TYPE

GIRDER LOCATION

I - INTERIOR GIRDER
EL - EXTERIOR LEFT GIRDER
ER - EXTERIOR RIGHT GIRDER

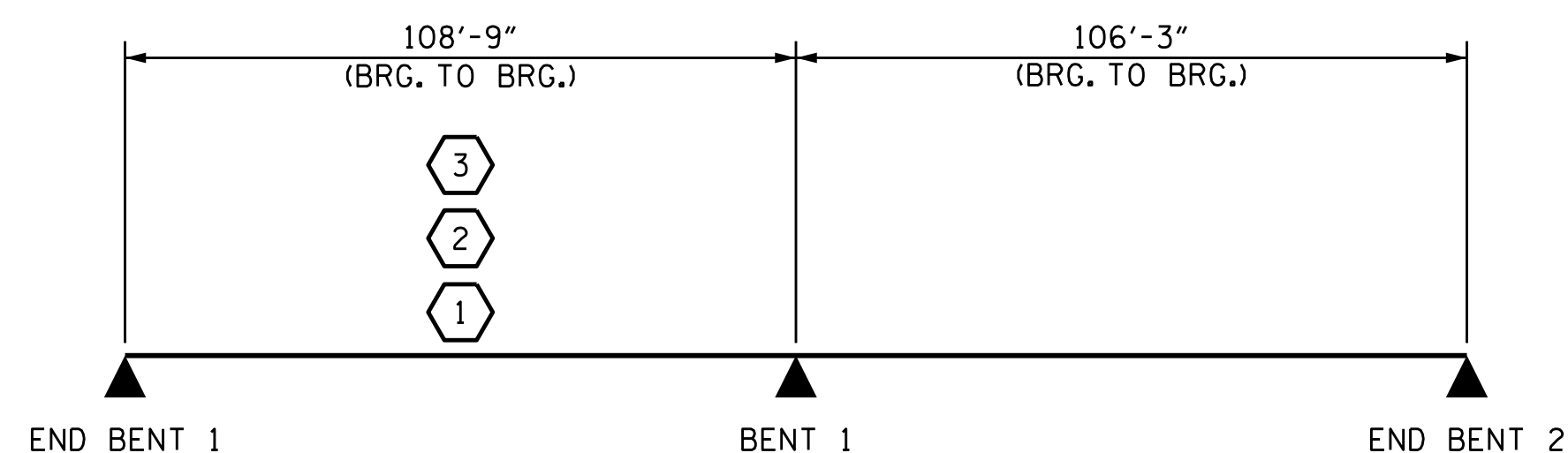

LRFR SUMMARY

PROJECT NO. U-2579C
FORSYTH COUNTY
 STATION: 29+24.97 -Y1-



STATE OF NORTH CAROLINA
 DEPARTMENT OF TRANSPORTATION
 RALEIGH

STANDARD
 LRFR SUMMARY FOR
 PRESTRESSED
 CONCRETE GIRDERS
 (NON-INTERSTATE TRAFFIC)

ASSEMBLED BY : J.P. MCCARTHA	DATE : 3/8/16
CHECKED BY : H.A. LOCKLEAR	DATE : 9/7/16
DRAWN BY : MAA 1/08	REV. 11/27/08RR MAA/GM
CHECKED BY : GM/DI 2/08	REV. 10/1/11 MAA/GM

DOCUMENT NOT CONSIDERED
 FINAL UNLESS ALL
 SIGNATURES COMPLETED

REVISIONS						SHEET NO.
NO.	BY:	DATE:	NO.	BY:	DATE:	S1-5
1			3			TOTAL SHEETS
2			4			32

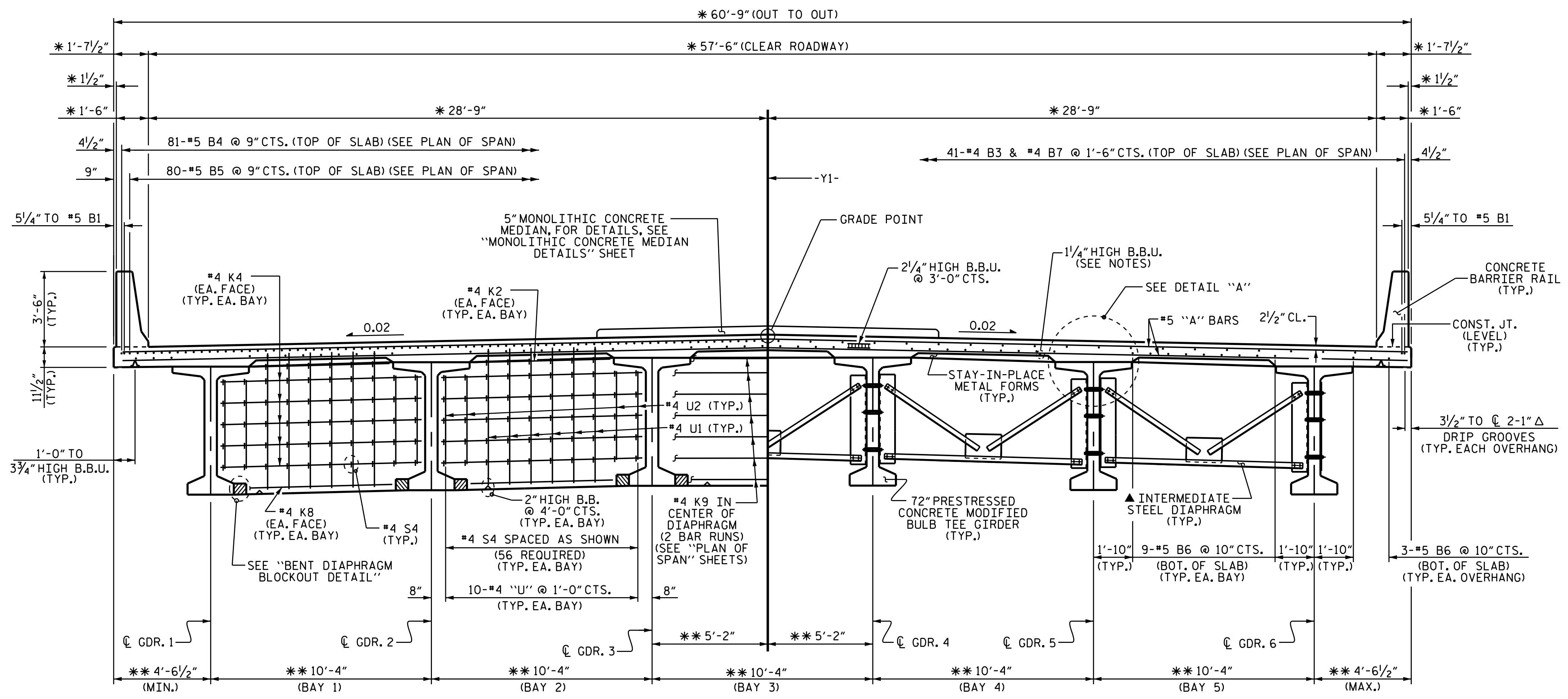

NOTES

PROVIDE 1/4" HIGH BEAM BOLSTERS UPPER AT 4'-0" CTS. ATOP THE METAL STAY-IN-PLACE FORMS TO SUPPORT THE BOTTOM MAT OF "A" BARS. WHEN USING REMOVABLE FORMS, PROVIDE CONTINUOUS HIGH CHAIRS FOR METAL DECK (C.H.C.M.) @ 4'-0" CTS. WITH A HEIGHT TO SUPPORT THE BOTTOM MAT OF "A" BARS A CLEAR DISTANCE OF 2 1/2" ABOVE THE TOP OF THE REMOVABLE FORM.

LONGITUDINAL STEEL MAY BE SHIFTED SLIGHTLY, AS NECESSARY, TO AVOID INTERFERENCE WITH STIRRUPS IN PRESTRESSED CONCRETE GIRDERS.

PREVIOUSLY CAST CONCRETE IN A CONTINUOUS UNIT SHALL HAVE ATTAINED A MINIMUM COMPRESSIVE STRENGTH OF 3,000 PSI BEFORE ADDITIONAL CONCRETE IS CAST IN THE UNIT.

▲ FOR INTERMEDIATE STEEL DIAPHRAGM DETAILS, SEE "INTERMEDIATE STEEL DIAPHRAGMS FOR 72" MODIFIED BULB TEE PRESTRESSED CONCRETE GIRDERS" SHEET.

AT BENT DIAPHRAGMS

AT INTERMEDIATE DIAPHRAGMS

* RADIAL DIMENSIONS
** RADIAL DIMENSIONS THRU WORK POINT

TYPICAL SECTION

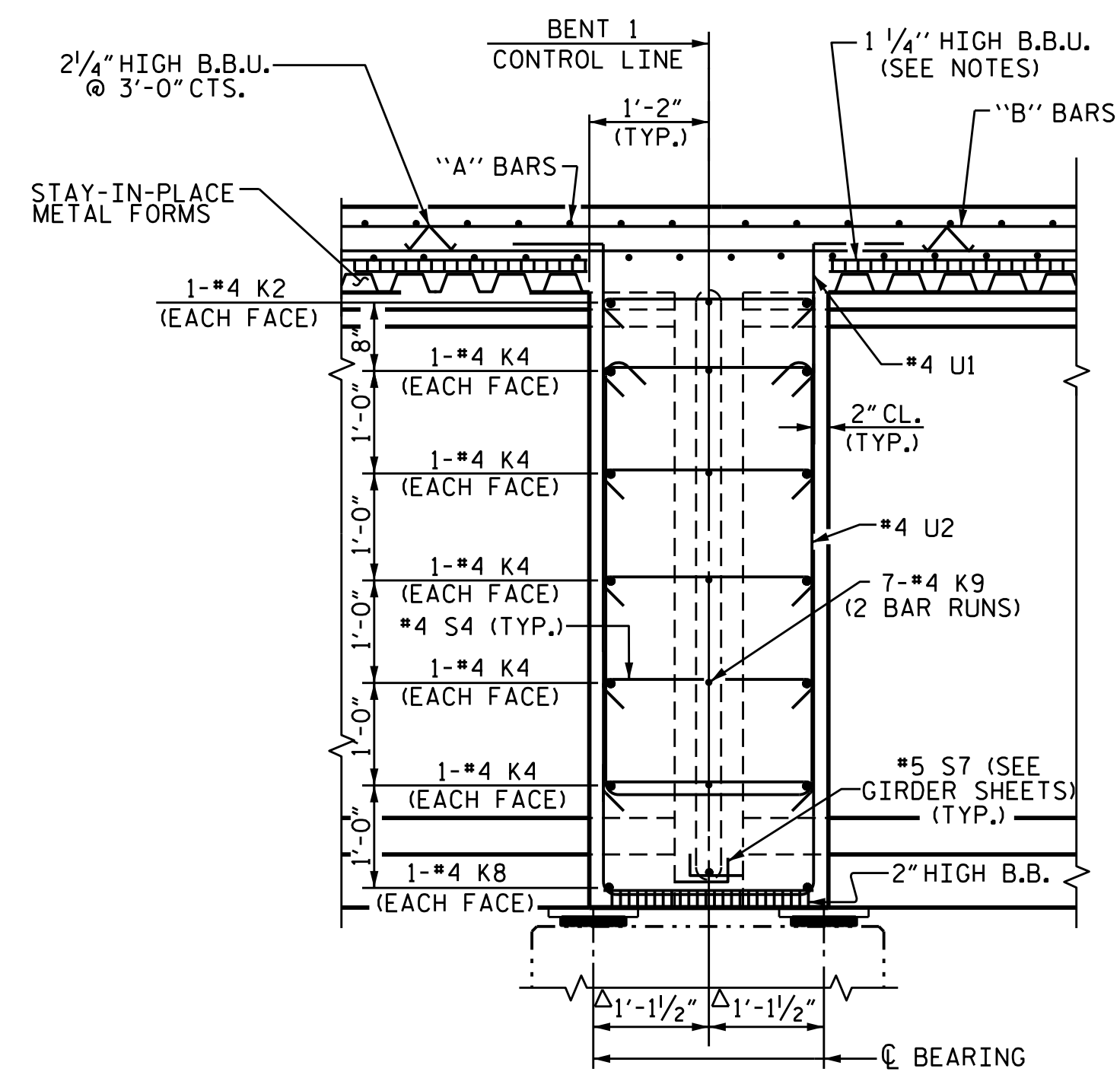

SECTION THRU BENT DIAPHRAGM

Δ MEASURED ALONG GDR.

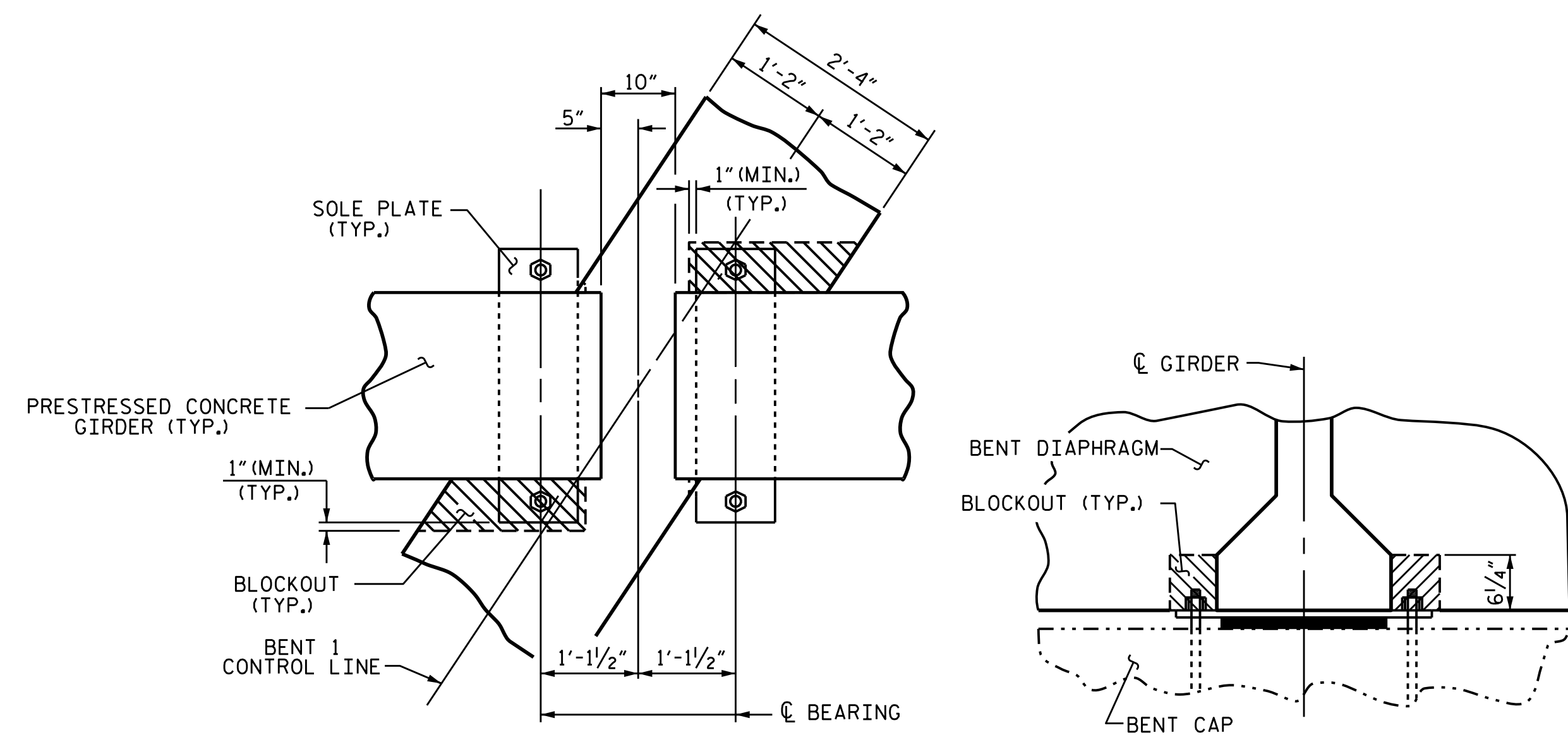

PLAN

SECTION

BENT DIAPHRAGM BLOCKOUT DETAIL

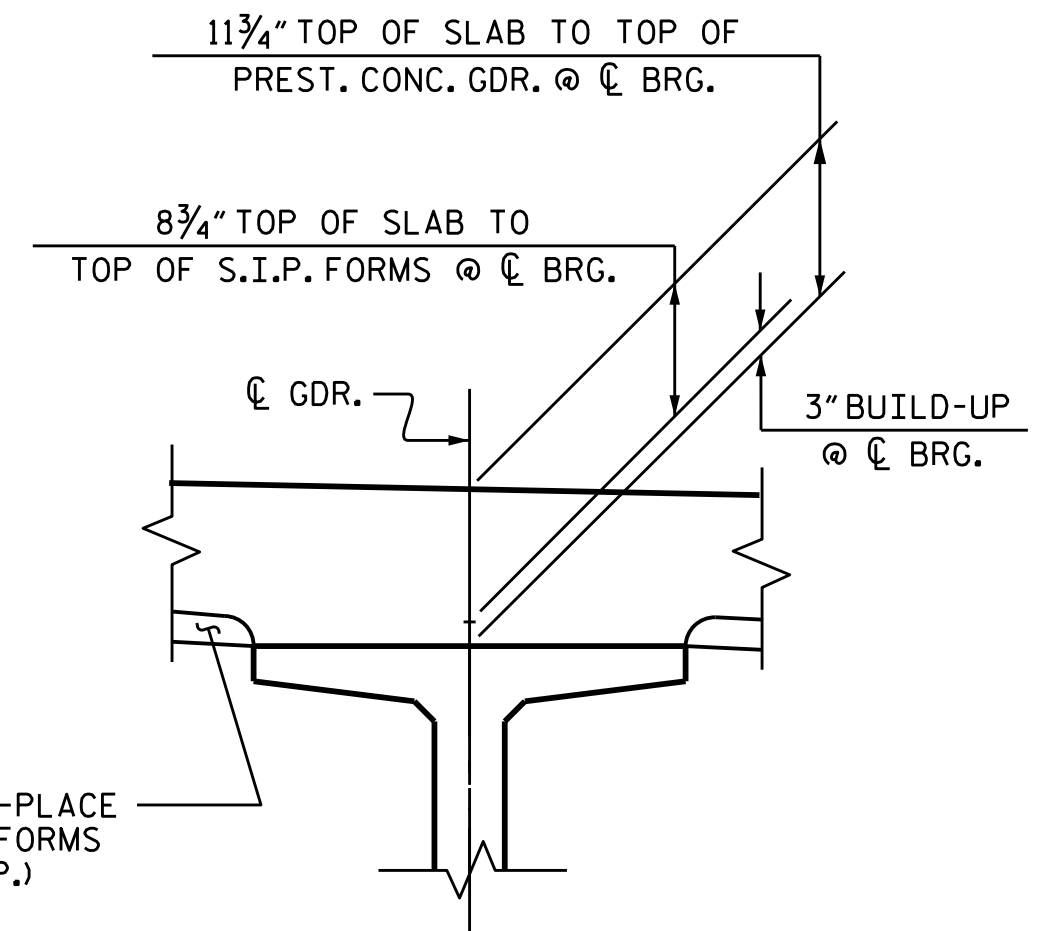

DETAIL "A"

PROJECT NO. U-2579C
FORSYTH COUNTY
 STATION: 29+24.97 -Y1-

SHEET 1 OF 2



7/27/2017

STATE OF NORTH CAROLINA
 DEPARTMENT OF TRANSPORTATION
 RALEIGH
 SUPERSTRUCTURE
 TYPICAL SECTION

DRAWN BY : J.P. MCCARTHA DATE : 4/15/16
 CHECKED BY : H.A. LOCKLEAR DATE : 8/26/16
 DESIGN ENGINEER OF RECORD: H.A. LOCKLEAR DATE : 6/2017

DOCUMENT NOT CONSIDERED FINAL UNLESS ALL SIGNATURES COMPLETED

REVISIONS						SHEET NO.	
NO.	BY:	DATE:	NO.	BY:	DATE:	S1-6	
1			3			TOTAL SHEETS	
2			4			32	

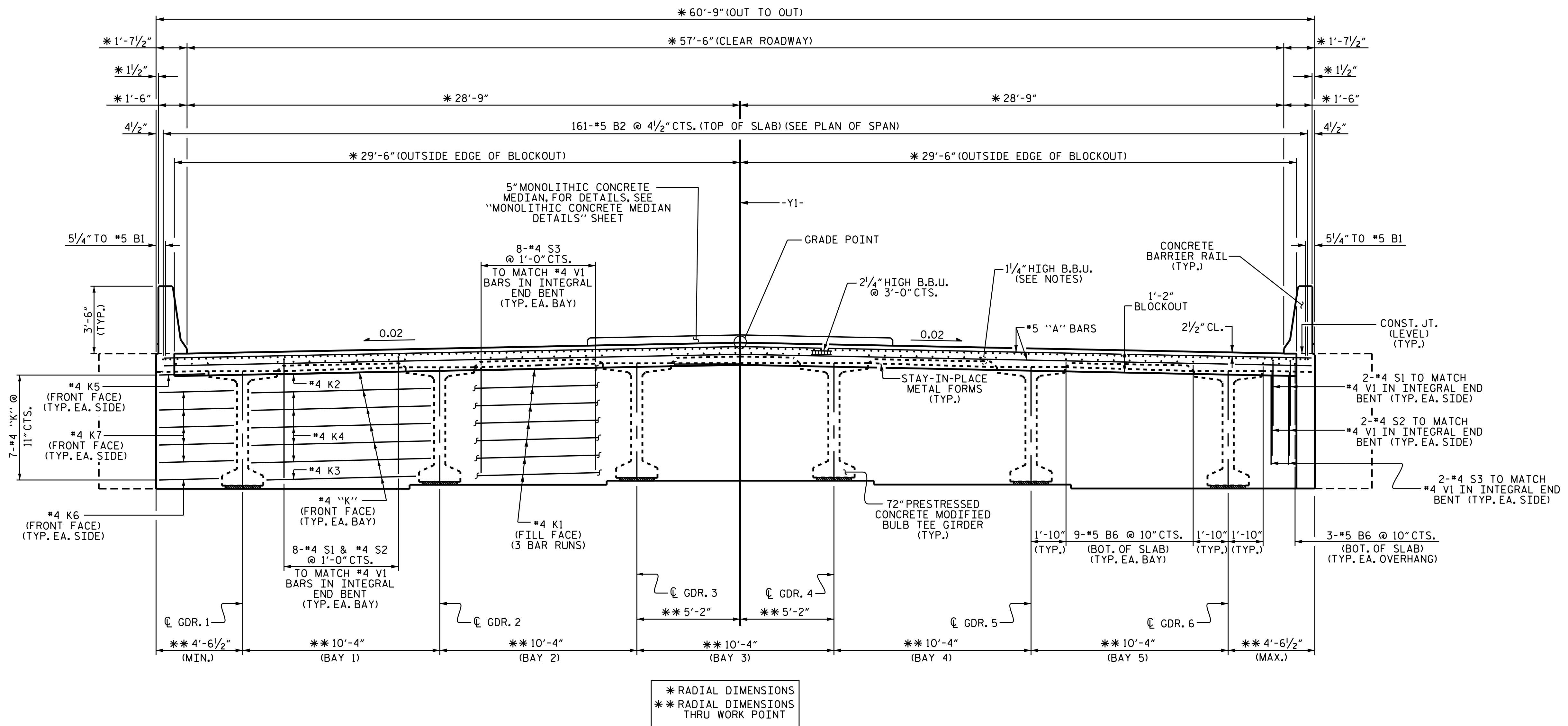

TYPICAL SECTION AT INTEGRAL END BENT

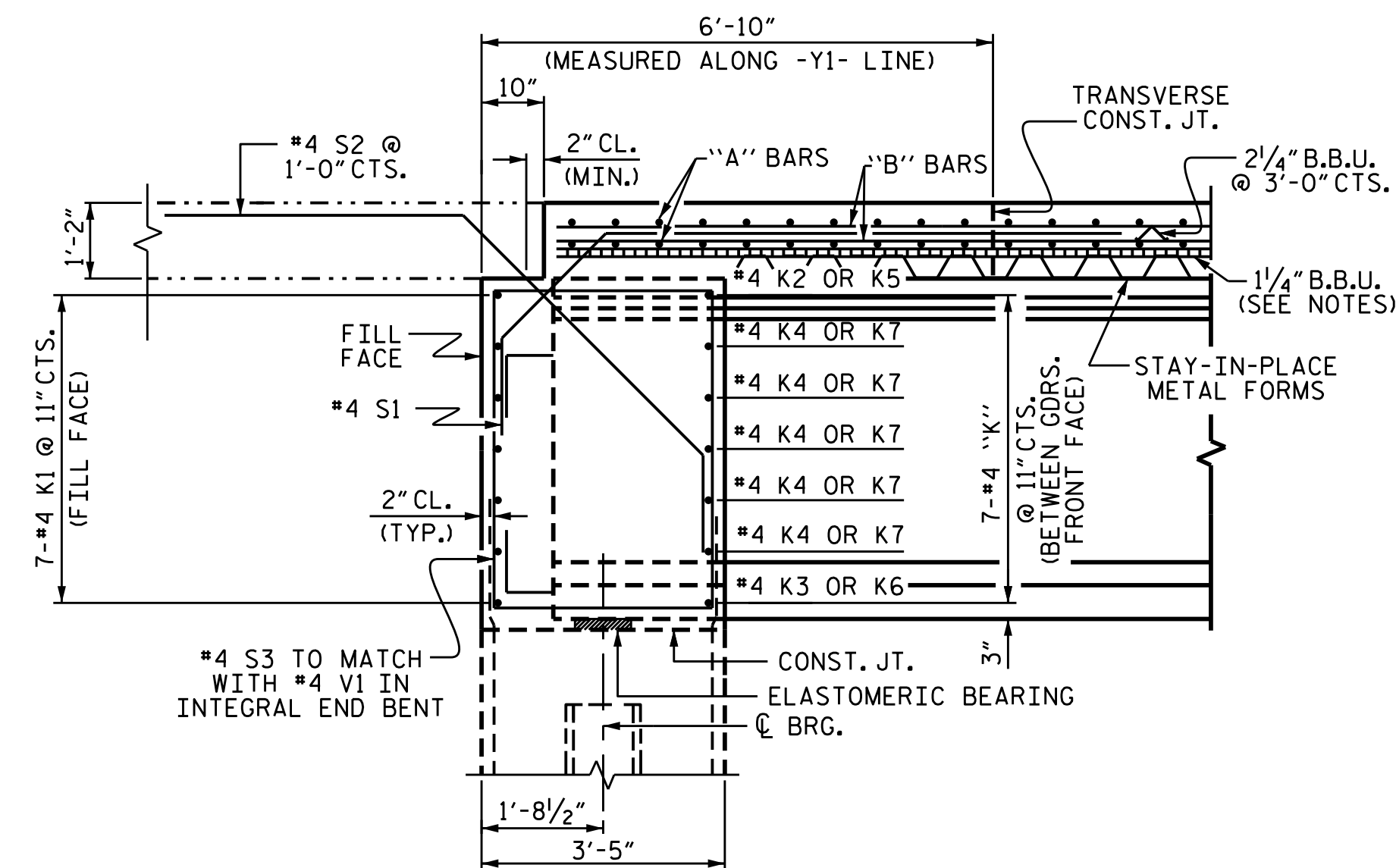

SECTION THROUGH INTEGRAL END BENT

PROJECT NO. U-2579C
 FORSYTH COUNTY
 STATION: 29+24.97 -Y1-
 SHEET 2 OF 2

STATE OF NORTH CAROLINA
 DEPARTMENT OF TRANSPORTATION
 RALEIGH
 SUPERSTRUCTURE
 TYPICAL SECTION

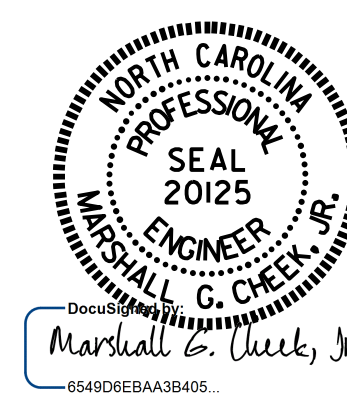

DRAWN BY: J.P. MCCARTHA DATE: 4/15/16
 CHECKED BY: H.A. LOCKLEAR DATE: 8/25/16
 DESIGN ENGINEER OF RECORD: H.A. LOCKLEAR DATE: 6/2017

DOCUMENT NOT CONSIDERED
 FINAL UNLESS ALL
 SIGNATURES COMPLETED

REVISIONS						SHEET NO.
NO.	BY:	DATE:	NO.	BY:	DATE:	S1-7
1			3			TOTAL SHEETS
2			4			32

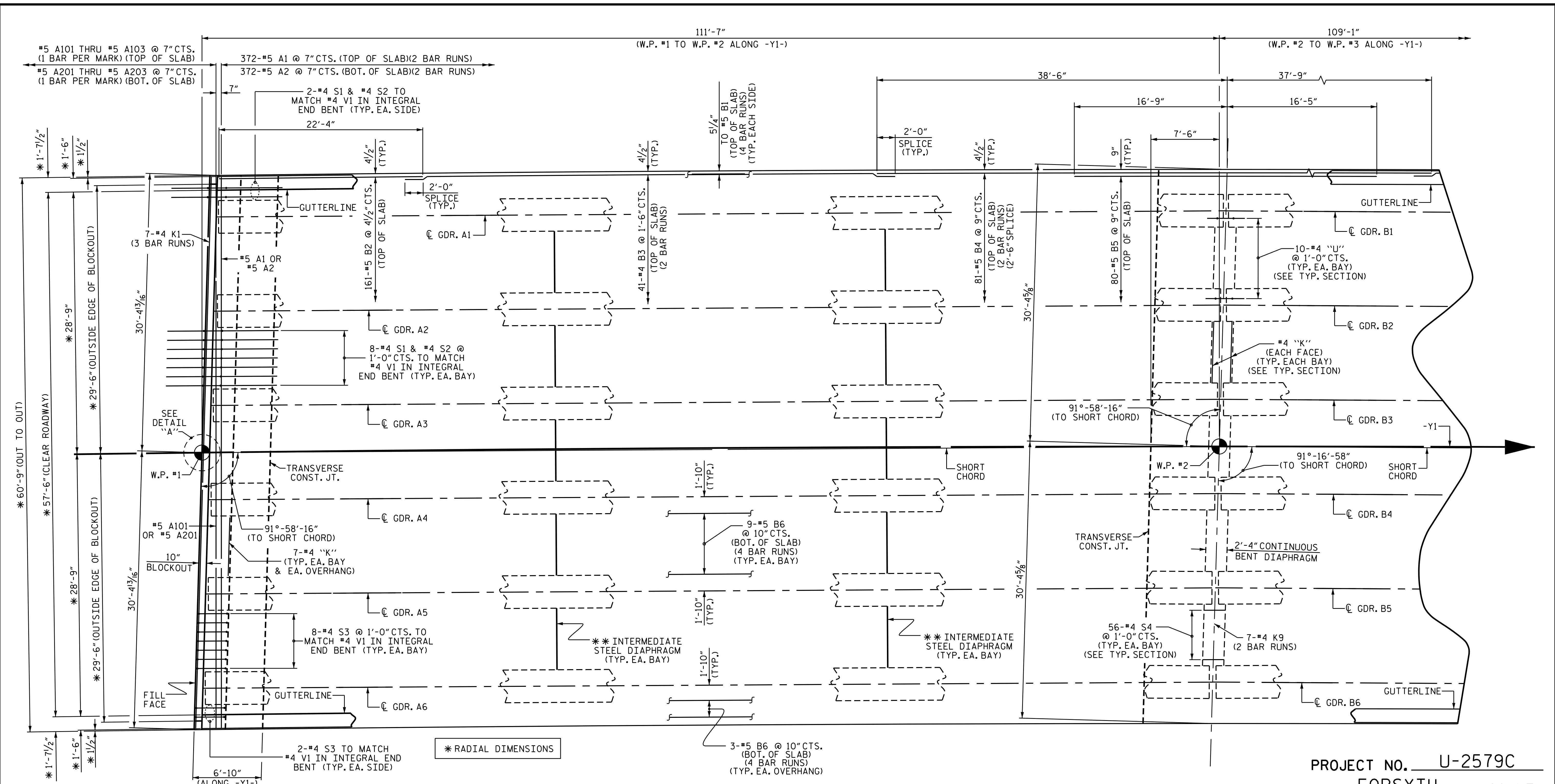

PLAN OF SPAN A

** FOR INTERMEDIATE STEEL DIAPHRAGMS DETAILS, SEE "INTERMEDIATE STEEL DIAPHRAGMS FOR 72" MODIFIED BULB TEE PRESTRESSED CONCRETE GIRDERS" SHEET.
 "A" BARS ARE SPACED ALONG AND PERPENDICULAR TO LONG CHORD.

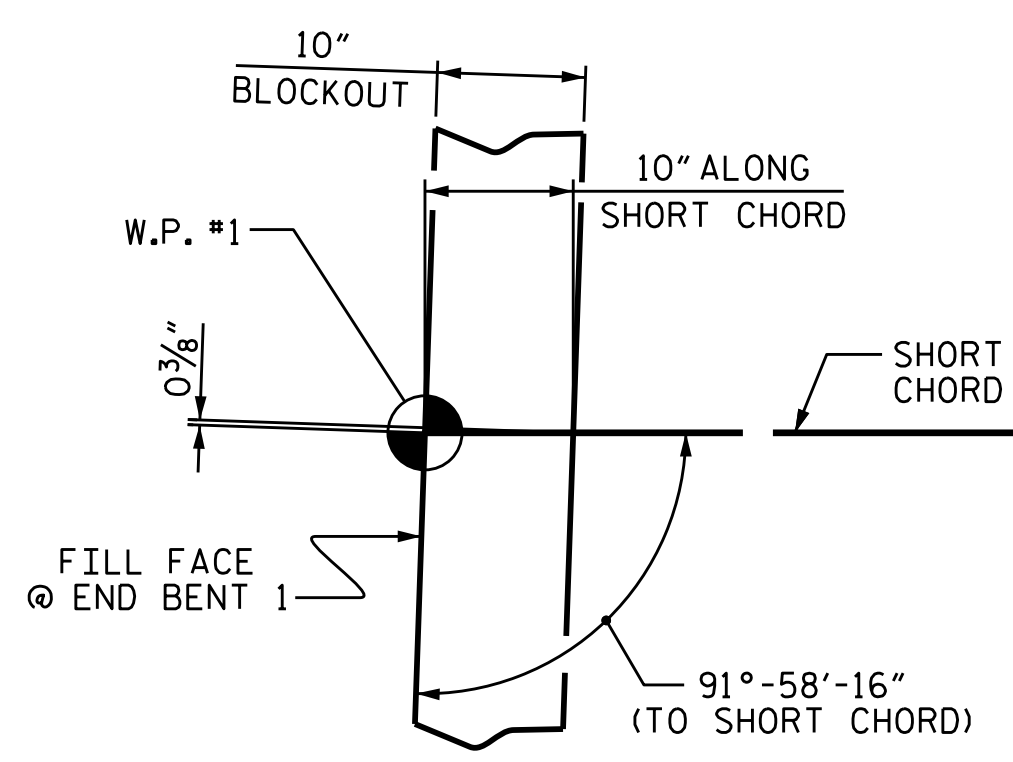

DETAIL "A"

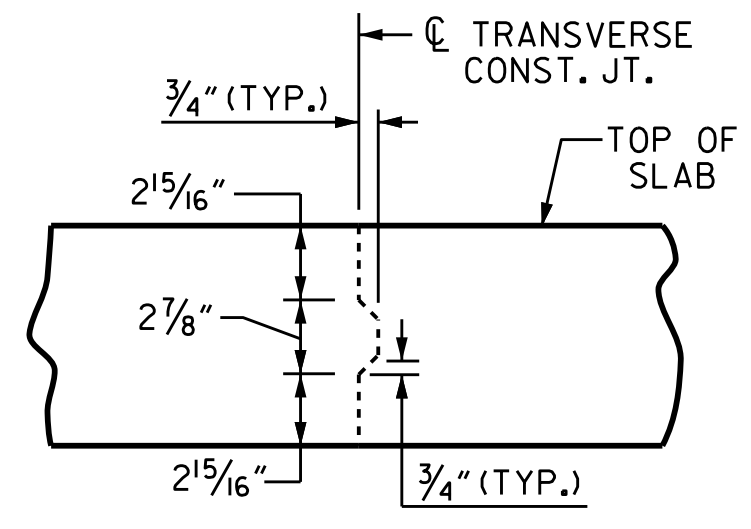

TRANSVERSE CONSTRUCTION JOINT

NOTE: REINFORCING STEEL IN SLAB NOT SHOWN. LONGITUDINAL REINFORCING STEEL SHALL BE CONTINUOUS THROUGH JOINT.

PROJECT NO. U-2579C
 FORSYTH COUNTY
 STATION: 29+24.97 -Y1-

SHEET 1 OF 3

STATE OF NORTH CAROLINA
 DEPARTMENT OF TRANSPORTATION
 RALEIGH
 SUPERSTRUCTURE
 PLAN OF SPAN A

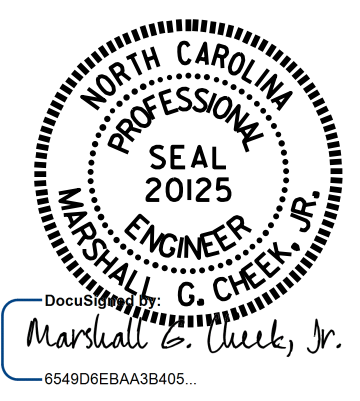

7/27/2017

DRAWN BY: J.P. MCCARTHA DATE: 4/26/16
 CHECKED BY: H.A. LOCKLEAR DATE: 8/25/16
 DESIGN ENGINEER OF RECORD: H.A. LOCKLEAR DATE: 6/2017

REVISIONS						SHEET NO.	
NO.	BY:	DATE:	NO.	BY:	DATE:	S1-8	
1			3			TOTAL SHEETS	
2			4			32	

STR. #1

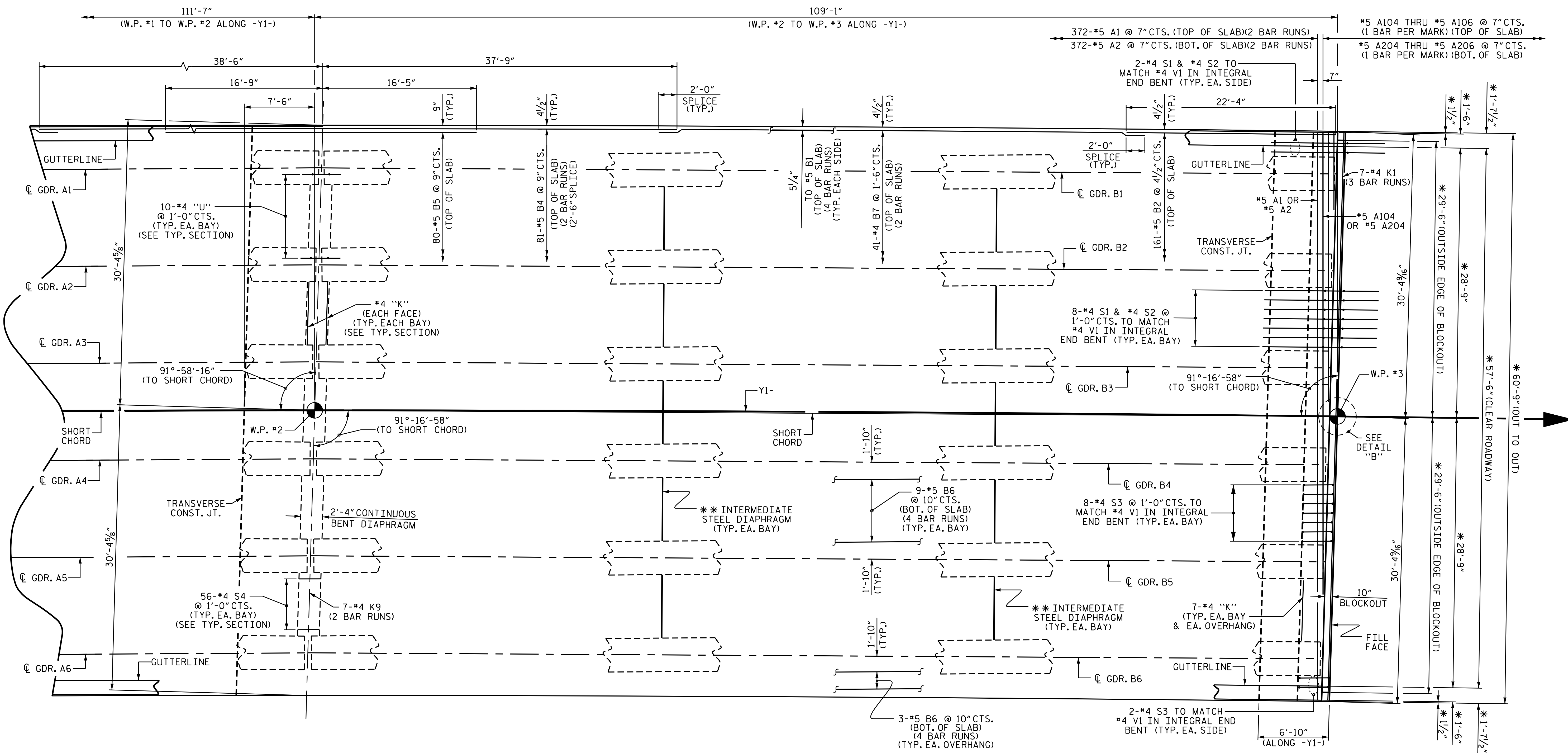

* RADIAL DIMENSIONS

PLAN OF SPAN B

** FOR INTERMEDIATE STEEL DIAPHRAGMS DETAILS, SEE "INTERMEDIATE STEEL DIAPHRAGMS FOR 72" MODIFIED BULB TEE PRESTRESSED CONCRETE GIRDERS" SHEET.

** "A" BARS ARE SPACED ALONG AND PERPENDICULAR TO LONG CHORD.

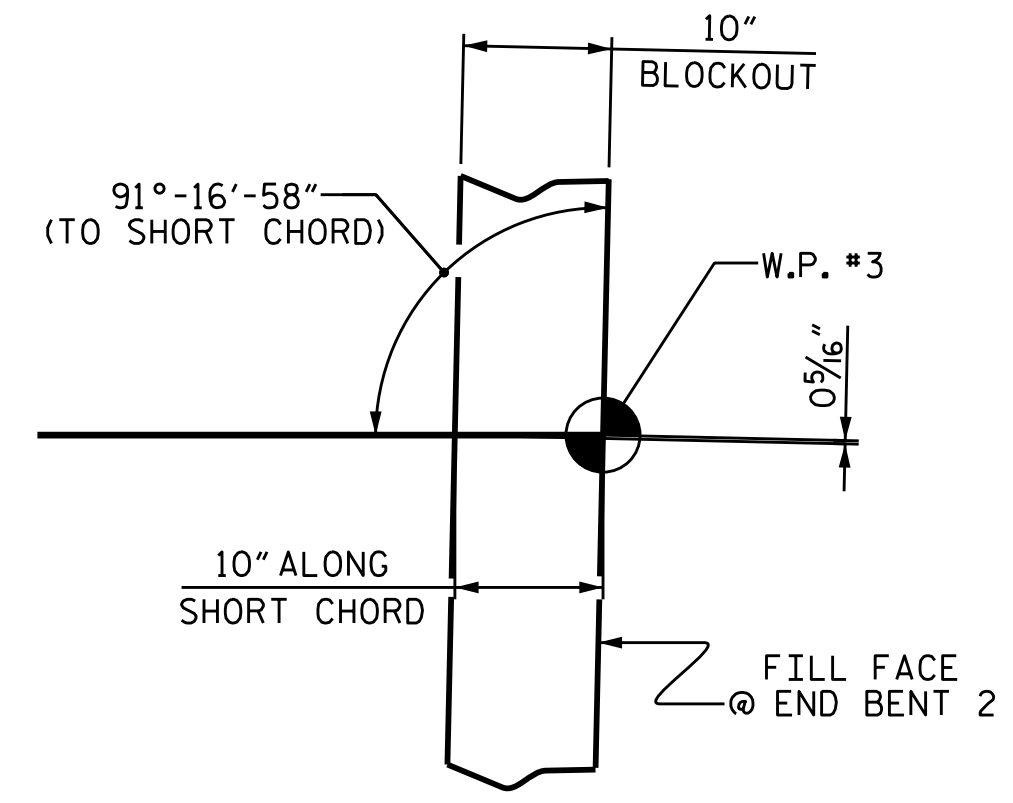

DETAIL "B"

PROJECT NO. U-2579C
 FORSYTH COUNTY
 STATION: 29+24.97 -Y1-

SHEET 2 OF 3

STATE OF NORTH CAROLINA
 DEPARTMENT OF TRANSPORTATION
 RALEIGH

SUPERSTRUCTURE
 PLAN OF SPAN B

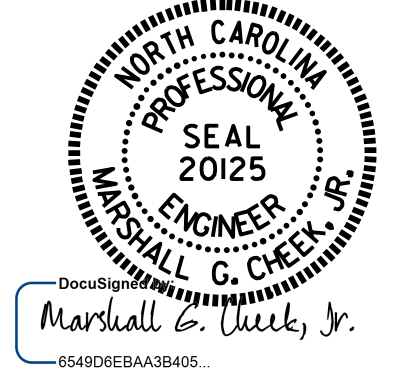

7/27/2017

DRAWN BY: J.P. MCCARTHA DATE: 4/29/16
 CHECKED BY: H.A. LOCKLEAR DATE: 8/25/16
 DESIGN ENGINEER OF RECORD: H.A. LOCKLEAR DATE: 6/2017

DOCUMENT NOT CONSIDERED FINAL UNLESS ALL SIGNATURES COMPLETED

REVISIONS						SHEET NO.
NO.	BY:	DATE:	NO.	BY:	DATE:	S1-9
1			3			TOTAL SHEETS
2			4			32

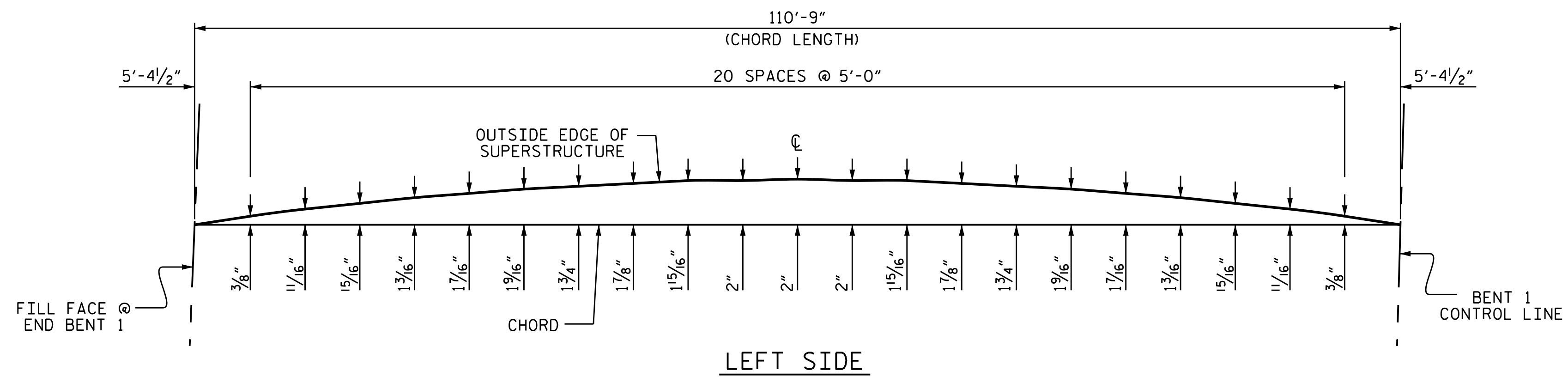

LEFT SIDE

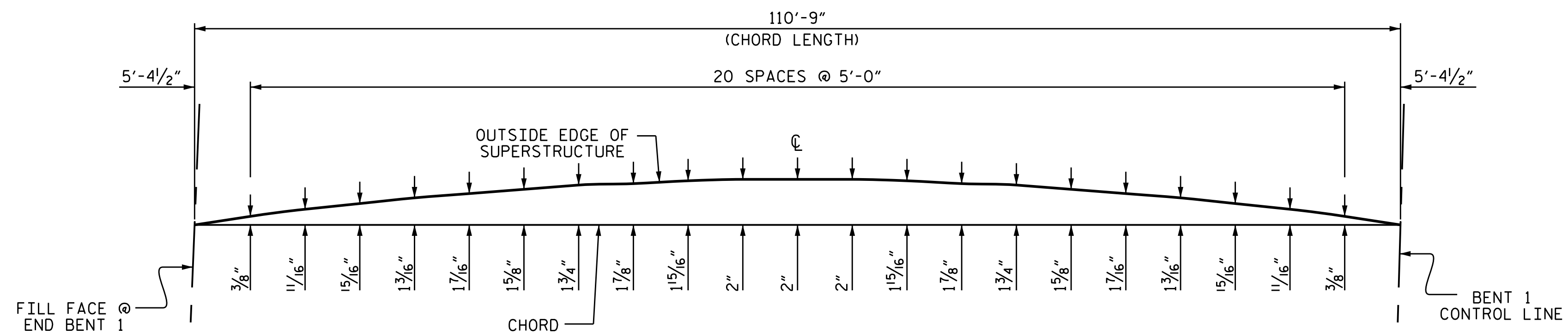

RIGHT SIDE

SPAN A ARC OFFSETS

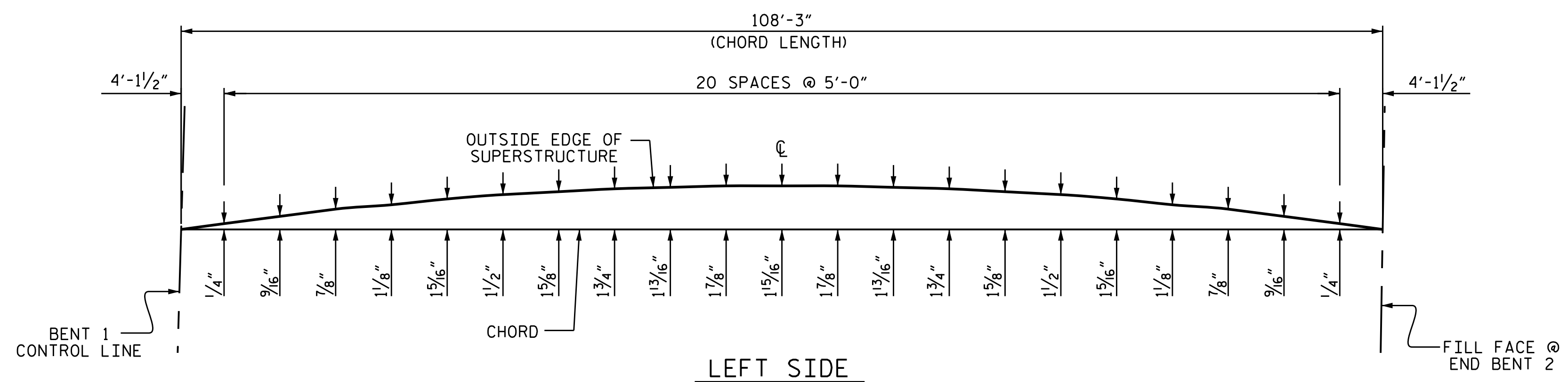

LEFT SIDE

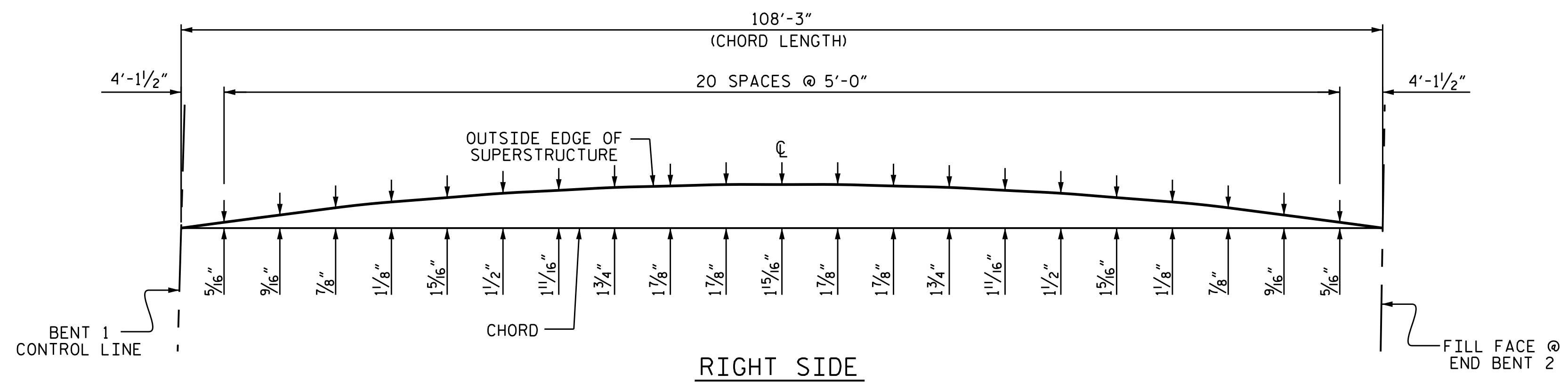

RIGHT SIDE

SPAN B ARC OFFSETS

PROJECT NO. U-2579C
FORSYTH COUNTY
 STATION: 29+24.97 -Y1-
 SHEET 3 OF 3

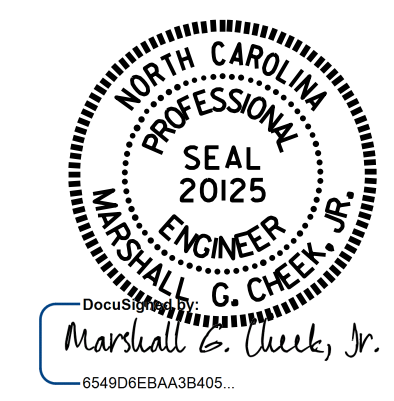

STATE OF NORTH CAROLINA
 DEPARTMENT OF TRANSPORTATION
 RALEIGH
 SUPERSTRUCTURE
 ARC OFFSETS

DRAWN BY : J. P. MCCARTHA DATE : 4/25/16
 CHECKED BY : H.A. LOCKLEAR DATE : 8/25/16
 DESIGN ENGINEER OF RECORD: H.A. LOCKLEAR DATE : 6/2017

DOCUMENT NOT CONSIDERED
 FINAL UNLESS ALL
 SIGNATURES COMPLETED

REVISIONS						SHEET NO.
NO.	BY:	DATE:	NO.	BY:	DATE:	TOTAL SHEETS
1			3			S1-10
2			4			32

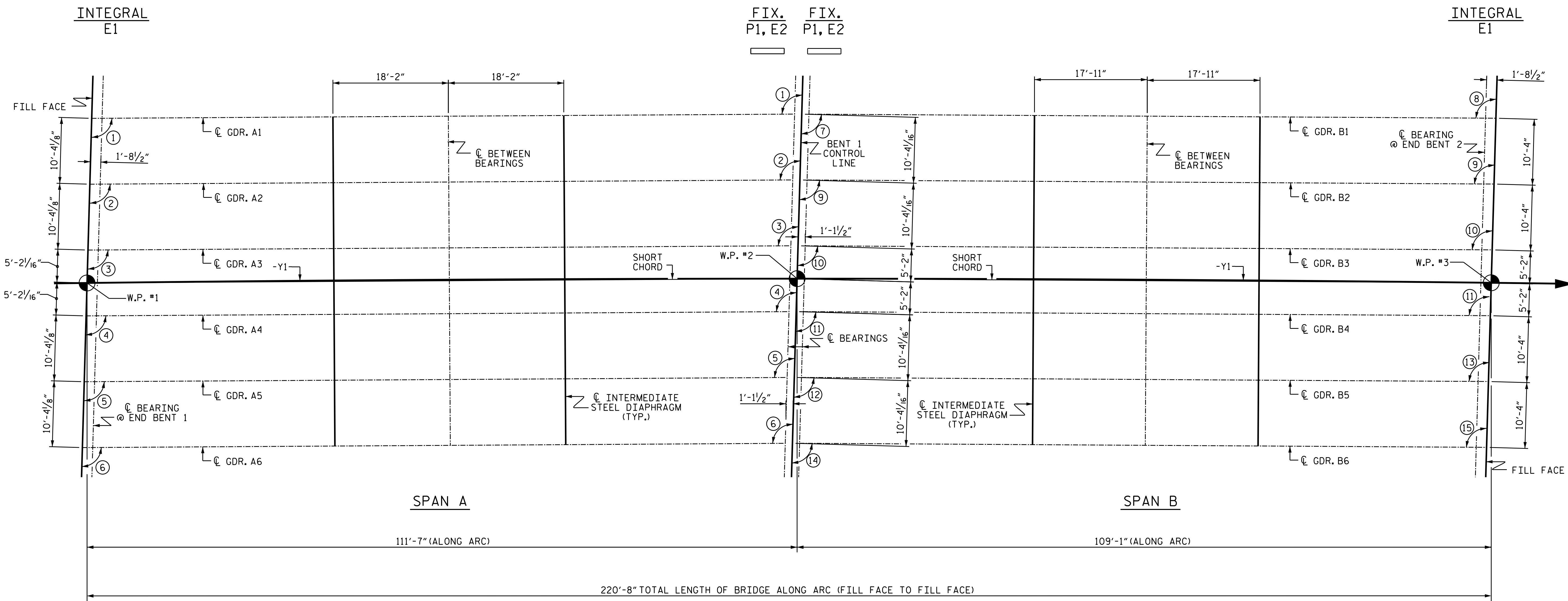

FRAMING PLAN

ANGLE TO GIRDER SHORT CHORD

1	91°-57'-56"	9	91°-16'-51"
2	91°-58'-04"	10	91°-16'-56"
3	91°-58'-12"	11	91°-17'-01"
4	91°-58'-20"	12	91°-17'-06"
5	91°-58'-28"	13	91°-17'-07"
6	91°-58'-36"	14	91°-17'-11"
7	91°-16'-45"	15	91°-17'-12"
8	91°-16'-46"		

PROJECT NO. U-2579C
 FORSYTH COUNTY
 STATION: 29+24+97 -Y1-

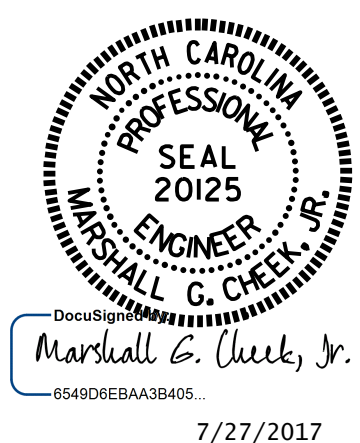

STATE OF NORTH CAROLINA
 DEPARTMENT OF TRANSPORTATION
 RALEIGH
 SUPERSTRUCTURE
 FRAMING PLAN

DRAWN BY : J.P. MCCARTHA DATE : 4/20/16
 CHECKED BY : H.A. LOCKLEAR DATE : 8/25/16
 DESIGN ENGINEER OF RECORD : H.A. LOCKLEAR DATE : 6/2017

DOCUMENT NOT CONSIDERED
 FINAL UNLESS ALL
 SIGNATURES COMPLETED

REVISIONS						SHEET NO.	
NO.	BY:	DATE:	NO.	BY:	DATE:	S1-11	
1			3			TOTAL SHEETS	
2			4			32	

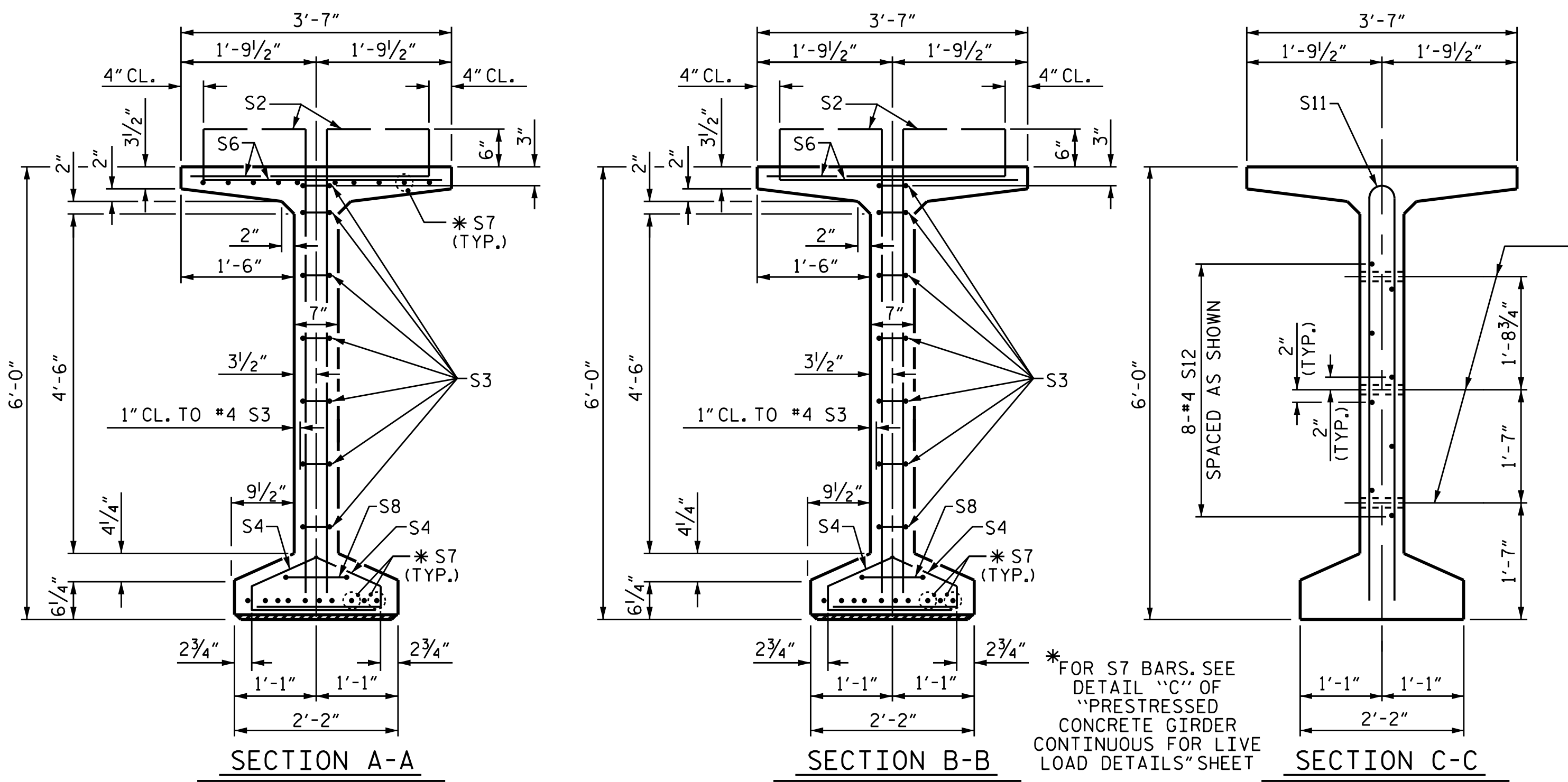

1/2" Ø FORMED HOLE.
(SEE "FRAMING PLAN" SHEET FOR LOCATION)

* FOR S7 BARS, SEE
DETAIL "C" OF
"PRESTRESSED
CONCRETE GIRDER
CONTINUOUS FOR LIVE
LOAD DETAILS" SHEET

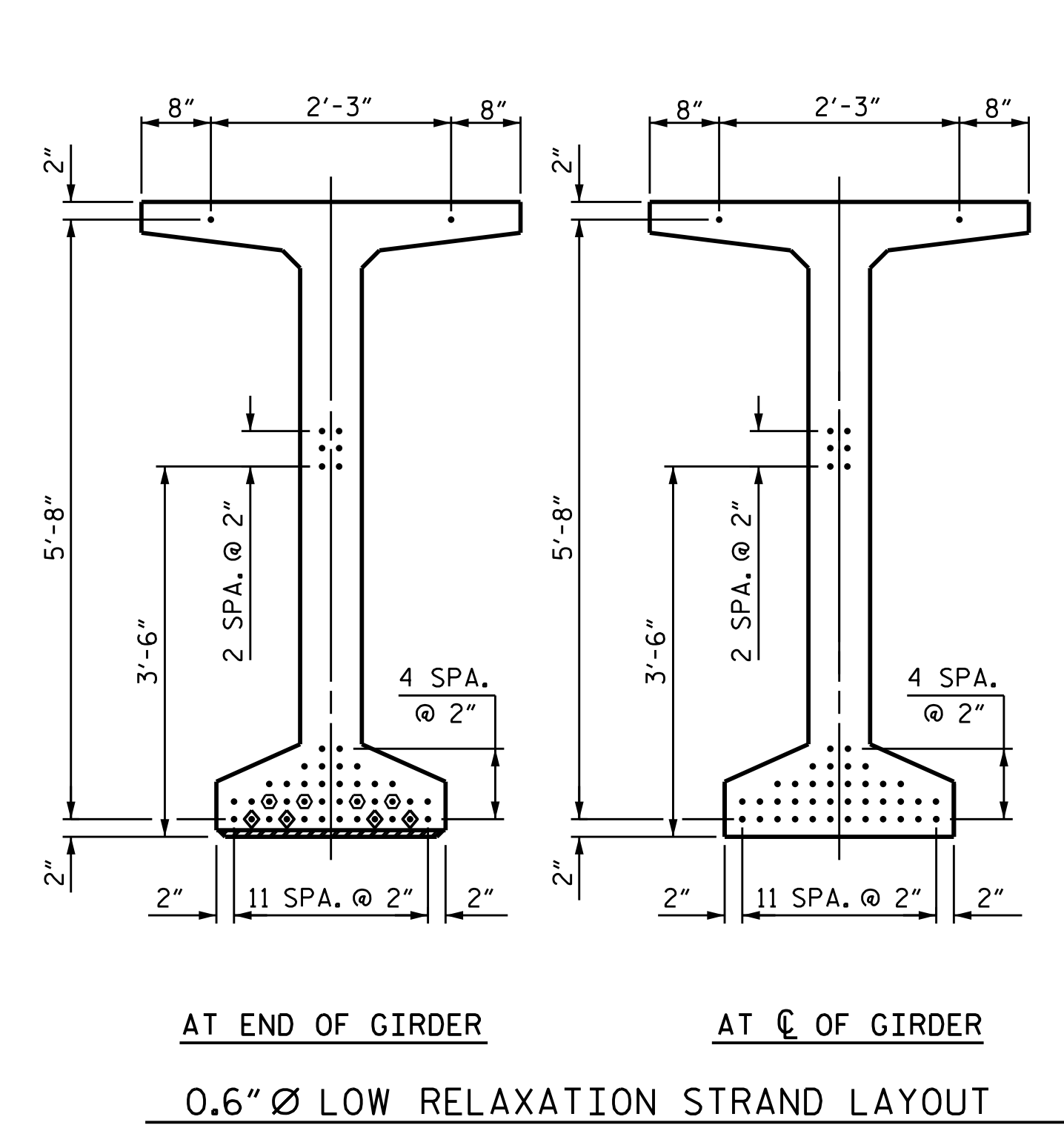

0.6" Ø L. R. GRADE 270 STRANDS		
AREA (SQUARE INCHES)	ULTIMATE STRENGTH (LBS. PER STRAND)	APPLIED PRESTRESS (LBS. PER STRAND)
0.217	58,600	43,950

REINFORCING STEEL FOR ONE GDR					
BAR	NUMBER	SIZE	TYPE	LENGTH	WEIGHT
S1	178	#4	1	6'-10"	813
S2	32	#5	1	6'-10"	228
S3	14	#4	2	8'-5"	79
S4	92	#4	3	3'-0"	184
S6	210	#5	4	4'-4"	949
* S7	30	#5	STR	3'-8"	115
S8	2	#5	2	9'-0"	19
S9	32	#5	STR	3'-3"	108
S10	2	#3	STR	1'-10"	1
S11	8	#5	5	11'-6"	96
S12	16	#4	STR	8'-0"	86

* NOTE: S7 BARS SHALL BE BENT BEFORE SHIPMENT. HEAT BENDING SHALL NOT BE ALLOWED.

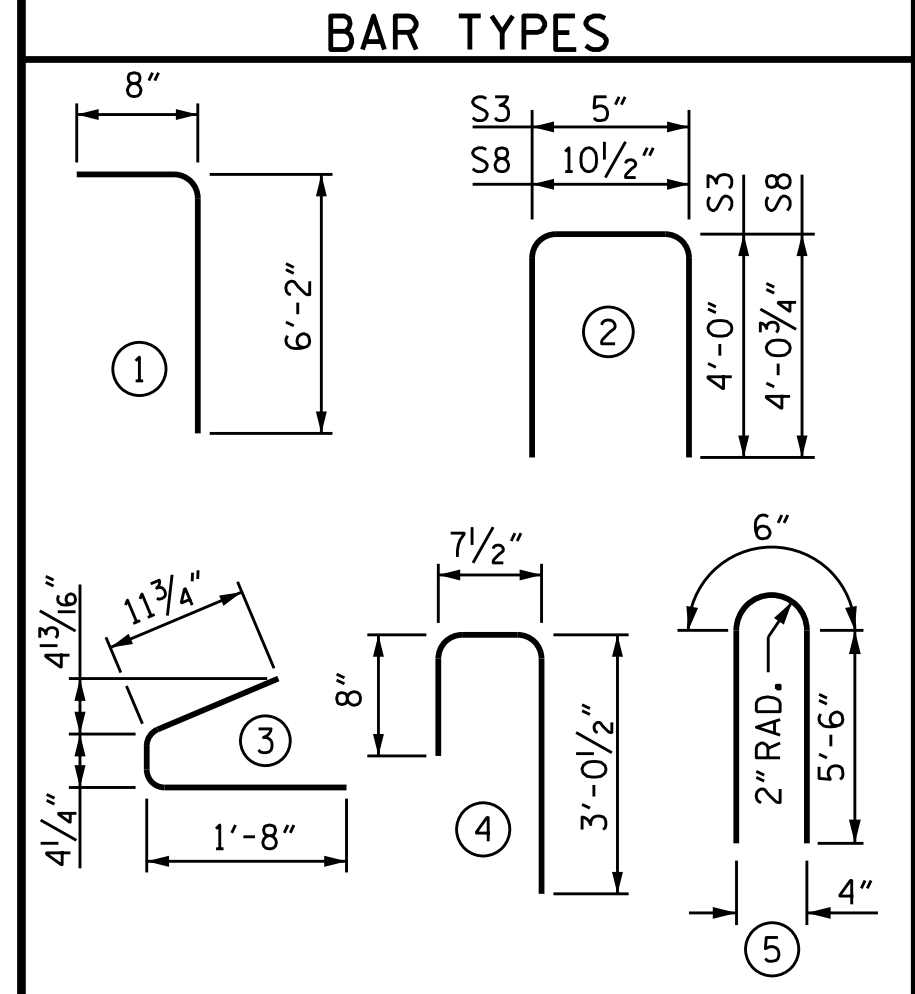

ALL BAR DIMENSIONS ARE OUT TO OUT

QUANTITIES FOR ONE GIRDER			
REINFORCING STEEL	9,500 PSI CONCRETE	0.6" Ø L.R. STRANDS	
LBS.	C.Y.	No.	
2678	23.6	46	

GIRDERS REQUIRED		
NUMBER	LENGTH	TOTAL LENGTH
6	110'-2"	661'-0"

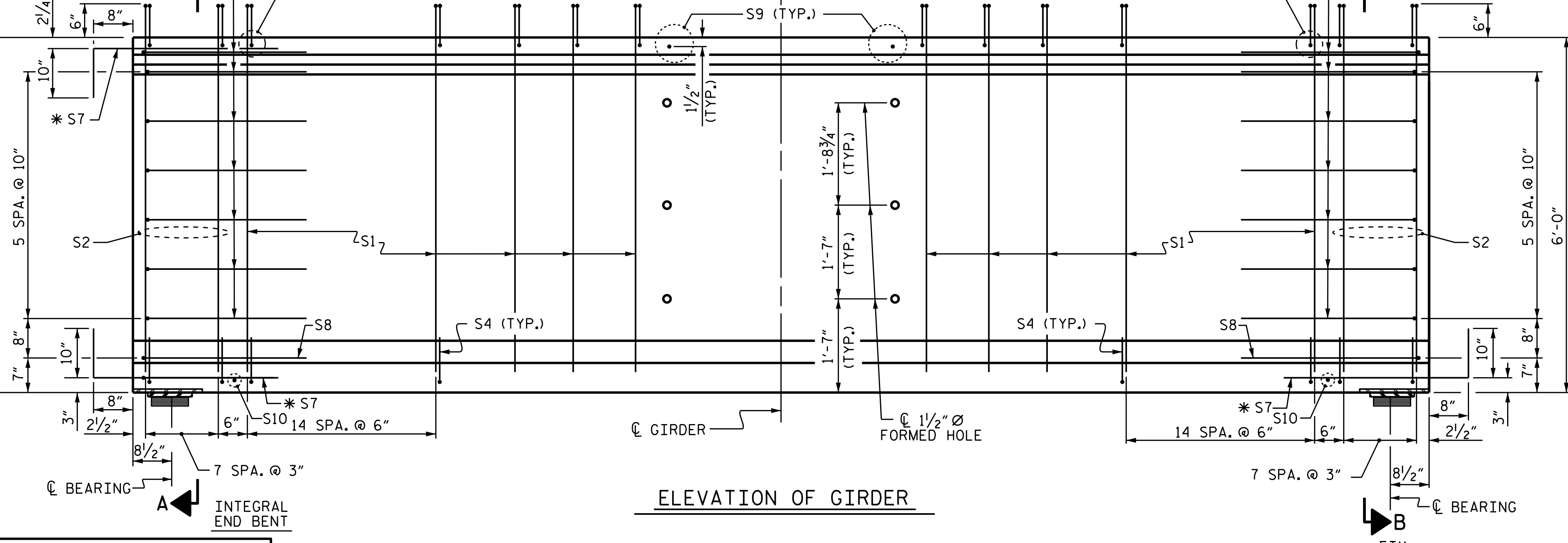
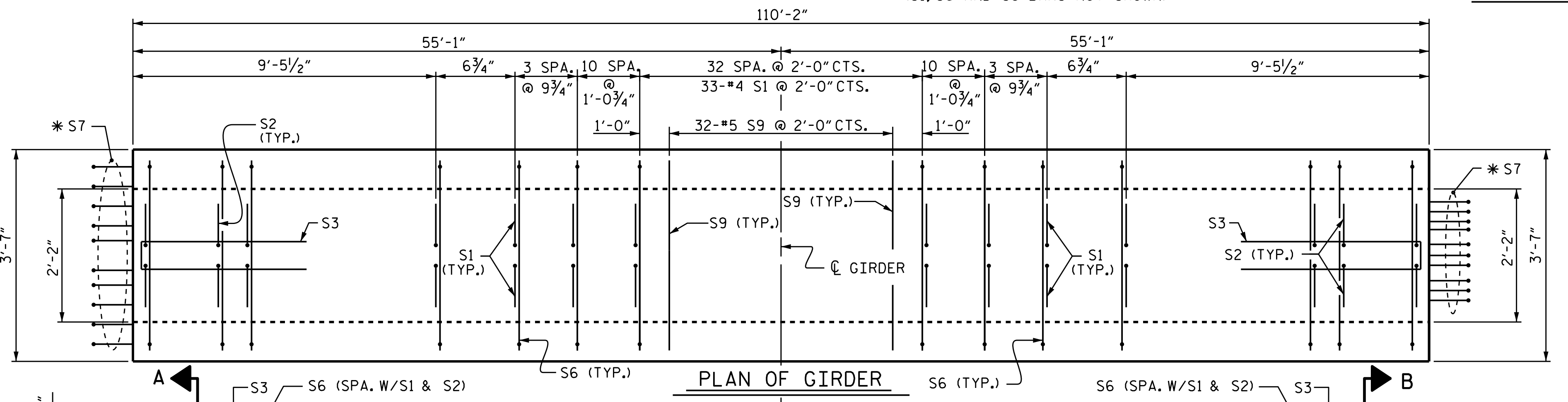

- DEBONDING LEGEND
- FULLY BONDED STRANDS
 - STRANDS DEBONDED FOR 10'-0" FROM END OF GIRDER
 - STRANDS DEBONDED FOR 12'-0" FROM END OF GIRDER

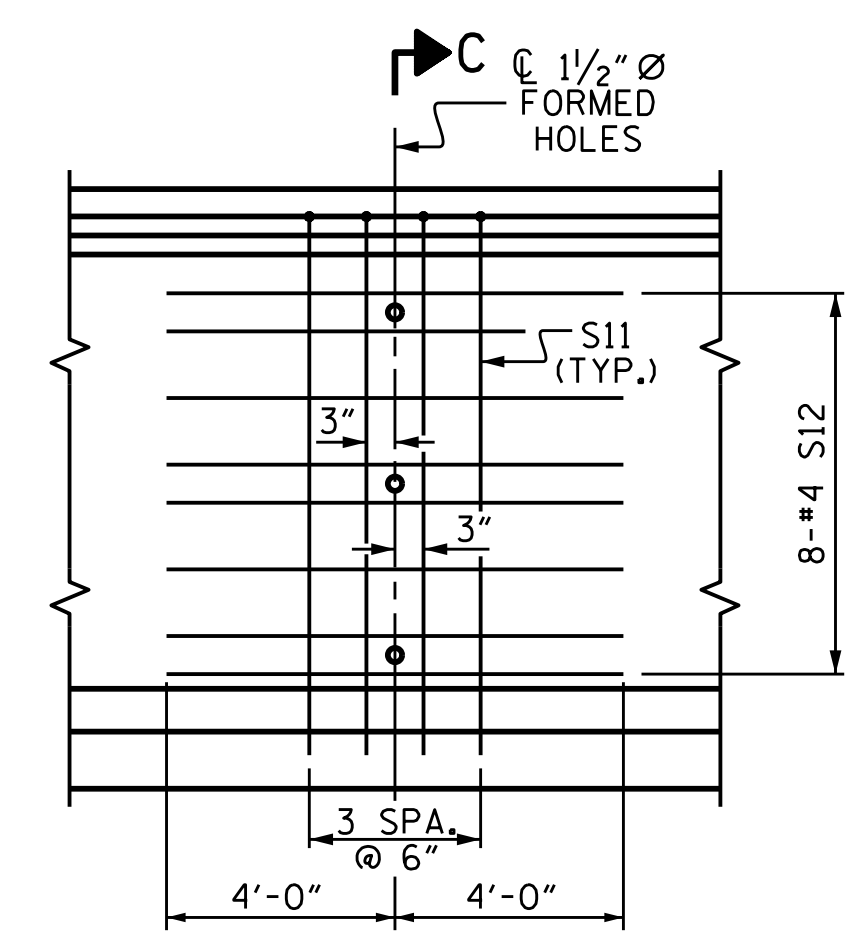

PARTIAL ELEVATION
SHOWING INTERMEDIATE STEEL DIAPHRAGM
REINFORCING STEEL FOR SPAN A GIRDERS
(2 LOCATIONS PER GIRDER)

PROJECT NO. U-2579C
FORSYTH COUNTY
STATION: 29+24.97 -Y1-

SHEET 1 OF 3
STATE OF NORTH CAROLINA
DEPARTMENT OF TRANSPORTATION
RALEIGH
STANDARD
72" PRESTRESSED CONCRETE
MODIFIED BULB TEE
CONTINUOUS FOR LIVE LOAD
SPAN A

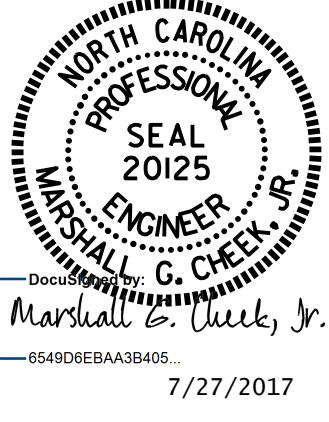

ASSEMBLED BY : J.P. MCCARTHA DATE : 5/2/16
CHECKED BY : H.A. LOCKLEAR DATE : 8/25/16
DRAWN BY : EEM 2/6/97
CHECKED BY : VAP 2/6/97

DESIGN ENGINEER OF RECORD:
H.A. LOCKLEAR DATE : 6/2017

DOCUMENT NOT CONSIDERED
FINAL UNLESS ALL
SIGNATURES COMPLETED

REVISIONS				SHEET NO.	
NO.	BY:	DATE:	NO.	BY:	DATE:
1			3		
2			4		

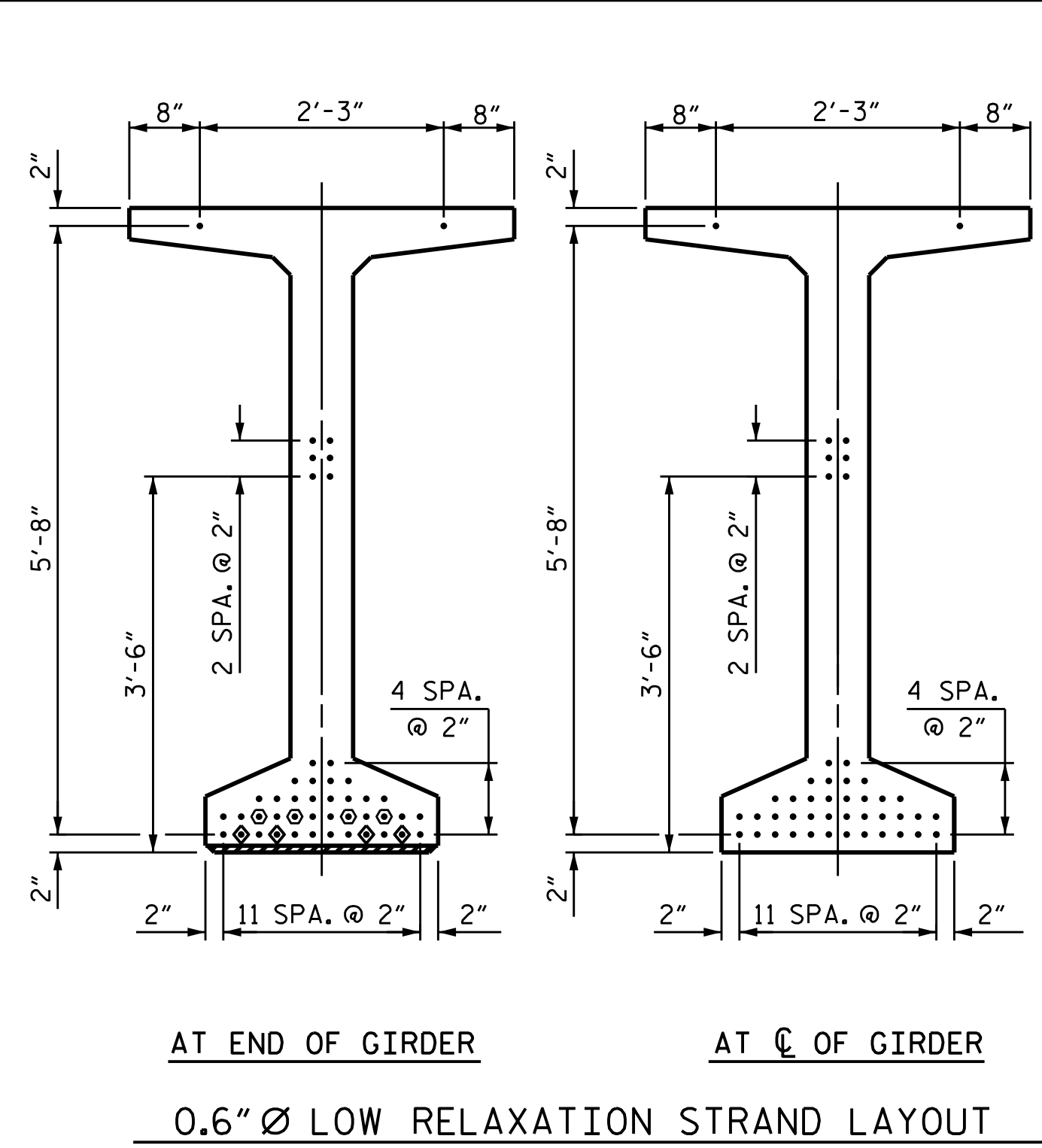
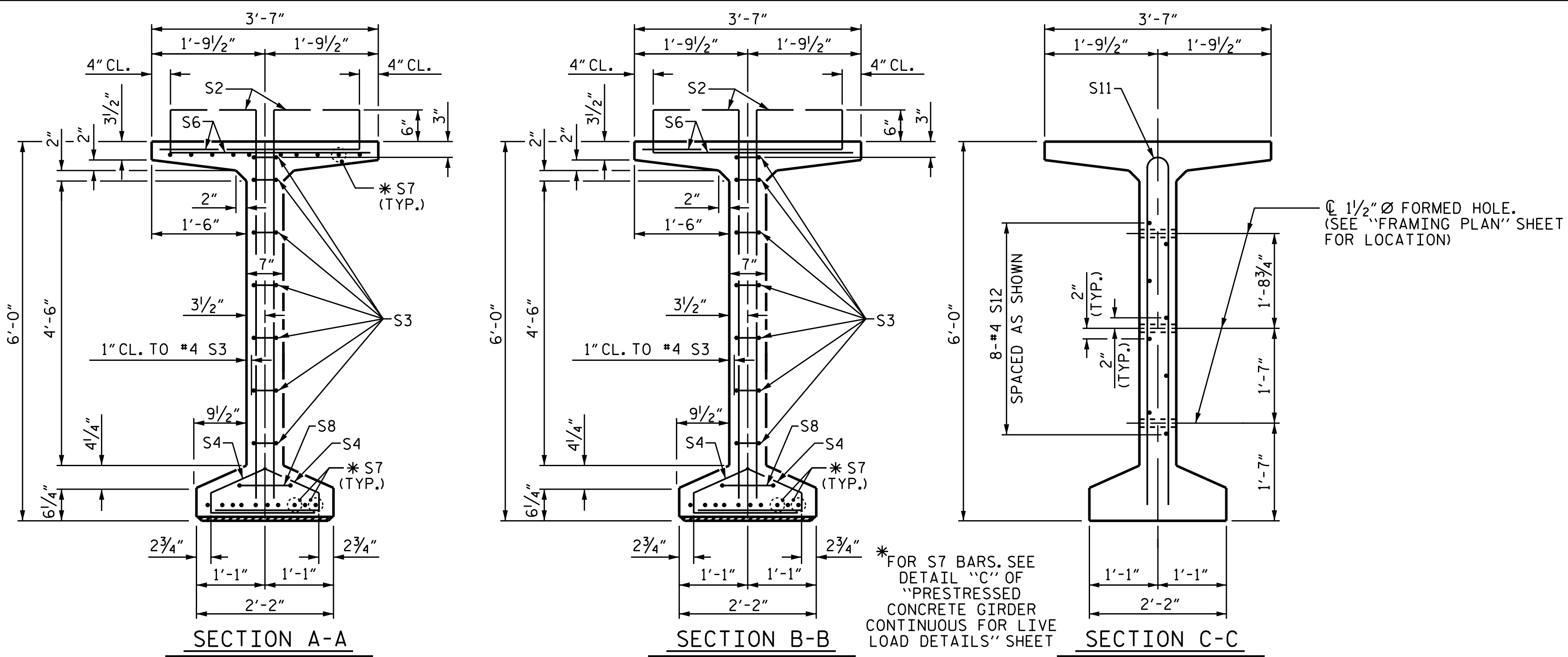

0.6" Ø L. R. GRADE 270 STRANDS

AREA (SQ. INCHES)	ULTIMATE STRENGTH (LBS. PER STRAND)	APPLIED PRESTRESS (LBS. PER STRAND)
0.217	58,600	43,950

REINFORCING STEEL FOR ONE GDR

BAR	NUMBER	SIZE	TYPE	LENGTH	WEIGHT
S1	170	#4	1	6'-10"	776
S2	32	#5	1	6'-10"	228
S3	14	#4	2	8'-5"	79
S4	92	#4	3	3'-0"	184
S6	202	#5	4	4'-4"	913
* S7	30	#5	STR	3'-8"	115
S8	2	#5	2	9'-0"	19
S9	30	#5	STR	3'-3"	102
S10	2	#3	STR	1'-10"	1
S11	8	#5	5	11'-6"	96
S12	16	#4	STR	8'-0"	86

* NOTE: S7 BARS SHALL BE BENT BEFORE SHIPMENT. HEAT BENDING SHALL NOT BE ALLOWED.

BAR TYPES

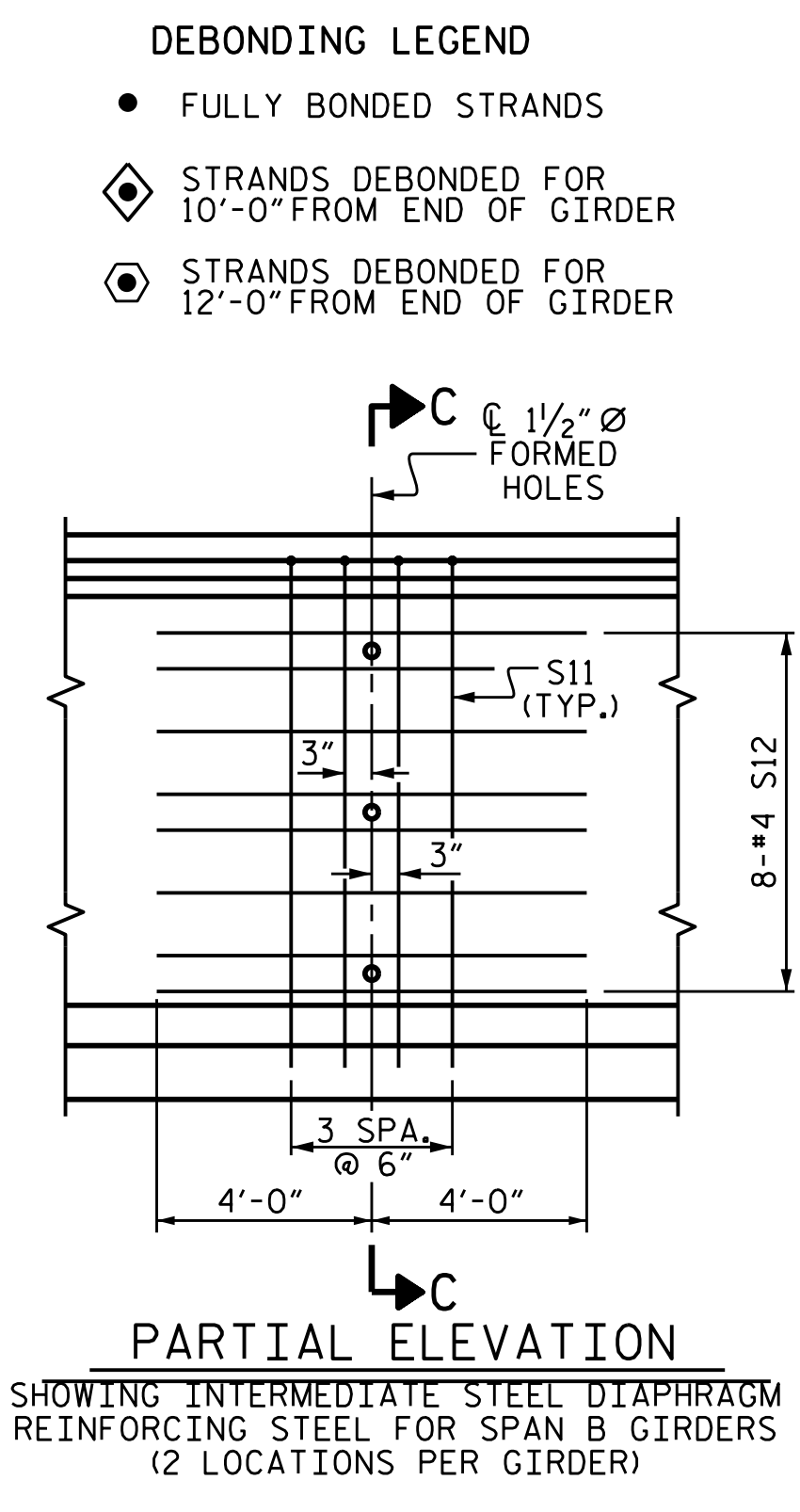
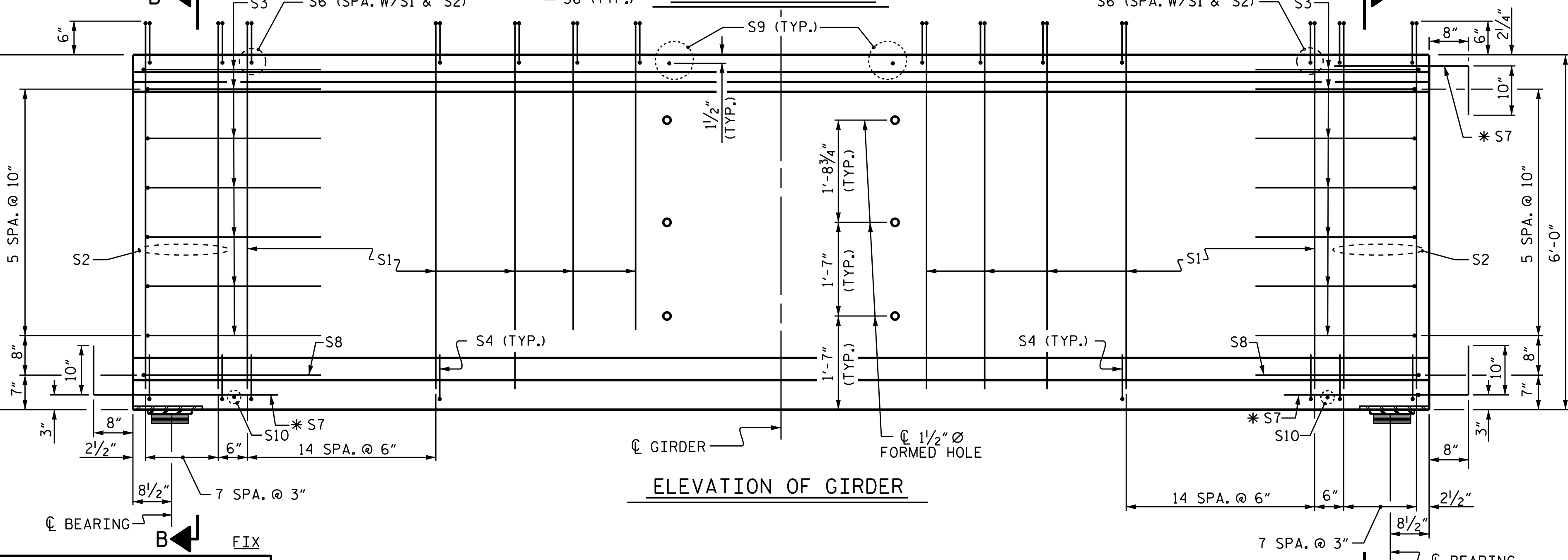
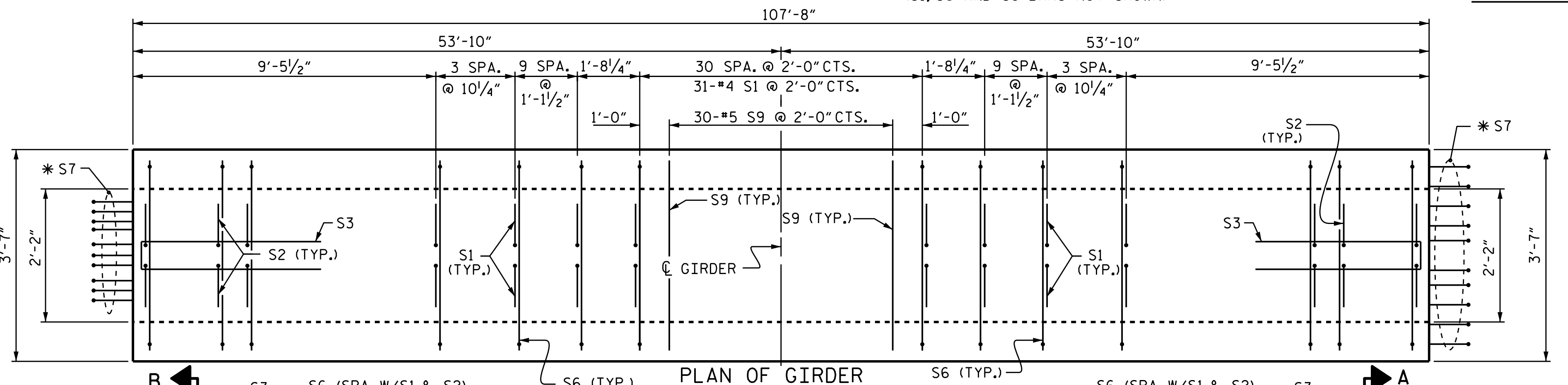

QUANTITIES FOR ONE GIRDER

REINFORCING STEEL	9,500 PSI CONCRETE	0.6" Ø L.R. STRANDS
LBS.	C.Y.	No.
2599	23.1	46

GIRDERS REQUIRED

NUMBER	LENGTH	TOTAL LENGTH
6	107'-8"	646'-0"

PROJECT NO. U-2579C
 FORSYTH COUNTY
 STATION: 29+24.97 -Y1-

SHEET 2 OF 3

STATE OF NORTH CAROLINA
 DEPARTMENT OF TRANSPORTATION
 RALEIGH

STANDARD
 72" PRESTRESSED CONCRETE
 MODIFIED BULB TEE
 CONTINUOUS FOR LIVE LOAD
 SPAN B

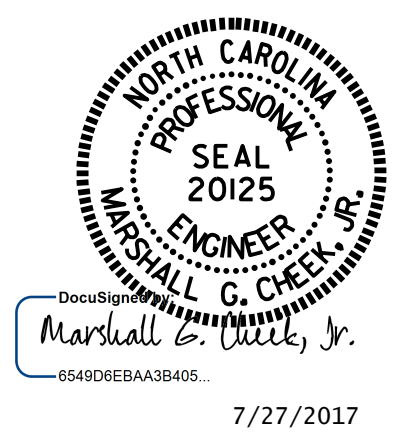

ASSEMBLED BY : J.P. MCCARTHA DATE : 5/3/16
 CHECKED BY : H.A. LOCKLEAR DATE : 8/25/16

DRAWN BY : EEM 2/6/97 MAA/GM
 CHECKED BY : VAP 2/6/97 REV. 6/13 MAA/GM
 REV. 1/15 MAA/TMG

DESIGN ENGINEER OF RECORD:
 H.A. LOCKLEAR DATE : 6/2017

DOCUMENT NOT CONSIDERED
 FINAL UNLESS ALL
 SIGNATURES COMPLETED

REVISIONS

NO.	BY:	DATE:	NO.	BY:	DATE:
1			3		
2			4		

SHEET NO. S1-13
 TOTAL SHEETS 32

DEAD LOAD DEFLECTION TABLE FOR GIRDERS

0.6" Ø LOW RELAXATION	SPAN A																					
	GIRDER A1																					
	℄ BRG.	0.05	0.10	0.15	0.20	0.25	0.30	0.35	0.40	0.45	0.50	0.55	0.60	0.65	0.70	0.75	0.80	0.85	0.90	0.95	℄ BRG.	
TWENTIETH POINTS	↑	0.000	0.037	0.073	0.107	0.138	0.166	0.189	0.208	0.221	0.229	0.232	0.229	0.221	0.208	0.189	0.166	0.138	0.107	0.073	0.037	0.000
* DEFLECTION DUE TO SUPERIMPOSED D.L.	↓	0.000	0.021	0.041	0.059	0.077	0.092	0.106	0.115	0.124	0.127	0.130	0.127	0.124	0.115	0.106	0.092	0.077	0.059	0.041	0.021	0.000
FINAL CAMBER	↑	0	3/16"	3/8"	9/16"	3/4"	7/8"	1"	1 1/8"	1 3/16"	1 1/4"	1 1/4"	1 1/4"	1 3/16"	1 1/8"	1"	7/8"	3/4"	9/16"	3/8"	3/16"	0

0.6" Ø LOW RELAXATION	SPAN A																					
	GIRDER A2 THRU A5																					
	℄ BRG.	0.05	0.10	0.15	0.20	0.25	0.30	0.35	0.40	0.45	0.50	0.55	0.60	0.65	0.70	0.75	0.80	0.85	0.90	0.95	℄ BRG.	
TWENTIETH POINTS	↑	0.000	0.037	0.073	0.107	0.138	0.166	0.189	0.208	0.221	0.229	0.232	0.229	0.221	0.208	0.189	0.166	0.138	0.107	0.073	0.037	0.000
* DEFLECTION DUE TO SUPERIMPOSED D.L.	↓	0.000	0.022	0.044	0.064	0.084	0.099	0.115	0.124	0.134	0.138	0.141	0.138	0.134	0.124	0.115	0.099	0.084	0.064	0.044	0.022	0.000
FINAL CAMBER	↑	0	3/16"	3/8"	1/2"	5/8"	13/16"	7/8"	1"	1 1/16"	1 1/8"	1 1/8"	1 1/8"	1 1/16"	1"	7/8"	13/16"	5/8"	1/2"	3/8"	3/16"	0

0.6" Ø LOW RELAXATION	SPAN A																					
	GIRDER A6																					
	℄ BRG.	0.05	0.10	0.15	0.20	0.25	0.30	0.35	0.40	0.45	0.50	0.55	0.60	0.65	0.70	0.75	0.80	0.85	0.90	0.95	℄ BRG.	
TWENTIETH POINTS	↑	0.000	0.037	0.073	0.107	0.138	0.166	0.189	0.208	0.221	0.229	0.232	0.229	0.221	0.208	0.189	0.166	0.138	0.107	0.073	0.037	0.000
* DEFLECTION DUE TO SUPERIMPOSED D.L.	↓	0.000	0.020	0.040	0.058	0.076	0.090	0.104	0.113	0.122	0.125	0.128	0.125	0.122	0.113	0.104	0.090	0.076	0.058	0.040	0.020	0.000
FINAL CAMBER	↑	0	3/16"	3/8"	9/16"	3/4"	15/16"	1"	1 1/8"	1 3/16"	1 1/4"	1 1/4"	1 1/4"	1 3/16"	1 1/8"	1"	15/16"	3/4"	9/16"	3/8"	3/16"	0

* INCLUDES FUTURE WEARING SURFACE. ALL VALUES ARE SHOWN IN FEET (DECIMAL FORM), EXCEPT "FINAL CAMBER", WHICH IS GIVEN IN INCHES (FRACTION FORM).

DEAD LOAD DEFLECTION TABLE FOR GIRDERS

0.6" Ø LOW RELAXATION	SPAN B																					
	GIRDER B1																					
	℄ BRG.	0.05	0.10	0.15	0.20	0.25	0.30	0.35	0.40	0.45	0.50	0.55	0.60	0.65	0.70	0.75	0.80	0.85	0.90	0.95	℄ BRG.	
TWENTIETH POINTS	↑	0.000	0.036	0.071	0.104	0.135	0.162	0.184	0.203	0.216	0.224	0.227	0.224	0.216	0.203	0.184	0.162	0.135	0.104	0.071	0.036	0.000
* DEFLECTION DUE TO SUPERIMPOSED D.L.	↓	0.000	0.019	0.037	0.054	0.071	0.084	0.097	0.105	0.113	0.116	0.119	0.116	0.113	0.105	0.097	0.084	0.071	0.054	0.037	0.019	0.000
FINAL CAMBER	↑	0	3/16"	7/16"	5/8"	3/4"	15/16"	1 1/16"	1 3/16"	1 1/4"	1 5/16"	1 5/16"	1 5/16"	1 1/4"	1 3/16"	1 1/16"	1 5/16"	3/4"	5/8"	7/16"	3/16"	0

0.6" Ø LOW RELAXATION	SPAN B																					
	GIRDER B2 THRU B5																					
	℄ BRG.	0.05	0.10	0.15	0.20	0.25	0.30	0.35	0.40	0.45	0.50	0.55	0.60	0.65	0.70	0.75	0.80	0.85	0.90	0.95	℄ BRG.	
TWENTIETH POINTS	↑	0.000	0.036	0.071	0.104	0.135	0.162	0.184	0.203	0.216	0.224	0.227	0.224	0.216	0.203	0.184	0.162	0.135	0.104	0.071	0.036	0.000
* DEFLECTION DUE TO SUPERIMPOSED D.L.	↓	0.000	0.020	0.040	0.058	0.076	0.090	0.104	0.113	0.122	0.125	0.128	0.125	0.122	0.113	0.104	0.090	0.076	0.058	0.040	0.020	0.000
FINAL CAMBER	↑	0	3/16"	3/8"	9/16"	1 1/16"	7/8"	15/16"	1 1/16"	1 1/8"	1 3/16"	1 3/16"	1 3/16"	1 1/8"	1 1/16"	1 5/16"	7/8"	1 1/16"	9/16"	3/8"	3/16"	0

0.6" Ø LOW RELAXATION	SPAN B																					
	GIRDER B6																					
	℄ BRG.	0.05	0.10	0.15	0.20	0.25	0.30	0.35	0.40	0.45	0.50	0.55	0.60	0.65	0.70	0.75	0.80	0.85	0.90	0.95	℄ BRG.	
TWENTIETH POINTS	↑	0.000	0.036	0.071	0.104	0.135	0.162	0.184	0.203	0.216	0.224	0.227	0.224	0.216	0.203	0.184	0.162	0.135	0.104	0.071	0.036	0.000
* DEFLECTION DUE TO SUPERIMPOSED D.L.	↓	0.000	0.018	0.037	0.053	0.069	0.082	0.095	0.103	0.111	0.114	0.117	0.114	0.111	0.103	0.095	0.082	0.069	0.053	0.036	0.018	0.000
FINAL CAMBER	↑	0	3/16"	7/16"	5/8"	13/16"	15/16"	1 1/16"	1 3/16"	1 1/4"	1 5/16"	1 5/16"	1 5/16"	1 1/4"	1 3/16"	1 1/16"	1 5/16"	13/16"	5/8"	7/16"	3/16"	0

* INCLUDES FUTURE WEARING SURFACE. ALL VALUES ARE SHOWN IN FEET (DECIMAL FORM), EXCEPT "FINAL CAMBER", WHICH IS GIVEN IN INCHES (FRACTION FORM).

NOTES

ALL PRESTRESSING STRANDS SHALL BE 7-WIRE LOW-RELAXATION GRADE 270 STRANDS AND SHALL CONFORM TO AASHTO M203 EXCEPT FOR SAMPLING REQUIREMENTS WHICH SHALL BE IN ACCORDANCE WITH THE STANDARD SPECIFICATIONS.

ALL REINFORCING STEEL SHALL BE GRADE 60.

EMBEDDED PLATE "B-1" SHALL BE GALVANIZED IN ACCORDANCE WITH THE STANDARD SPECIFICATIONS.

ANCHOR STUDS SHALL CONFORM TO AASHTO M169 GRADES 1010 THROUGH 1020 OR APPROVED EQUAL, AND SHALL MEET THE TYPE "B" REQUIREMENTS OF SUBSECTION 7.3 OF THE ANSI/AASHTO/AWS D1.5 BRIDGE WELDING CODE.

AT ENDS OF GIRDERS TO BE EMBEDDED IN CONCRETE DIAPHRAGMS OR END WALLS, PRESTRESSING STRANDS MAY EXTEND A MAXIMUM OF 2" BEYOND THE GIRDER ENDS. OTHERWISE, PRESTRESSING STRANDS SHALL BE CUT FLUSH WITH THE GIRDER ENDS.

THE TRANSFER OF LOAD FROM THE ANCHORAGES TO THE GIRDER SHALL BE DONE WHEN CONCRETE HAS REACHED A COMPRESSIVE STRENGTH OF NOT LESS THAN 7,600 PSI.

DEPENDING ON THE TYPE OF SYSTEM USED TO SUPPORT THE DECK SLAB FORMS, PRESET ANCHORS MAY BE NECESSARY IN THE PRESTRESSED CONCRETE GIRDER.

THE TOP SURFACE OF THE GIRDER, EXCLUDING THE OUTSIDE 4", SHALL BE RAKED TO A DEPTH OF 1/4".

A 2" x 2" CHAMFER IS ALLOWED AT THE INTERSECTION OF THE WEB AND THE BOTTOM FLANGE OF THE 72" MODIFIED BULB TEES ONLY.

FOR EMBEDDED CLIPS FOR PRESTRESSED CONCRETE GIRDERS, SEE SPECIAL PROVISIONS.

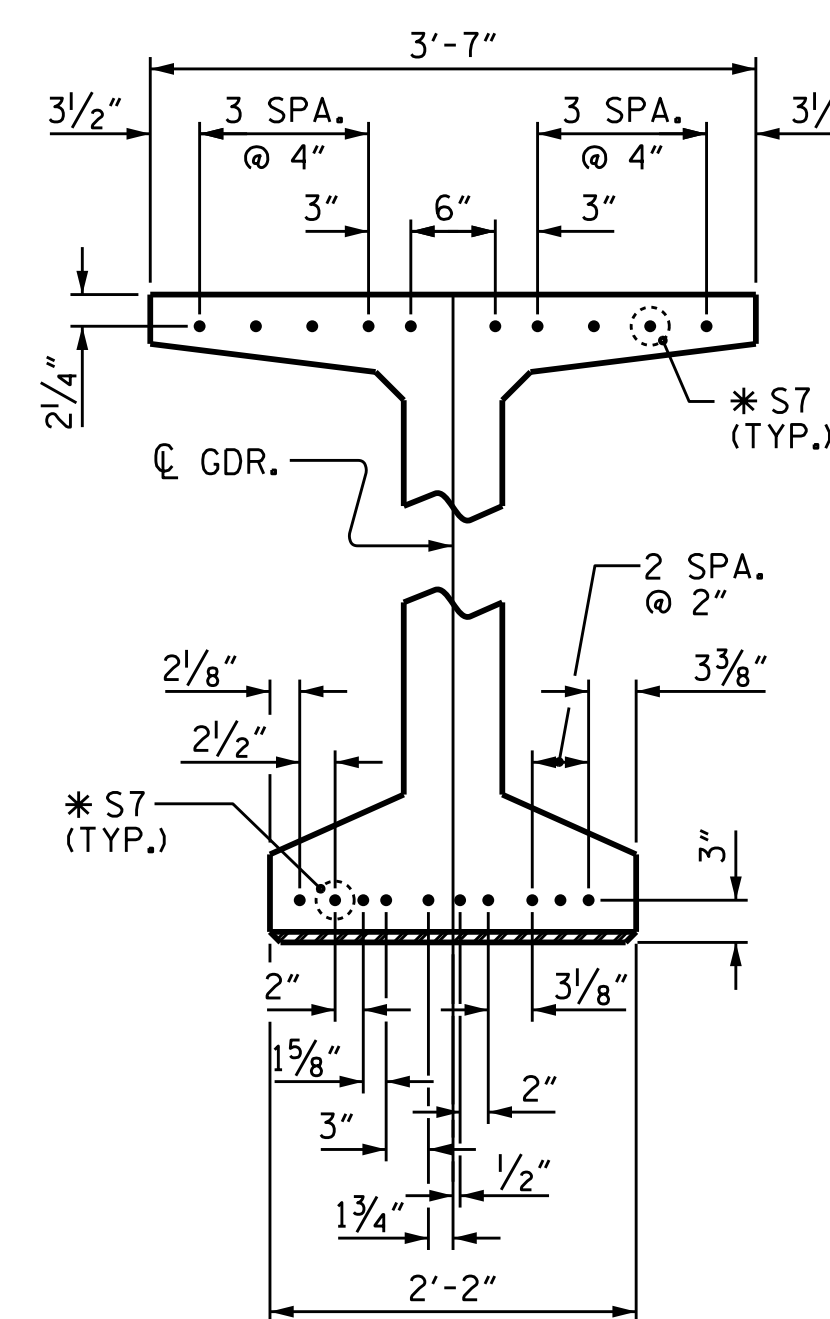
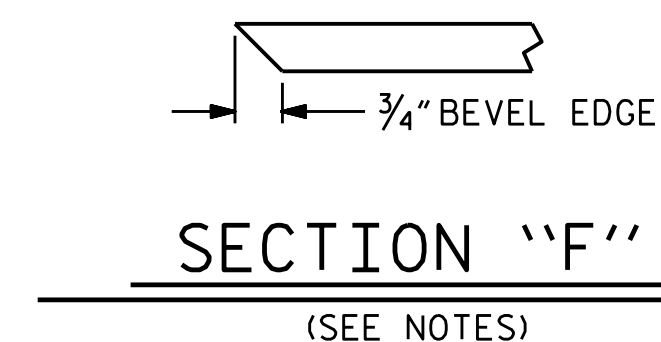

DETAIL "C"

* FOR S7 BARS, SEE DETAIL "C" OF PRESTRESSED CONCRETE GIRDER CONTINUOUS FOR LIVE LOAD DETAILS SHEET

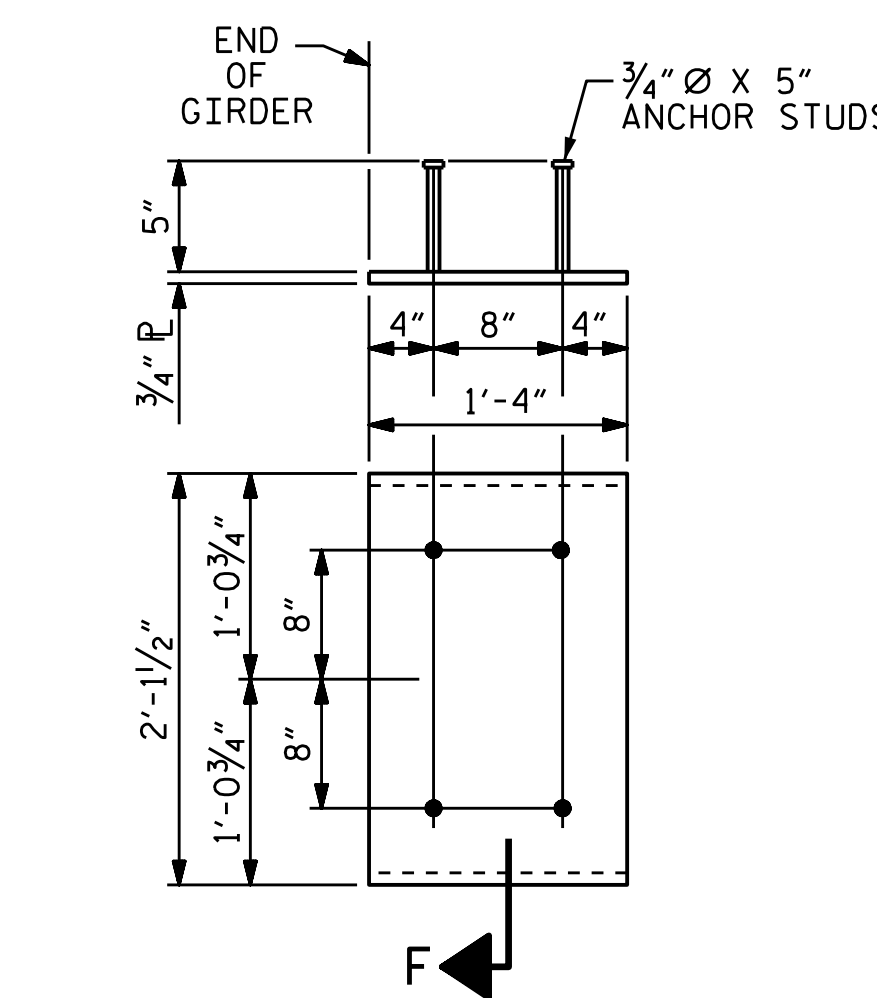
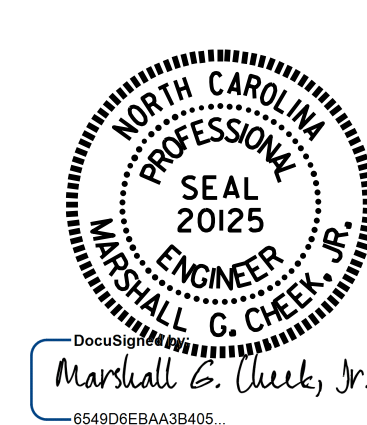

EMBEDDED PLATE "B-1" DETAILS FOR 72" MODIFIED BULB TEES
(2 REQ'D PER GIRDER)

PROJECT NO. U-2579C
FORSYTH COUNTY
STATION: 29+24.97 -Y1-

SHEET 3 OF 3

STATE OF NORTH CAROLINA
DEPARTMENT OF TRANSPORTATION
RALEIGH
STANDARD
PRESTRESSED CONCRETE GIRDER
CONTINUOUS FOR LIVE LOAD
DETAILS

ASSEMBLED BY : J. P. MCCARTHA DATE : 3/8/16
CHECKED BY : H.A. LOCKLEAR DATE : 8/26/16
DRAWN BY : ELR 11/91 REV. 10/1/11 MAA/GM
CHECKED BY : GRP 11/91 REV. 1/15 MAA/TMG
REV. 2/15 MAA/TMG

DOCUMENT NOT CONSIDERED FINAL UNLESS ALL SIGNATURES COMPLETED

REVISIONS					SHEET NO.
NO.	BY:	DATE:	NO.	BY:	DATE:
1			3		
2			4		

S1-14
TOTAL SHEETS
32

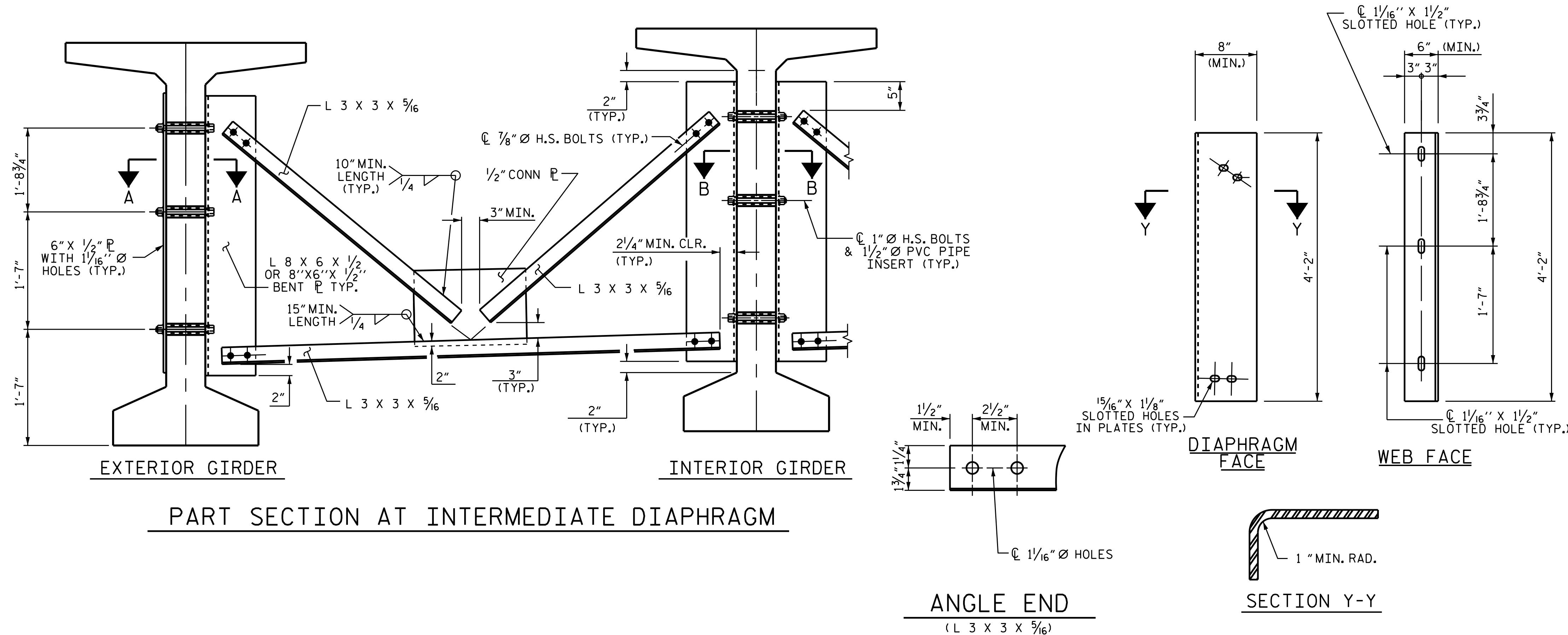

STRUCTURAL STEEL NOTES

ALL INTERMEDIATE DIAPHRAGM STEEL AND CONNECTOR PLATES SHALL BE AASHTO M270 GRADE 50 OR APPROVED EQUAL.

TENSION ON THE ASTM A325 BOLTS THROUGH THE ANGLE MEMBER SHALL BE CALIBRATED USING DIRECT TENSION INDICATOR (DTI) WASHERS IN ACCORDANCE WITH THE STANDARD SPECIFICATIONS.

TENSION ON THE ASTM A449 BOLTS THROUGH THE GIRDER WEB SHALL BE SNUG TIGHTENED FOLLOWED BY AN ADDITIONAL 1/4 TURN.

THE PLATES, BENT PLATES, AND ANGLES SHALL BE GALVANIZED OR METALLIZED IN ACCORDANCE WITH THE STANDARD SPECIFICATIONS. FOR THERMAL SPRAYED COATINGS (METALLIZATION), SEE SPECIAL PROVISIONS.

FOR METALLIZATION, APPLY AN 8 MIL THICK 99.99 PERCENT ZINC (W-Zn-1) THERMAL SPRAYED COATING WITH A 0.5 MIL THICK SEAL COAT TO ALL STEEL DIAPHRAGM SURFACES IN ACCORDANCE WITH THE THERMAL SPRAYED COATINGS SPECIAL PROVISION AND SECTION 442 OF THE STANDARD SPECIFICATIONS.

GALVANIZE THE HIGH STRENGTH BOLTS, NUTS, WASHERS AND DIRECT TENSION INDICATORS IN ACCORDANCE WITH THE STANDARD SPECIFICATIONS.

USE AN ASTM F436 HARDENED WASHER WITH STANDARD AND SLOTTED HOLES UNDER EACH BOLT HEAD AND NUT.

FOR BOLTS THROUGH THE GIRDER WEB, PROVIDE SUFFICIENT LENGTH OF THREADS ON ALL BOLTS TO ACCOMMODATE WASHERS AND THE THICKNESS OF CONNECTING MEMBER PLUS AT LEAST 1/4" PROJECTION BEYOND THE NUT.

INTERMEDIATE DIAPHRAGM ASSEMBLY SHALL COMPLY WITH SECTION 1072 OF THE STANDARD SPECIFICATIONS.

SUBMIT TWO SETS OF WORKING DRAWINGS FOR THE INTERMEDIATE DIAPHRAGM ASSEMBLY FOR REVIEW, COMMENTS AND ACCEPTANCE. AFTER REVIEW, COMMENTS, AND ACCEPTANCE, SUBMIT SEVEN SETS FOR DISTRIBUTION.

IN THE EXTERIOR BAYS, PLACE TEMPORARY STRUTS BETWEEN PRESTRESSED GIRDERS ADJACENT TO THE STEEL DIAPHRAGMS. STRUTS SHALL REMAIN IN PLACE 3 DAYS AFTER CONCRETE IS PLACED.

THE COST OF THE STEEL DIAPHRAGMS AND ASSEMBLIES SHALL BE INCLUDED IN THE UNIT PRICE BID FOR MODIFIED 72" PRESTRESSED CONCRETE GIRDERS.

CONNECTOR PLATE DETAIL

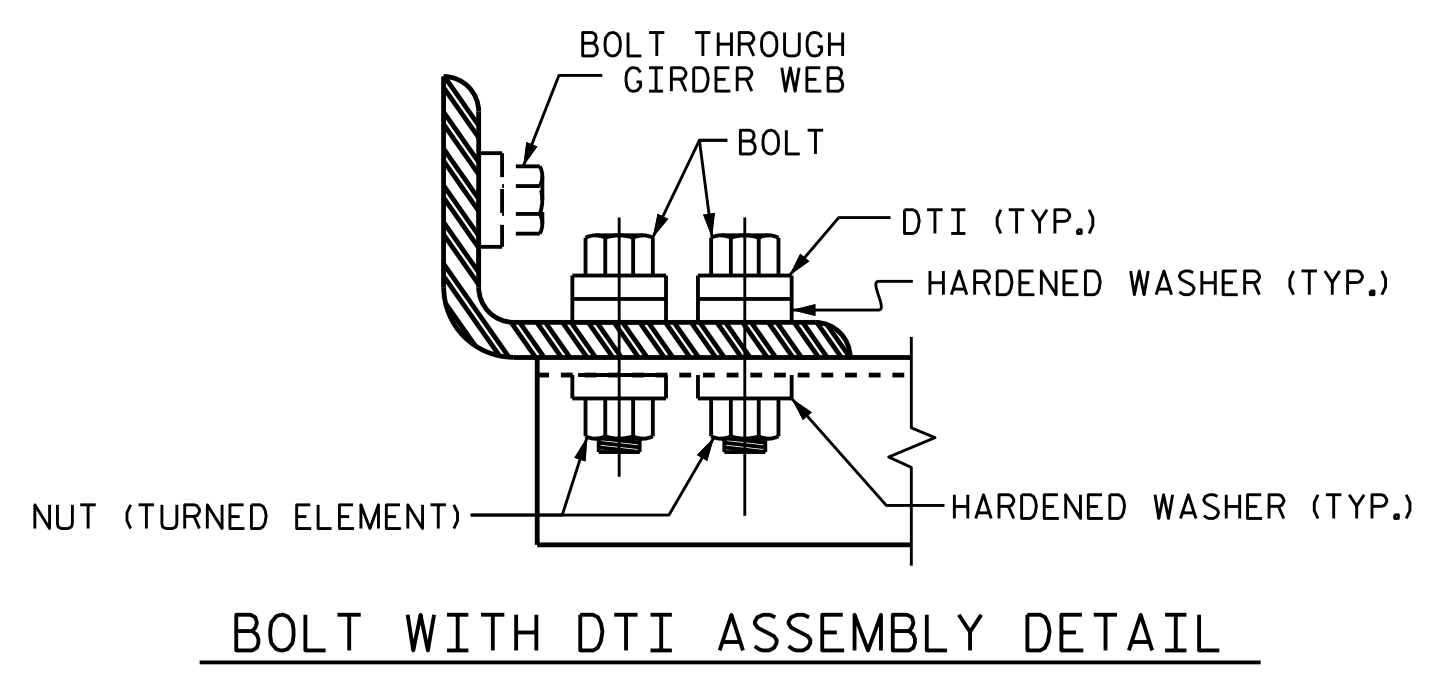
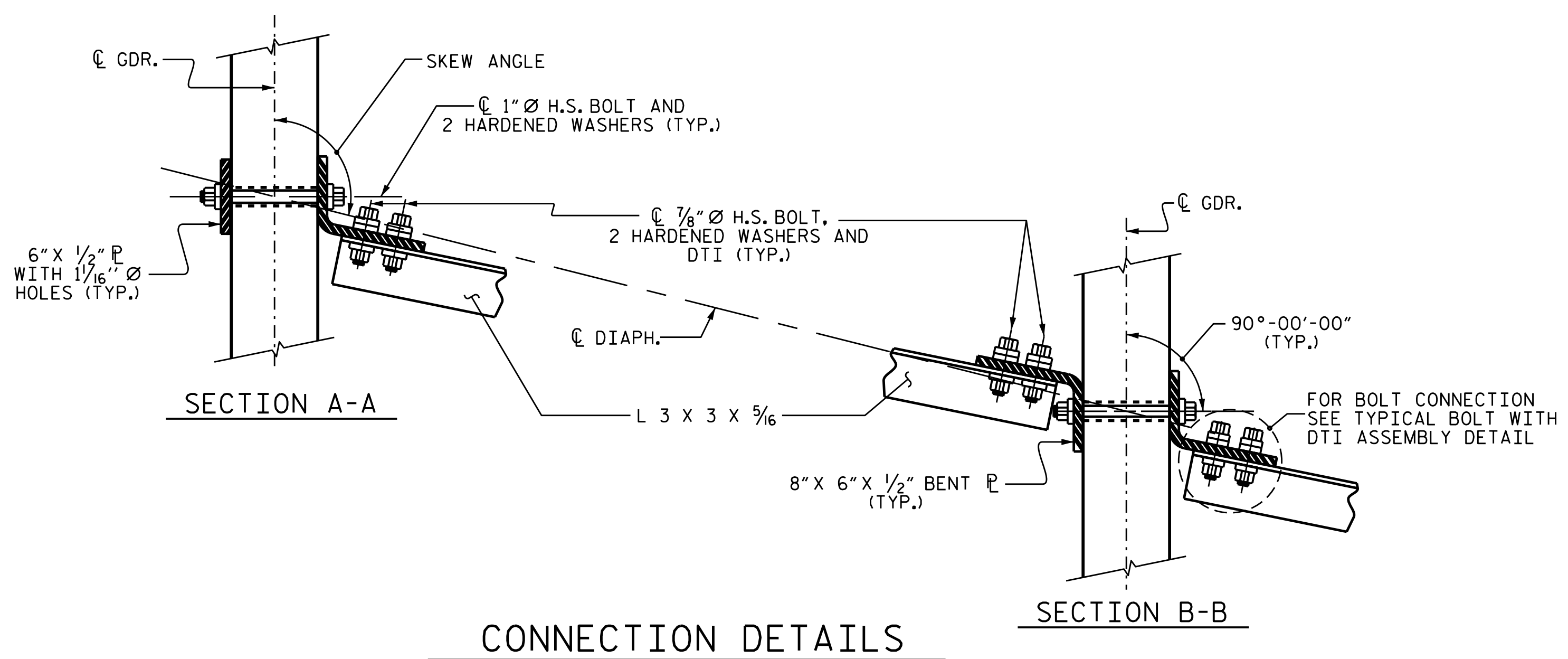

PROJECT NO. U-2579C
 FORSYTH COUNTY
 STATION: 29+24.97 -Y1-



STATE OF NORTH CAROLINA
 DEPARTMENT OF TRANSPORTATION
 RALEIGH
 STANDARD
 INTERMEDIATE STEEL
 DIAPHRAGMS FOR 72"
 MODIFIED BULB TEE
 PRESTRESSED CONCRETE
 GIRDERS

ASSEMBLED BY : J.P. MCCARTHA	DATE : 1/14/16
CHECKED BY : H.A. LOCKLEAR	DATE : 8/26/16
DRAWN BY : RWW 11/09	ADDED 11/23/09R
CHECKED BY : GM 11/09	REV. 10/11/11

REVISIONS						SHEET NO.	
NO.	BY:	DATE:	NO.	BY:	DATE:	S1-15	
1			3			TOTAL SHEETS	
2			4			32	

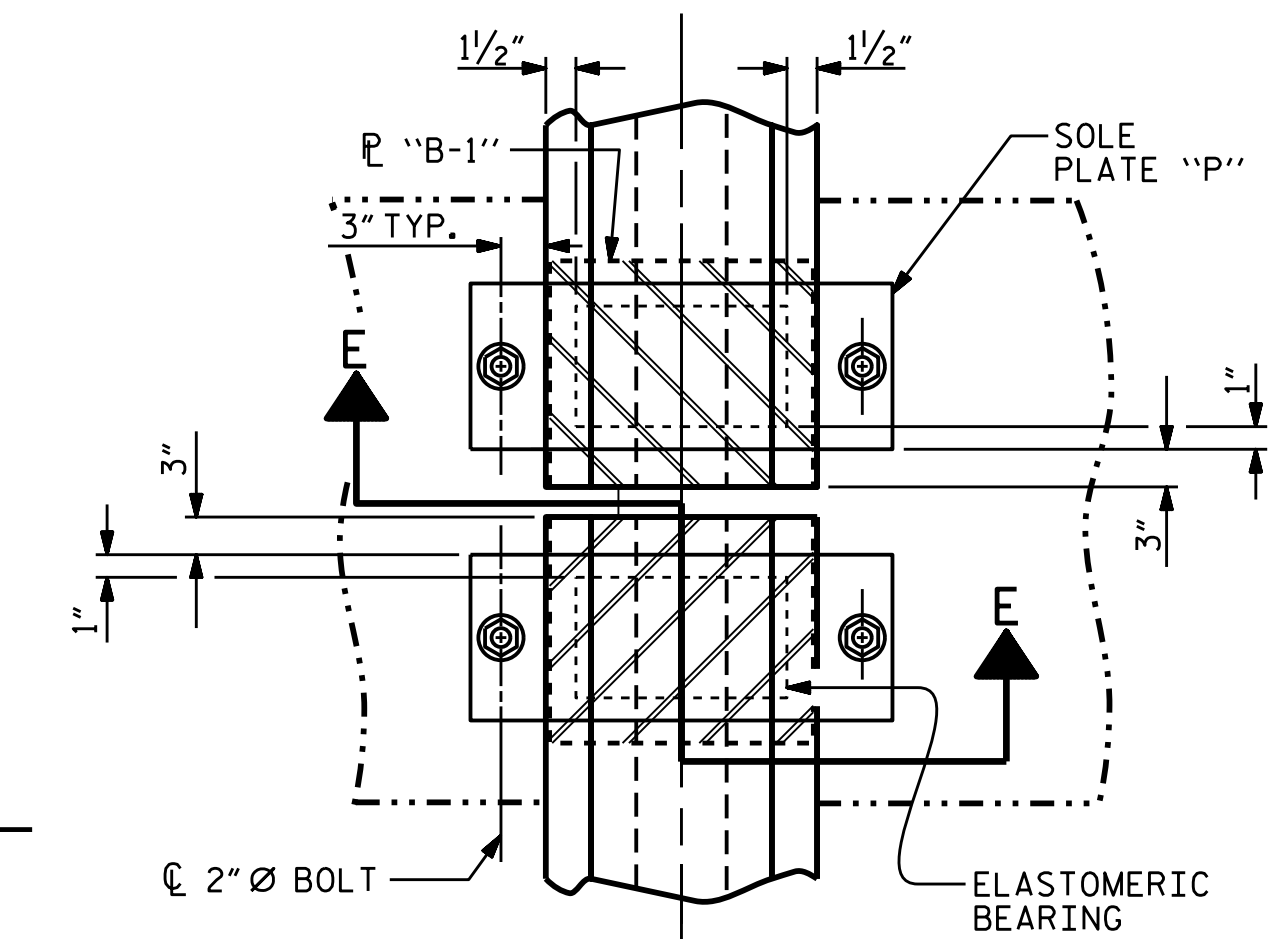
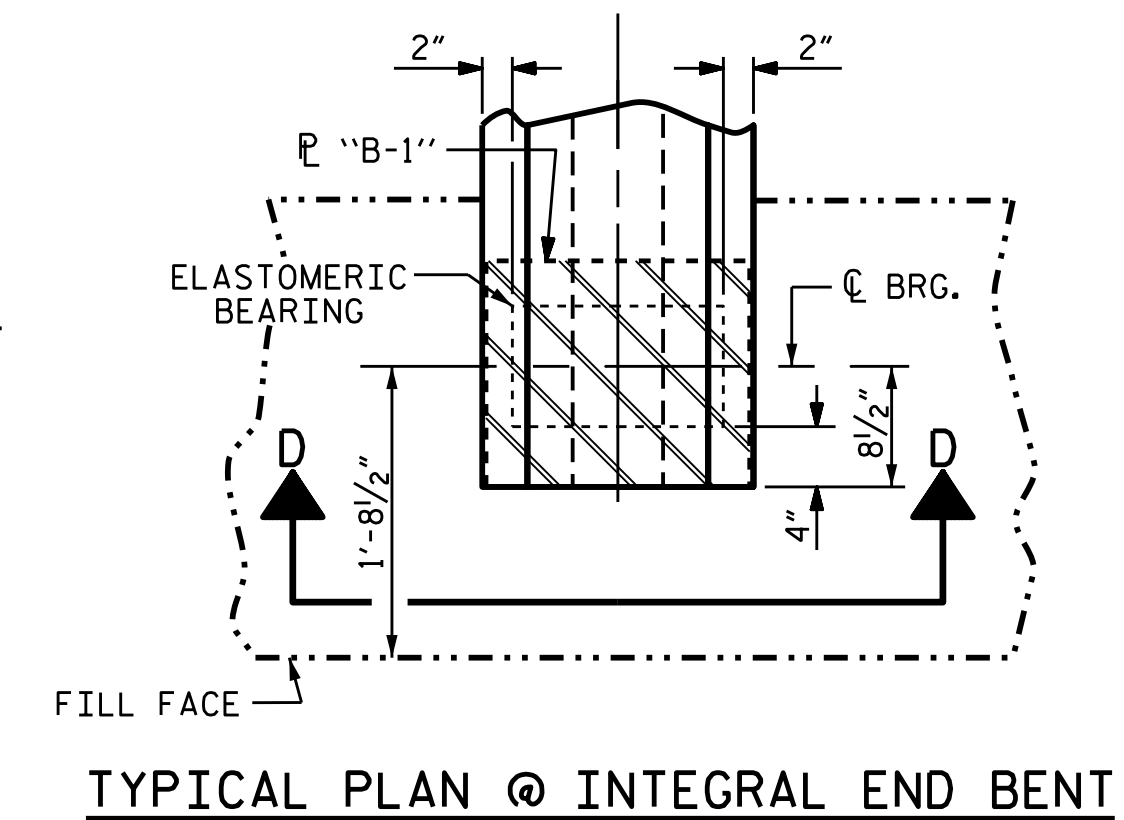
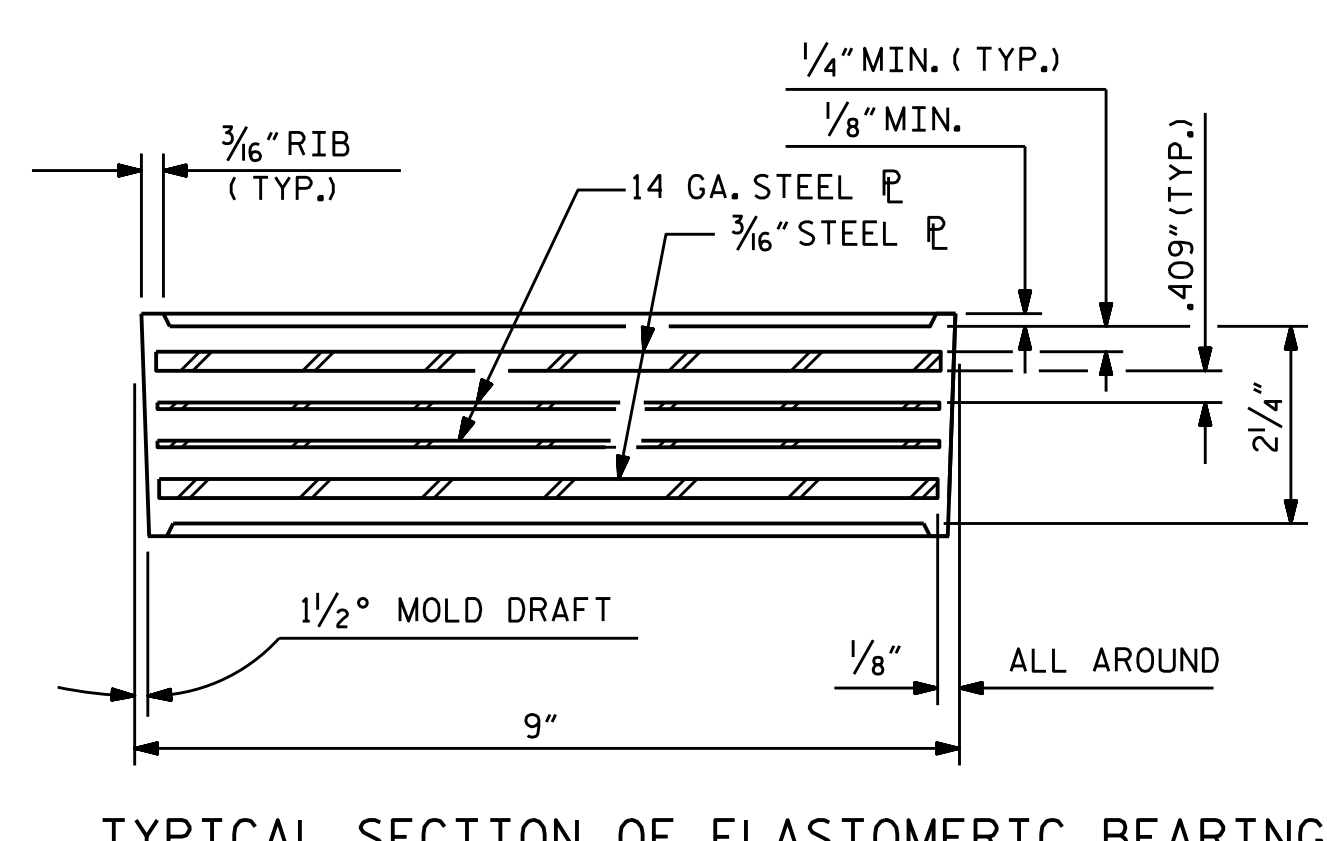
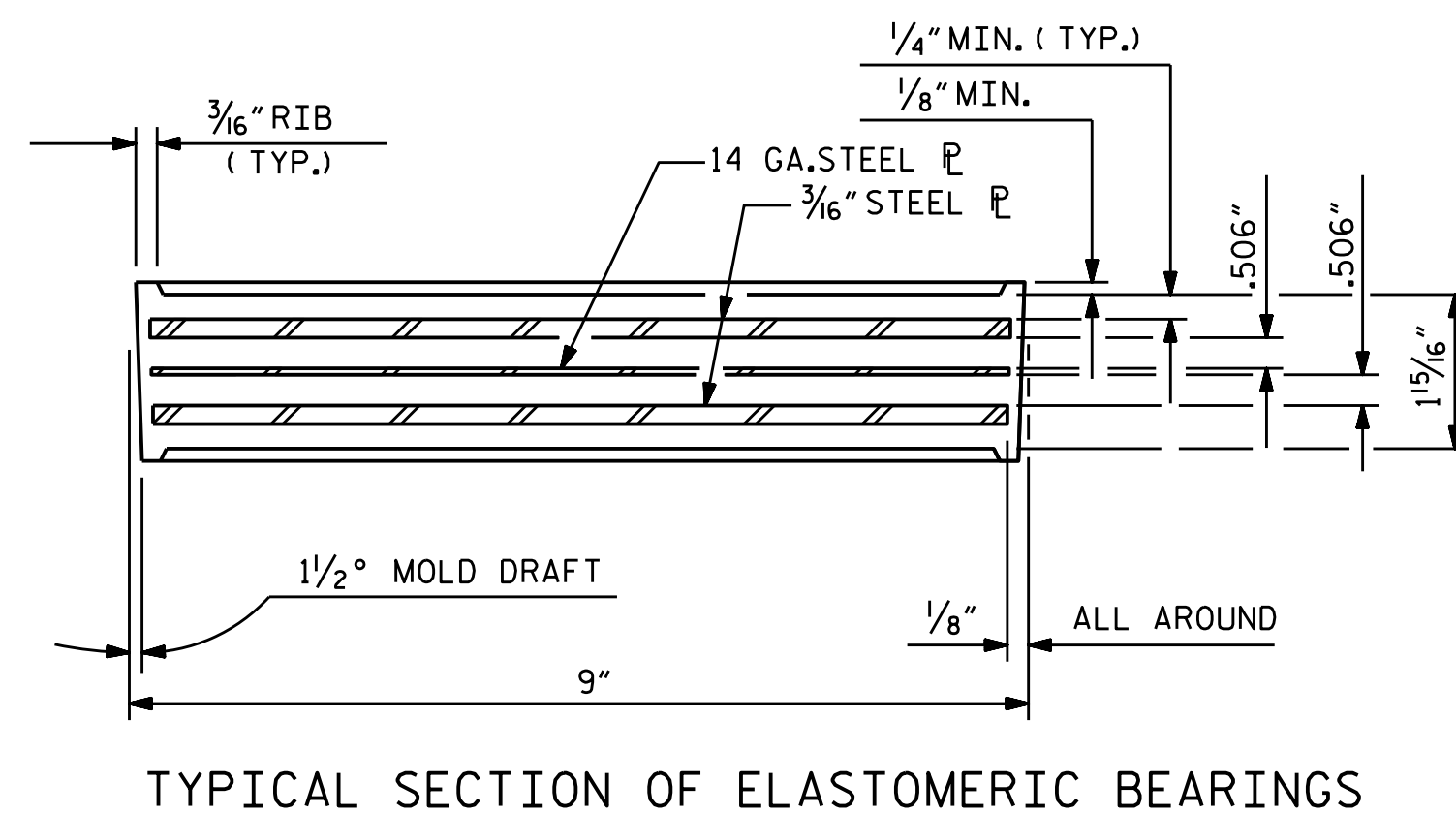
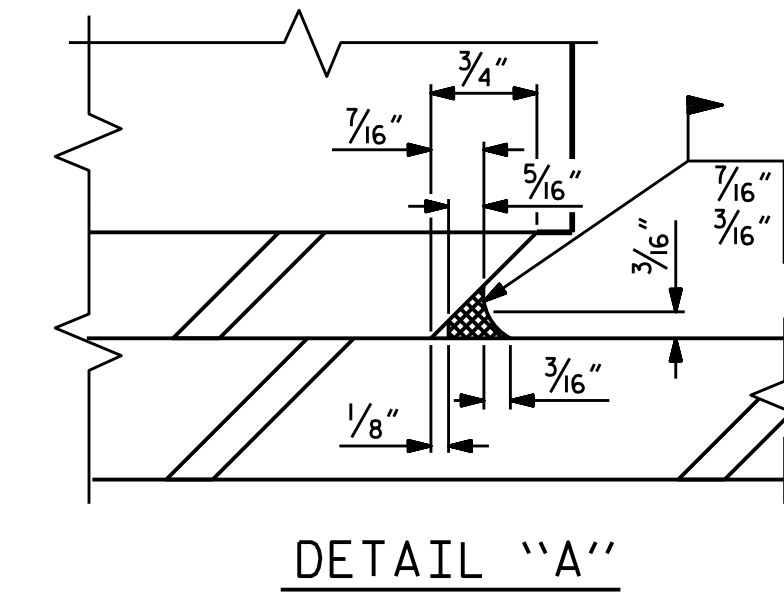
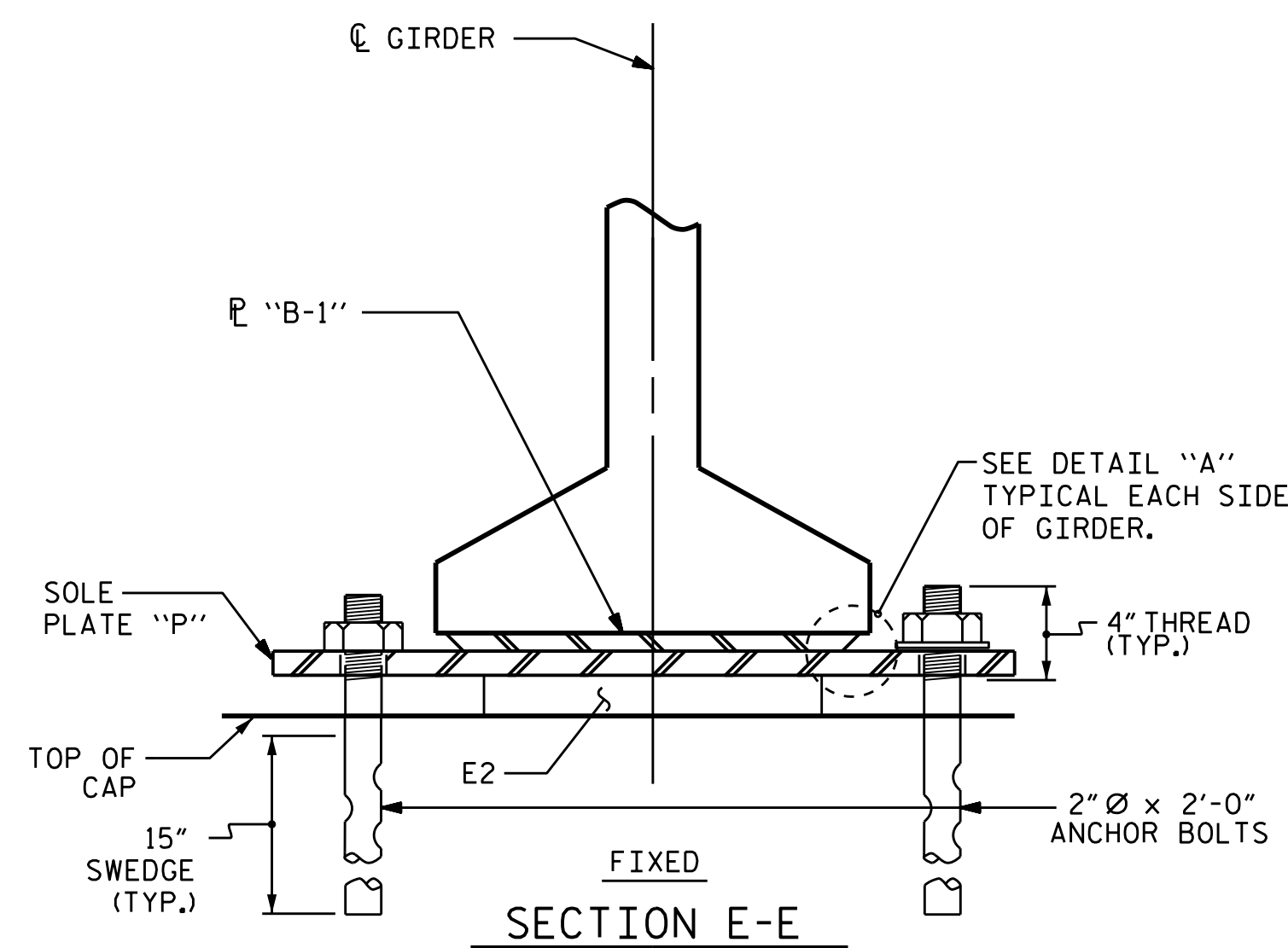
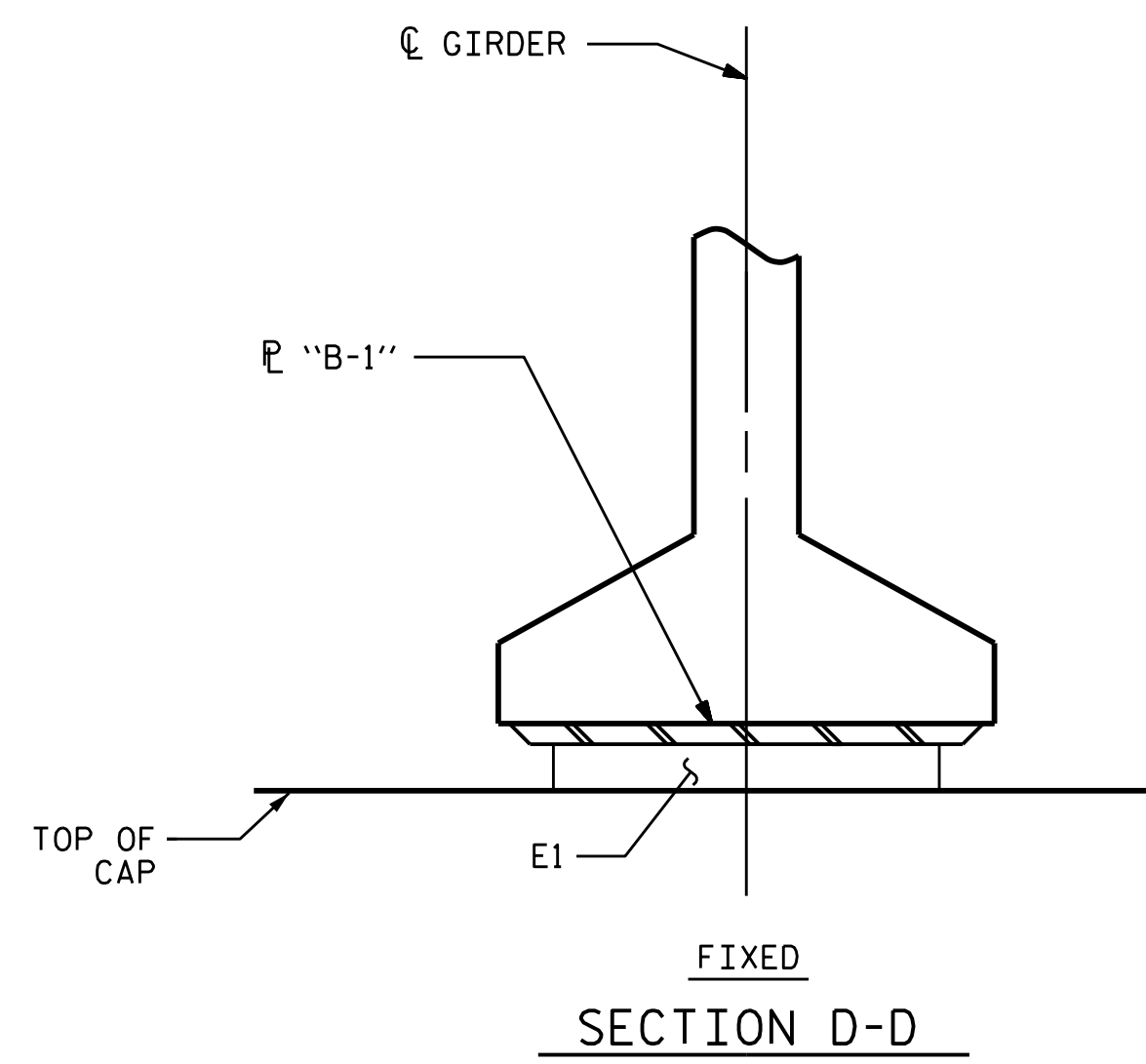

TYPICAL SECTION OF ELASTOMERIC BEARINGS

TYPICAL SECTION OF ELASTOMERIC BEARINGS

TYPICAL PLAN @ INTEGRAL END BENT

TYPICAL PLAN @ BENT

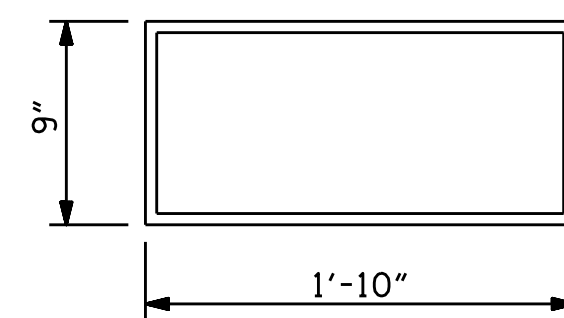

E1 (12 REQ'D)
PLAN VIEW OF ELASTOMERIC BEARING
TYPE IV

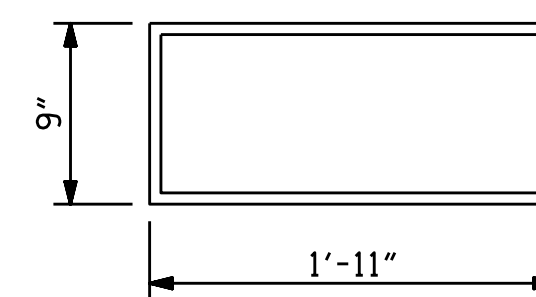

E2 (12 REQ'D)
PLAN VIEW OF ELASTOMERIC BEARING
TYPE V

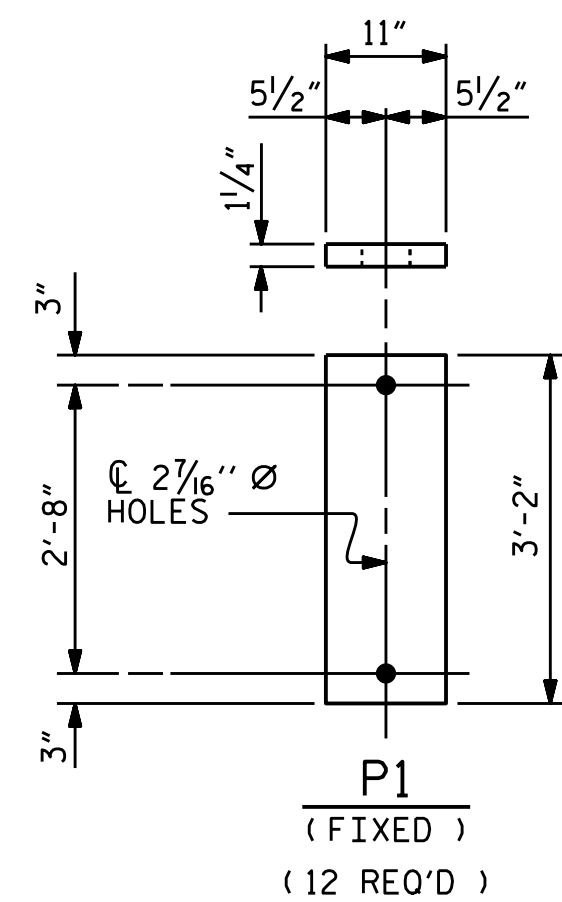

SOLE PLATE DETAILS

MAXIMUM ALLOWABLE SERVICE LOADS	
D.L.+L.L. (NO IMPACT)	
TYPE IV	225 K
TYPE V	365 K

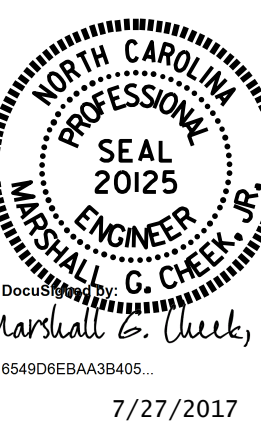

PROJECT NO. U-2579C
FORSYTH COUNTY
 STATION: 29+24.97 -Y1-

STATE OF NORTH CAROLINA
 DEPARTMENT OF TRANSPORTATION
 RALEIGH
 STANDARD
**ELASTOMERIC BEARING
 DETAILS**
 PRESTRESSED CONCRETE GIRDER
 SUPERSTRUCTURE

ASSEMBLED BY : J. P. MCCARTHA DATE : 3/8/16
 CHECKED BY : H.A. LOCKLEAR DATE : 8/26/16
 DRAWN BY : EEM 2/97 REV. 10/1/11 MAA/GM
 CHECKED BY : VAP 2/97 REV. 6/13 AAC/MAA
 REV. 1/15 MAA/TMG

DOCUMENT NOT CONSIDERED
 FINAL UNLESS ALL
 SIGNATURES COMPLETED

REVISIONS						SHEET NO.
NO.	BY:	DATE:	NO.	BY:	DATE:	S1-16
1			3			TOTAL SHEETS
2			4			32

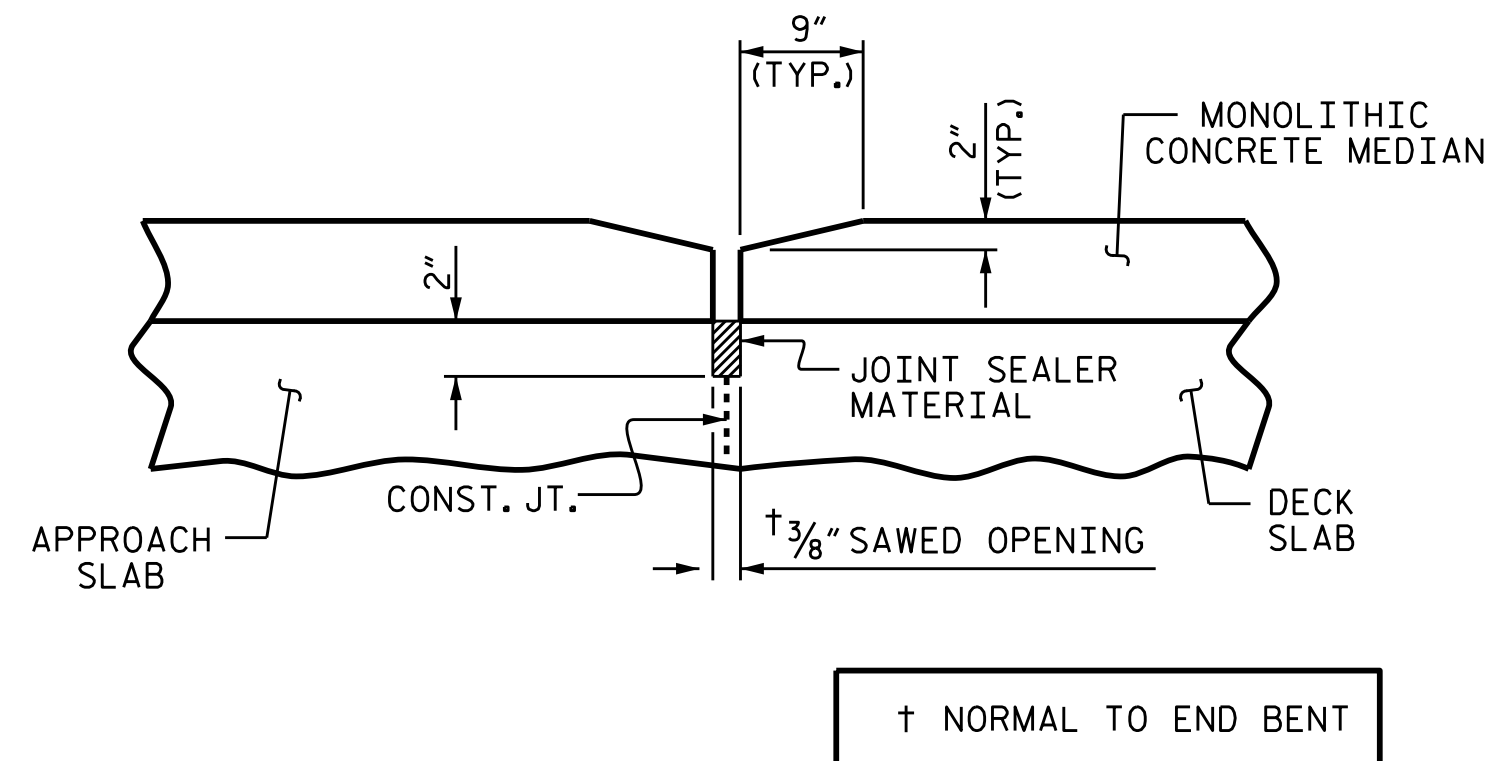

SECTION THROUGH MONOLITHIC CONCRETE MEDIAN AT INTEGRAL END BENT
 END BENT 1 SHOWN, END BENT 2 SIMILAR

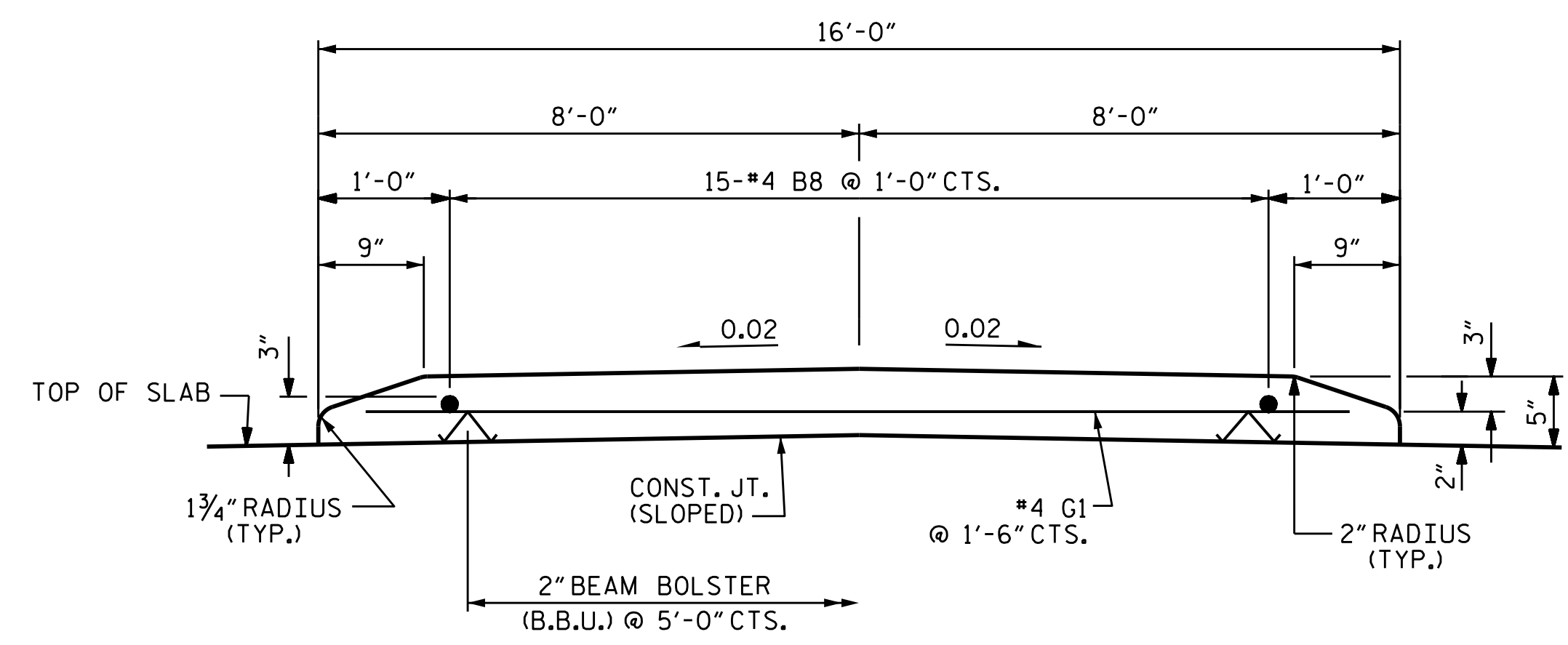

SECTION THROUGH MONOLITHIC CONCRETE MEDIAN

NOTES

GROOVED CONTRACTION JOINTS, 1/2" IN DEPTH, SHALL BE TOOLED IN ALL EXPOSED FACES OF THE MONOLITHIC CONCRETE MEDIAN IN ACCORDANCE WITH ARTICLE 825-10(B) OF THE STANDARD SPECIFICATIONS. THE CONTRACTION JOINTS SHALL BE LOCATED AT A SPACING OF 8 FT. TO 10 FT. BETWEEN EXPANSION JOINTS. NO CONTRACTION JOINT WILL BE REQUIRED FOR SEGMENTS LESS THAN 10 FT. IN LENGTH.

ALL REINFORCING STEEL IN MONOLITHIC CONCRETE MEDIAN SHALL BE EPOXY COATED.

FOR MONOLITHIC CONCRETE MEDIAN ON APPROACH SLAB, SEE "BRIDGE APPROACH SLAB" SHEETS.

NO SEPARATE MEASUREMENT OR PAYMENT WILL BE MADE FOR MATERIALS OR LABOR REQUIRED TO CONSTRUCT THE CONCRETE MEDIAN. THE ENTIRE COST OF THIS WORK SHALL BE INCLUDED IN THE UNIT PRICE BID FOR REINFORCED CONCRETE DECK SLAB.

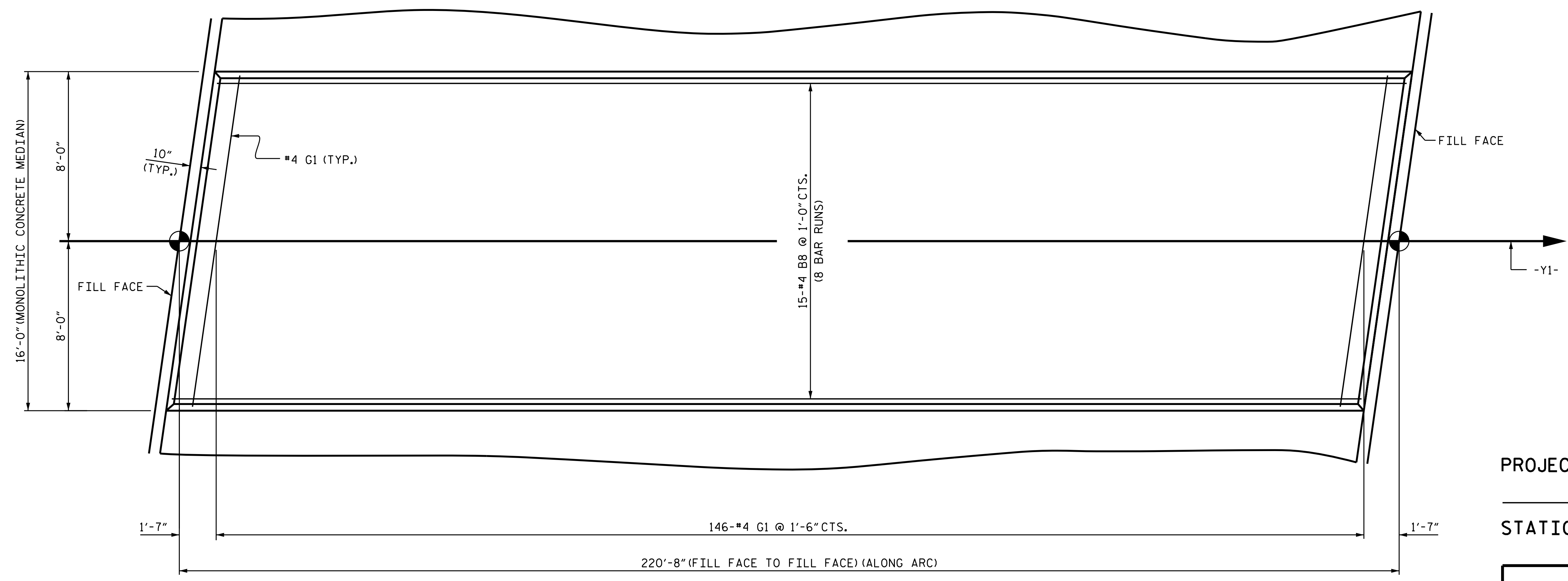

PLAN OF MONOLITHIC CONCRETE MEDIAN

PROJECT NO. U-2579C
 FORSYTH COUNTY
 STATION: 29+24.97 -Y1-

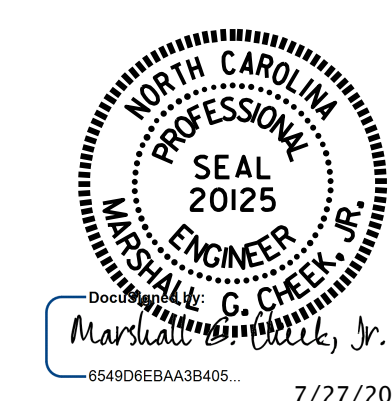

STATE OF NORTH CAROLINA
 DEPARTMENT OF TRANSPORTATION
 RALEIGH
 SUPERSTRUCTURE
 MONOLITHIC
 CONCRETE MEDIAN
 DETAILS

DRAWN BY : J.P. MCCARTHA DATE : 5/4/16
 CHECKED BY : H.A. LOCKLEAR DATE : 8/25/16
 DESIGN ENGINEER OF RECORD: H.A. LOCKLEAR DATE : 6/2017

DOCUMENT NOT CONSIDERED
 FINAL UNLESS ALL
 SIGNATURES COMPLETED

REVISIONS						SHEET NO.	
NO.	BY:	DATE:	NO.	BY:	DATE:	S1-17	
1			3			TOTAL SHEETS	
2			4			32	

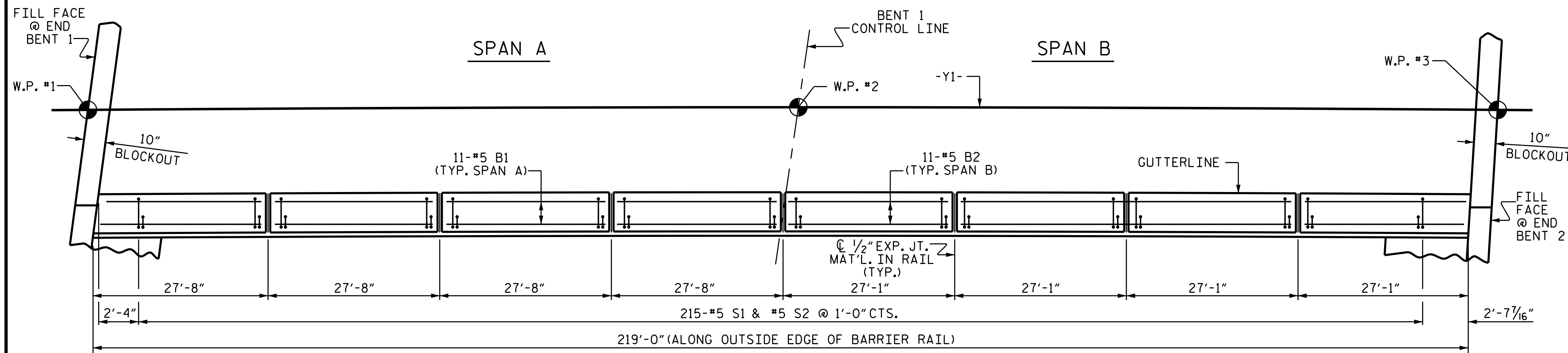

PLAN OF CONCRETE BARRIER RAIL

(RIGHT SIDE BARRIER RAIL SHOWN, LEFT SIDE SIMILAR)

NOTES

THE BARRIER RAIL IN THE CONTINUOUS UNIT SHALL NOT BE CAST UNTIL ALL SLAB CONCRETE IN THAT SPAN HAS BEEN CAST AND HAS REACHED A MINIMUM COMPRESSIVE STRENGTH OF 3,000 PSI.

ALL REINFORCING STEEL IN BARRIER RAILS SHALL BE EPOXY COATED.

GROOVED CONTRACTION JOINTS, 1/2" IN DEPTH, SHALL BE TOOLED IN ALL EXPOSED FACES OF THE BARRIER RAIL AND IN ACCORDANCE WITH ARTICLE 825-10(B) OF THE STANDARD SPECIFICATIONS. THE CONTRACTION JOINT SHALL BE LOCATED AT EACH THIRD POINT BETWEEN BARRIER RAIL EXPANSION JOINTS. ONLY ONE CONTRACTION JOINT IS REQUIRED AT MIDPOINT OF BARRIER RAIL SEGMENTS LESS THAN 20 FEET IN LENGTH AND NO CONTRACTION JOINTS ARE REQUIRED FOR THOSE SEGMENTS LESS THAN 10 FEET IN LENGTH.

THE #5 S1 AND #5 S2 BARS MAY BE SHIFTED SLIGHTLY IN ORDER TO MAINTAIN 2" MINIMUM CLEARANCE TO THE 1/2" EXPANSION JOINT MATERIAL IN THE BARRIER RAIL.

BAR TYPES

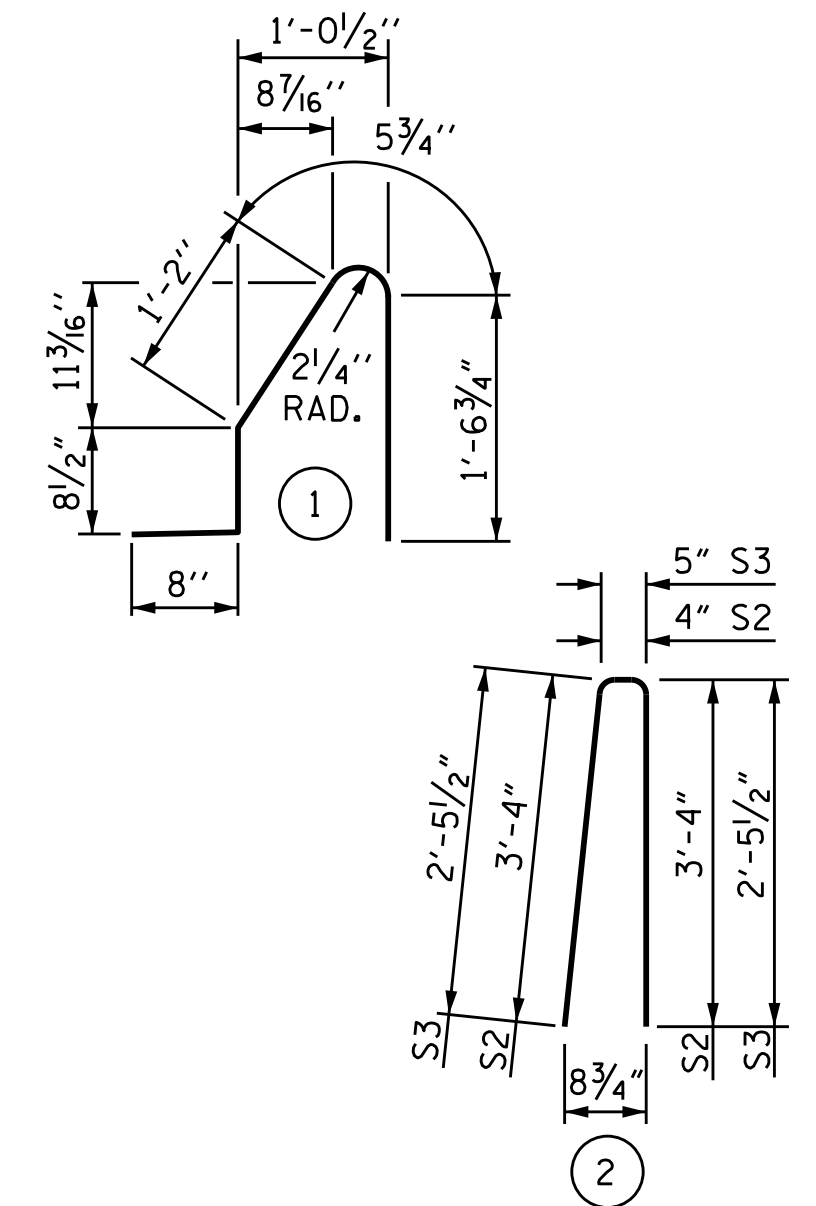

ALL BAR DIMENSIONS ARE OUT TO OUT.

BILL OF MATERIAL

FOR CONCRETE BARRIER RAIL ONLY

BAR	NO.	SIZE	TYPE	LENGTH	WEIGHT
* B1	88	#5	STR	27'-3"	2501
* B2	88	#5	STR	26'-8"	2448
* S1	438	#5	1	4'-7"	2094
* S2	430	#5	2	7'-0"	3139
* S3	8	#5	2	5'-4"	45
* EPOXY COATED REINFORCING STEEL					LBS. 10,227
CLASS AA CONCRETE					C.Y. 59.6
CONCRETE BARRIER RAIL					LN. FT. 438.00

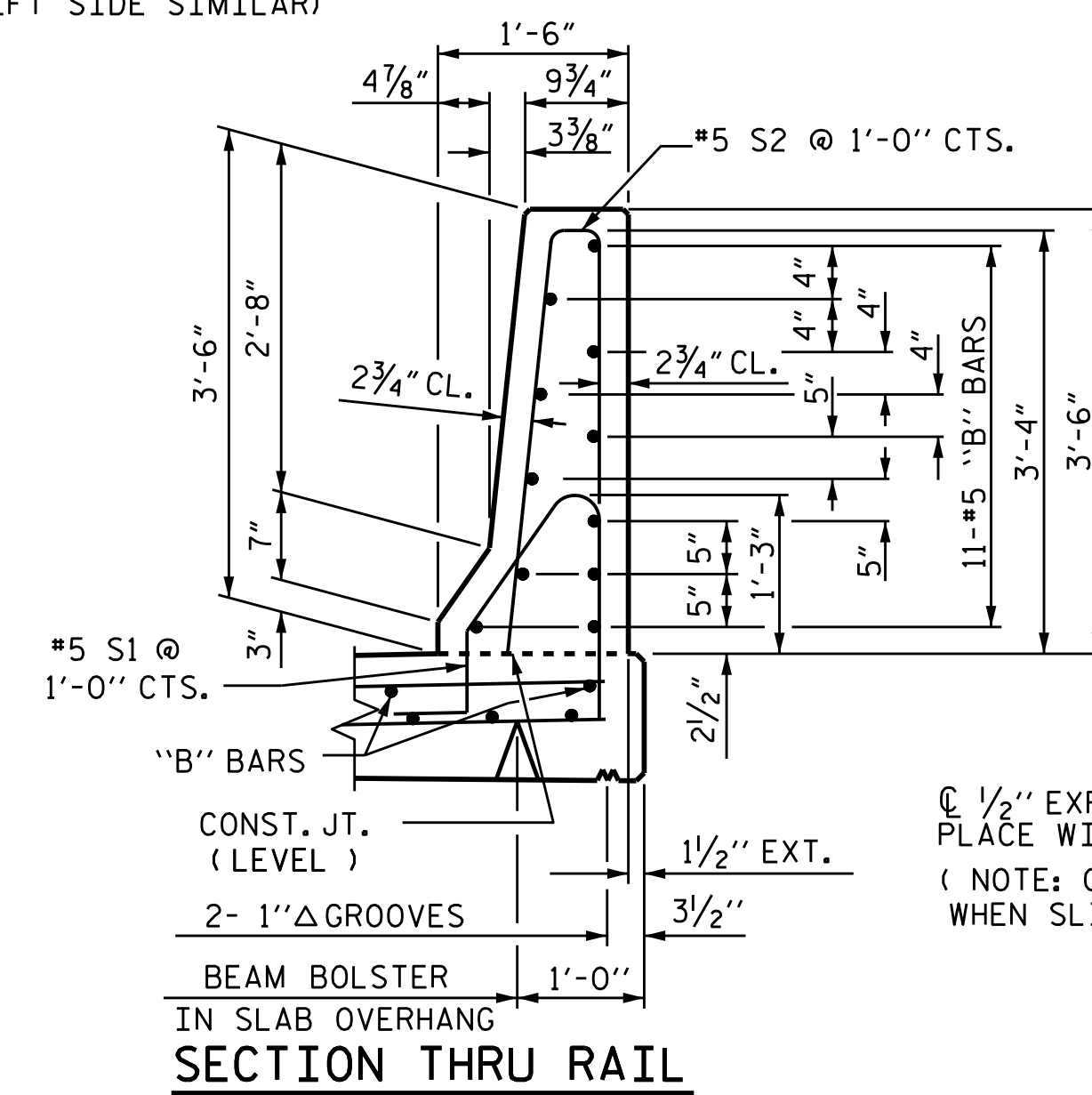

1/2" EXP. JT. MAT'L HELD IN PLACE WITH GALVANIZED NAILS. (NOTE: OMIT EXP. JT. MAT'L WHEN SLIP FORM IS USED.)

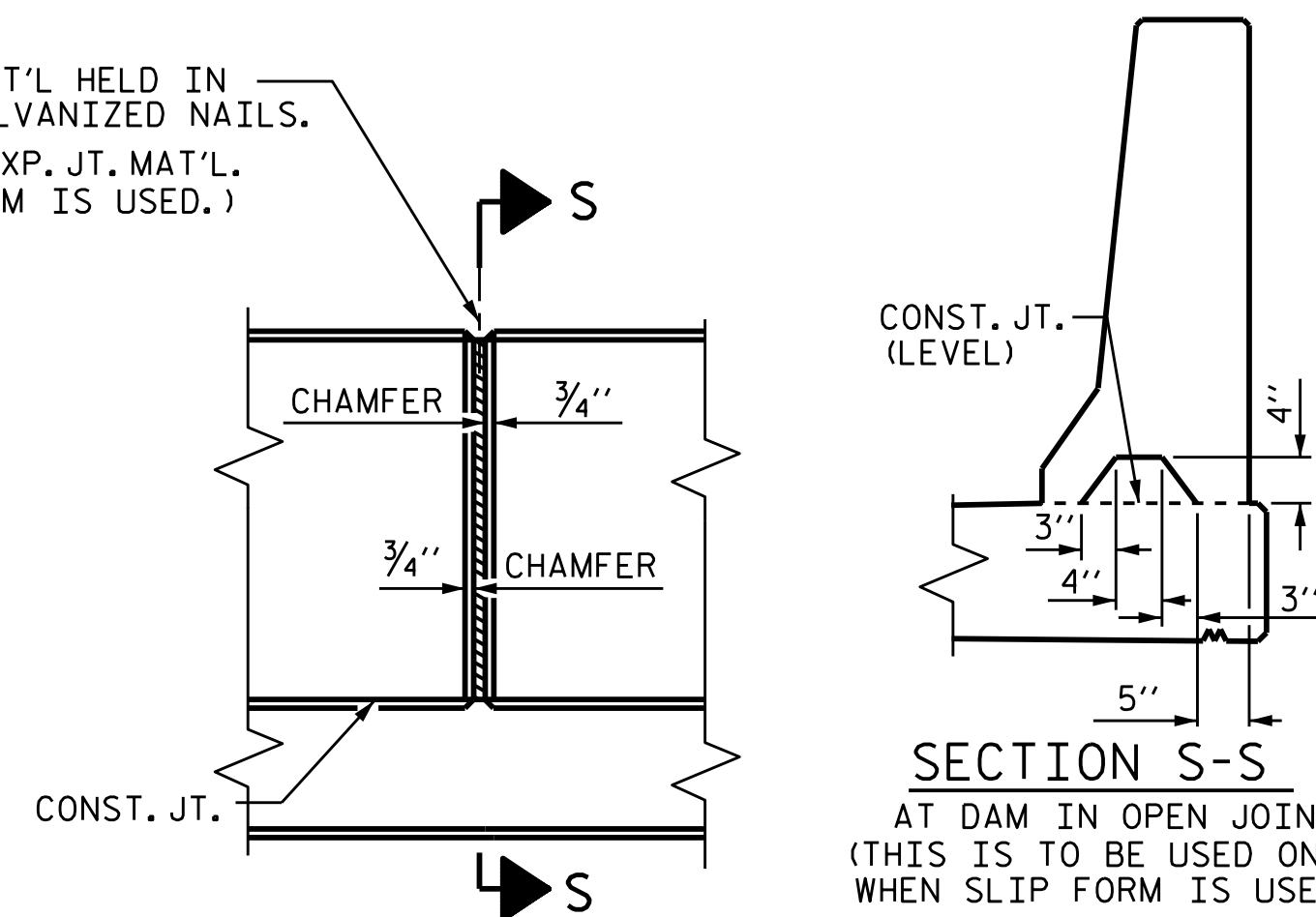

**ELEVATION AT EXPANSION JOINTS
BARRIER RAIL DETAILS**

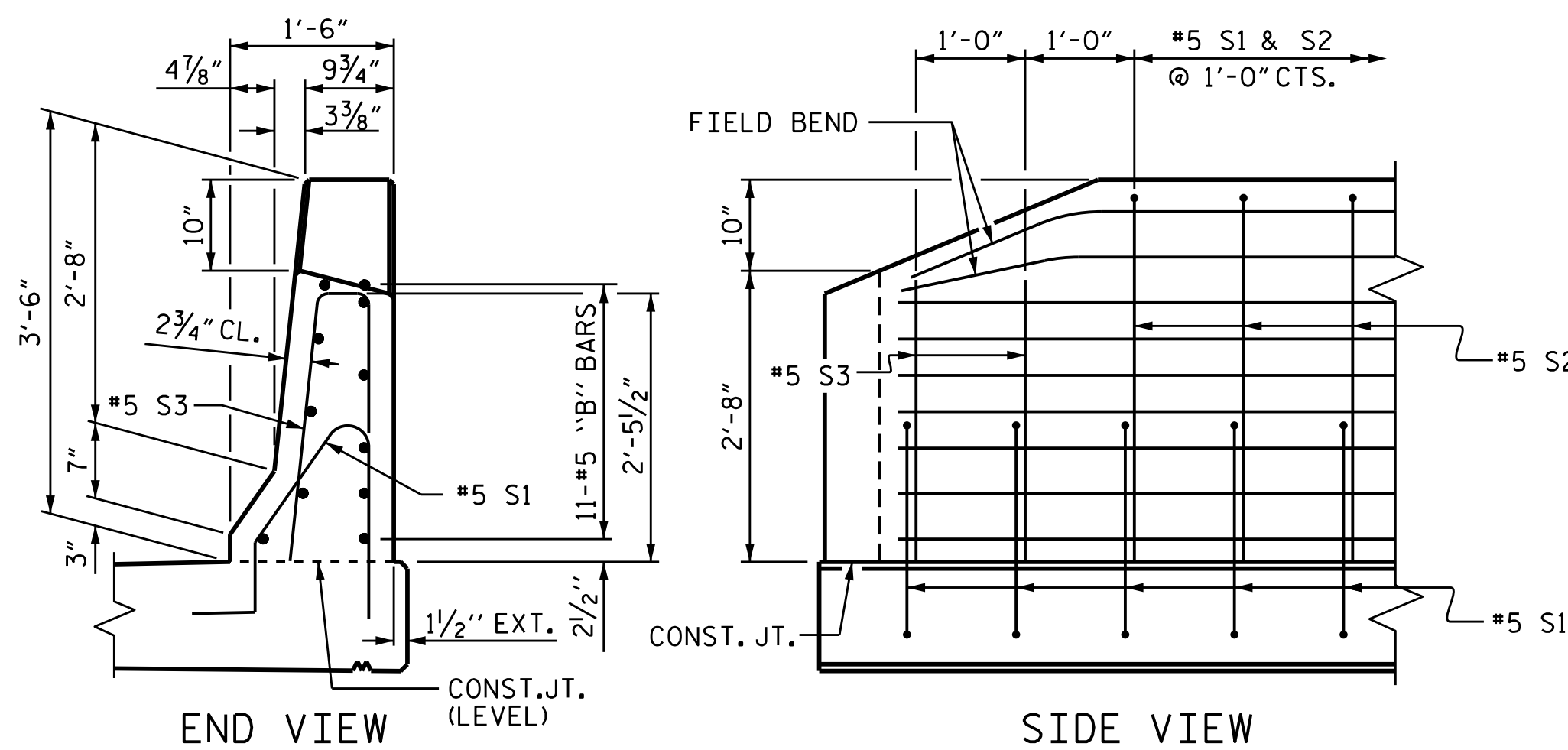
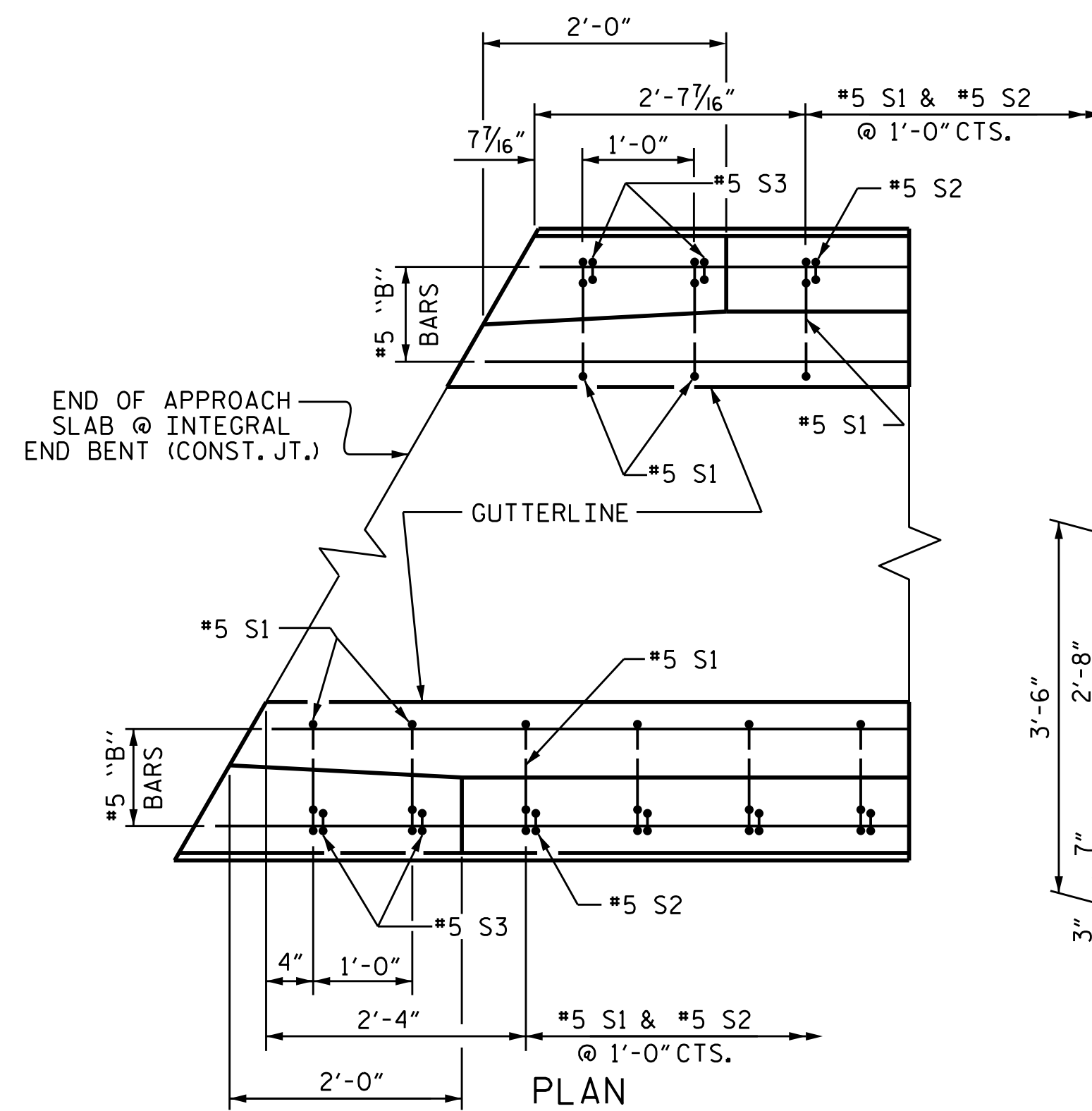

END OF RAIL DETAILS

DRAWN BY : J.P. MCCARTHA DATE : 4/26/16
CHECKED BY : H.A. LOCKLEAR DATE : 8/26/16

DOCUMENT NOT CONSIDERED FINAL UNLESS ALL SIGNATURES COMPLETED

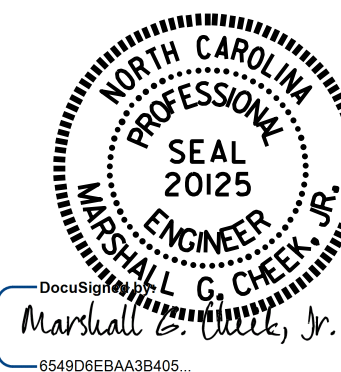

7/27/2017

PROJECT NO. U-2579C
FORSYTH COUNTY
STATION: 29+24.97 -Y1-

STATE OF NORTH CAROLINA
DEPARTMENT OF TRANSPORTATION
RALEIGH

3'-6" CONCRETE BARRIER RAIL

REVISIONS

NO.	BY:	DATE:	NO.	BY:	DATE:
1			3		
2			4		

SHEET NO.

S1-18

TOTAL SHEETS

32

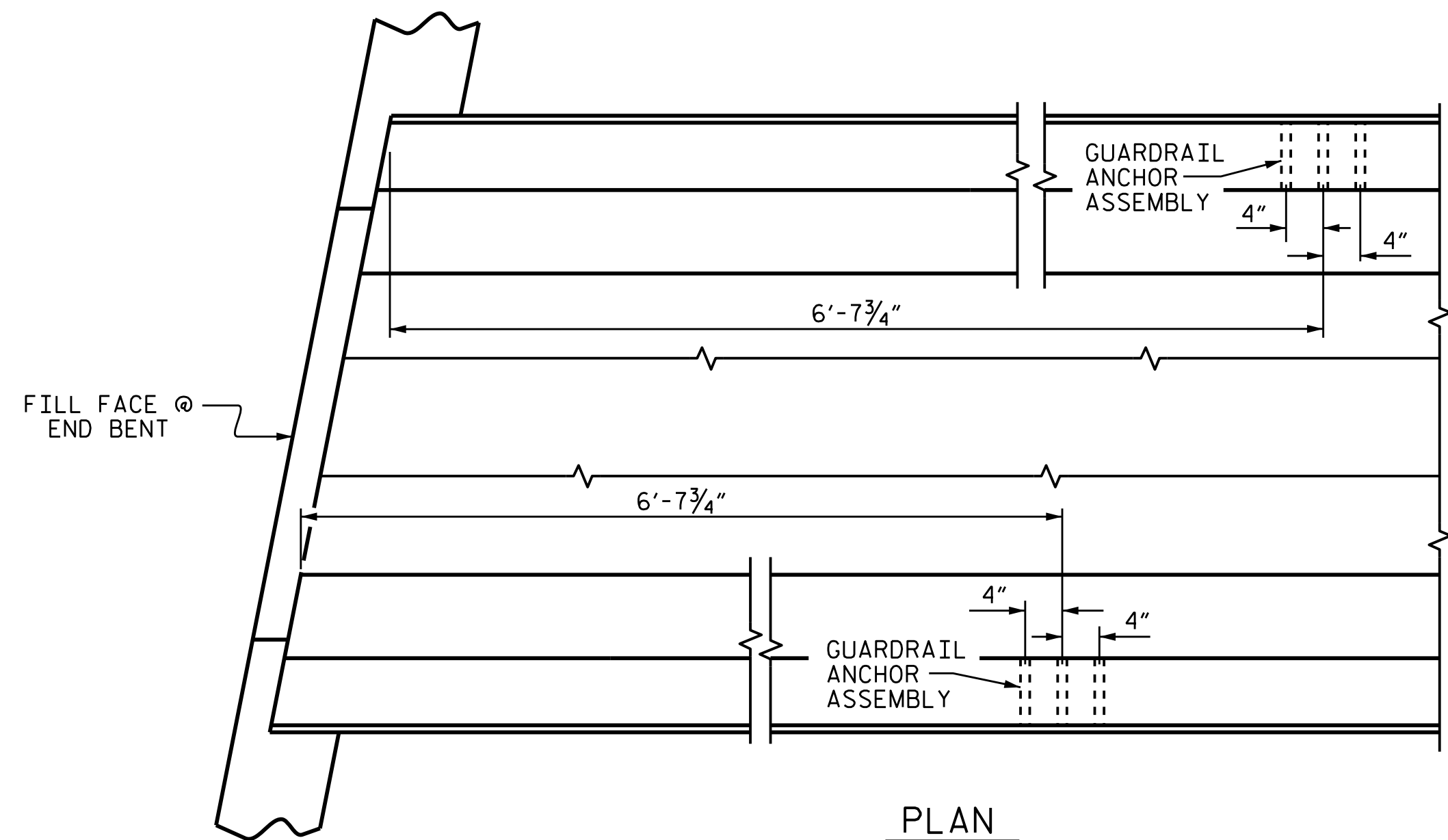
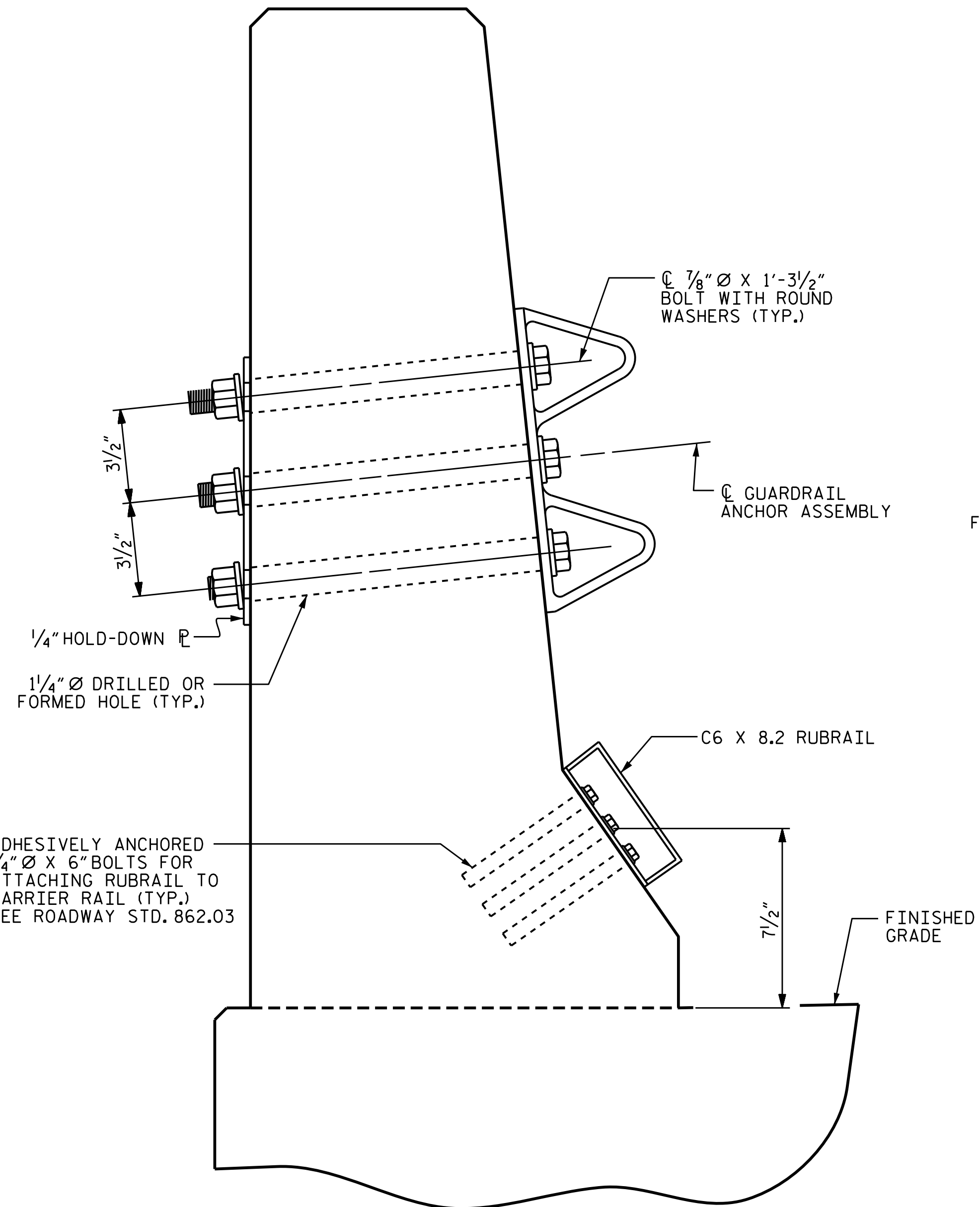
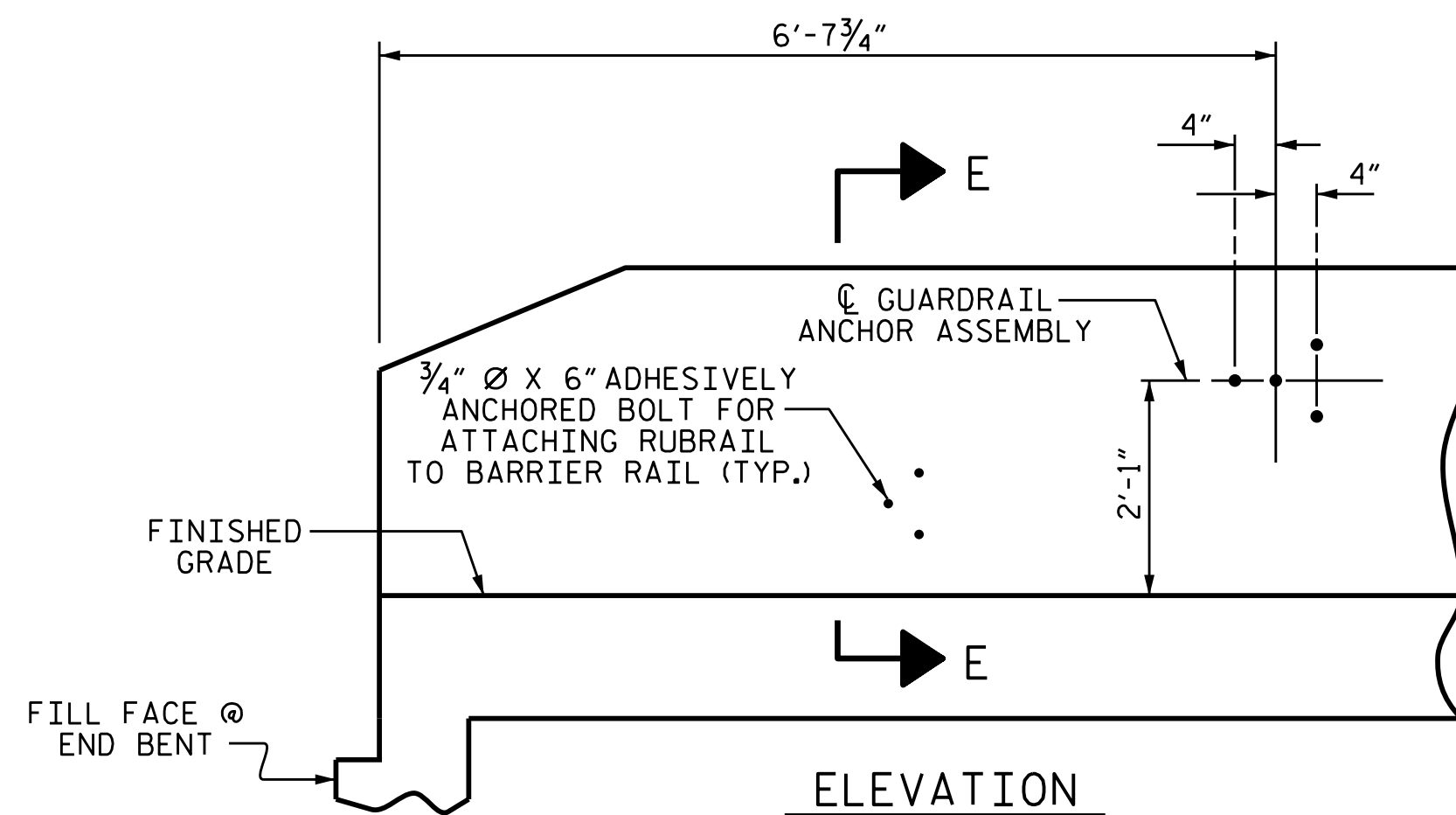
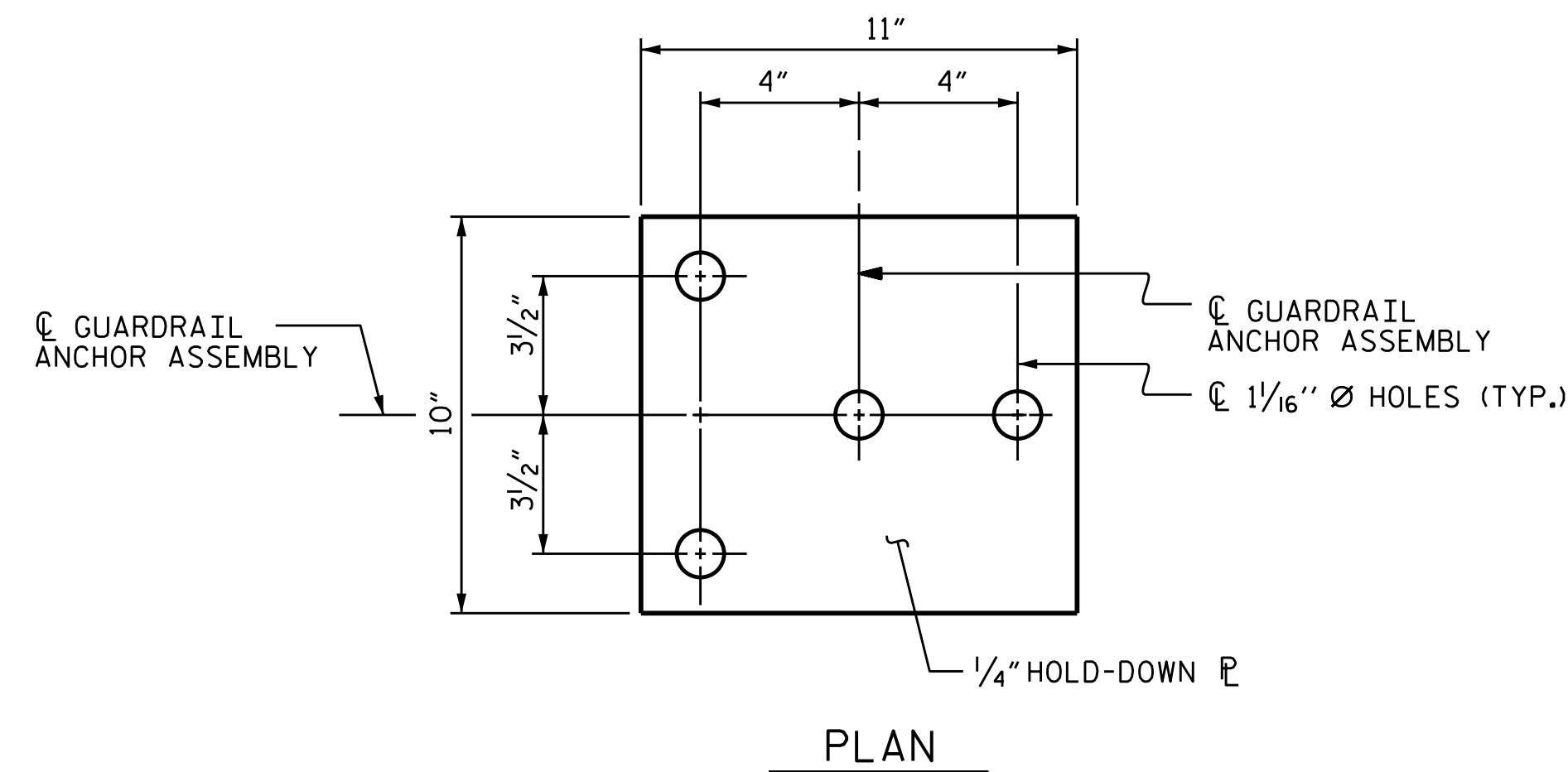

LOCATION OF ANCHORS FOR GUARDRAIL

END BENT 1 SHOWN, END BENT 2 SIMILAR.

NOTES

THE GUARDRAIL ANCHOR ASSEMBLY SHALL CONSIST OF A 1/4" HOLD-DOWN PLATE AND 4 - 7/8" Ø BOLTS WITH NUTS AND WASHERS, RUBRAIL, AND ADHESIVELY ANCHORED BOLTS.

THE HOLD-DOWN PLATE SHALL CONFORM TO AASHTO M270 GRADE 36. AFTER FABRICATION, THE HOLD-DOWN PLATE SHALL BE HOT-DIP GALVANIZED IN ACCORDANCE WITH AASHTO M111.

BOLTS SHALL CONFORM TO THE REQUIREMENTS OF ASTM A307 AND NUTS SHALL CONFORM TO THE REQUIREMENTS OF AASHTO M291. BOLTS, NUTS AND WASHERS SHALL BE GALVANIZED. (AT THE CONTRACTOR'S OPTION, STAINLESS STEEL BOLTS, NUTS AND WASHERS MAY BE USED AS AN ALTERNATE FOR THE 7/8" Ø GALVANIZED BOLTS, NUTS AND WASHERS. THEY SHALL CONFORM TO OR EXCEED THE MECHANICAL REQUIREMENTS OF ASTM A307. THE USE OF THIS ALTERNATE SHALL BE APPROVED BY THE ENGINEER.)

THE GUARDRAIL ANCHOR ASSEMBLY IS REQUIRED AT ALL POINTS WHERE APPROACH GUARDRAIL IS TO BE ATTACHED TO THE END OF BARRIER RAIL. FOR POINTS OF ATTACHMENT, SEE SKETCH.

AFTER INSTALLATION, THE EXPOSED THREAD OF THE BOLT SHALL BE BURRED WITH A SHARP POINTED TOOL.

THE COST OF THE GUARDRAIL ANCHOR ASSEMBLY SHALL BE INCLUDED IN THE UNIT CONTRACT PRICE BID FOR CONCRETE BARRIER RAIL.

THE 1 1/4" Ø HOLES SHALL BE FORMED OR DRILLED WITH A CORE BIT. IMPACT TOOLS WILL NOT BE PERMITTED. ANY CONCRETE DAMAGED BY THIS WORK SHALL BE REPAIRED TO THE SATISFACTION OF THE ENGINEER.

THE C6 X 8.2 RUBRAIL IS TO BE ADHESIVELY ANCHORED TO THE RAIL USING THREE 3/4" Ø X 6" BOLTS WITH WASHERS. LEVEL ONE FIELD TESTING IS REQUIRED, AND THE YIELD LOAD OF THE 3/4" Ø BOLT IS 12 KIPS. FOR ADHESIVELY ANCHORED ANCHOR BOLTS OR DOWELS, SEE STANDARD SPECIFICATIONS. SEE ROADWAY STANDARD 862.03 FOR DETAILS AND LOCATION OF THE RUBRAIL.

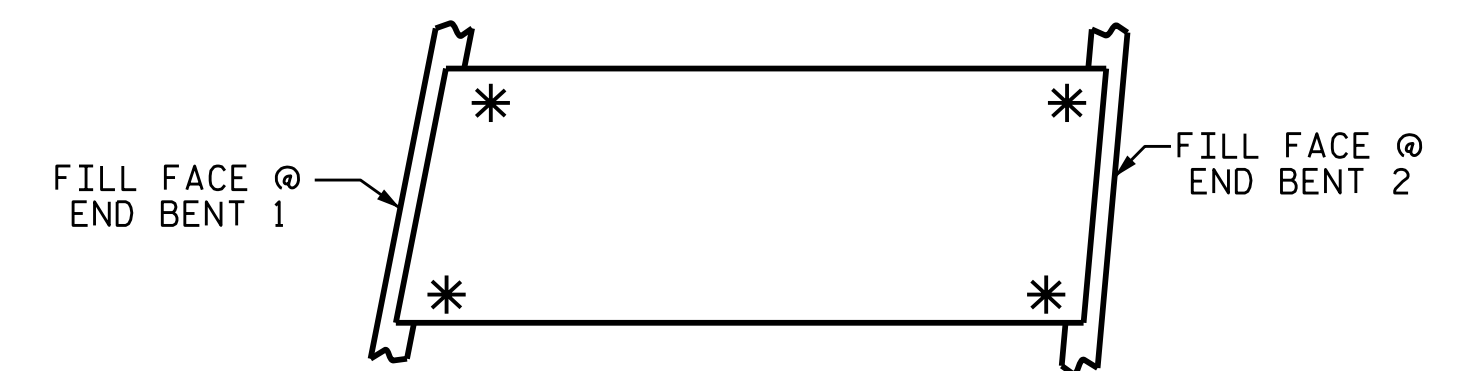

SKETCH SHOWING POINTS OF ATTACHMENTS

* DENOTES GUARDRAIL ANCHOR ASSEMBLY

PROJECT NO. U-2579C
 FORSYTH COUNTY
 STATION: 29+24.97 -Y1-

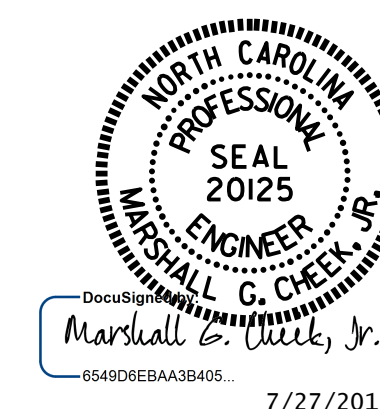

STATE OF NORTH CAROLINA
 DEPARTMENT OF TRANSPORTATION
 RALEIGH
 STANDARD
 GUARDRAIL ANCHORAGE
 FOR BARRIER RAIL

ASSEMBLED BY : J. P. MCCARTHA	DATE : 3/8/16
CHECKED BY : H.A. LOCKLEAR	DATE : 8/25/16
DRAWN BY : TLA 5/06	REV. 10/1/11 MAA/GM
CHECKED BY : GM 5/06	REV. 7/12 MAA/GM
	REV. 6/13 MAA/GM

26-JUL-2017 15:04
 R:\Structures\FINAL PLANS\401_037_U2579C_SMU_GR_019_330700.dgn
 mcheek

DOCUMENT NOT CONSIDERED
 FINAL UNLESS ALL
 SIGNATURES COMPLETED

REVISIONS						SHEET NO.
NO.	BY:	DATE:	NO.	BY:	DATE:	S1-19
1			3			TOTAL SHEETS
2			4			32

STR. #1 STD. NO. GRA2

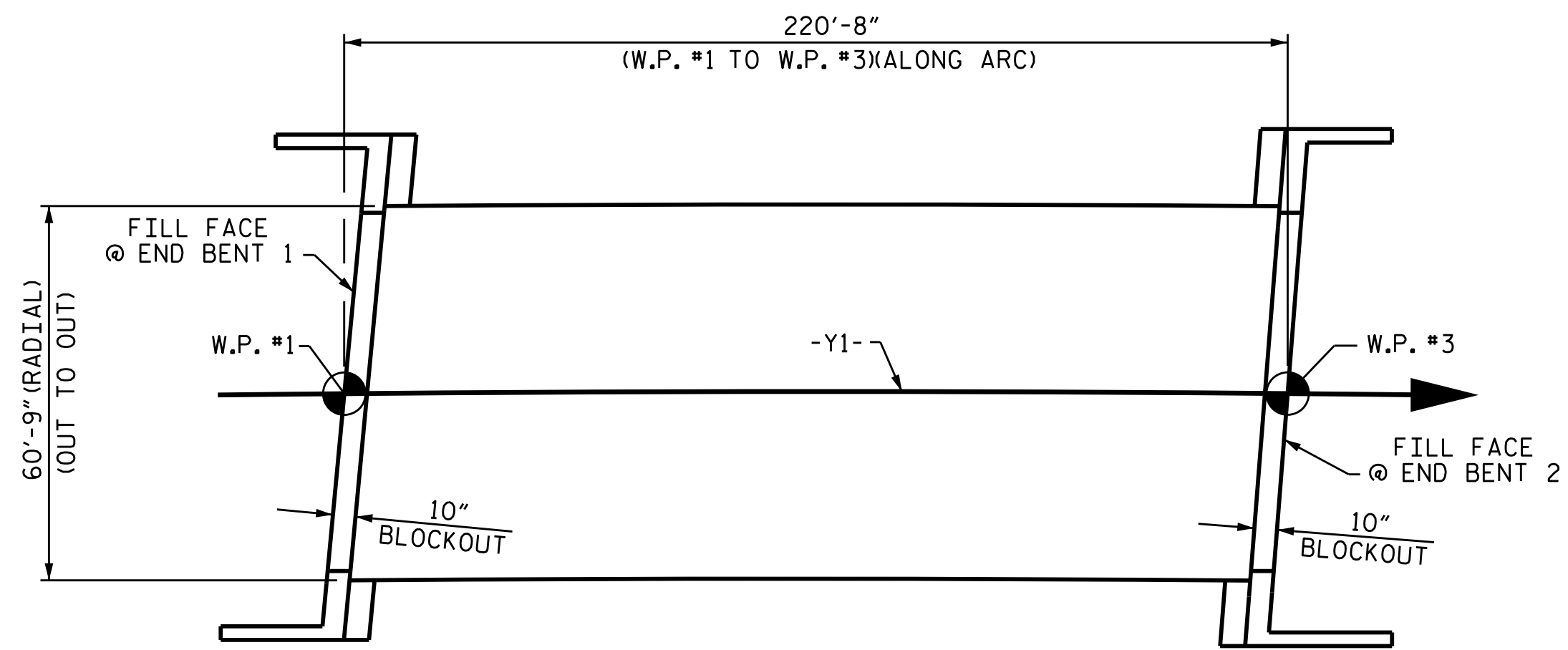

LAYOUT FOR COMPUTING AREA
REINFORCED CONCRETE DECK SLAB
(SQ. FT. = 13,406)

BAR TYPES

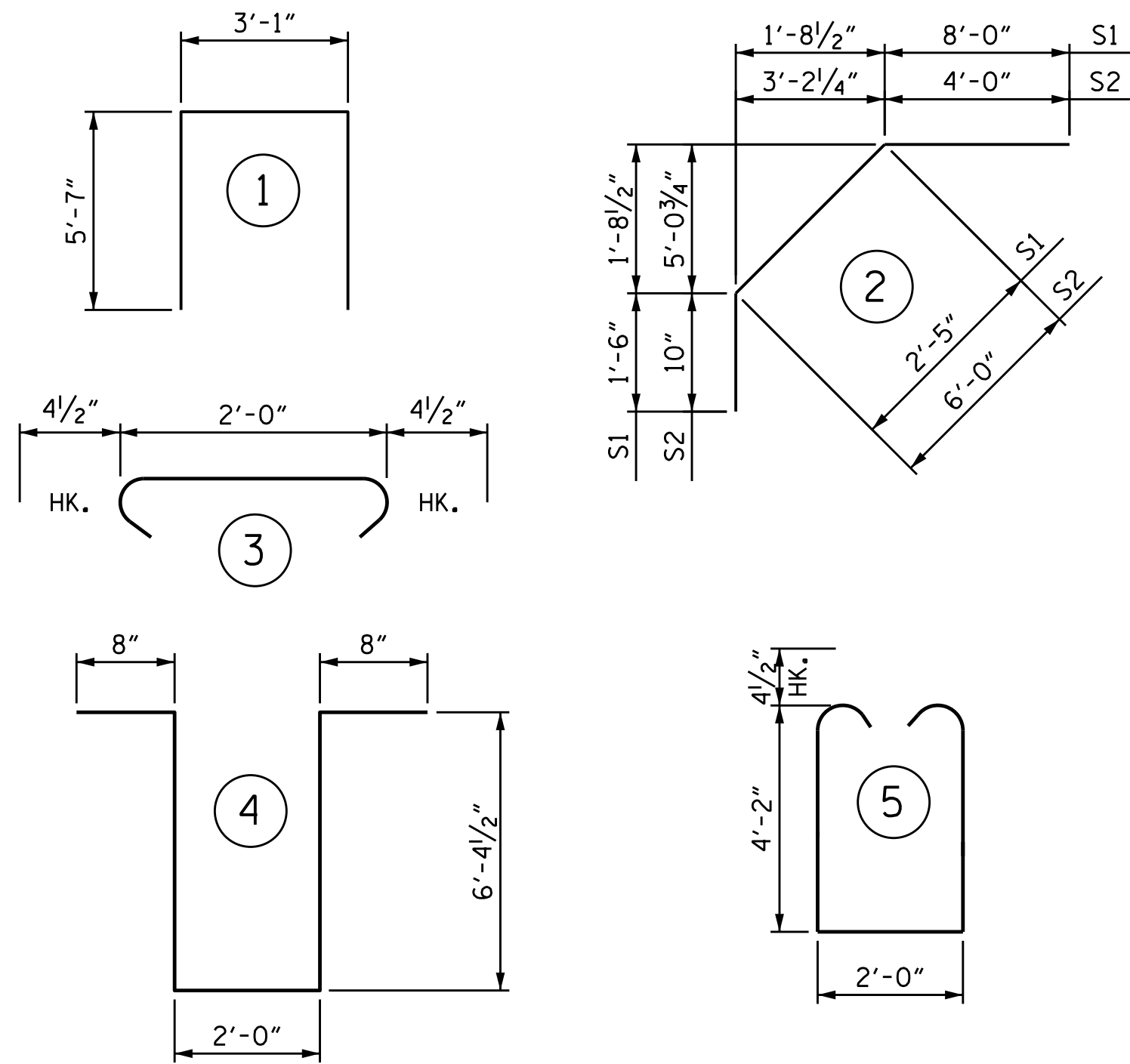

ALL BAR DIMENSIONS ARE OUT TO OUT.

REINFORCING BAR SCHEDULE						REINFORCING BAR SCHEDULE					
BAR NO.	NO.	SIZE	TYPE	LENGTH	WEIGHT	BAR NO.	NO.	SIZE	TYPE	LENGTH	WEIGHT
*A1	744	#5	STR	31'-6"	24444	K4	100	#4	STR	9'-5"	629
A2	744	#5	STR	31'-4"	24314	K5	4	#4	STR	2'-5"	6
						K6	4	#4	STR	3'-1"	8
*A101	1	#5	STR	49'-0"	51	K7	20	#4	STR	3'-11"	52
*A102	1	#5	STR	28'-6"	30	K8	10	#4	STR	6'-8"	45
*A103	1	#5	STR	8'-1"	8	K9	14	#4	STR	26'-9"	250
*A104	1	#5	STR	49'-2"	51						
*A105	1	#5	STR	28'-9"	30	*S1	88	#4	2	11'-11"	701
*A106	1	#5	STR	8'-3"	9	*S2	88	#4	2	10'-10"	637
						S3	88	#4	1	14'-3"	838
A201	1	#5	STR	49'-0"	51	S4	280	#4	3	2'-9"	514
A202	1	#5	STR	28'-6"	30						
A203	1	#5	STR	8'-1"	8	U1	30	#4	4	16'-1"	322
A204	1	#5	STR	49'-2"	51	U2	20	#4	5	11'-1"	148
A205	1	#5	STR	28'-9"	30						
A206	1	#5	STR	8'-3"	9						
*B1	8	#5	STR	56'-7"	472	REINFORCING STEEL		LBS.		40,028	
*B2	322	#5	STR	22'-4"	7501	*EPOXY COATED REINFORCING STEEL		LBS.		50,212	
*B3	82	#4	STR	27'-11"	1529						
*B4	162	#5	STR	39'-5"	6660						
*B5	80	#5	STR	33'-2"	2767						
B6	204	#5	STR	56'-4"	11986						
*B7	82	#4	STR	27'-0"	1479						
*B8	120	#4	STR	29'-1"	2331						
*G1	146	#4	STR	15'-6"	1512						
K1	42	#4	STR	21'-4"	599						
K2	20	#4	STR	6'-5"	86						
K3	10	#4	STR	7'-10"	52						

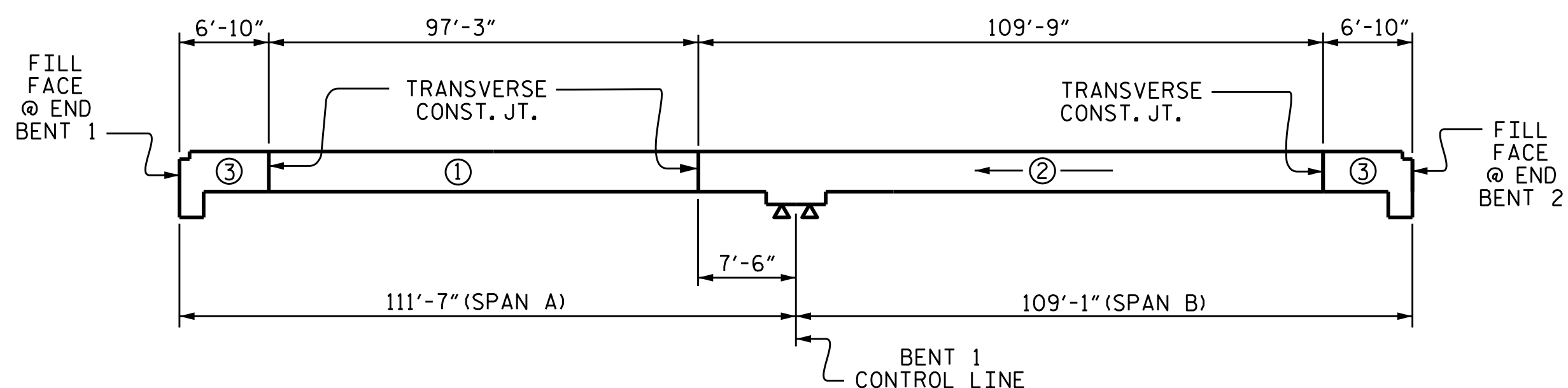

POUR SEQUENCE

—SUPERSTRUCTURE BILL OF MATERIAL—			
	CLASS AA CONCRETE (CU. YDS.)	REINFORCING STEEL (LBS.)	EPOXY COATED REINFORCING STEEL (LBS.)
POUR #1	194.6	40,028	46,369
POUR #2	245.3		
POUR #3	113.0		
CONCRETE MEDIAN	52.5		3,843
TOTALS**	605.4	40,028	50,212

**QUANTITIES FOR CONCRETE BARRIER RAILS ARE NOT INCLUDED.

GROOVING BRIDGE FLOORS	
APPROACH SLABS	1,861 SQ. FT.
BRIDGE DECK	8,419 SQ. FT.
TOTAL	10,280 SQ. FT.

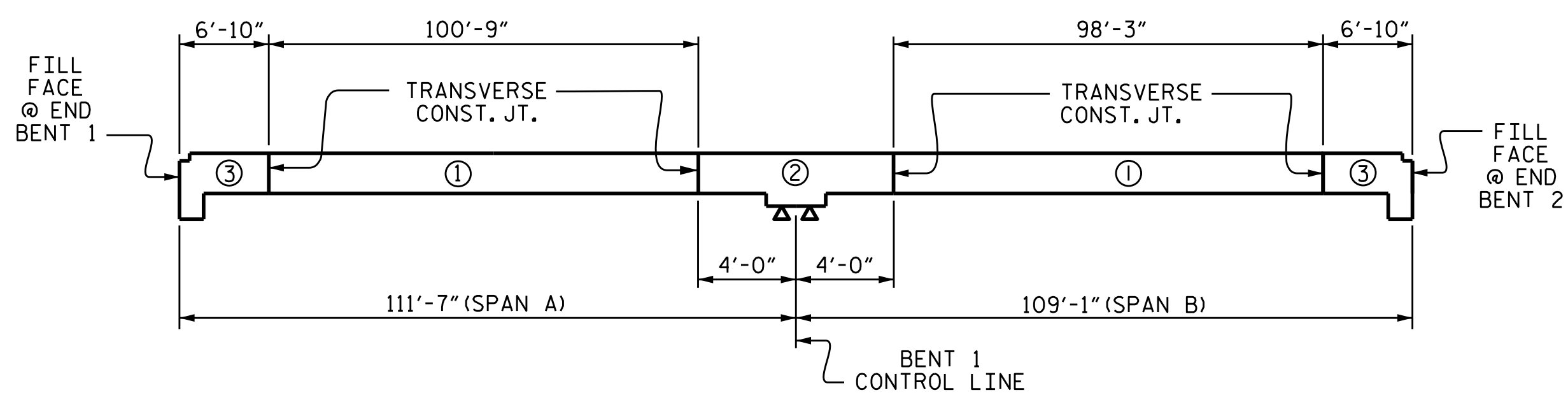

OPTIONAL POUR SEQUENCE

BAR SIZE	SUPERSTRUCTURE REINFORCING STEEL LENGTHS ARE BASED ON THE FOLLOWING MINIMUM SPLICE LENGTHS				PARAPET AND BARRIER RAIL
	SUPERSTRUCTURE EXCEPT APPROACH SLABS, PARAPET, AND BARRIER RAIL		APPROACH SLABS		
	EPOXY COATED	UNCOATED	EPOXY COATED	UNCOATED	
#4	2'-0"	1'-9"	2'-0"	1'-9"	2'-9"
#5	2'-6"	2'-2"	2'-6"	2'-2"	3'-5"
#6	3'-0"	2'-7"	3'-10"	2'-7"	4'-4"
#7	5'-3"	3'-6"			
#8	6'-10"	4'-7"			

PROJECT NO. U-2579C
FORSYTH COUNTY
 STATION: 29+24.97 -Y1-

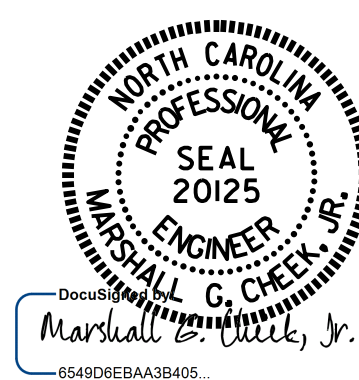

STATE OF NORTH CAROLINA
 DEPARTMENT OF TRANSPORTATION
 RALEIGH
 SUPERSTRUCTURE
 BILL OF MATERIAL

DRAWN BY : J.P. MCCARTHA DATE: 3/29/16
 CHECKED BY : H.A. LOCKLEAR DATE: 8/25/16

DOCUMENT NOT CONSIDERED FINAL UNLESS ALL SIGNATURES COMPLETED

REVISIONS						SHEET NO.
NO.	BY:	DATE:	NO.	BY:	DATE:	S1-20
1			3			TOTAL SHEETS
2			4			32

NOTES

THE TOP SURFACE OF THE END BENT CAP, EXCEPT THE BEARING AREA, SHALL BE RAKED TO A DEPTH OF 1/4".

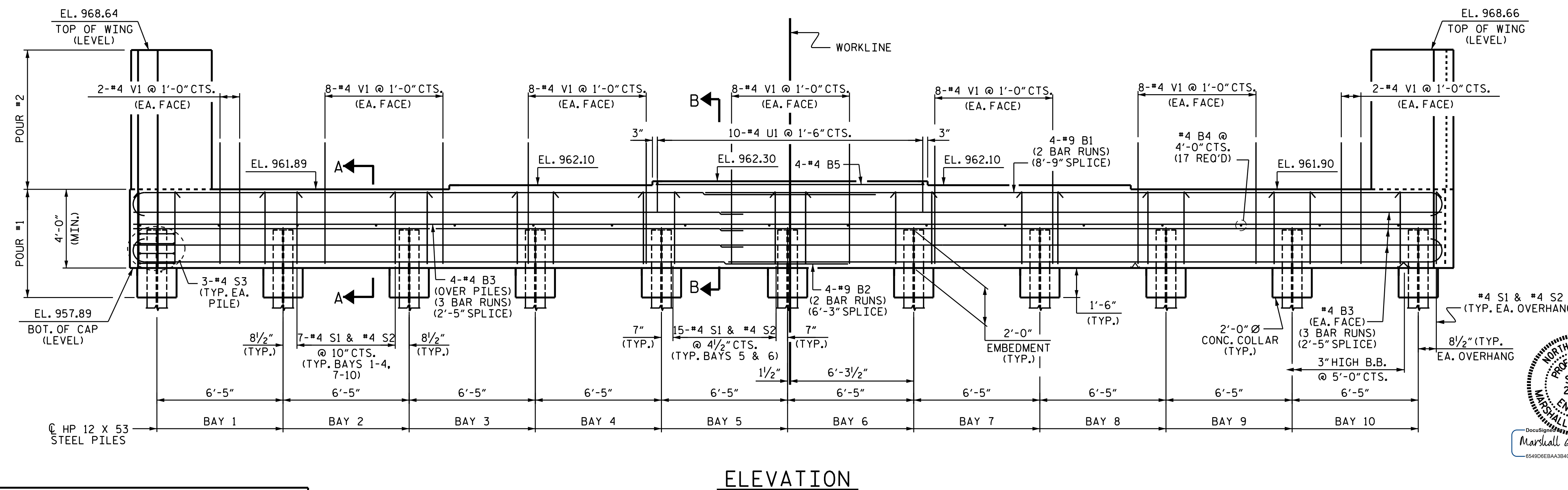
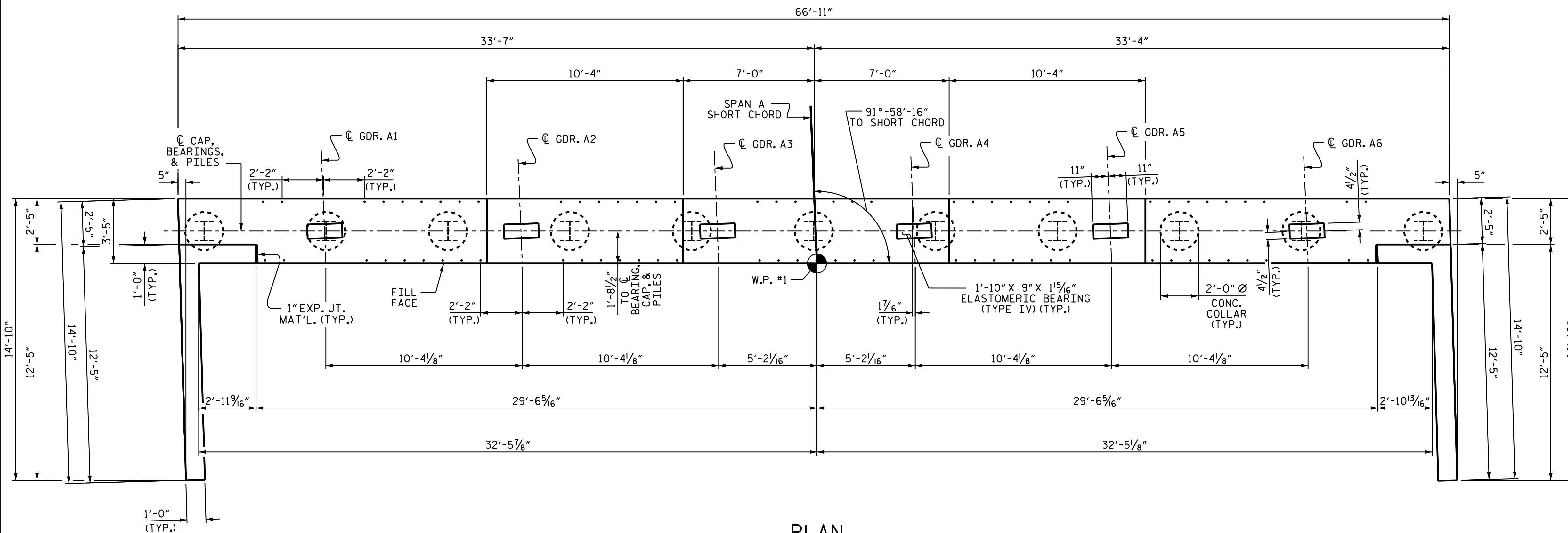

PROJECT NO. U-2579C
FORSYTH COUNTY
 STATION: 29+24.97 -Y1-
 SHEET 1 OF 3

STATE OF NORTH CAROLINA
 DEPARTMENT OF TRANSPORTATION
 RALEIGH

**SUBSTRUCTURE
 INTEGRAL
 END BENT 1**

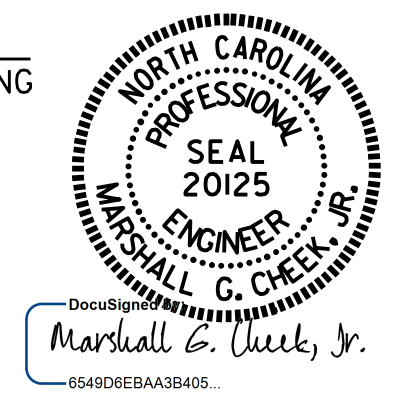

DRAWN BY : N.D. AIUTO DATE : 4/4/16
 CHECKED BY : K.D. LAYNE DATE : 4/14/16
 DESIGN ENGINEER OF RECORD : H.A. LOCKLEAR DATE : 6/2017

DOCUMENT NOT CONSIDERED
 FINAL UNLESS ALL
 SIGNATURES COMPLETED

REVISIONS						SHEET NO.	
NO.	BY:	DATE:	NO.	BY:	DATE:	S1-21	
1			3			TOTAL SHEETS	
2			4			32	

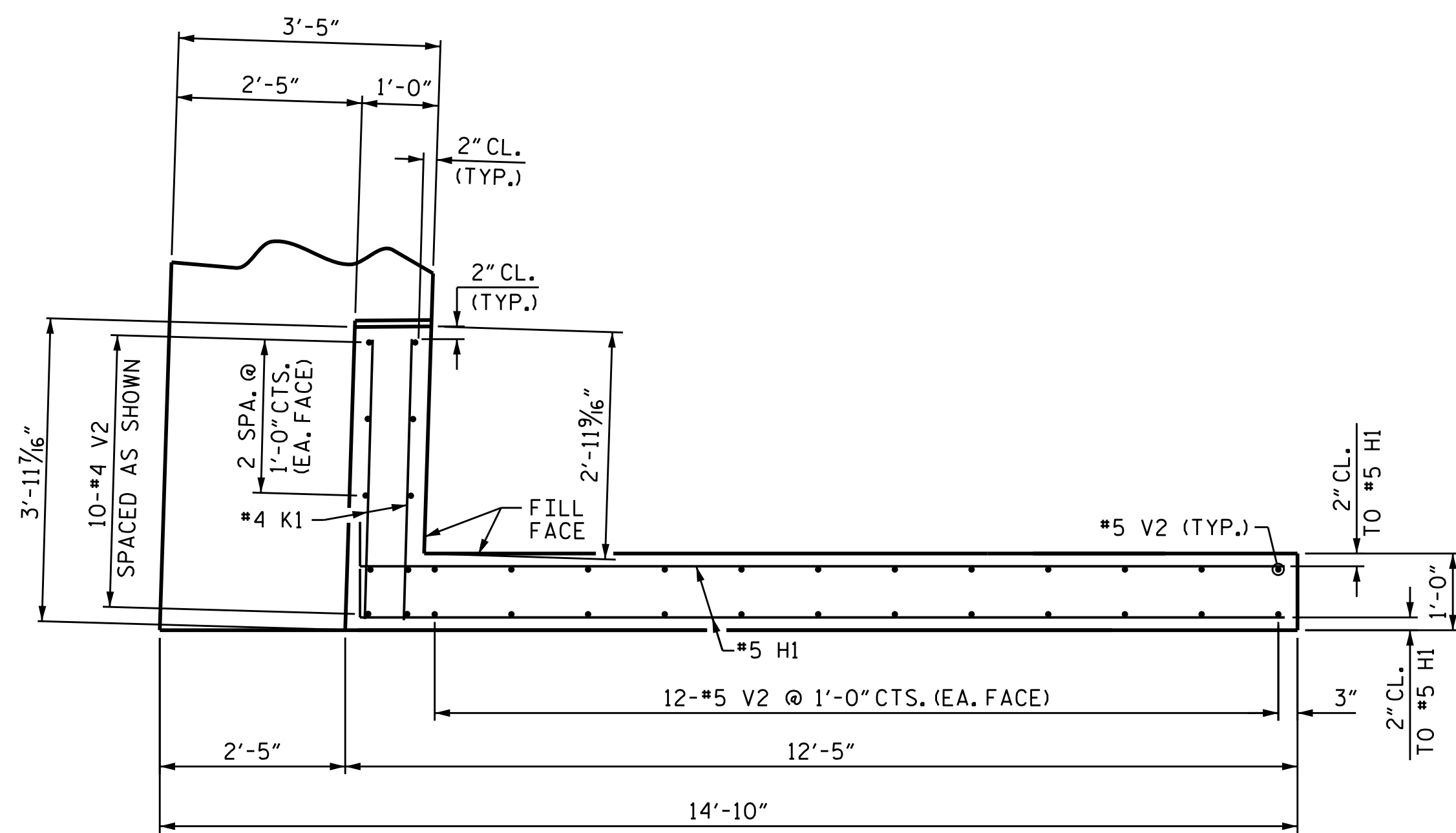

PLAN OF LEFT WING

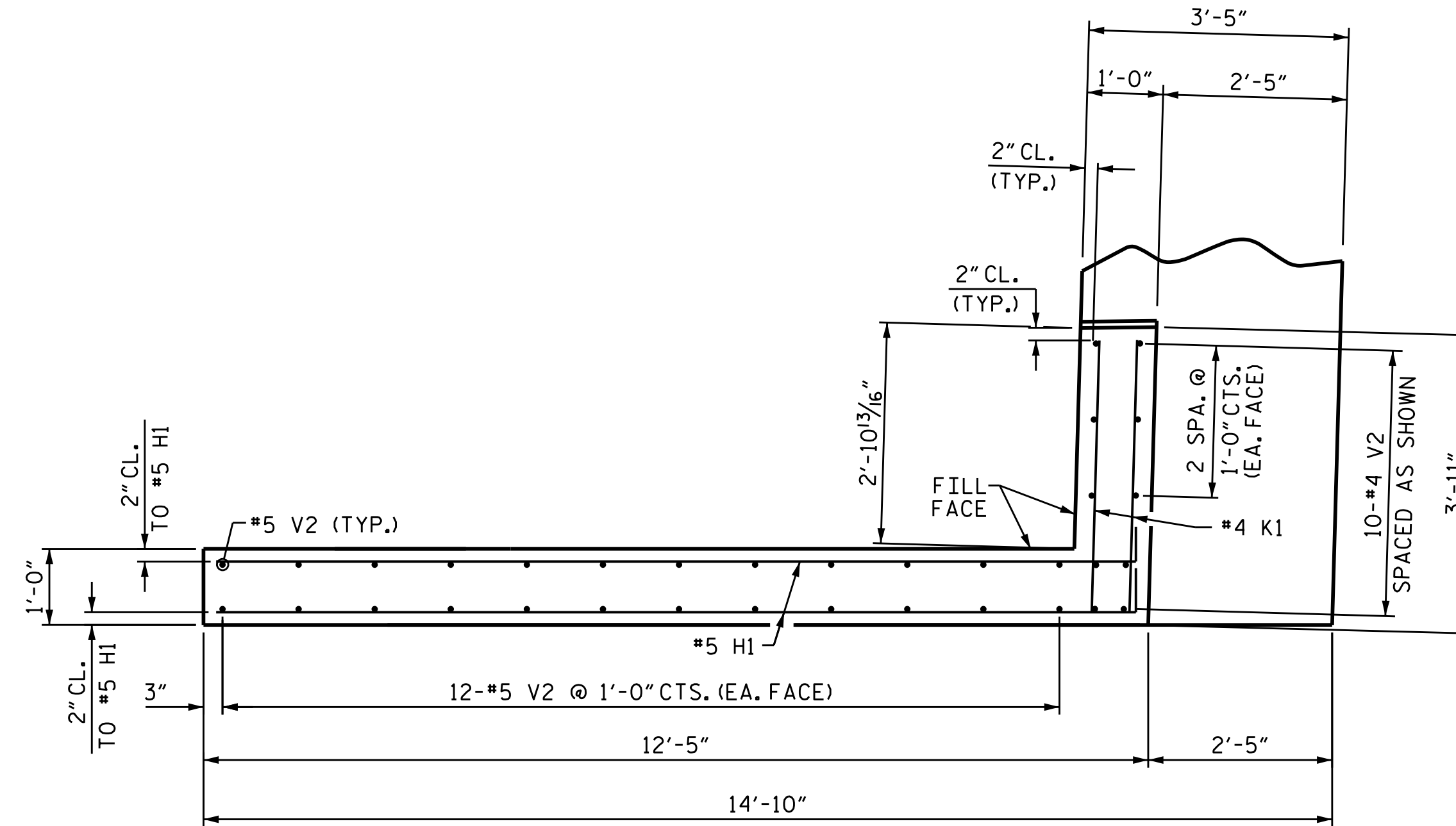

PLAN OF RIGHT WING

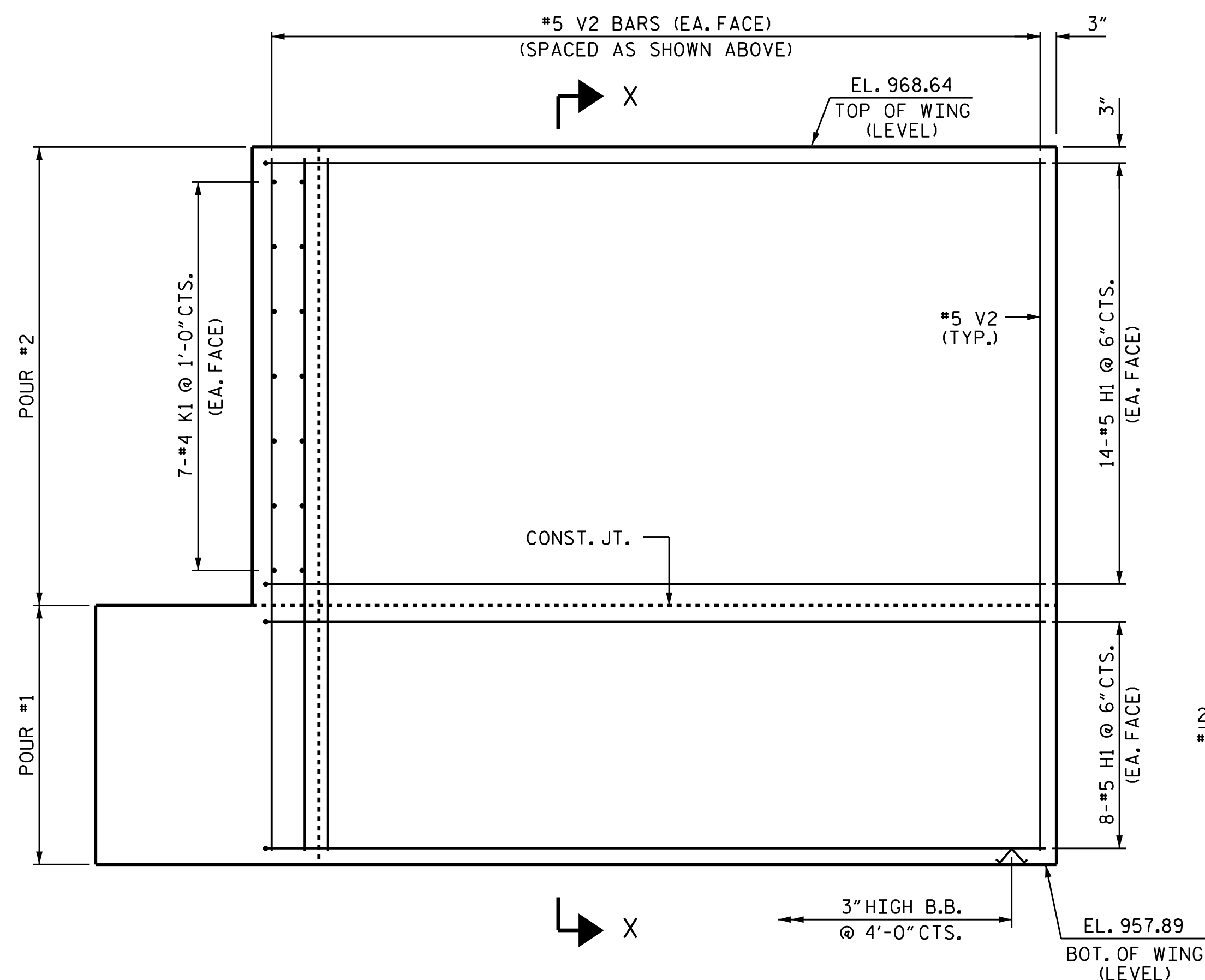

ELEVATION OF LEFT WING

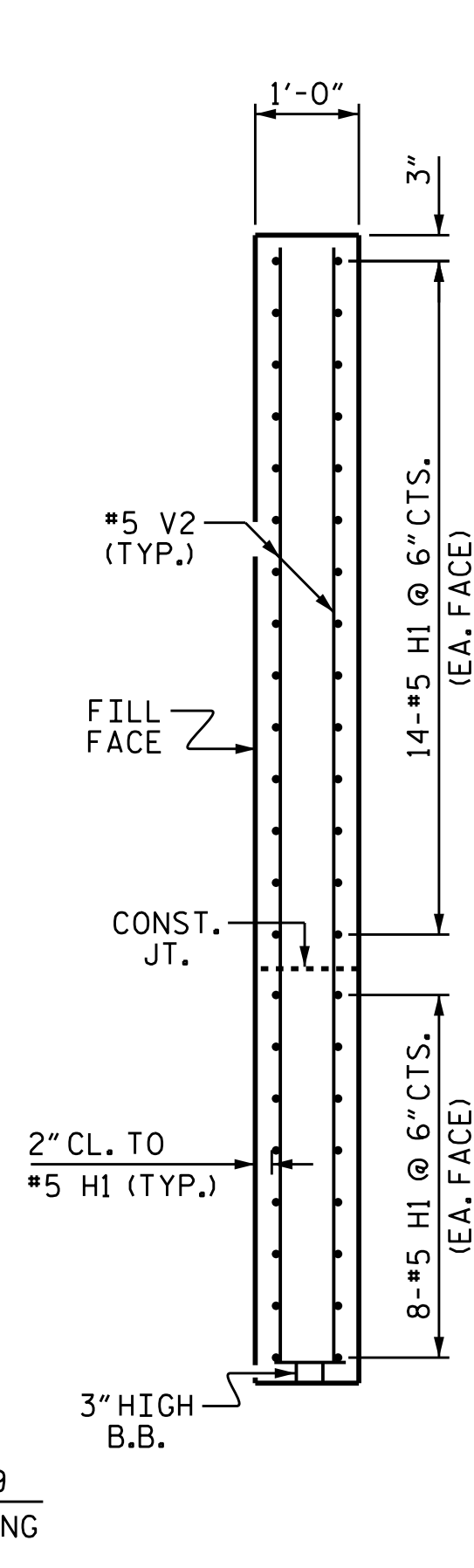

SECTION X-X

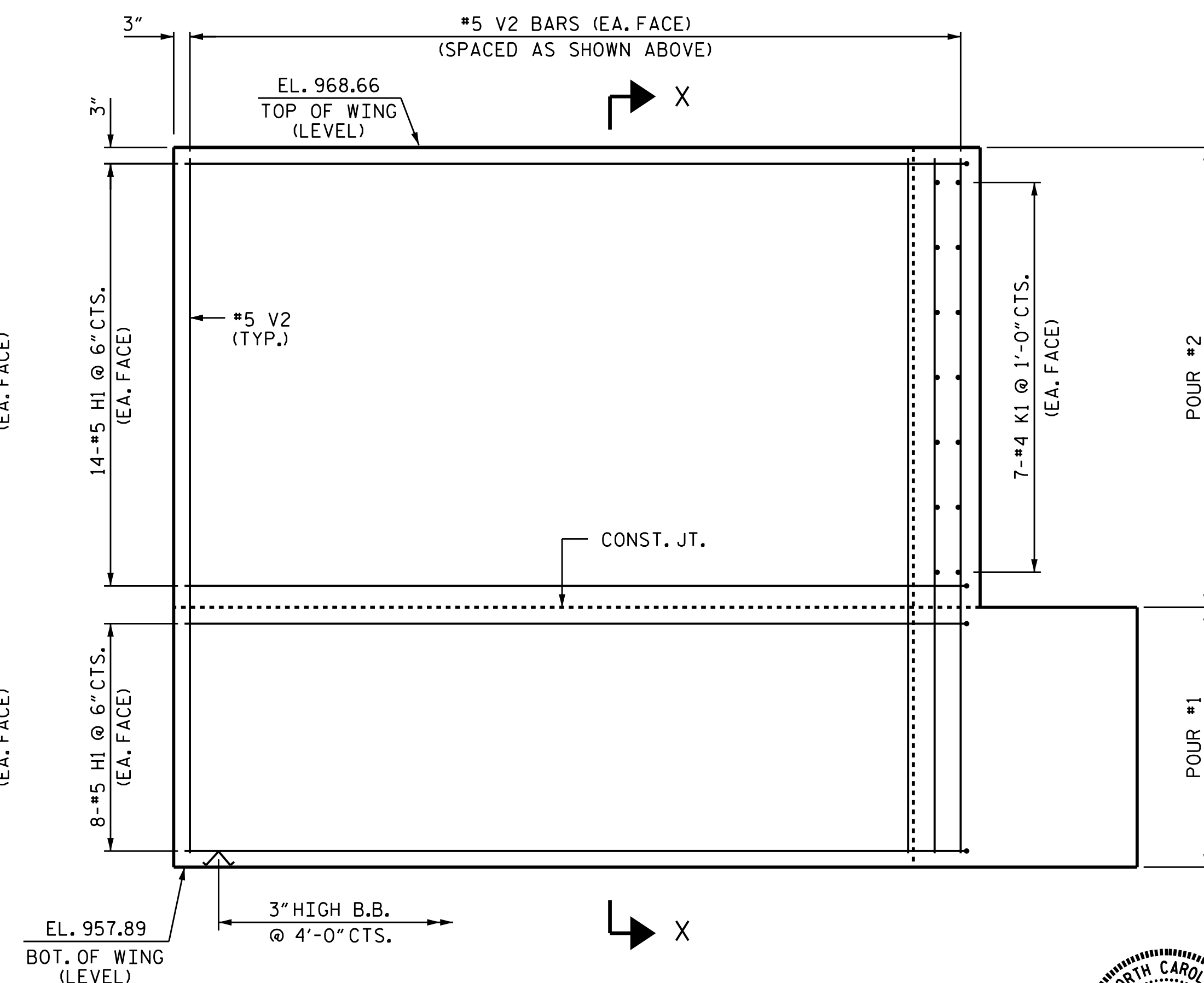

ELEVATION OF RIGHT WING

PROJECT NO. U-2579C
FORSYTH COUNTY
 STATION: 29+24.97 -Y1-

SHEET 2 OF 3

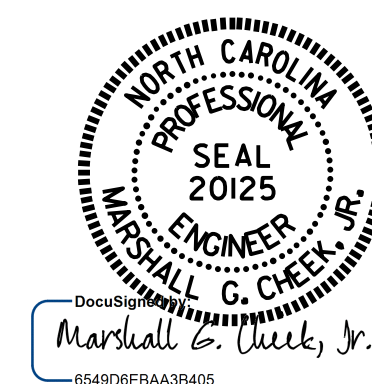

STATE OF NORTH CAROLINA
 DEPARTMENT OF TRANSPORTATION
 RALEIGH
 SUBSTRUCTURE
 INTEGRAL
 END BENT 1

DRAWN BY : N.D. AIUTO DATE : 4/6/16
 CHECKED BY : K.D. LAYNE DATE : 4/14/16
 DESIGN ENGINEER OF RECORD: H.A. LOCKLEAR DATE : 6/2017

DOCUMENT NOT CONSIDERED
 FINAL UNLESS ALL
 SIGNATURES COMPLETED

REVISIONS						SHEET NO.	
NO.	BY:	DATE:	NO.	BY:	DATE:	S1-22	
1			3			TOTAL SHEETS	32
2			4				

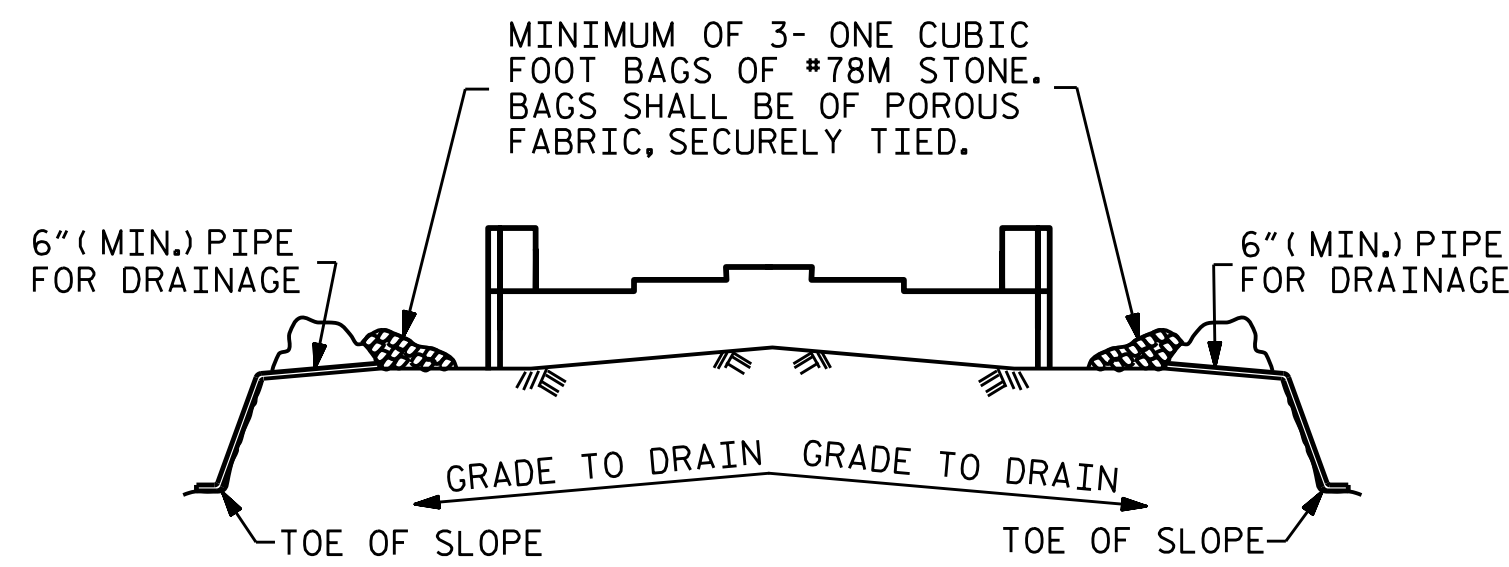

BAGGED STONE AND PIPE SHALL BE PLACED IMMEDIATELY AFTER COMPLETION OF END BENT EXCAVATION. PIPE MAY BE EITHER CONCRETE, CORRUGATED STEEL, CORRUGATED ALUMINUM ALLOY, OR CORRUGATED PLASTIC. PERFORATED PIPE WILL NOT BE ALLOWED.

BAGGED STONE SHALL REMAIN IN PLACE UNTIL THE ENGINEER DIRECTS THAT IT BE REMOVED. THE CONTRACTOR SHALL REMOVE AND DISPOSE OF SILT ACCUMULATIONS AT BAGGED STONE WHEN SO DIRECTED BY THE ENGINEER. BAGS SHALL BE REMOVED AND REPLACED WHENEVER THE ENGINEER DETERMINES THAT THEY HAVE DETERIORATED AND LOST THEIR EFFECTIVENESS.

NO SEPARATE PAYMENT WILL BE MADE FOR THIS WORK AND THE ENTIRE COST OF THIS WORK SHALL BE INCLUDED IN THE UNIT CONTRACT PRICE BID FOR THE SEVERAL PAY ITEMS.

TEMPORARY DRAINAGE AT END BENT

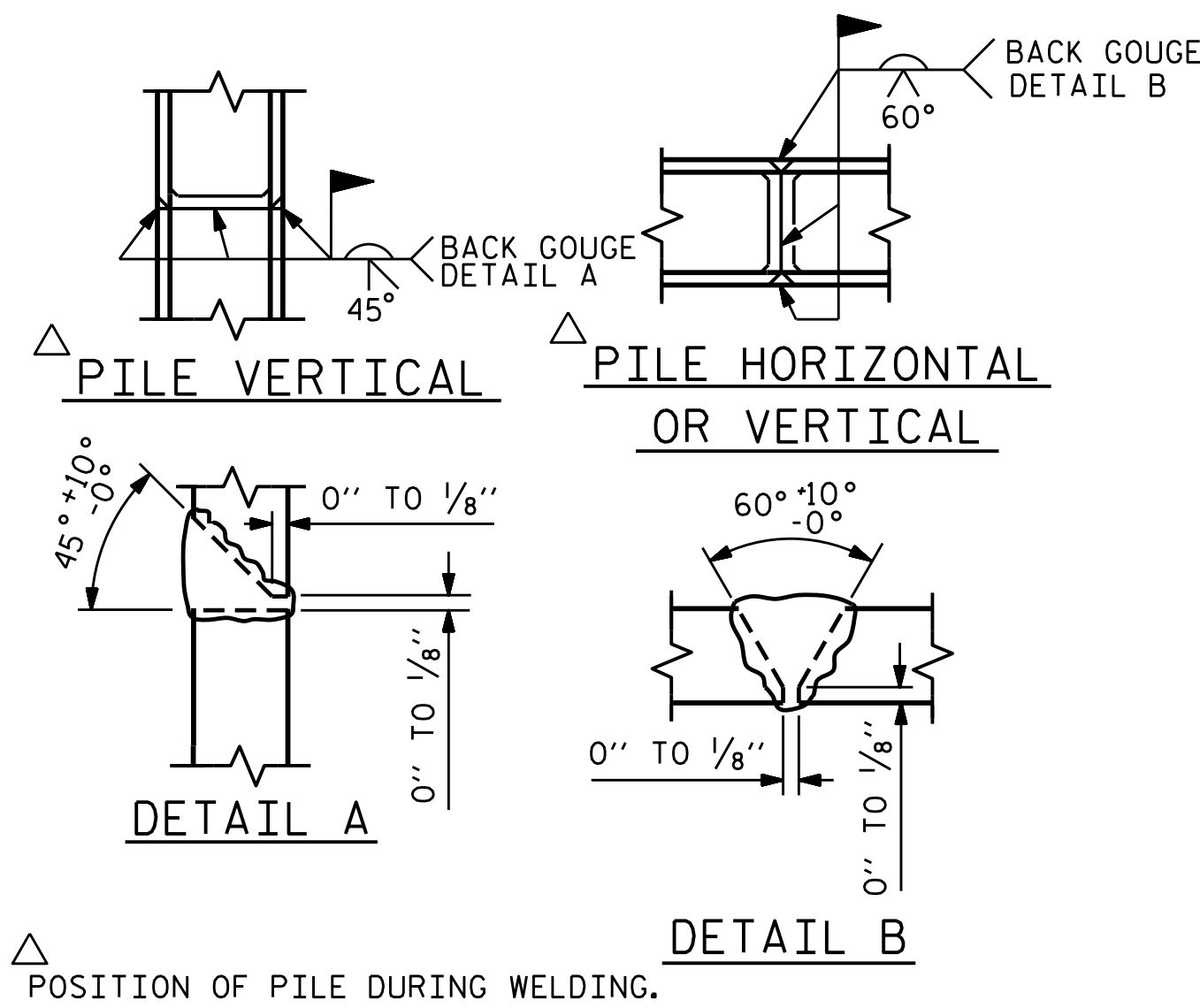

PILE SPLICE DETAILS

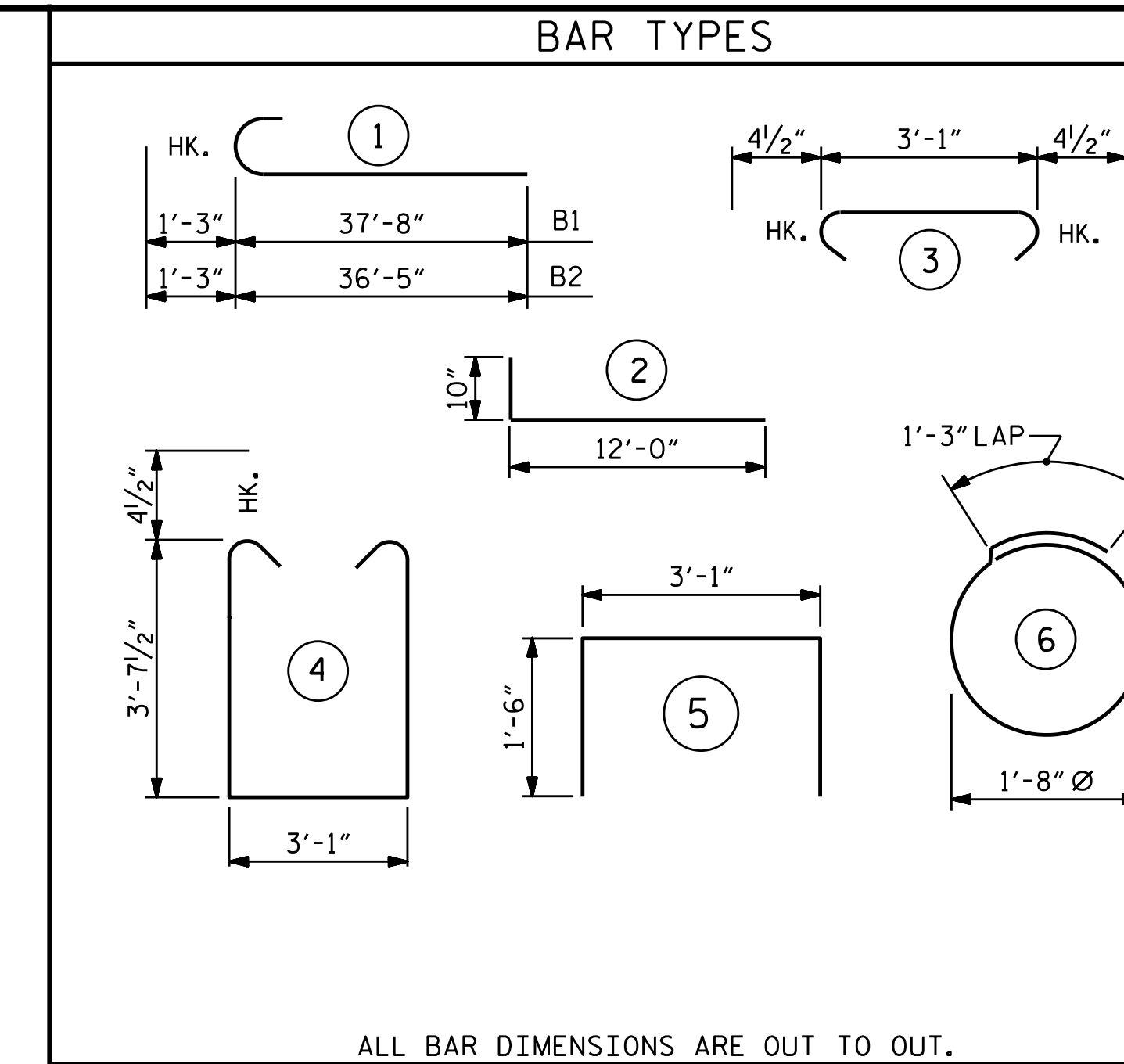

BILL OF MATERIAL					
END BENT 1					
BAR NO.	NO.	SIZE	TYPE	LENGTH	WEIGHT
B1	8	#9	1	38'-11"	1059
B2	8	#9	1	37'-8"	1025
B3	30	#4	STR	23'-10"	478
B4	17	#4	STR	3'-1"	35
B5	4	#4	STR	13'-8"	37
H1	88	#5	2	12'-10"	1178
K1	28	#4	STR	3'-6"	65
S1	88	#4	4	11'-1"	652
S2	88	#4	3	3'-10"	225
S3	33	#4	6	6'-6"	143
U1	10	#4	5	6'-1"	41
V1	88	#4	STR	6'-0"	353
V2	68	#5	STR	10'-9"	762
REINFORCING STEEL					LBS. 6,053
CLASS A CONCRETE					
POUR #1 CAP, LOWER PART OF WINGS, & COLLARS					C.Y. 45.0
POUR #2 UPPER PART OF WINGS					C.Y. 7.7
TOTAL					C.Y. 52.7
HP 12 X 53 STEEL PILES					
NO.: 11					LIN. FT. 470
PILE DRIVING EQUIPMENT SETUP FOR HP 12 X 53 STEEL PILES					
					EACH 11

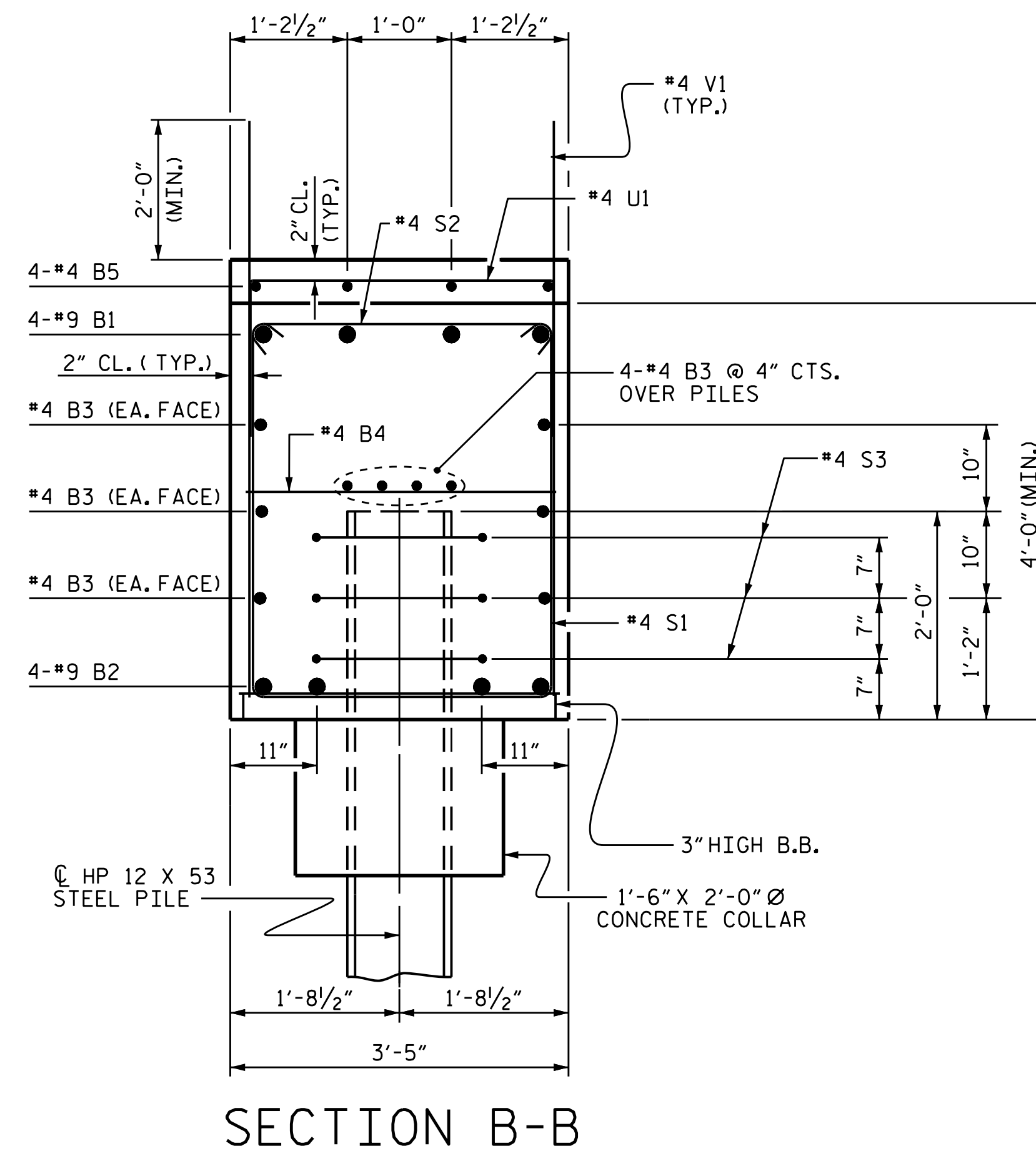
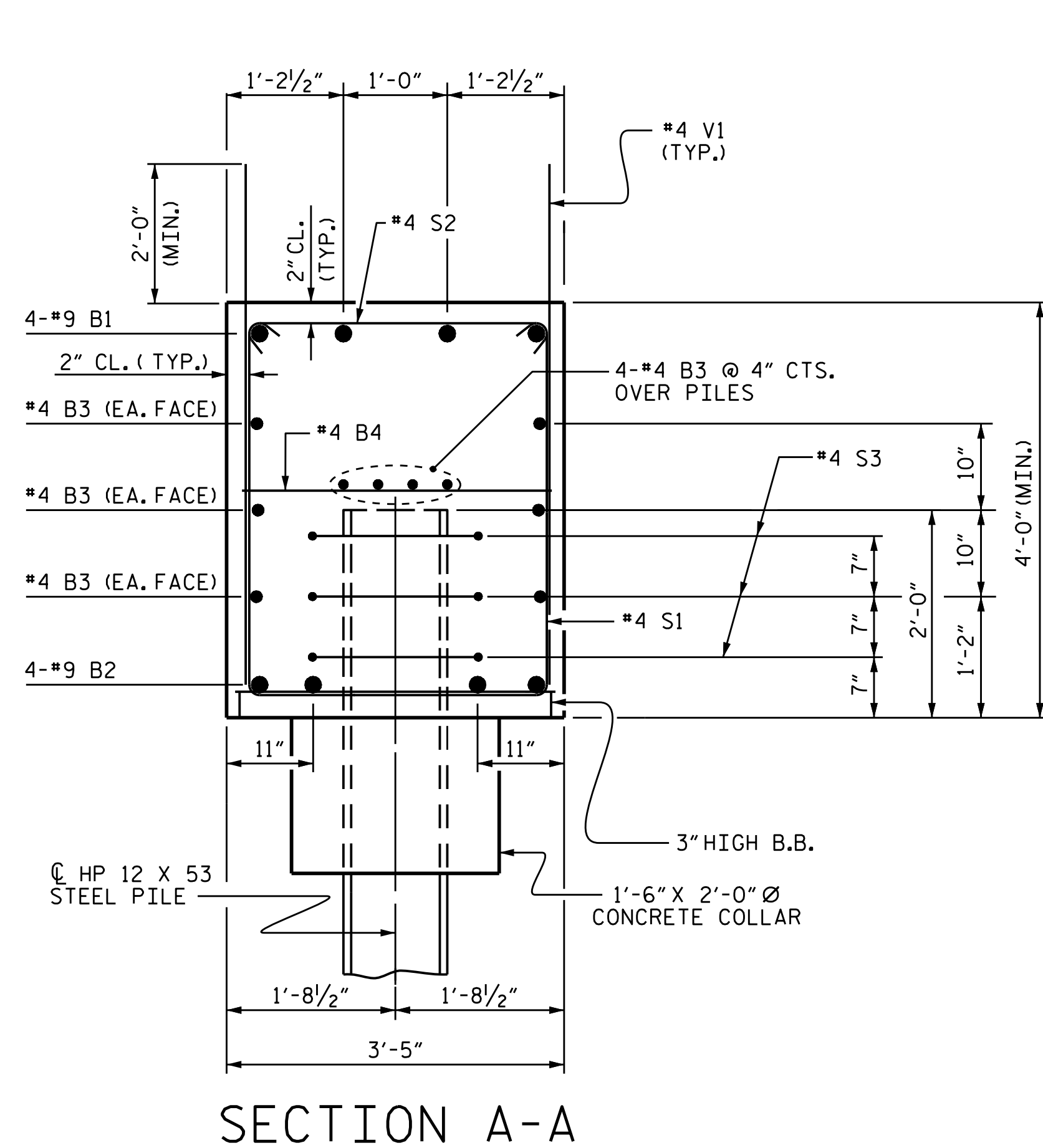

PROJECT NO. U-2579C
 FORSYTH COUNTY
 STATION: 29+24.97 -Y1-
 SHEET 3 OF 3

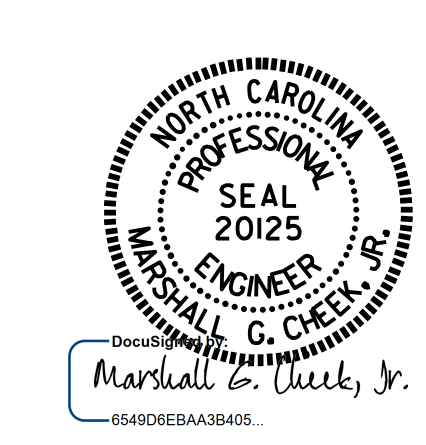

STATE OF NORTH CAROLINA					
DEPARTMENT OF TRANSPORTATION					
RALEIGH					
SUBSTRUCTURE					
INTEGRAL END BENT 1					
REVISIONS					
NO.	BY:	DATE:	NO.	BY:	DATE:
1			3		
2			4		
SHEET NO.					S1-23
TOTAL SHEETS					32

DRAWN BY: N.D. AIUTO DATE: 4/6/16
 CHECKED BY: K.D. LAYNE DATE: 4/14/16
 DESIGN ENGINEER OF RECORD: H.A. LOCKLEAR DATE: 6/2017

DOCUMENT NOT CONSIDERED FINAL UNLESS ALL SIGNATURES COMPLETED

NOTES

STIRRUPS AND "U" BARS IN CAP MAY BE SHIFTED AS NECESSARY TO CLEAR ANCHOR BOLTS.
 HOOKS ON "V" BARS MAY BE TURNED AS NECESSARY FOR PLACING REINFORCING STEEL.

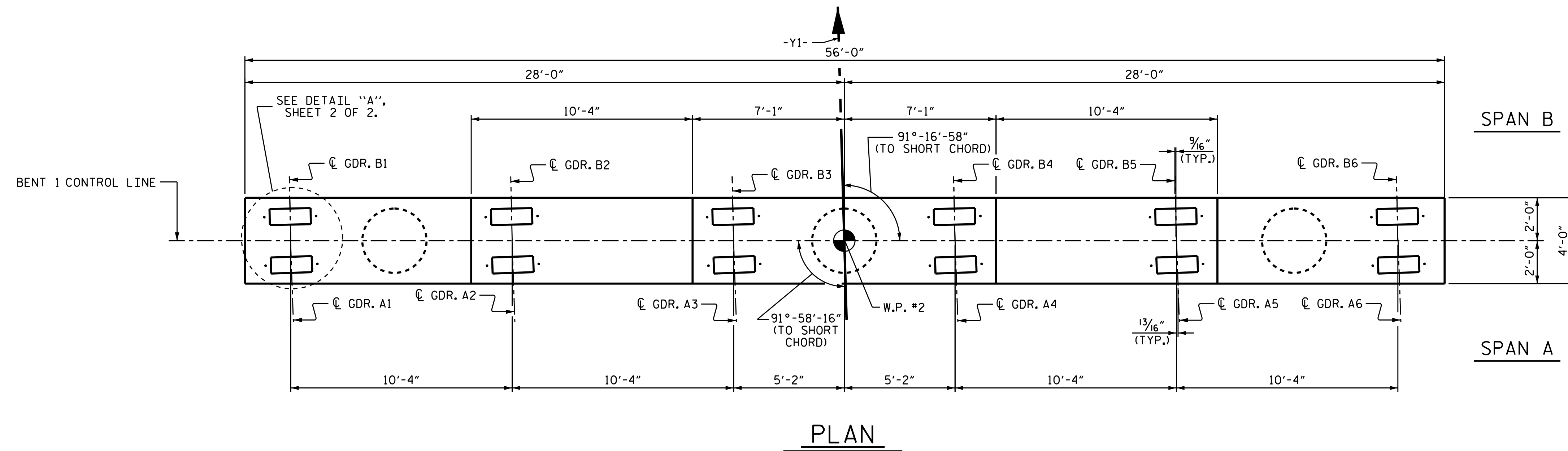

PLAN

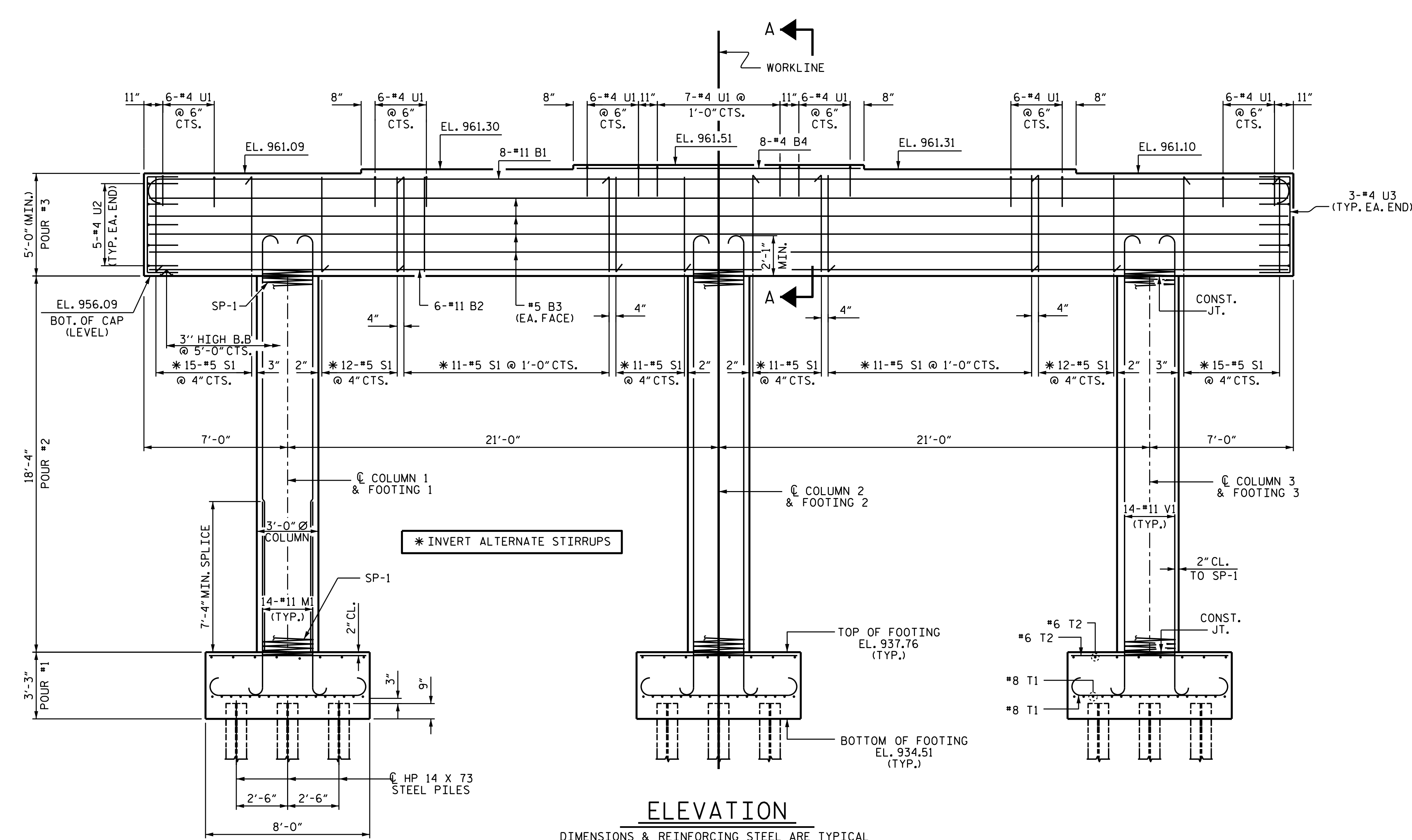

ELEVATION

DIMENSIONS & REINFORCING STEEL ARE TYPICAL FOR EACH COLUMN & FOOTING.

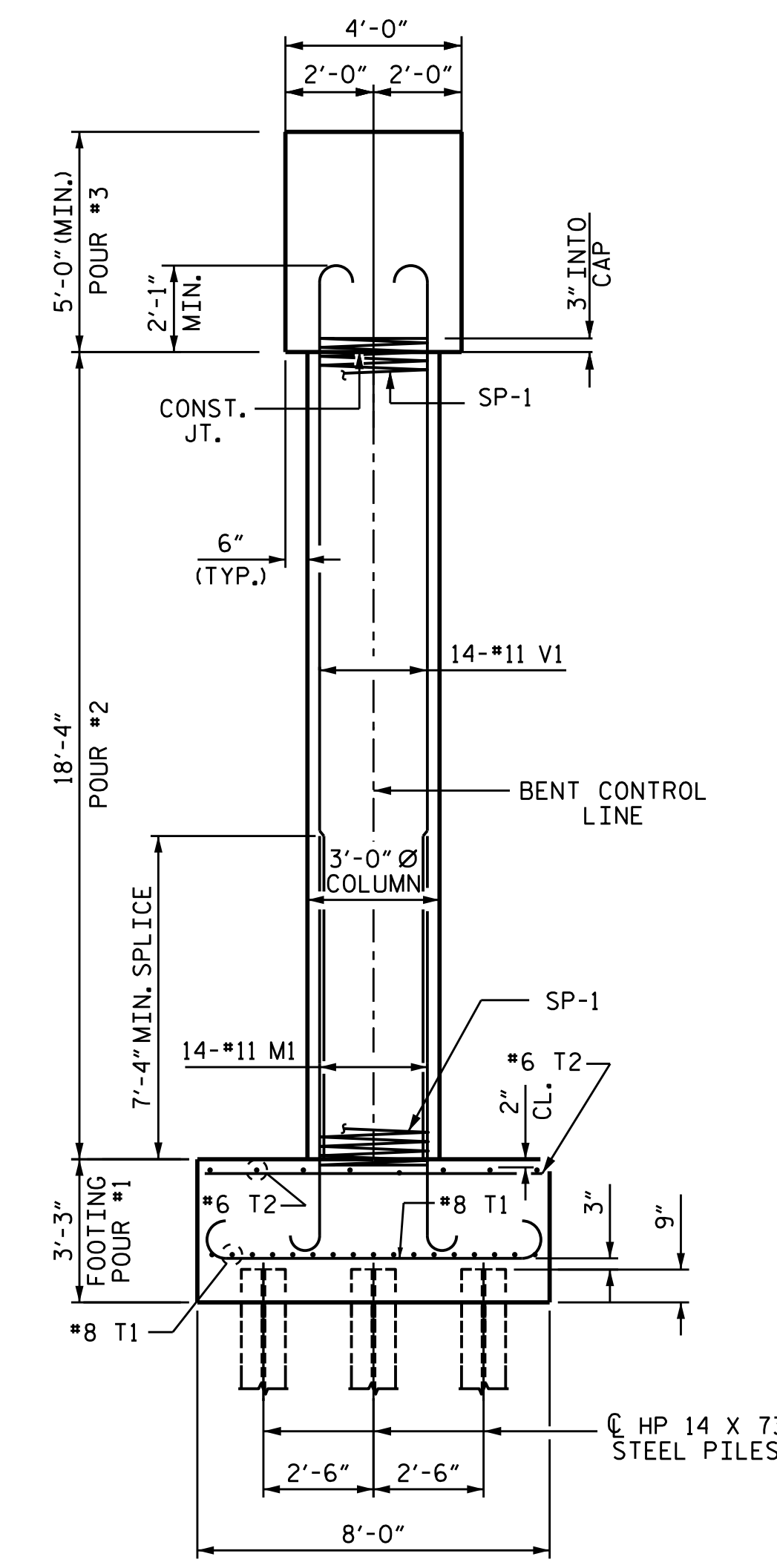

END ELEVATION

PROJECT NO. U-2579C
 FORSYTH COUNTY
 STATION: 29+24.97 -L-

SHEET 1 OF 2



STATE OF NORTH CAROLINA
 DEPARTMENT OF TRANSPORTATION
 RALEIGH

SUBSTRUCTURE

BENT 1

DRAWN BY : N.D. AIUTO DATE : 4/5/16
 CHECKED BY : K.D. LAYNE DATE : 4/21/16
 DESIGN ENGINEER OF RECORD: H.A. LOCKLEAR DATE : 6/2017

DOCUMENT NOT CONSIDERED FINAL UNLESS ALL SIGNATURES COMPLETED

REVISIONS						SHEET NO.
NO.	BY:	DATE:	NO.	BY:	DATE:	S1-24
1			3			TOTAL SHEETS
2			4			32

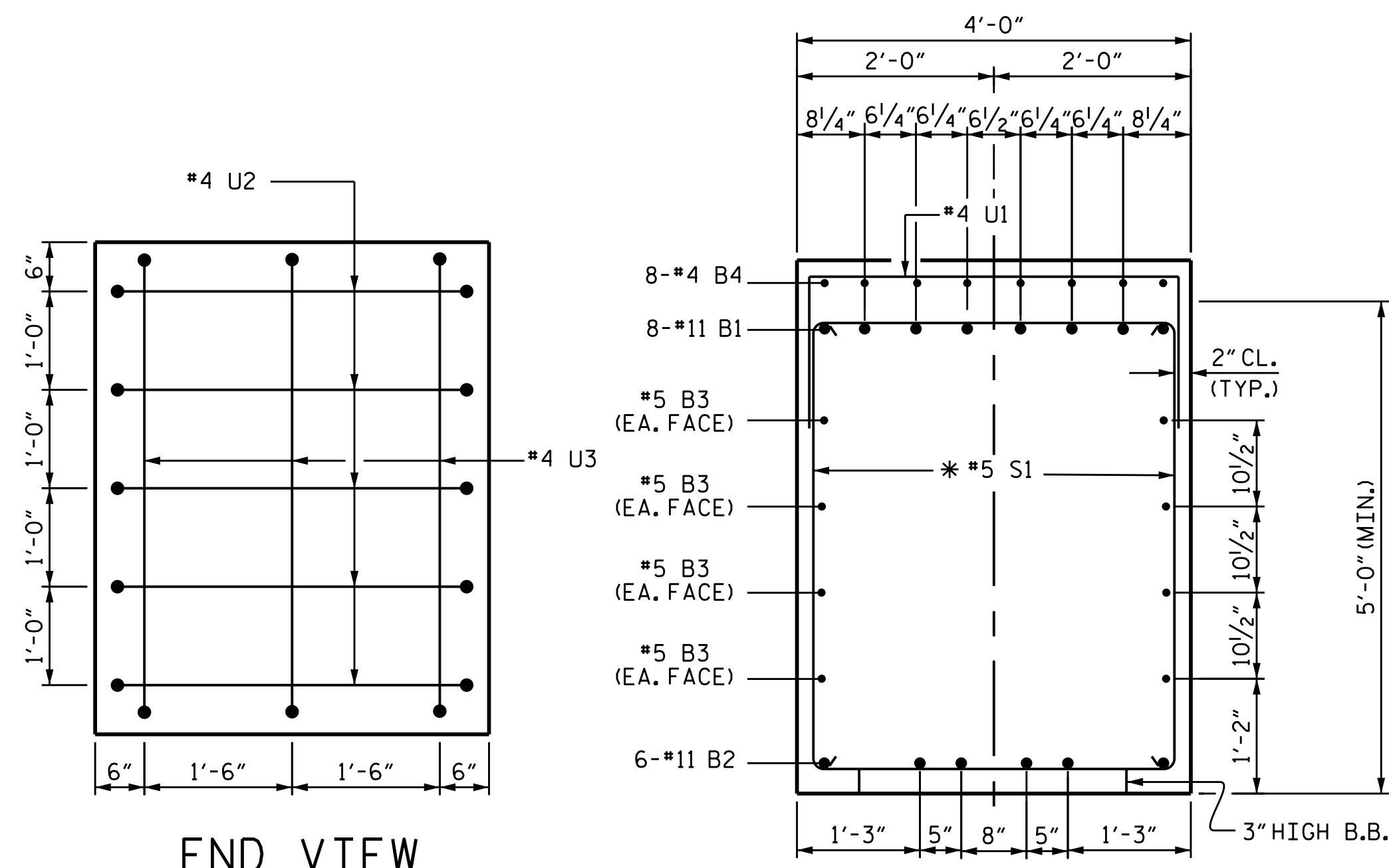

SECTION A-A
* INVERT ALTERNATE STIRRUPS

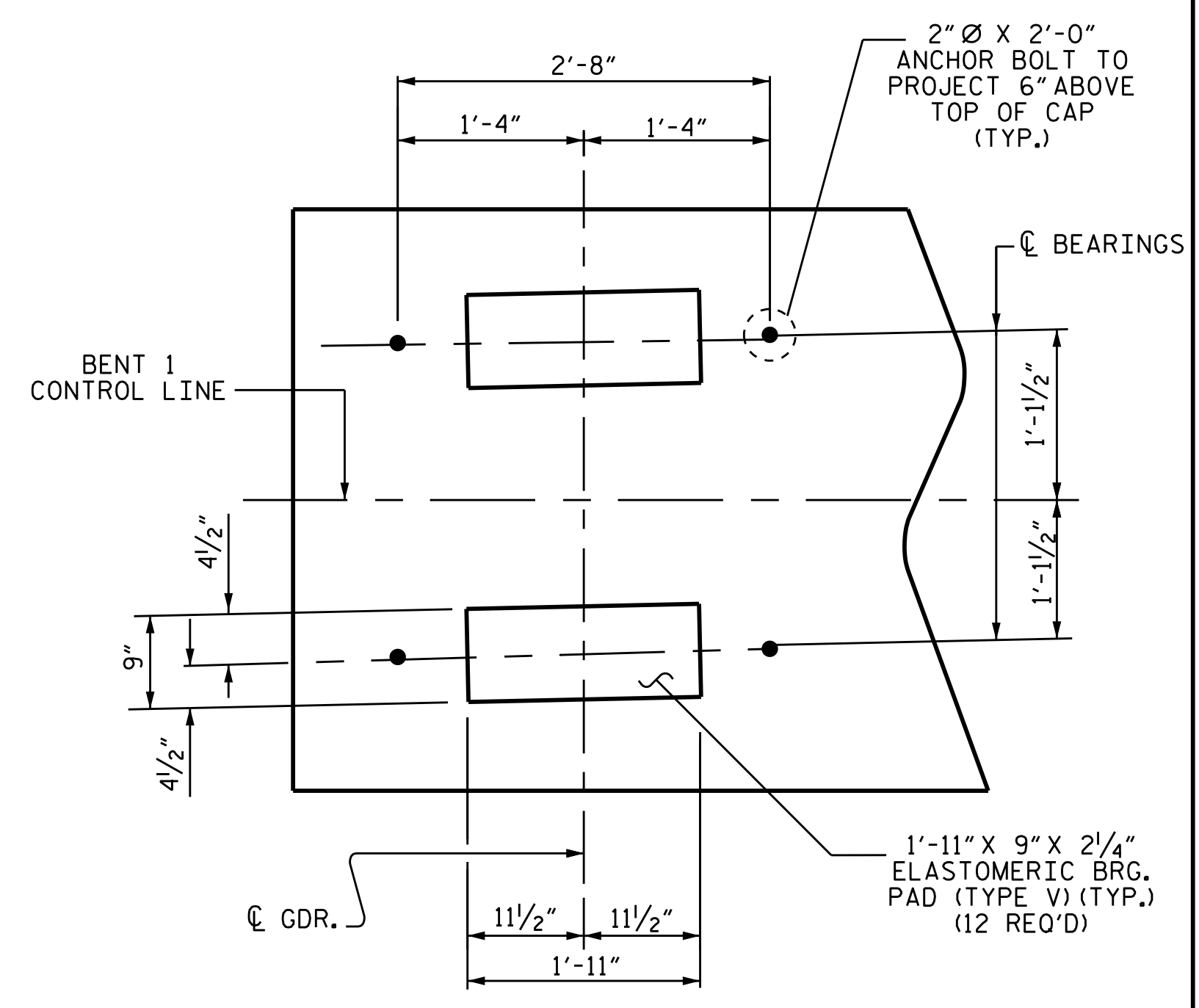

DETAIL "A"
DIMENSIONS ARE TYPICAL FOR EACH BEARING.

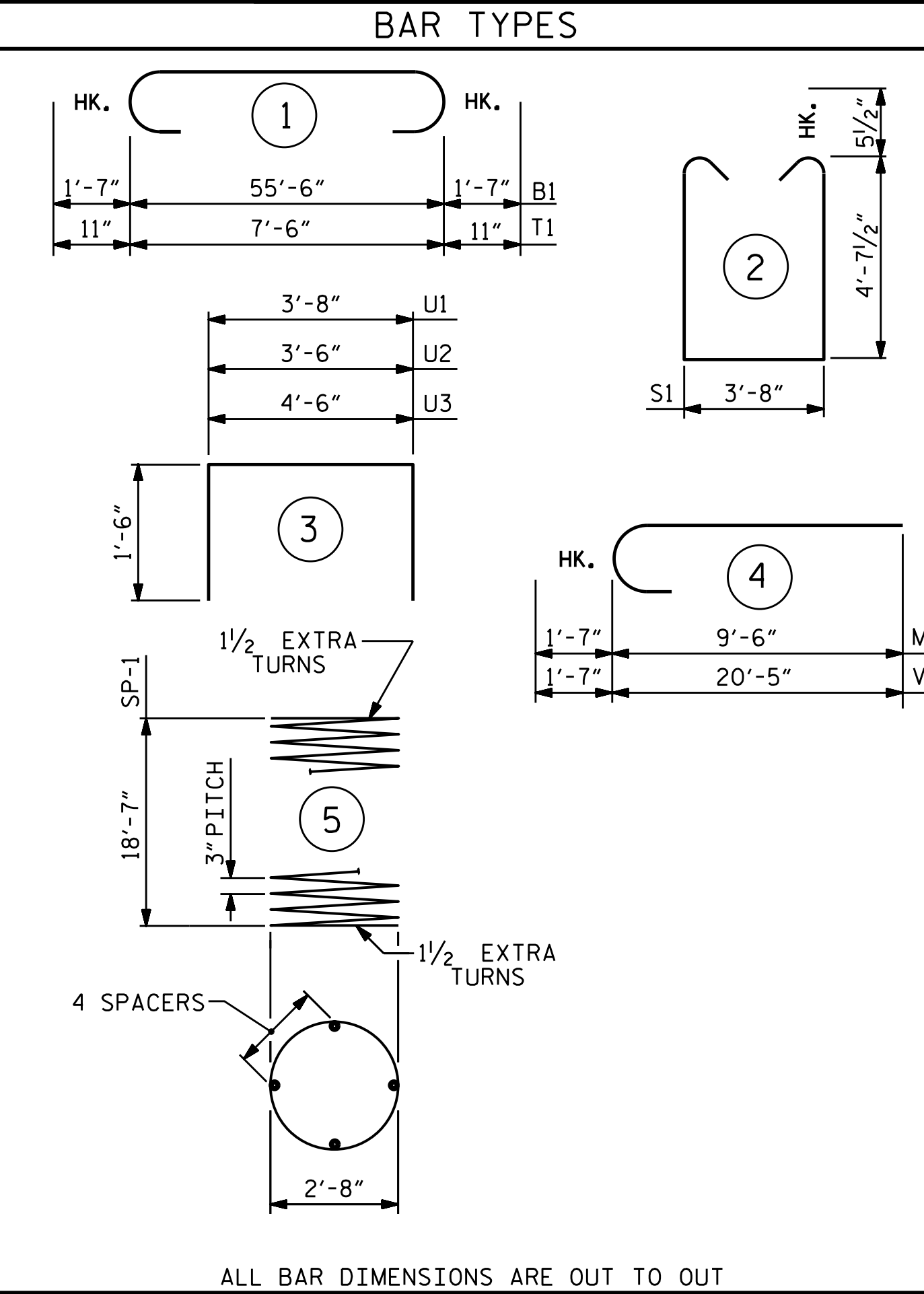

BILL OF MATERIAL					
BAR	NO.	SIZE	TYPE	LENGTH	WEIGHT
B1	8	#11	1	58'-8"	2494
B2	6	#11	STR	55'-8"	1775
B3	8	#5	STR	55'-8"	464
B4	8	#4	STR	13'-10"	74
M1	42	#11	4	11'-1"	2473
S1	98	#5	2	13'-10"	1414
T1	102	#8	1	9'-4"	2542
T2	48	#6	STR	7'-8"	553
U1	43	#4	3	6'-8"	191
U2	10	#4	3	6'-6"	43
U3	6	#4	3	7'-6"	30
V1	42	#11	4	22'-0"	4909
REINFORCING STEEL				LBS.	16,962
SP-1	3	*	5	639'-5"	1281
SPIRAL COLUMN REINFORCING STEEL				LBS.	1,281
* THE SP-1 SPIRAL REINFORCING STEEL SHALL BE W20 OR D-20 COLD DRAWN WIRE OR #4 PLAIN OR DEFORMED BAR.					
CLASS A CONCRETE					
POUR #1 (FOOTINGS)				C.Y.	23.1
POUR #2 (COLUMNS)				C.Y.	14.4
POUR #3 (CAP)				C.Y.	42.9
TOTAL CLASS A CONCRETE				C.Y.	80.4
FOUNDATION EXCAVATION				LUMP SUM	
HP 14 X 73 STEEL PILES				LIN. FT.	480
No.: 24					
STEEL PILE POINTS				EA.	24
PILE DRIVING EQUIPMENT SETUP FOR HP 14 X 73 STEEL PILES				EA.	24

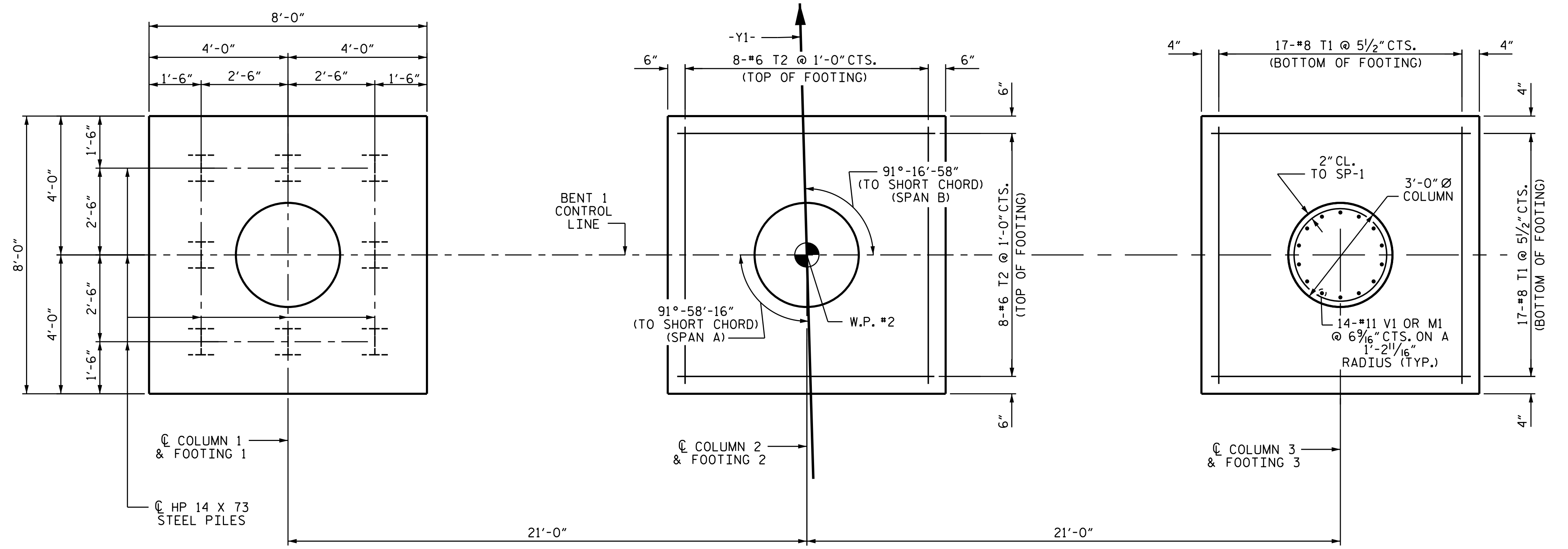

PLAN OF FOOTINGS AND COLUMNS
DIMENSIONS AND REINFORCING STEEL ARE TYPICAL FOR EACH COLUMN & FOOTING

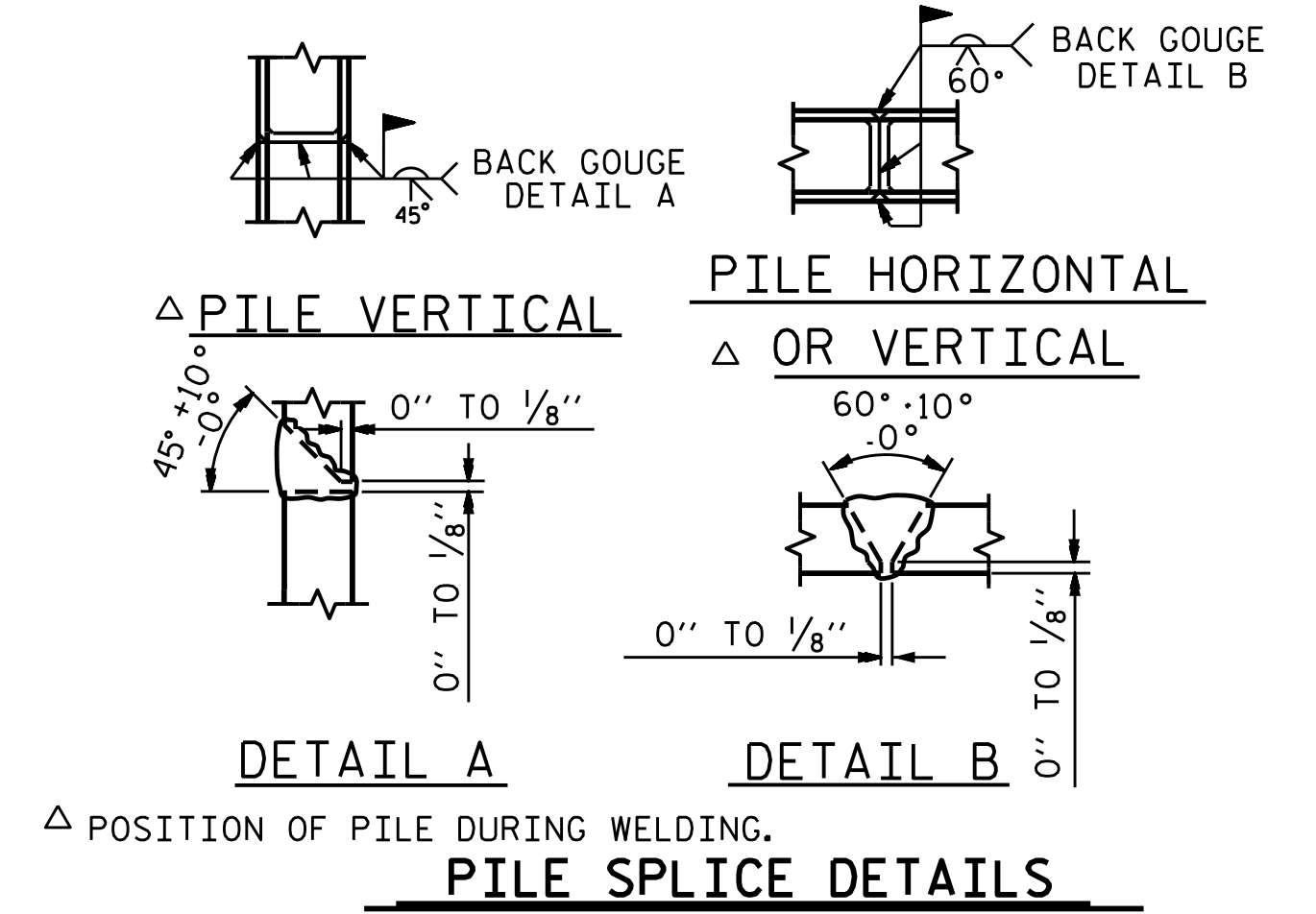

PILE SPLICE DETAILS
PROJECT NO. U-2579C
FORSYTH COUNTY
STATION: 29+24.97 -Y1-

DRAWN BY: N.D. AIUTO DATE: 4/5/16
CHECKED BY: K.D. LAYNE DATE: 4/21/16
DESIGN ENGINEER OF RECORD: H.A. LOCKLEAR DATE: 6/20/17

DOCUMENT NOT CONSIDERED FINAL UNLESS ALL SIGNATURES COMPLETED

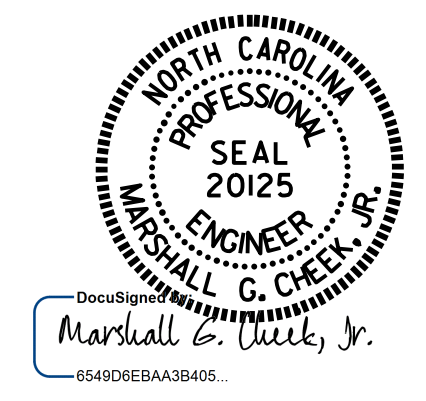

REVISIONS					SHEET NO.
NO.	BY:	DATE:	NO.	DATE:	S1-25
1			3		TOTAL SHEETS
2			4		32

NOTES

THE TOP SURFACE OF THE END BENT CAP, EXCEPT THE BEARING AREA, SHALL BE RAKED TO A DEPTH OF 1/4".

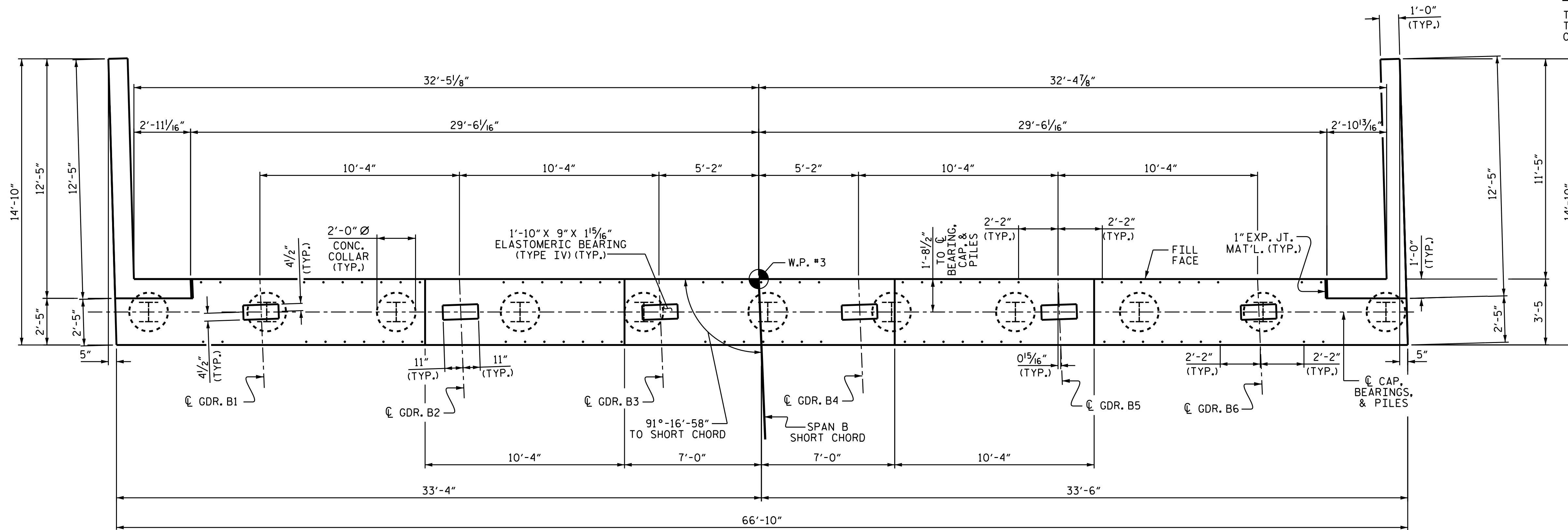

PLAN

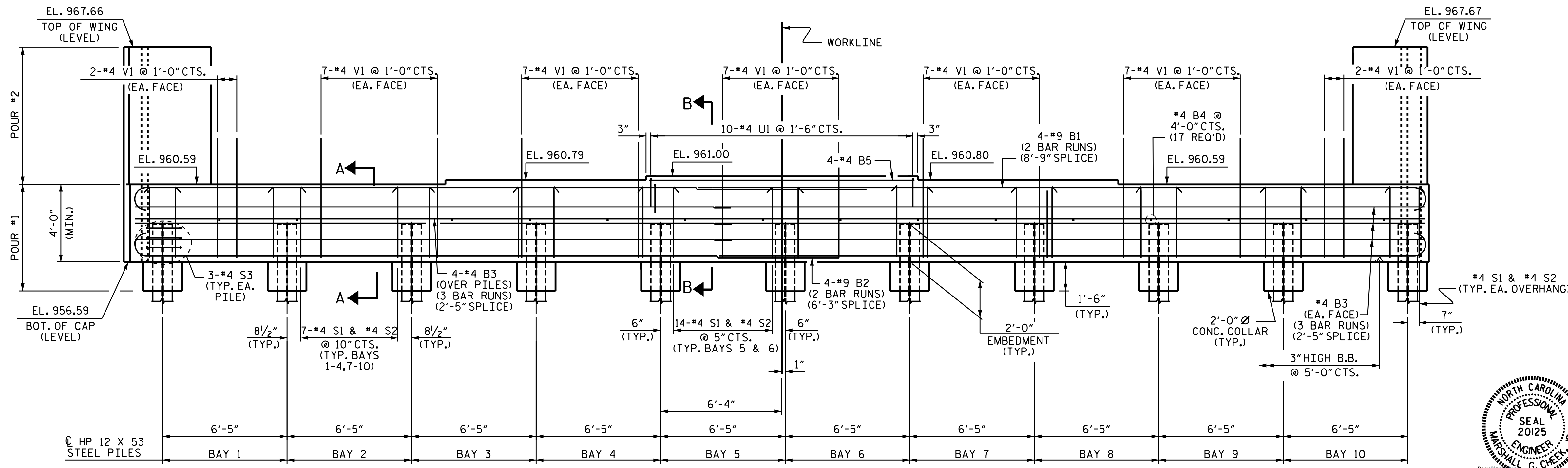

ELEVATION

PROJECT NO. U-2579C
 FORSYTH COUNTY
 STATION: 29+24.97 -Y1-
 SHEET 1 OF 3

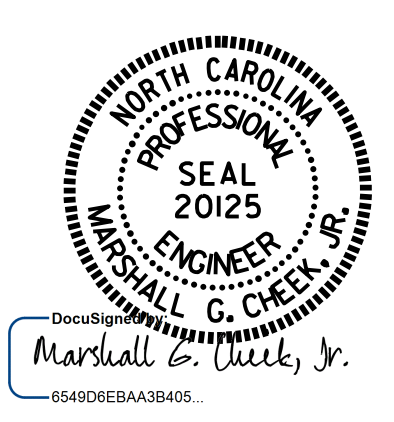

STATE OF NORTH CAROLINA
 DEPARTMENT OF TRANSPORTATION
 RALEIGH

SUBSTRUCTURE
 INTEGRAL
 END BENT 2

DRAWN BY : N.D. AIUTO DATE : 3/21/22
 CHECKED BY : K.D. LAYNE DATE : 4/14/2016
 DESIGN ENGINEER OF RECORD : H.A. LOCKLEAR DATE : 6/2017

DOCUMENT NOT CONSIDERED
 FINAL UNLESS ALL
 SIGNATURES COMPLETED

REVISIONS						SHEET NO.
NO.	BY:	DATE:	NO.	BY:	DATE:	S1-26
1			3			TOTAL SHEETS
2			4			32

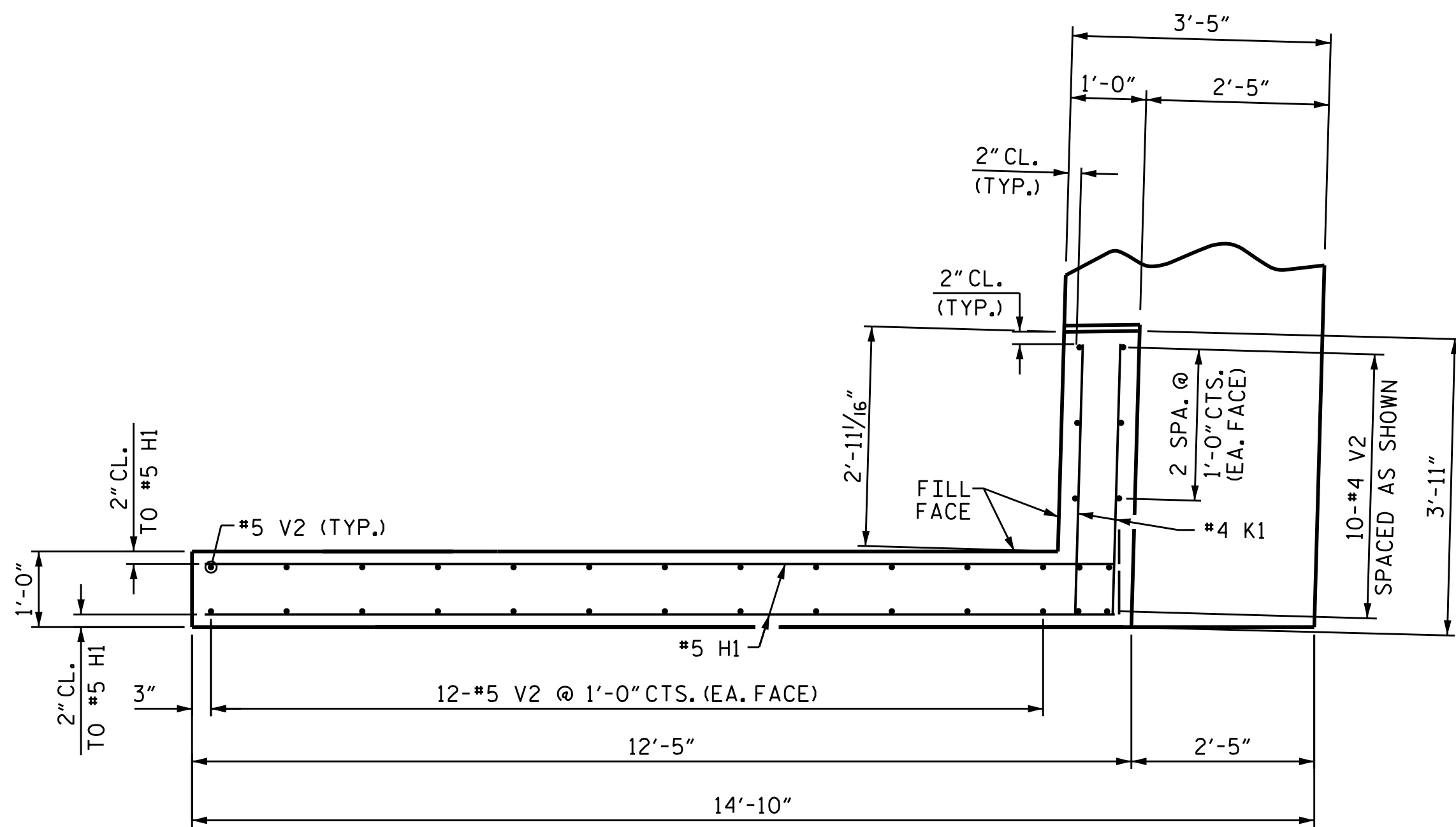

PLAN OF LEFT WING

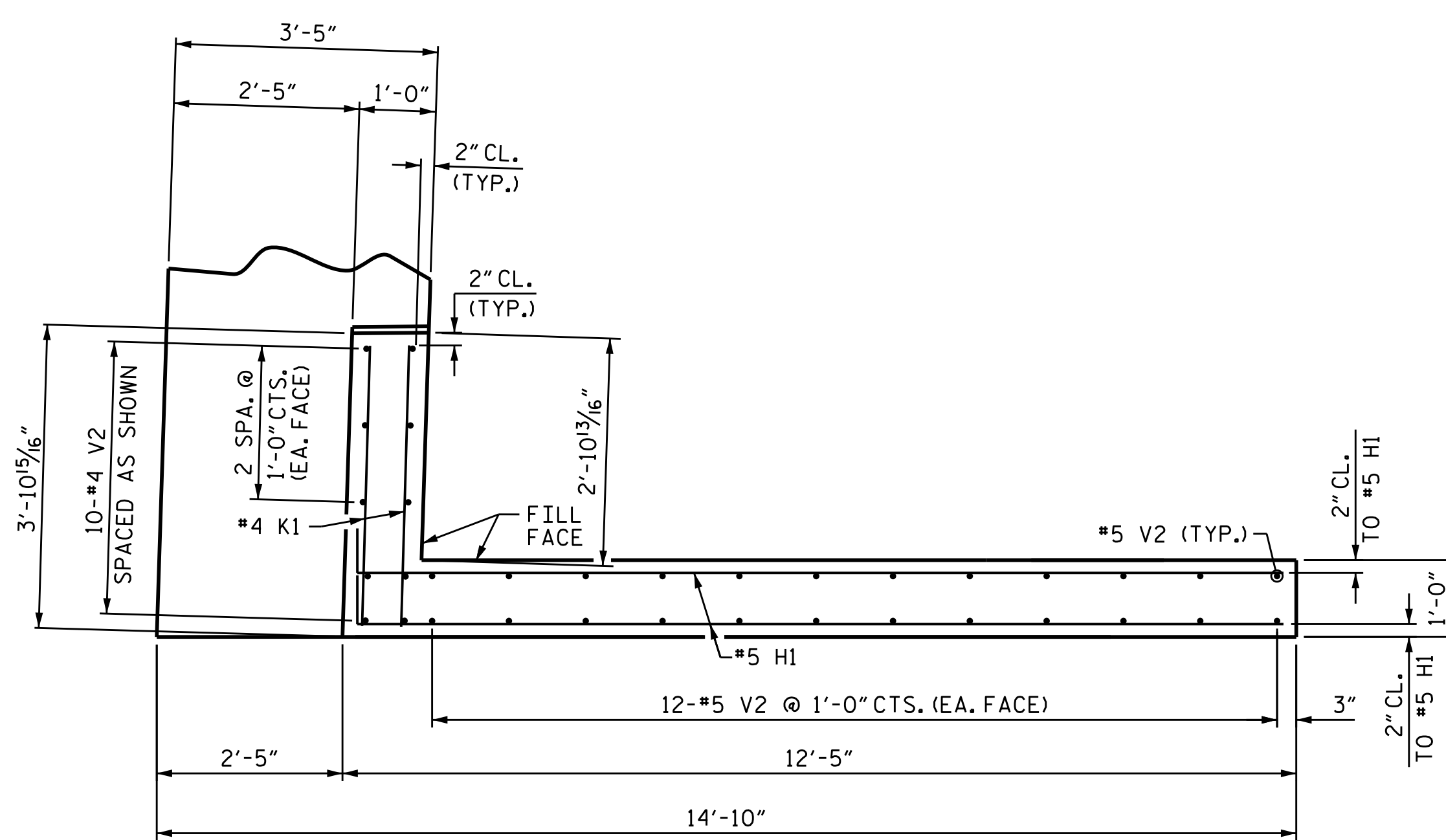

PLAN OF RIGHT WING

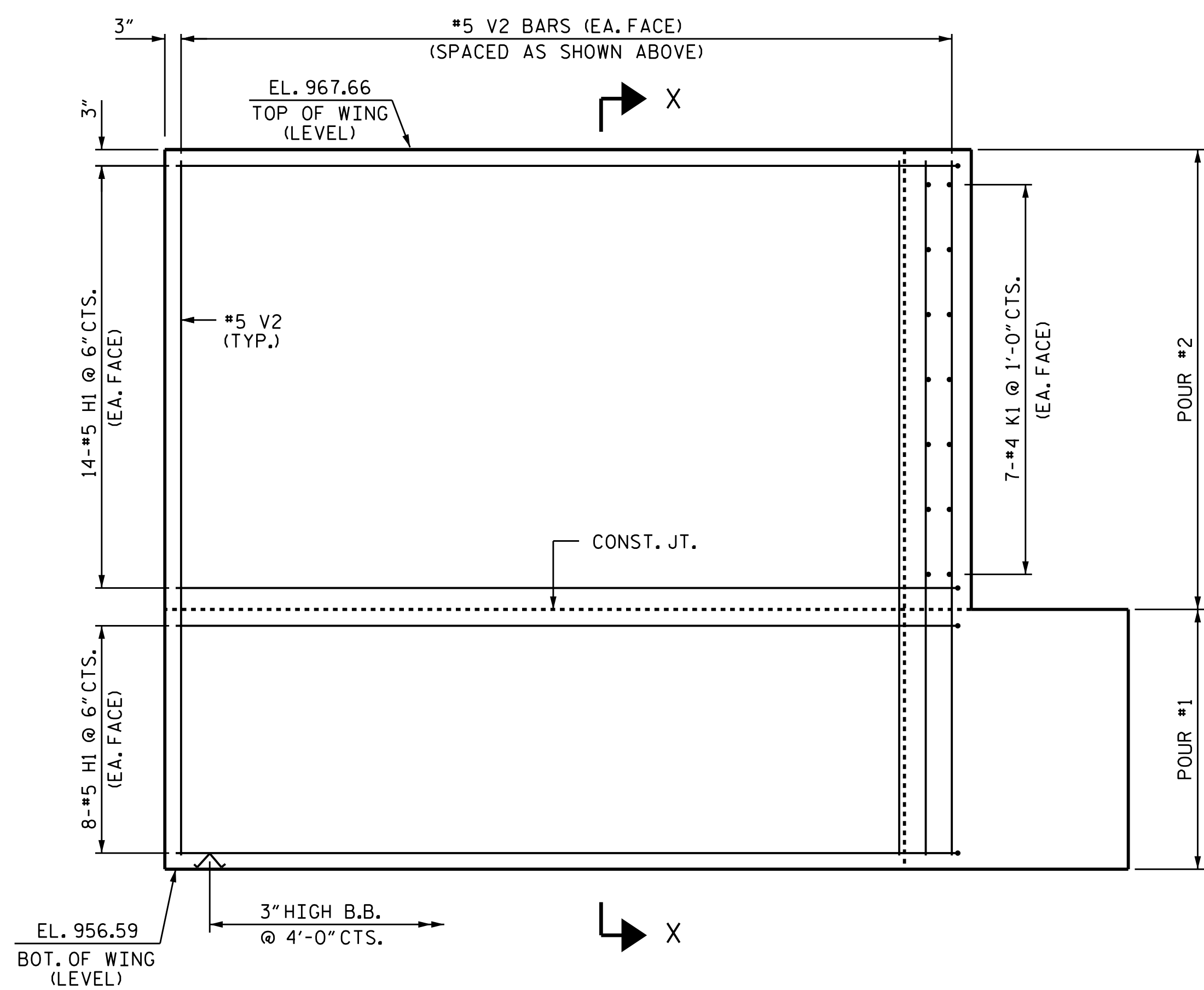

ELEVATION OF LEFT WING

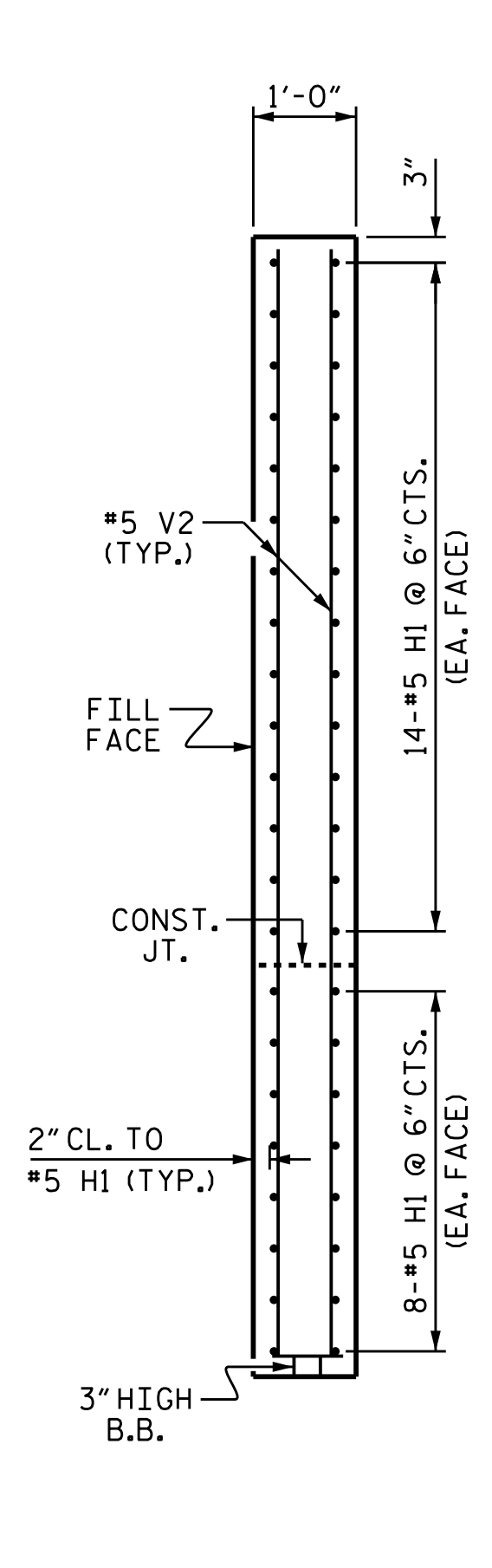

SECTION X-X

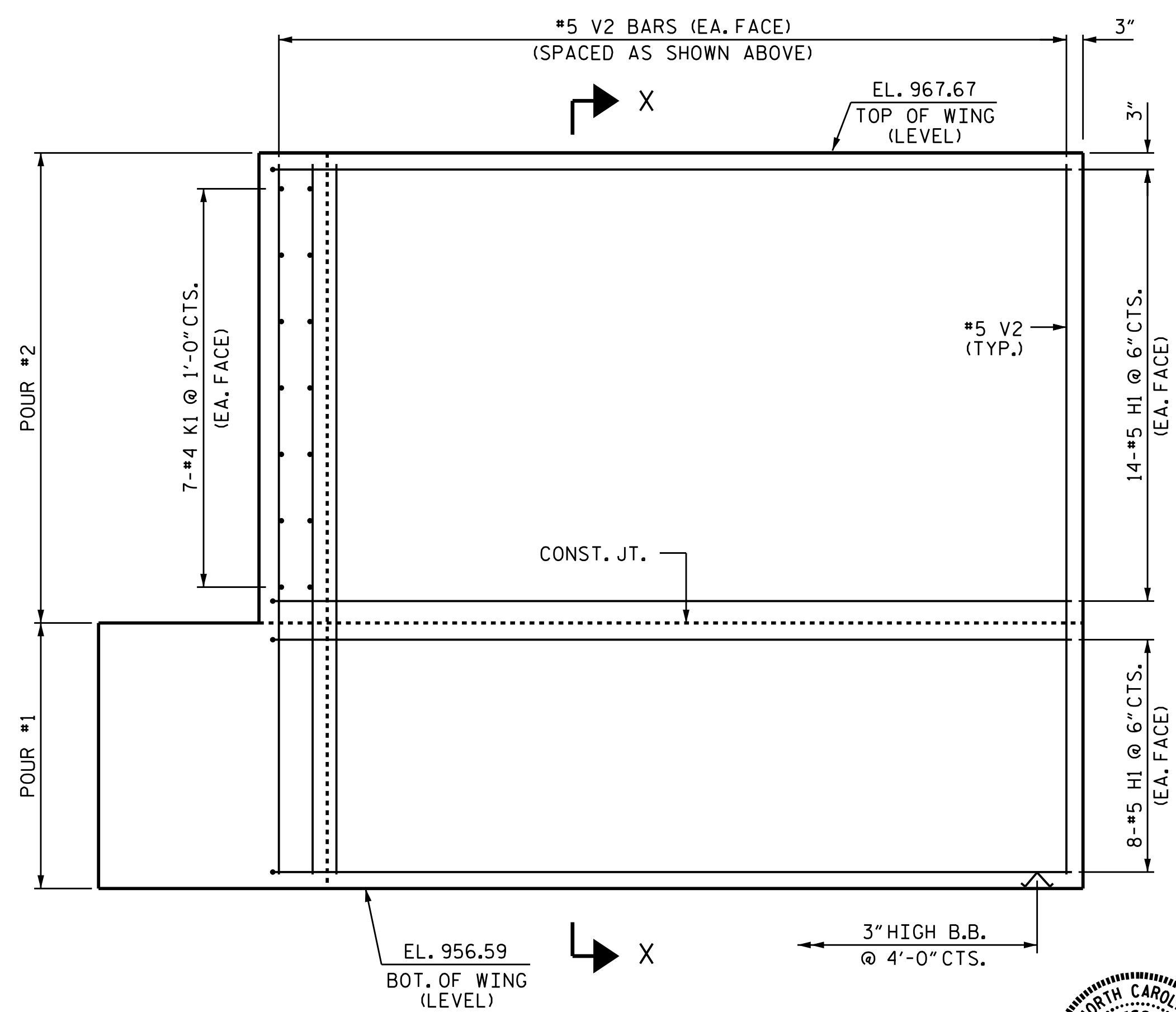

ELEVATION OF RIGHT WING

PROJECT NO. U-2579C
FORSYTH COUNTY
 STATION: 29+24.97 -Y1-

SHEET 2 OF 3

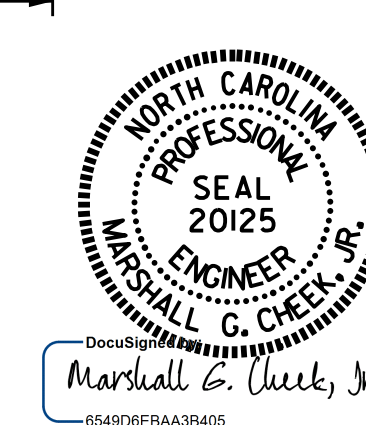

STATE OF NORTH CAROLINA
 DEPARTMENT OF TRANSPORTATION
 RALEIGH
 SUBSTRUCTURE
 INTEGRAL
 END BENT 2

DRAWN BY : N.D. AIUTO DATE : 4/6/16
 CHECKED BY : K.D. LAYNE DATE : 4/14/16
 DESIGN ENGINEER OF RECORD : H.A. LOCKLEAR DATE : 6/2017

DOCUMENT NOT CONSIDERED
 FINAL UNLESS ALL
 SIGNATURES COMPLETED

REVISIONS						SHEET NO.	
NO.	BY:	DATE:	NO.	BY:	DATE:	TOTAL SHEETS	
1			3			1	27
2			4			32	

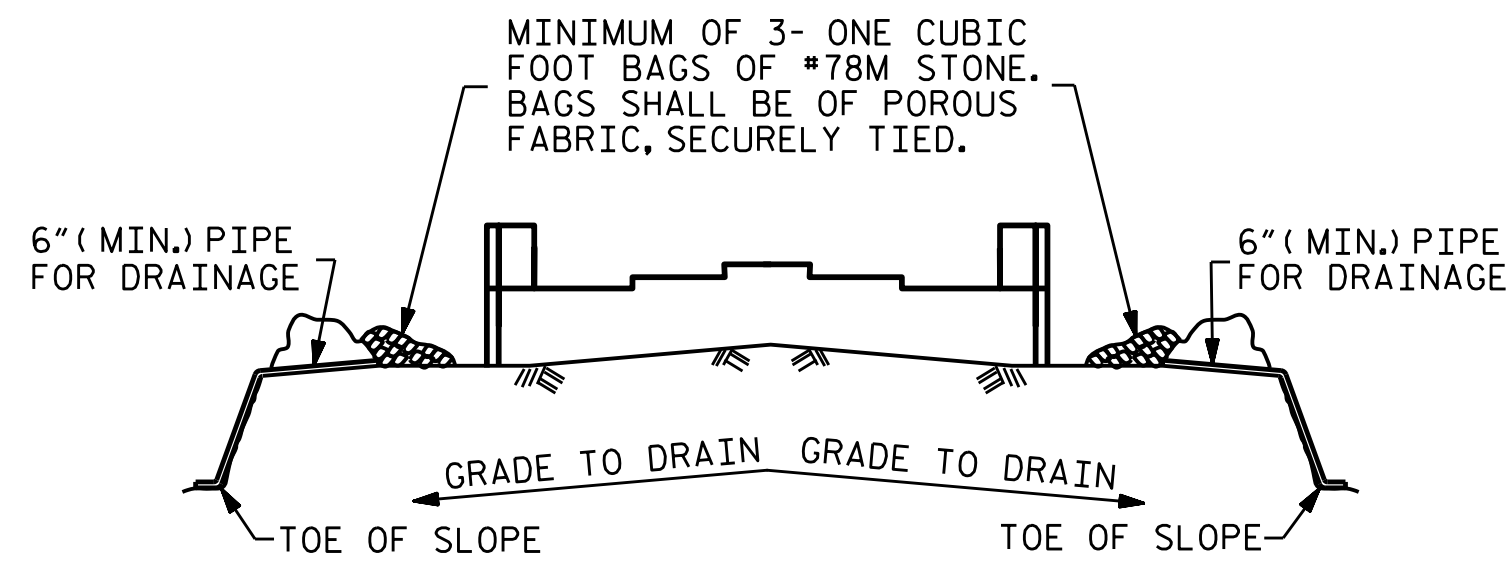

BAGGED STONE AND PIPE SHALL BE PLACED IMMEDIATELY AFTER COMPLETION OF END BENT EXCAVATION. PIPE MAY BE EITHER CONCRETE, CORRUGATED STEEL, CORRUGATED ALUMINUM ALLOY, OR CORRUGATED PLASTIC. PERFORATED PIPE WILL NOT BE ALLOWED.

BAGGED STONE SHALL REMAIN IN PLACE UNTIL THE ENGINEER DIRECTS THAT IT BE REMOVED. THE CONTRACTOR SHALL REMOVE AND DISPOSE OF SILT ACCUMULATIONS AT BAGGED STONE WHEN SO DIRECTED BY THE ENGINEER. BAGS SHALL BE REMOVED AND REPLACED WHENEVER THE ENGINEER DETERMINES THAT THEY HAVE DETERIORATED AND LOST THEIR EFFECTIVENESS.

NO SEPARATE PAYMENT WILL BE MADE FOR THIS WORK AND THE ENTIRE COST OF THIS WORK SHALL BE INCLUDED IN THE UNIT CONTRACT PRICE BID FOR THE SEVERAL PAY ITEMS.

TEMPORARY DRAINAGE AT END BENT

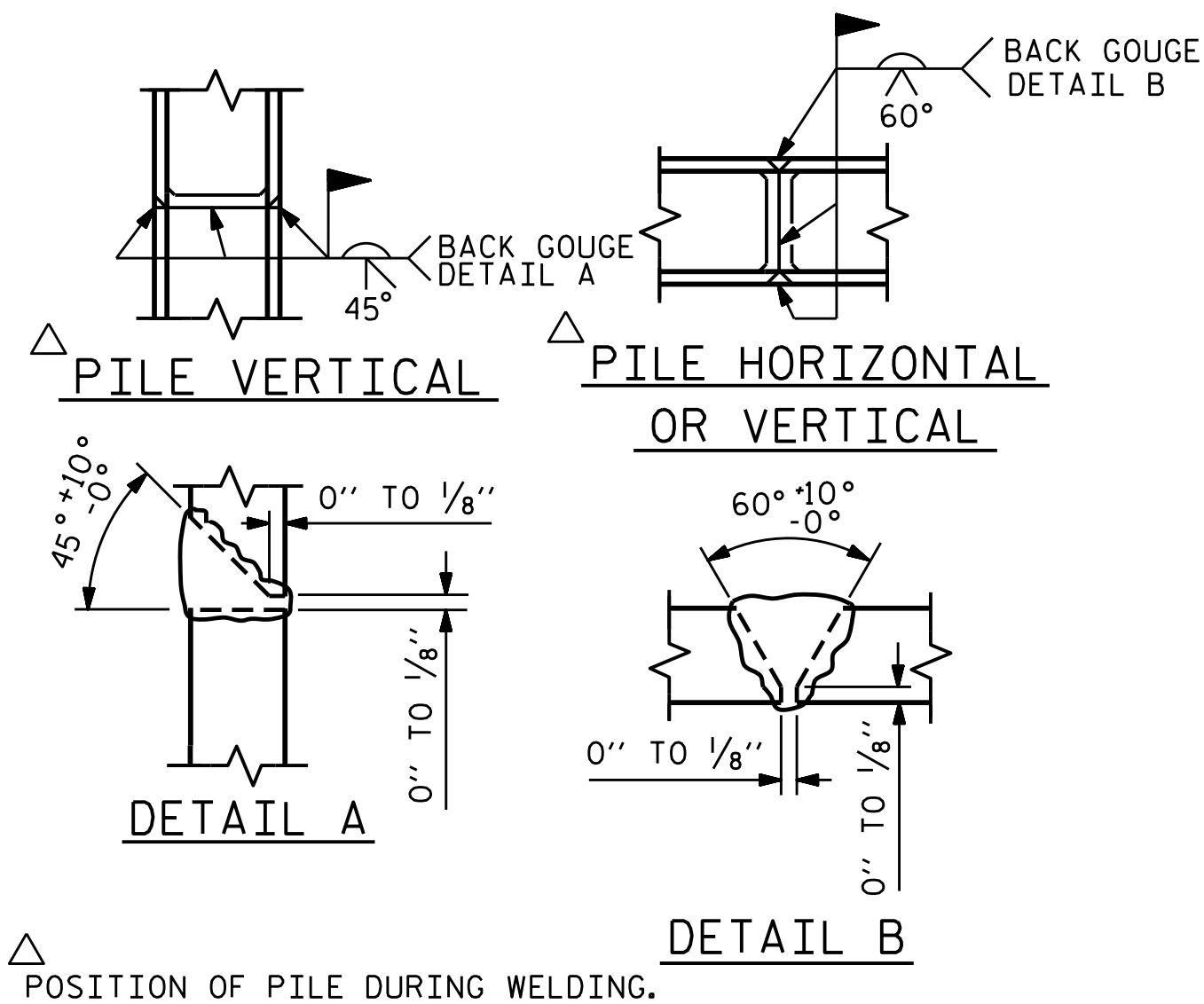

PILE SPLICE DETAILS

BAR TYPES

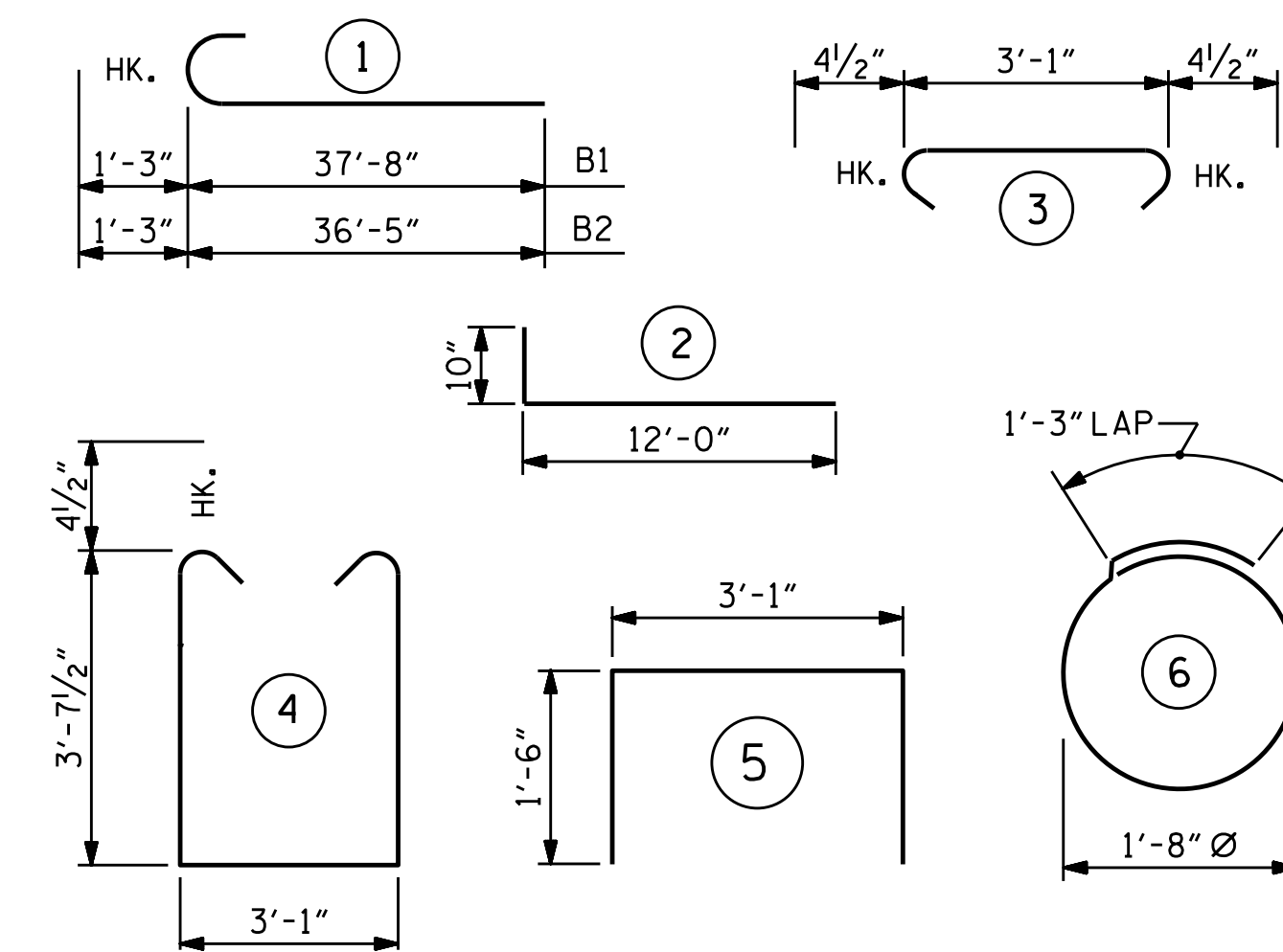

ALL BAR DIMENSIONS ARE OUT TO OUT.

BILL OF MATERIAL

END BENT 2					
BAR NO.	SIZE	TYPE	LENGTH	WEIGHT	
B1	#8	#9	1	38'-11"	1059
B2	#8	#9	1	37'-8"	1025
B3	30	#4	STR	23'-10"	478
B4	17	#4	STR	3'-1"	35
B5	4	#4	STR	13'-8"	37
H1	88	#5	2	12'-10"	1178
K1	28	#4	STR	3'-6"	65
S1	86	#4	4	11'-1"	637
S2	86	#4	3	3'-10"	220
S3	33	#4	6	6'-6"	143
U1	10	#4	5	6'-1"	41
V1	88	#4	STR	6'-0"	353
V2	68	#5	STR	10'-9"	762
REINFORCING STEEL				LBS.	6,033
CLASS A CONCRETE					
POUR #1 CAP, LOWER PART OF WINGS, & COLLARS				C.Y.	40.4
POUR #2 UPPER PART OF WINGS				C.Y.	8.0
TOTAL				C.Y.	48.4
HP 12 X 53 STEEL PILES					
NO.: 11				LIN. FT.	415
PILE DRIVING EQUIPMENT SETUP FOR HP 12 X 53 STEEL PILES					
				EACH	11

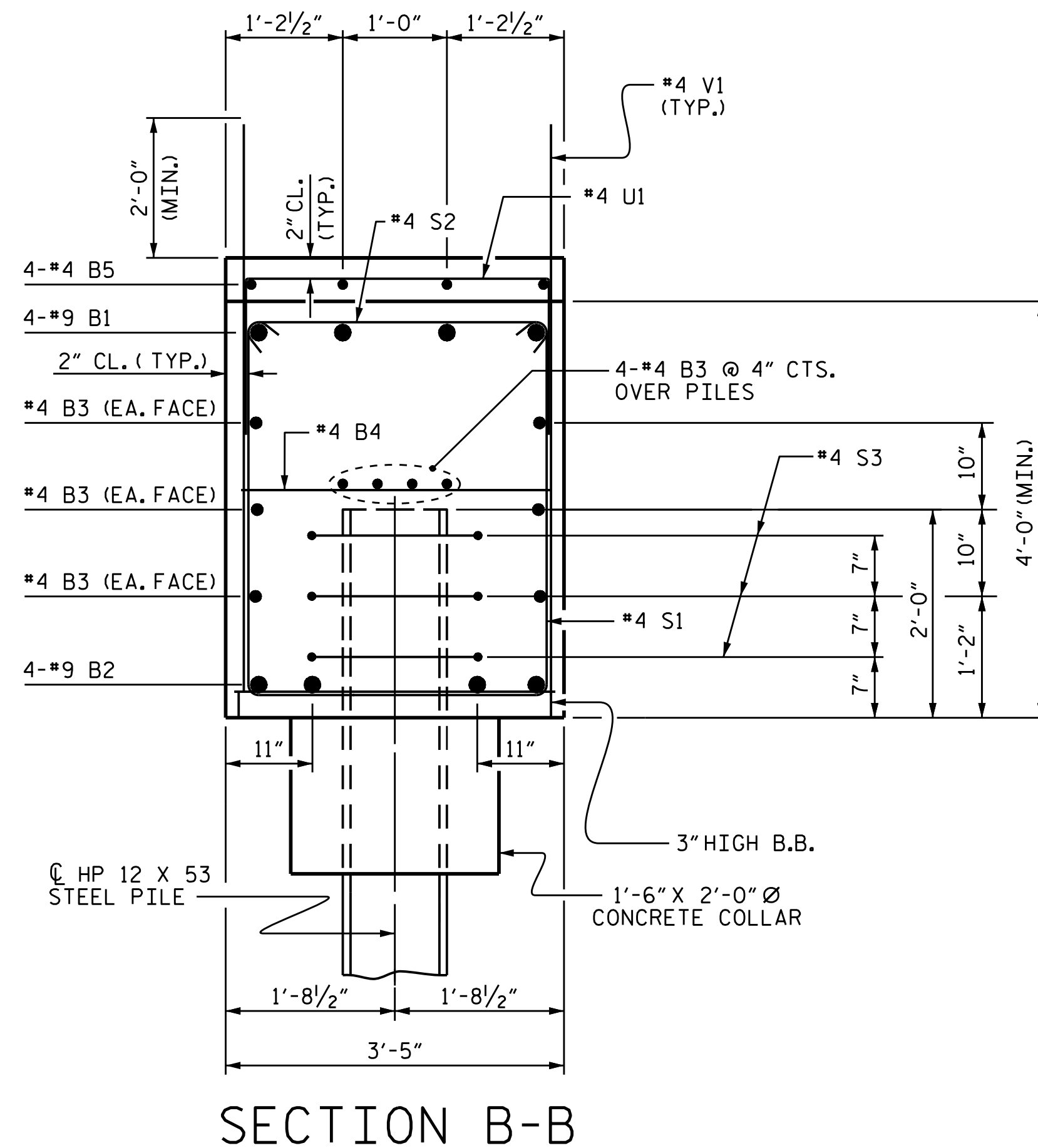
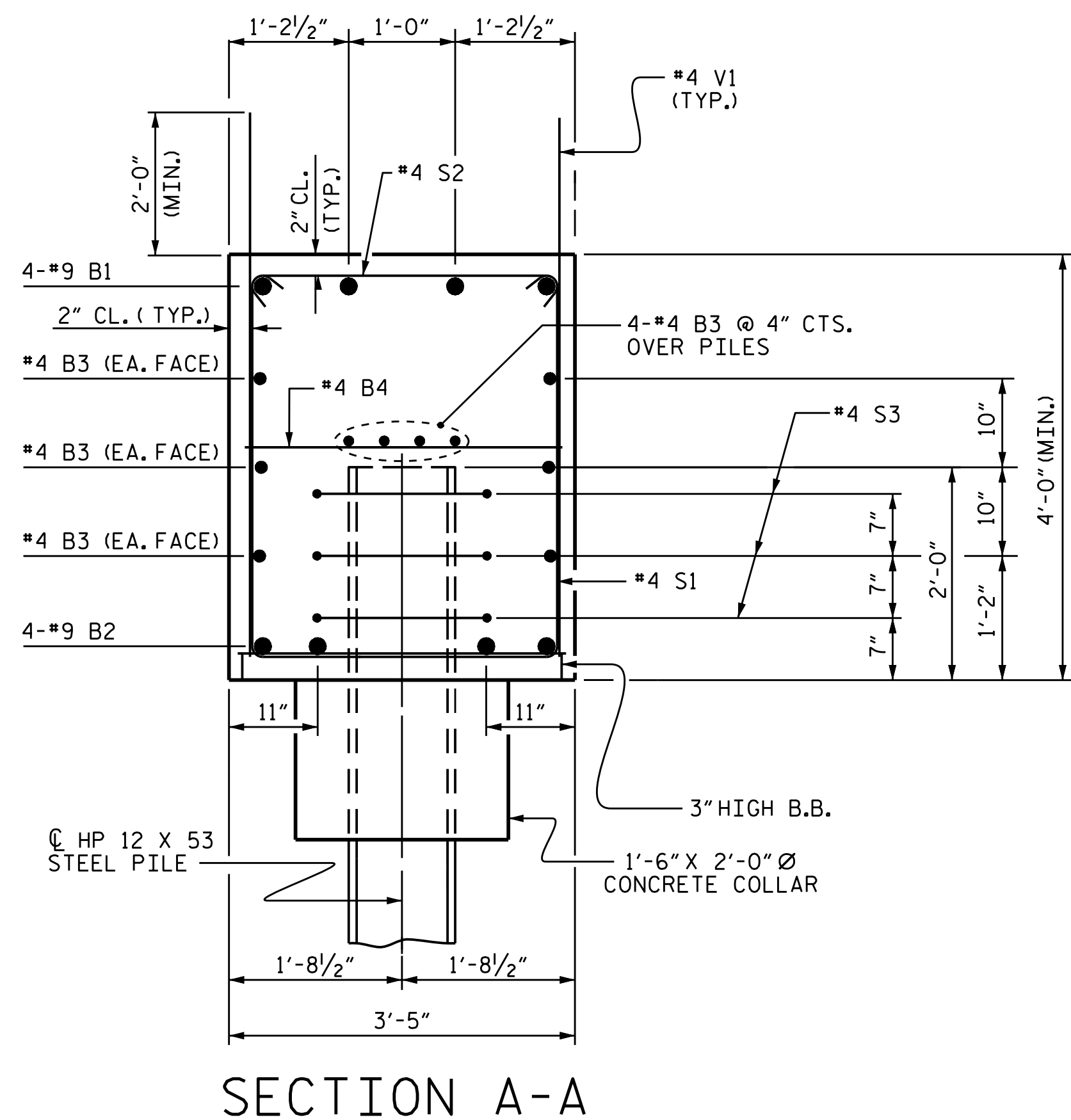

PROJECT NO. U-2579C
 FORSYTH COUNTY
 STATION: 29+24.97 -Y1-
 SHEET 3 OF 3

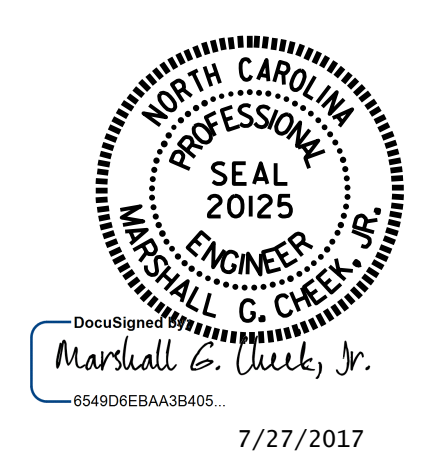

STATE OF NORTH CAROLINA
 DEPARTMENT OF TRANSPORTATION
 RALEIGH

SUBSTRUCTURE
 INTEGRAL
 END BENT 2

DRAWN BY: N.D. AIUTO DATE: 4/6/16
 CHECKED BY: K.D. LAYNE DATE: 4/14/16
 DESIGN ENGINEER OF RECORD: H.A. LOCKLEAR DATE: 6/2017

DOCUMENT NOT CONSIDERED FINAL UNLESS ALL SIGNATURES COMPLETED

REVISIONS				SHEET NO.	
NO.	BY:	DATE:	NO.	BY:	DATE:
1			3		
2			4		

S1-28
 TOTAL SHEETS
 32

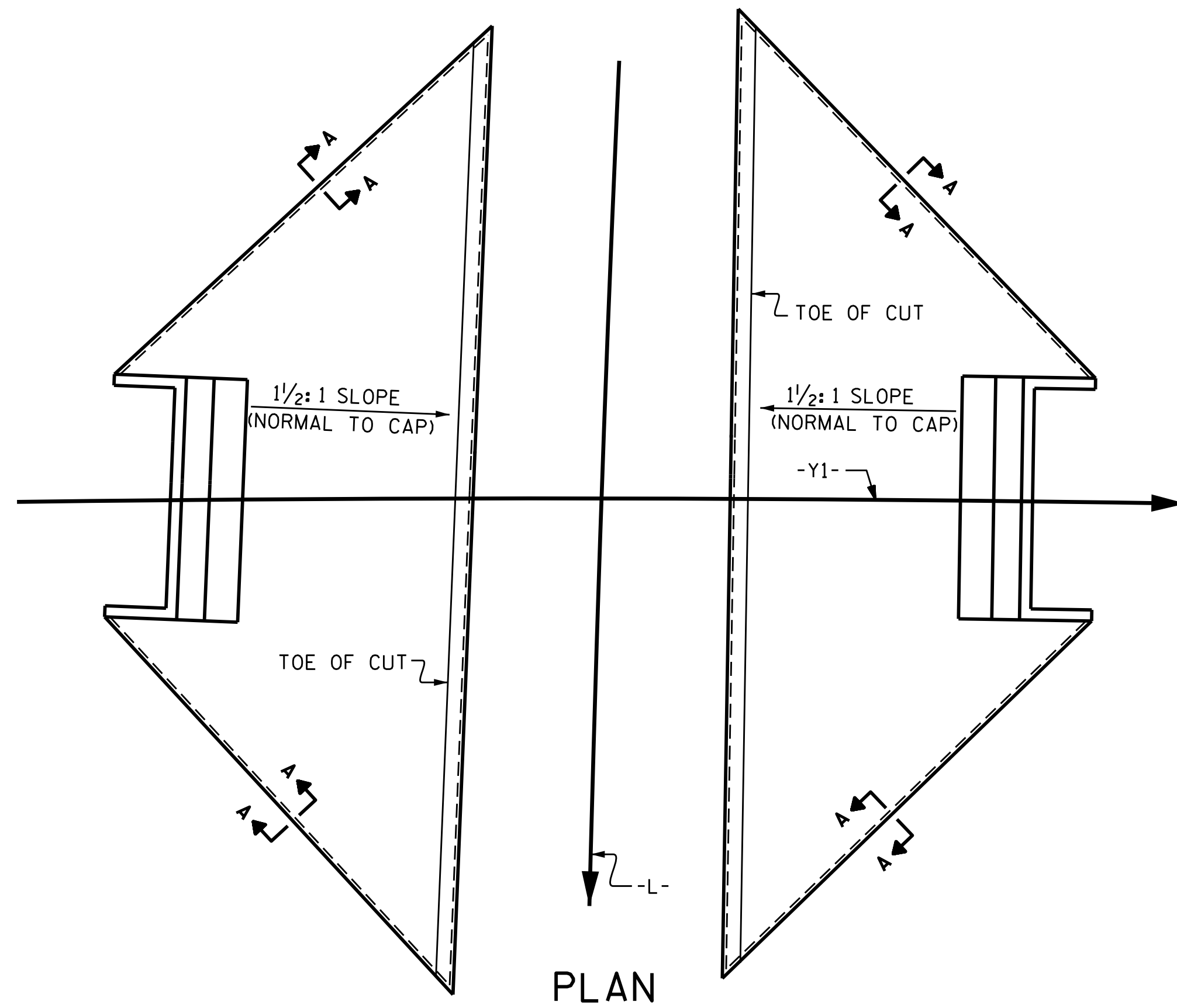

PLAN

GENERAL NOTES

STRAIGHT EDGING WILL NOT BE REQUIRED UNLESS, IN THE OPINION OF THE ENGINEER, VISUAL INSPECTION INDICATES A NEED FOR IT. MEASUREMENT AND PAYMENT SHALL BE AS PRESCRIBED IN SECTION 462 OF THE STANDARD SPECIFICATIONS. FOR BERM WIDTH, SEE GENERAL DRAWING. SLOPE PROTECTION SHALL CONSIST OF 4" POURED-IN-PLACE CONCRETE PAVING AS SHOWN IN THE DETAILS ON THIS SHEET. CONCRETE SHALL BE CLASS "B". THE CONCRETE SURFACE SHALL BE FLOATED WITH A WOODEN FLOAT AND FINISHED. WELDED WIRE FABRIC REINFORCING SHALL BE 6 X 6 - W1.4 X W1.4, 60" WIDE. SLOPE PROTECTION SHALL BE POURED IN 5' STRIPS AS SHOWN IN THE "POURING DETAIL" WITH 2'-0" LONG #4 BARS PLACED ALONG THE SLOPE BETWEEN STRIPS AT 1'-6" MAXIMUM SPACING. SLOPE PROTECTION MAY BE POURED IN ALTERNATE 4' AND 5' STRIPS AS SHOWN IN THE "OPTIONAL POURING DETAIL" WITH ADJACENT RUNS OF WELDED WIRE FABRIC LAPPING AT LEAST 6". THE COST OF THE WELDED WIRE FABRIC AND #4 BARS, IF USED, SHALL BE INCLUDED IN THE CONTRACT UNIT PRICE BID PER SQUARE YARD FOR 4" SLOPE PROTECTION.

BRIDGE @ STA. 29+24.97 -Y1-	4 INCH SLOPE PROTECTION	* WELDED WIRE FABRIC 60 INCHES WIDE
	SQUARE YARDS	APPROX. L.F.
END BENT 1	440	793
END BENT 2	386	695
TOTAL	826	1488

* QUANTITY SHOWN IS BASED ON 5' POURS.

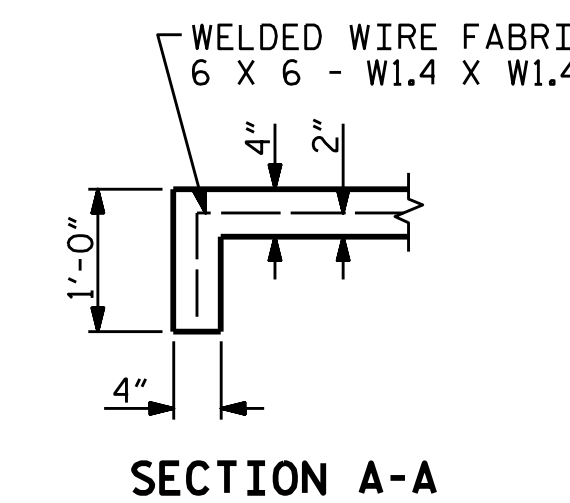

SECTION A-A

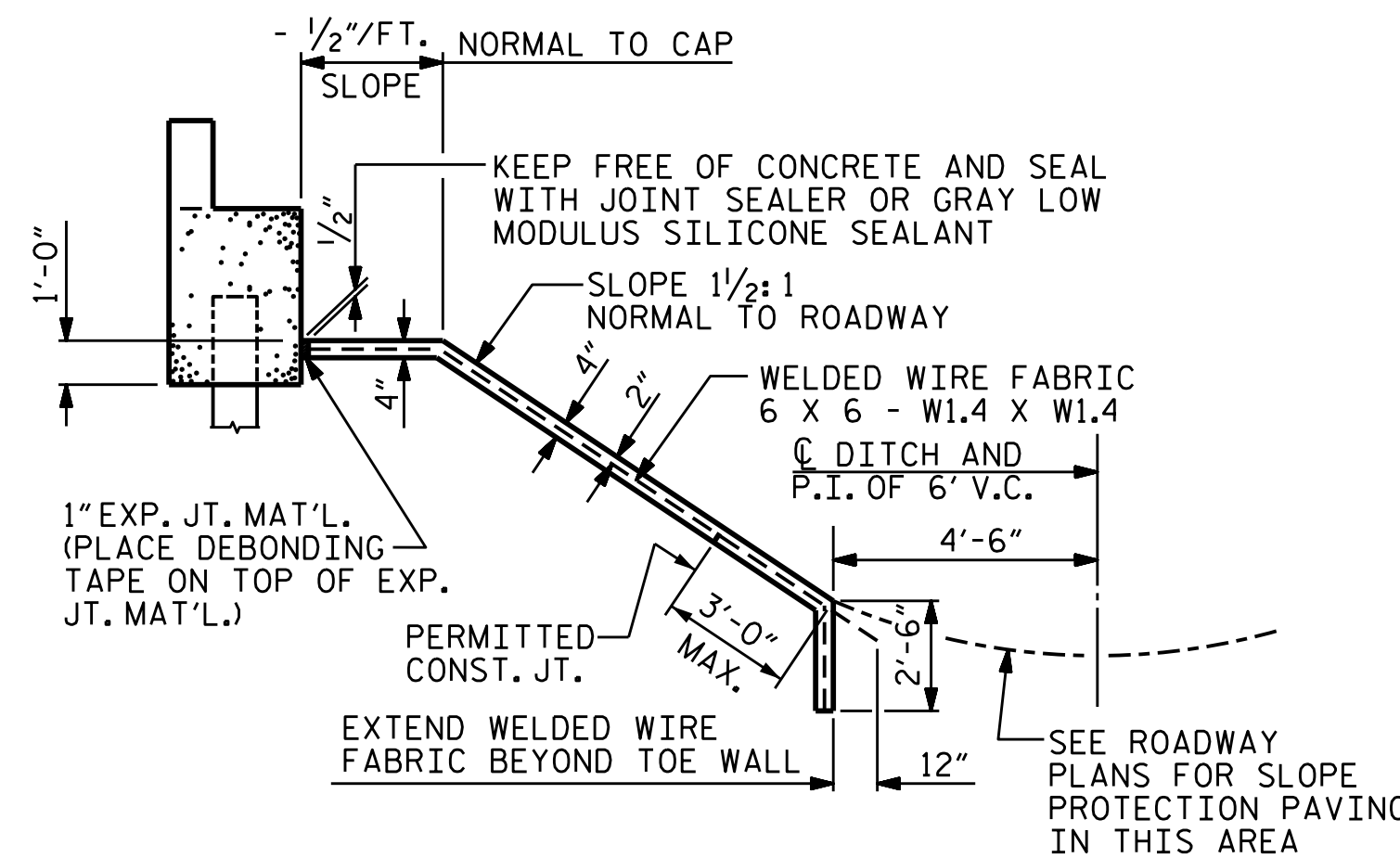

SECTION ALONG \bar{C} SURVEY WHEN SLOPE CATCHES IN DITCH

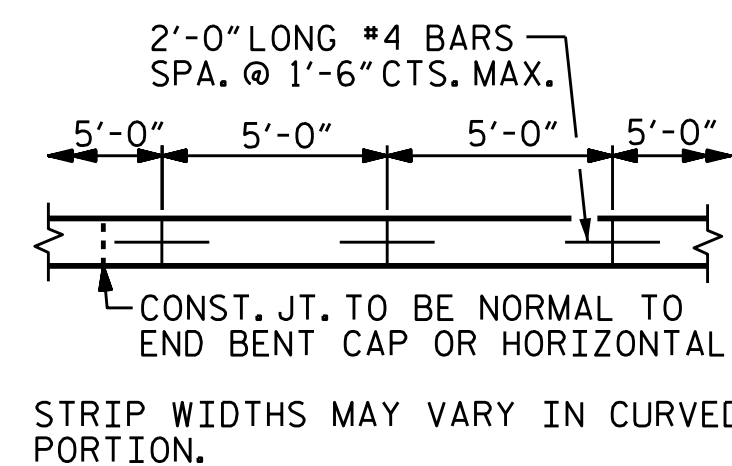

POURING DETAIL

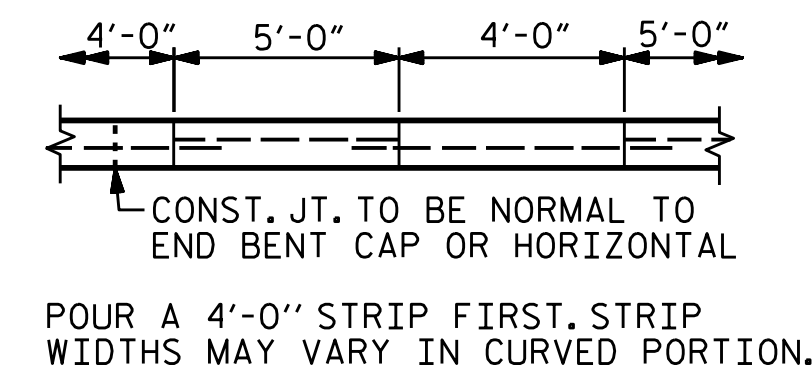

OPTIONAL POURING DETAIL

PROJECT NO. U-2579C
FORSYTH COUNTY
 STATION: 29+24.97 -Y1-

SHEET 1 OF 2

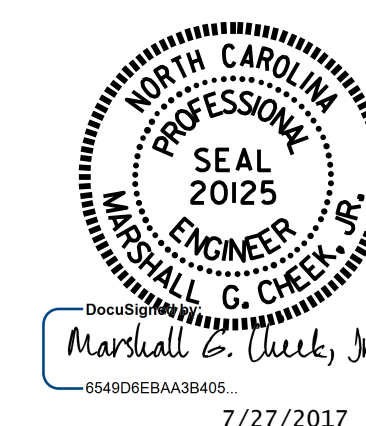

STATE OF NORTH CAROLINA
 DEPARTMENT OF TRANSPORTATION
 RALEIGH
 STANDARD
 SLOPE PROTECTION
 DETAILS

ASSEMBLED BY : H. T. BARBOUR	DATE : 1-23-17
CHECKED BY : T. L. AVERETTE	DATE : 2-21-17
DRAWN BY : ELR 5/92	REV. 10/1/11
CHECKED BY : GRP 6/92	REV. 12/21/11
	REV. 1/16
	MAA/GM
	MAA/GM
	MAA/TMG

DOCUMENT NOT CONSIDERED
 FINAL UNLESS ALL
 SIGNATURES COMPLETED

REVISIONS						SHEET NO.
NO.	BY:	DATE:	NO.	BY:	DATE:	S1-29
1			3			TOTAL SHEETS 32
2			4			

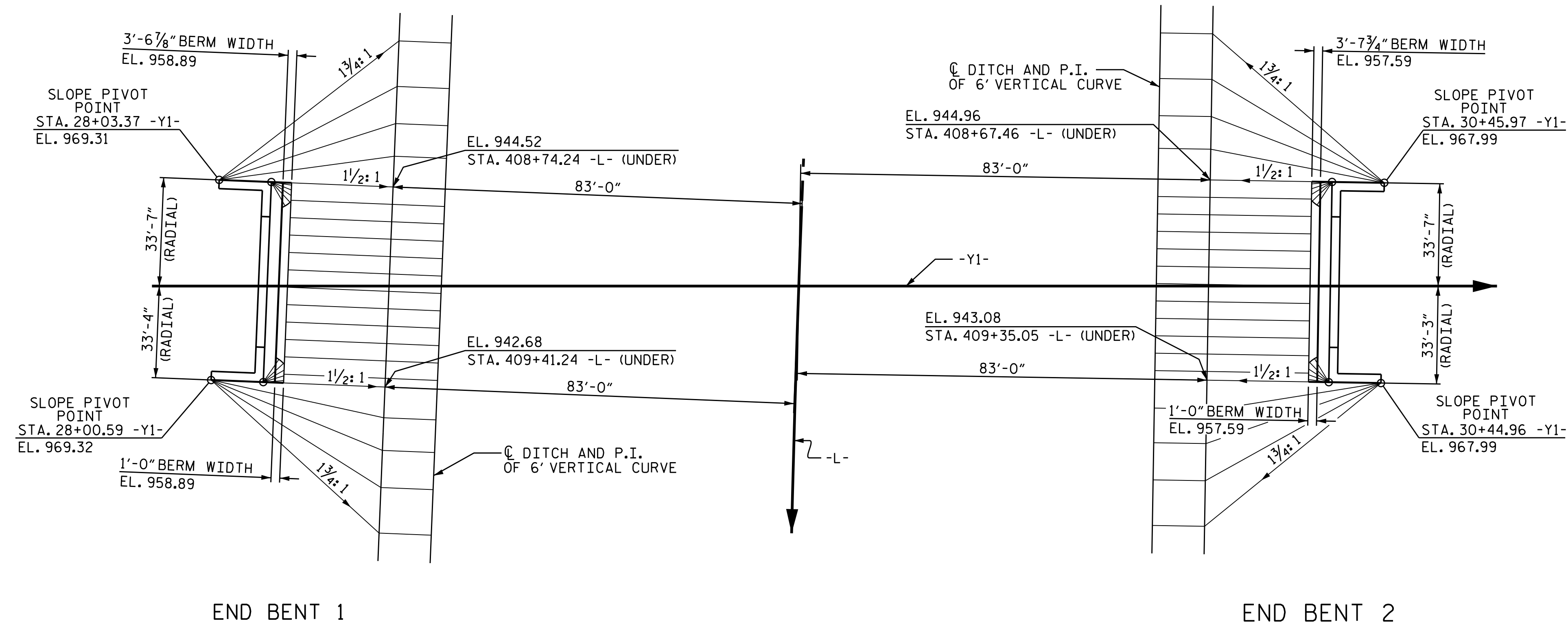

PLAN - GRADING

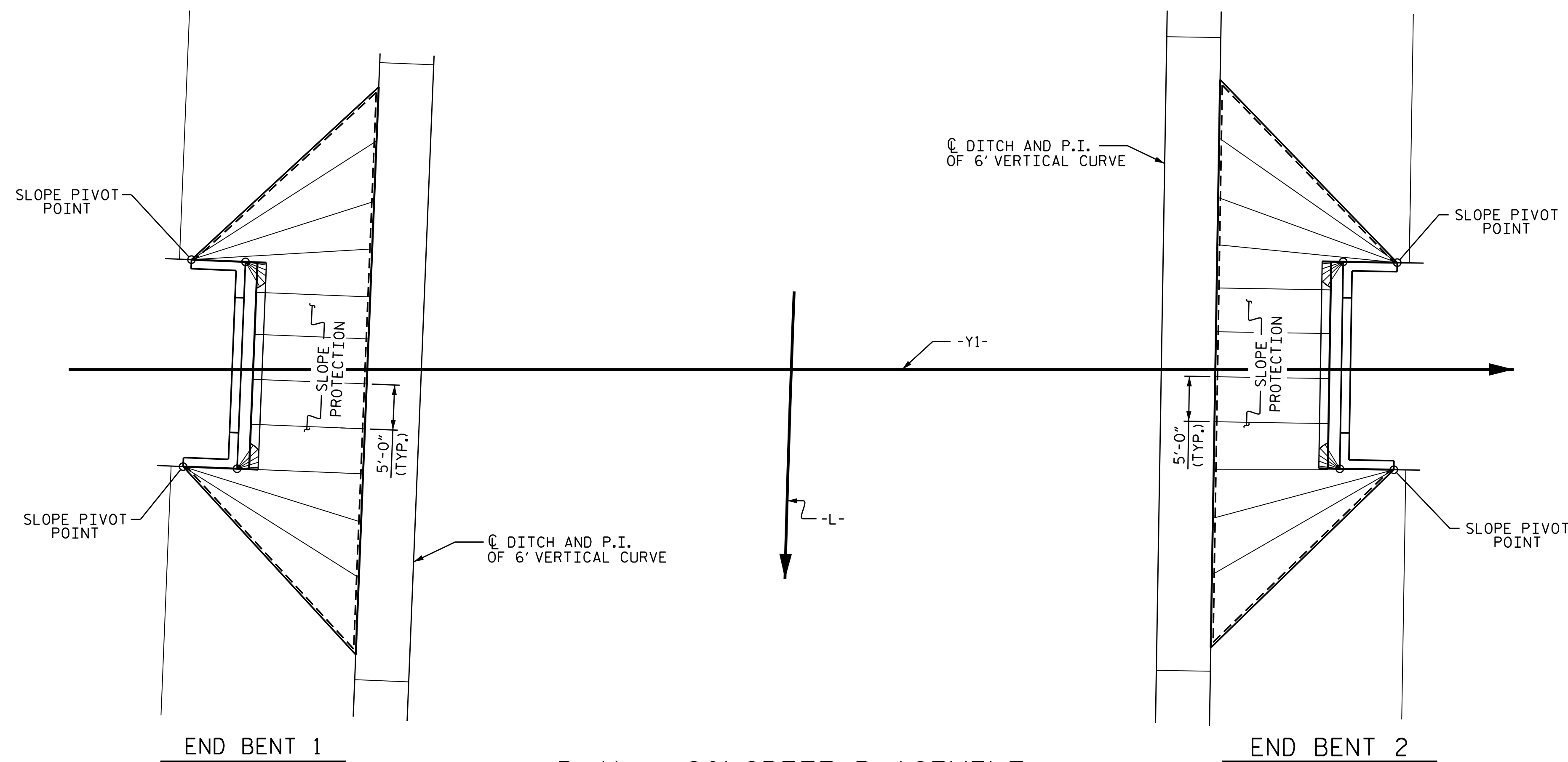

PLAN - CONCRETE PLACEMENT

PROJECT NO. U-2579C
FORSYTH COUNTY
 STATION: 29+24.97 -Y1-
 SHEET 2 OF 2



STATE OF NORTH CAROLINA
 DEPARTMENT OF TRANSPORTATION
 RALEIGH
 STANDARD
 SLOPE PROTECTION
 DETAILS

ASSEMBLED BY : H. T. BARBOUR	DATE : 1-23-17
CHECKED BY : T. L. AVERETTE	DATE : 2-21-17
DRAWN BY : WJH 10/88	REV. 5/1/06 TLA/GM
CHECKED BY : FCJ 10/88	REV. 10/1/11 MAA/GM
	REV. 1/16 MAA/TMG

DOCUMENT NOT CONSIDERED
 FINAL UNLESS ALL
 SIGNATURES COMPLETED

REVISIONS						SHEET NO.
NO.	BY:	DATE:	NO.	BY:	DATE:	S1-30
1			3			TOTAL SHEETS
2			4			32

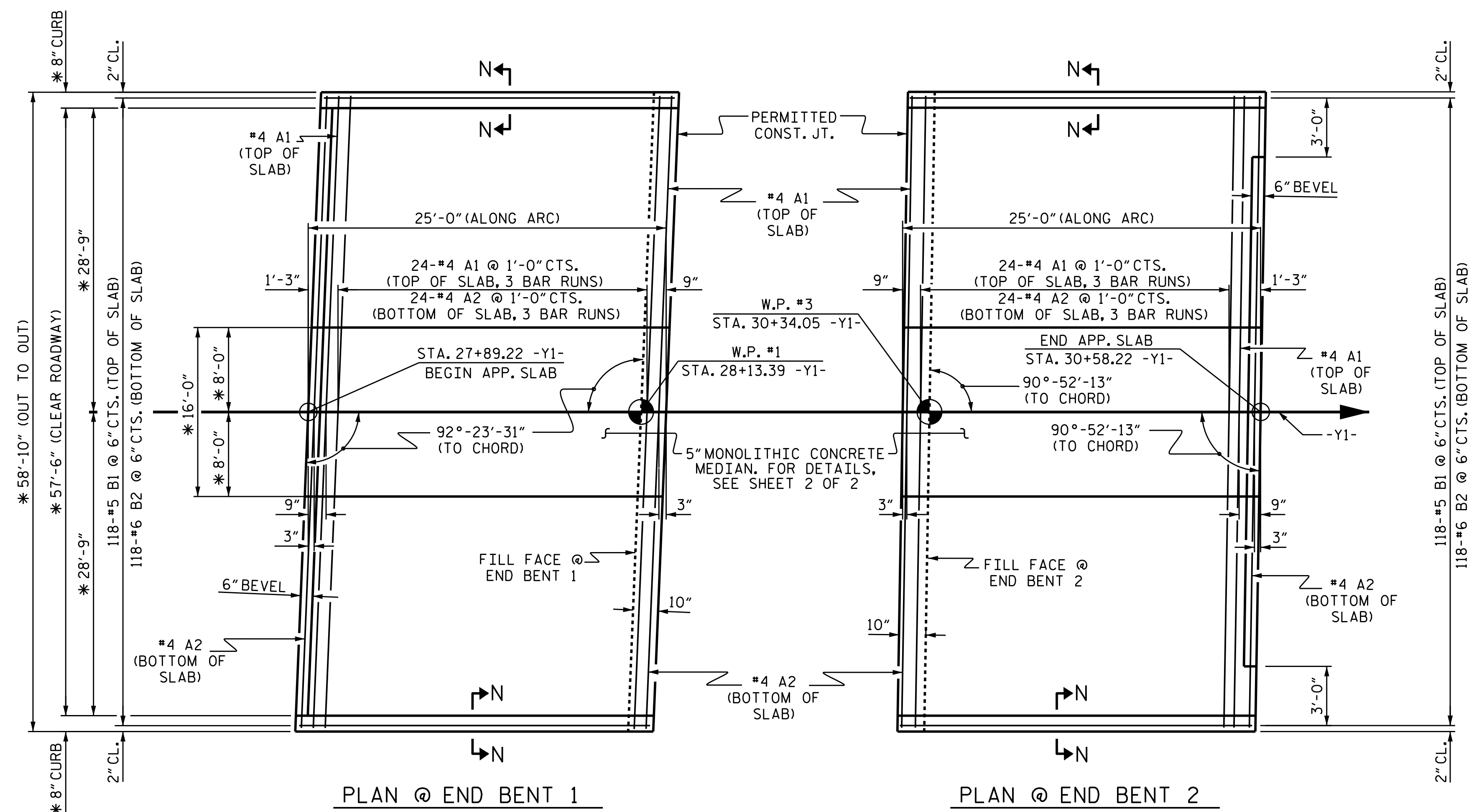

PLAN @ END BENT 1
 PLAN @ END BENT 2
 DIMENSIONS SHOWN ARE TYPICAL FOR BOTH APPROACH SLABS

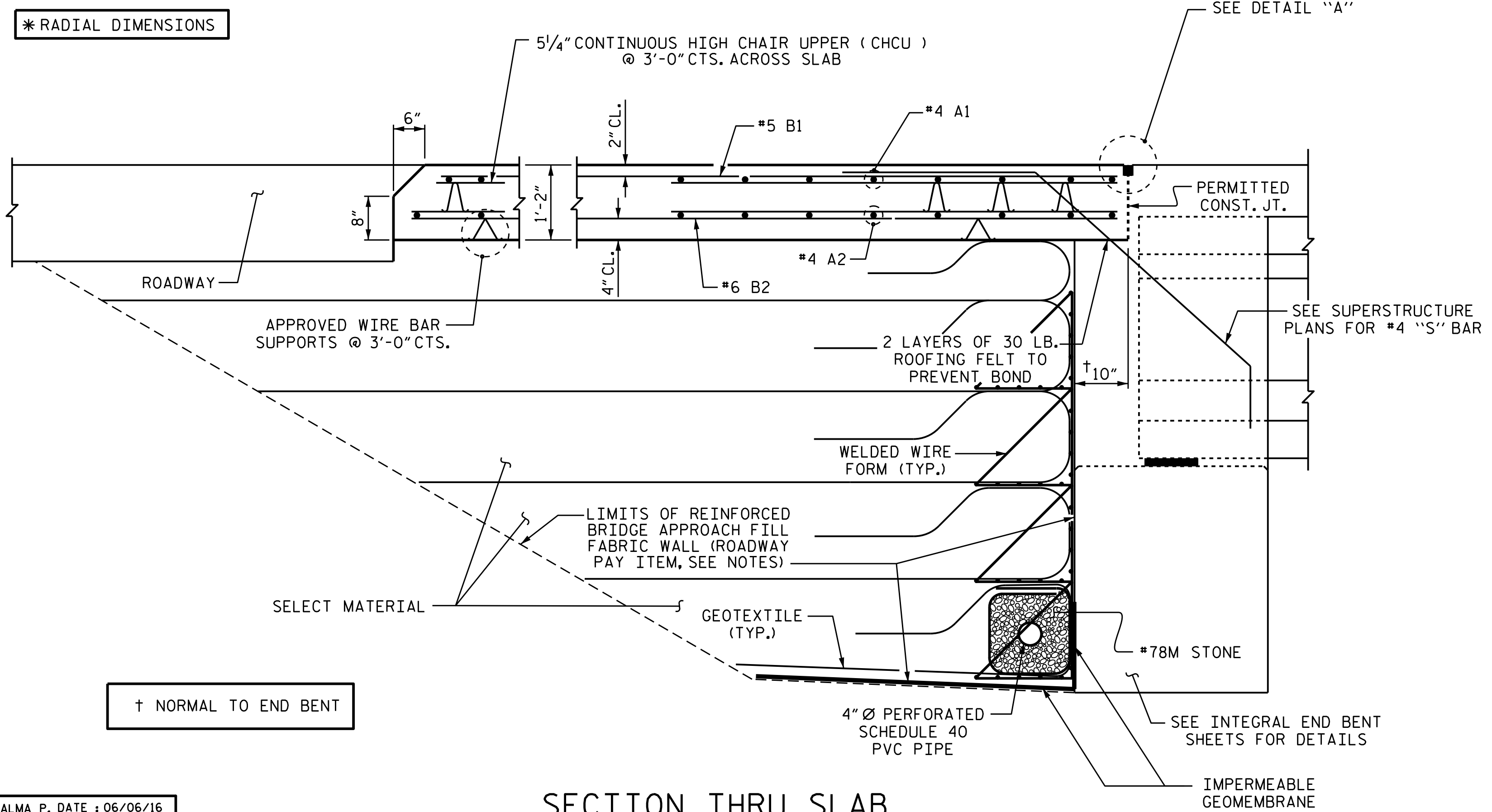

SECTION THRU SLAB

NOTES

FOR REINFORCED BRIDGE APPROACH FILL FABRIC WALL INCLUDING GEOTEXTILE, IMPERMEABLE GEOMEMBRANE, 4" Ø DRAINAGE PIPE, #78M STONE, WELDED WIRE FORM, AND SELECT MATERIAL, SEE ROADWAY PLANS.

AREA BETWEEN THE WINGWALL AND APPROACH SLAB SHALL BE GRADED TO DRAIN THE WATER AWAY FROM THE FILL FACE OF THE BRIDGE AND SHALL BE PAVED. SEE ROADWAY PLANS.

THE JOINT OPENING AT THE APPROACH SLAB/DECK INTERFACE SHALL BE SAWED NO MORE THAN 12 HOURS AFTER THE APPROACH SLAB IS CAST. THE JOINT SHALL BE CLEANED OF ALL DEBRIS BEFORE THE SEALANT IS APPLIED. THE JOINT SEALER MATERIAL SHALL CONFORM TO THE REQUIREMENTS OF SECTION 1028-3 OF THE STANDARD SPECIFICATIONS.

ARC OFFSETS ARE NEGLIGIBLE AND THEREFORE NOT SHOWN.

GROOVED CONTRACTION JOINTS, 1/2" IN DEPTH, SHALL BE TOOLED IN ALL EXPOSED FACES OF THE MONOLITHIC CONCRETE MEDIAN IN ACCORDANCE WITH ARTICLE 825-10(B) OF THE STANDARD SPECIFICATIONS. THE CONTRACTION JOINTS SHALL BE LOCATED AT A SPACING OF 8 FT. TO 10 FT. BETWEEN EXPANSION JOINTS. NO CONTRACTION JOINT WILL BE REQUIRED FOR SEGMENTS LESS THAN 10 FT. IN LENGTH.

ALL REINFORCING STEEL IN MONOLITHIC CONCRETE MEDIAN SHALL BE EPOXY COATED.

NO SEPARATE MEASUREMENT OR PAYMENT WILL BE MADE FOR MATERIALS OR LABOR REQUIRED TO CONSTRUCT THE CONCRETE MEDIAN ON THE APPROACH SLABS. THE ENTIRE COST OF THIS WORK SHALL BE INCLUDED IN THE LUMP SUM BID PRICE FOR BRIDGE APPROACH SLABS.

THE APPROACH SLAB MAY BE CAST MONOLITHICALLY WITH THE END BENT DIAPHRAGM AND THE END SECTION OF BRIDGE DECK NEAR THE INTEGRAL END BENT.

BILL OF MATERIAL

FOR ONE APPROACH SLAB (2 REQ'D)

BAR	NO.	SIZE	TYPE	LENGTH	WEIGHT
* A1	78	#4	STR	20'-11"	1,090
A2	78	#4	STR	20'-9"	1,081
* B1	118	#5	STR	24'-3"	2,985
B2	118	#6	STR	24'-8"	4,372
* B3	15	#4	STR	24'-0"	240
* G1	17	#4	STR	15'-6"	176
REINFORCING STEEL				LBS.	5,453
* EPOXY COATED REINFORCING STEEL				LBS.	4,491
CLASS AA CONCRETE					
POUR 1 - APPROACH SLAB				C. Y.	63.3
POUR 2 - CONCRETE MEDIAN				C. Y.	6.0
TOTAL				C. Y.	69.3

SPLICE LENGTH

BAR SIZE	EPOXY COATED	UNCOATED
#4	2'-0"	1'-9"
#5	2'-6"	2'-2"

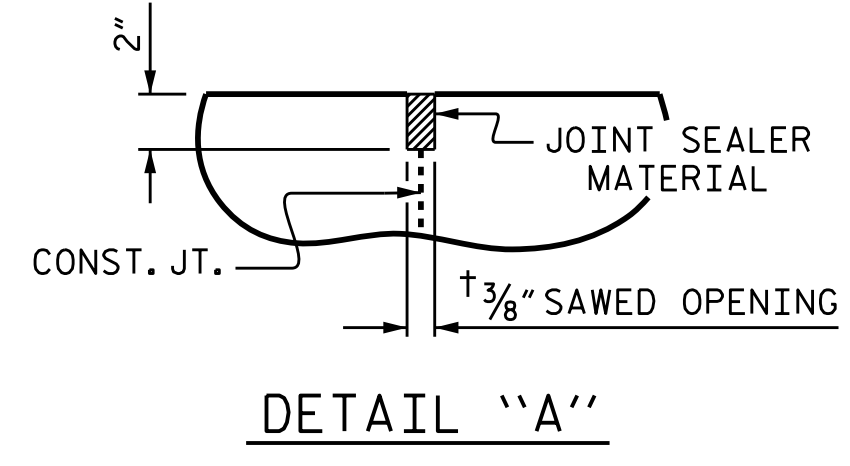
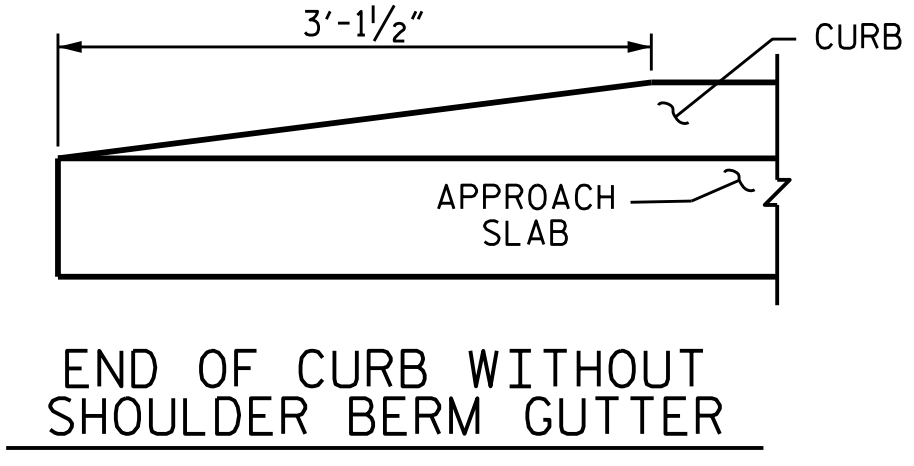
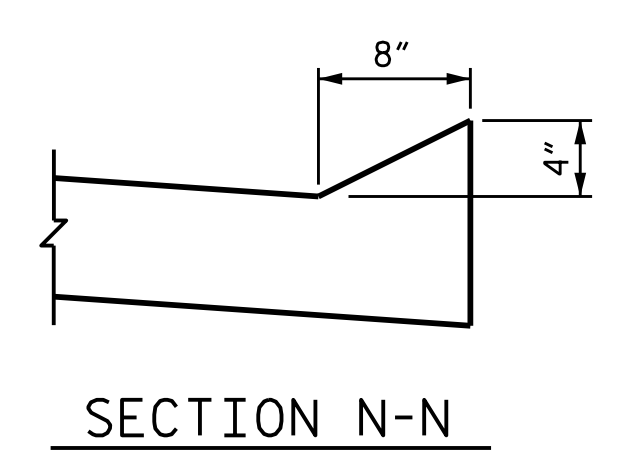

PROJECT NO. U-2579C
 FORSYTH COUNTY
 STATION: 29+24.97 -Y1-

SHEET 1 OF 2

STATE OF NORTH CAROLINA
 DEPARTMENT OF TRANSPORTATION
 RALEIGH

BRIDGE APPROACH SLAB
 FOR INTEGRAL
 ABUTMENT

65490EBAA38405
 7/27/2017

REVISIONS						SHEET NO.
NO.	BY:	DATE:	NO.	BY:	DATE:	S1-31
1			3			TOTAL SHEETS
2			4			32

ASSEMBLED BY : ARIADNE PALMA P. DATE : 06/06/16
 CHECKED BY : M.K. BEARD DATE : 7/26/16

DRAWN BY : TLA 10/05 REV. 10/1/11 MAA/GM
 CHECKED BY : GM 5/06 REV. 12/21/11 MAA/GM
 REV. 6/13 MAA/GM

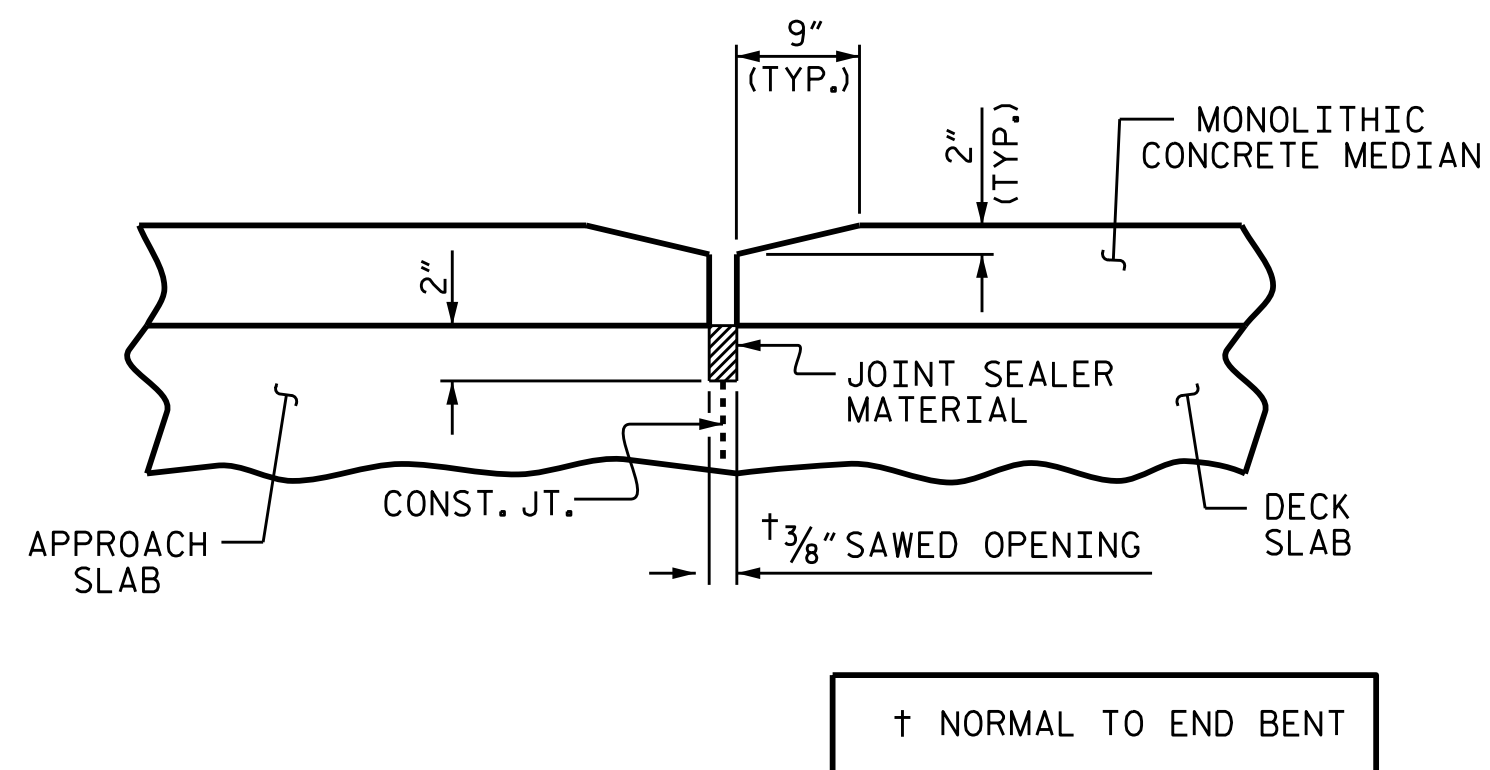

SECTION THROUGH MONOLITHIC CONCRETE MEDIAN AT INTEGRAL END BENT

END BENT 1 SHOWN, END BENT 2 SIMILAR

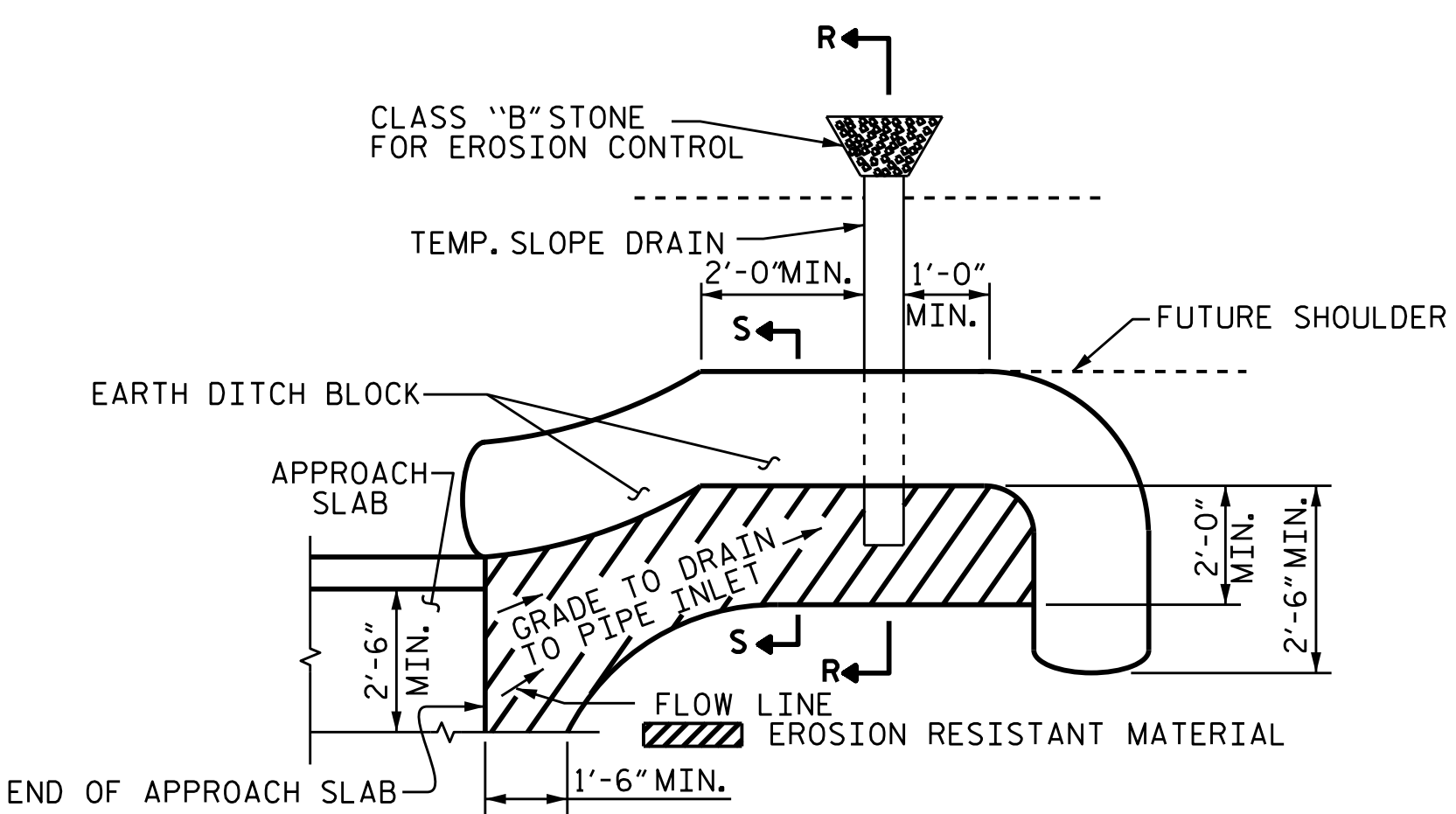

NOTE: IMMEDIATELY AFTER THE CONSTRUCTION OF THE APPROACH SLAB, THE CONTRACTOR SHALL PROVIDE TEMPORARY BERM AND SLOPE DRAIN. CONTRACTOR SHALL GRADE TO PIPE INLET AND PROVIDE EROSION RESISTANT MATERIAL AS SHOWN. THE EROSION RESISTANT MATERIAL SHALL BE EITHER 1) ASPHALT PLANT MIX, TYPE 1 OR TYPE 2, MIN. 2" DEPTH, 2) EROSION CONTROL MAT, OR 3) CONCRETE, AS DIRECTED BY THE ENGINEER. THE SLOPE DRAIN SHALL CONSIST OF A NON-PERFORATED TEMPORARY DRAINAGE PIPE, 12 INCHES IN DIAMETER.

PLAN VIEW

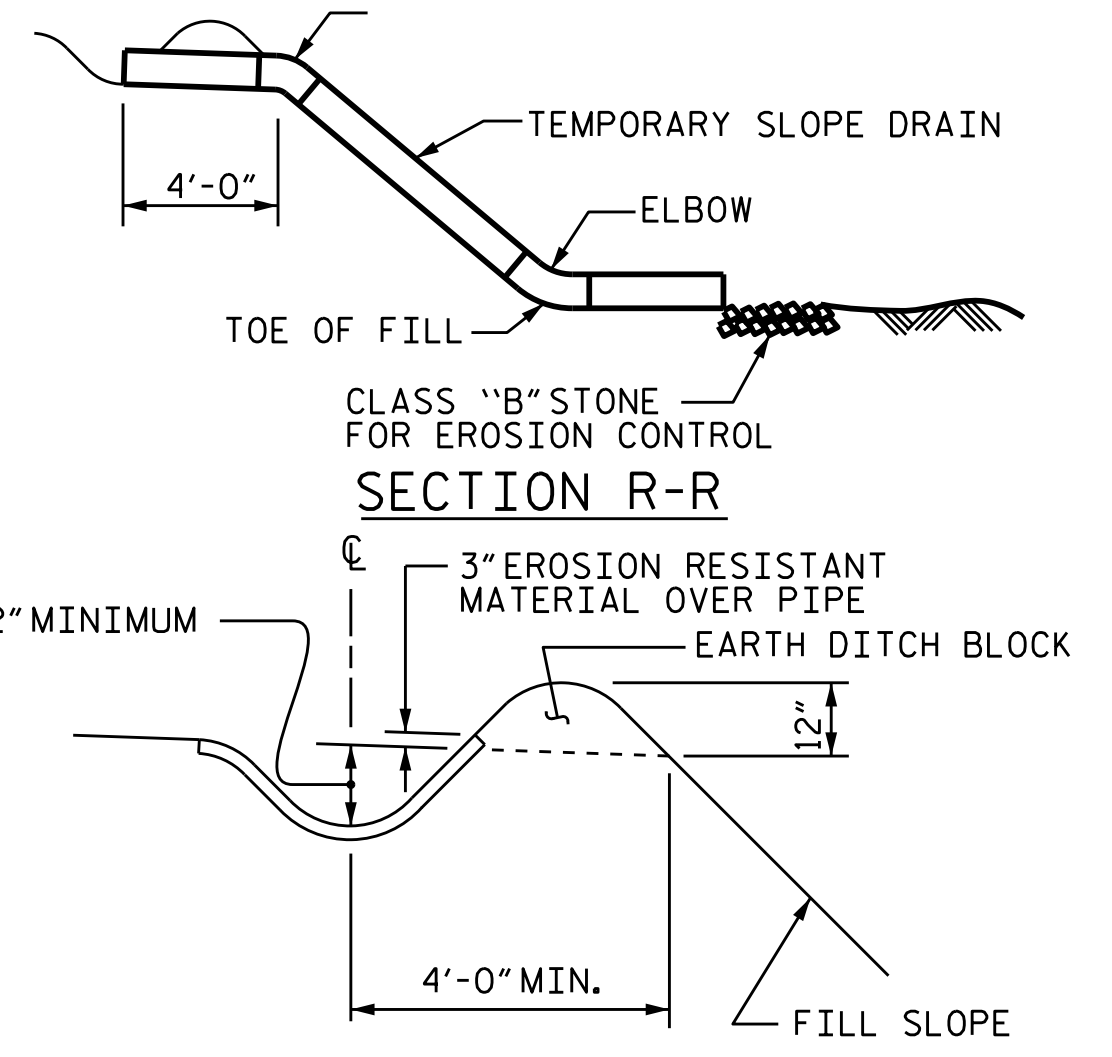

SECTION S-S

TEMPORARY BERM AND SLOPE DRAIN DETAILS

(TO BE USED WHEN SHOULDER BERM GUTTER IS REQUIRED)

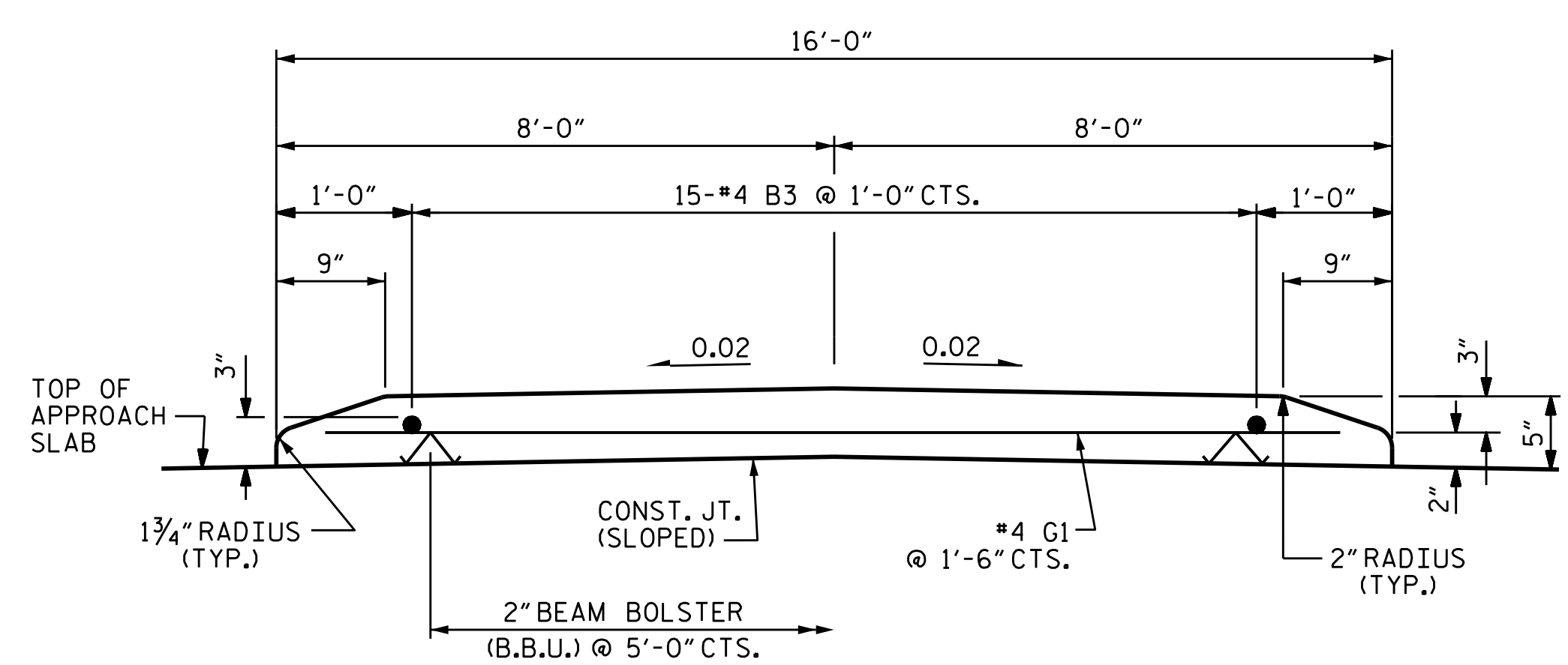

SECTION THROUGH MONOLITHIC CONCRETE MEDIAN

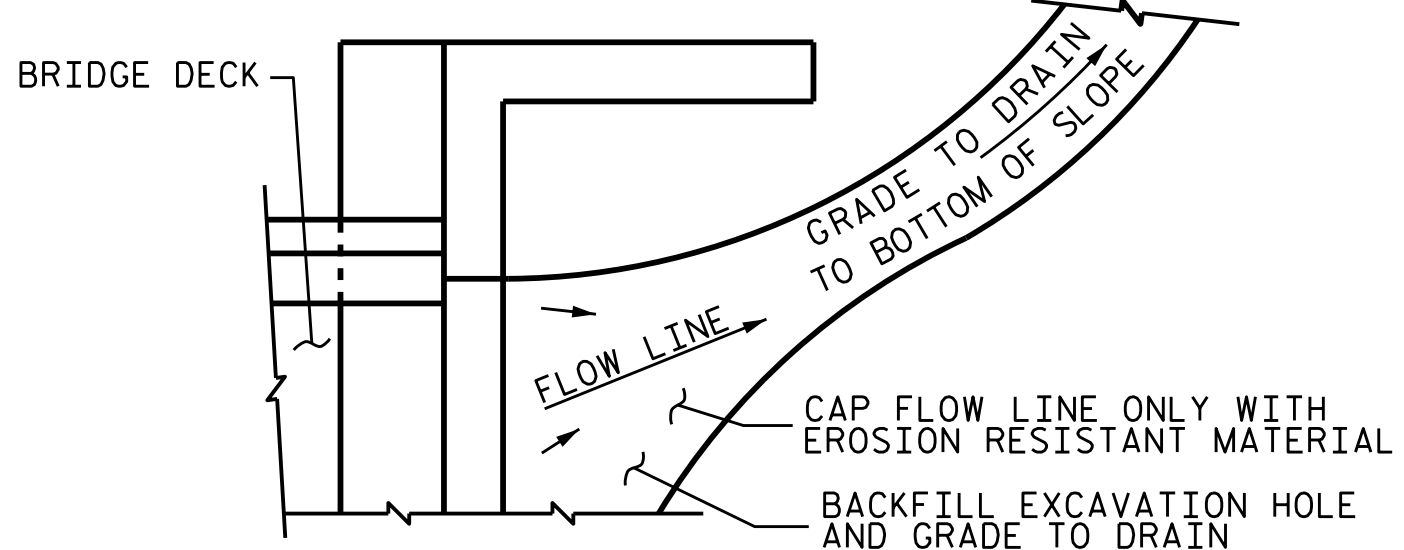

NOTE: IF THE APPROACH SLAB IS NOT CONSTRUCTED IMMEDIATELY AFTER THE BACKFILLING OF THE END BENT EXCAVATION, GRADE TO DRAIN TO THE BOTTOM OF THE SLOPE AND PROVIDE EROSION RESISTANT MATERIAL, SUCH AS FIBERGLASS ROVING OR AS DIRECTED BY THE ENGINEER TO PREVENT SOIL EROSION AND TO PROTECT THE AREA ADJACENT TO THE STRUCTURE. THE CONTRACTOR WILL BE REQUIRED TO REMOVE THESE MATERIALS PRIOR TO CONSTRUCTION OF THE APPROACH SLAB.

TEMPORARY DRAINAGE DETAIL

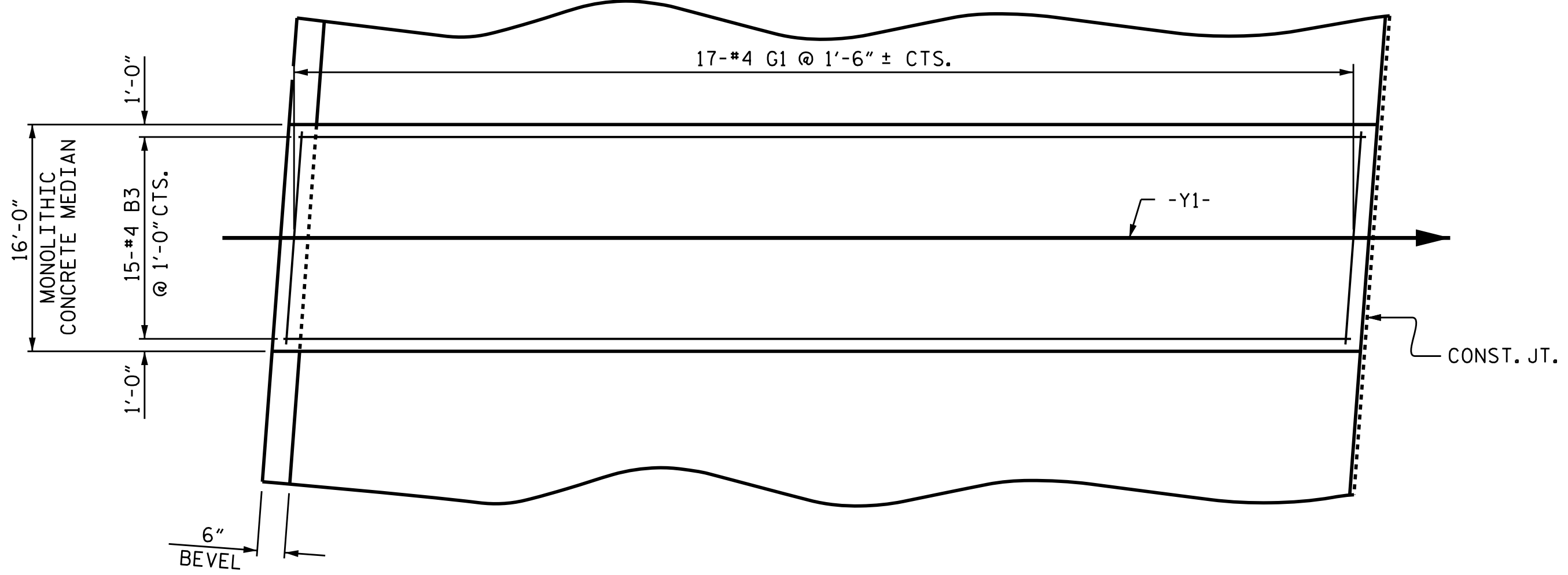

PLAN OF CONCRETE MEDIAN

APPROACH SLAB AT END BENT 1 SHOWN, APPROACH SLAB AT END BENT 2 SIMILAR.

PROJECT NO. U-2579C
 FORSYTH COUNTY
 STATION: 29+24.97 -Y1-

SHEET 2 OF 2

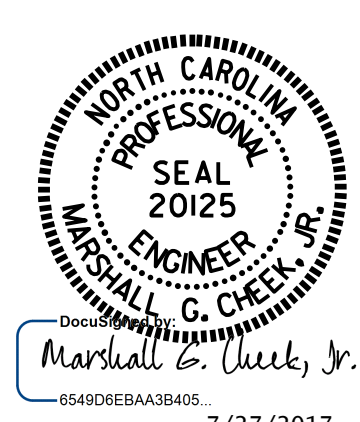

STATE OF NORTH CAROLINA
 DEPARTMENT OF TRANSPORTATION
 RALEIGH
 STANDARD
 BRIDGE APPROACH SLAB
 FOR INTEGRAL
 ABUTMENT

ASSEMBLED BY : ARIADNE PALMA P.	DATE : 06/06/16
CHECKED BY : M.K. BEARD	DATE : 7/26/16
DRAWN BY : TLA	10/05
CHECKED BY : GM	5/06
REV. 10/1/11	MAA/GM
REV. 12/21/11	MAA/GM
REV. 6/13	MAA/GM

DOCUMENT NOT CONSIDERED
 FINAL UNLESS ALL
 SIGNATURES COMPLETED

REVISIONS						SHEET NO.	
NO.	BY:	DATE:	NO.	BY:	DATE:	S1-32	
1			3			TOTAL SHEETS	
2			4			32	

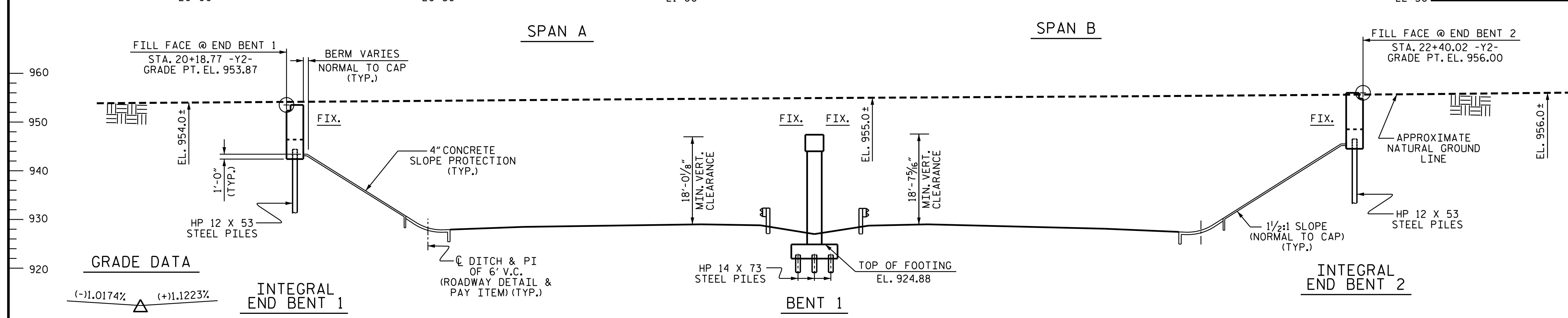

GRADE DATA

(+)1.1223% (+)1.3023%

PI STA. = 25+50.00 -Y2-
EL. = 959.48
L = 200'

GRADE DATA

(-)1.0174% (+)1.1223%

PI STA. = 16+10.00 -Y2-
EL. = 948.93
L = 1220'

SECTION ALONG -Y2-
SECTIONS AT END BENTS AND BENT ARE TAKEN AT RIGHT ANGLES

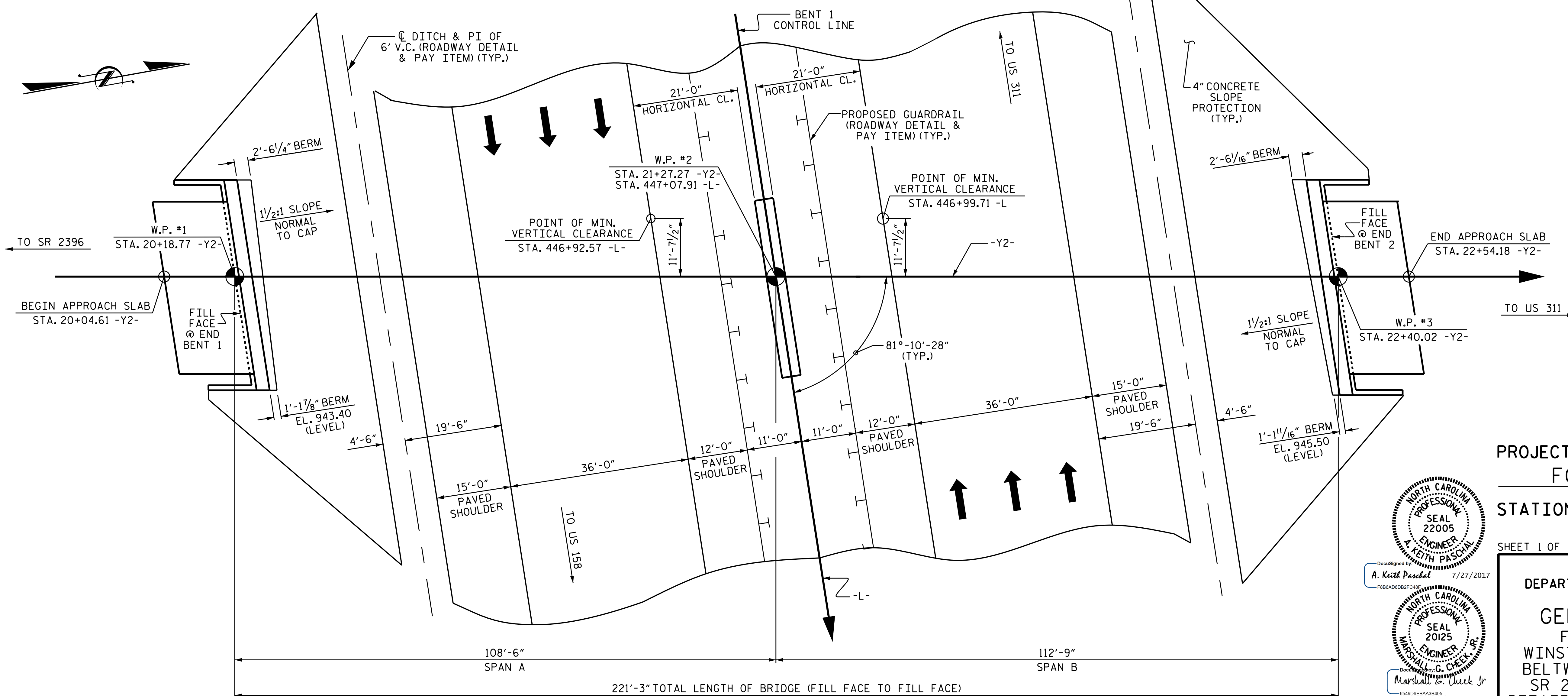

PROJECT NO. U-2579C
 FORSYTH COUNTY
 STATION: 447+07.91 -L-
21+27.27 -Y2-
 SHEET 1 OF 3 BRIDGE NO. 701

Professional Engineer Seal for Keith Paschal, No. 22005, dated 7/27/2017.
 Professional Engineer Seal for Marshall G. Check, Jr., No. 20125, dated 7/27/2017.

STATE OF NORTH CAROLINA
 DEPARTMENT OF TRANSPORTATION
 RALEIGH
GENERAL DRAWING
 FOR BRIDGE OVER
 WINSTON-SALEM NORTHERN
 BELTWAY (FUTURE I-74) ON
 SR 2381 (WILLISTON RD.)
 BETWEEN SR 2396 AND US 311

DRAWN BY: ARIADNE L. PALMA P. DATE: 09/19/16
 CHECKED BY: I. L. AVERETTE DATE: 04/24/17
 DESIGN ENGINEER OF RECORD: H. A. LOCKLEAR DATE: 6/2017

PLAN
 (PILES, COLUMNS, & FOOTINGS NOT SHOWN FOR CLARITY)

DOCUMENT NOT CONSIDERED FINAL UNLESS ALL SIGNATURES COMPLETED

REVISIONS						SHEET NO.
NO.	BY:	DATE:	NO.	BY:	DATE:	S2-1
1			3			TOTAL SHEETS
2			4			30

NOTES

FOR PILES, SEE GEOTECHNICAL SPECIAL PROVISIONS AND SECTION 450 OF THE STANDARD SPECIFICATIONS.

PILES AT END BENT 1 AND END BENT 2 ARE DESIGNED FOR A FACTORED RESISTANCE OF 115 TONS PER PILE.

DRIVE PILES AT END BENT 1 AND END BENT 2 TO A REQUIRED DRIVING RESISTANCE OF 195 TONS PER PILE.

PILES AT BENT 1 ARE DESIGNED FOR A FACTORED RESISTANCE OF 135 TONS PER PILE. DRIVE PILES AT BENT 1 TO A REQUIRED DRIVING RESISTANCE OF 225 TONS PER PILE.

STEEL H-PILE POINTS ARE REQUIRED FOR STEEL H-PILES AT BENT 1. FOR STEEL PILE POINTS, SEE SECTION 450 OF THE STANDARD SPECIFICATIONS.

TESTING PILES WITH THE PILE DRIVING ANALYZER (PDA) DURING DRIVING, RESTRIKING, OR REDRIVING MAY BE REQUIRED. THE ENGINEER WILL DETERMINE THE NEED FOR PDA TESTING. FOR PDA TESTING, SEE SECTION 450 OF THE STANDARD SPECIFICATIONS.

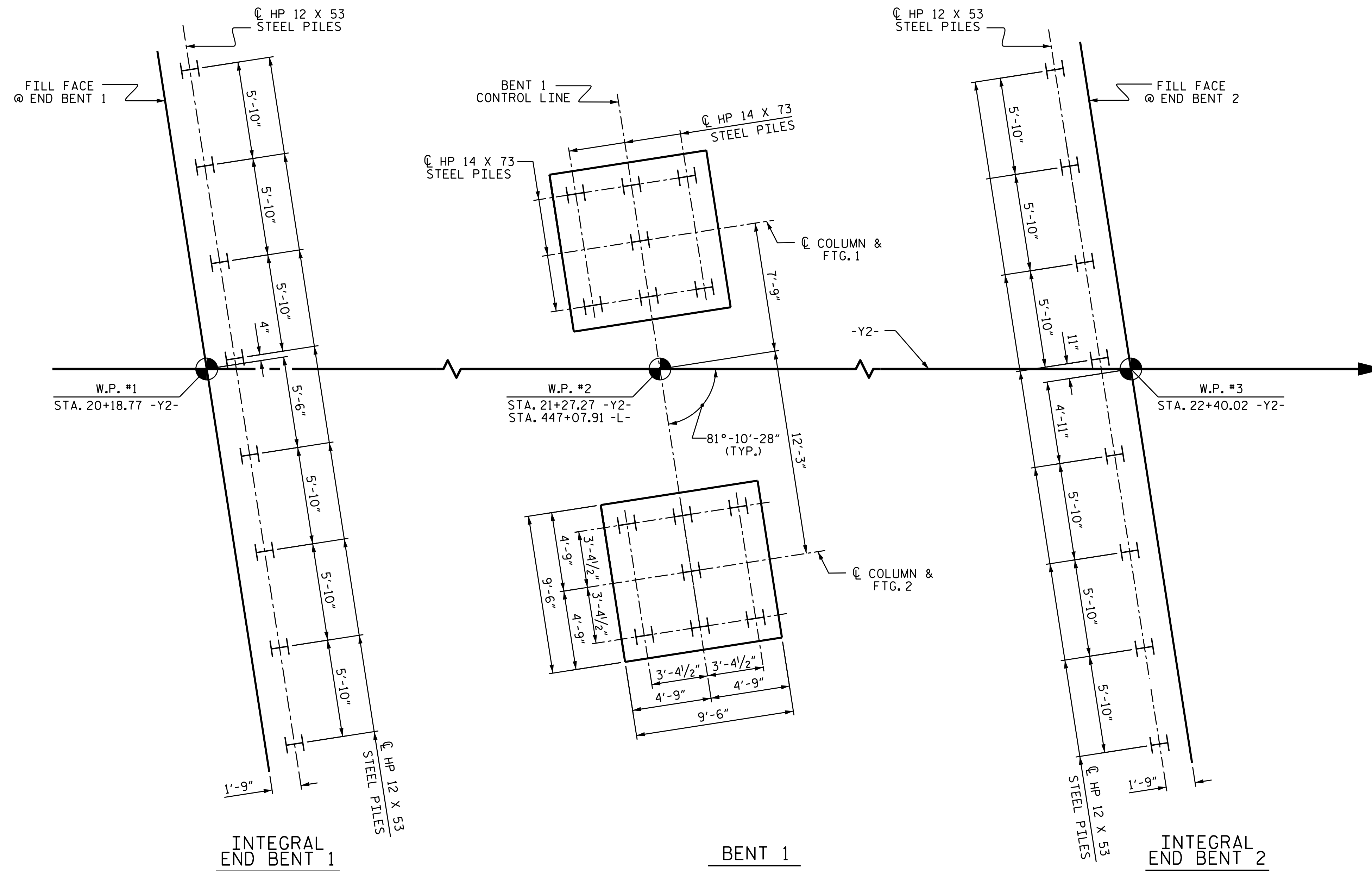

FOUNDATION LAYOUT

DIMENSIONS LOCATING PILES ARE SHOWN TO THE CENTERLINE OF PILES. ALL COLUMN FOOTINGS AND PILE SPACINGS ARE TYPICAL AT BENT.

PROJECT NO. U-2579C
 FORSYTH COUNTY
 STATION: 447+07.91 -L-
21+27.27 -Y2-
 SHEET 2 OF 3



STATE OF NORTH CAROLINA
 DEPARTMENT OF TRANSPORTATION
 RALEIGH
GENERAL DRAWING
 FOR BRIDGE OVER
 WINSTON-SALEM NORTHERN
 BELTWAY (FUTURE I-74) ON
 SR 2381 (WILLISTON RD.)
 BETWEEN SR 2396 AND US 311

DRAWN BY : ARIADNE L. PALMA P. DATE : 09/28/16
 CHECKED BY : I. L. AVERETTE DATE : 04/24/17
 DESIGN ENGINEER OF RECORD: H. A. LOCKLEAR DATE : 6/2017

DOCUMENT NOT CONSIDERED
 FINAL UNLESS ALL
 SIGNATURES COMPLETED

REVISIONS						SHEET NO.
NO.	BY:	DATE:	NO.	BY:	DATE:	TOTAL SHEETS
1			3			S2-2
2			4			30

BENCHMARK #3: RR SPIKE SET IN BASE OF 30" OAK TREE, 120' LT. OF STA. 31+99 -Y2-, EL. 957.76

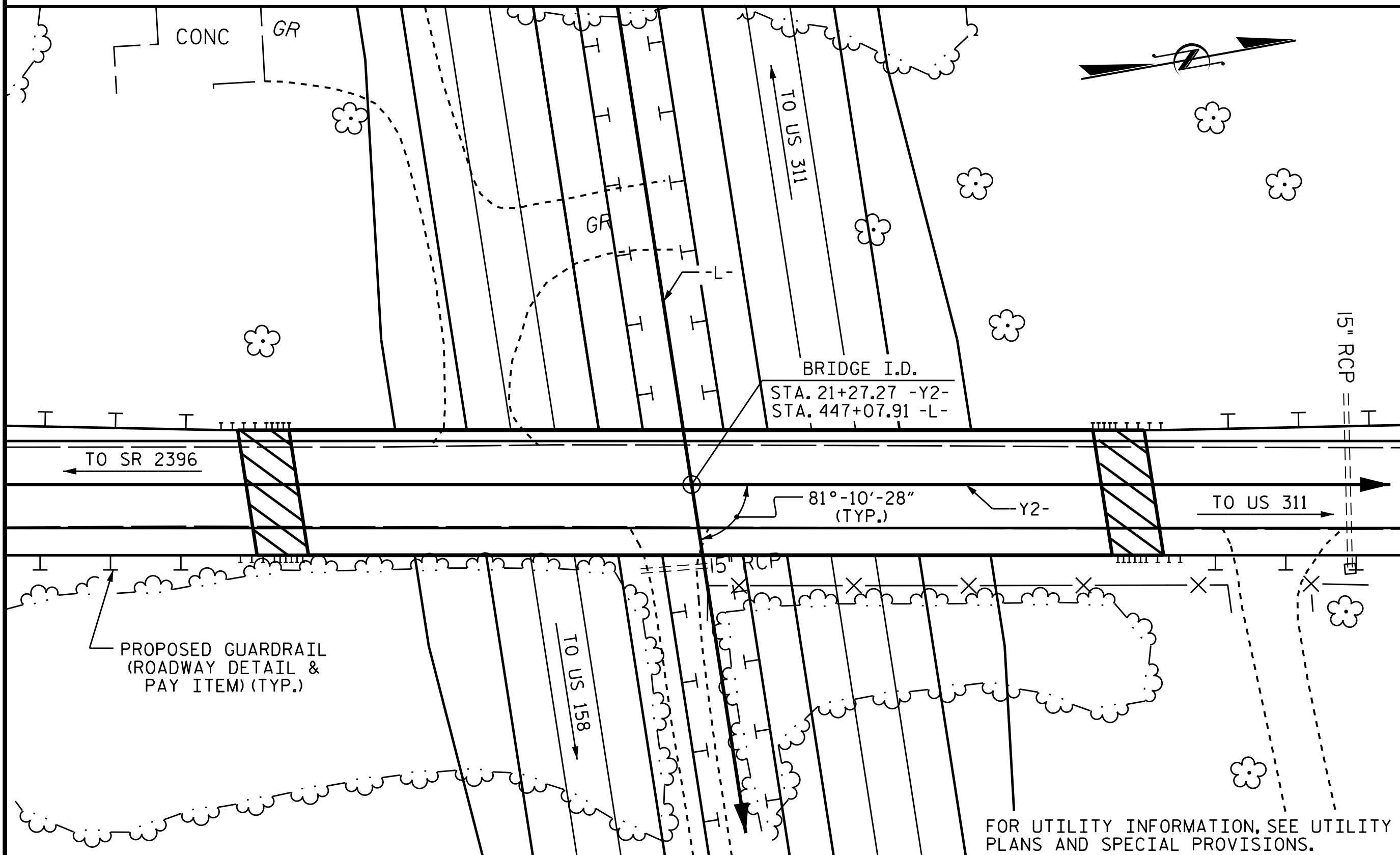

LOCATION SKETCH

NOTES

- ASSUMED LIVE LOAD = HL-93 OR ALTERNATE LOADING.
- THIS BRIDGE HAS BEEN DESIGNED IN ACCORDANCE WITH THE AASHTO LRFD BRIDGE DESIGN SPECIFICATIONS.
- THIS BRIDGE IS LOCATED IN SEISMIC ZONE 1.
- FOR OTHER DESIGN DATA AND GENERAL NOTES, SEE SHEET SN.
- FOR SUBMITTAL OF WORKING DRAWINGS, SEE SPECIAL PROVISIONS.
- FOR FALSEWORK AND FORMWORK, SEE SPECIAL PROVISIONS.
- FOR CRANE SAFETY, SEE SPECIAL PROVISIONS.
- FOR GROUT FOR STRUCTURES, SEE SPECIAL PROVISIONS.
- REMOVABLE FORMS MAY BE USED IN LIEU OF METAL STAY-IN-PLACE FORMS IN ACCORDANCE WITH ARTICLE 420-3 OF THE STANDARD SPECIFICATIONS.
- NEEDLE BEAMS WILL NOT BE ALLOWED UNLESS OTHERWISE CALLED FOR ON THE PLANS OR APPROVED BY THE ENGINEER.
- THE CONTRACTOR SHALL PROVIDE INDEPENDENT ASSURANCE SAMPLES OF REINFORCING STEEL AS FOLLOWS: FOR PROJECTS REQUIRING UP TO 400 TONS OF REINFORCING STEEL, ONE 30 INCH SAMPLE OF EACH SIZE BAR USED, AND FOR PROJECTS REQUIRING OVER 400 TONS OF REINFORCING STEEL, TWO 30 INCH SAMPLES OF EACH SIZE BAR USED. THE BARS FROM WHICH THE SAMPLES ARE TAKEN MUST THEN BE SPLICED WITH REPLACEMENT BARS OF THE SIZE AND LENGTH OF THE SAMPLE, PLUS A MINIMUM LAP SPLICE OF THIRTY BAR DIAMETERS. PAYMENT FOR THE SAMPLES OF REINFORCING STEEL SHALL BE CONSIDERED INCIDENTAL TO VARIOUS PAY ITEMS.
- THE CLASS AA CONCRETE IN THE BRIDGE DECK SHALL CONTAIN FLY ASH OR GROUND GRANULATED BLAST FURNACE SLAG AT THE SUBSTITUTION RATE SPECIFIED IN ARTICLE 1024-1 AND IN ACCORDANCE WITH ARTICLES 1024-5 AND 1024-6 OF THE STANDARD SPECIFICATIONS. NO PAYMENT WILL BE MADE FOR THIS SUBSTITUTION AS IT IS CONSIDERED INCIDENTAL TO THE COST OF THE REINFORCED CONCRETE DECK SLAB.
- FOR EROSION CONTROL MEASURES, SEE EROSION CONTROL PLANS.
- THE ELEVATIONS AND CLEARANCES SHOWN ON THE PLANS AT THE POINTS OF MINIMUM VERTICAL CLEARANCE ARE FROM THE BEST INFORMATION AVAILABLE. PRIOR TO BEGINNING BRIDGE CONSTRUCTION, VERIFY THE ELEVATIONS ON THE EXISTING PAVEMENT AND CHECK THE CLEARANCE. REPORT ANY VARIATIONS TO THE ENGINEER. ANY PLAN REVISIONS NECESSARY TO ACHIEVE THE REQUIRED MINIMUM VERTICAL CLEARANCE WILL BE PROVIDED BY THE DEPARTMENT.
- FOR PLACING LOAD ON STRUCTURE MEMBERS, SEE SPECIAL PROVISIONS.
- FOR EMBEDDED CLIPS FOR PRESTRESSED CONCRETE GIRDERS, SEE SPECIAL PROVISIONS.

TOTAL BILL OF MATERIAL

	FOUNDATION EXCAVATION FOR BENT	PDA TESTING	REINFORCED CONCRETE DECK SLAB	GROOVING BRIDGE FLOORS	CLASS A CONCRETE	BRIDGE APPROACH SLABS	REINFORCING STEEL	SPIRAL COLUMN REINFORCING STEEL	MODIFIED 72" PRESTRESSED CONCRETE GIRDERS	PILE DRIVING EQUIPMENT SETUP FOR HP 12 X 53 STEEL PILES	PILE DRIVING EQUIPMENT SETUP FOR HP 14 X 73 STEEL PILES	HP 12 X 53 STEEL PILES	HP 14 X 73 STEEL PILES	STEEL PILE POINTS	TWO BAR METAL RAIL	1'-2" X 3'-2 3/4" CONCRETE PARAPET	4" SLOPE PROTECTION	ELASTOMERIC BEARINGS
	LUMP SUM	EACH	SQ. FT.	SQ. FT.	CU. YDS.	LUMP SUM	LBS.	LBS.	NO. LIN. FT.	EACH	EACH	NO. LIN. FT.	NO. LIN. FT.	EACH	LIN. FT.	LIN. FT.	SQ. YDS.	LUMP SUM
SUPERSTRUCTURE			8,205	6,442		LUMP SUM			8 873.17						423.76	439.13		LUMP SUM
END BENT 1					34.6		4258			8		8 360					295	
BENT 1	LUMP SUM				59.0		9204	1012			14		14 350	14				
END BENT 2					35.8		4385			8		8 460					368	
TOTAL	LUMP SUM	1	8,205	6,442	129.4	LUMP SUM	17847	1012	8 873.17	16	14	16 820	14 350	14	423.76	439.13	663	LUMP SUM

PROJECT NO. U-2579C
FORSYTH COUNTY
 STATION: 447+07.91 -L-
21+27.27 -Y2-
 SHEET 3 OF 3



STATE OF NORTH CAROLINA
 DEPARTMENT OF TRANSPORTATION
 RALEIGH
GENERAL DRAWING
 FOR BRIDGE OVER
 WINSTON-SALEM NORTHERN
 BELTWAY (FUTURE I-74) ON
 SR 2381 (WILLISTON RD.)
 BETWEEN SR 2396 AND US 311

DRAWN BY : ARIADNE L. PALMA P. DATE : 09/30/16
 CHECKED BY : T. L. AVERETTE DATE : 04/24/17

DOCUMENT NOT CONSIDERED
 FINAL UNLESS ALL
 SIGNATURES COMPLETED

REVISIONS						SHEET NO.
NO.	BY:	DATE:	NO.	BY:	DATE:	S2-3
1			3			TOTAL SHEETS
2			4			30

LOAD FACTORS:

DESIGN LOAD RATING FACTORS	LIMIT STATE	γ_{DC}	γ_{DW}
	STRENGTH I	1.25	1.50
	SERVICE III	1.00	1.00

LOAD AND RESISTANCE FACTOR RATING (LRFD) SUMMARY FOR PRESTRESSED CONCRETE GIRDERS

LEVEL	VEHICLE	WEIGHT (W) (TONS)	CONTROLLING LOAD RATING	MINIMUM RATING FACTORS (RF)	TONS = W X RF	STRENGTH I LIMIT STATE										SERVICE III LIMIT STATE					COMMENT NUMBER			
						LIVELOAD FACTORS	MOMENT					SHEAR					LIVELOAD FACTORS	MOMENT						
							DISTRIBUTION FACTORS (DF)	RATING FACTOR	SPAN	GIRDER LOCATION	DISTANCE FROM LEFT END OF SPAN (ft)	DISTRIBUTION FACTORS (DF)	RATING FACTOR	SPAN	GIRDER LOCATION	DISTANCE FROM LEFT END OF SPAN (ft)		DISTRIBUTION FACTORS (DF)	RATING FACTOR	SPAN		GIRDER LOCATION	DISTANCE FROM LEFT END OF SPAN (ft)	
DESIGN LOAD RATING	HL-93(Inv)	N/A	1	1.02	--	1.75	0.989	1.52	B	ER	54.927	1.009	1.1	A	ER	10.56	0.80	0.989	1.02	B	ER	54.927		
	HL-93(0pr)	N/A	--	1.42	--	1.35	0.989	1.97	B	ER	54.927	1.009	1.42	A	ER	10.56	N/A	--	--	--	--	--		
	HS-20(Inv)	36.000	2	1.45	52.200	1.75	0.989	2.17	B	ER	54.927	1.009	1.47	A	ER	10.56	0.80	0.989	1.45	B	ER	54.927		
	HS-20(0pr)	36.000	--	1.91	68.642	1.35	0.989	2.82	B	ER	54.927	1.009	1.91	A	ER	10.56	N/A	--	--	--	--	--		
LEGAL LOAD RATING	SV	SNSH	13.500	--	3.48	47.028	1.4	0.989	6.53	B	ER	54.927	1.009	4.55	A	ER	10.56	0.80	0.989	3.48	B	ER	54.927	
		SNGARBS2	20.000	--	2.5	50.073	1.4	0.989	4.69	B	ER	54.927	1.009	3.18	A	ER	10.56	0.80	0.989	2.50	B	ER	54.927	
		SNAGRIS2	22.000	--	2.33	51.353	1.4	0.989	4.37	B	ER	54.927	1.009	2.93	A	ER	10.56	0.80	0.989	2.33	B	ER	54.927	
		SNCOTTS3	27.250	--	1.73	47.164	1.4	0.989	3.24	B	ER	54.927	1.009	2.26	A	ER	10.56	0.80	0.989	1.73	B	ER	54.927	
		SNAGGRS4	34.925	--	1.41	49.270	1.4	0.989	2.64	B	ER	54.927	1.009	1.84	A	ER	10.56	0.80	0.989	1.41	B	ER	54.927	
		SNS5A	35.550	--	1.38	49.127	1.4	0.989	2.59	B	ER	54.927	1.009	1.85	A	ER	10.56	0.80	0.989	1.38	B	ER	54.927	
		SNS6A	39.950	--	1.25	50.077	1.4	0.989	2.35	B	ER	54.927	1.009	1.67	A	ER	10.56	0.80	0.989	1.25	B	ER	54.927	
	SNS7B	42.000	--	1.19	50.113	1.4	0.989	2.24	B	ER	54.927	1.009	1.62	A	ER	10.56	0.80	0.989	1.19	B	ER	54.927		
	TTST	TNAGRIT3	33.000	--	1.52	50.303	1.4	0.989	2.86	B	ER	54.927	1.009	2	A	ER	10.56	0.80	0.989	1.52	B	ER	54.927	
		TNT4A	33.075	--	1.53	50.512	1.4	0.989	2.86	B	ER	54.927	1.009	1.96	A	ER	10.56	0.80	0.989	1.53	B	ER	54.927	
		TNT6A	41.600	--	1.24	51.389	1.4	0.989	2.31	B	ER	54.927	1.009	1.69	A	ER	10.56	0.80	0.989	1.24	B	ER	54.927	
		TNT7A	42.000	--	1.23	51.848	1.4	0.989	2.31	B	ER	54.927	1.009	1.67	A	ER	10.56	0.80	0.989	1.23	B	ER	54.927	
		TNT7B	42.000	--	1.26	52.923	1.4	0.989	2.36	B	ER	54.927	1.009	1.6	A	ER	10.56	0.80	0.989	1.26	B	ER	54.927	
		TNAGRIT4	43.000	--	1.21	52.086	1.4	0.989	2.27	B	ER	54.927	1.009	1.55	A	ER	10.56	0.80	0.989	1.21	B	ER	54.927	
TNAGT5A		45.000	--	1.15	51.664	1.4	0.989	2.15	B	ER	54.927	1.009	1.52	A	ER	10.56	0.80	0.989	1.15	B	ER	54.927		
TNAGT5B	45.000	3	1.14	51.282	1.4	0.989	2.13	B	ER	54.927	1.009	1.48	A	ER	10.56	0.80	0.989	1.14	B	ER	54.927			

NOTES:

MINIMUM RATING FACTORS ARE BASED ON THE STRENGTH I AND SERVICE III LIMIT STATES.
ALLOWABLE STRESSES FOR SERVICE III LIMIT STATE ARE AS REQUIRED FOR DESIGN.

#	CONTROLLING LOAD RATING
1	DESIGN LOAD RATING (HL-93)
2	DESIGN LOAD RATING (HS-20)
3	LEGAL LOAD RATING **
** SEE CHART FOR VEHICLE TYPE	
GIRDER LOCATION	
I - INTERIOR GIRDER EL - EXTERIOR LEFT GIRDER ER - EXTERIOR RIGHT GIRDER	

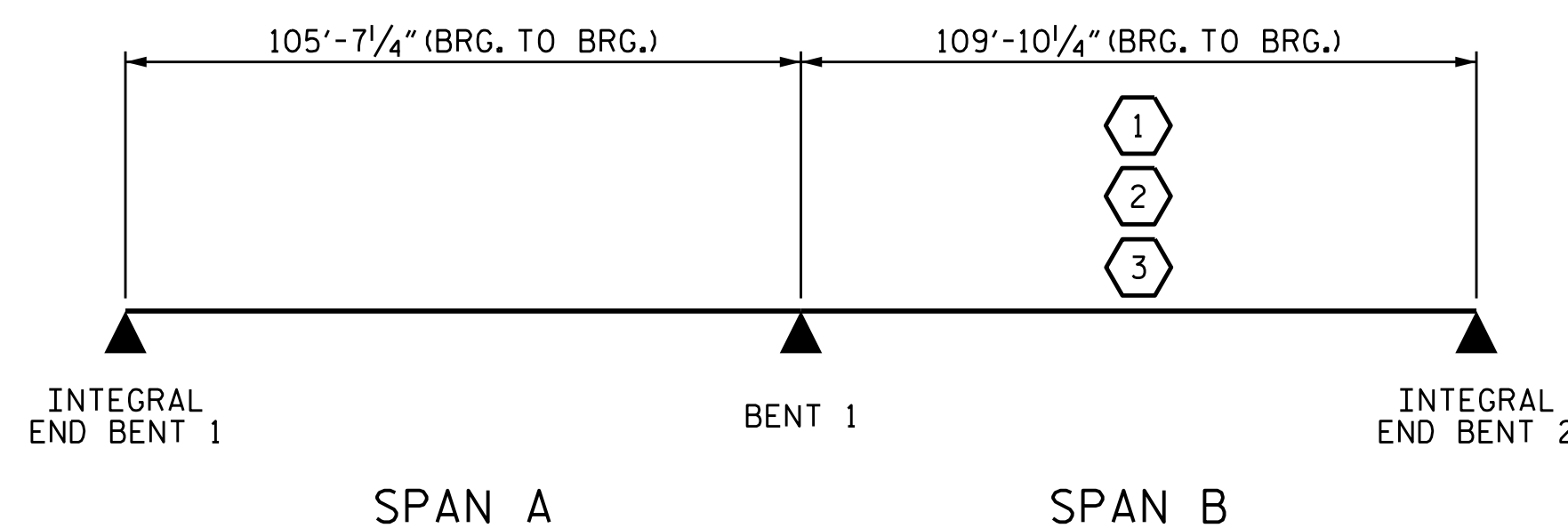

LRFR SUMMARY

PROJECT NO. U-2579C
FORSYTH COUNTY
 STATION: 21+27.27 -Y2-

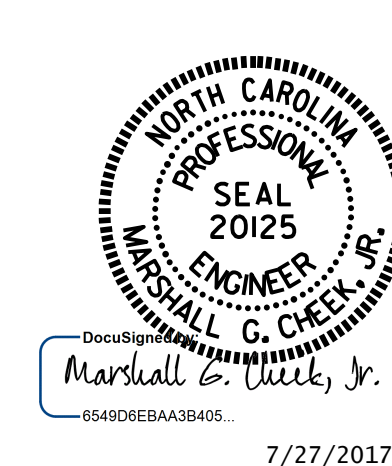

STATE OF NORTH CAROLINA
 DEPARTMENT OF TRANSPORTATION
 RALEIGH
 STANDARD
 LRFR SUMMARY FOR
 PRESTRESSED
 CONCRETE GIRDERS
 (NON-INTERSTATE TRAFFIC)

ASSEMBLED BY : J. K. BOWLES	DATE : 1/14/16
CHECKED BY : J. P. MCCARTHA	DATE : 1/14/16
DRAWN BY : MAA 1/08	REV. 11/27/08RR MAA/GM
CHECKED BY : GM/DI 2/08	REV. 10/1/11 MAA/GM

DOCUMENT NOT CONSIDERED FINAL UNLESS ALL SIGNATURES COMPLETED

REVISIONS						SHEET NO. S2-4
NO.	BY:	DATE:	NO.	BY:	DATE:	
1			3			TOTAL SHEETS 30
2			4			

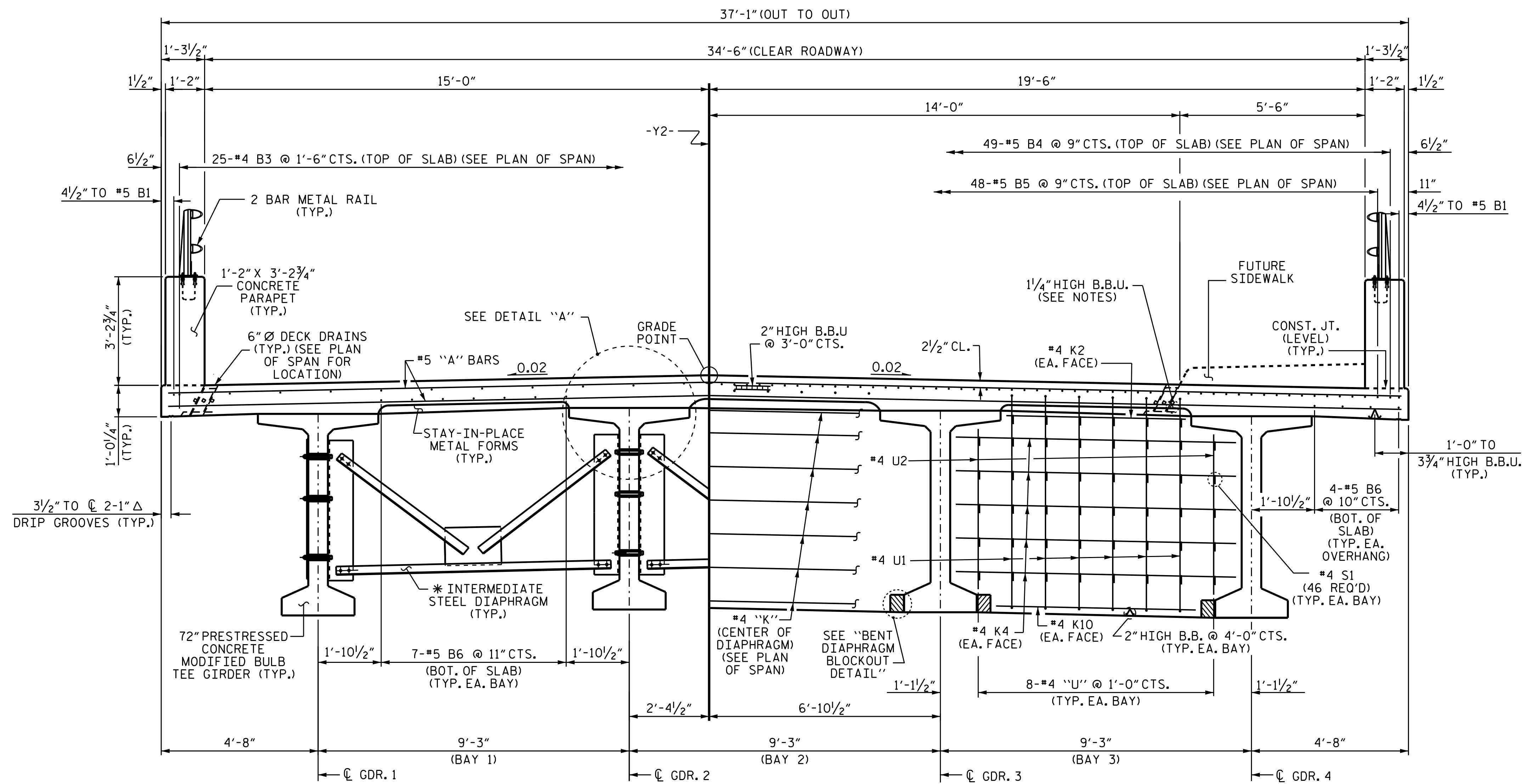

AT INTERMEDIATE DIAPHRAGMS

AT BENT DIAPHRAGMS

NOTES

PROVIDE 1/4" HIGH BEAM BOLSTERS UPPER AT 4'-0" CTS. ATOP THE METAL STAY-IN-PLACE FORMS TO SUPPORT THE BOTTOM MAT OF "A" BARS. WHEN USING REMOVABLE FORMS, PROVIDE CONTINUOUS HIGH CHAIRS FOR METAL DECK (C.H.C.M.) @ 4'-0" CTS. WITH A HEIGHT TO SUPPORT THE BOTTOM MAT OF "A" BARS A CLEAR DISTANCE OF 2 1/2" ABOVE THE TOP OF THE REMOVABLE FORM.

LONGITUDINAL STEEL MAY BE SHIFTED SLIGHTLY, AS NECESSARY, TO AVOID INTERFERENCE WITH STIRRUPS IN PRESTRESSED CONCRETE GIRDERS.

PREVIOUSLY CAST CONCRETE IN A CONTINUOUS UNIT SHALL HAVE ATTAINED A MINIMUM COMPRESSIVE STRENGTH OF 3,000 PSI BEFORE ADDITIONAL CONCRETE IS CAST IN THE UNIT.

* FOR INTERMEDIATE STEEL DIAPHRAGM DETAILS, SEE "INTERMEDIATE STEEL DIAPHRAGMS FOR 72" MODIFIED BULB TEE PRESTRESSED CONCRETE GIRDERS" SHEET.

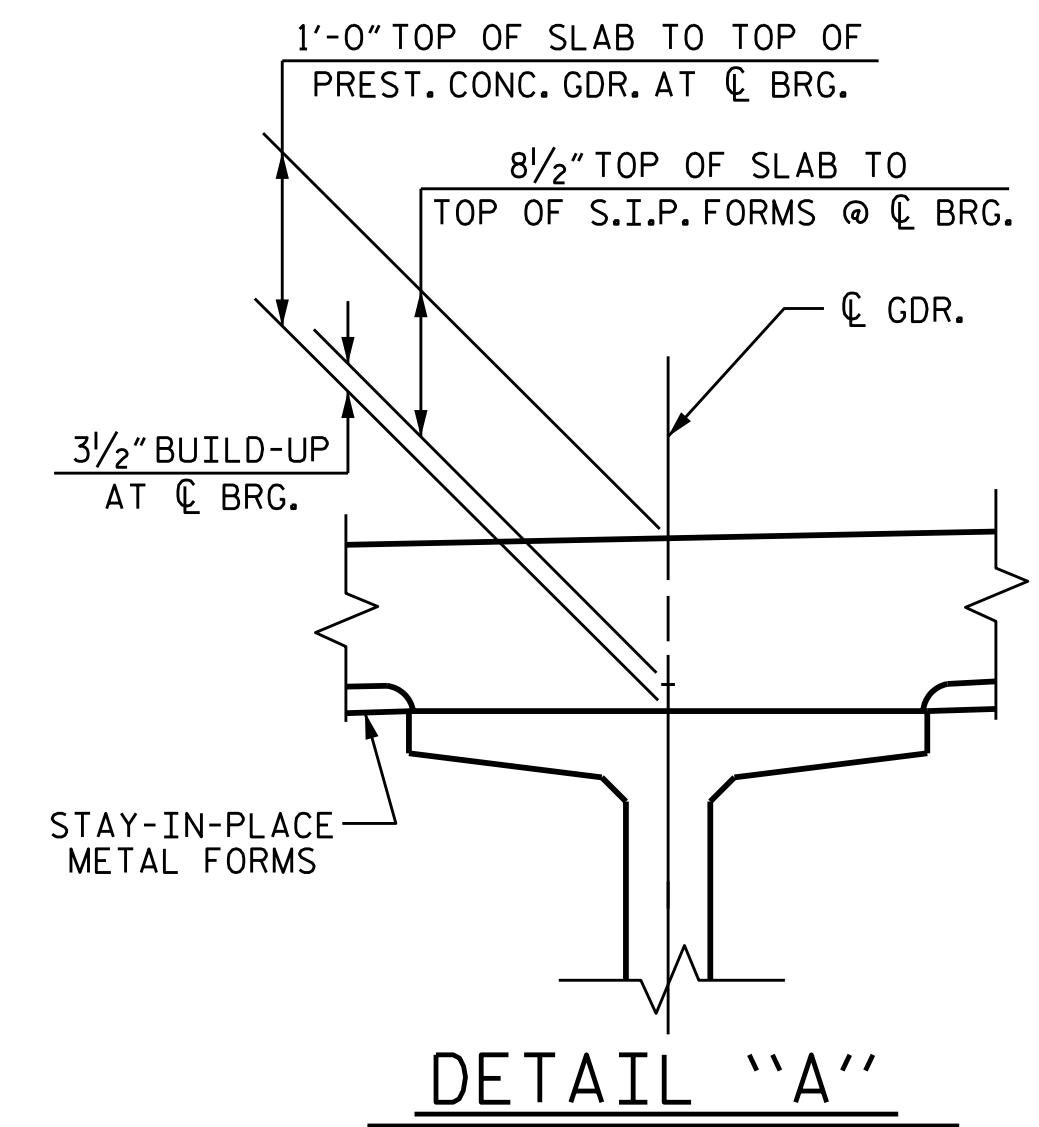

TYPICAL SECTION

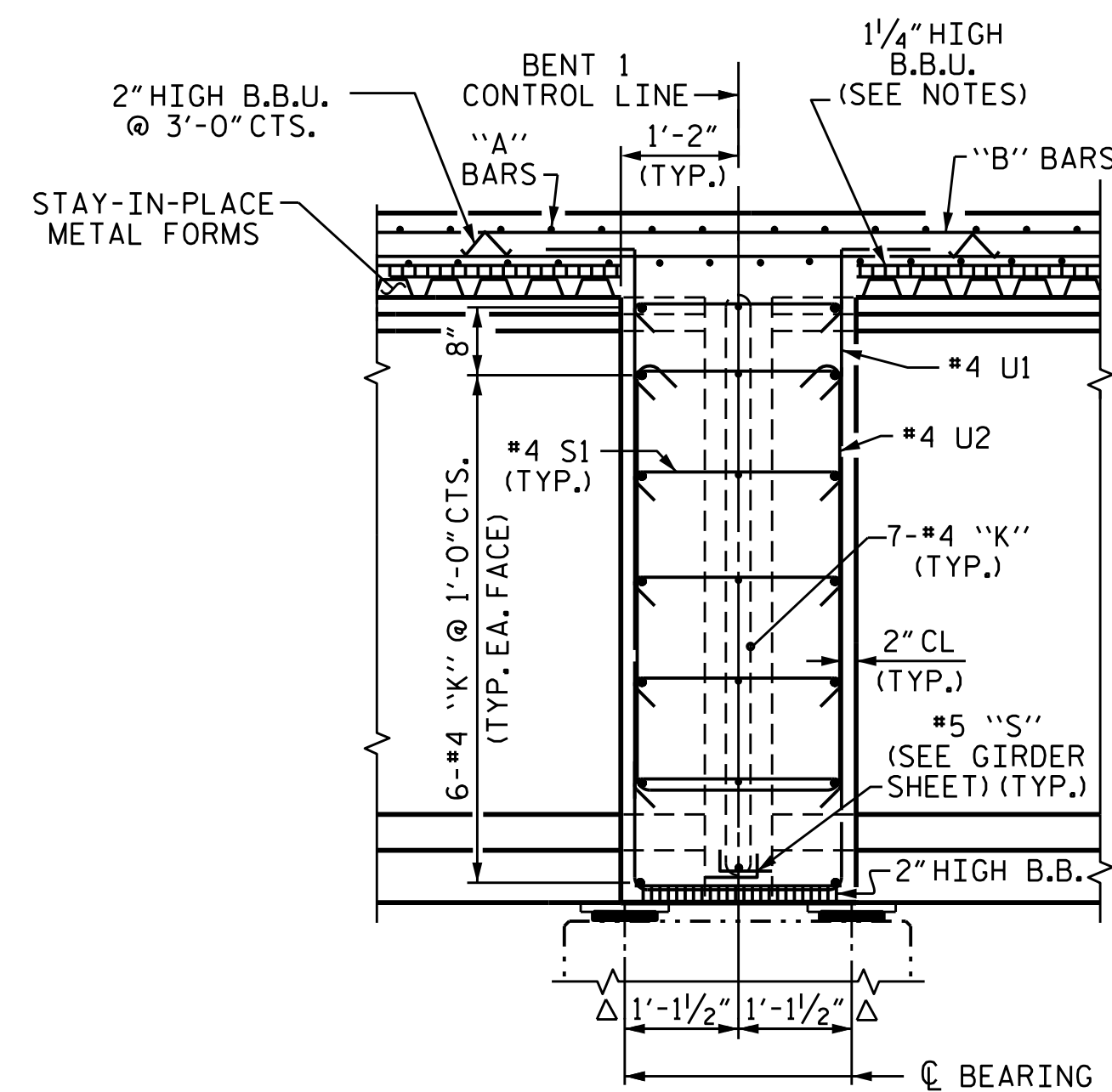

SECTION THROUGH BENT DIAPHRAGM

Δ MEASURED ALONG C GDR.

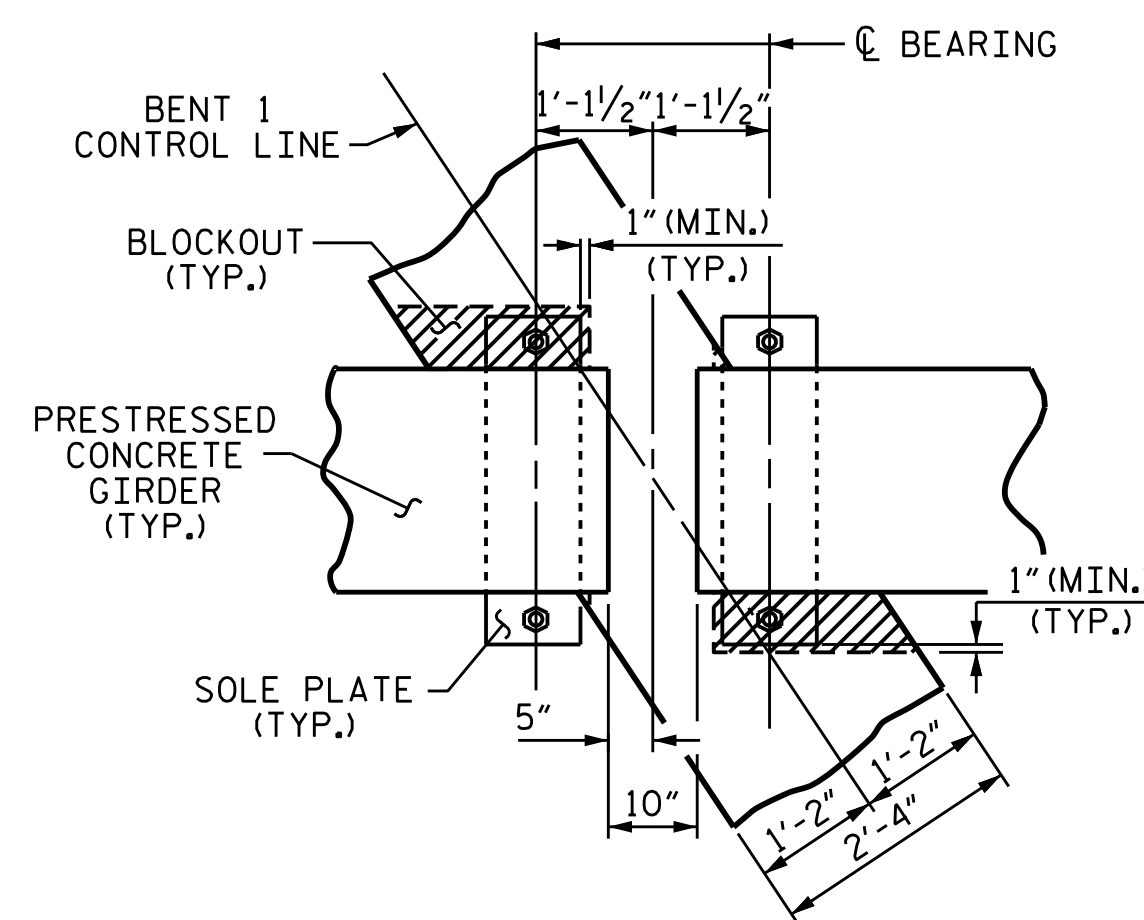

BENT DIAPHRAGM BLOCKOUT DETAIL

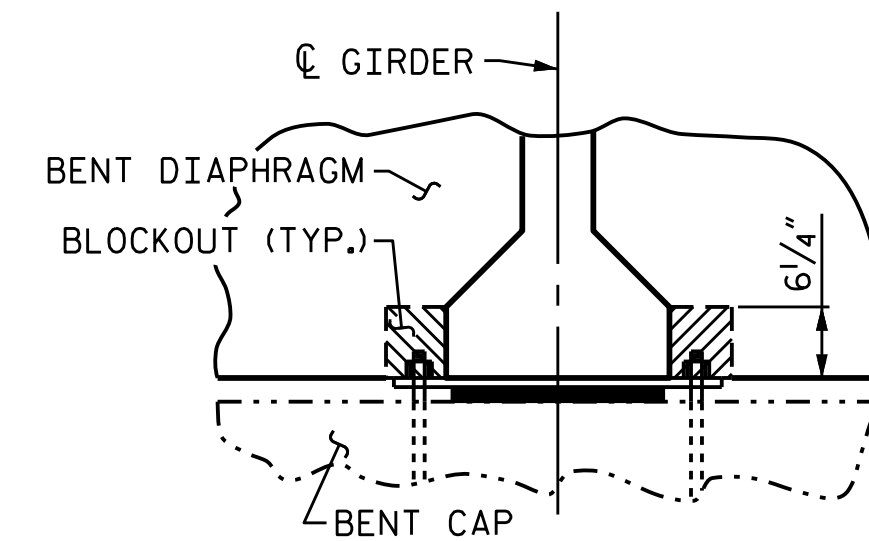

PROJECT NO. U-2579C
 FORSYTH COUNTY
 STATION: 21+27.27 -Y2-

SHEET 1 OF 2

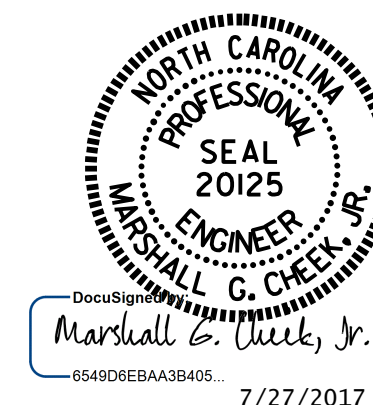

STATE OF NORTH CAROLINA
 DEPARTMENT OF TRANSPORTATION
 RALEIGH
 SUPERSTRUCTURE
 TYPICAL SECTION

DRAWN BY : N.D. AIUTO DATE : 1/13/16
 CHECKED BY : J.K. BOWLES DATE : 3/31/16
 DESIGN ENGINEER OF RECORD : J.K. BOWLES DATE : 3/31/16

DOCUMENT NOT CONSIDERED
 FINAL UNLESS ALL
 SIGNATURES COMPLETED

REVISIONS						SHEET NO.
NO.	BY:	DATE:	NO.	BY:	DATE:	S2-5
1			3			TOTAL SHEETS
2			4			30

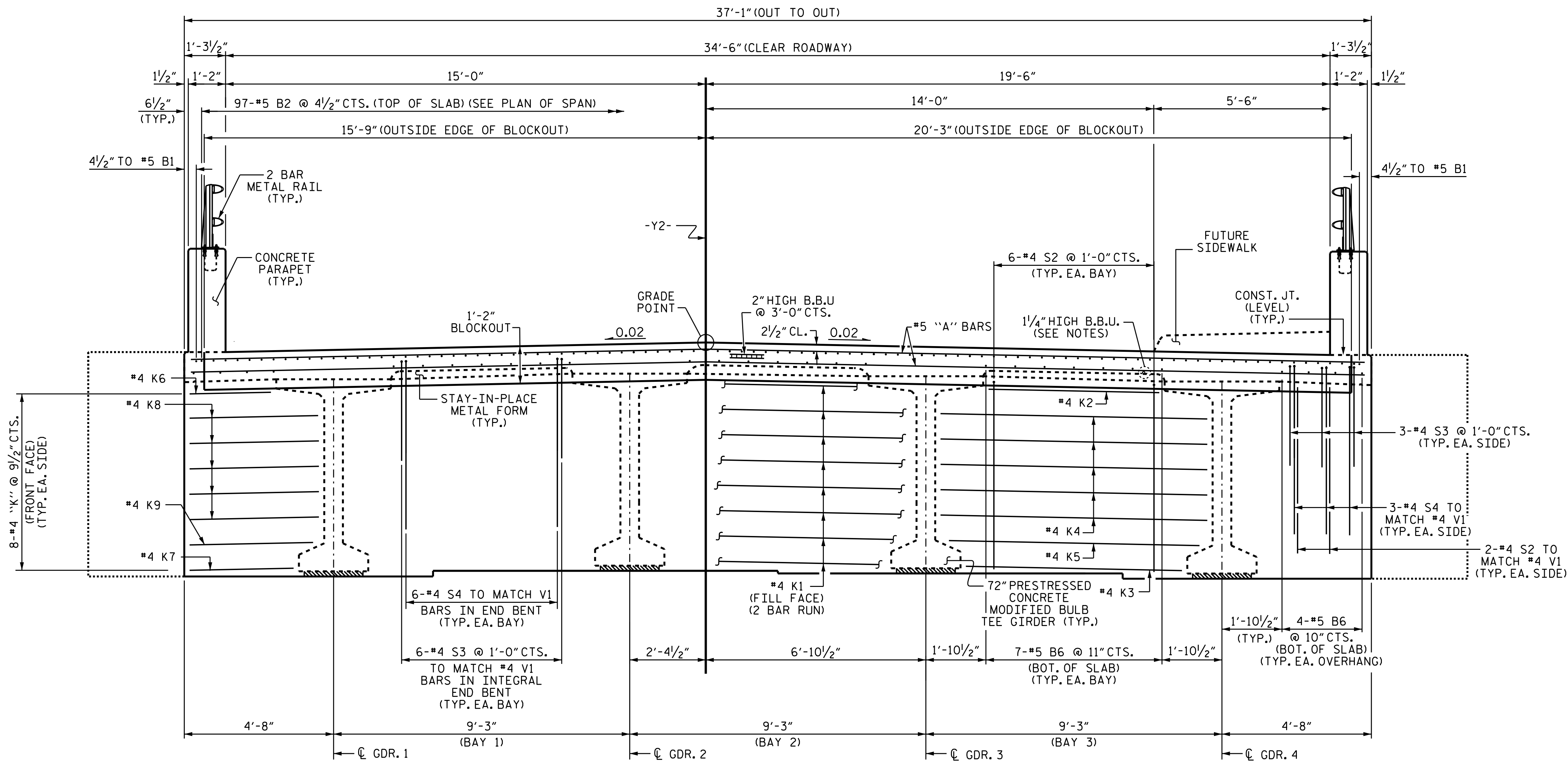

TYPICAL SECTION AT INTEGRAL END BENT

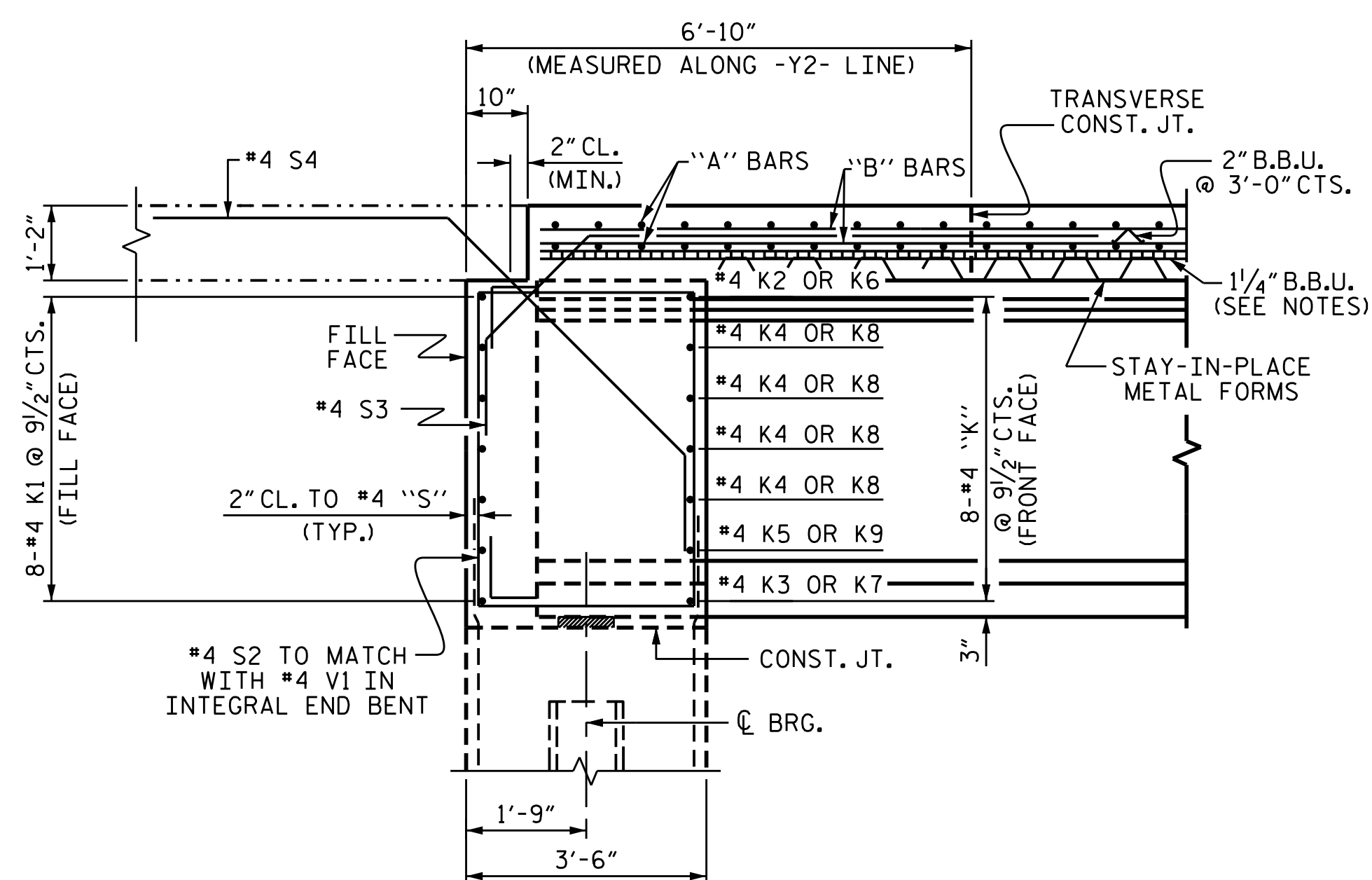

SECTION THROUGH INTEGRAL END BENT

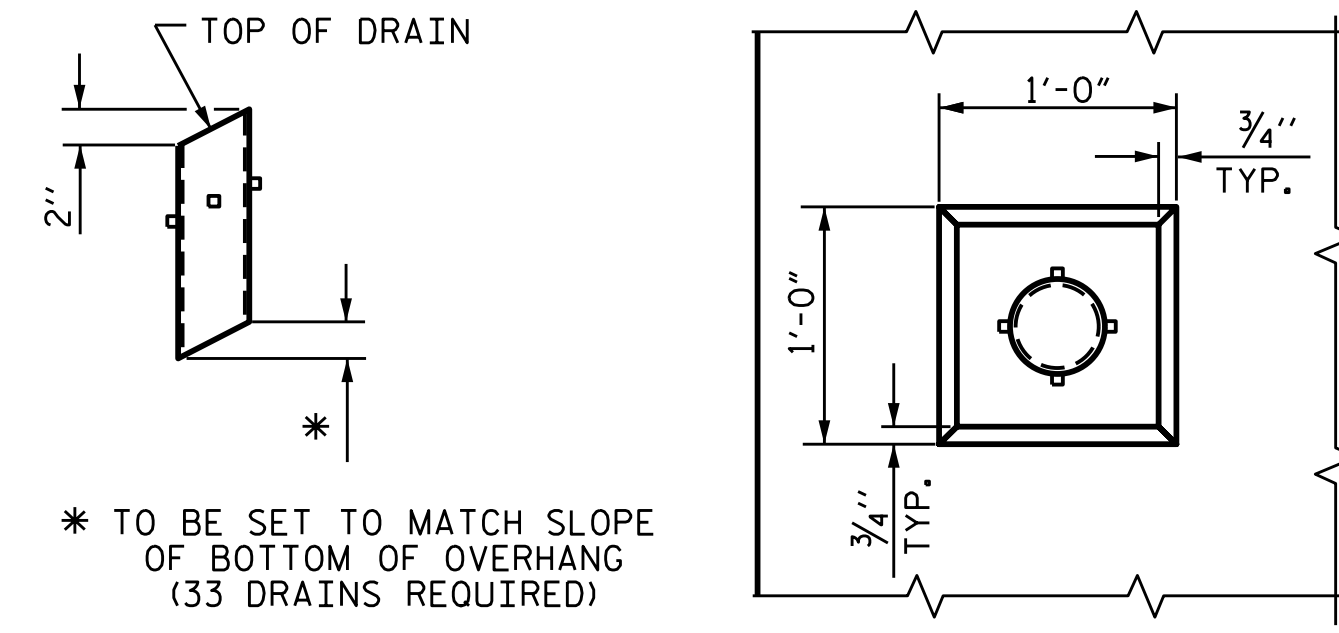

PIPE DETAIL

PLAN OF RECESS

TOP OF FLOOR DRAINS TO BE SET 3/8" BELOW SURFACE OF SLAB.
 4 - 1/2" SQUARE LUGS TO BE GLUED TO THE P.V.C. PIPE AT EQUAL SPACES AROUND THE PIPE DRAIN APPROXIMATELY 4" FROM THE TOP OF THE PIPE.
 THE 6" Ø PVC PIPE AND FITTINGS SHALL BE SCHEDULE 40 AND CONFORM TO ASTM D1785.

DRAIN DETAILS

THE ORIENTATION OF THE DRAINS ON THE RIGHT SIDE OF THE BRIDGE, IN FRONT OF THE PROPOSED SIDEWALK, SHALL BE PLACED SO THE WATER FLOW IS AWAY FROM THE EXTERIOR GIRDER.

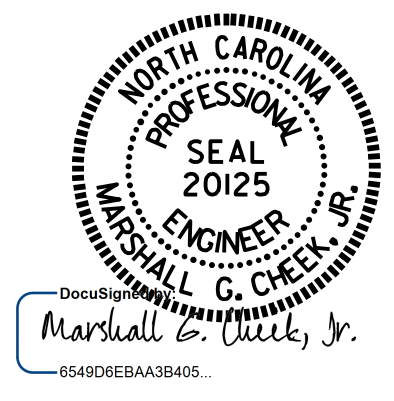

PROJECT NO. U-2579C
 FORSYTH COUNTY
 STATION: 21+27.27 -Y2-

SHEET 2 OF 2

STATE OF NORTH CAROLINA
 DEPARTMENT OF TRANSPORTATION
 RALEIGH
 SUPERSTRUCTURE
 TYPICAL SECTION

DRAWN BY : N.D. AIUTO DATE : 1/13/16
 CHECKED BY : J.K. BOWLES DATE : 3/31/16
 DESIGN ENGINEER OF RECORD : J.K. BOWLES DATE : 3/31/16

DOCUMENT NOT CONSIDERED FINAL UNLESS ALL SIGNATURES COMPLETED

REVISIONS						SHEET NO.
NO.	BY:	DATE:	NO.	BY:	DATE:	TOTAL SHEETS
1			3			S2-6
2			4			30

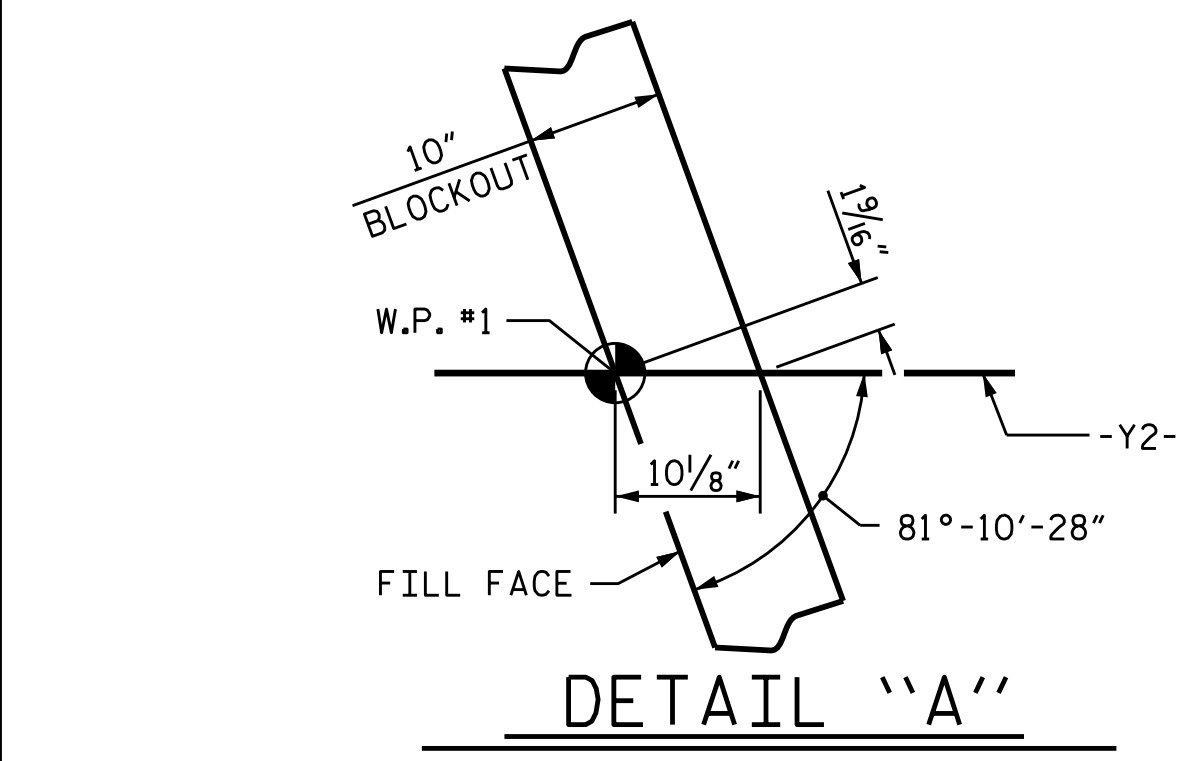
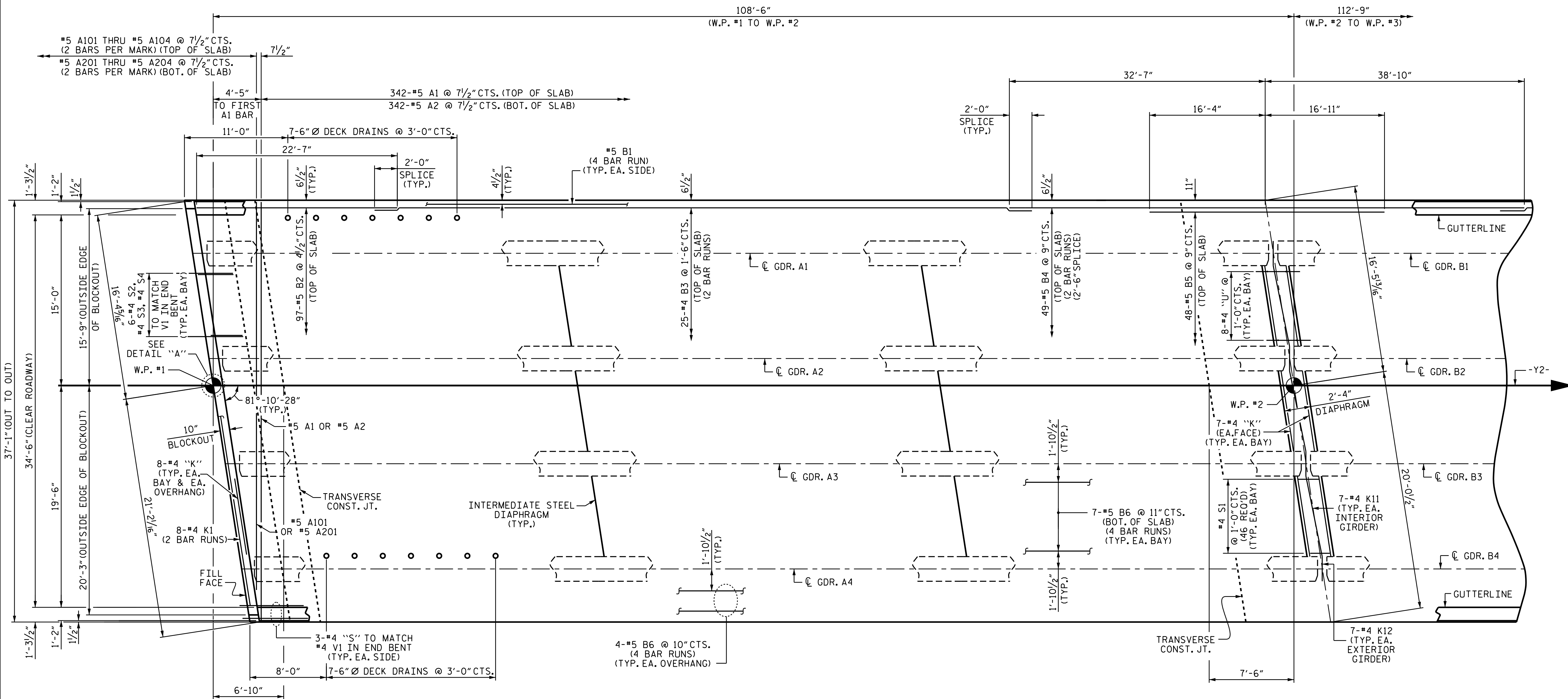

PLAN OF SPAN A
 FOR INTERMEDIATE STEEL DIAPHRAGMS,
 SEE "INTERMEDIATE STEEL DIAPHRAGMS FOR MODIFIED BULB
 TEE PRESTRESSED CONCRETE GIRDERS" SHEET.)

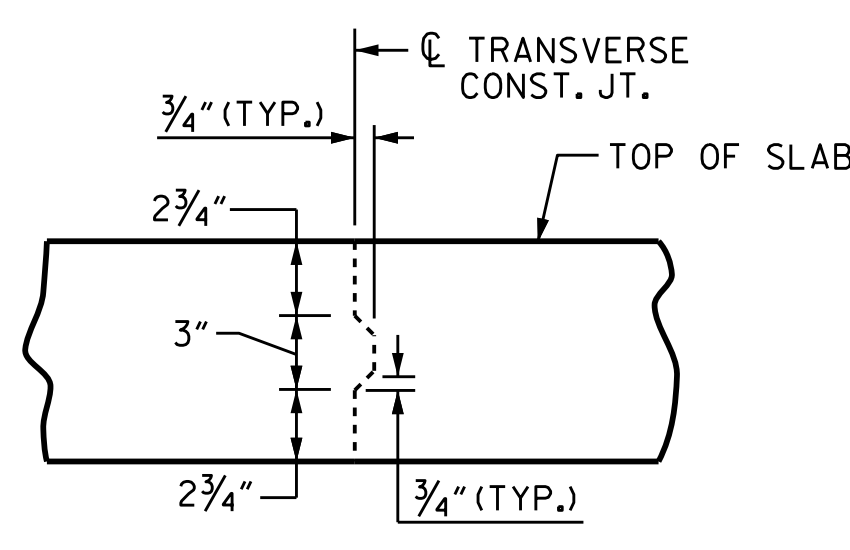

**TRANSVERSE
 CONSTRUCTION JOINT**
 NOTE: REINFORCING STEEL IN SLAB
 NOT SHOWN. LONGITUDINAL REINFORCING STEEL
 SHALL BE CONTINUOUS THROUGH JOINT.

PROJECT NO. U-2579C
FORSYTH COUNTY
 STATION: 21+27.27 -Y2-
 SHEET 1 OF 2

STATE OF NORTH CAROLINA
 DEPARTMENT OF TRANSPORTATION
 RALEIGH
 SUPERSTRUCTURE
 PLAN OF SPAN A

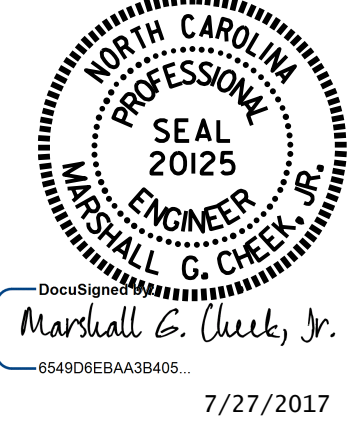

DRAWN BY: N.D. AIUTO DATE: 1/25/16
 CHECKED BY: J.K. BOWLES DATE: 3/31/16
 DESIGN ENGINEER OF RECORD: J.K. BOWLES DATE: 3/31/16

DOCUMENT NOT CONSIDERED
 FINAL UNLESS ALL
 SIGNATURES COMPLETED

REVISIONS						SHEET NO.
NO.	BY:	DATE:	NO.	BY:	DATE:	S2-7
1			3			TOTAL SHEETS
2			4			30

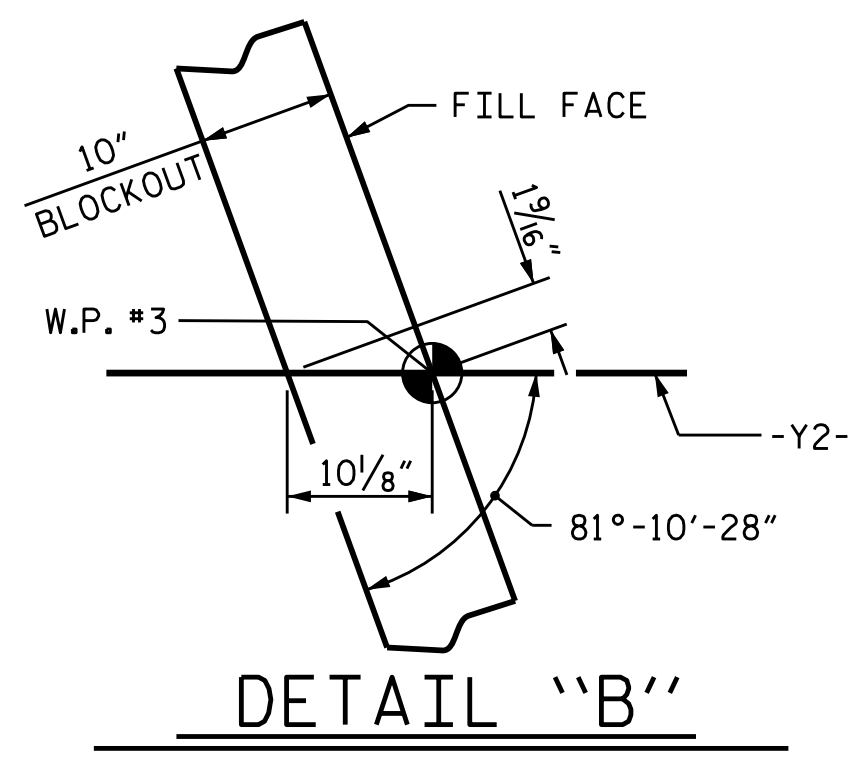
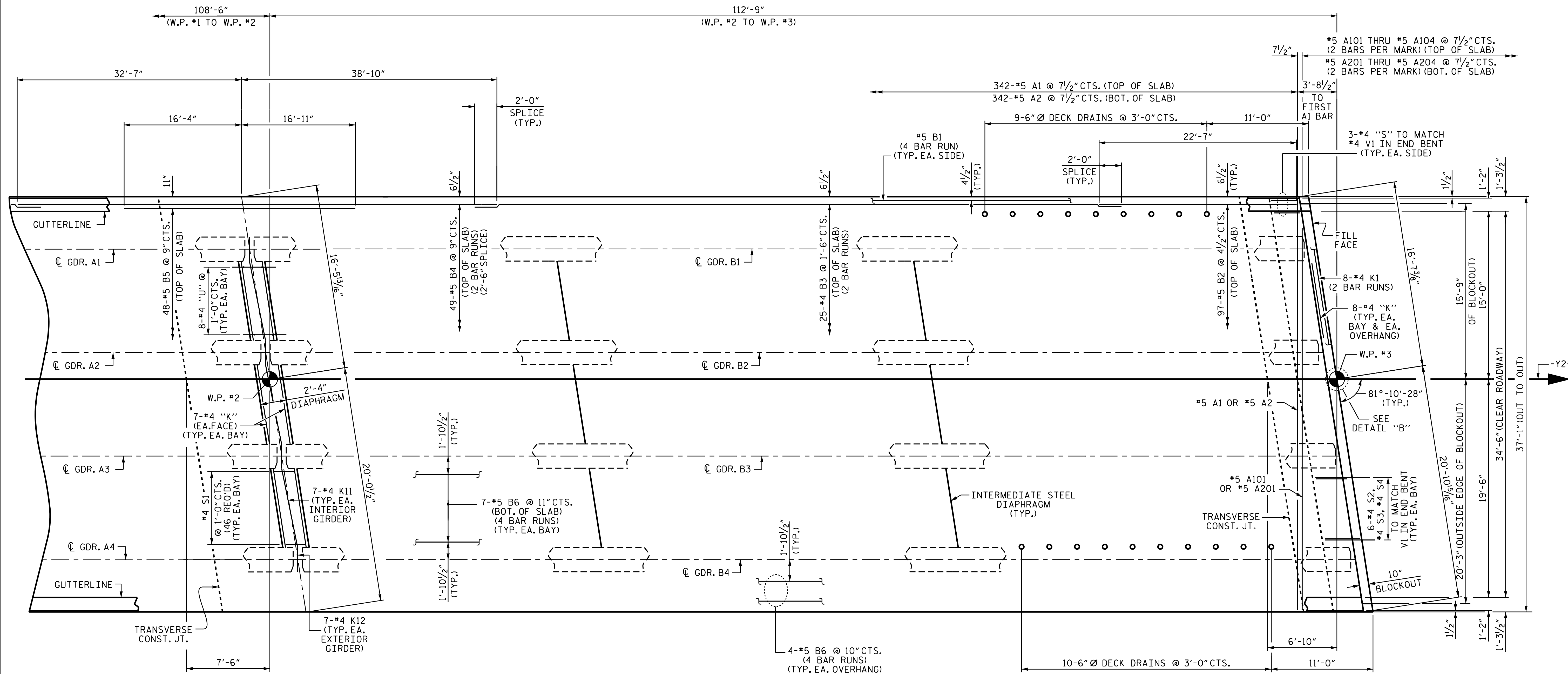

PLAN OF SPAN B
 FOR INTERMEDIATE STEEL DIAPHRAGMS,
 SEE "INTERMEDIATE STEEL DIAPHRAGMS FOR MODIFIED BULB
 TEE PRESTRESSED CONCRETE GIRDERS" SHEET.)

PROJECT NO. U-2579C
FORSYTH COUNTY
 STATION: 21+27.27 -Y2-

SHEET 2 OF 2



STATE OF NORTH CAROLINA
 DEPARTMENT OF TRANSPORTATION
 RALEIGH
 SUPERSTRUCTURE
 PLAN OF SPAN B

DRAWN BY: N.D. AIUTO DATE: 1/25/16
 CHECKED BY: J.K. BOWLES DATE: 3/31/16
 DESIGN ENGINEER OF RECORD: J.K. BOWLES DATE: 3/31/16

DOCUMENT NOT CONSIDERED
 FINAL UNLESS ALL
 SIGNATURES COMPLETED

REVISIONS						SHEET NO.
NO.	BY:	DATE:	NO.	BY:	DATE:	S2-8
1			3			TOTAL SHEETS
2			4			30

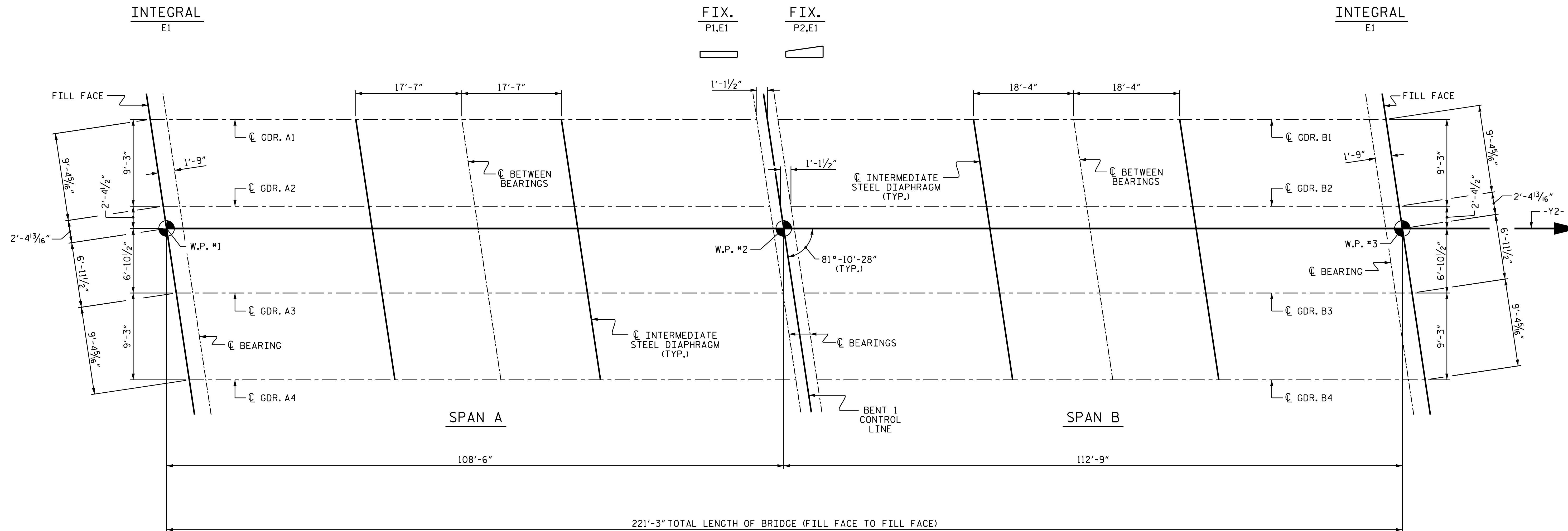

FRAMING PLAN

PROJECT NO. U-2579C
FORSYTH COUNTY
 STATION: 21+27.27 -Y2-



STATE OF NORTH CAROLINA
 DEPARTMENT OF TRANSPORTATION
 RALEIGH

**SUPERSTRUCTURE
 FRAMING PLAN**

DRAWN BY : N.D. AIUTO DATE : 1/21/16
 CHECKED BY : J. K. BOWLES DATE : 3/31/16
 DESIGN ENGINEER OF RECORD: J. K. BOWLES DATE : 3/31/16

DOCUMENT NOT CONSIDERED
 FINAL UNLESS ALL
 SIGNATURES COMPLETED

REVISIONS						SHEET NO.	
NO.	BY:	DATE:	NO.	BY:	DATE:	S2-9	
1			3			TOTAL SHEETS	
2			4			30	

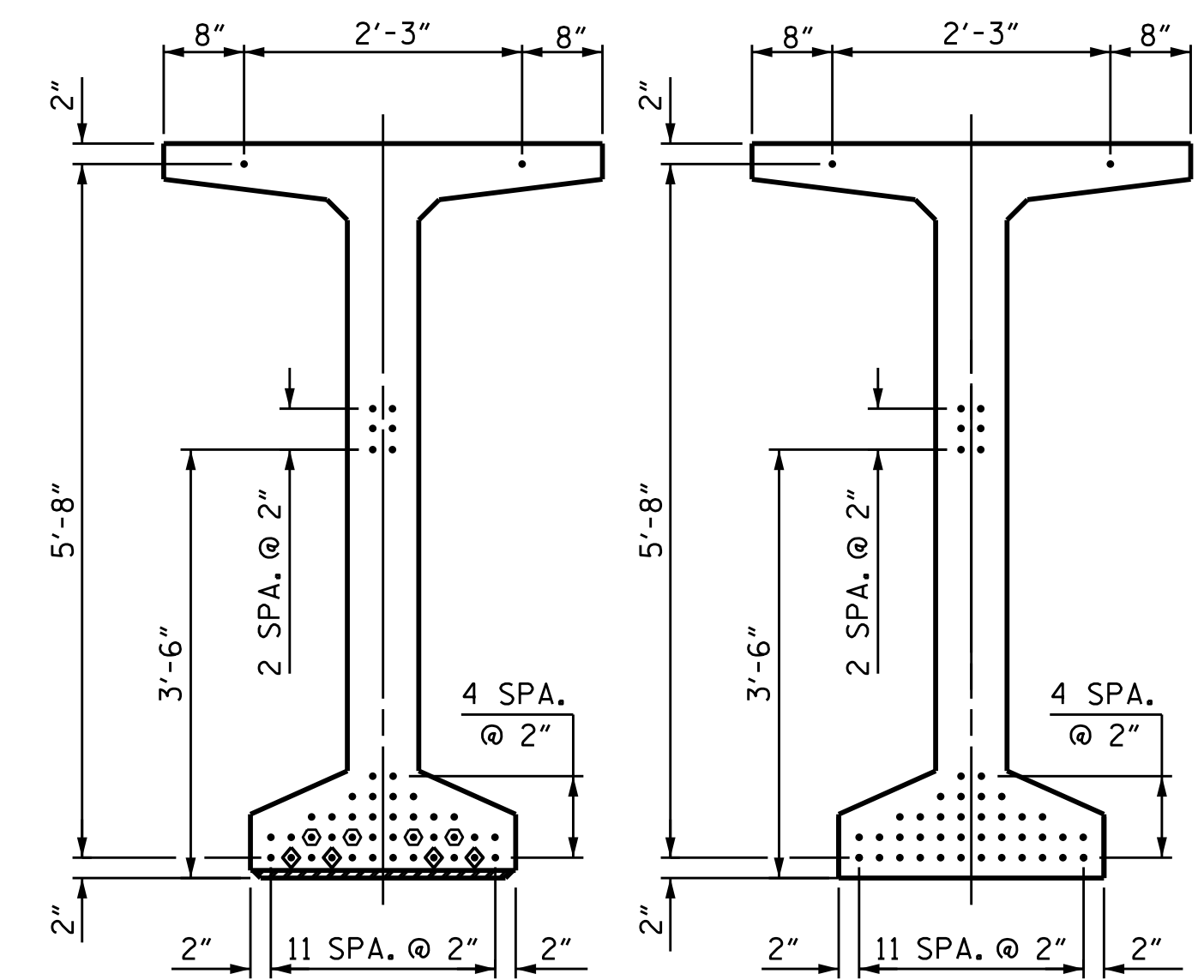
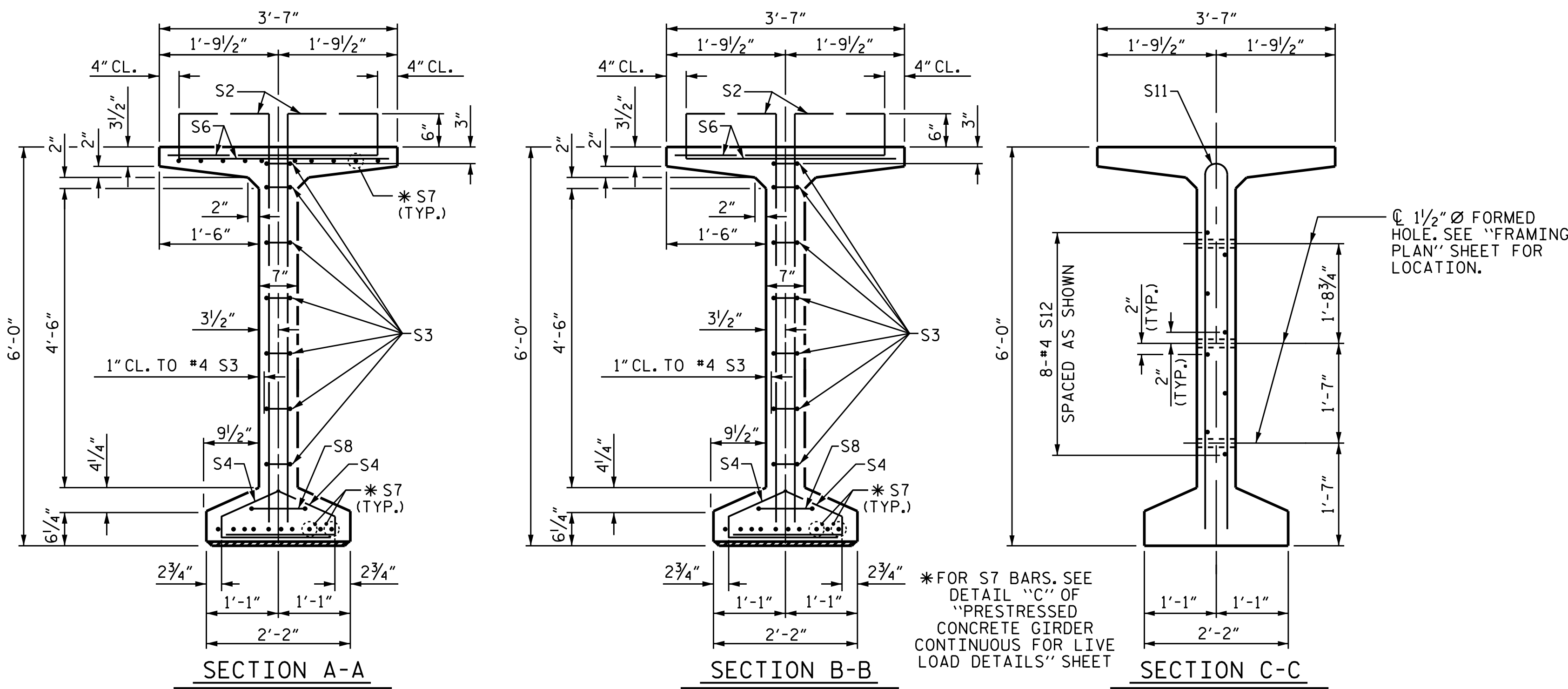

0.6" Ø L. R. GRADE 270 STRANDS

AREA (SQUARE INCHES)	ULTIMATE STRENGTH (LBS. PER STRAND)	APPLIED PRESTRESS (LBS. PER STRAND)
0.217	58,600	43,950

REINFORCING STEEL FOR ONE GDR

BAR	NUMBER	SIZE	TYPE	LENGTH	WEIGHT
S1	150	#4	1	6'-10"	685
S2	32	#5	1	6'-10"	228
S3	14	#4	2	8'-5"	79
S4	92	#4	3	3'-0"	184
S6	180	#5	4	4'-4"	814
* S7	30	#5	STR	3'-8"	115
S8	2	#5	2	9'-0"	19
S9	42	#5	STR	3'-3"	142
S10	2	#3	STR	1'-10"	1
S11	8	#5	5	11'-6"	96
S12	16	#4	STR	8'-0"	86
S13	1	#5	4	3'-8"	4

* NOTE: S7 BARS SHALL BE BENT BEFORE SHIPMENT. HEAT BENDING SHALL NOT BE ALLOWED.

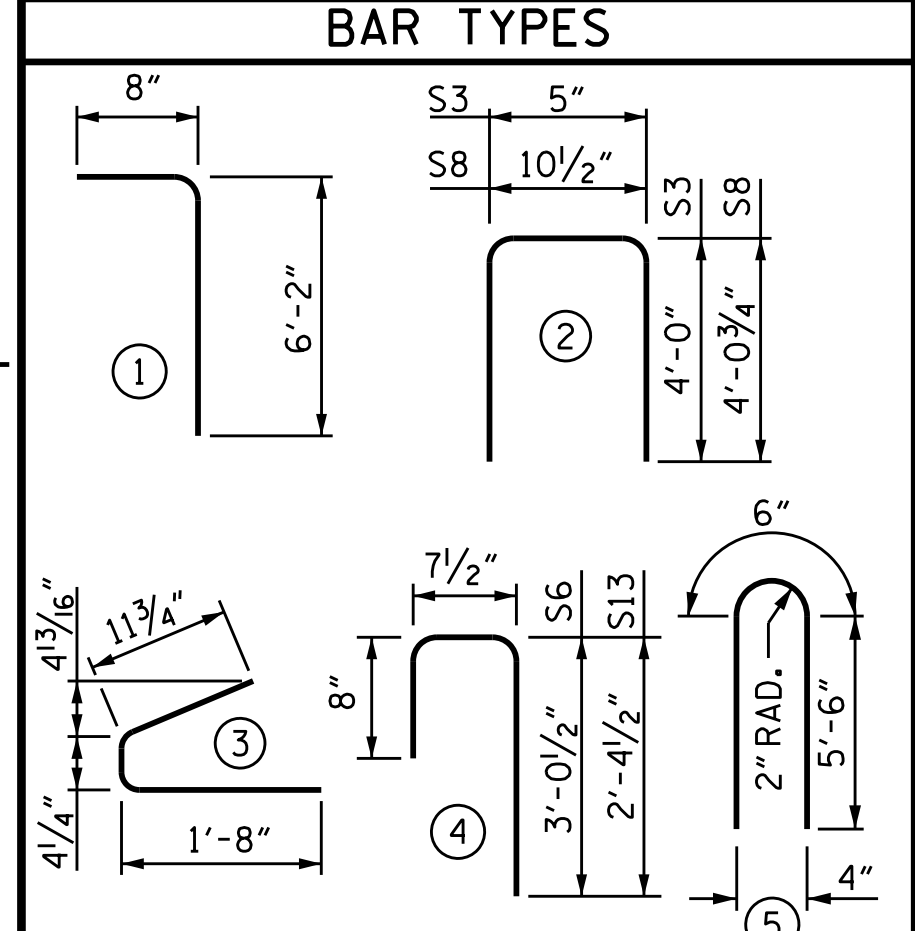

- DEBONDING LEGEND
- FULLY BONDED STRANDS
 - STRANDS DEBONDED FOR 10'-0" FROM END OF GIRDER
 - STRANDS DEBONDED FOR 12'-0" FROM END OF GIRDER

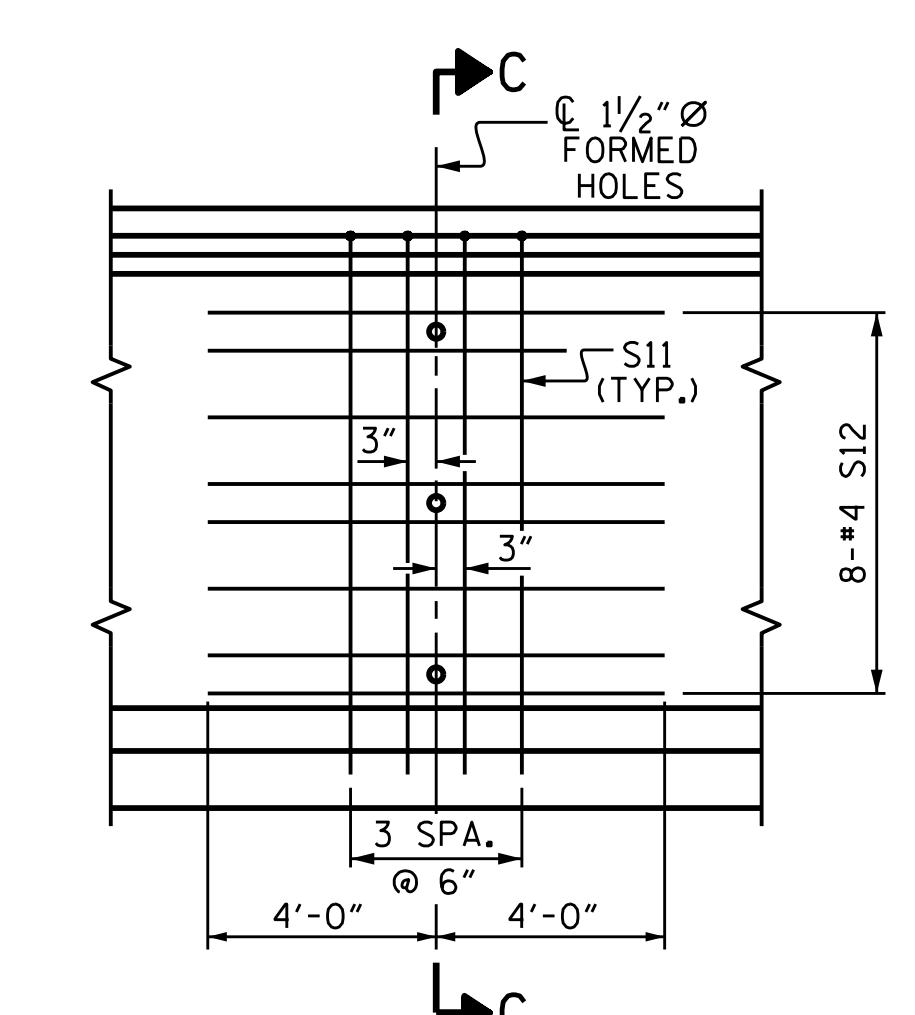

QUANTITIES FOR ONE GIRDER

REINFORCING STEEL	9,500 PSI CONCRETE	0.6" Ø L.R. STRANDS
LBS.	C.Y.	No.
2,453	22.9	46

GIRDERS REQUIRED

NUMBER	LENGTH	TOTAL LENGTH
4	107'-0 1/4"	428'-1"

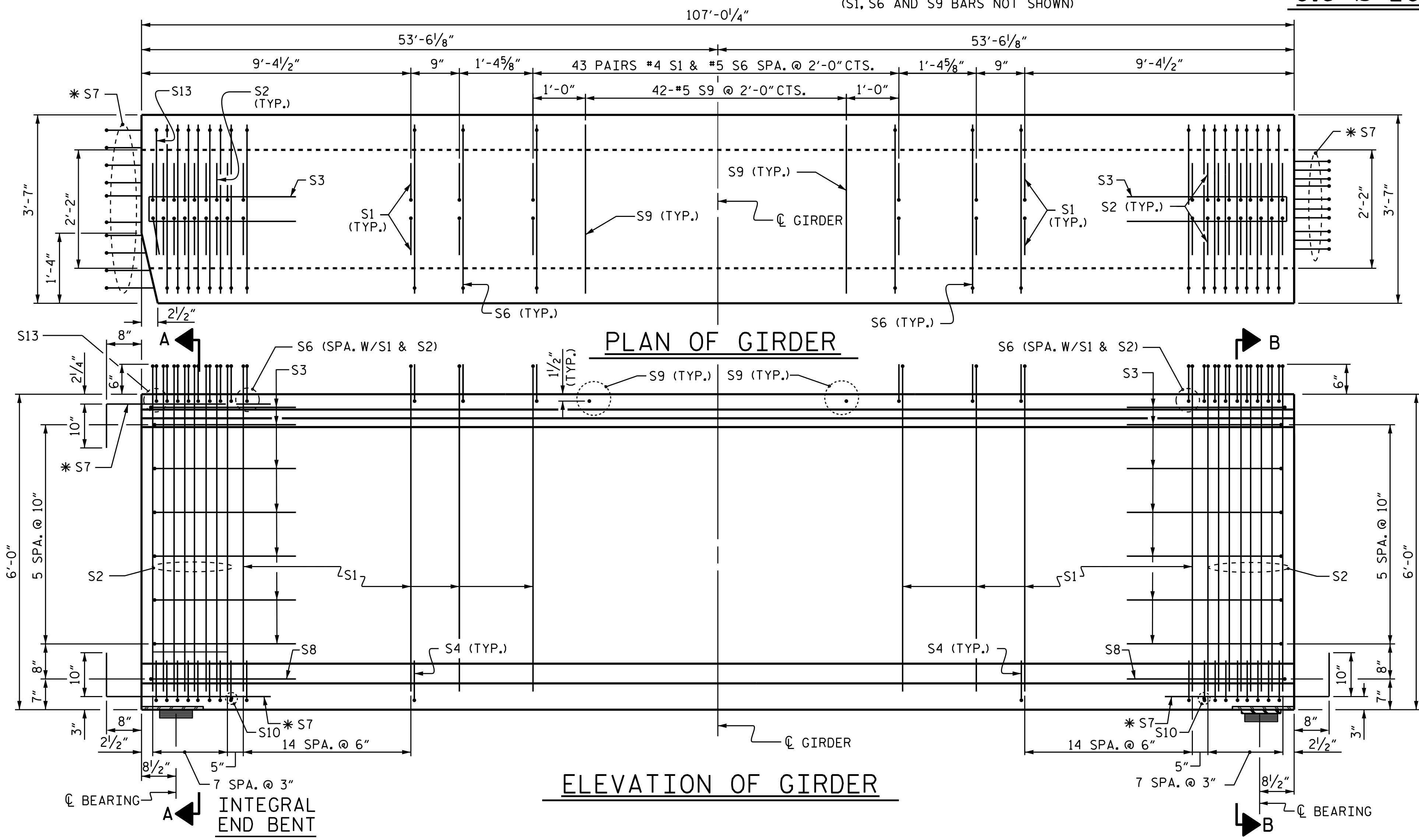

ASSEMBLED BY : N.D. AIUTO DATE : 1/25/16
 CHECKED BY : J.K. BOWLES DATE : 3/31/16

DRAWN BY : EEM 2/6/97 MAA/GM
 CHECKED BY : VAP 2/6/97 REV. 6/13 MAA/GM
 REV. 1/15 MAA/TMG

DESIGN ENGINEER OF RECORD:
 J.K. BOWLES DATE : 3/31/16

DOCUMENT NOT CONSIDERED FINAL UNLESS ALL SIGNATURES COMPLETED

PROJECT NO. U-2579C
 FORSYTH COUNTY
 STATION: 21+27.27 -Y2-

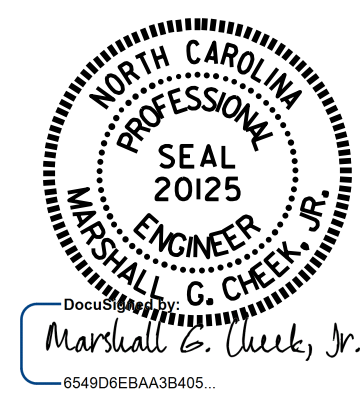

SHEET 1 OF 3

STATE OF NORTH CAROLINA
 DEPARTMENT OF TRANSPORTATION
 RALEIGH

STANDARD
 72" PRESTRESSED CONCRETE
 MODIFIED BULB TEE
 CONTINUOUS FOR LIVE LOAD
 SPAN A

REVISIONS						SHEET NO.
NO.	BY:	DATE:	NO.	BY:	DATE:	S2-10
1			3			TOTAL SHEETS 30
2			4			

STR. #2 STD. NO. PCG8

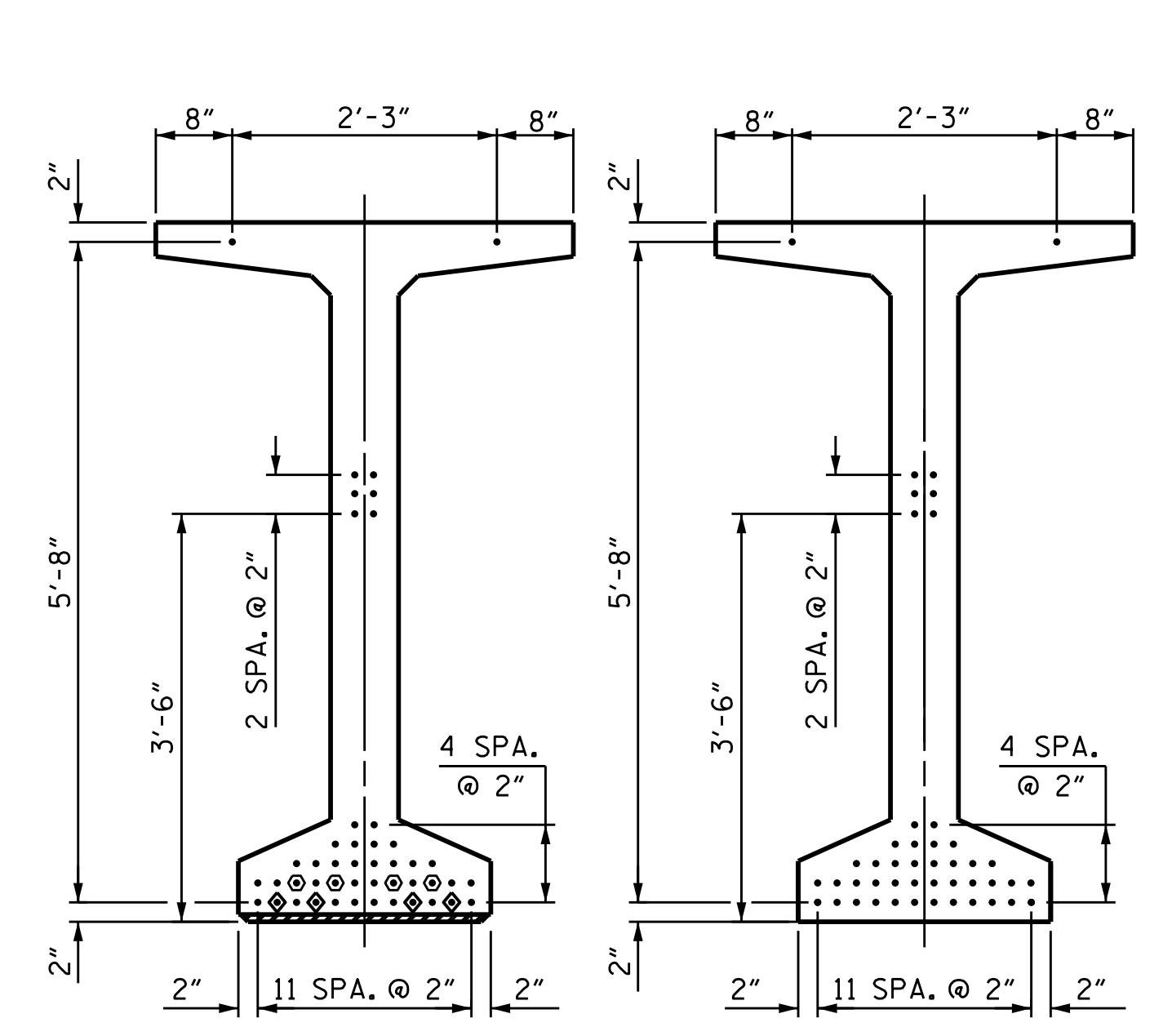
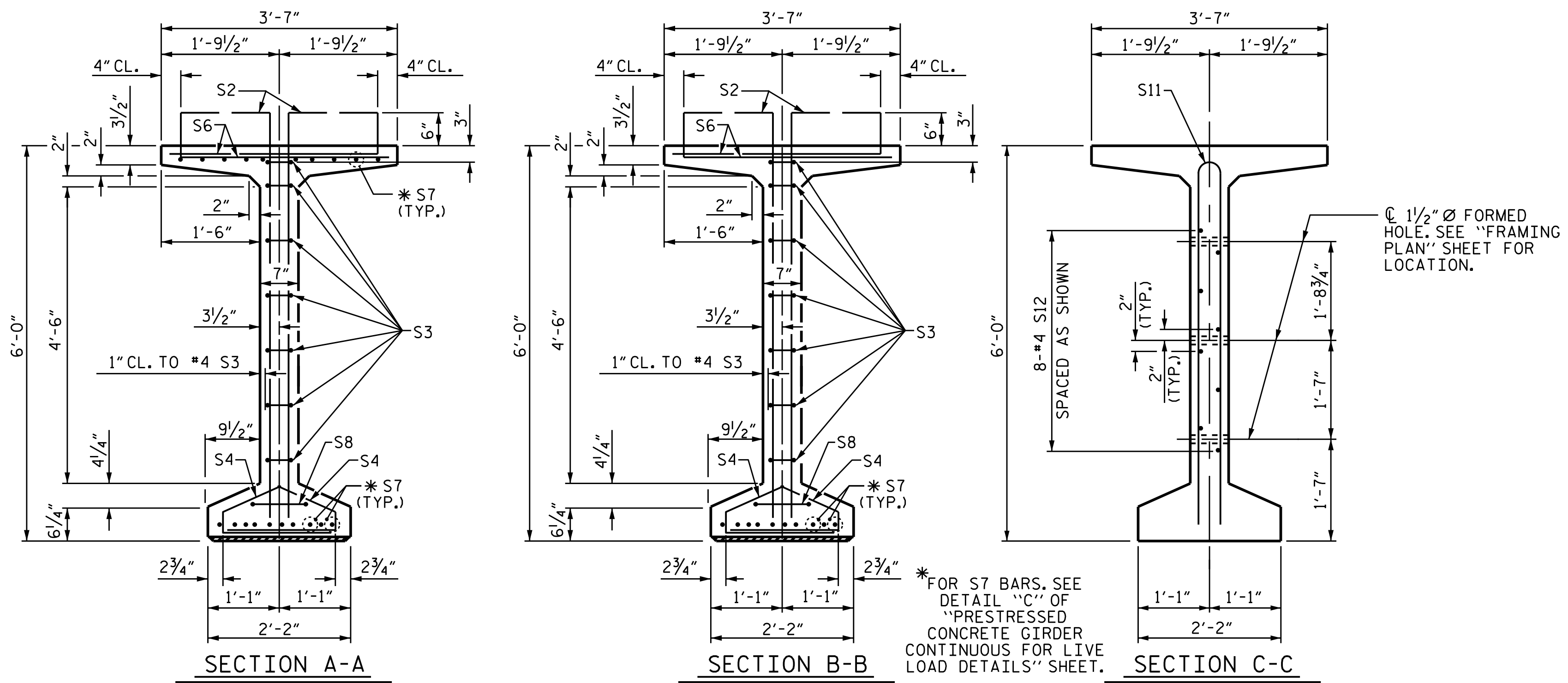

0.6" Ø L. R. GRADE 270 STRANDS

AREA (SQUARE INCHES)	ULTIMATE STRENGTH (LBS. PER STRAND)	APPLIED PRESTRESS (LBS. PER STRAND)
0.217	58,600	43,950

REINFORCING STEEL FOR ONE GDR

BAR	NUMBER	SIZE	TYPE	LENGTH	WEIGHT
S1	156	#4	1	6'-10"	712
S2	32	#5	1	6'-10"	228
S3	14	#4	2	8'-5"	79
S4	92	#4	3	3'-0"	184
S6	186	#5	4	4'-4"	841
* S7	30	#5	STR	3'-8"	115
S8	2	#5	2	9'-0"	19
S9	43	#5	STR	3'-3"	146
S10	2	#3	STR	1'-10"	1
S11	8	#5	5	11'-6"	96
S12	16	#4	STR	8'-8"	86
S13	1	#5	4	3'-8"	4

* NOTE: S7 BARS SHALL BE BENT BEFORE SHIPMENT. HEAT BENDING SHALL NOT BE ALLOWED.

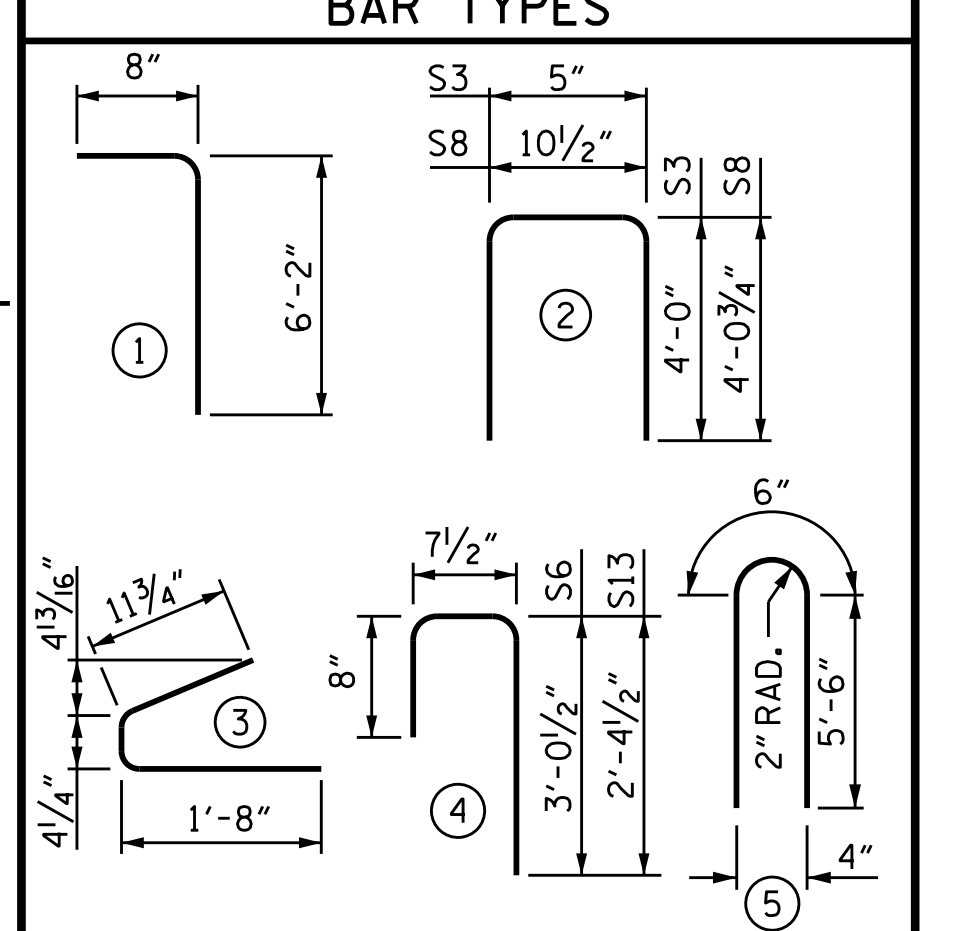

0.6" Ø LOW RELAXATION STRAND LAYOUT

- DEBONDING LEGEND**
- FULLY BONDED STRANDS
 - ◆ STRANDS DEBONDED FOR 10'-0" FROM END OF GIRDER
 - ⊙ STRANDS DEBONDED FOR 12'-0" FROM END OF GIRDER

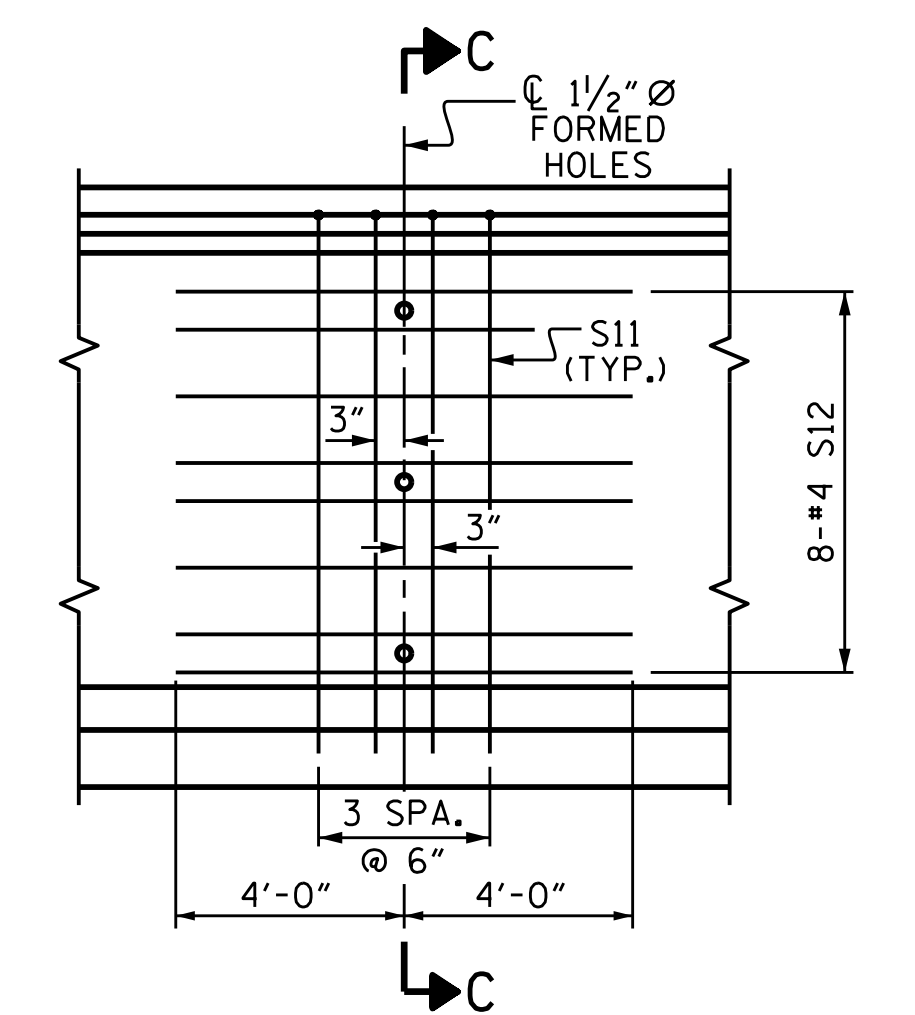

PARTIAL ELEVATION
SHOWING INTERMEDIATE STEEL DIAPHRAGM REINFORCING STEEL FOR SPAN B GIRDERS. (2 LOCATIONS PER GIRDER)

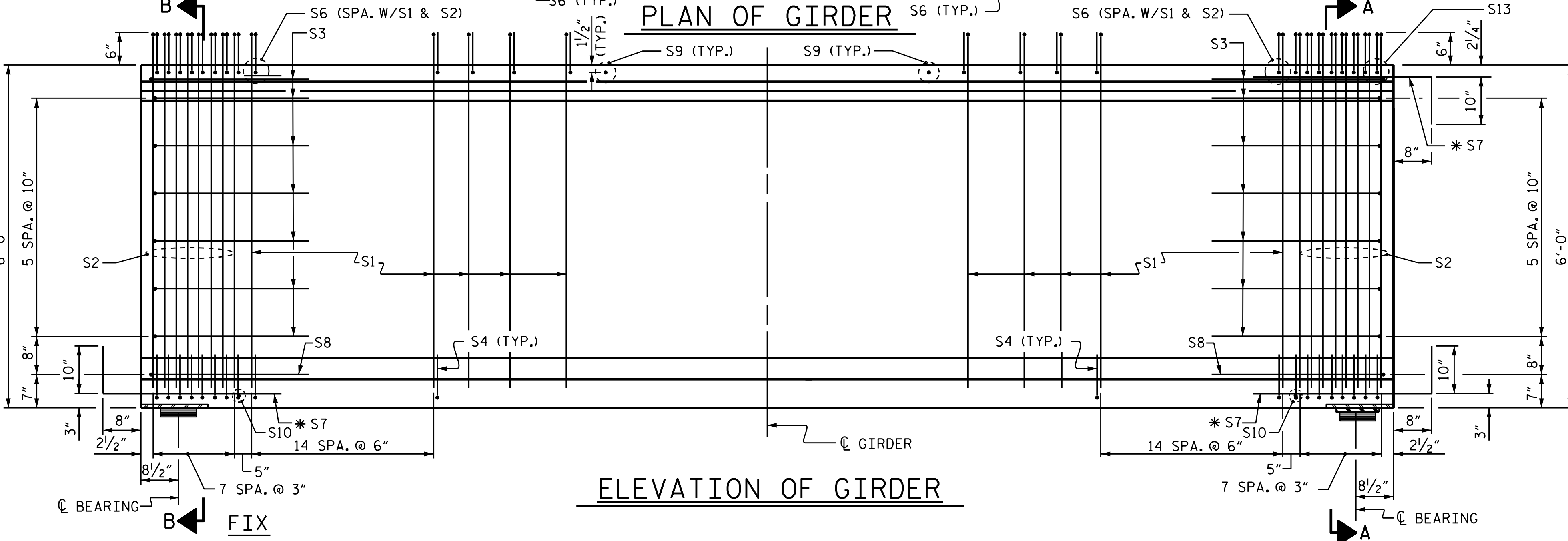
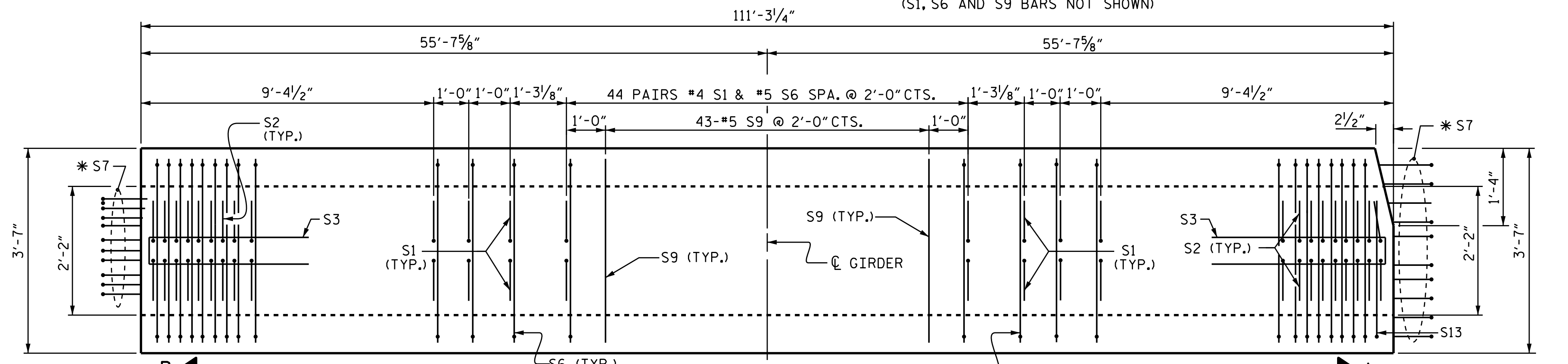

QUANTITIES FOR ONE GIRDER

REINFORCING STEEL	9,500 PSI CONCRETE	0.6" Ø L.R. STRANDS
LBS.	C.Y.	No.
2,511	23.8	46

GIRDERS REQUIRED

NUMBER	LENGTH	TOTAL LENGTH
4	111'-3 1/4"	445'-1"

PROJECT NO. U-2579C
 FORSYTH COUNTY
 STATION: 21+27.27 -Y2-

SHEET 2 OF 3

STATE OF NORTH CAROLINA
 DEPARTMENT OF TRANSPORTATION
 RALEIGH

STANDARD
 72" PRESTRESSED CONCRETE
 MODIFIED BULB TEE
 CONTINUOUS FOR LIVE LOAD
 SPAN B

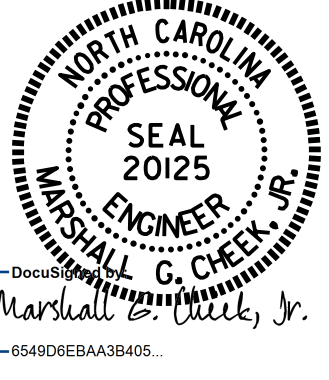

ASSEMBLED BY : N.D. AIUTO	DATE : 1/25/16
CHECKED BY : J.K. BOWLES	DATE : 3/31/16
DRAWN BY : EEM 2/6/97	REV. 10/1/11
CHECKED BY : VAP 2/6/97	REV. 6/13
	REV. 1/15
DESIGN ENGINEER OF RECORD:	MAA/GM
J.K. BOWLES	MAA/GM
DATE : 3/31/16	MAA/TMG

DOCUMENT NOT CONSIDERED FINAL UNLESS ALL SIGNATURES COMPLETED

REVISIONS						SHEET NO.
NO.	BY:	DATE:	NO.	BY:	DATE:	S2-11
1			3			TOTAL SHEETS 30
2			4			

STR. #2 STD. NO. PCGB

26-JUL-2017 15:06 R:\Structural\402_021_U2579C_SMU_02_011_330701.dgn mcheek

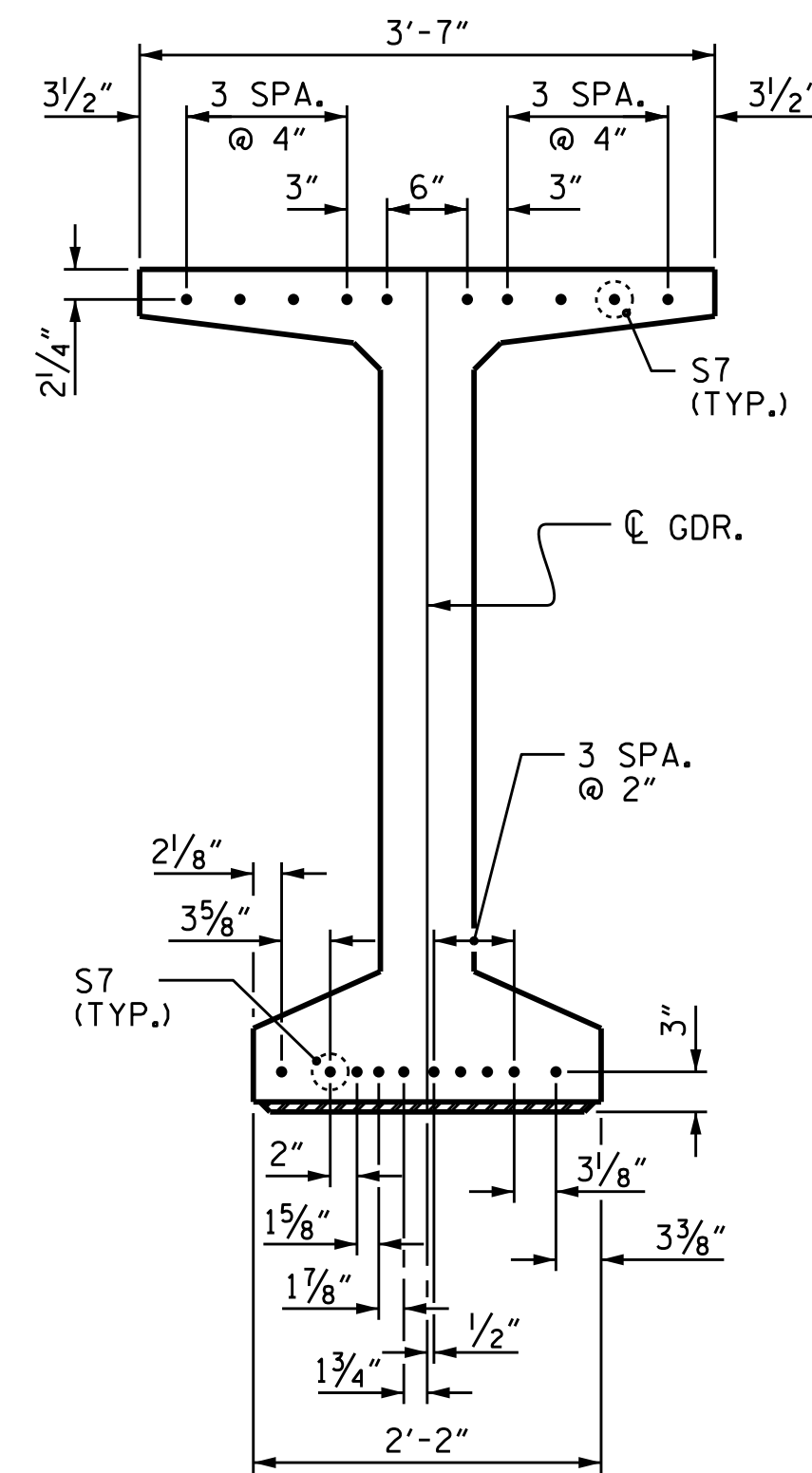

DETAIL "C"

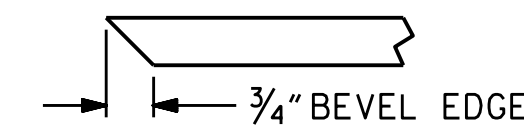
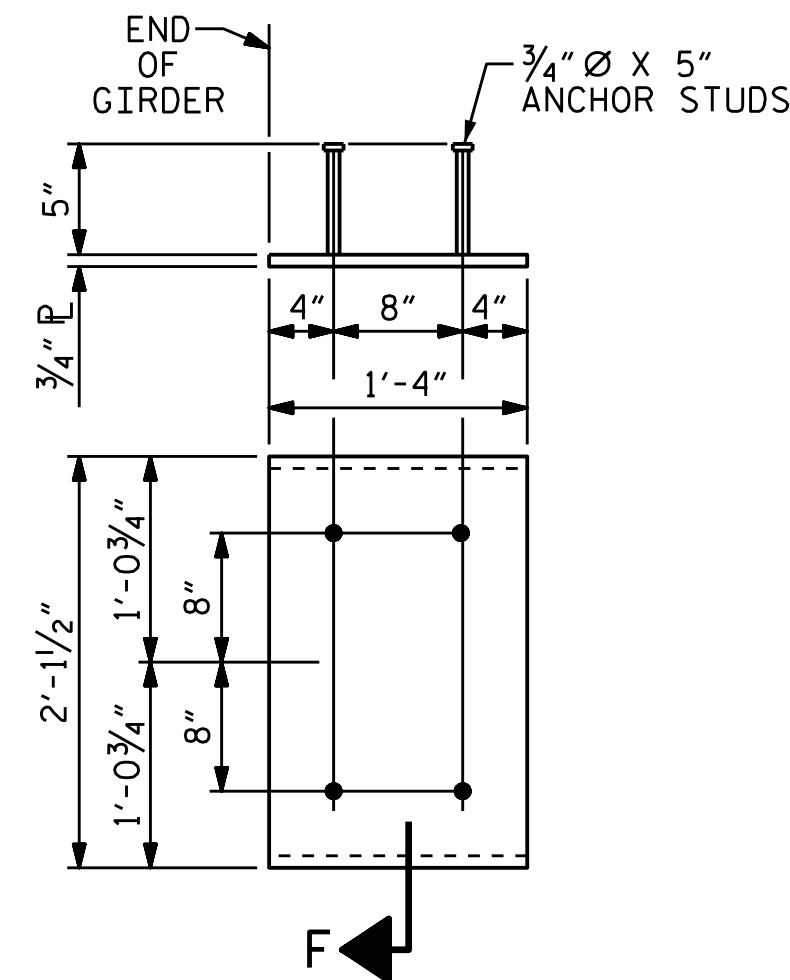

SECTION "F"
(SEE NOTES)

EMBEDDED PLATE "B-1" DETAILS
FOR 72" MODIFIED BULB TEES
(2 REQ'D PER GIRDER)

NOTES

ALL PRESTRESSING STRANDS SHALL BE 7-WIRE LOW-RELAXATION GRADE 270 STRANDS AND SHALL CONFORM TO AASHTO M203 EXCEPT FOR SAMPLING REQUIREMENTS WHICH SHALL BE IN ACCORDANCE WITH THE STANDARD SPECIFICATIONS.

ALL REINFORCING STEEL SHALL BE GRADE 60.

EMBEDDED PLATE "B-1" SHALL BE GALVANIZED IN ACCORDANCE WITH THE STANDARD SPECIFICATIONS.

ANCHOR STUDS SHALL CONFORM TO AASHTO M169 GRADES 1010 THROUGH 1020 OR APPROVED EQUAL, AND SHALL MEET THE TYPE "B" REQUIREMENTS OF SUBSECTION 7.3 OF THE ANSI/AASHTO/AWS D1.5 BRIDGE WELDING CODE.

AT ENDS OF GIRDERS TO BE EMBEDDED IN CONCRETE DIAPHRAGMS OR END WALLS, PRESTRESSING STRANDS MAY EXTEND A MAXIMUM OF 2" BEYOND THE GIRDER ENDS. OTHERWISE, PRESTRESSING STRANDS SHALL BE CUT FLUSH WITH THE GIRDER ENDS.

THE TRANSFER OF LOAD FROM THE ANCHORAGES TO THE GIRDER SHALL BE DONE WHEN CONCRETE HAS REACHED A COMPRESSIVE STRENGTH OF NOT LESS THAN 7,600 PSI.

DEPENDING ON THE TYPE OF SYSTEM USED TO SUPPORT THE DECK SLAB FORMS, PRESET ANCHORS MAY BE NECESSARY IN THE PRESTRESSED CONCRETE GIRDER.

THE TOP SURFACE OF THE GIRDER, EXCLUDING THE OUTSIDE 4", SHALL BE RAKED TO A DEPTH OF 1/4".

A 2" x 2" CHAMFER IS ALLOWED AT THE INTERSECTION OF THE WEB AND THE BOTTOM FLANGE OF THE 72" MODIFIED BULB TEES ONLY.

FOR EMBEDDED CLIPS FOR PRESTRESSED CONCRETE GIRDERS, SEE SPECIAL PROVISIONS.

DEAD LOAD DEFLECTION TABLE FOR GIRDERS																						
0.6" Ø LOW RELAXATION	SPAN A																					
	GIRDERS 1 THROUGH 4																					
	TWENTIETH POINTS	CL BRG.	0.05	0.10	0.15	0.20	0.25	0.30	0.35	0.40	0.45	0.50	0.55	0.60	0.65	0.70	0.75	0.80	0.85	0.90	0.95	CL BRG.
CAMBER (GIRDER ALONE IN PLACE)	↑	0.000	0.039	0.078	0.114	0.147	0.176	0.201	0.221	0.235	0.244	0.247	0.244	0.235	0.221	0.201	0.176	0.147	0.114	0.078	0.039	0.000
* DEFLECTION DUE TO SUPERIMPOSED D.L.	↓	0.000	0.017	0.036	0.052	0.065	0.077	0.090	0.097	0.105	0.107	0.110	0.107	0.105	0.097	0.090	0.077	0.065	0.052	0.036	0.017	0.000
FINAL CAMBER	↑	0	1/4"	1/2"	3/4"	1"	1 1/16"	1 1/16"	1 1/2"	1 1/16"	1 5/8"	1 5/8"	1 5/8"	1 5/8"	1 1/2"	1 5/16"	1 3/8"	1"	3/4"	1/2"	1/4"	0

ALL VALUES ARE SHOWN IN FEET (DECIMAL FORM), EXCEPT "FINAL CAMBER", WHICH IS GIVEN IN INCHES (FRACTION FORM).
* INCLUDES FUTURE WEARING SURFACE

DEAD LOAD DEFLECTION TABLE FOR GIRDERS																						
0.6" Ø LOW RELAXATION	SPAN B																					
	GIRDERS 1 THROUGH 4																					
	TWENTIETH POINTS	CL BRG.	0.05	0.10	0.15	0.20	0.25	0.30	0.35	0.40	0.45	0.50	0.55	0.60	0.65	0.70	0.75	0.80	0.85	0.90	0.95	CL BRG.
CAMBER (GIRDER ALONE IN PLACE)	↑	0.000	0.041	0.081	0.119	0.154	0.185	0.211	0.231	0.246	0.256	0.259	0.256	0.246	0.231	0.211	0.185	0.154	0.119	0.081	0.041	0.000
* DEFLECTION DUE TO SUPERIMPOSED D.L.	↓	0.000	0.021	0.042	0.061	0.080	0.095	0.109	0.119	0.128	0.131	0.135	0.131	0.128	0.119	0.109	0.095	0.080	0.061	0.042	0.021	0.000
FINAL CAMBER	↑	0	1/4"	7/16"	1 1/16"	7/8"	1 1/16"	1 1/4"	1 3/8"	1 7/16"	1 1/2"	1 1/2"	1 1/2"	1 1/16"	1 3/8"	1 1/4"	1 1/16"	7/8"	1 1/16"	7/16"	1/4"	0

ALL VALUES ARE SHOWN IN FEET (DECIMAL FORM), EXCEPT "FINAL CAMBER", WHICH IS GIVEN IN INCHES (FRACTION FORM).
* INCLUDES FUTURE WEARING SURFACE

PROJECT NO. U-2579C
FORSYTH COUNTY
 STATION: 21+27.27 -Y2-

SHEET 3 OF 3

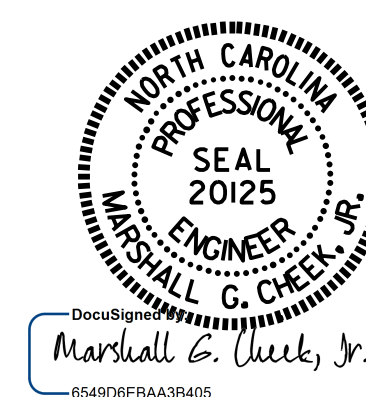

STATE OF NORTH CAROLINA
 DEPARTMENT OF TRANSPORTATION
 RALEIGH
 STANDARD
 PRESTRESSED CONCRETE GIRDER
 CONTINUOUS FOR LIVE LOAD
 DETAILS

ASSEMBLED BY : N.D. AIUTO	DATE : 1/26/16
CHECKED BY : J.K. BOWLES	DATE : 3/31/16
DRAWN BY : ELR 11/91	REV. 10/1/11 MAA/GM
CHECKED BY : GRP 11/91	REV. 1/15 MAA/TMG
	REV. 2/15 MAA/TMG

DOCUMENT NOT CONSIDERED
 FINAL UNLESS ALL
 SIGNATURES COMPLETED

REVISIONS						SHEET NO.	
NO.	BY:	DATE:	NO.	BY:	DATE:	S2-12	
1			3			TOTAL SHEETS 30	
2			4				

STRUCTURAL STEEL NOTES

ALL INTERMEDIATE DIAPHRAGM STEEL AND CONNECTOR PLATES SHALL BE AASHTO M270 GRADE 50 OR APPROVED EQUAL.

TENSION ON THE ASTM A325 BOLTS THROUGH THE ANGLE MEMBER SHALL BE CALIBRATED USING DIRECT TENSION INDICATOR WASHERS IN ACCORDANCE WITH THE STANDARD SPECIFICATIONS.

TENSION ON THE ASTM A449 BOLTS THROUGH THE GIRDER WEB SHALL BE SNUG TIGHTENED FOLLOWED BY AN ADDITIONAL 1/4 TURN.

THE PLATES, BENT PLATES, AND ANGLES SHALL BE GALVANIZED OR METALLIZED IN ACCORDANCE WITH THE STANDARD SPECIFICATIONS. FOR THERMAL SPRAYED COATINGS (METALLIZATION), SEE SPECIAL PROVISIONS.

FOR METALLIZATION, APPLY AN 8 MIL THICK 99.99 PERCENT ZINC (W-Zn-1) THERMAL SPRAYED COATING WITH A 0.5 MIL THICK SEAL COAT TO ALL STEEL DIAPHRAGM SURFACES IN ACCORDANCE WITH THE THERMAL SPRAYED COATINGS SPECIAL PROVISION AND SECTION 442 OF THE STANDARD SPECIFICATIONS.

GALVANIZE THE HIGH STRENGTH BOLTS, NUTS, WASHERS AND DIRECT TENSION INDICATORS IN ACCORDANCE WITH THE STANDARD SPECIFICATIONS.

USE AN ASTM F436 HARDENED WASHER WITH STANDARD AND SLOTTED HOLES UNDER EACH BOLT HEAD AND NUT.

FOR BOLTS THROUGH THE GIRDER WEB, PROVIDE SUFFICIENT LENGTH OF THREADS ON ALL BOLTS TO ACCOMMODATE WASHERS AND THE THICKNESS OF CONNECTING MEMBER PLUS AT LEAST 1/4" PROJECTION BEYOND THE NUT.

INTERMEDIATE DIAPHRAGM ASSEMBLY SHALL COMPLY WITH SECTION 1072 OF THE STANDARD SPECIFICATIONS.

SUBMIT TWO SETS OF WORKING DRAWINGS FOR THE INTERMEDIATE DIAPHRAGM ASSEMBLY FOR REVIEW, COMMENTS AND ACCEPTANCE. AFTER REVIEW, COMMENTS, AND ACCEPTANCE, SUBMIT SEVEN SETS FOR DISTRIBUTION.

IN THE EXTERIOR BAYS, PLACE TEMPORARY STRUTS BETWEEN PRESTRESSED GIRDERS ADJACENT TO THE STEEL DIAPHRAGMS. STRUTS SHALL REMAIN IN PLACE 3 DAYS AFTER CONCRETE IS PLACED.

THE COST OF THE STEEL DIAPHRAGMS AND ASSEMBLIES SHALL BE INCLUDED IN THE UNIT PRICE BID FOR MODIFIED 72" PRESTRESSED CONCRETE GIRDERS.

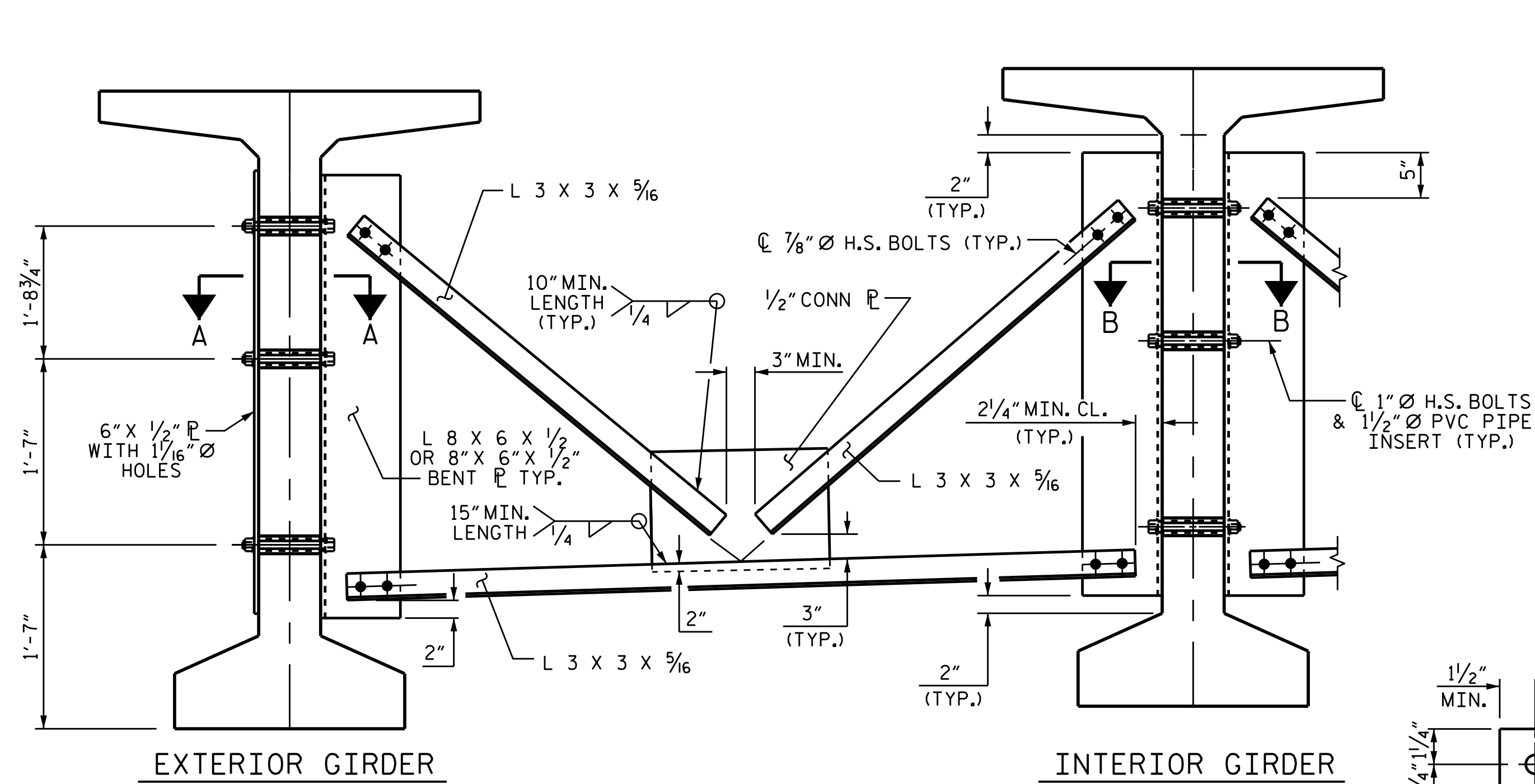

PART SECTION AT INTERMEDIATE DIAPHRAGM

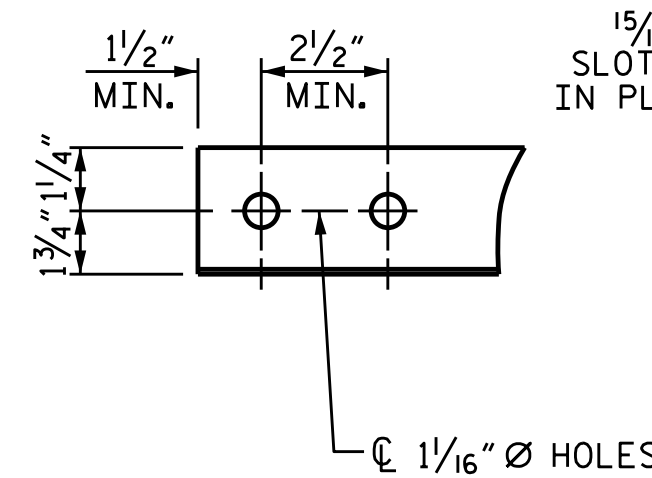

ANGLE END
(L 3 x 3 x 5/16)

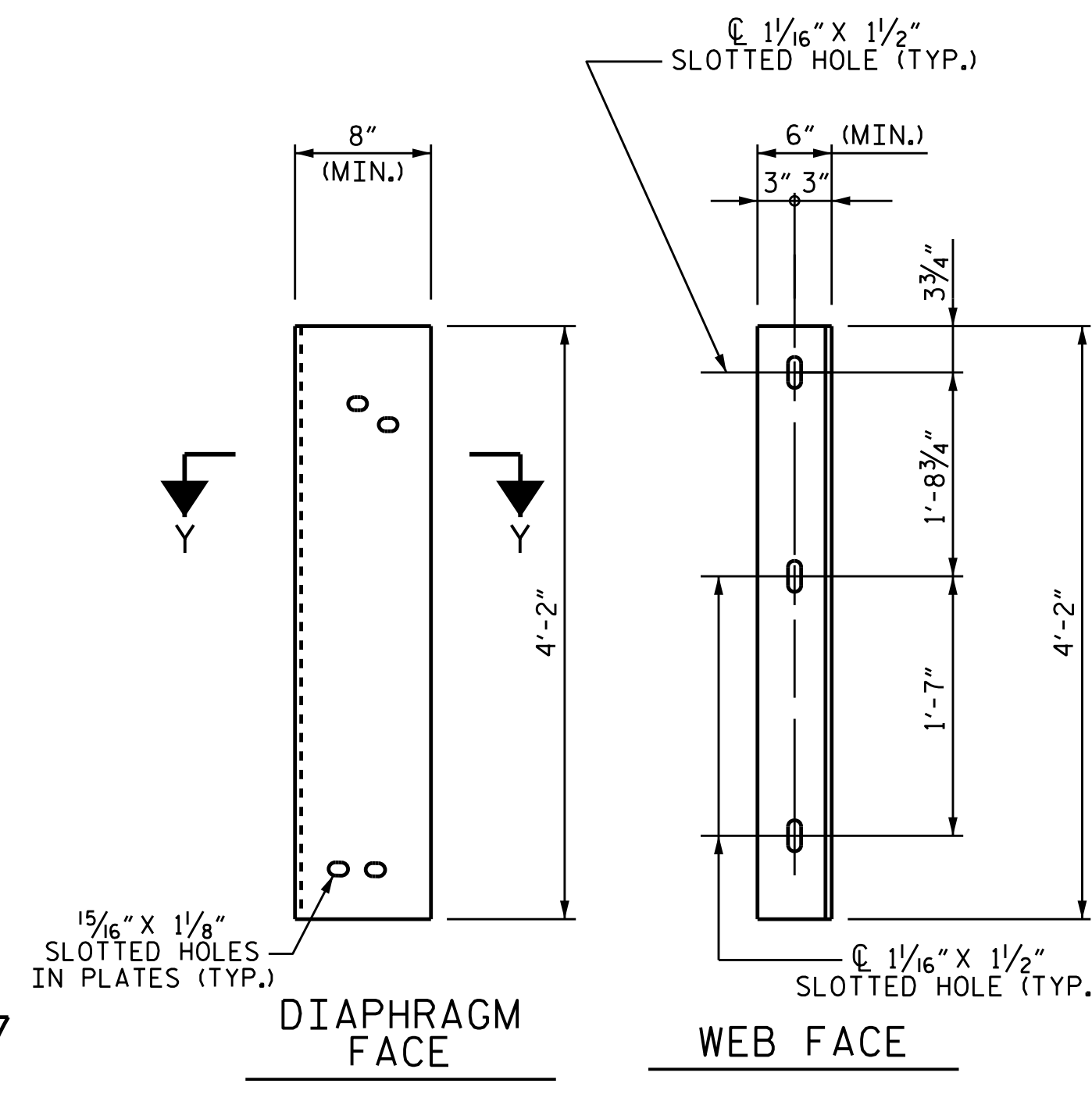

CONNECTOR PLATE DETAIL

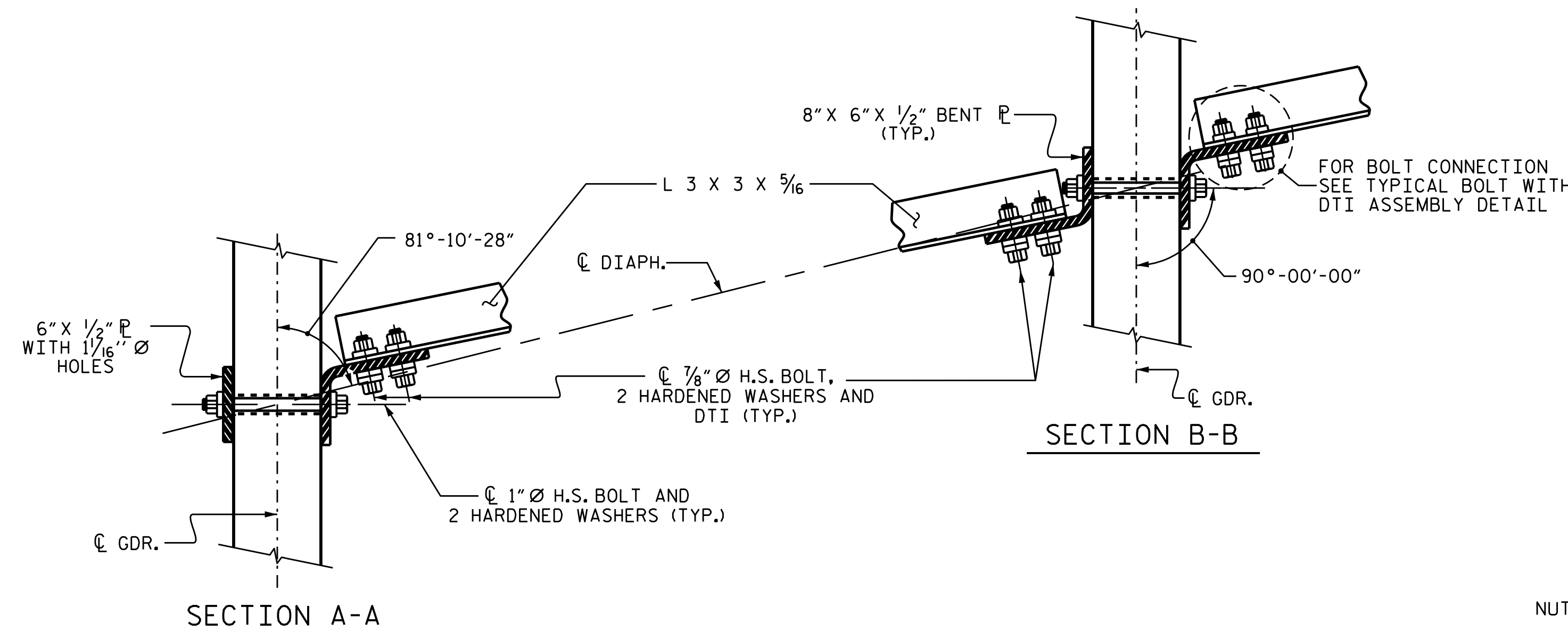

CONNECTION DETAILS

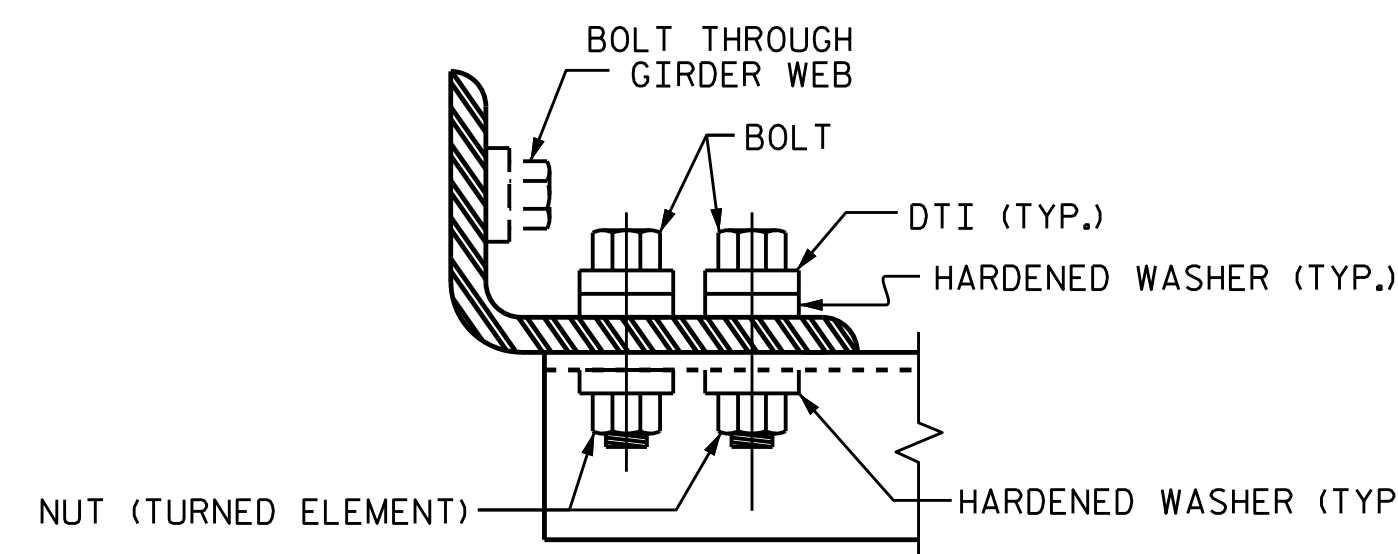

BOLT WITH DTI ASSEMBLY DETAIL

PROJECT NO. U-2579C
FORSYTH COUNTY
 STATION: 21+27.27 -Y2-

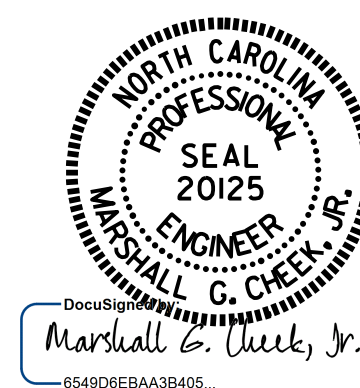

7/27/2017

STATE OF NORTH CAROLINA
 DEPARTMENT OF TRANSPORTATION
 RALEIGH
 STANDARD
 INTERMEDIATE
 STEEL DIAPHRAGMS FOR 72"
 MODIFIED BULB TEE
 PRESTRESSED CONCRETE
 GIRDERS

ASSEMBLED BY : N.D'AIUTO	DATE : 1/26/16
CHECKED BY : J.K.BOWLES	DATE : 3/31/16
DRAWN BY : RWW 11/09	ADDED 11/23/09R
CHECKED BY : GM 11/09	REV. 10/1/11

26-JUL-2017 15:06
 R:\Structures\FINAL PLANS\402.025.U2579C.SMU.SD.013.330701.dgn
 mcheek

DOCUMENT NOT CONSIDERED
 FINAL UNLESS ALL
 SIGNATURES COMPLETED

REVISIONS						SHEET NO.	
NO.	BY:	DATE:	NO.	BY:	DATE:	S2-13	
1			3			TOTAL SHEETS	
2			4			30	

STR. #2 STD. NO. PCG11

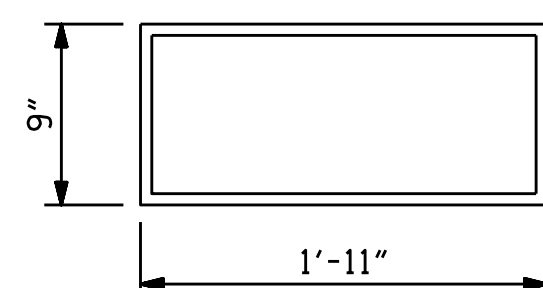
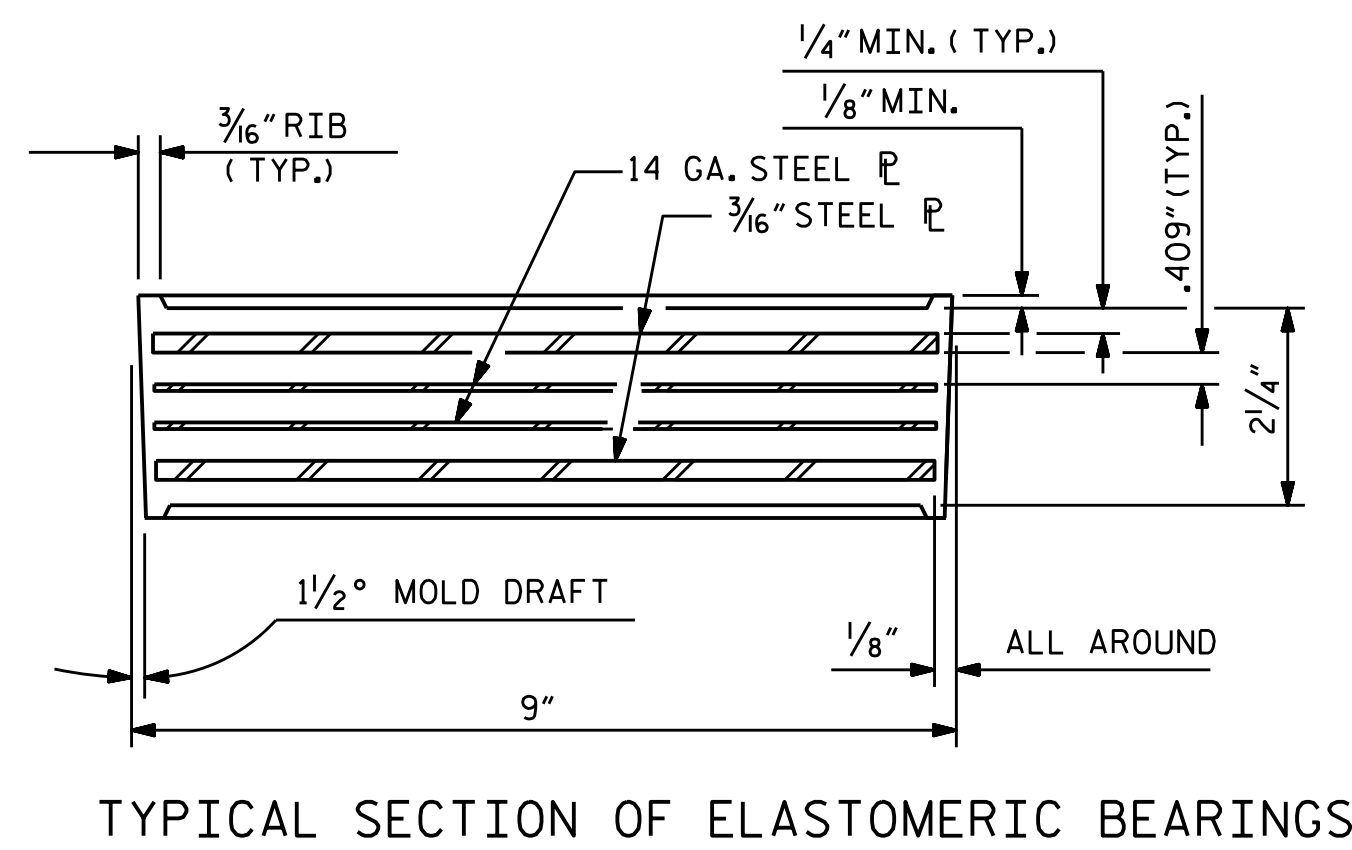
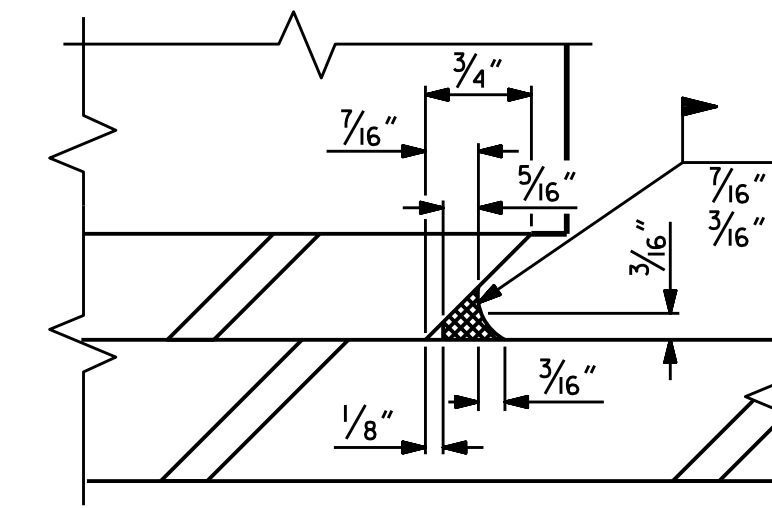
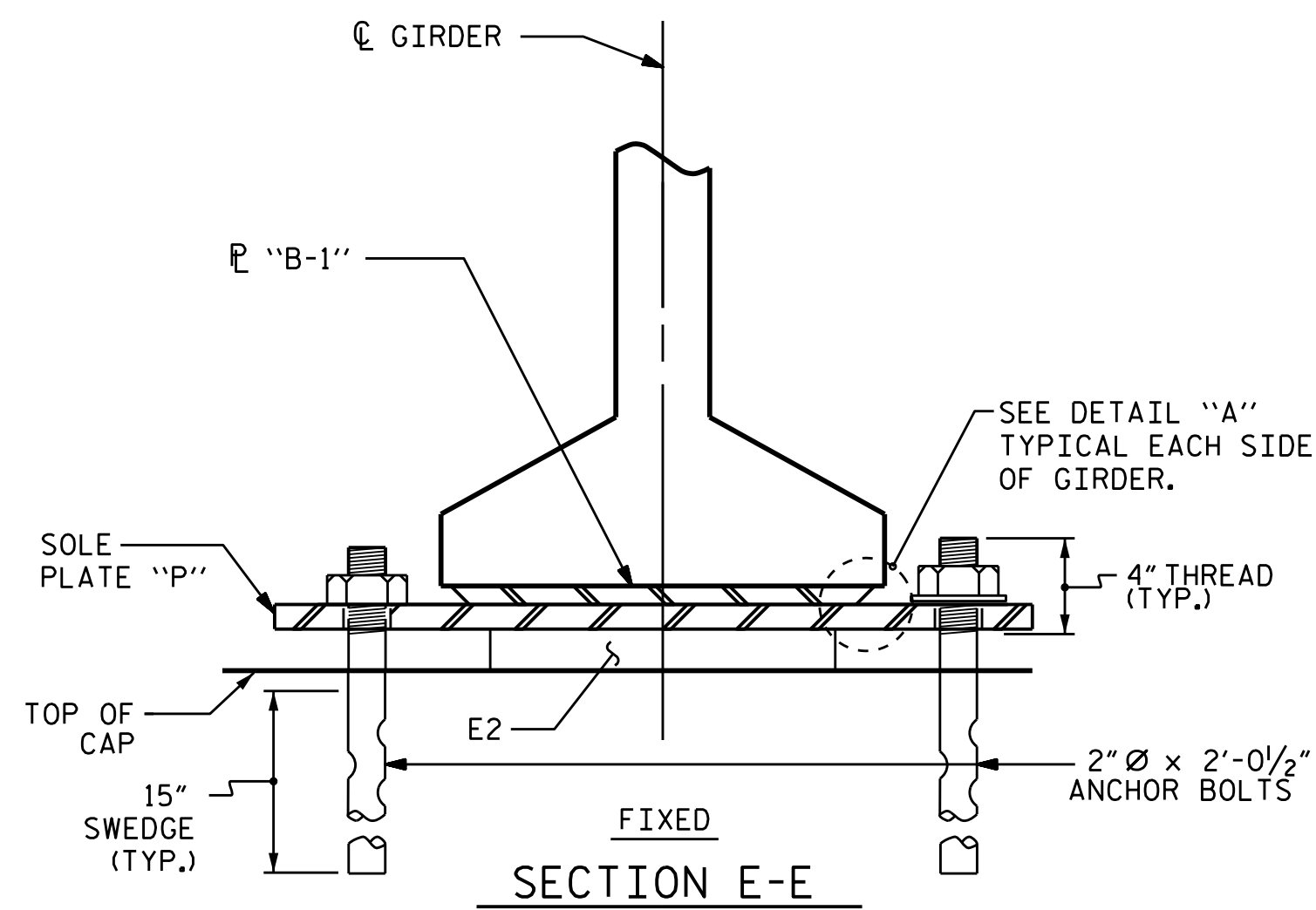
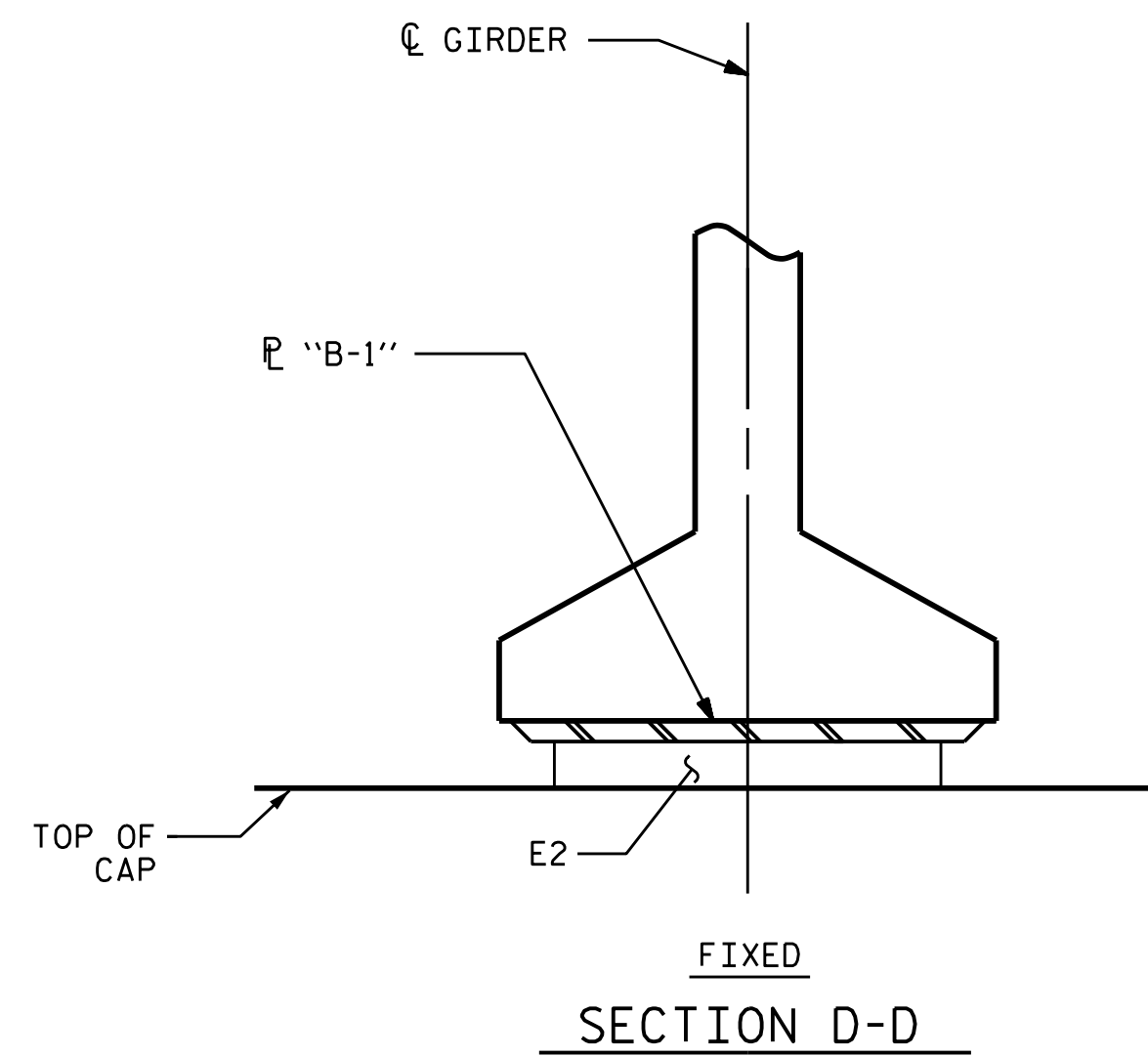

E1 (16 REQ'D)
PLAN VIEW OF ELASTOMERIC BEARING

TYPE V

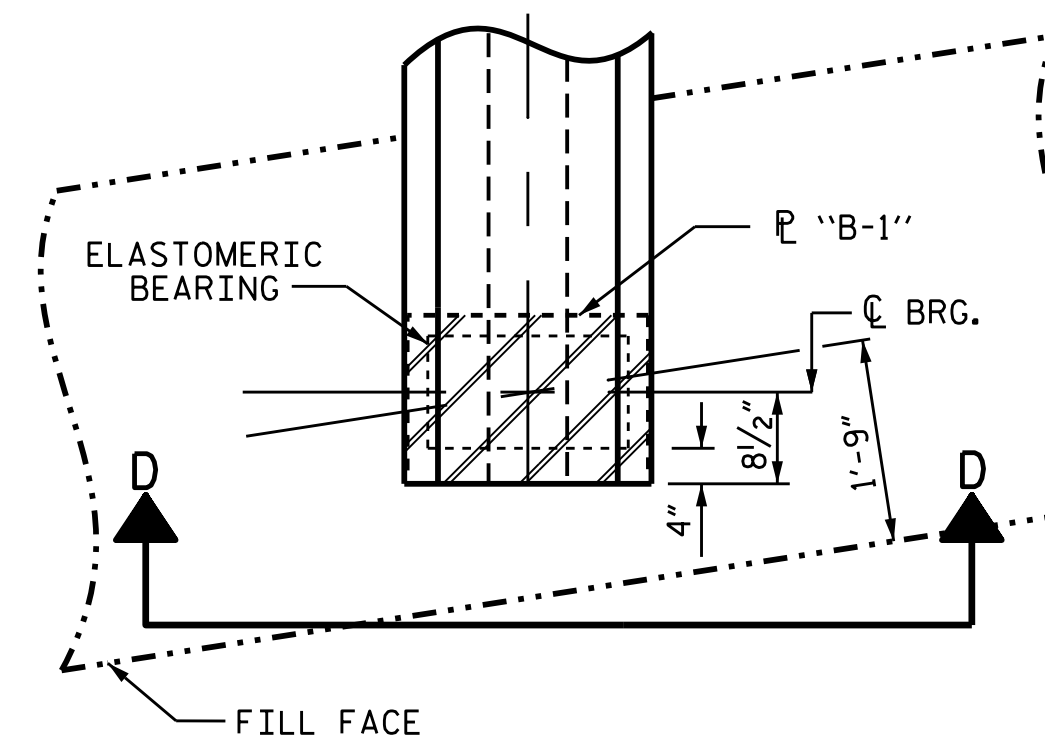

PLAN VIEW AT INTEGRAL END BENT

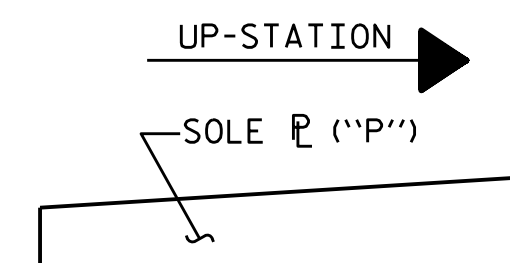

SOLE P PLACEMENT DETAIL

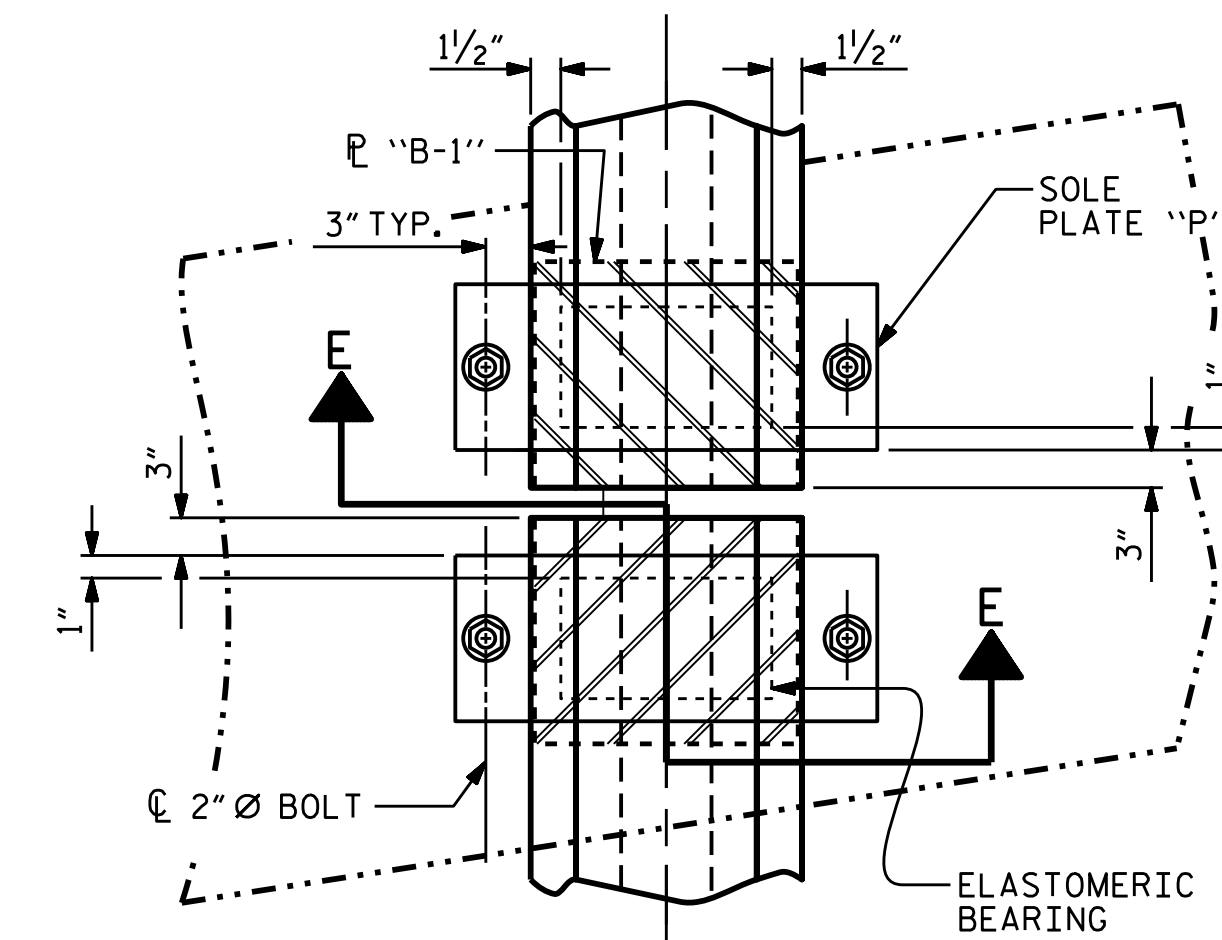

TYPICAL HALF-PLAN
(SHOWING CONTINUOUS BENT)

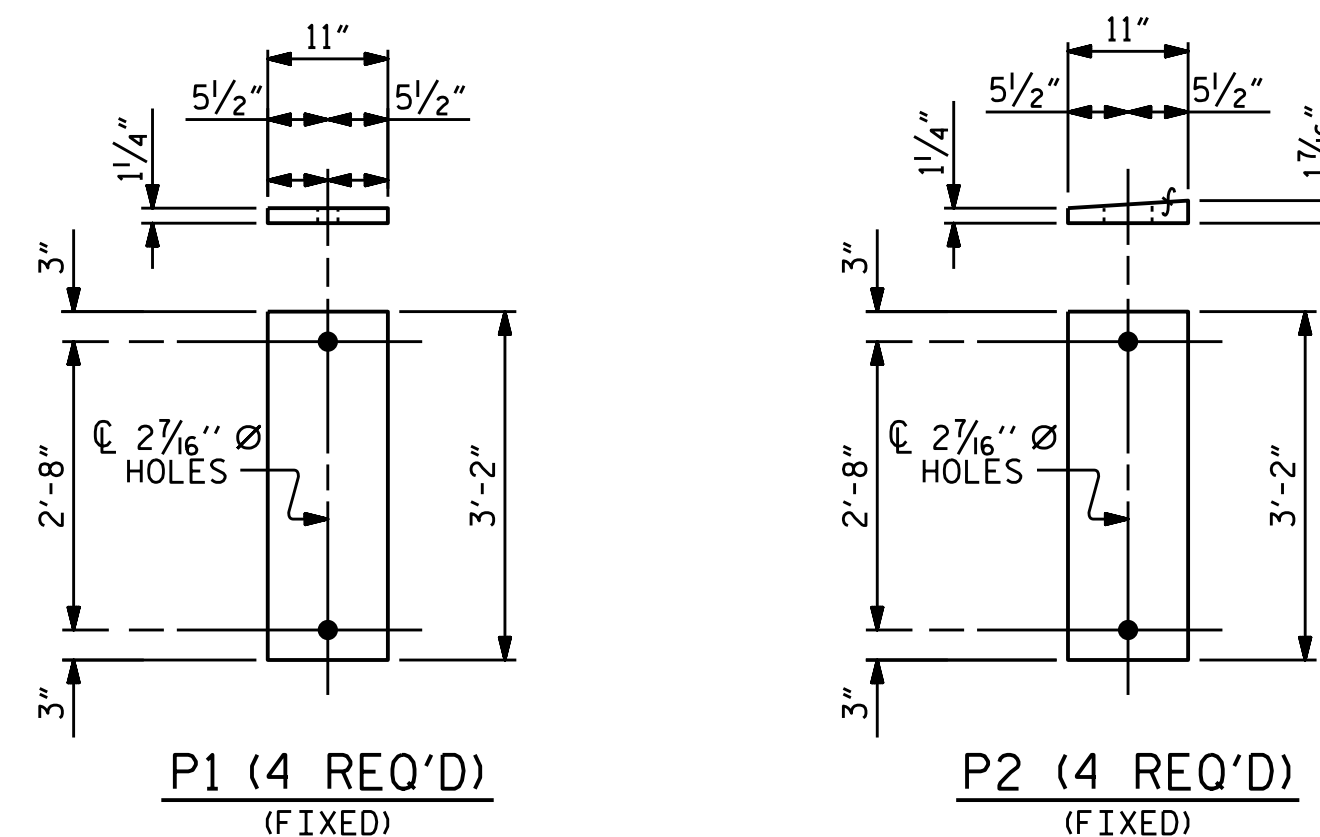

SOLE PLATE DETAILS (P)

MAXIMUM ALLOWABLE SERVICE LOADS	
D.L.+L.L. (NO IMPACT)	
TYPE V	365 k

PROJECT NO. U-2579C
FORSYTH COUNTY
 STATION: 21+27.27 -Y2-

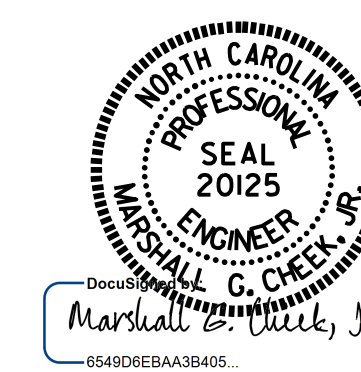

STATE OF NORTH CAROLINA
 DEPARTMENT OF TRANSPORTATION
 RALEIGH
 STANDARD
**ELASTOMERIC BEARING
 DETAILS**
 PRESTRESSED CONCRETE GIRDER
 SUPERSTRUCTURE

ASSEMBLED BY : N.D'AIUTO	DATE : 1/21/16
CHECKED BY : J.K.BOWLES	DATE : 3/31/16
DRAWN BY : EEM 2/97	REV. 10/1/11 MAA/GM
CHECKED BY : VAP 2/97	REV. 6/13 AAC/MAA
	REV. 1/15 MAA/TMG

DOCUMENT NOT CONSIDERED
 FINAL UNLESS ALL
 SIGNATURES COMPLETED

REVISIONS						SHEET NO.	
NO.	BY:	DATE:	NO.	BY:	DATE:	S2-14	
1			3			TOTAL SHEETS 30	
2			4				

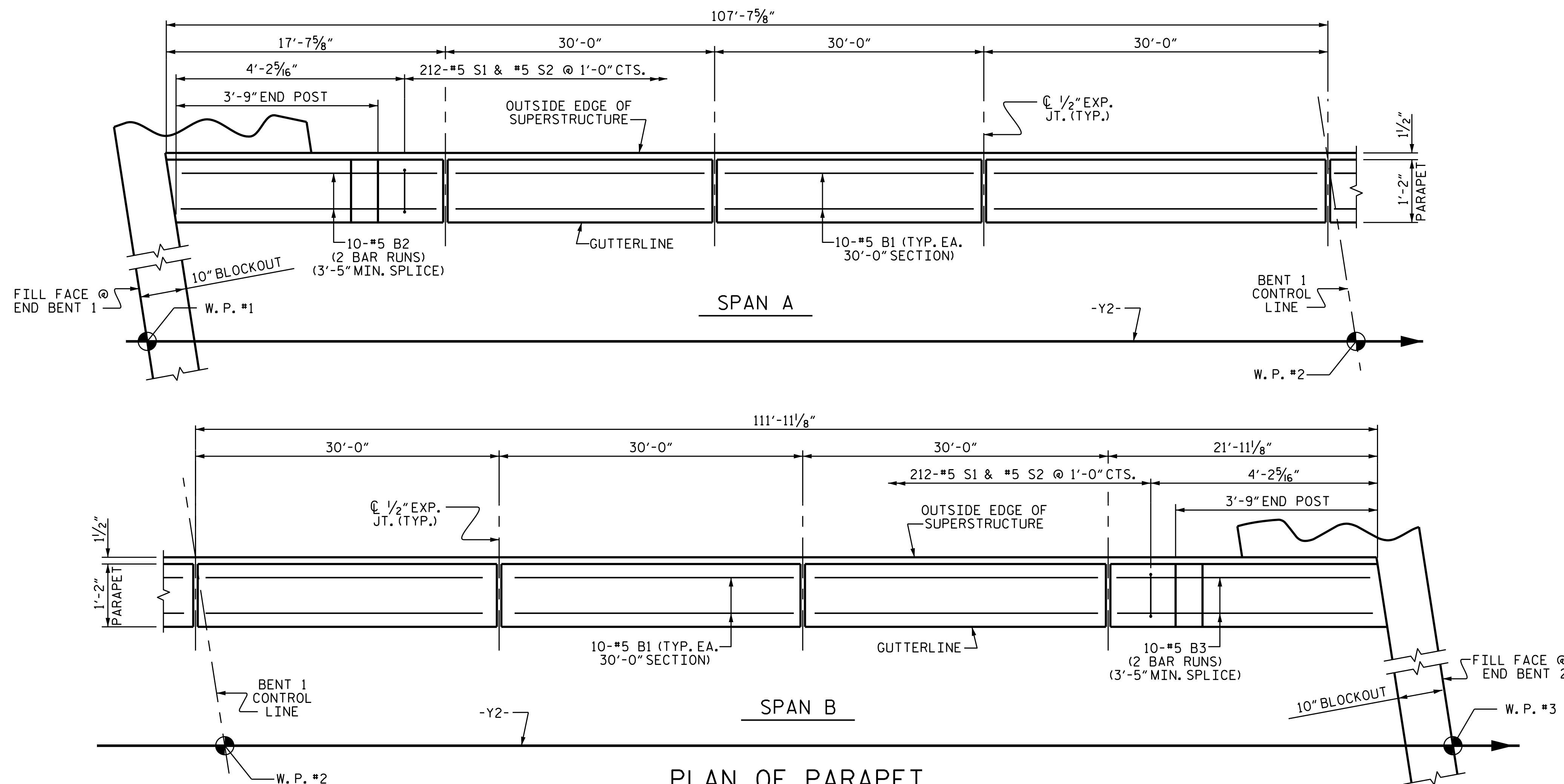

PLAN OF PARAPET
LEFT SIDE SHOWN, RIGHT SIDE SIMILAR

BAR TYPES

ALL BAR DIMENSIONS ARE OUT TO OUT.

BILL OF MATERIAL

PARAPET AND END POSTS

BAR	NO.	SIZE	TYPE	LENGTH	WEIGHT
* B1	120	#5	STR	29'-7"	3703
* B2	40	#5	STR	10'-4"	431
* B3	40	#5	STR	12'-7"	525
* E1	8	#7	STR	3'-3"	53
* E2	8	#7	STR	3'-9"	61
* E3	8	#7	STR	4'-3"	69
* E4	8	#7	STR	4'-8"	76
* E5	8	#7	STR	5'-0"	82
* F1	8	#6	STR	1'-10"	22
* F2	8	#6	STR	3'-2"	38
* F3	8	#6	STR	3'-7"	43
* S1	440	#5	1	6'-11"	3174
* S2	424	#5	2	5'-6"	2432

* EPOXY COATED REINFORCING STEEL	LBS.	10709
CLASS AA CONCRETE	C.Y.	62.1
1'-2" x 3'-2 3/4" CONCRETE PARAPET	LIN. FT.	439.13

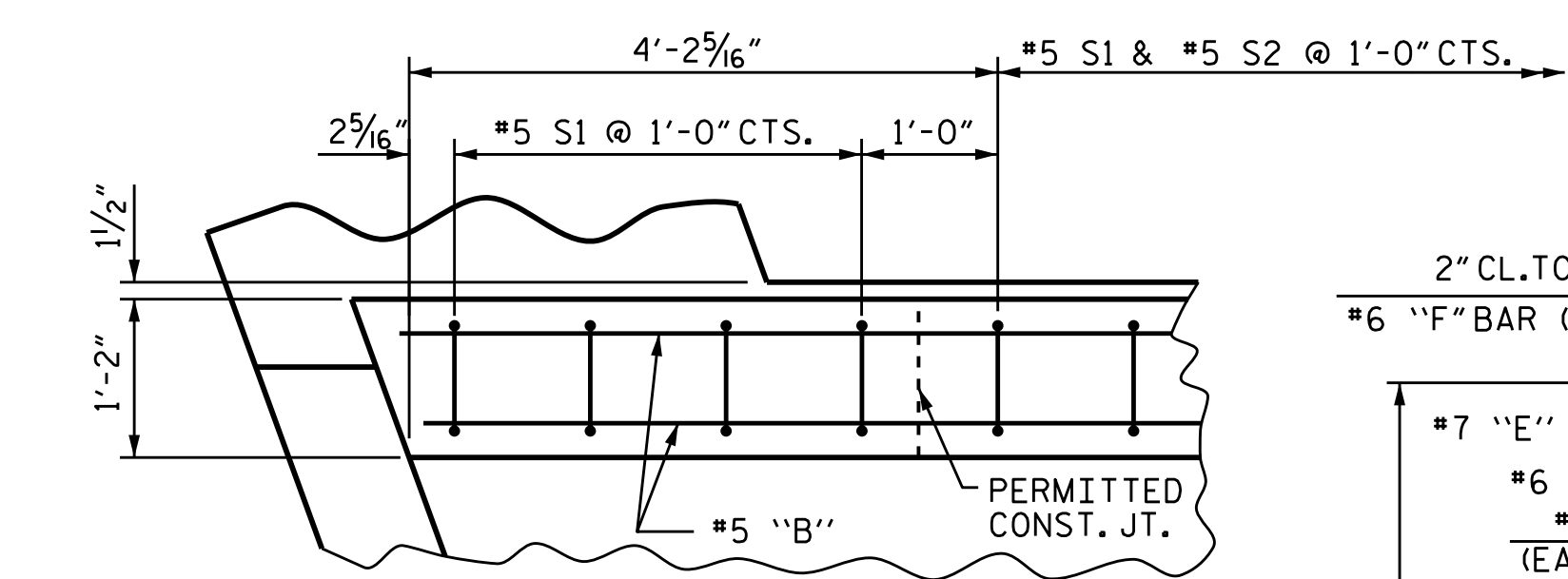

PLAN OF PARAPET

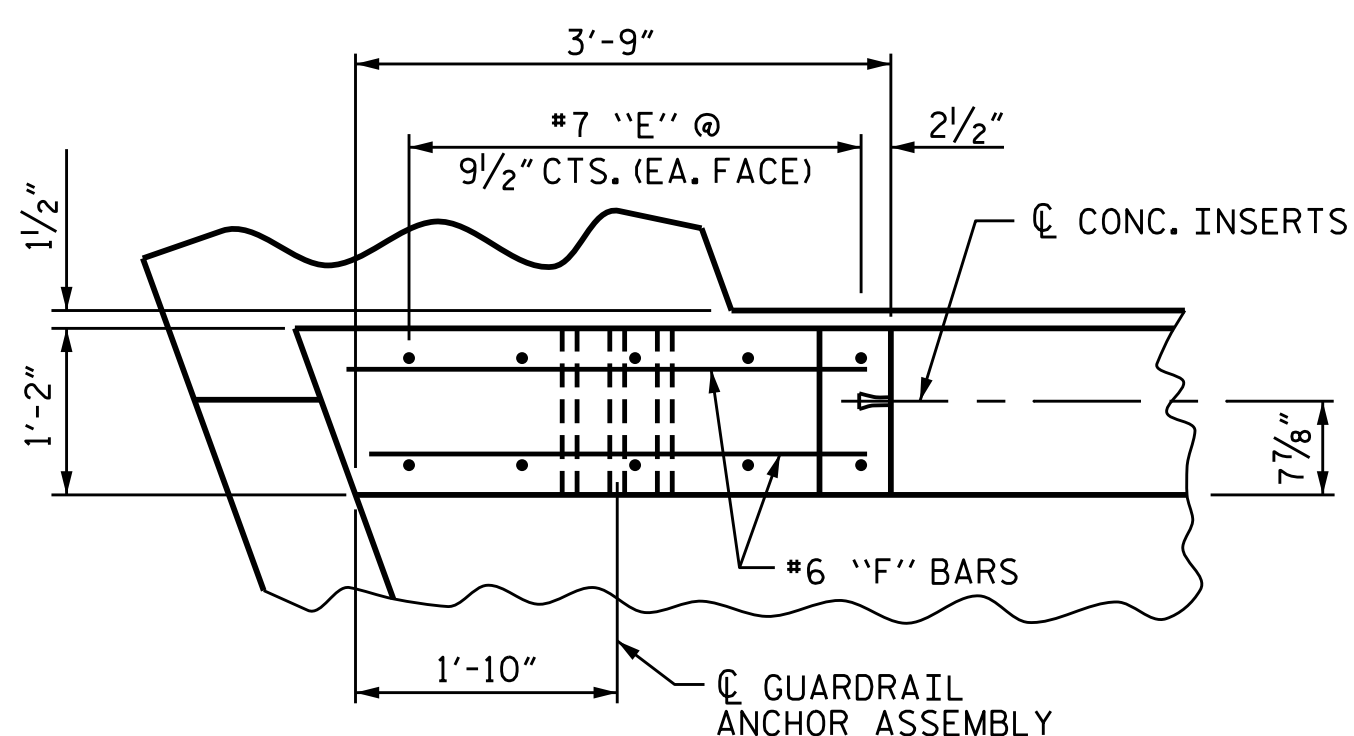

PLAN OF END POST

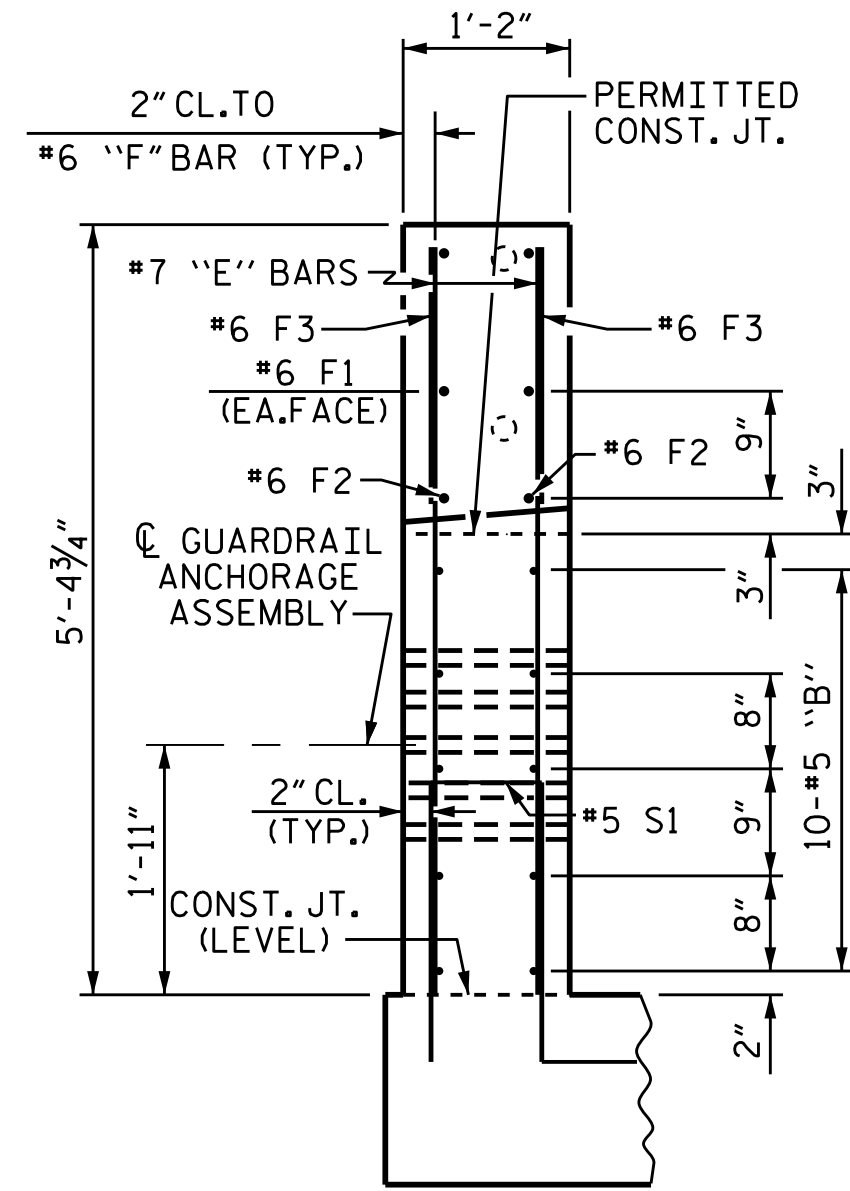

END VIEW

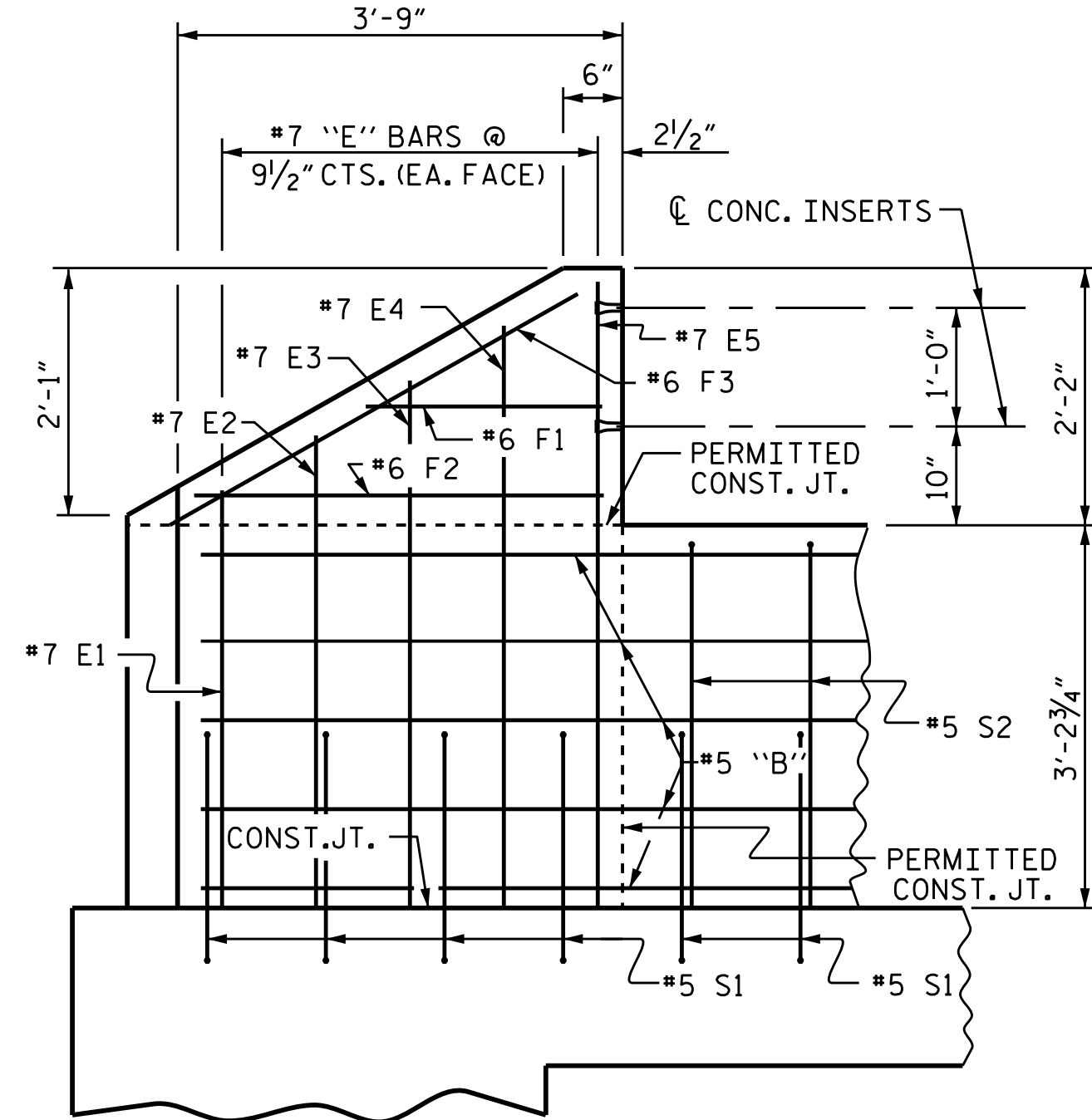

ELEVATION

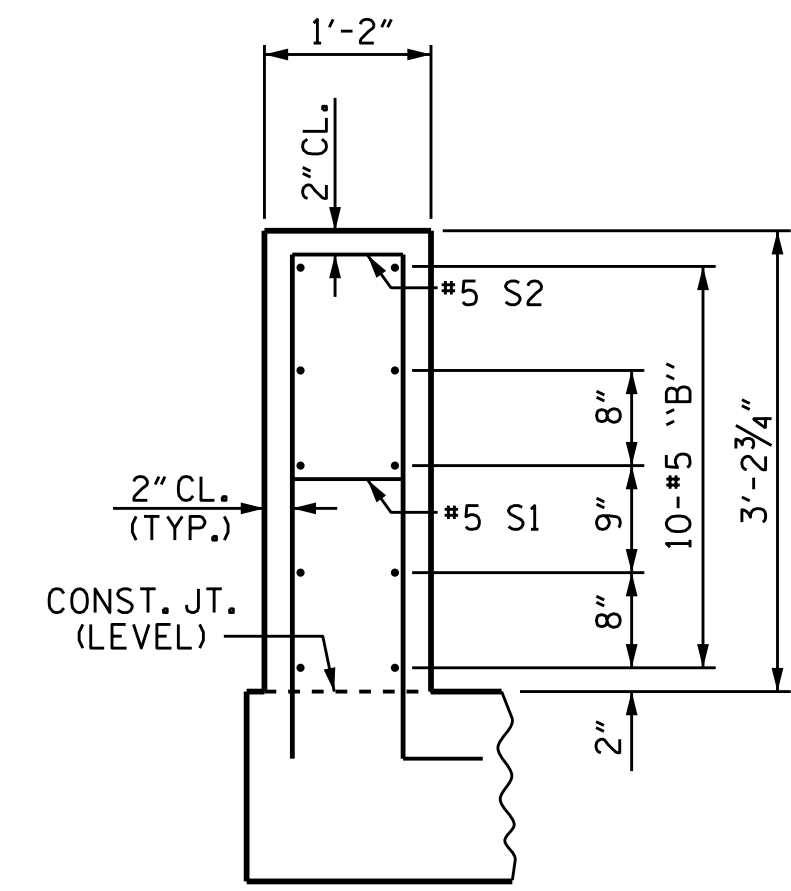

SECTION THROUGH PARAPET

DRAWN BY : N. D'AIUTO DATE : 1/19/16
 CHECKED BY : J.K.BOWLES DATE : 3/31/16
 DESIGN ENGINEER OF RECORD : J.K.BOWLES DATE : 3/31/16

PARAPET AND END POST FOR TWO BAR RAIL

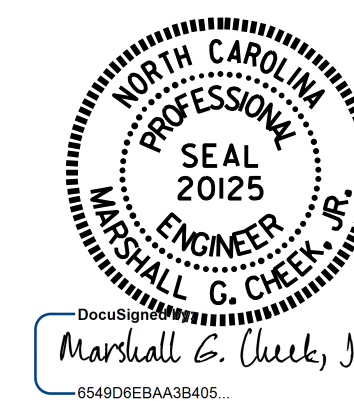

7/27/2017

DOCUMENT NOT CONSIDERED FINAL UNLESS ALL SIGNATURES COMPLETED

PROJECT NO. U-2579C
 FORSYTH COUNTY
 STATION: 21+27.27 -Y2-
 SHEET 1 OF 5

STATE OF NORTH CAROLINA
 DEPARTMENT OF TRANSPORTATION
 RALEIGH
 1'-2" X 3'-2 3/4" CONCRETE PARAPET AND END POST DETAILS FOR TWO BAR METAL RAIL

REVISIONS					SHEET NO.
NO.	BY:	DATE:	NO.	BY:	DATE:
1			3		
2			4		

S2-15
TOTAL SHEETS 30

STR. #2

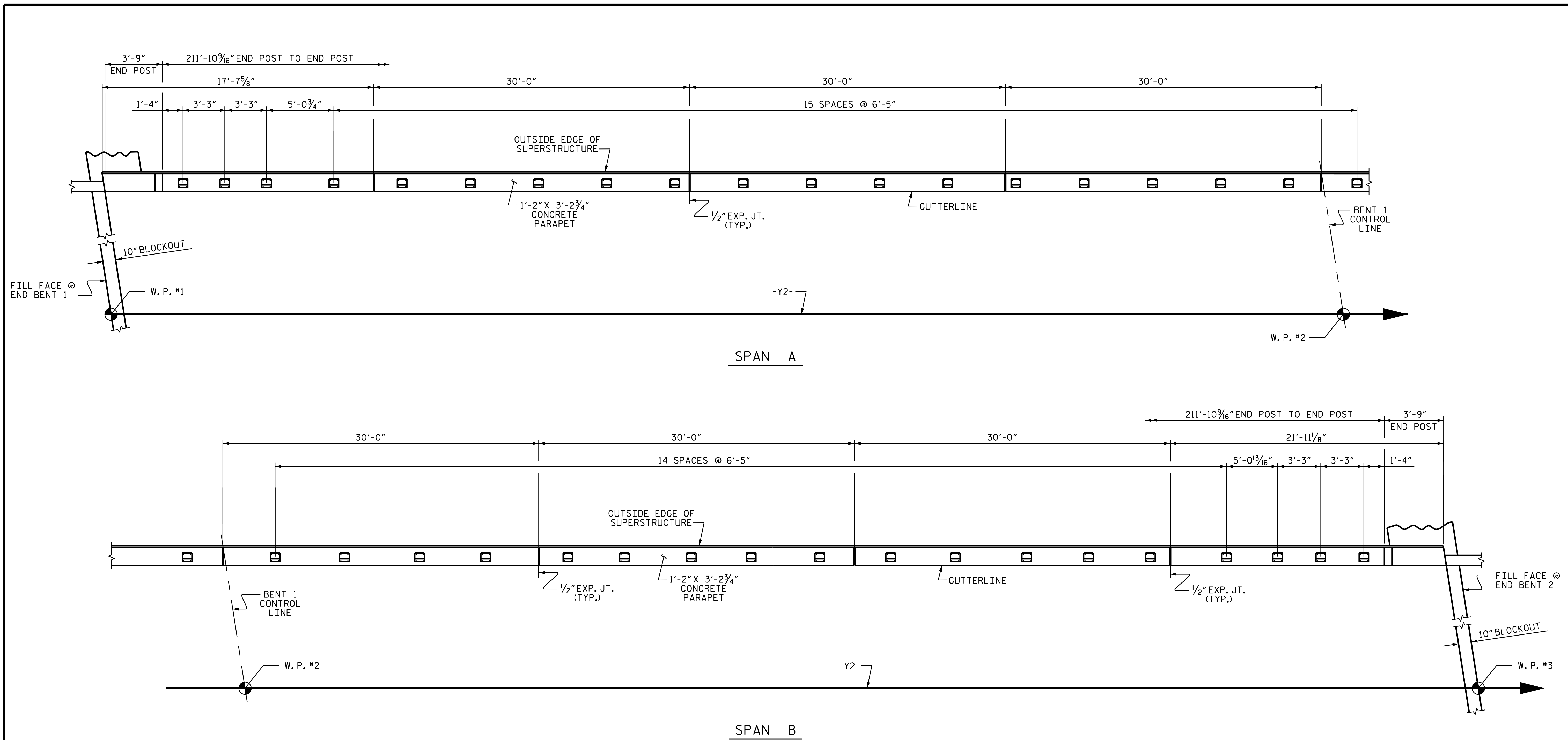

PLAN OF RAIL POST SPACING

LEFT SIDE SHOWN, RIGHT SIDE SIMILAR.

PROJECT NO. U-2579C
FORSYTH COUNTY
 STATION: 21+27.27 -Y2-

SHEET 2 OF 5

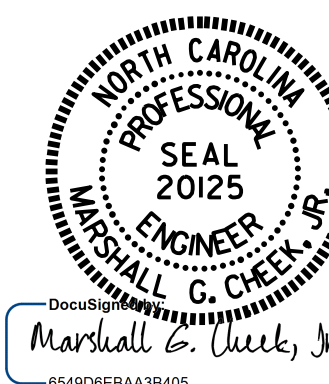

STATE OF NORTH CAROLINA
 DEPARTMENT OF TRANSPORTATION
 RALEIGH

SUPERSTRUCTURE
 PLAN OF RAIL
 POST SPACING

DRAWN BY : N. D'AIUTO DATE : 1/14/16
 CHECKED BY : J.K. BOWLES DATE : 3/31/16
 DESIGN ENGINEER OF RECORD : J.K. BOWLES DATE : 3/31/16

DOCUMENT NOT CONSIDERED
 FINAL UNLESS ALL
 SIGNATURES COMPLETED

REVISIONS						SHEET NO.	
NO.	BY:	DATE:	NO.	BY:	DATE:	S2-16	
1			3			TOTAL	16
2			4			SHEETS	30

STR. #2

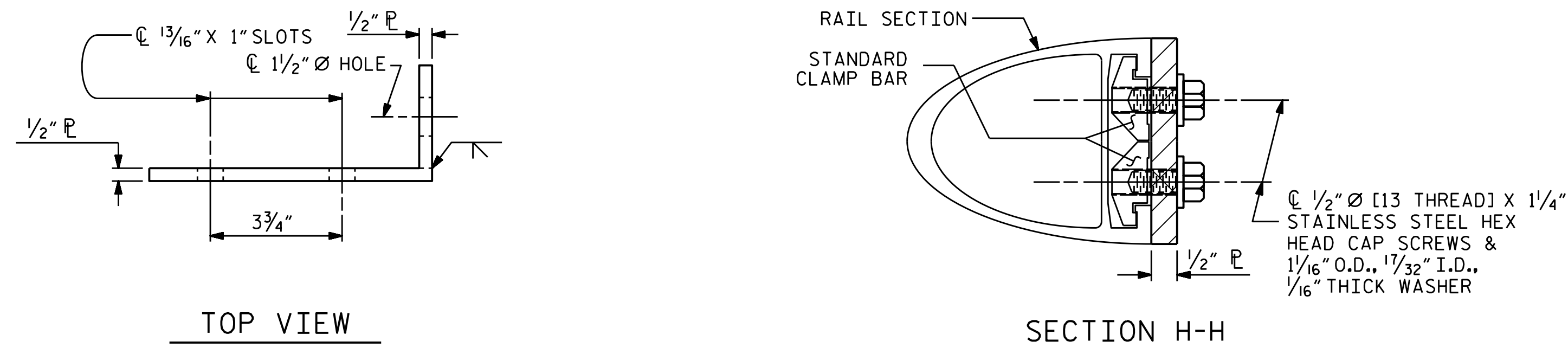
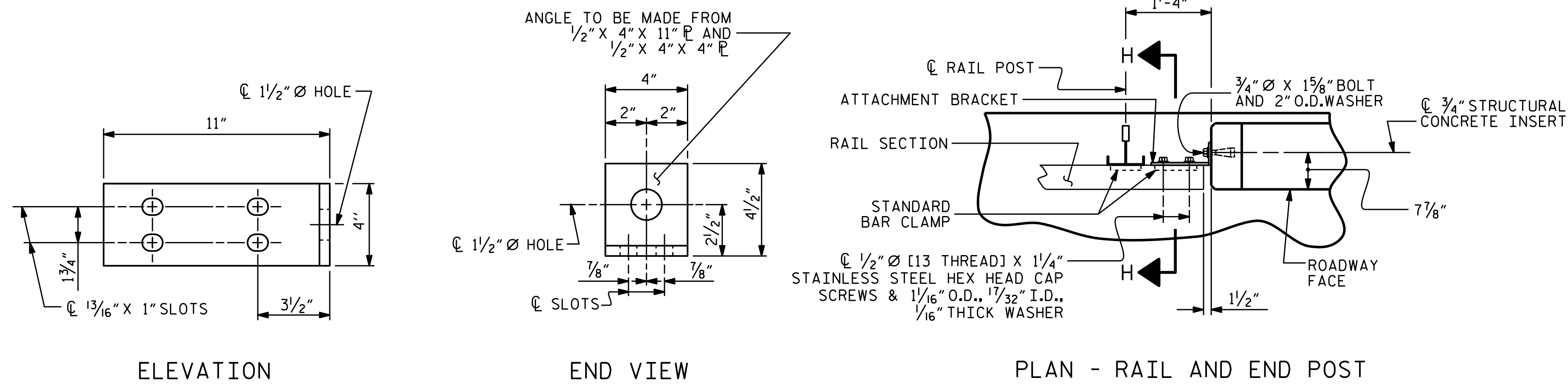

DETAILS FOR ATTACHING METAL RAIL TO END POST

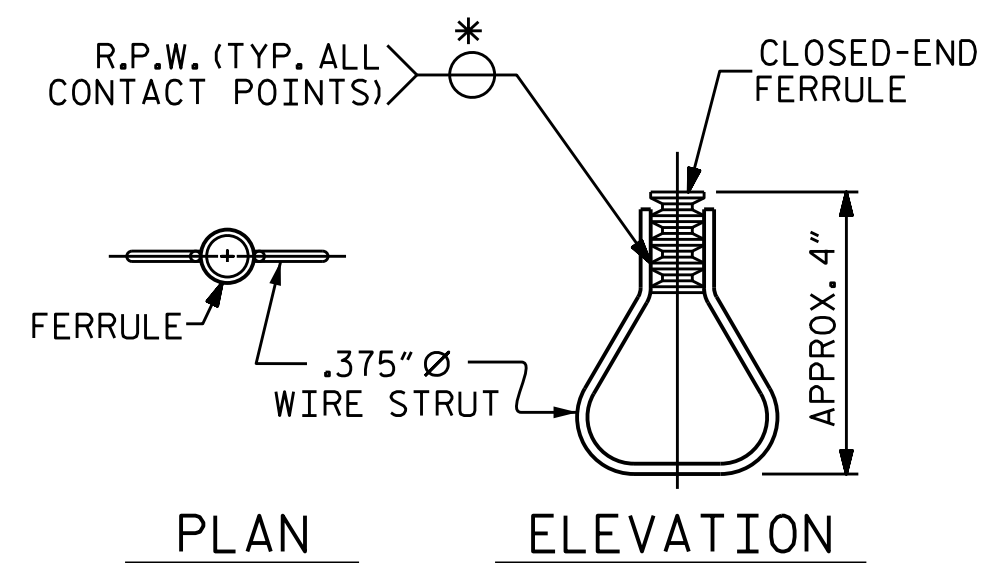

STRUCTURAL CONCRETE INSERT

* EACH WELDED ATTACHMENT OF WIRE TO FERRULE SHALL DEVELOP THE TENSILE STRENGTH OF THE WIRE.

NOTES

STRUCTURAL CONCRETE INSERT

- THE STRUCTURAL CONCRETE INSERT ASSEMBLY SHALL CONSIST OF THE FOLLOWING COMPONENTS:
- FERRULES SHALL BE MADE FROM STEEL MEETING THE REQUIREMENTS OF AASHTO M169, GRADE 12L14 AND SHALL HAVE A MINIMUM LENGTH OF THREADS OF 1/2".
 - 1 - 3/4" Ø X 1 5/8" BOLT WITH WASHER. BOLT SHALL CONFORM TO THE REQUIREMENTS OF ASTM A307. BOLT AND WASHER SHALL BE GALVANIZED. (AT THE CONTRACTOR'S OPTION, STAINLESS STEEL BOLT AND WASHER MAY BE USED AS AN ALTERNATE FOR THE 3/4" Ø X 1 5/8" GALVANIZED BOLT AND WASHER. THEY SHALL CONFORM TO OR EXCEED THE MECHANICAL REQUIREMENTS OF ASTM A307. THE USE OF THIS ALTERNATE SHALL BE APPROVED BY THE ENGINEER.)
 - WIRE STRUT SHOWN IN THE CONCRETE INSERT ASSEMBLY DETAIL IS THE MINIMUM ALLOWABLE SIZE AND SHALL HAVE A MINIMUM TENSILE STRENGTH OF 100,000 PSI. AS AN OPTION, A 1/16" Ø WIRE STRUT WITH A MINIMUM TENSILE STRENGTH OF 90,000 PSI IS ACCEPTABLE.

NOTES

METAL RAIL TO END POST CONNECTION

- THE METAL RAIL TO END POST CONNECTION SHALL CONSIST OF THE FOLLOWING COMPONENTS:
- 1/2" PLATES SHALL CONFORM TO AASHTO M270 GRADE 36 AND SHALL BE GALVANIZED AFTER FABRICATION.
 - 3/4" STRUCTURAL CONCRETE INSERT SHALL HAVE A WORKING LOAD SHEAR CAPACITY OF 4800 LBS. THE FERRULES SHALL ENGAGE A 3/4" Ø X 1 5/8" BOLT WITH 2" O.D. WASHER IN PLACE. THE 3/4" Ø X 1 5/8" BOLT SHALL HAVE N.C. THREADS.
 - CAP SCREWS FOR RAIL ATTACHMENT TO ANGLE SHALL CONFORM TO THE REQUIREMENTS OF ASTM F593 ALLOY 305 STAINLESS STEEL. CAP SCREWS TO BE CENTERED IN SLOTS AT 60°.
 - STANDARD CLAMP BARS (SEE METAL RAIL SHEET).
 - 1/2" Ø PIPE SLEEVES (IF REQUIRED) TO BE GALVANIZED.
- THE COST OF THE STANDARD CLAMP BARS AND CAP SCREWS USED IN THE METAL RAIL TO END POST CONNECTION SHALL BE INCLUDED IN THE UNIT CONTRACT PRICE BID FOR LINEAR FEET OF 2 BAR METAL RAILS.
- THE 3/4" STRUCTURAL CONCRETE INSERT WITH BOLT SHALL BE ASSEMBLED IN THE SHOP.
- THE COST OF THE 3/4" STRUCTURAL CONCRETE INSERT ASSEMBLY, AND THE 1/2" PLATES COMPLETE IN PLACE SHALL BE INCLUDED IN THE VARIOUS PAY ITEMS.
- THE CONTRACTOR, AT HIS OPTION, MAY USE AN ADHESIVE BONDING SYSTEM IN LIEU OF THE STRUCTURAL CONCRETE INSERT EMBEDDED IN THE END POST. IF THE ADHESIVE BONDING SYSTEM IS USED, THE 3/4" Ø X 1 5/8" BOLT WITH WASHER SHALL BE REPLACED WITH A 3/4" Ø X 6 1/2" BOLT AND 2" O.D. WASHER. ALL SPECIFICATIONS THAT APPLY TO THE 3/4" Ø X 1 5/8" BOLT SHALL APPLY TO THE 3/4" Ø X 6 1/2" BOLT. FIELD TESTING OF THE ADHESIVE BONDING SYSTEM IS NOT REQUIRED.

ASSEMBLED BY : N.D. AIUTO	DATE : 1/14/16
CHECKED BY : J.K. BOWLES	DATE : 3/31/16
DRAWN BY : FCJ 1/88	REV. 5/7/03 RWW/JTE
CHECKED BY : CRK 3/89	REV. 5/1/06 TLA/GM
	REV. 10/1/11 MAA/GM

26-JUL-2017 15:06
 R:\Structures\FINAL PLANS\402.033.U2579C.SMU.2MR.017.330701.dgn
 mcheek

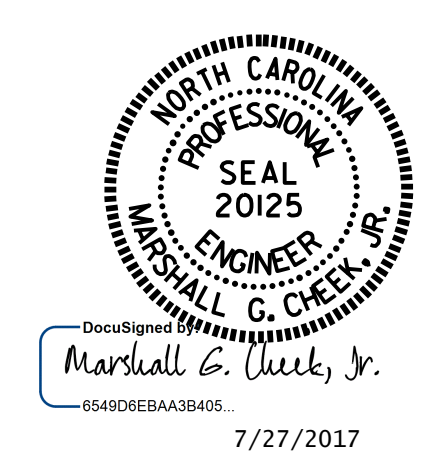

DOCUMENT NOT CONSIDERED FINAL UNLESS ALL SIGNATURES COMPLETED

PROJECT NO. U-2579C
FORSYTH COUNTY
 STATION: 21+27.27 -Y2-

SHEET 3 OF 5

STATE OF NORTH CAROLINA
 DEPARTMENT OF TRANSPORTATION
 RALEIGH
 STANDARD
 RAIL POST SPACINGS
 AND
 END OF RAIL DETAILS

REVISIONS						SHEET NO.	
NO.	BY:	DATE:	NO.	BY:	DATE:	S2-17	
1			3			TOTAL SHEETS 30	
2			4				

STR. #2 STD. NO. BMR2

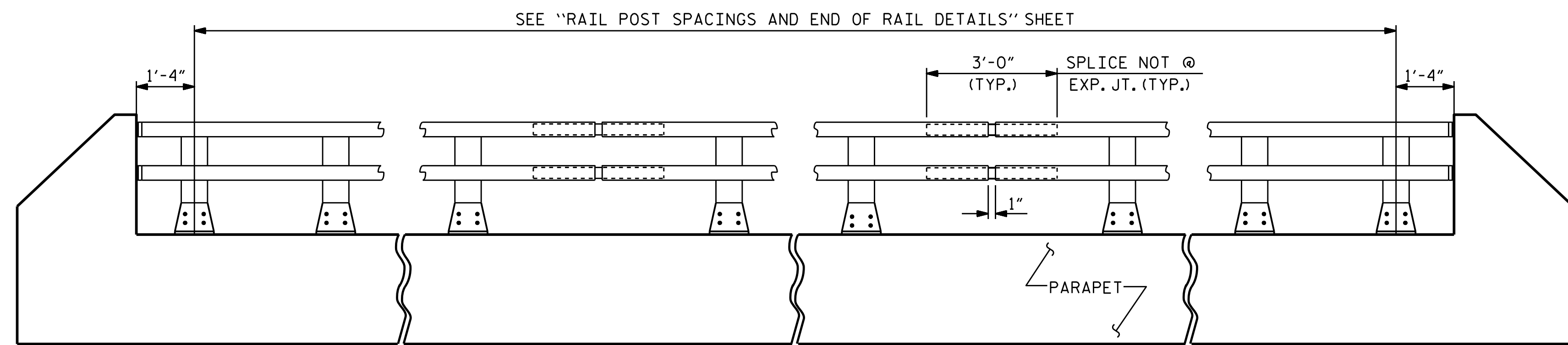

ELEVATION

NOTE : FOR ATTACHMENT OF METAL RAIL TO END POST, SEE SHEET 3 OF 5.

NOTES

AT THE CONTRACTOR'S OPTION, METAL RAIL MAY BE EITHER ALUMINUM OR GALVANIZED STEEL IN ACCORDANCE WITH THE REQUIREMENTS OF THE GENERAL NOTES AND THE FOLLOWING SPECIFICATIONS FOR THE ALTERNATE MATERIALS; HOWEVER, THE CONTRACTOR WILL BE REQUIRED TO USE THE SAME RAIL MATERIAL ON ALL STRUCTURES ON THE PROJECT FOR WHICH METAL RAIL IS DESIGNATED.

UNLESS OTHERWISE REQUIRED IN THE CONTRACT DOCUMENTS, THE CONTRACTOR HAS THE OPTION TO USE AN ALTERNATE TO THE 2 BAR METAL RAIL. THE ALTERNATE RAIL SHALL MEET THE REQUIREMENTS OF THE AASHTO LRFD BRIDGE DESIGN SPECIFICATIONS AND MUST BE LISTED ON THE DEPARTMENT'S APPROVED PRODUCTS LIST (APL) UNDER "2 BAR METAL RAIL ALTERNATE". ADJUSTMENTS TO THE CONCRETE PARAPET WILL NOT BE ALLOWED.

ALUMINUM RAILS

MATERIAL FOR POSTS, BASES AND RAILS, EXPANSION BARS AND CLAMP BARS SHALL BE ASTM B-221 ALLOY 6061-T6. MATERIAL FOR RIVETS SHALL BE ASTM B316 ALLOY 6061-T6. RIVETS SHALL BE STANDARD BUTTON HEAD AND CONE POINT COLD DRIVEN AS PER DRAWING.

THE BASE OF RAIL POSTS, OR ANY OTHER ALUMINUM SURFACE IN CONTACT WITH CONCRETE SHALL BE THOROUGHLY COATED WITH AN ALUMINUM IMPREGNATED CAULKING COMPOUND OF APPROVED QUALITY.

MATERIAL FOR SHIMS TO BE ASTM B209 ALLOY 6061-T6.

GALVANIZED STEEL RAILS

MATERIAL AND GALVANIZING ARE TO CONFORM TO THE FOLLOWING SPECIFICATIONS:

POST, POST BASES, RAILS, EXPANSION BARS AND CLAMP BARS: AASHTO M270 GRADE 36 STRUCTURAL STEEL - GALVANIZED TO AASHTO M111.

RIVETS: RIVETS SHALL MEET THE REQUIREMENTS OF ASTM A502 FOR GRADE 1 RIVETS.

THE CUT ENDS OF GALVANIZED STEEL RAILING, AFTER GRINDING SMOOTH SHALL BE GIVEN TWO COATS OF ZINC RICH PAINT MEETING THE REQUIREMENTS OF FEDERAL SPECIFICATION MIL-P-26915 USAF TYPE 1, OR OF FEDERAL SPECIFICATIONS TT-P-641.

SHIMS: SHIMS SHALL MEET THE REQUIREMENTS OF ASTM A570 FOR GRADE 33 OR A611 FOR GRADE C AND SHALL BE GALVANIZED IN ACCORDANCE WITH AASHTO M111.

RAIL CAPS: RAIL CAPS SHALL MEET THE REQUIREMENTS OF ASTM A570 FOR GRADE 33 OR A611 FOR GRADE C AND SHALL BE GALVANIZED IN ACCORDANCE WITH AASHTO M111.

GENERAL NOTES

RAILING SHALL BE CONTINUOUS FROM END POST TO END POST OF BRIDGE. EACH JOINT IN RAIL LENGTH SHALL BE SPLICED AS DETAILED. PANEL LENGTHS OF RAIL SHALL BE ATTACHED TO A MINIMUM OF THREE POSTS.

FOR END OF RAIL TO CLEAR FACE OF CONCRETE END POST DIMENSION, SEE SHEET 3 OF 5.

CAP SCREWS SHALL BE ASTM F593 ALLOY 305 STAINLESS STEEL. WASHERS SHALL MEET THE REQUIREMENTS OF ASTM F844 EXCEPT THEY SHALL BE MADE FROM ALLOY 304 STAINLESS STEEL.

CERTIFIED MILL REPORTS ARE REQUIRED FOR RAILS AND POSTS. SHOP INSPECTION IS NOT REQUIRED.

METAL RAIL POSTS SHALL BE SET NORMAL TO CURB GRADE.

METHOD OF MEASUREMENT FOR METAL RAILS: FOR LENGTH OF METAL RAILS TO BE PAID FOR, SEE THE STANDARD SPECIFICATIONS.

CURVED RAIL USAGE: WHERE RAILS ARE TO BE USED ON BRIDGES ON HORIZONTAL AND/OR VERTICAL CURVATURE THE CONTRACTOR MAY, AT HIS OPTION, HAVE THE REQUIRED CURVATURE IN THE RAIL FORMED IN THE SHOP OR IN THE FIELD. IN EITHER EVENT, THE RAIL SHALL CONFORM WITHOUT BUCKLING OR KINKING TO THE REQUIRED CURVATURE IN A UNIFORM MANNER ACCEPTABLE TO THE ENGINEER.

TO INSURE FUTURE IDENTIFICATION OF THE FABRICATOR, A PERMANENT IDENTIFYING MARK SHALL BE PLACED ON EACH POST. THE METHOD OF MARKING AND LOCATION SHALL BE SUCH THAT IT DOES NOT DETRACT FROM THE APPEARANCE OF THE POST, BUT REMAINS VISIBLE AFTER RAIL PLACEMENT.

SHIMS SHALL BE USED AS NECESSARY FOR POST ALIGNMENT.

ALLOY 6351-T5 MAY BE SUBSTITUTED FOR ALLOY 6061-T6 WHERE APPLICABLE.

MINOR VARIATIONS IN DETAILS OF METAL RAIL WILL BE CONSIDERED. DETAILS OF SUCH VARIATIONS, IF DESIRED, SHALL BE SUBMITTED FOR APPROVAL.

GROOVED CONTRACTION JOINTS, 1/2" IN DEPTH, SHALL BE TOOLED IN ALL EXPOSED FACES OF THE PARAPET AND IN ACCORDANCE WITH ARTICLE 825-10(B) OF THE STANDARD SPECIFICATIONS. A CONTRACTION JOINT SHALL BE LOCATED AT EACH THIRD POINT BETWEEN PARAPET EXPANSION JOINTS. ONLY ONE CONTRACTION JOINT IS REQUIRED AT MIDPOINT OF PARAPET SEGMENTS LESS THAN 20 FEET IN LENGTH AND NO CONTRACTION JOINTS ARE REQUIRED FOR THOSE SEGMENTS LESS THAN 10 FEET IN LENGTH.

PAY LENGTH = 423.76 LIN. FT.

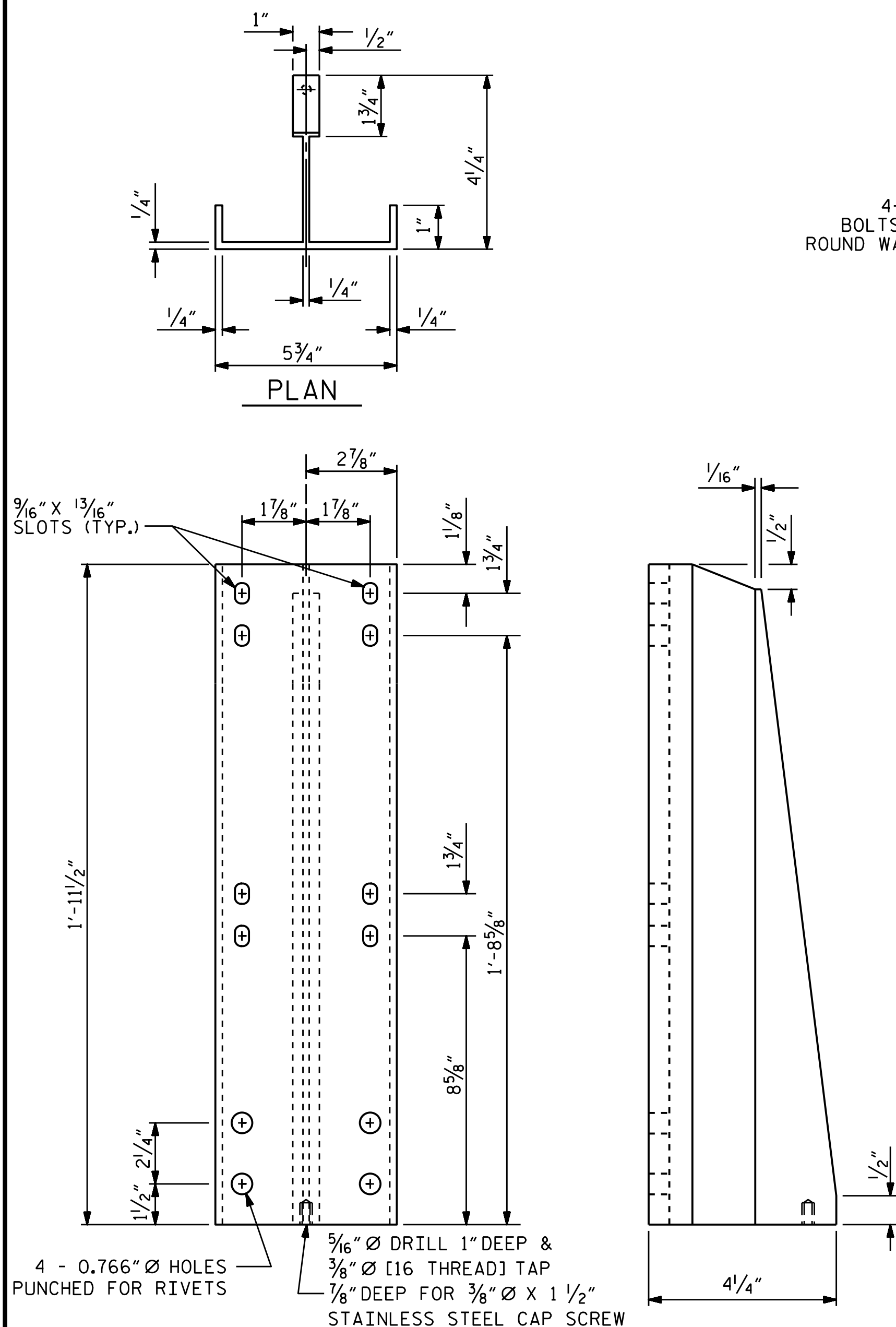

FRONT ELEVATION SIDE ELEVATION
DETAILS OF POST

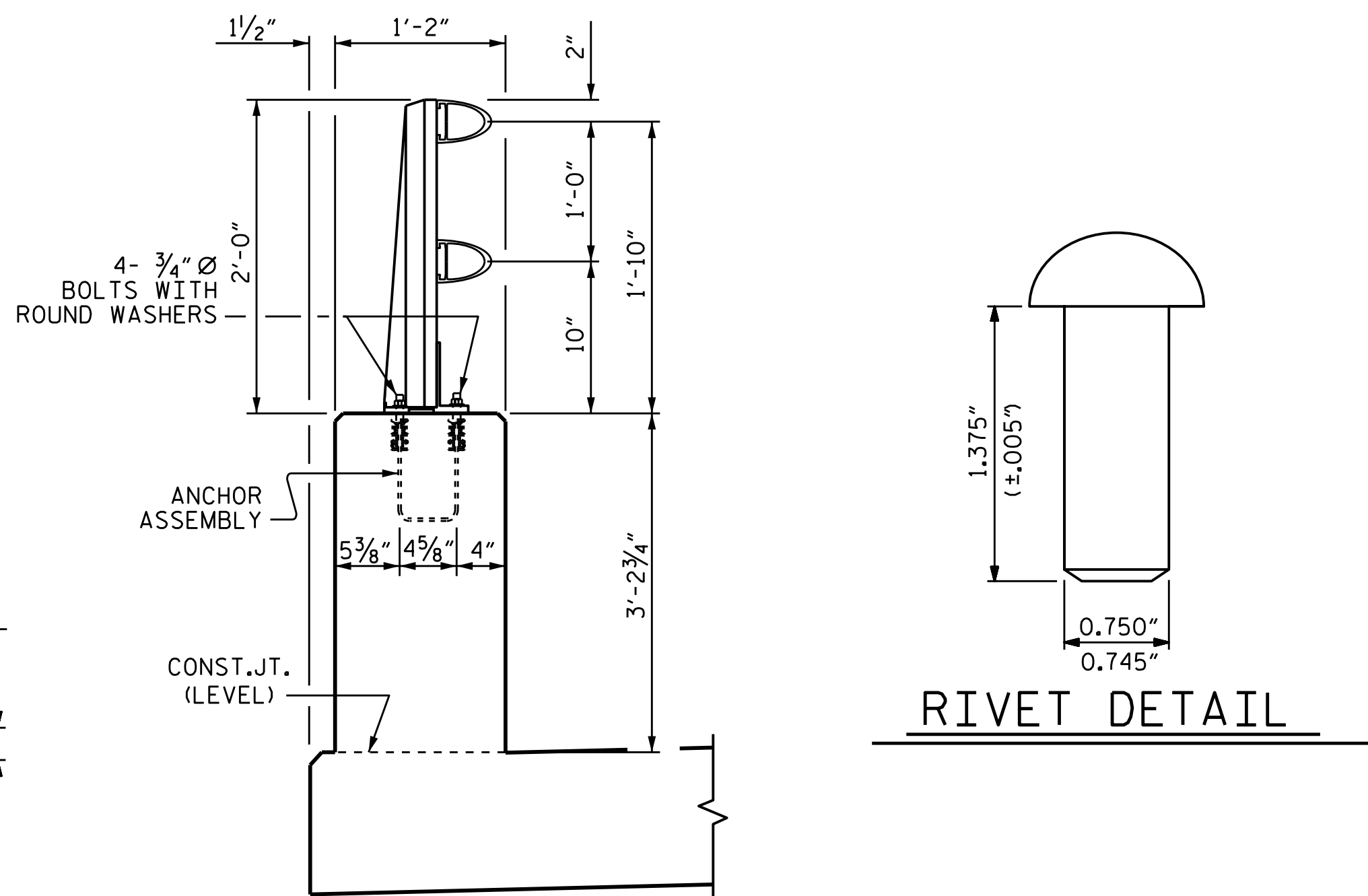

SECTION THROUGH PARAPET AND RAIL

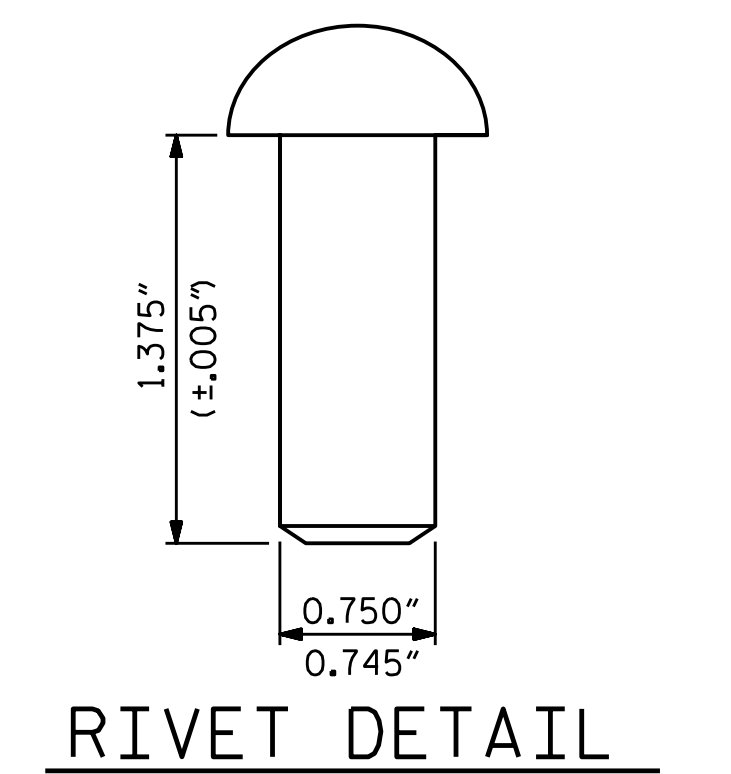

RIVET DETAIL

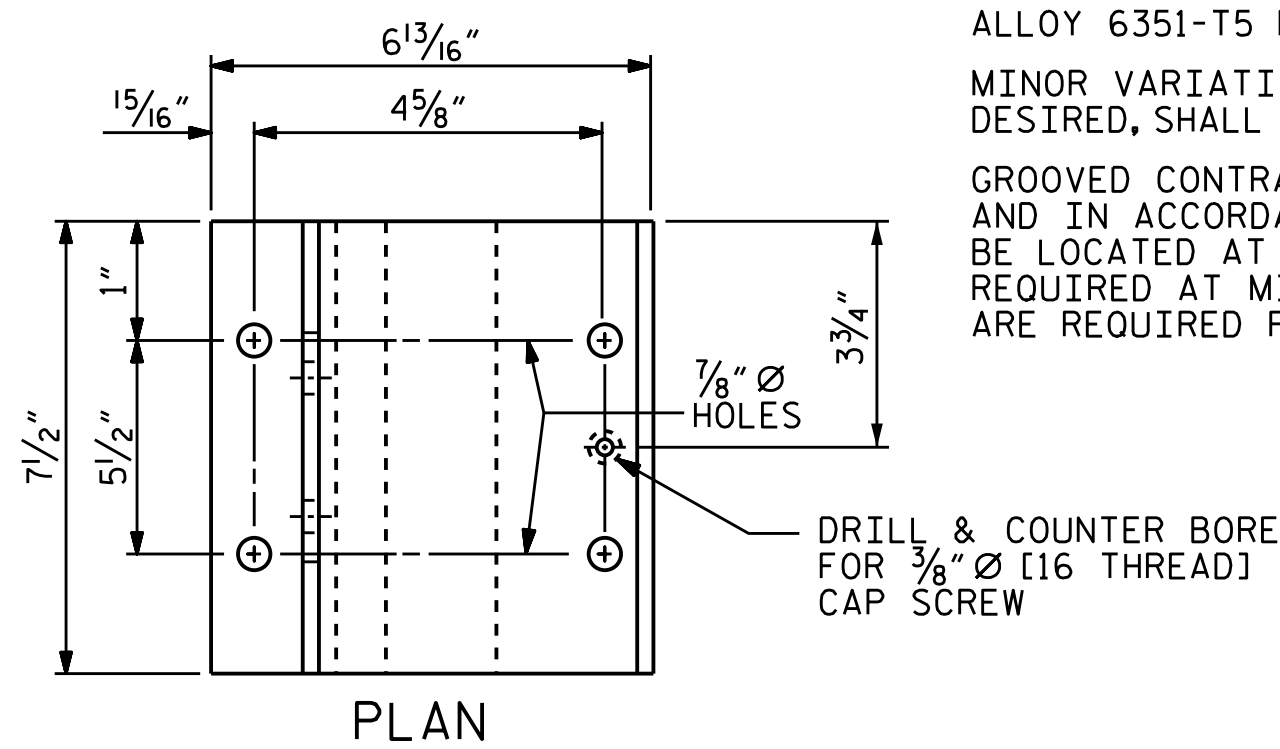

PLAN

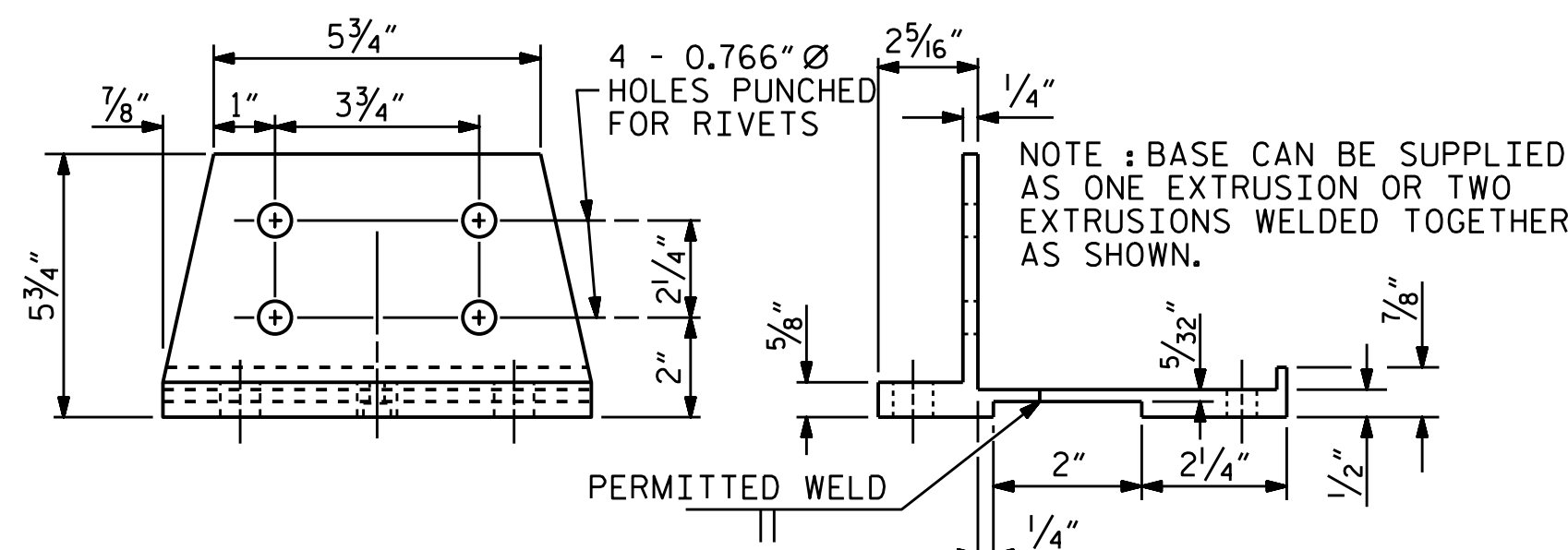

FRONT ELEVATION SIDE ELEVATION
POST BASE DETAILS

ASSEMBLED BY : N.D'AIUTO	DATE : 1/14/16
CHECKED BY : J.K.BOWLES	DATE : 3/31/16
DRAWN BY : EEM 6/94	REV. 5/1/06 TLA/GM
CHECKED BY : RGW 6/94	REV. 10/1/11 MAA/GM
	REV. 6/13 MAA/GM

26-JUL-2017 15:06
R:\Structures\FINAL PLANS\402.035.U2579C.SMU.2MR_018.330701.dgn
mcneek

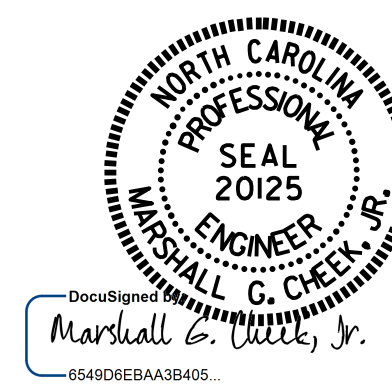

DOCUMENT NOT CONSIDERED FINAL UNLESS ALL SIGNATURES COMPLETED

PROJECT NO. U-2579C
FORSYTH COUNTY
STATION: 21+27.27 -Y2-

SHEET 4 OF 5

STATE OF NORTH CAROLINA
DEPARTMENT OF TRANSPORTATION
RALEIGH
STANDARD
2 BAR METAL RAIL

REVISIONS						SHEET NO.	
NO.	BY:	DATE:	NO.	BY:	DATE:	S2-18	
1			3			TOTAL SHEETS 30	
2			4				

STR. #2 STD. NO. BMR3

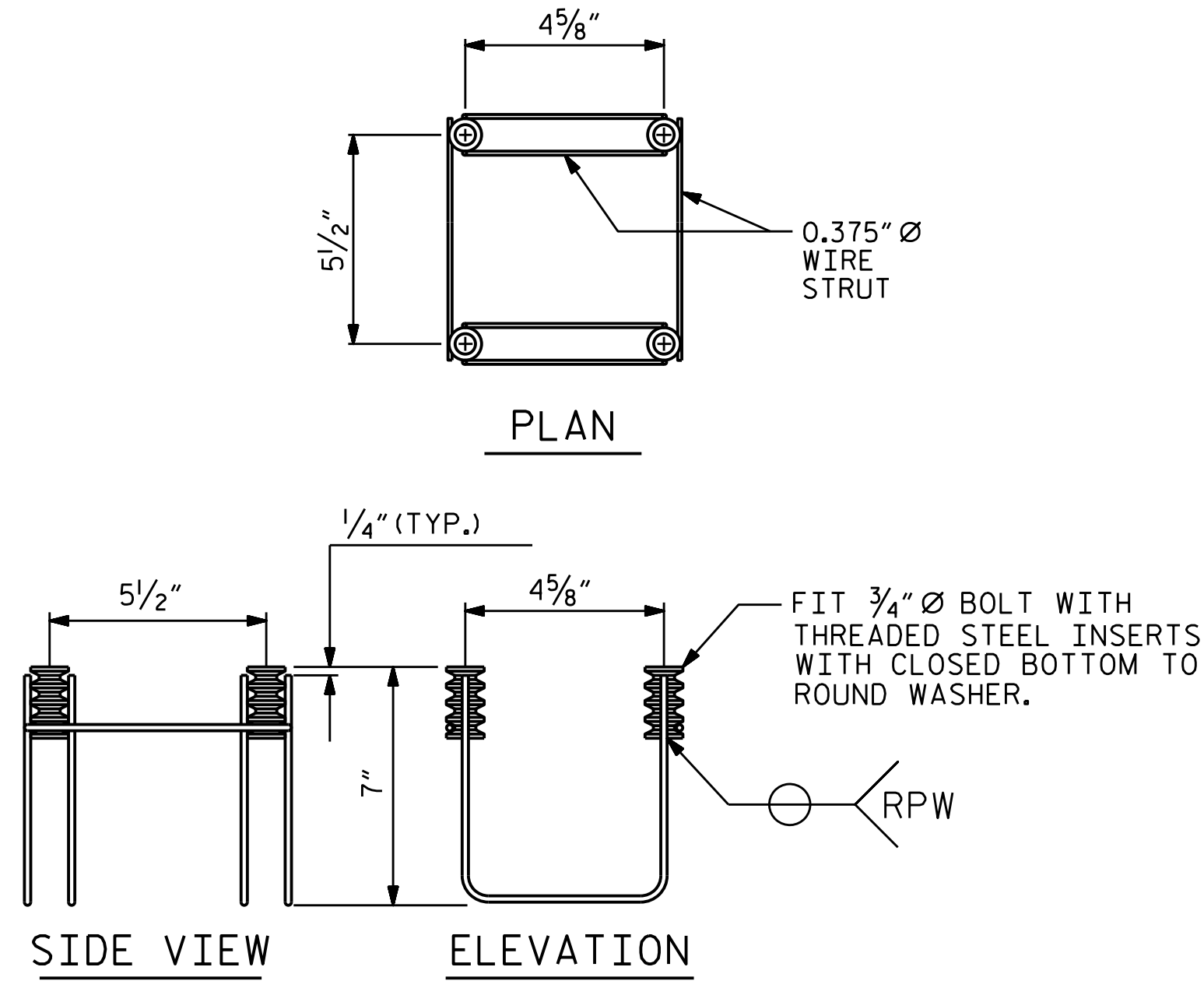
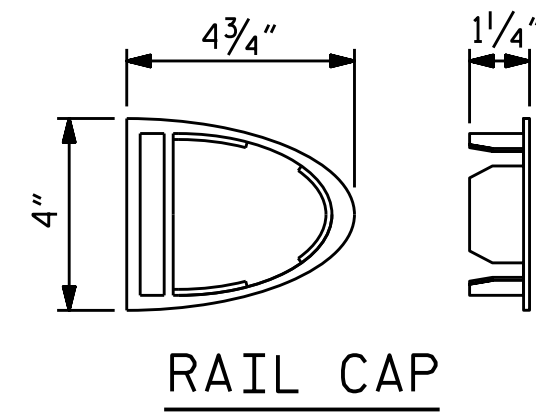
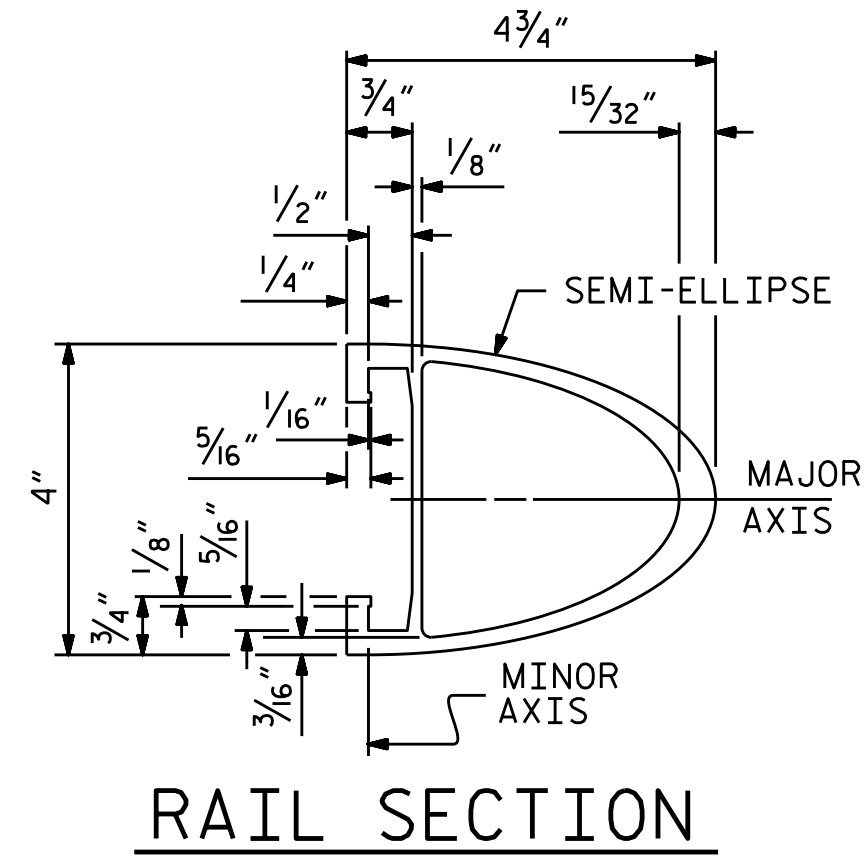

4-BOLT METAL RAIL ANCHOR ASSEMBLY
(72 ASSEMBLIES REQUIRED)

NOTES

- STRUCTURAL CONCRETE ANCHOR ASSEMBLY
- THE STRUCTURAL CONCRETE ANCHOR ASSEMBLY SHALL CONSIST OF THE FOLLOWING COMPONENTS :
- FERRULES SHALL BE MADE FROM STEEL MEETING THE REQUIREMENTS OF AASHTO M169, GRADE 12L14 AND SHALL HAVE A MINIMUM LENGTH OF THREADS OF 2" FOR 3/4" FERRULES.
 - 4 - 3/4" diameter x 2 1/2" BOLTS WITH WASHERS. BOLTS SHALL CONFORM TO THE REQUIREMENTS OF ASTM A307. BOLTS AND WASHERS SHALL BE GALVANIZED. AT THE CONTRACTOR'S OPTION, STAINLESS STEEL BOLTS AND WASHERS MAY BE USED AS AN ALTERNATE FOR THE 3/4" diameter x 2" GALVANIZED BOLTS AND WASHERS. THEY SHALL CONFORM TO OR EXCEED THE MECHANICAL REQUIREMENTS OF ASTM A307. THE USE OF THIS ALTERNATE SHALL BE APPROVED BY THE ENGINEER.
 - WIRE STRUT SHOWN IN THE CONCRETE ANCHOR ASSEMBLY DETAIL IS THE MINIMUM ALLOWABLE SIZE AND SHALL HAVE A MINIMUM TENSILE STRENGTH OF 100,000 PSI. AS AN OPTION, A 1/16" diameter WIRE STRUT WITH A MINIMUM TENSILE STRENGTH OF 90,000 PSI IS ACCEPTABLE.
 - THE METAL RAIL ANCHOR ASSEMBLIES TO BE HOT DIPPED GALVANIZED TO CONFORM TO REQUIREMENTS OF AASHTO M111.
 - THE COST OF THE METAL RAIL ANCHOR ASSEMBLY WITH BOLTS AND WASHERS COMPLETE IN PLACE SHALL BE INCLUDED IN THE PRICE BID FOR LINEAR FEET OF METAL RAIL.
 - BOLTS TO BE TIGHTENED ONE-HALF TURN WITH A WRENCH FROM A FINGER-TIGHT POSITION.

THE CONTRACTOR MAY USE ADHESIVELY ANCHORED ANCHOR BOLTS IN PLACE OF THE METAL RAIL ANCHOR ASSEMBLY. LEVEL ONE FIELD TESTING IS REQUIRED, AND THE YIELD LOAD OF THE 3/4" diameter BOLT IS 10 KIPS. FOR ADHESIVELY ANCHORED ANCHOR BOLTS OR DOWELS, SEE THE STANDARD SPECIFICATIONS.

WHEN ADHESIVELY ANCHORED ANCHOR BOLTS ARE USED, BOLTS SHALL MEET THE REQUIREMENTS OF ASTM F593 ALLOY 304 STAINLESS STEEL WITH MINIMUM 75,000 PSI ULTIMATE STRENGTH. NUTS SHALL MEET THE REQUIREMENTS OF ASTM F594 ALLOY 304 STAINLESS STEEL AND WASHERS SHALL MEET THE REQUIREMENTS OF ASTM F844 EXCEPT THEY SHALL BE MADE FROM ALLOY 304 STAINLESS STEEL.

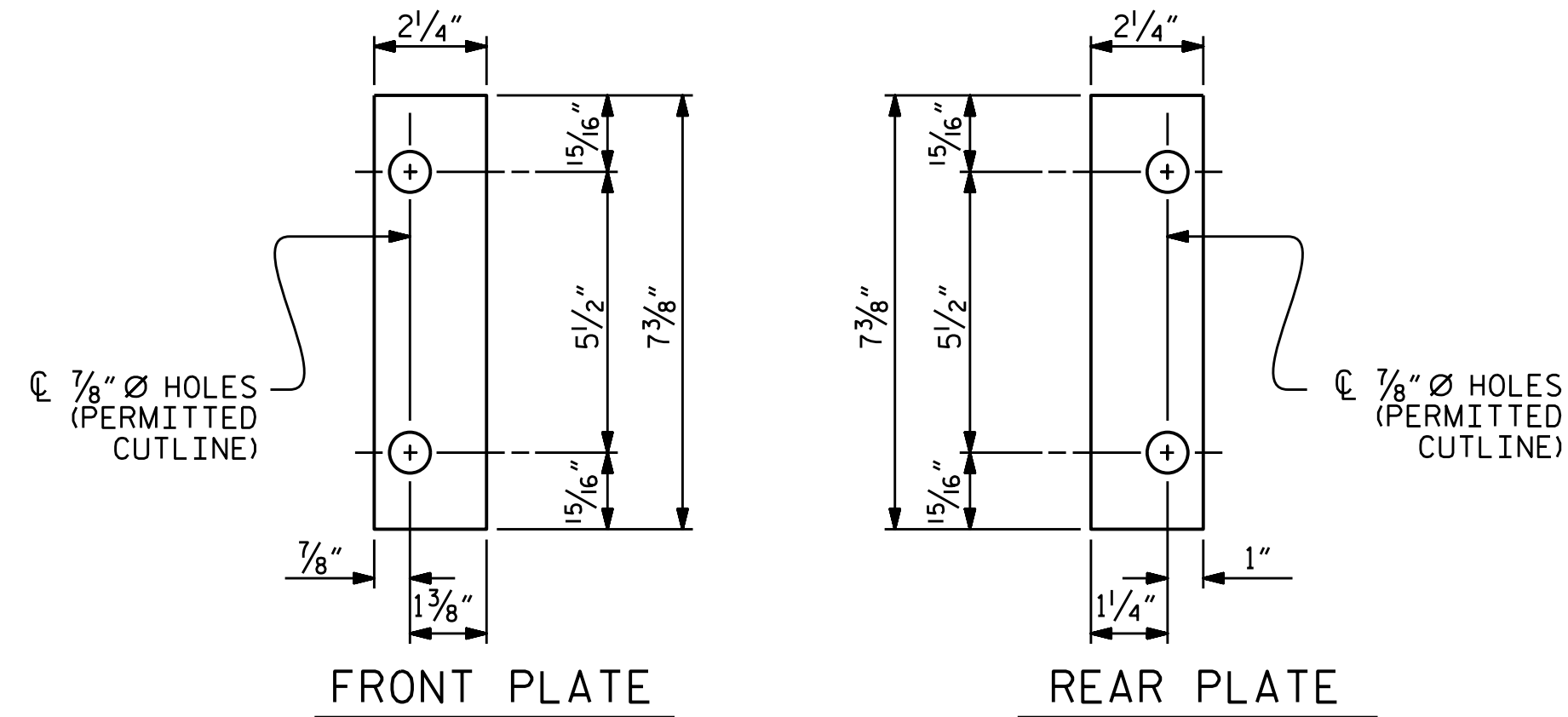
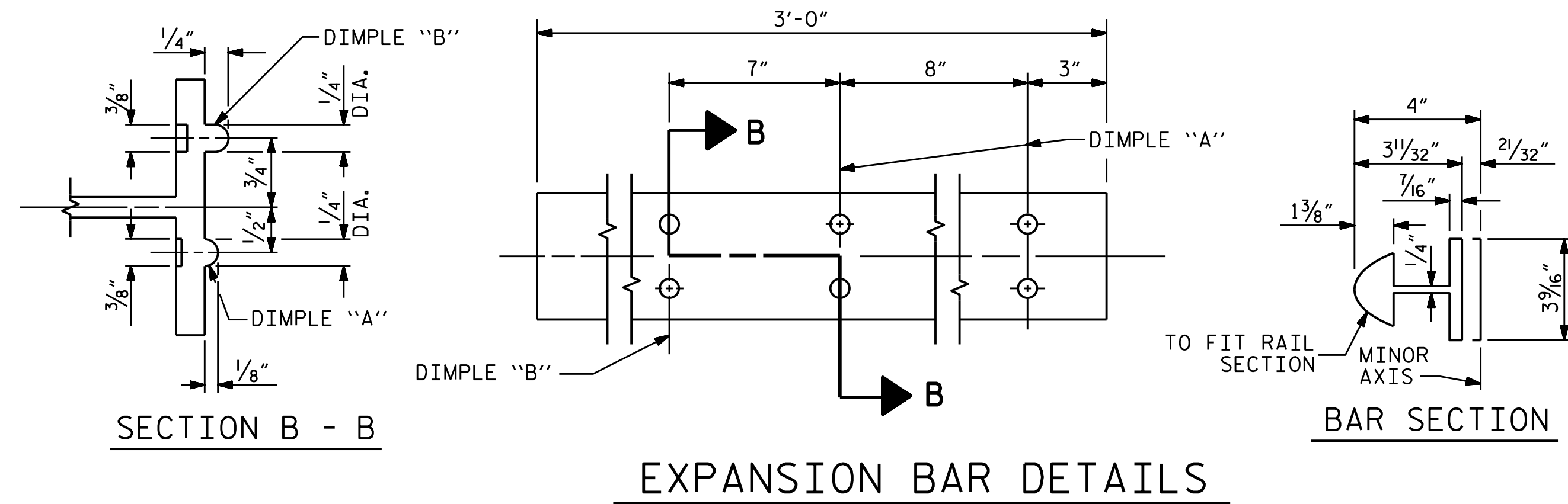

SHIM DETAILS

NOTE: SHIMS MAY BE CUT ALONG PERMITTED CUTLINE OR SLOTTED TO EDGE OF PLATE TO FACILITATE PLACEMENT.

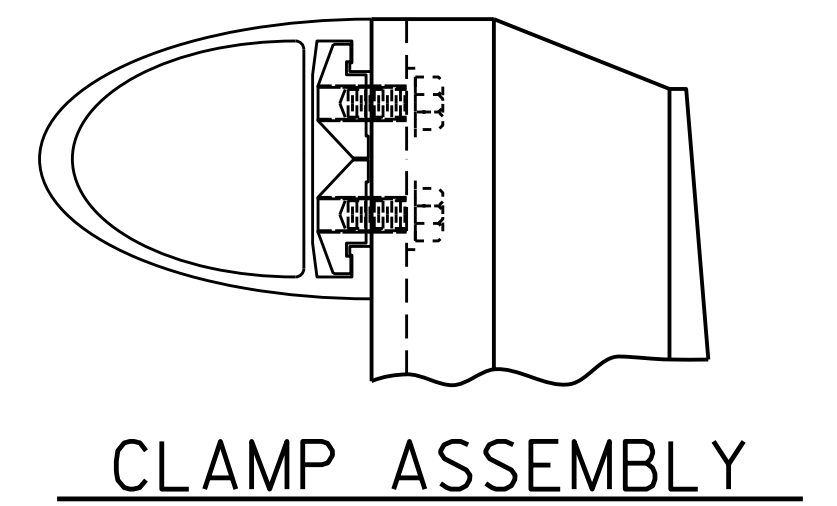
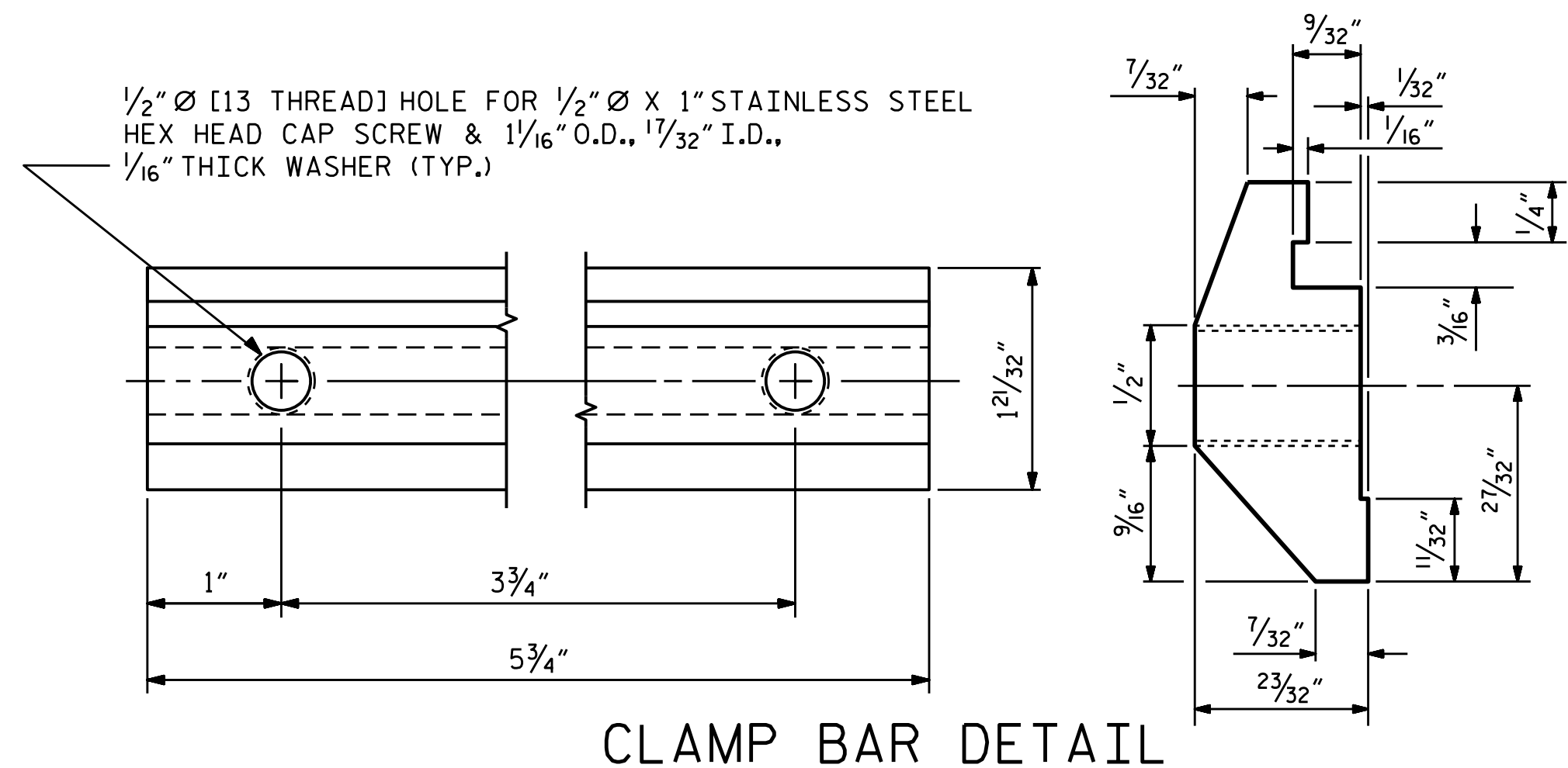

PROJECT NO. U-2579C
FORSYTH COUNTY
 STATION: 21+27.27 -Y2-

SHEET 5 OF 5

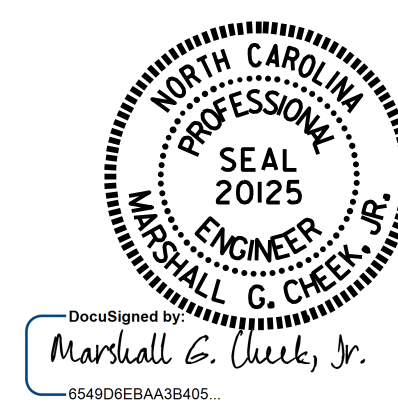

STATE OF NORTH CAROLINA
 DEPARTMENT OF TRANSPORTATION
 RALEIGH
 STANDARD
 2 BAR METAL RAIL

ASSEMBLED BY : N.D'AIUTO	DATE : 1/14/16
CHECKED BY : J.K.BOWLES	DATE : 3/31/16
DRAWN BY : EEM 6/94	REV. 8/16/99 MAB/LES
CHECKED BY : RGW 6/94	REV. 5/1/06R KMM/GM
	REV. 10/1/11 MAA/GM

DOCUMENT NOT CONSIDERED FINAL UNLESS ALL SIGNATURES COMPLETED

REVISIONS						SHEET NO.	
NO.	BY:	DATE:	NO.	BY:	DATE:	S2-19	
1			3			TOTAL SHEETS 30	
2			4				

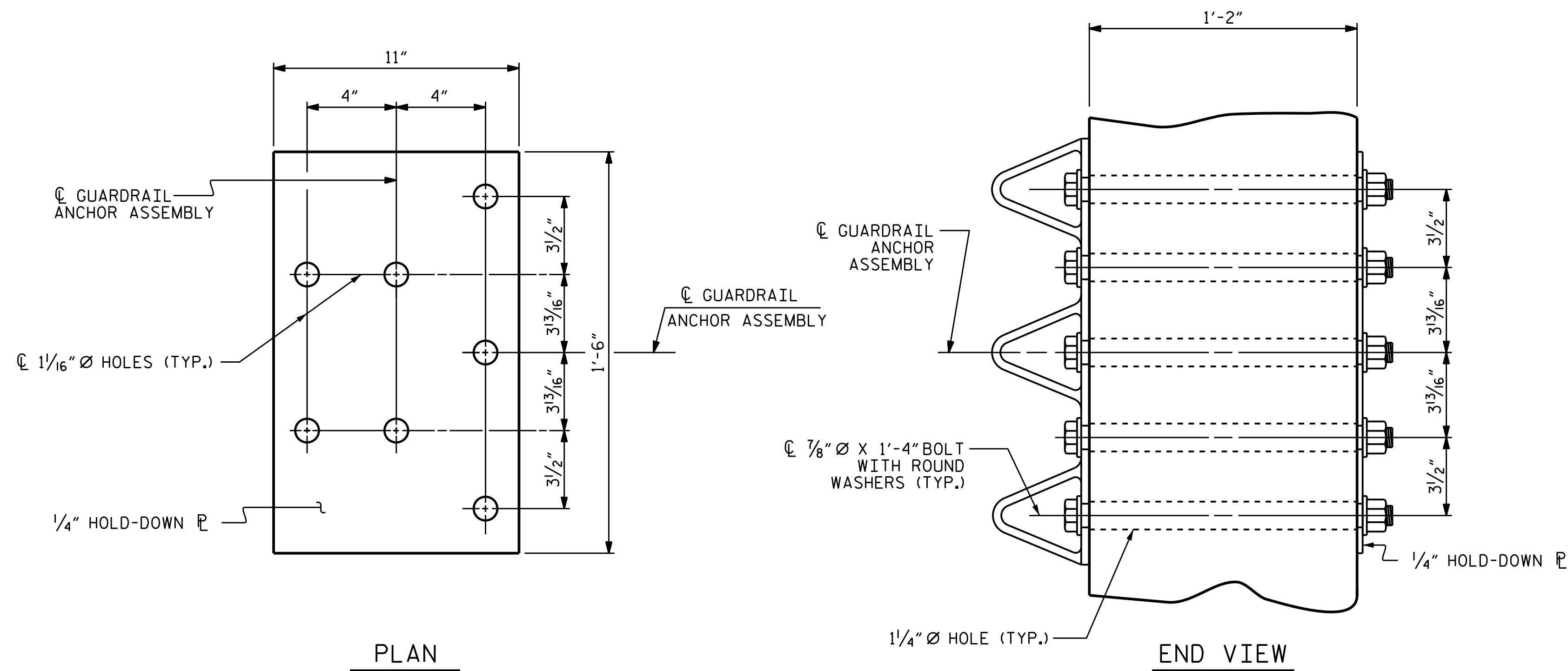

GUARDRAIL ANCHOR ASSEMBLY DETAILS

NOTES

THE GUARDRAIL ANCHOR ASSEMBLY SHALL CONSIST OF A 1/4" HOLD DOWN PLATE AND 7 - 7/8" Ø BOLTS WITH NUTS AND WASHERS.

THE HOLD-DOWN PLATE SHALL CONFORM TO AASHTO M270 GRADE 36. AFTER FABRICATION, THE HOLD-DOWN PLATE SHALL BE HOT-DIP GALVANIZED IN ACCORDANCE WITH AASHTO M111.

BOLTS SHALL CONFORM TO THE REQUIREMENTS OF ASTM A307 AND NUTS SHALL CONFORM TO THE REQUIREMENTS OF AASHTO M291. BOLTS, NUTS AND WASHERS SHALL BE GALVANIZED. AT THE CONTRACTOR'S OPTION, STAINLESS STEEL BOLTS, NUTS AND WASHERS MAY BE USED AS AN ALTERNATE FOR THE 7/8" Ø GALVANIZED BOLTS, NUTS AND WASHERS. THEY SHALL CONFORM TO OR EXCEED THE MECHANICAL REQUIREMENTS OF ASTM A307. THE USE OF THIS ALTERNATE SHALL BE APPROVED BY THE ENGINEER.

THE GUARDRAIL ANCHOR ASSEMBLY IS REQUIRED AT ALL POINTS WHERE APPROACH GUARDRAIL IS TO BE ATTACHED TO THE END OF THE PARAPET. FOR POINTS OF ATTACHMENT, SEE SKETCH.

AFTER INSTALLATION, THE EXPOSED THREAD OF THE BOLT SHALL BE BURRED WITH A SHARP POINTED TOOL.

THE COST OF THE GUARDRAIL ANCHOR ASSEMBLIES WITH BOLTS, NUTS AND WASHERS COMPLETE IN PLACE, SHALL BE INCLUDED IN THE VARIOUS PAY ITEMS.

THE VERTICAL REINFORCING BARS MAY BE SHIFTED SLIGHTLY IN THE END POST TO CLEAR ASSEMBLY BOLTS.

THE 1 1/4" Ø HOLES SHALL BE FORMED OR DRILLED WITH A CORE BIT. IMPACT TOOLS WILL NOT BE PERMITTED. ANY CONCRETE DAMAGED BY THIS WORK SHALL BE REPAIRED TO THE SATISFACTION OF THE ENGINEER.

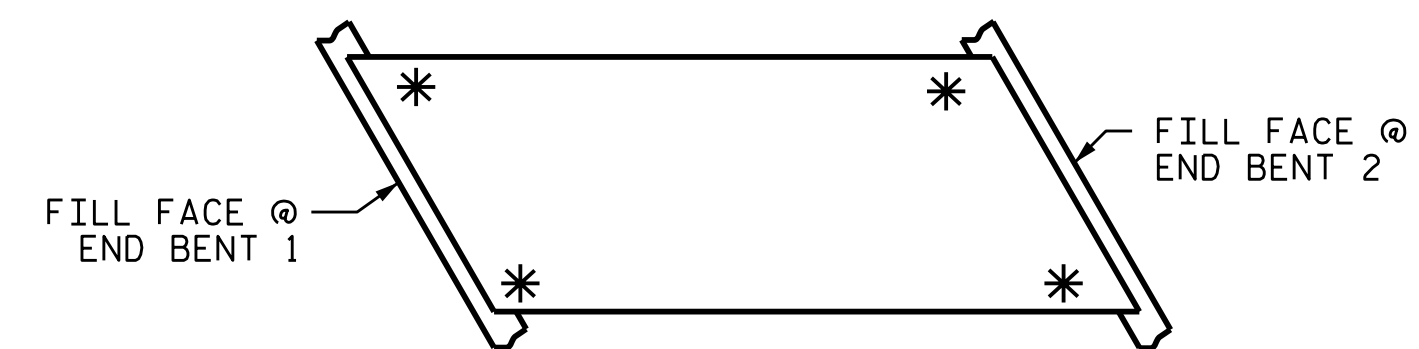

SKETCH SHOWING POINTS OF ATTACHMENT
* LOCATION OF GUARDRAIL ATTACHMENT

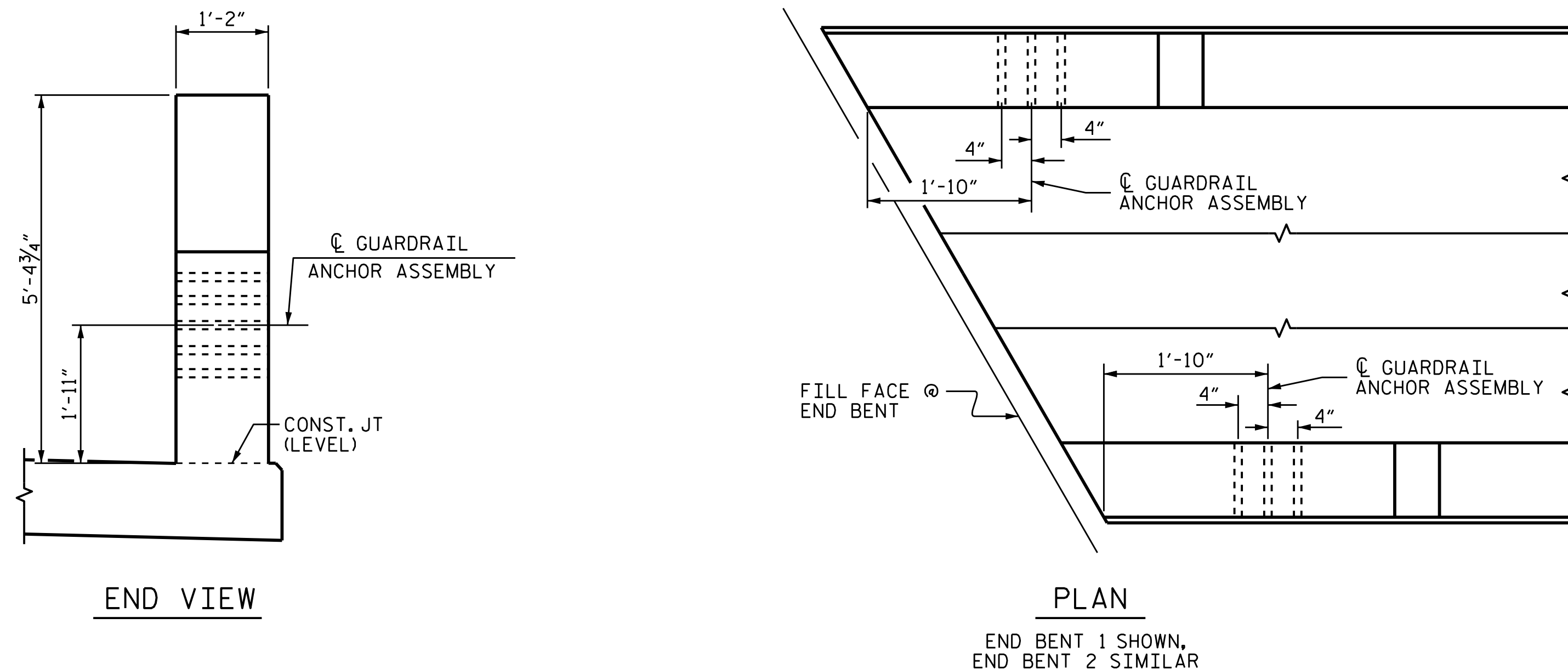

LOCATION OF GUARDRAIL ANCHOR AT END POST

PROJECT NO. U-2579C
FORSYTH COUNTY
 STATION: 21+27.27 -Y2-

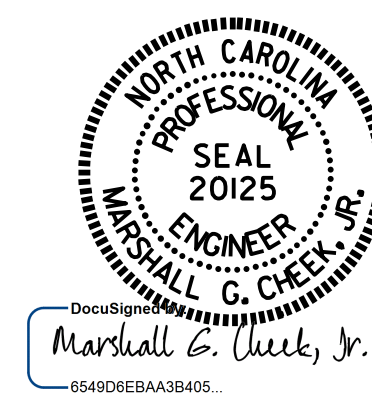

STATE OF NORTH CAROLINA
 DEPARTMENT OF TRANSPORTATION
 RALEIGH
 STANDARD
 GUARDRAIL ANCHORAGE
 DETAILS
 FOR METAL RAILS

ASSEMBLED BY :	N.D'AIUTO	DATE :	1/26/16
CHECKED BY :	J.K.BOWLES	DATE :	3/31/16
DRAWN BY :	MAA	5/10	REV. 12/5/11
CHECKED BY :	GM	5/10	REV. 6/13
			REV. 1/15

DOCUMENT NOT CONSIDERED FINAL UNLESS ALL SIGNATURES COMPLETED

REVISIONS						SHEET NO.
NO.	BY:	DATE:	NO.	BY:	DATE:	S2-20
1			3			TOTAL SHEETS 30
2			4			

BAR TYPES

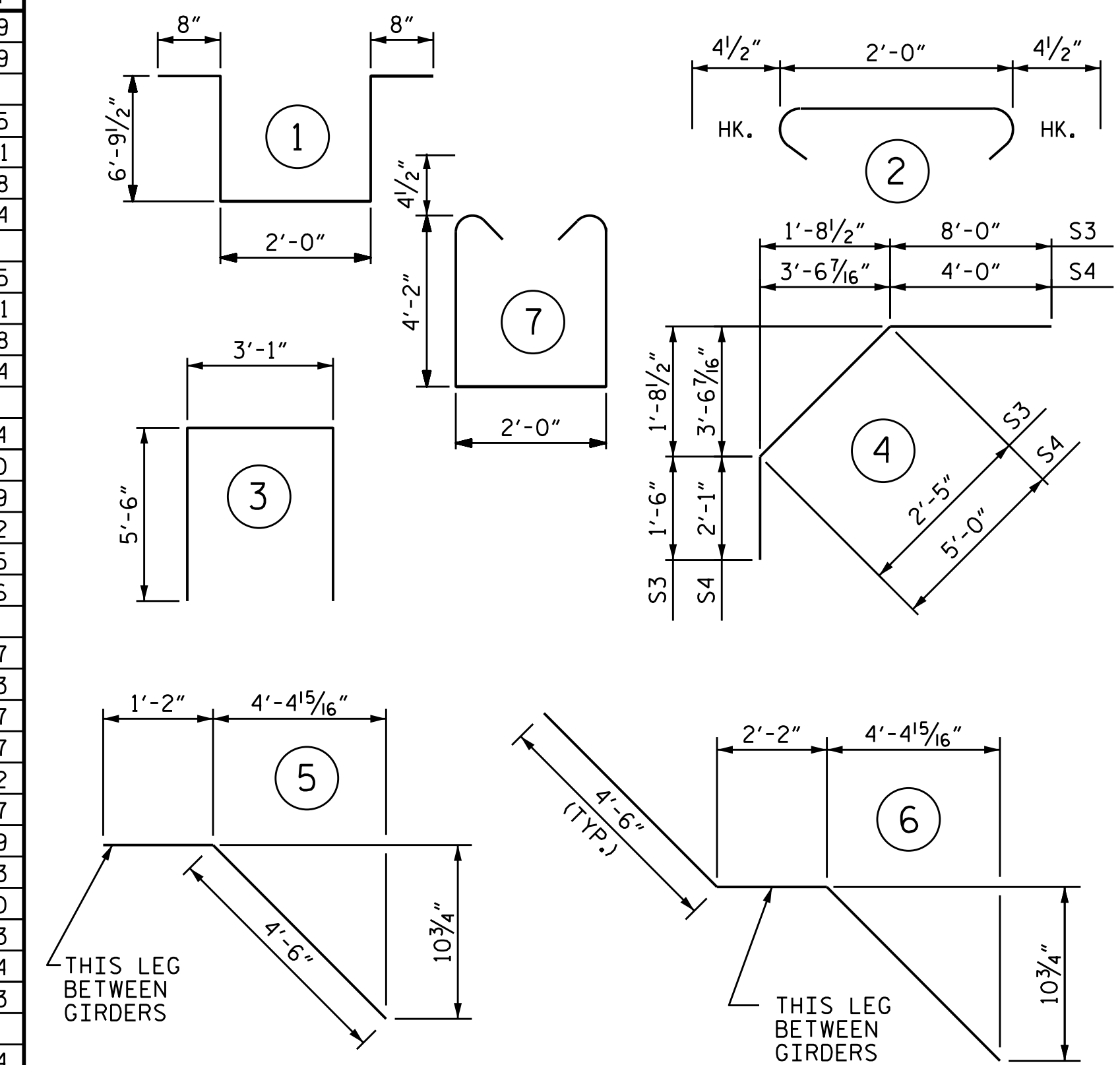

ALL BAR DIMENSIONS ARE OUT TO OUT.

REINFORCING BAR SCHEDULE

BAR	NO.	SIZE	TYPE	LENGTH	WEIGHT
* A1	342	#5	STR	36'-9"	13109
A2	342	#5	STR	36'-9"	13109
* A101	4	#5	STR	29'-11"	125
* A102	4	#5	STR	21'-11"	91
* A103	4	#5	STR	13'-10"	58
* A104	4	#5	STR	5'-9"	24
A201	4	#5	STR	29'-11"	125
A202	4	#5	STR	21'-11"	91
A203	4	#5	STR	13'-10"	58
A204	4	#5	STR	5'-9"	24
* B1	8	#5	STR	56'-9"	474
* B2	194	#5	STR	22'-7"	4570
* B3	100	#4	STR	29'-4"	1959
* B4	98	#5	STR	37'-0"	3782
* B5	48	#5	STR	33'-3"	1665
B6	116	#5	STR	56'-6"	6836
K1	32	#4	STR	19'-6"	417
K2	12	#4	STR	5'-4"	43
K3	6	#4	STR	6'-10"	27
K4	60	#4	STR	8'-5"	337
K5	6	#4	STR	7'-11"	32
K6	4	#4	STR	2'-6"	7
K7	4	#4	STR	3'-3"	9
K8	20	#4	STR	4'-0"	53
K9	4	#4	STR	3'-10"	10
K10	6	#4	STR	5'-10"	23
K11	14	#4	6	11'-2"	104
K12	14	#4	5	5'-8"	53
S1	138	#4	2	2'-9"	254
S2	44	#4	3	14'-1"	414
* S3	48	#4	4	11'-11"	382
* S4	48	#4	4	11'-1"	355
U1	18	#4	1	16'-1"	193
U2	6	#4	7	11'-1"	44
REINFORCING STEEL				LBS.	22,263
* EPOXY COATED REINFORCING STEEL				LBS.	26,594

— SUPERSTRUCTURE BILL OF MATERIAL —

	CLASS AA CONCRETE (CU. YDS.)	REINFORCING STEEL (LBS.)	EPOXY COATED REINFORCING STEEL (LBS.)
POUR #1	117.4		
POUR #2	155.5	22,263	26,594
POUR #3	71.4		
TOTALS**	344.3	22,263	26,594

**QUANTITIES FOR PARAPET AND END POSTS ARE NOT INCLUDED

GROOVING BRIDGE FLOORS

APPROACH SLABS	736 SQ.FT.
BRIDGE DECK	5,706 SQ.FT.
TOTAL	6,442 SQ.FT.

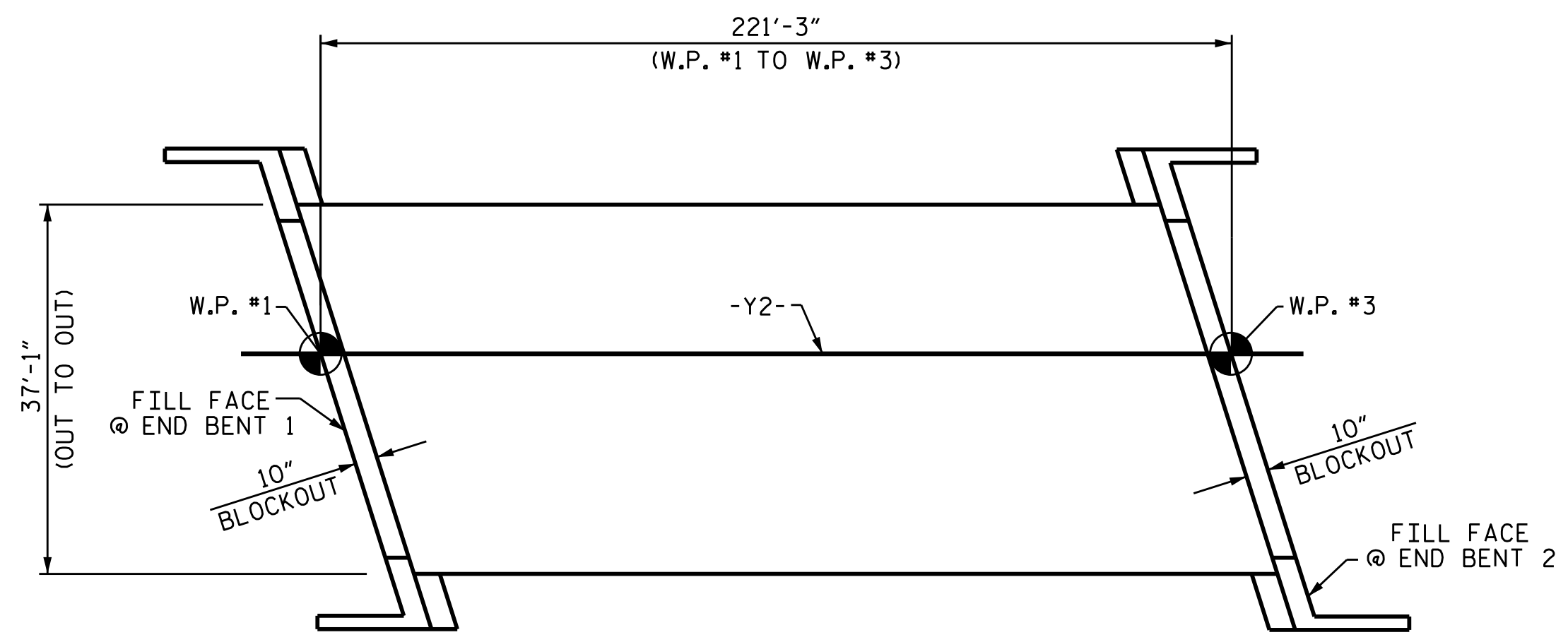

LAYOUT FOR COMPUTING AREA REINFORCED CONCRETE DECK SLAB (SQ. FT. = 8,205)

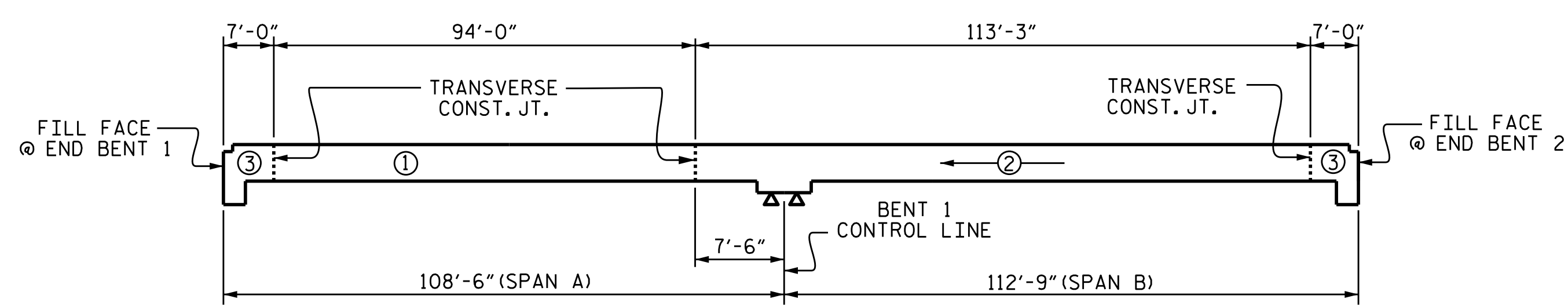

POUR SEQUENCE

③ = INDICATES POUR NUMBER AND DIRECTION OF POUR

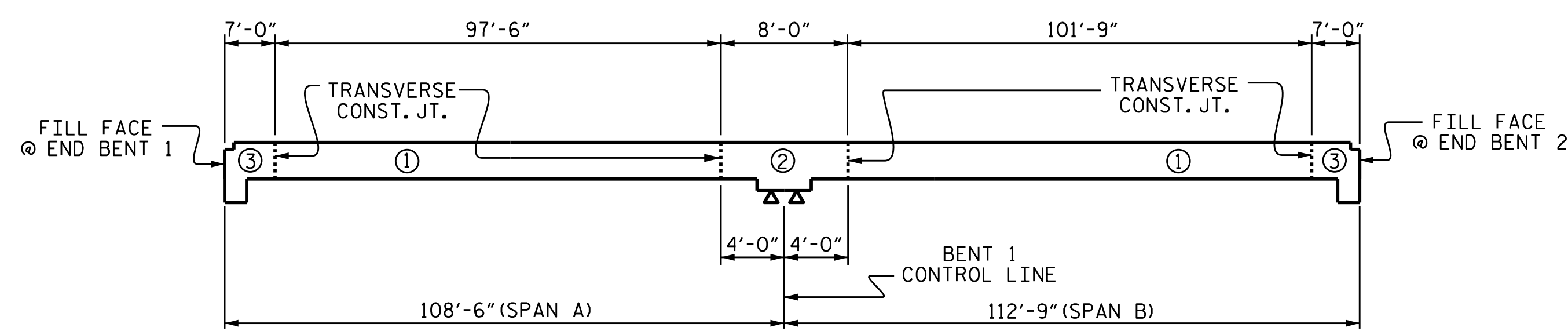

OPTIONAL POUR SEQUENCE

POUR ② CAN NOT BE STARTED UNTIL BOTH ADJACENT ①POURS REACH A MINIMUM OF 3,000 PSI.

SUPERSTRUCTURE REINFORCING STEEL LENGTHS ARE BASED ON THE FOLLOWING MINIMUM SPLICE LENGTHS

BAR SIZE	SUPERSTRUCTURE EXCEPT APPROACH SLABS, PARAPET, AND BARRIER RAIL		APPROACH SLABS		PARAPET AND BARRIER RAIL
	EPOXY COATED	UNCOATED	EPOXY COATED	UNCOATED	
#4	2'-0"	1'-9"	2'-0"	1'-9"	2'-9"
#5	2'-6"	2'-2"	2'-6"	2'-2"	3'-5"
#6	3'-0"	2'-7"	3'-10"	2'-7"	4'-4"
#7	5'-3"	3'-6"			
#8	6'-10"	4'-7"			

PROJECT NO. U-2579C
 FORSYTH COUNTY
 STATION: 21+27.27 -Y2-



STATE OF NORTH CAROLINA
 DEPARTMENT OF TRANSPORTATION
 RALEIGH
 SUPERSTRUCTURE
 BILL OF MATERIAL

DRAWN BY : N.D'AIUTO DATE: 1/26/16
 CHECKED BY : J.K.BOWLES DATE: 3/31/16
 DESIGN ENGINEER OF RECORD : J.K.BOWLES DATE: 3/31/16

DOCUMENT NOT CONSIDERED FINAL UNLESS ALL SIGNATURES COMPLETED

REVISIONS						SHEET NO.
NO.	BY:	DATE:	NO.	BY:	DATE:	S2-21
1			3			TOTAL SHEETS 30
2			4			

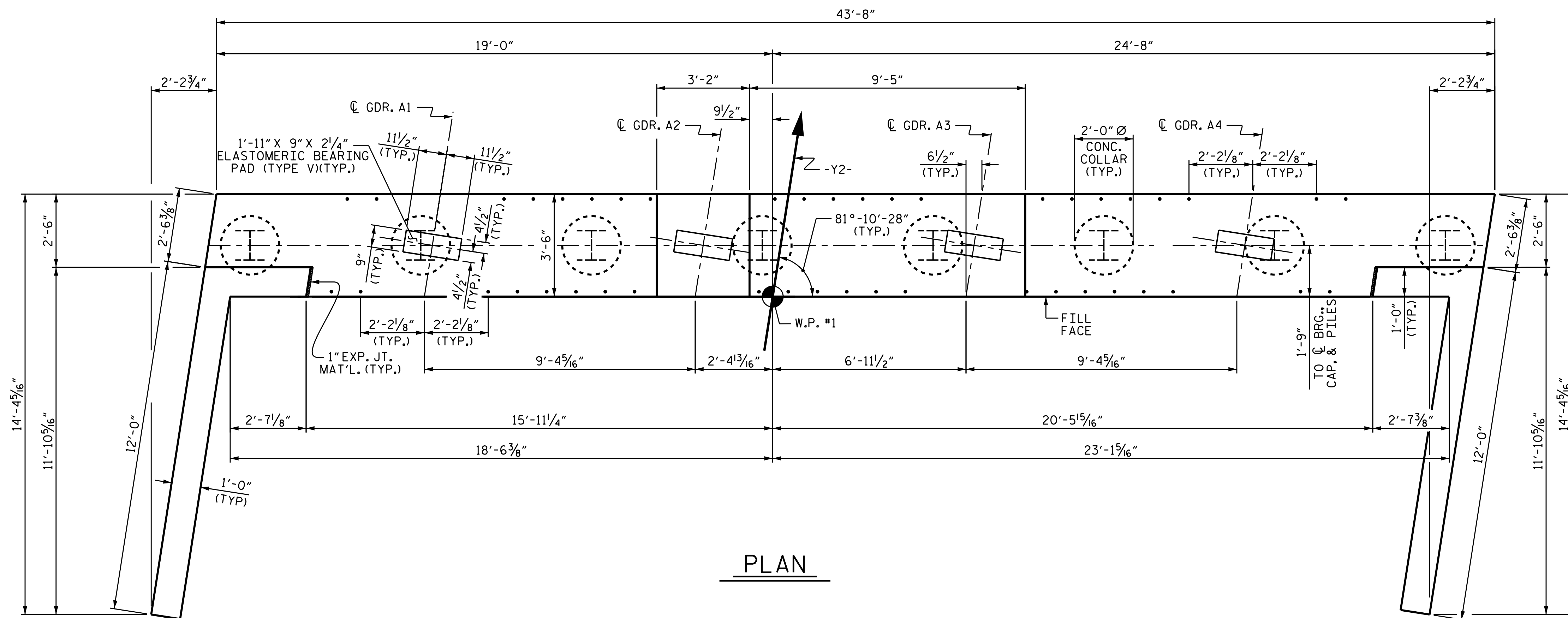

NOTES

THE TOP SURFACE OF THE END BENT CAP, EXCEPT THE BEARING AREA, SHALL BE RAKED TO A DEPTH OF 1/4".

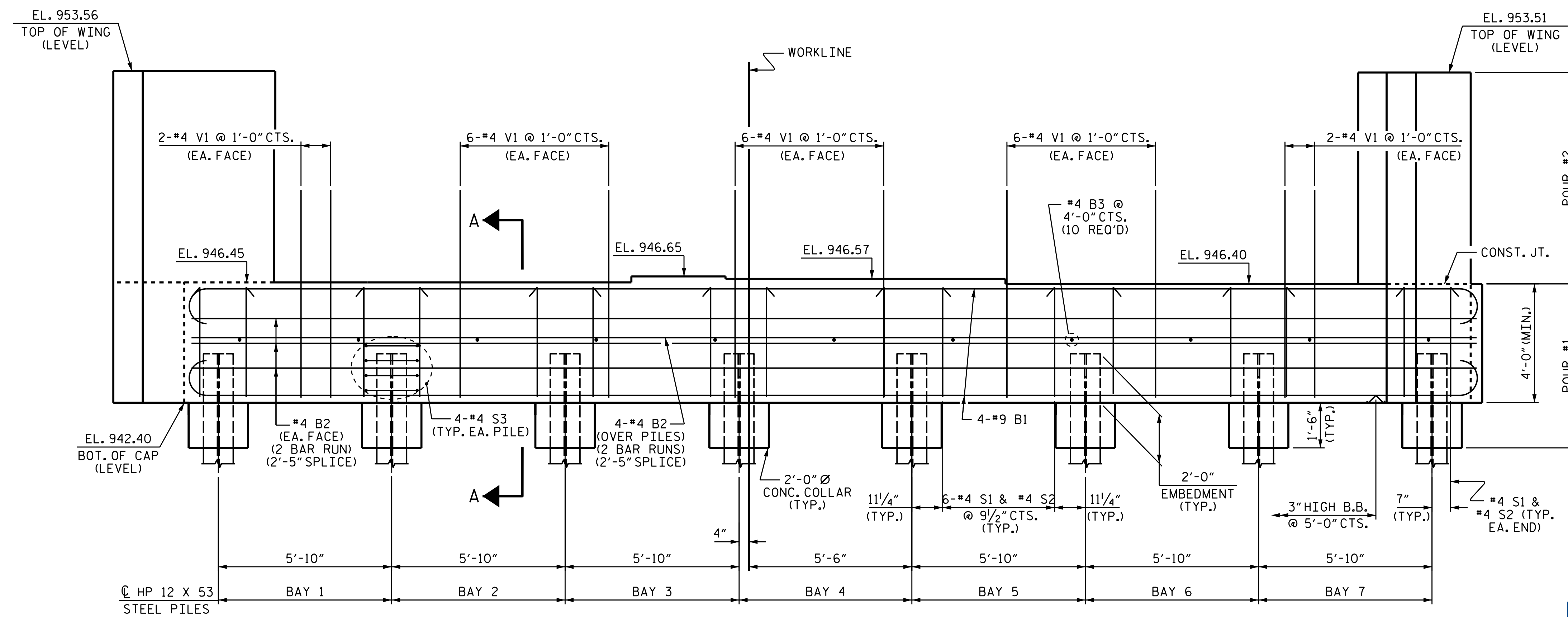

PROJECT NO. U-2579C
FORSYTH COUNTY
 STATION: 21+27.27 -Y2-

SHEET 1 OF 2



STATE OF NORTH CAROLINA
 DEPARTMENT OF TRANSPORTATION
 RALEIGH

**SUBSTRUCTURE
 INTEGRAL
 END BENT 1**

DRAWN BY : J. K. BOWLES DATE : 5/10/16
 CHECKED BY : K. D. LAYNE DATE : 7/21/16
 DESIGN ENGINEER OF RECORD : J. K. BOWLES DATE : 7/21/16

DOCUMENT NOT CONSIDERED
 FINAL UNLESS ALL
 SIGNATURES COMPLETED

REVISIONS						SHEET NO.
NO.	BY:	DATE:	NO.	BY:	DATE:	S2-22
1			3			TOTAL SHEETS
2			4			30

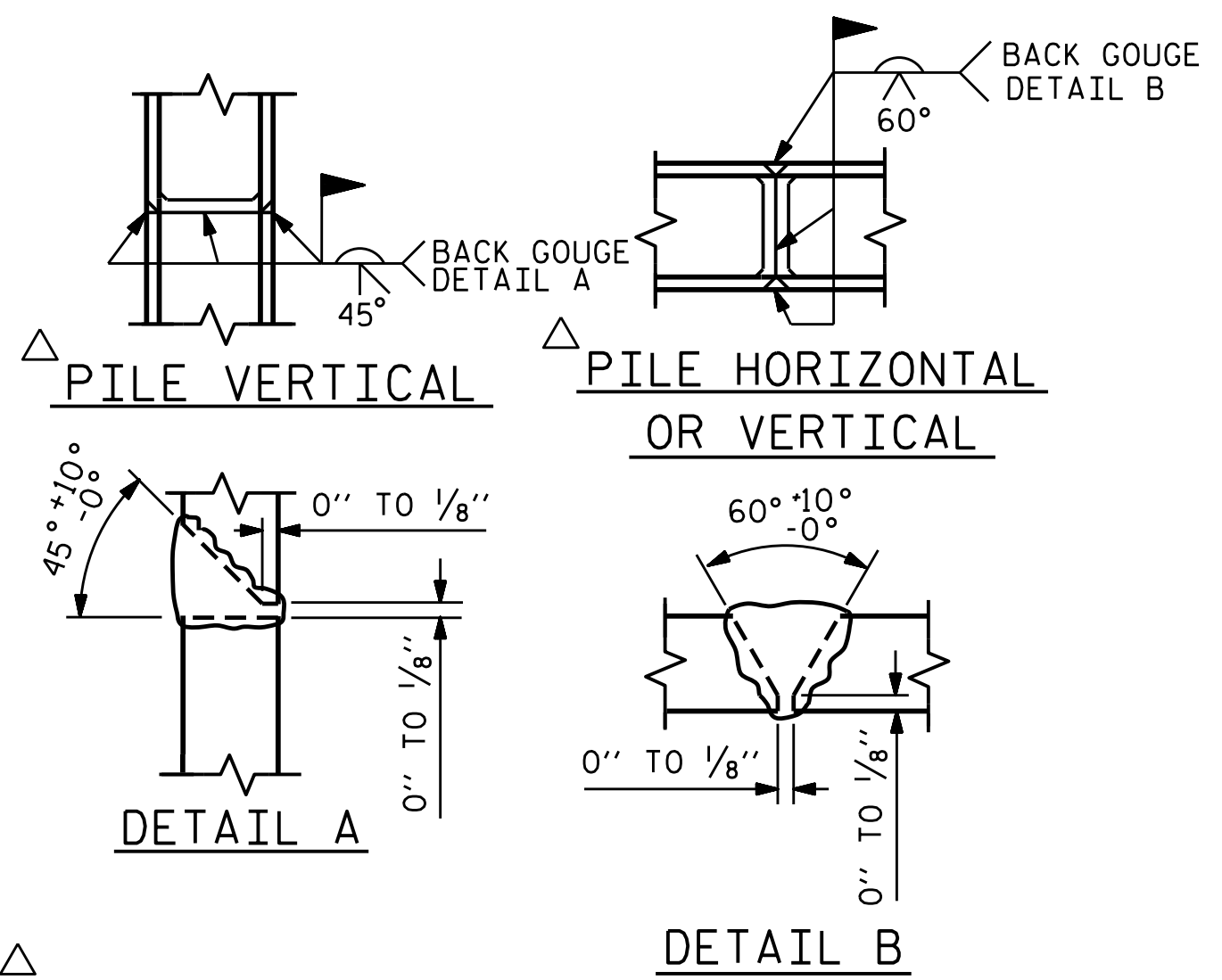

POSITION OF PILE DURING WELDING.
PILE SPLICE DETAILS

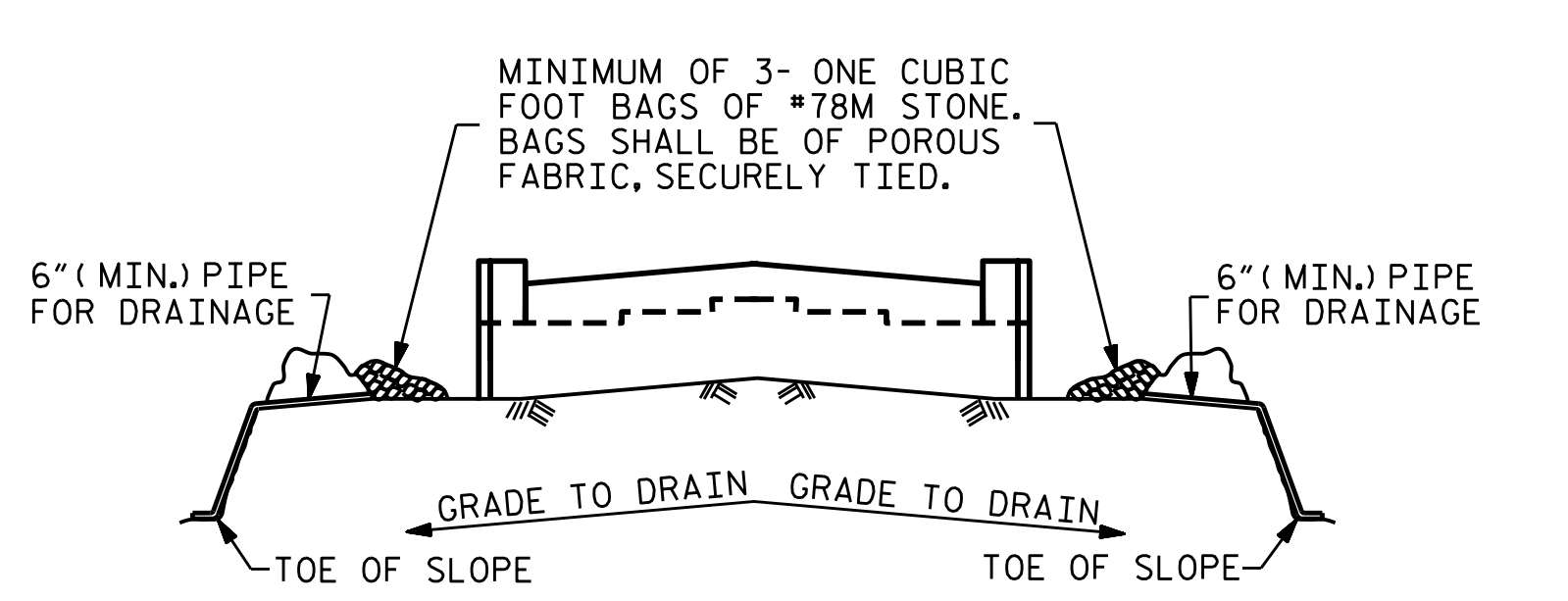

BAGGED STONE AND PIPE SHALL BE PLACED IMMEDIATELY AFTER COMPLETION OF END BENT EXCAVATION. PIPE MAY BE EITHER CONCRETE, CORRUGATED STEEL, CORRUGATED ALUMINUM ALLOY, OR CORRUGATED PLASTIC. PERFORATED PIPE WILL NOT BE ALLOWED.

BAGGED STONE SHALL REMAIN IN PLACE UNTIL THE ENGINEER DIRECTS THAT IT BE REMOVED. THE CONTRACTOR SHALL REMOVE AND DISPOSE OF SILT ACCUMULATIONS AT BAGGED STONE WHEN SO DIRECTED BY THE ENGINEER. BAGS SHALL BE REMOVED AND REPLACED WHENEVER THE ENGINEER DETERMINES THAT THEY HAVE DETERIORATED AND LOST THEIR EFFECTIVENESS.

NO SEPARATE PAYMENT WILL BE MADE FOR THIS WORK AND THE ENTIRE COST OF THIS WORK SHALL BE INCLUDED IN THE UNIT CONTRACT PRICE BID FOR THE SEVERAL PAY ITEMS.

TEMPORARY DRAINAGE AT END BENT

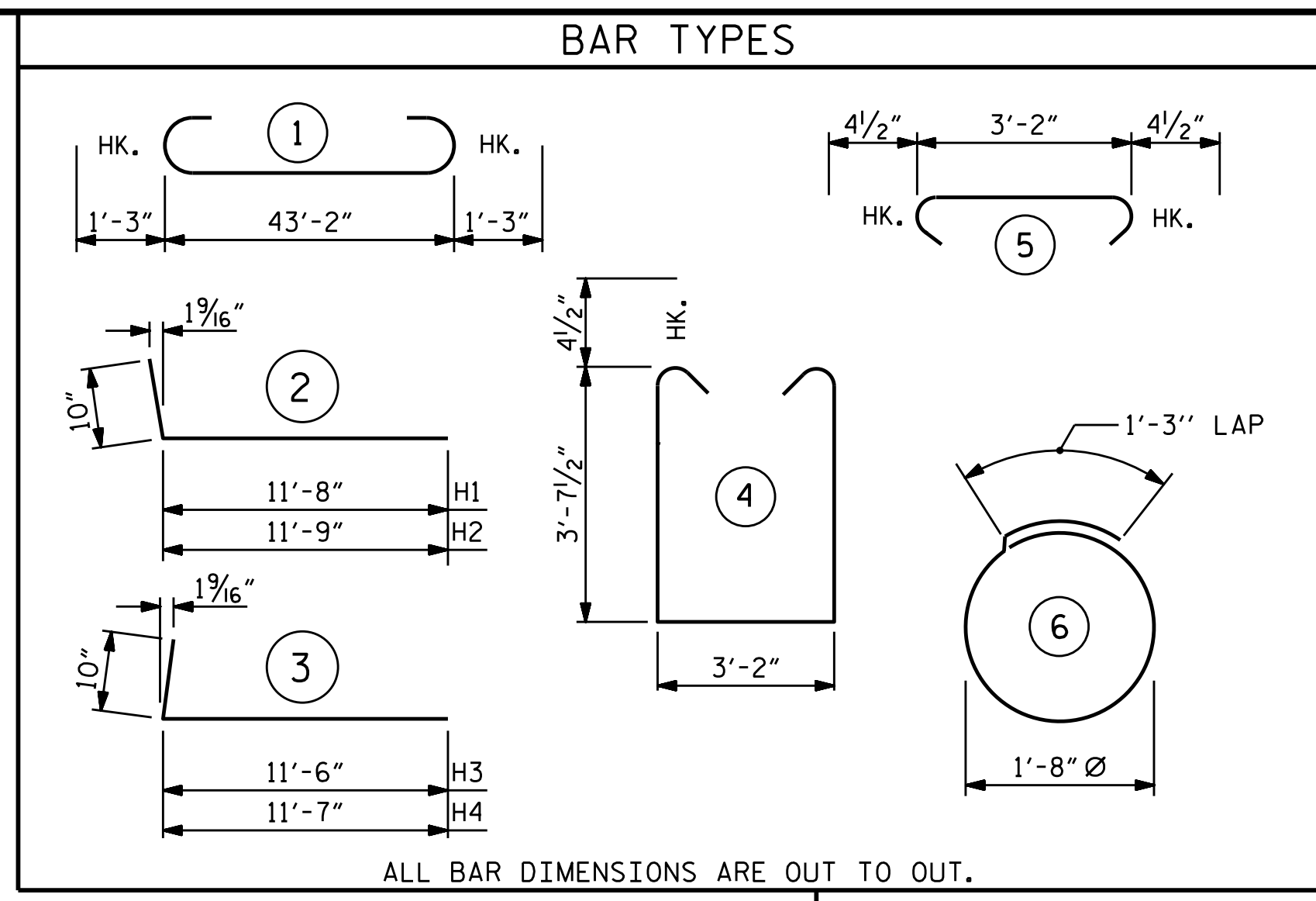

ALL BAR DIMENSIONS ARE OUT TO OUT.

PILE DRIVING EQUIPMENT SETUP FOR HP 12 X 53 STEEL PILES 8 EA.

BILL OF MATERIAL					
END BENT 1					
BAR	NO.	SIZE	TYPE	LENGTH	WEIGHT
B1	8	#9	1	45'-8"	1242
B2	20	#4	STR	22'-11"	306
B3	10	#4	STR	3'-2"	21
H1	22	#5	2	12'-6"	287
H2	22	#5	2	12'-7"	289
H3	22	#5	3	12'-4"	283
H4	22	#5	3	12'-5"	285
K1	28	#4	STR	3'-3"	61
S1	44	#4	4	11'-2"	328
S2	44	#4	5	3'-11"	115
S3	32	#4	6	6'-6"	139
V1	44	#4	STR	6'-3"	184
V2	64	#5	STR	10'-9"	718
REINFORCING STEEL				LBS.	4,258
CLASS A CONCRETE					
POUR #1 CAP, LOWER PART OF WINGS, & COLLARS				C.Y.	27.7
POUR #2 UPPER PART OF WINGS				C.Y.	6.9
TOTAL				C.Y.	34.6
HP 12 X 53 STEEL PILES					
NO.: 8				LIN. FT.	360

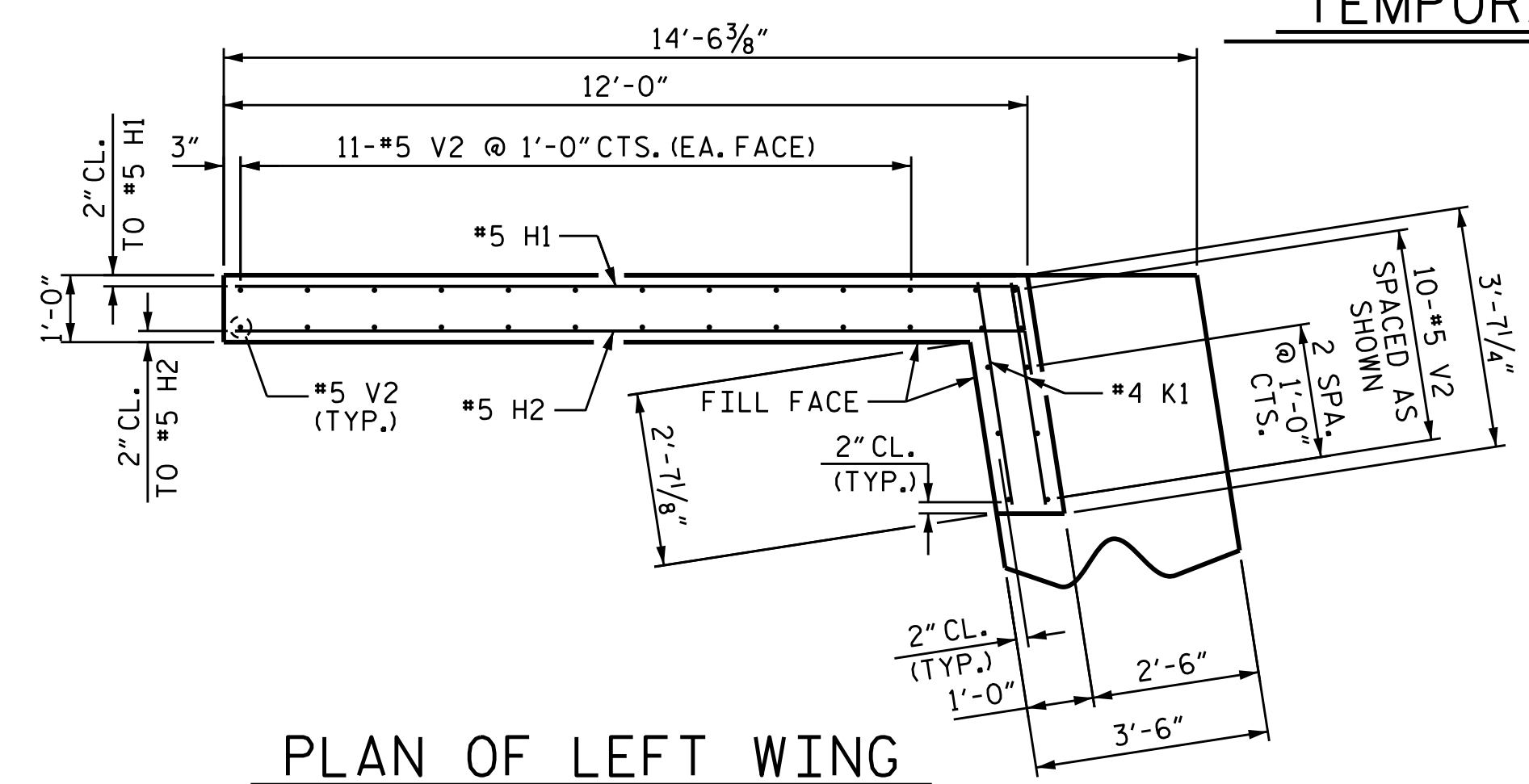

PLAN OF LEFT WING

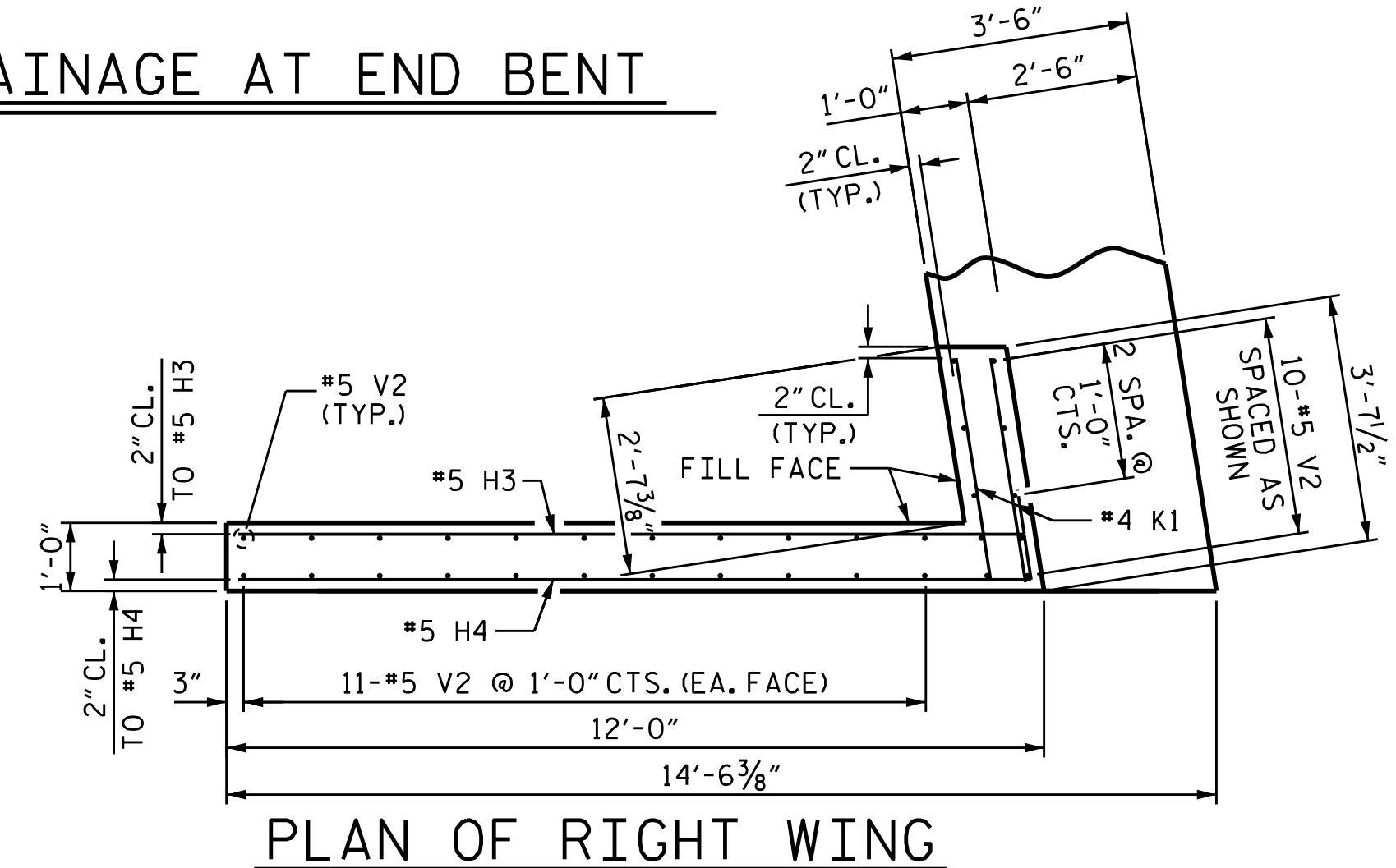

PLAN OF RIGHT WING

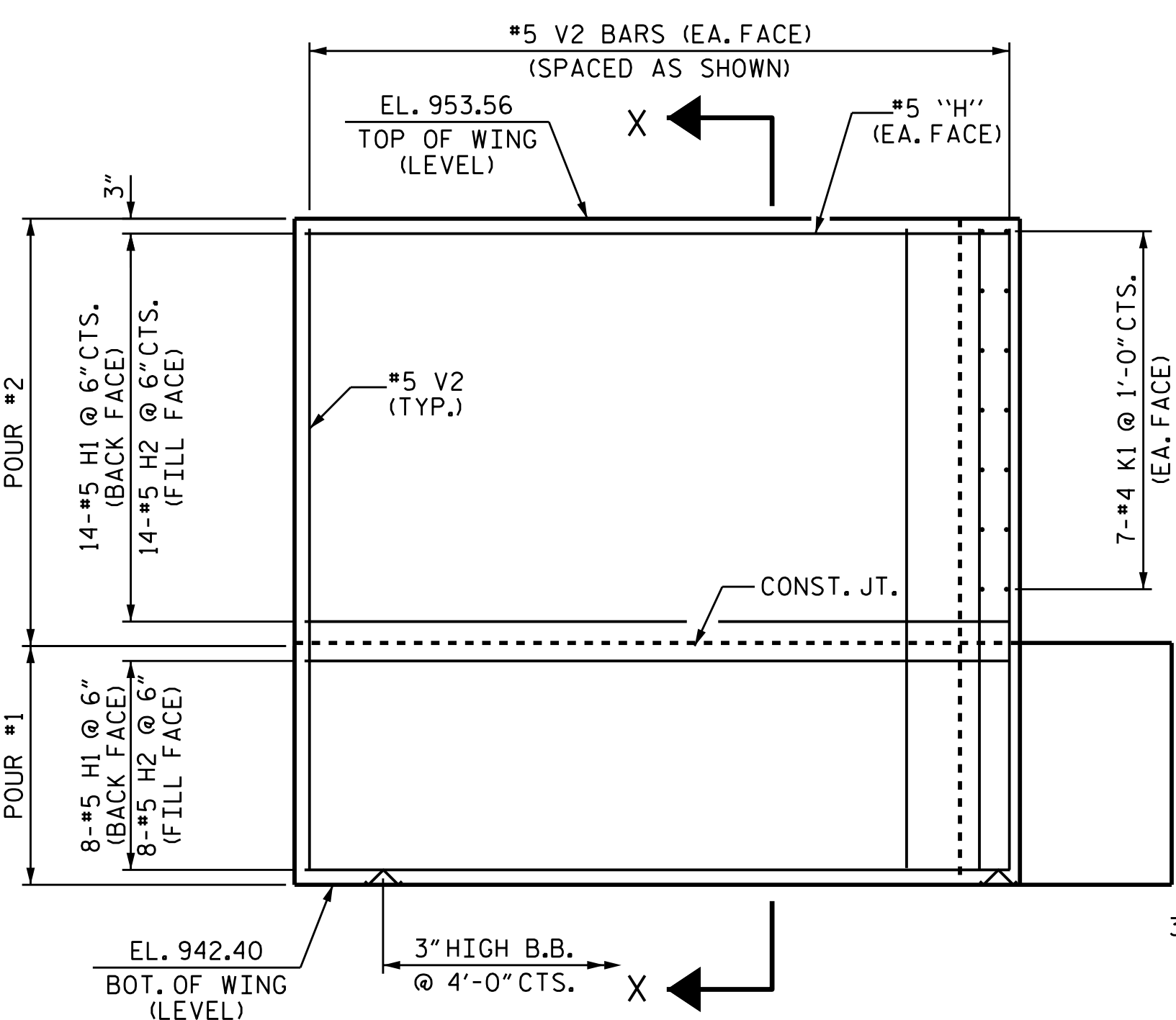

ELEVATION OF LEFT WING

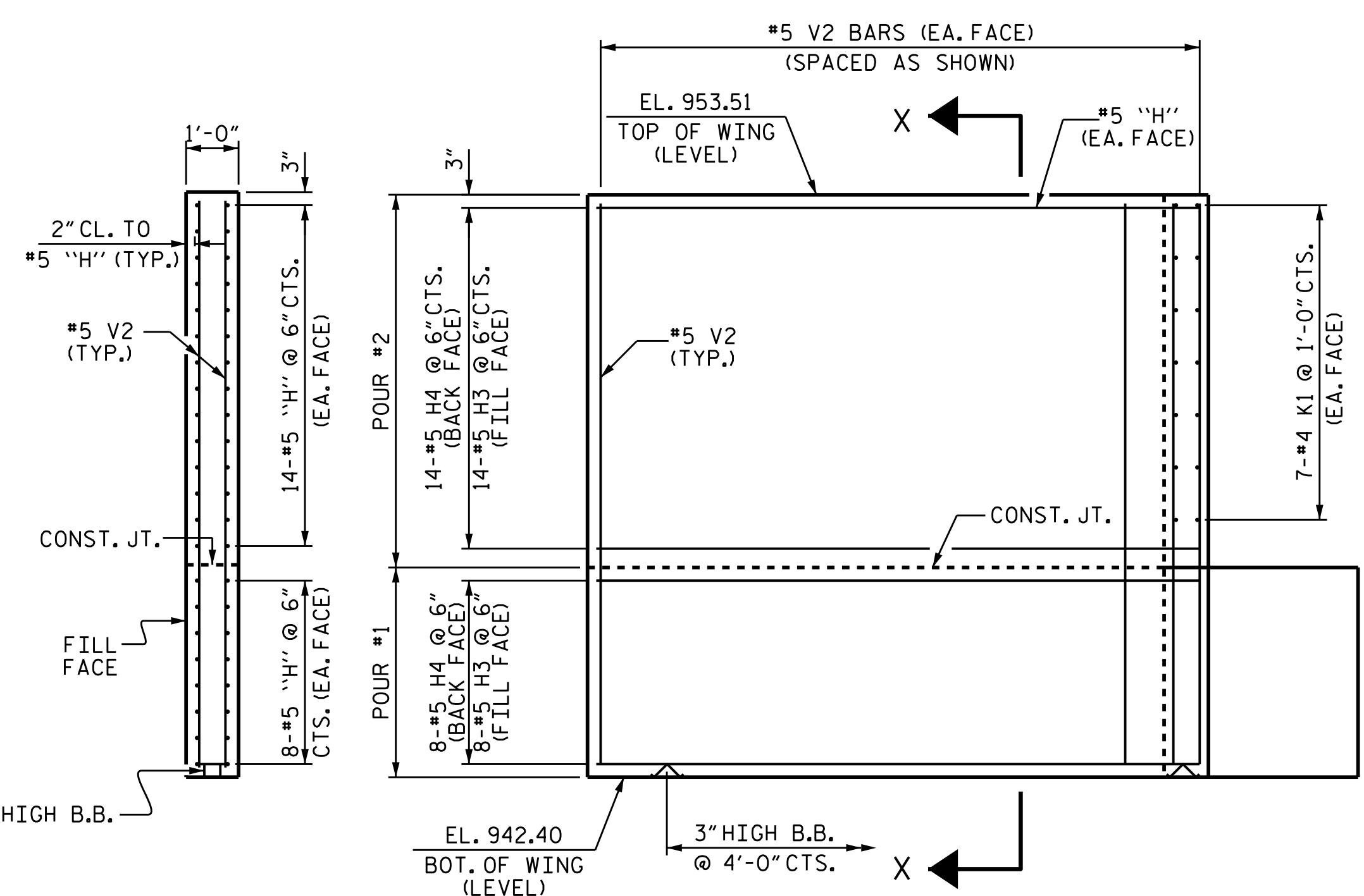

ELEVATION OF RIGHT WING

SECTION X-X

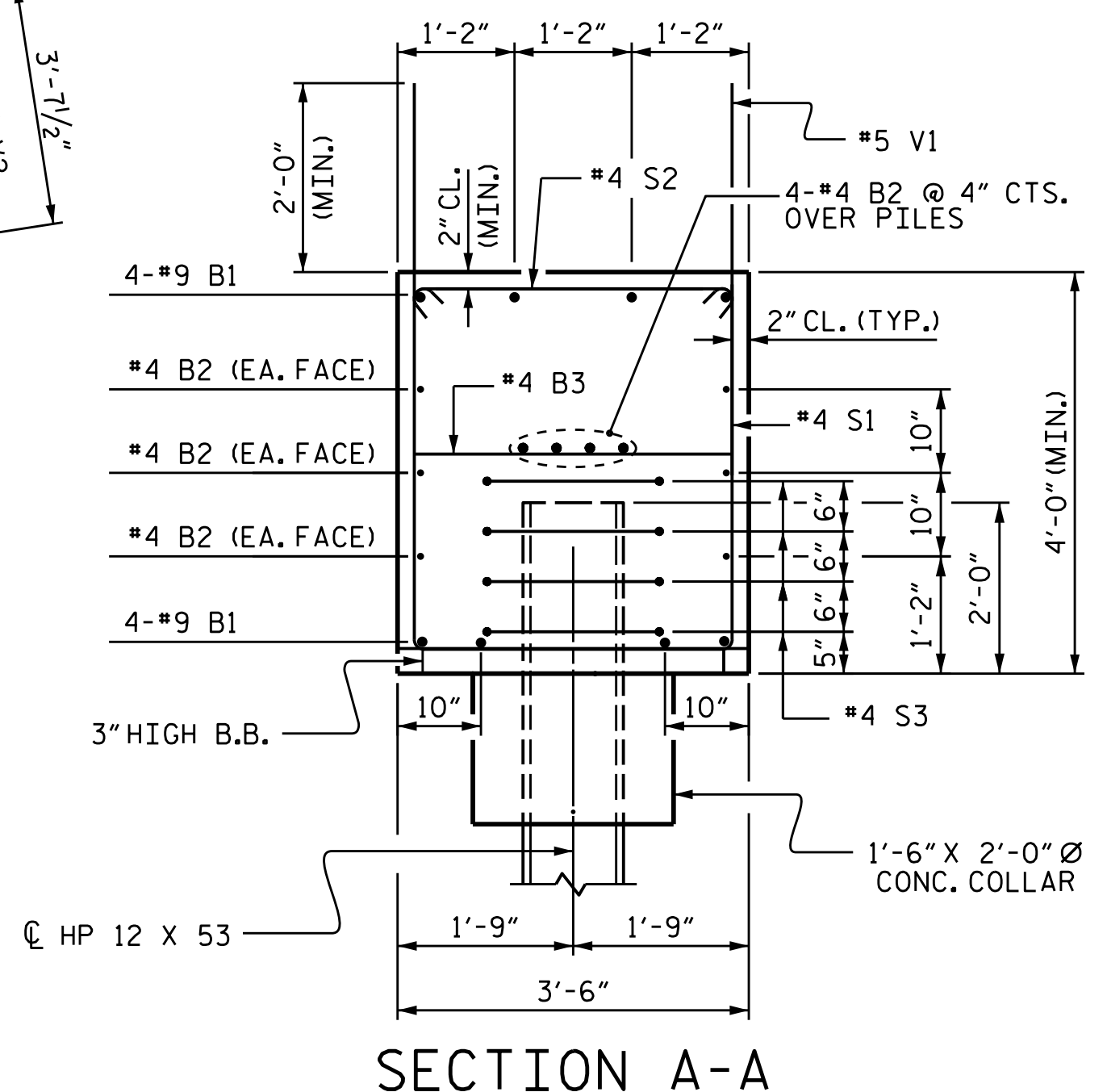

SECTION A-A

PROJECT NO. U-2579C
 FORSYTH COUNTY
 STATION: 21+27.27 -Y2-

SHEET 2 OF 2



STATE OF NORTH CAROLINA
 DEPARTMENT OF TRANSPORTATION
 RALEIGH
 SUBSTRUCTURE
 INTEGRAL
 END BENT 1

DRAWN BY: J. K. BOWLES DATE: 5/10/16
 CHECKED BY: K. D. LAYNE DATE: 7/21/16
 DESIGN ENGINEER OF RECORD: J. K. BOWLES DATE: 7/21/16

DOCUMENT NOT CONSIDERED FINAL UNLESS ALL SIGNATURES COMPLETED

REVISIONS						SHEET NO.
NO.	BY:	DATE:	NO.	BY:	DATE:	S2-23
1			3			TOTAL SHEETS
2			4			30

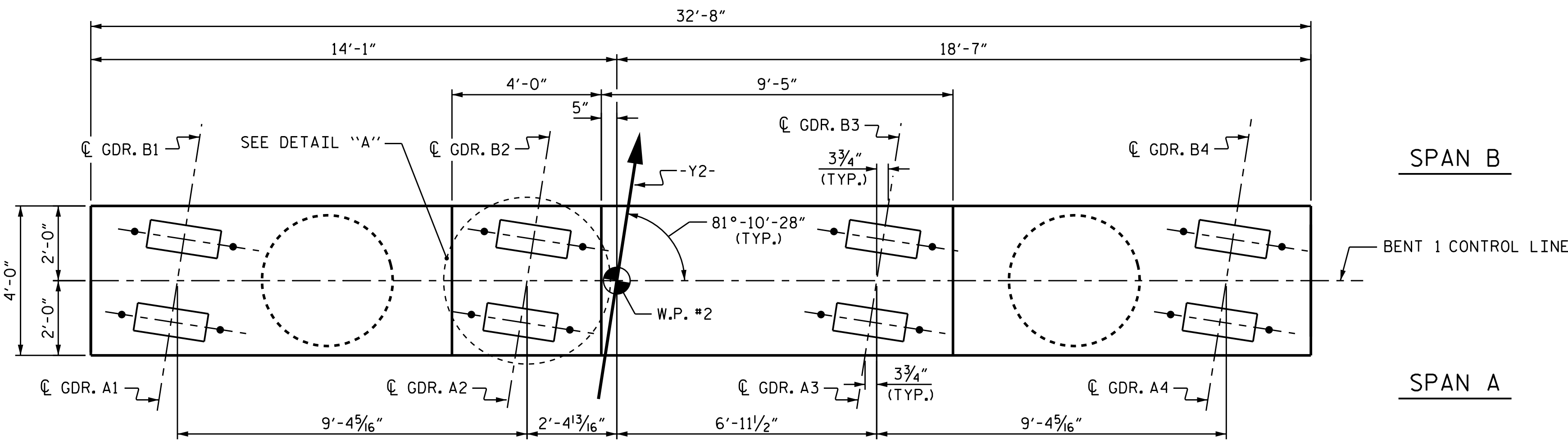

PLAN

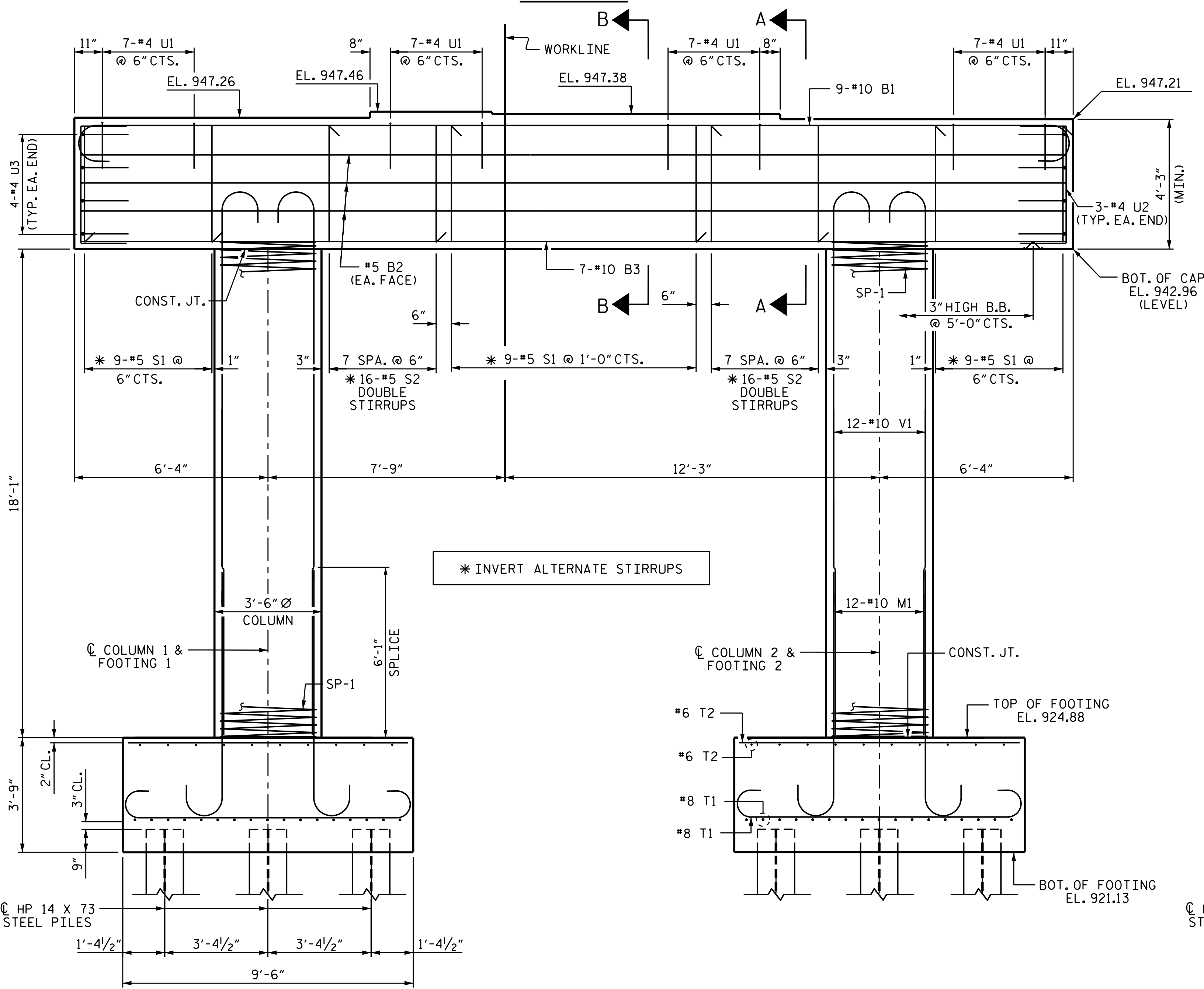

ELEVATION

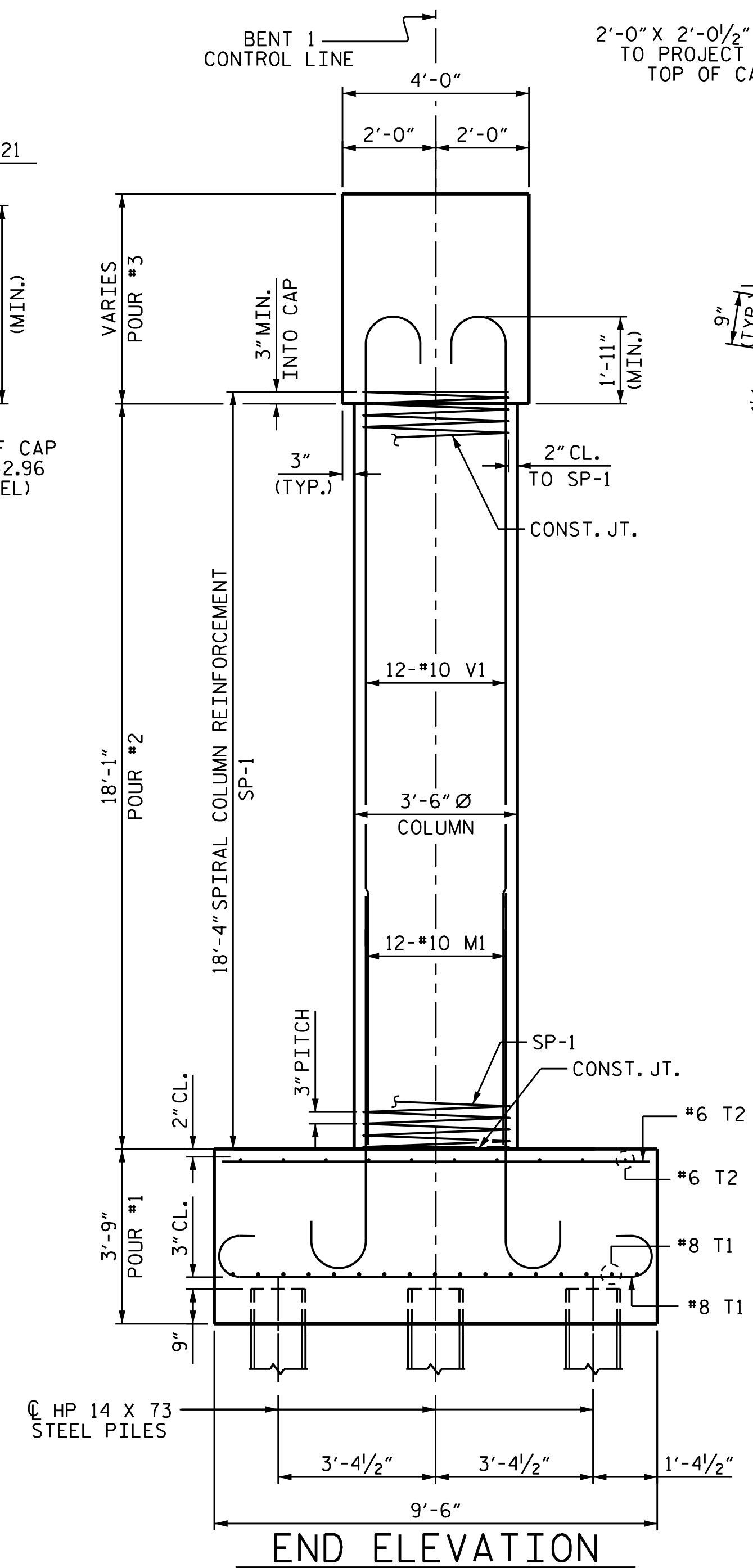

END ELEVATION

NOTES

STIRRUPS IN CAP MAY BE SHIFTED AS NECESSARY TO CLEAR ANCHOR BOLTS.
 HOOKS ON V1 BARS MAY BE TURNED AS NECESSARY FOR PLACING REINFORCING STEEL.

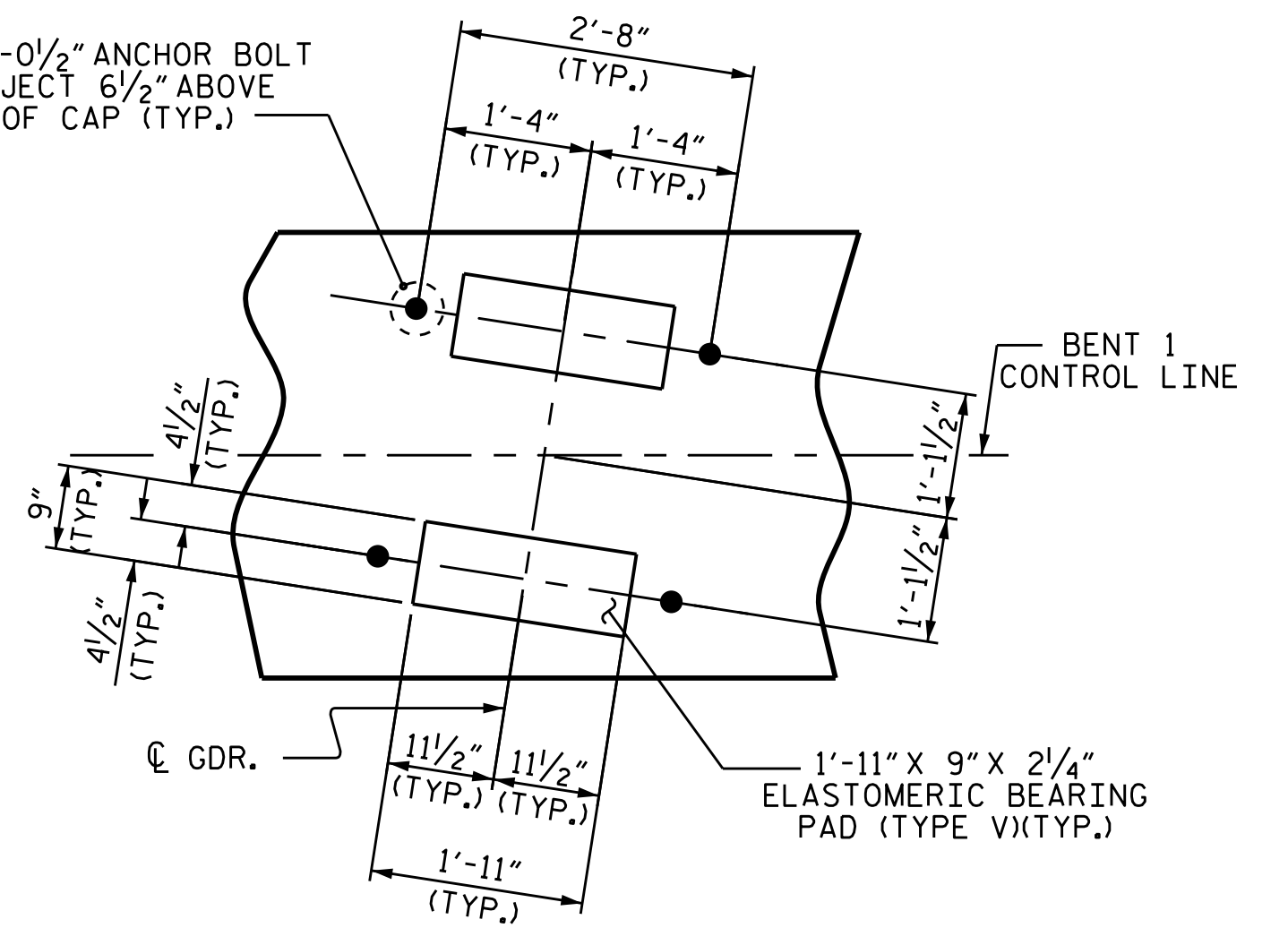

DETAIL "A"
TYP. EACH GDR.

PROJECT NO. U-2579C
 FORSYTH COUNTY
 STATION: 21+27.27 -Y2-

SHEET 1 OF 2



STATE OF NORTH CAROLINA
 DEPARTMENT OF TRANSPORTATION
 RALEIGH
 SUBSTRUCTURE
 BENT 1

DRAWN BY : J.K. BOWLES DATE : 5/16/16
 CHECKED BY : K.D. LAYNE DATE : 7/22/16
 DESIGN ENGINEER OF RECORD : J.K. BOWLES DATE : 7/22/16

REINFORCING STEEL, DIMENSIONS, AND DETAILS ARE TYPICAL FOR EACH COLUMN AND FOOTING.

DOCUMENT NOT CONSIDERED FINAL UNLESS ALL SIGNATURES COMPLETED

REVISIONS						SHEET NO.
NO.	BY:	DATE:	NO.	BY:	DATE:	S2-24
1			3			TOTAL SHEETS 30
2			4			

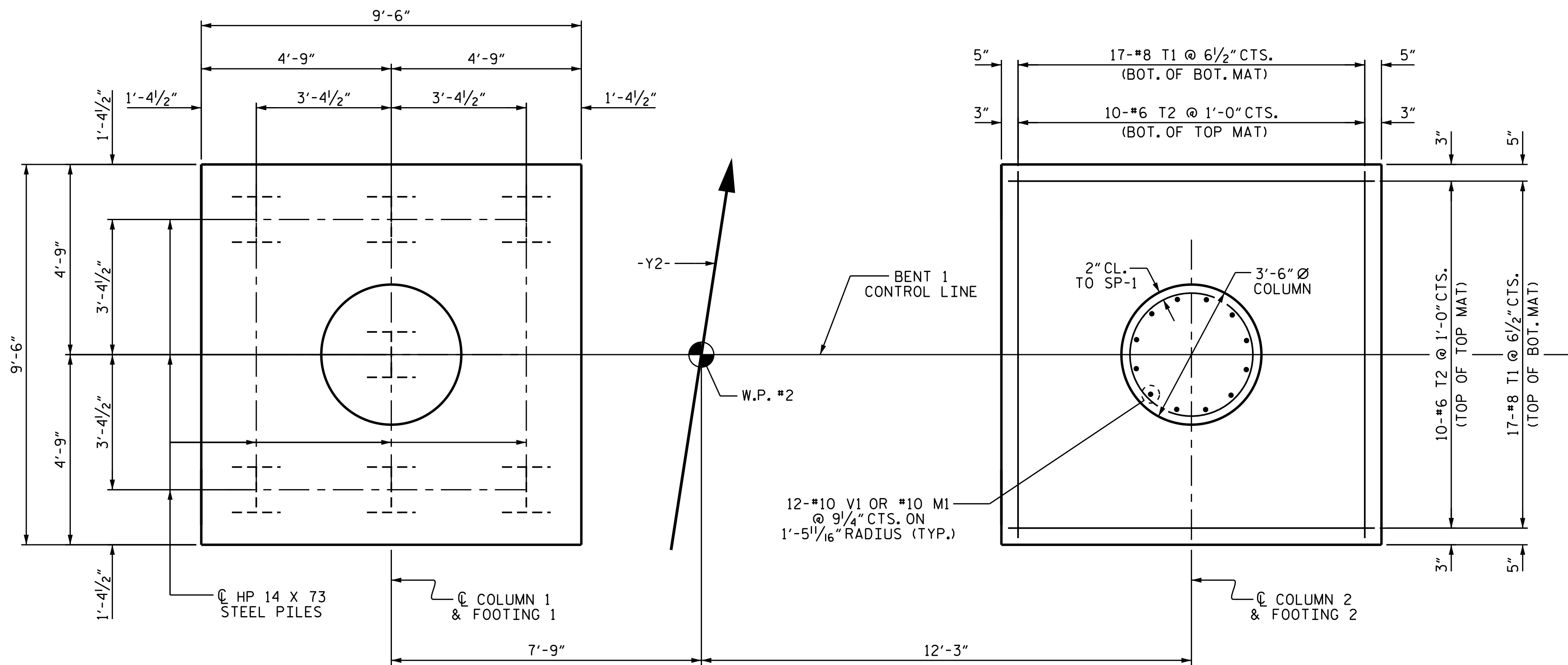

PLAN OF FOOTINGS & COLUMNS

PILES, REINFORCING STEEL, DIMENSIONS ARE TYPICAL FOR EACH COLUMN AND FOOTING.

BAR TYPES				BILL OF MATERIAL							
BAR NO.	SIZE	TYPE	LENGTH	WEIGHT	BAR NO.	SIZE	TYPE	LENGTH	WEIGHT		
B1	#10	1	35'-0"	1355	M1	#10	2	10'-1"	1041		
B2	#5	STR	32'-4"	202	S1	#5	3	12'-4"	347		
B3	#10	STR	32'-4"	974	S2	#5	3	11'-4"	378		
T1	#8	1	10'-10"	1967	T1	#8	1	10'-10"	1967		
T2	#6	STR	9'-0"	541	T2	#6	STR	9'-0"	541		
U1	#4	4	6'-8"	125	U1	#4	4	6'-8"	125		
U2	#4	4	6'-9"	27	U2	#4	4	6'-9"	27		
U3	#4	4	6'-6"	35	U3	#4	4	6'-6"	35		
V1	#10	2	21'-5"	2212	V1	#10	2	21'-5"	2212		
REINFORCING STEEL								LBS.	9,204		
SP-1								2	* 5	757'-4"	1012
SPIRAL COLUMN REINFORCING STEEL								LBS.	1,012		
* THE SP-1 SPIRAL REINFORCING STEEL SHALL BE W20 OR D-20 COLD DRAWN WIRE OR #4 PLAIN OR DEFORMED BAR.											
FOUNDATION EXCAVATION								LUMP SUM			
CLASS A CONCRETE POUR #1 (FOOTINGS)								C.Y.	25.1		
CLASS A CONCRETE POUR #2 (COLUMNS)								C.Y.	12.9		
CLASS A CONCRETE POUR #3 (CAP)								C.Y.	21.0		
TOTAL CLASS A CONCRETE								C.Y.	59.0		
HP 14 X 73 STEEL PILES No.: 14								LIN. FT.	350		
PILE DRIVING EQUIPMENT SETUP FOR HP 14 X 73 STEEL PILES								EA.	14		
STEEL PILE POINTS								EA.	14		

ALL BAR DIMENSIONS ARE OUT TO OUT.

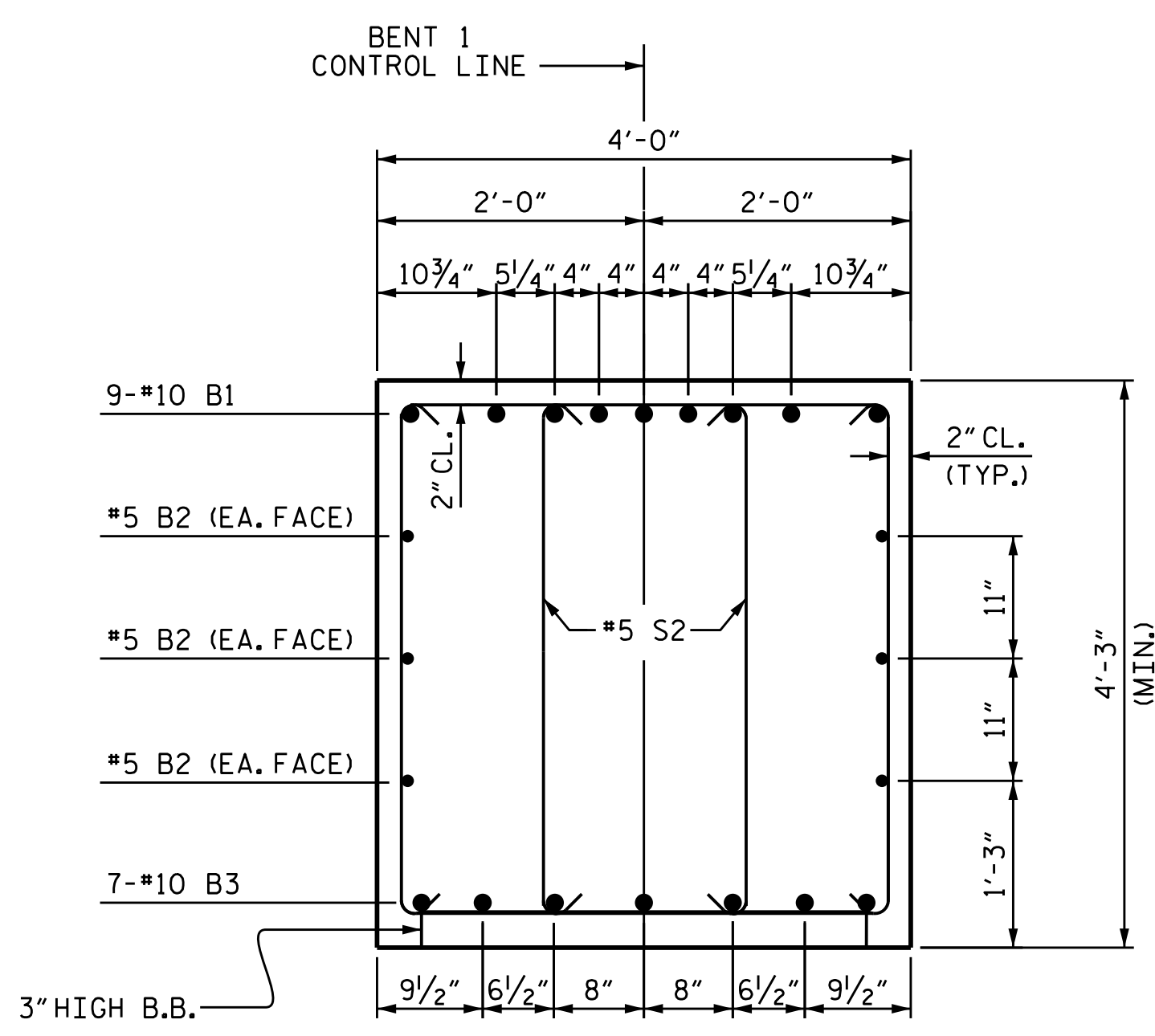

SECTION A-A

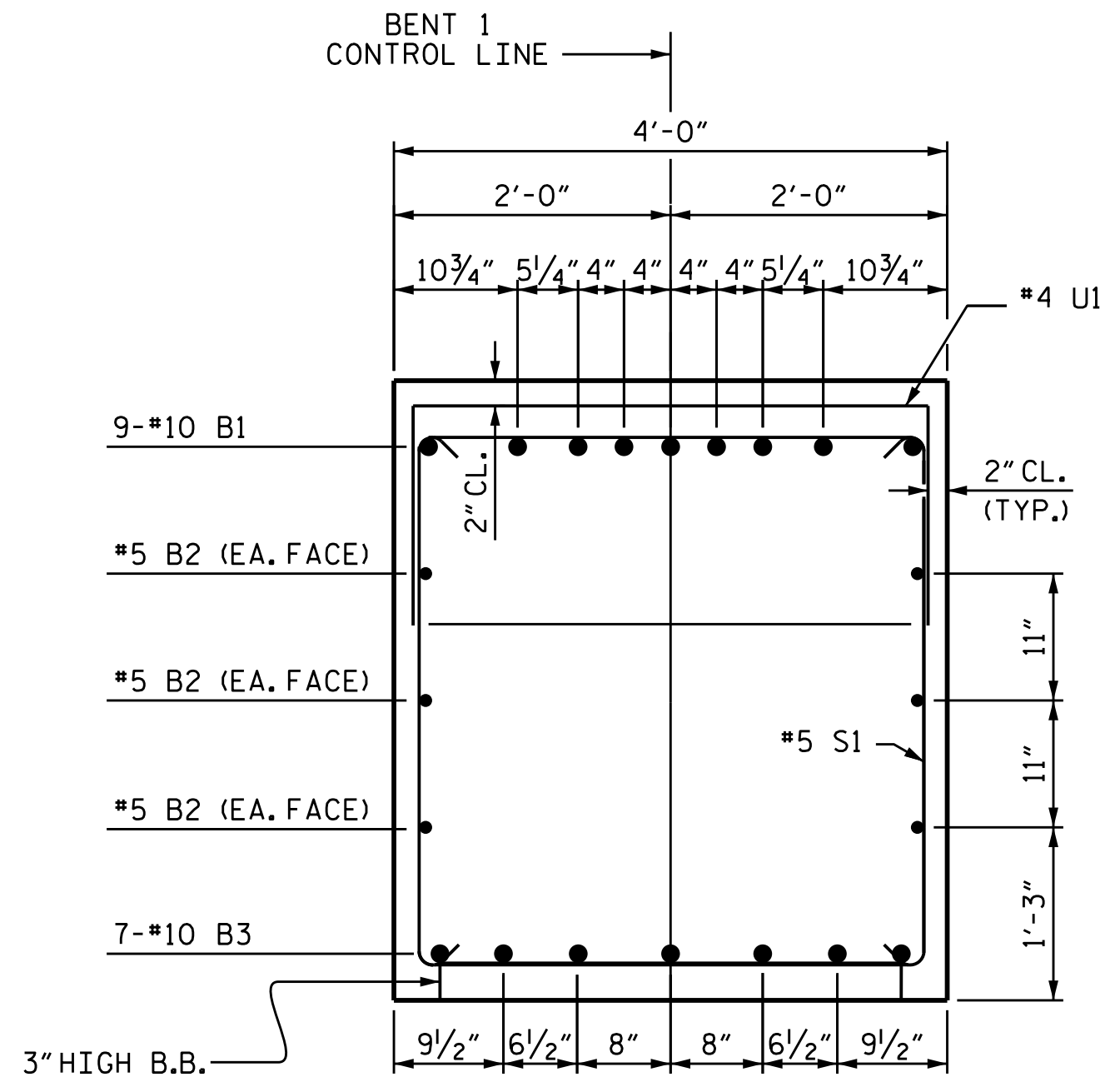

SECTION B-B

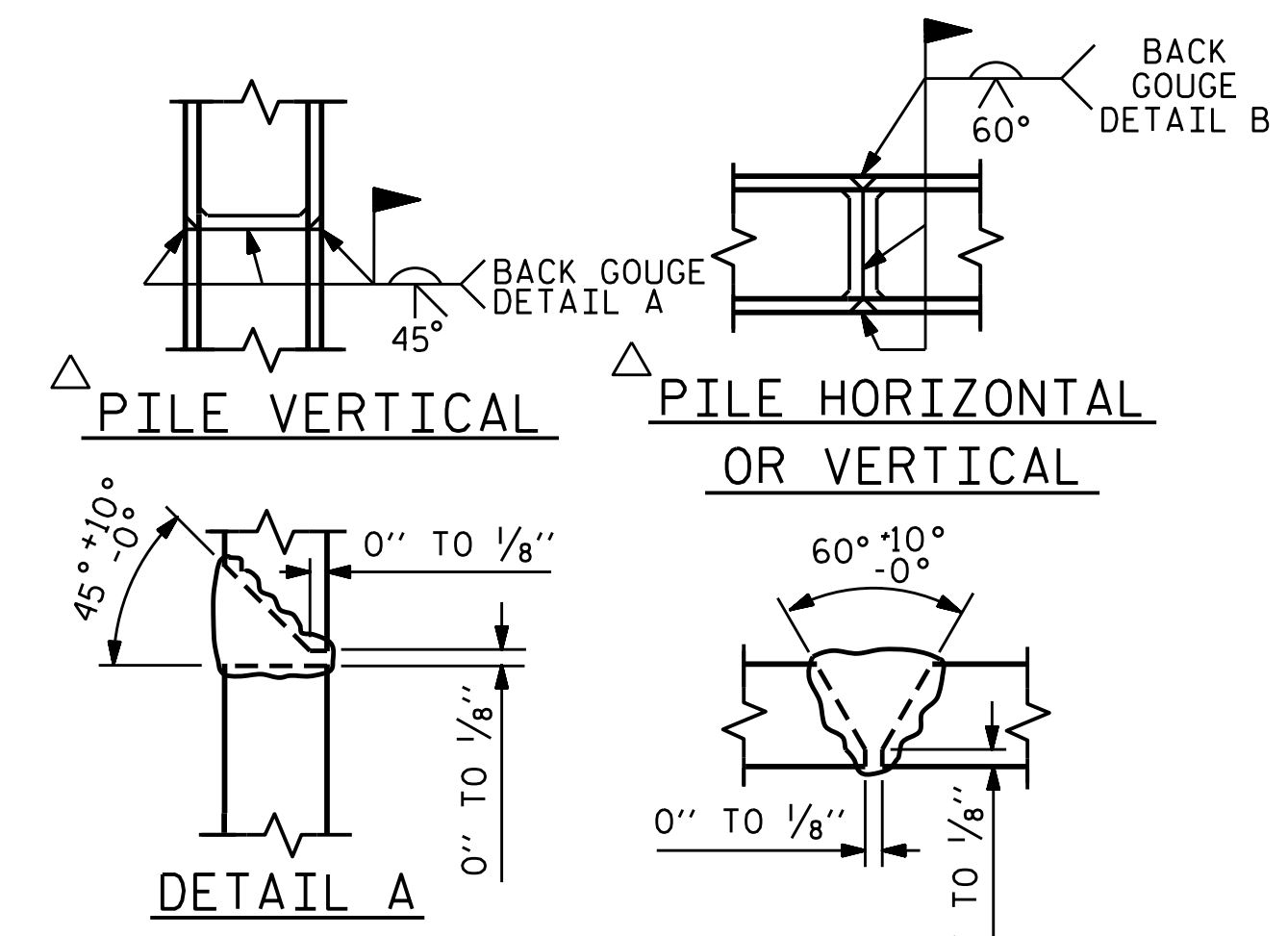

PILE SPLICE DETAILS

POSITION OF PILE DURING WELDING.

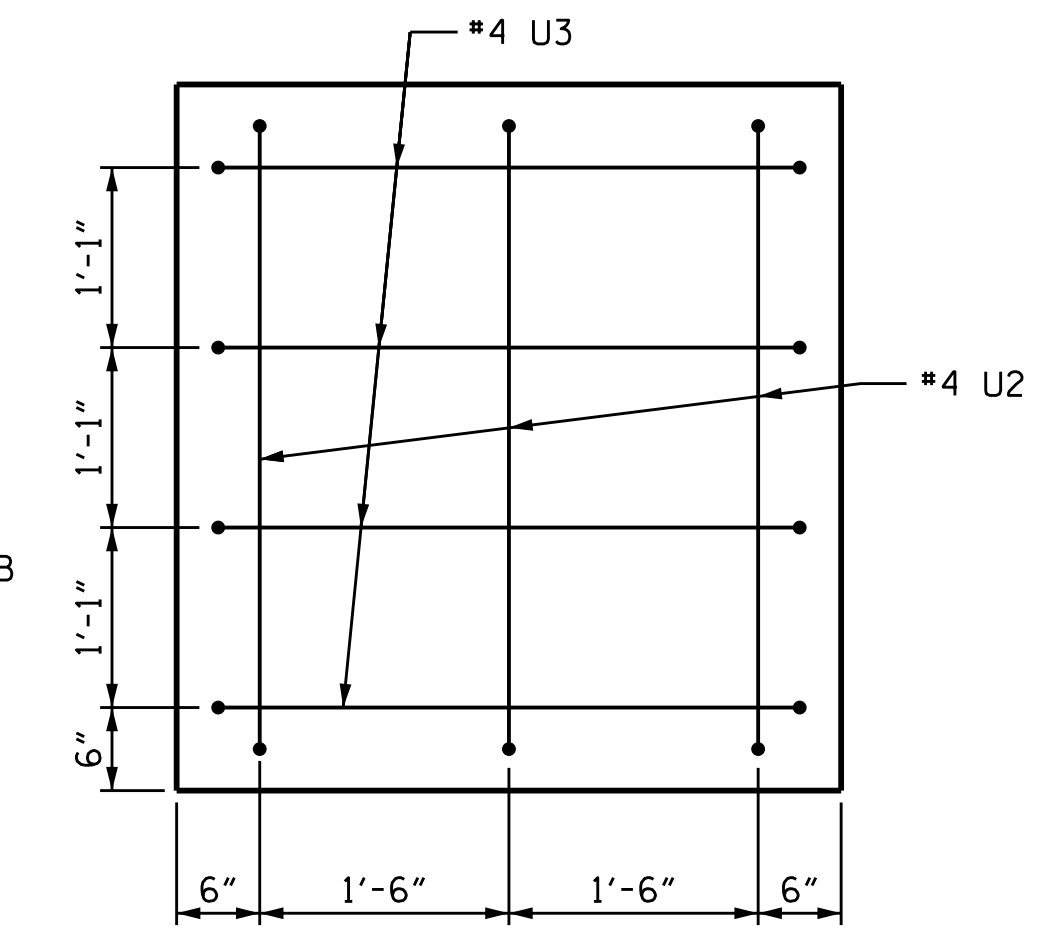

END VIEW

PROJECT NO. U-2579C
 FORSYTH COUNTY
 STATION: 21+27.27 -Y2-

SHEET 2 OF 2

STATE OF NORTH CAROLINA
 DEPARTMENT OF TRANSPORTATION
 RALEIGH
 SUBSTRUCTURE
 BENT 1

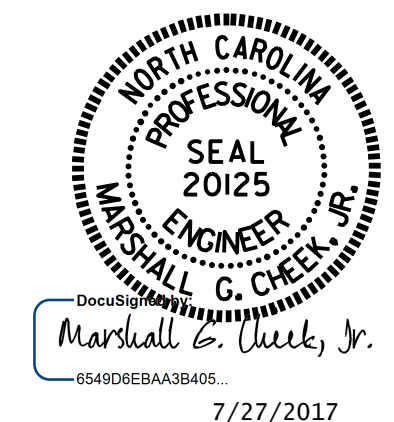

DRAWN BY : J. K. BOWLES DATE : 5/17/16
 CHECKED BY : K. D. LAYNE DATE : 7/22/16
 DESIGN ENGINEER OF RECORD : J. K. BOWLES DATE : 7/22/16

DOCUMENT NOT CONSIDERED FINAL UNLESS ALL SIGNATURES COMPLETED

REVISIONS				SHEET NO.	
NO.	BY:	DATE:	NO.	BY:	DATE:
1			3		
2			4		

TOTAL SHEETS 30

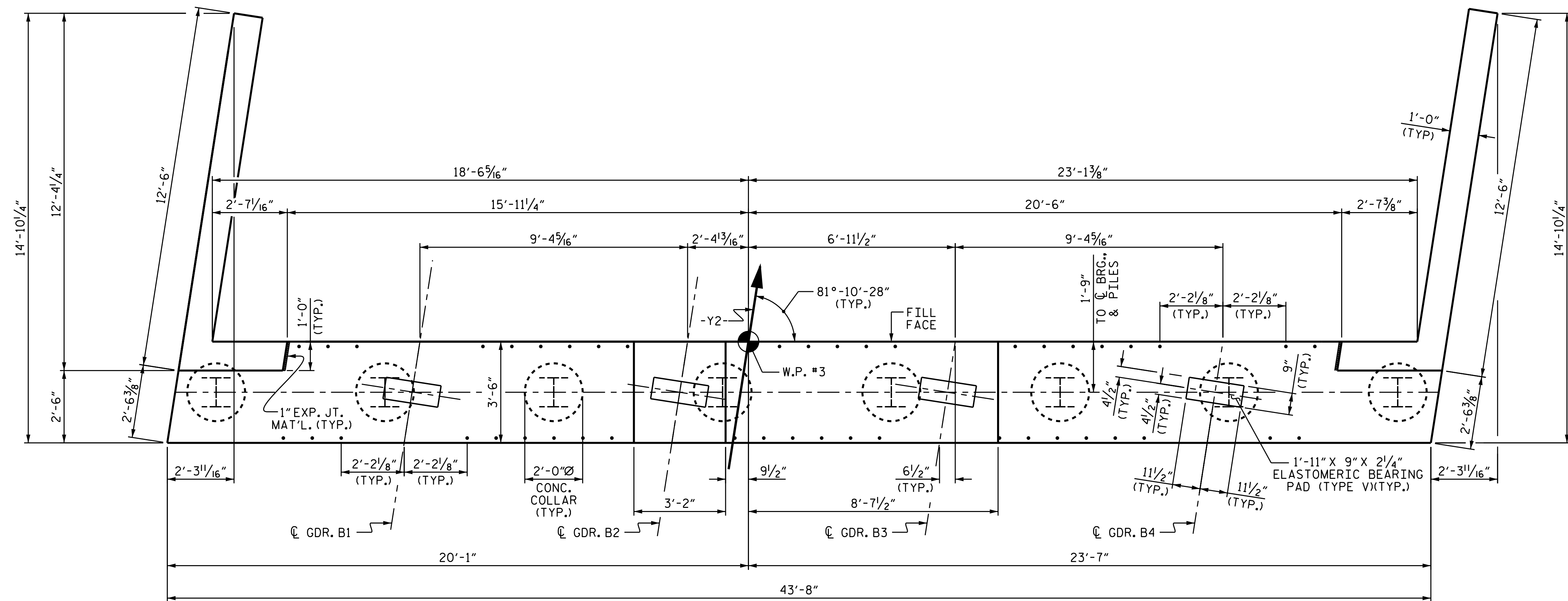

PLAN

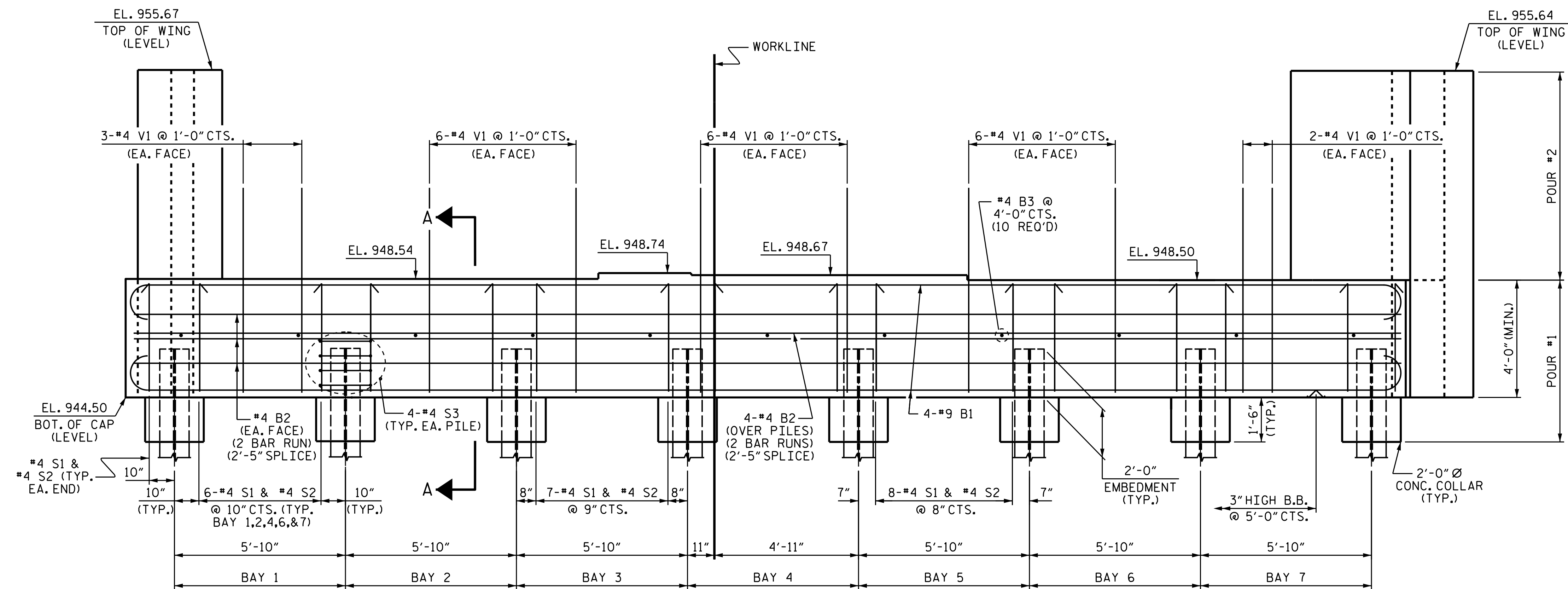

ELEVATION

NOTES

THE TOP SURFACE OF THE END BENT CAP, EXCEPT THE BEARING AREA, SHALL BE RAKED TO A DEPTH OF 1/4".

PROJECT NO. U-2579C
 FORSYTH COUNTY
 STATION: 21+27.27 -Y2-

SHEET 1 OF 2

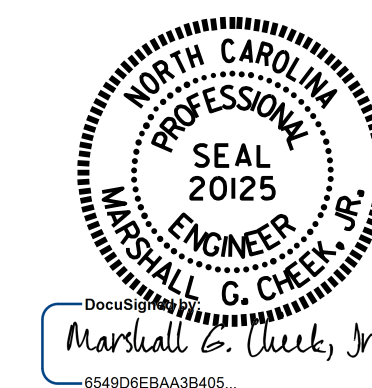

STATE OF NORTH CAROLINA
 DEPARTMENT OF TRANSPORTATION
 RALEIGH
 SUBSTRUCTURE
 INTEGRAL
 END BENT 2

DRAWN BY: J. K. BOWLES DATE: 5/10/16
 CHECKED BY: K. D. LAYNE DATE: 7/21/16
 DESIGN ENGINEER OF RECORD: J. K. BOWLES DATE: 7/21/16

DOCUMENT NOT CONSIDERED
 FINAL UNLESS ALL
 SIGNATURES COMPLETED

REVISIONS						SHEET NO.
NO.	BY:	DATE:	NO.	BY:	DATE:	S2-26
1			3			TOTAL SHEETS
2			4			30

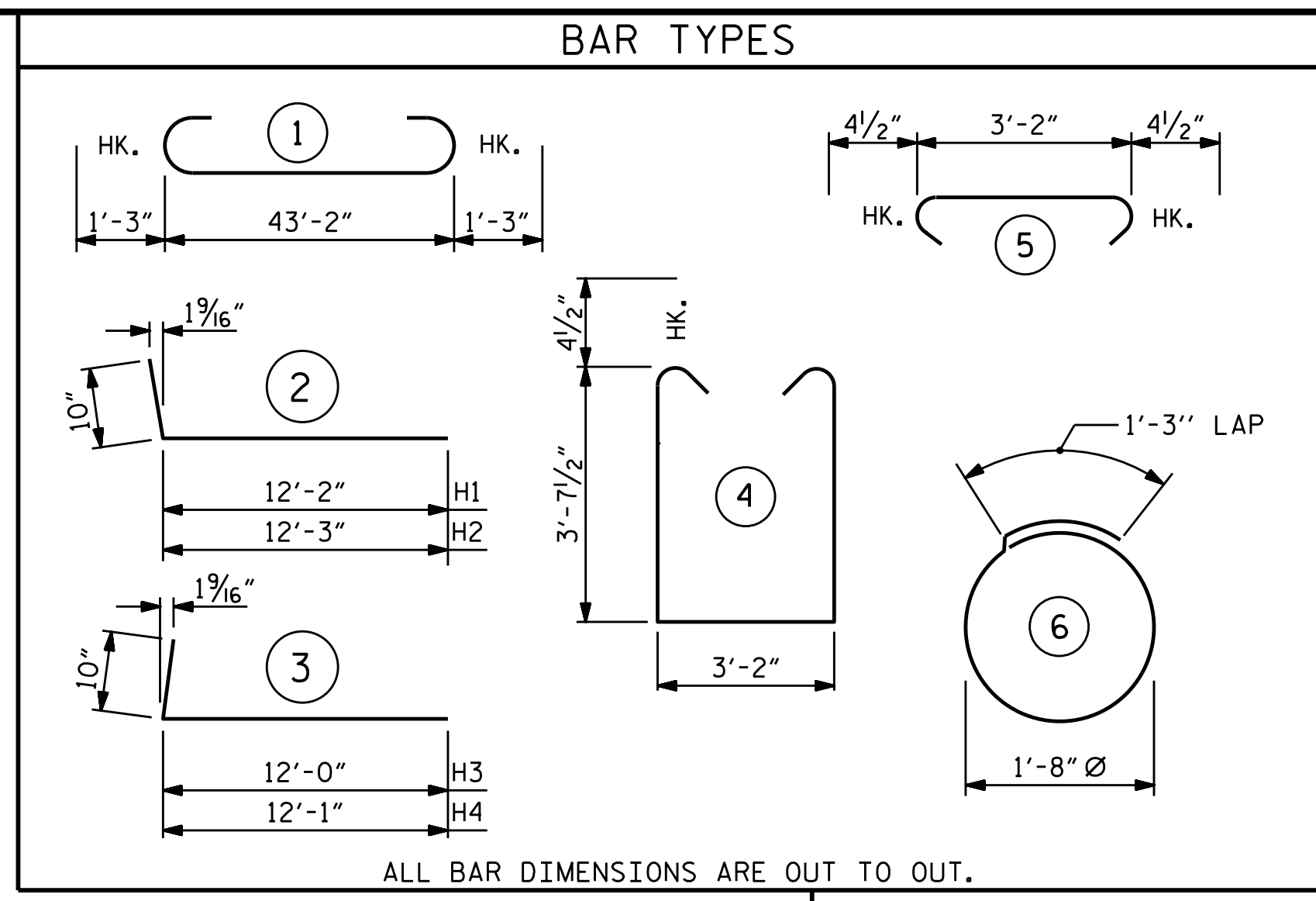
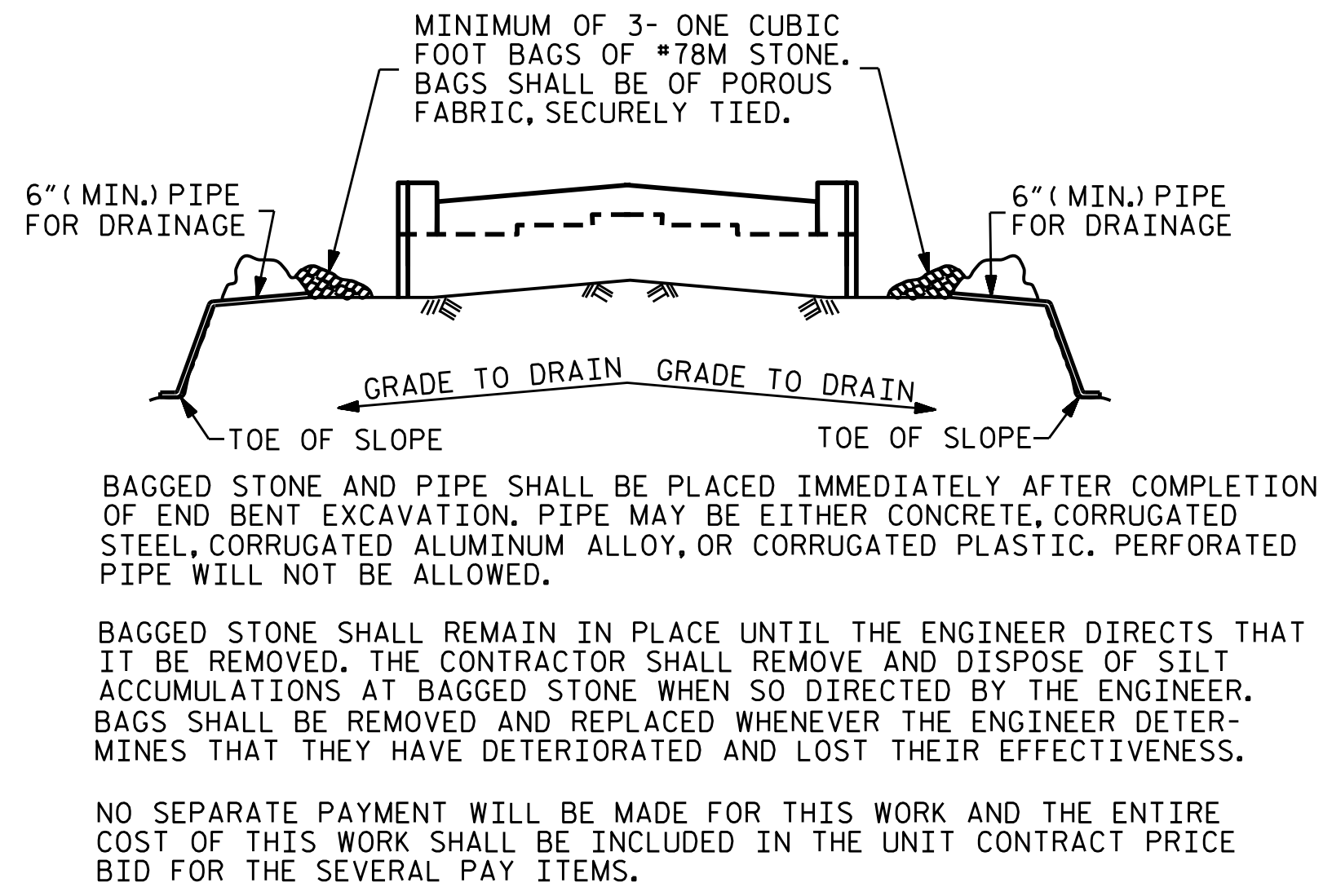
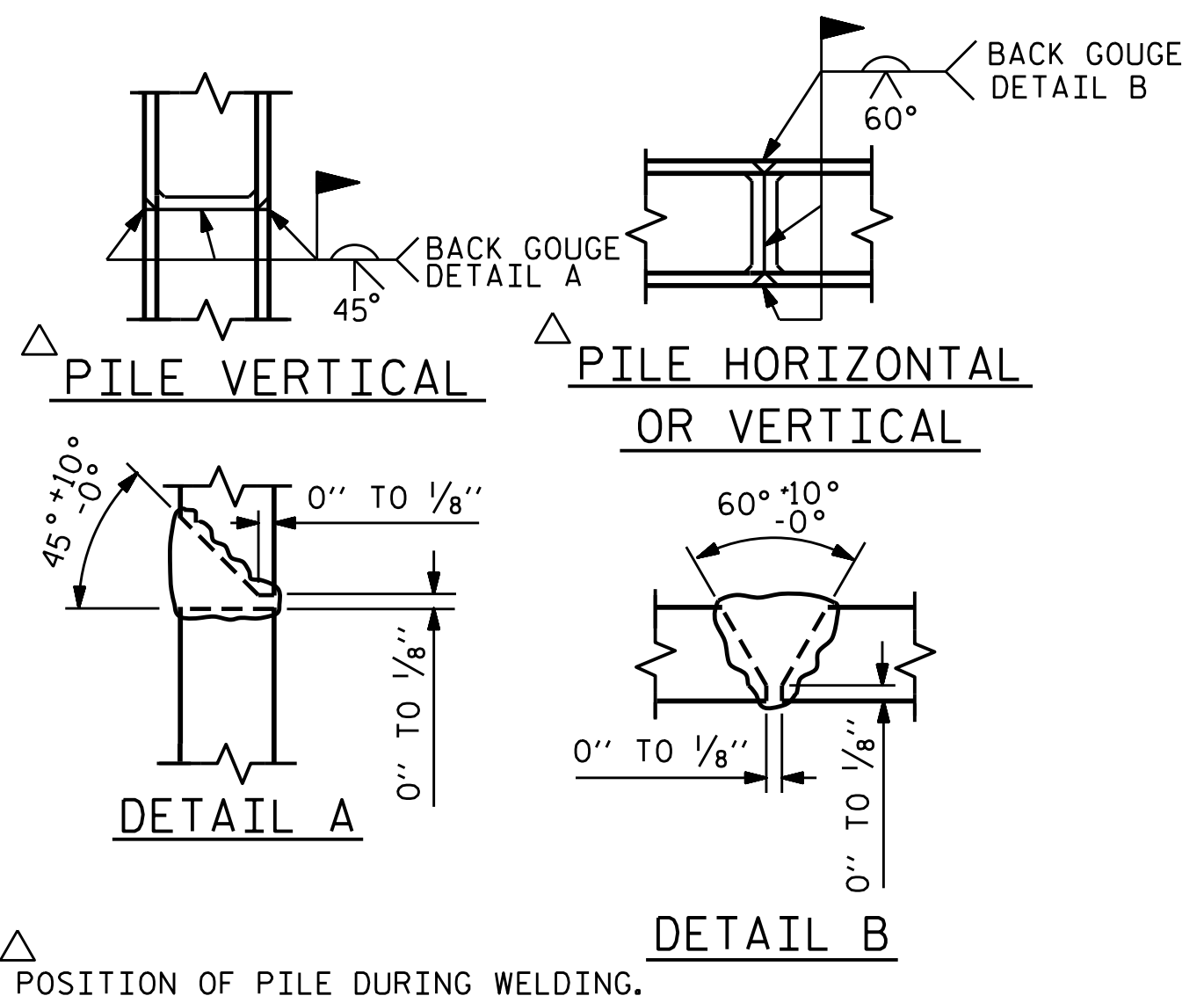

BILL OF MATERIAL					
END BENT 2					
BAR	NO.	SIZE	TYPE	LENGTH	WEIGHT
B1	8	#9	1	45'-8"	1242
B2	20	#4	STR	22'-11"	306
B3	10	#4	STR	3'-2"	21
H1	22	#5	2	13'-0"	298
H2	22	#5	2	13'-1"	300
H3	22	#5	3	12'-10"	294
H4	22	#5	3	12'-11"	296
K1	28	#4	STR	3'-3"	61
S1	47	#4	4	11'-2"	351
S2	47	#4	5	3'-11"	123
S3	32	#4	6	6'-6"	139
V1	46	#4	STR	6'-3"	192
V2	68	#5	STR	10'-9"	762
REINFORCING STEEL				LBS.	4,385
CLASS A CONCRETE					
POUR #1 CAP, LOWER PART OF WINGS, & COLLARS				C.Y.	27.8
POUR #2 UPPER PART OF WINGS				C.Y.	8.0
TOTAL				C.Y.	35.8
HP 12 X 53 STEEL PILES				NO.: 8	LIN. FT. 460

PILE SPLICE DETAILS

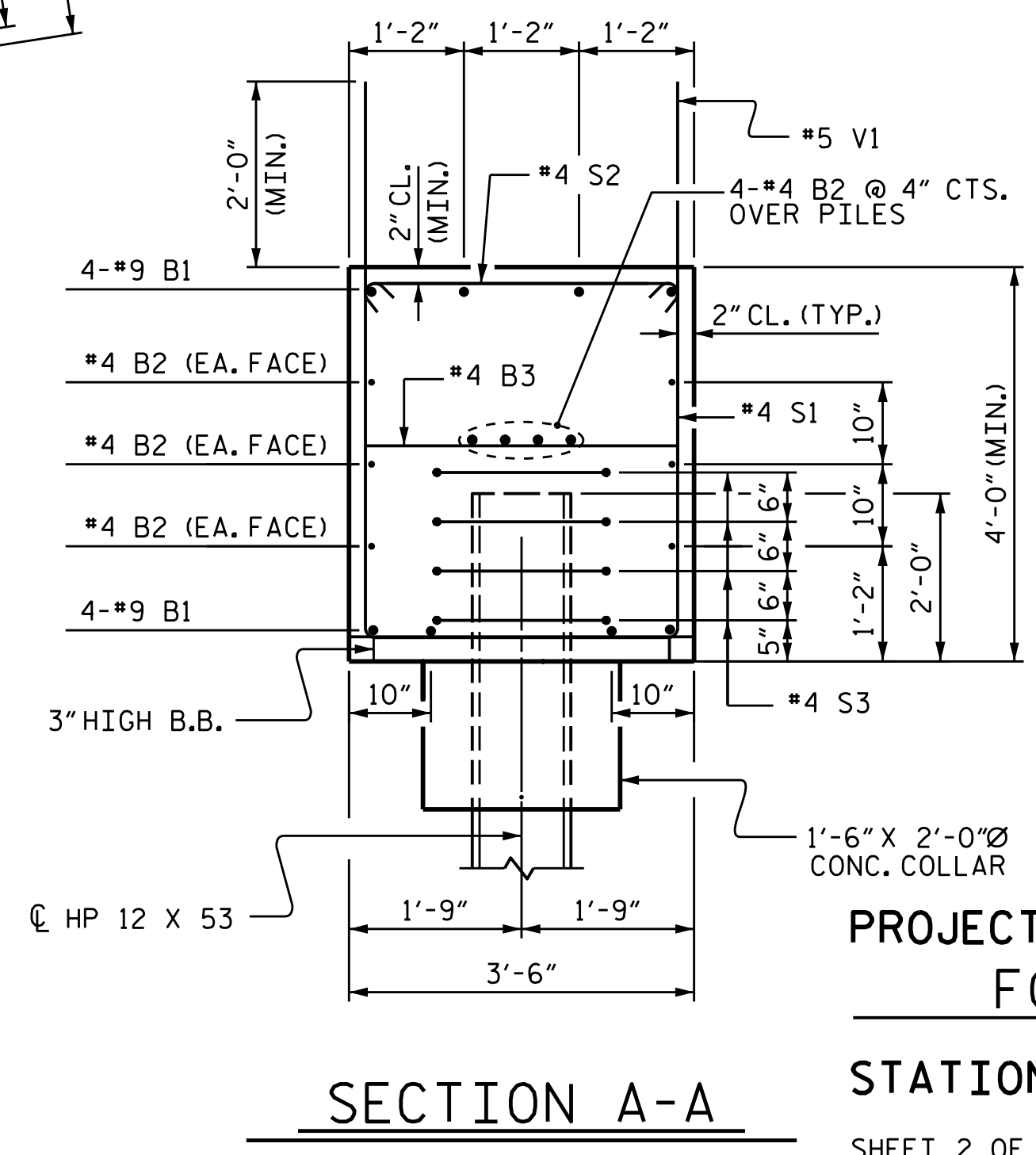
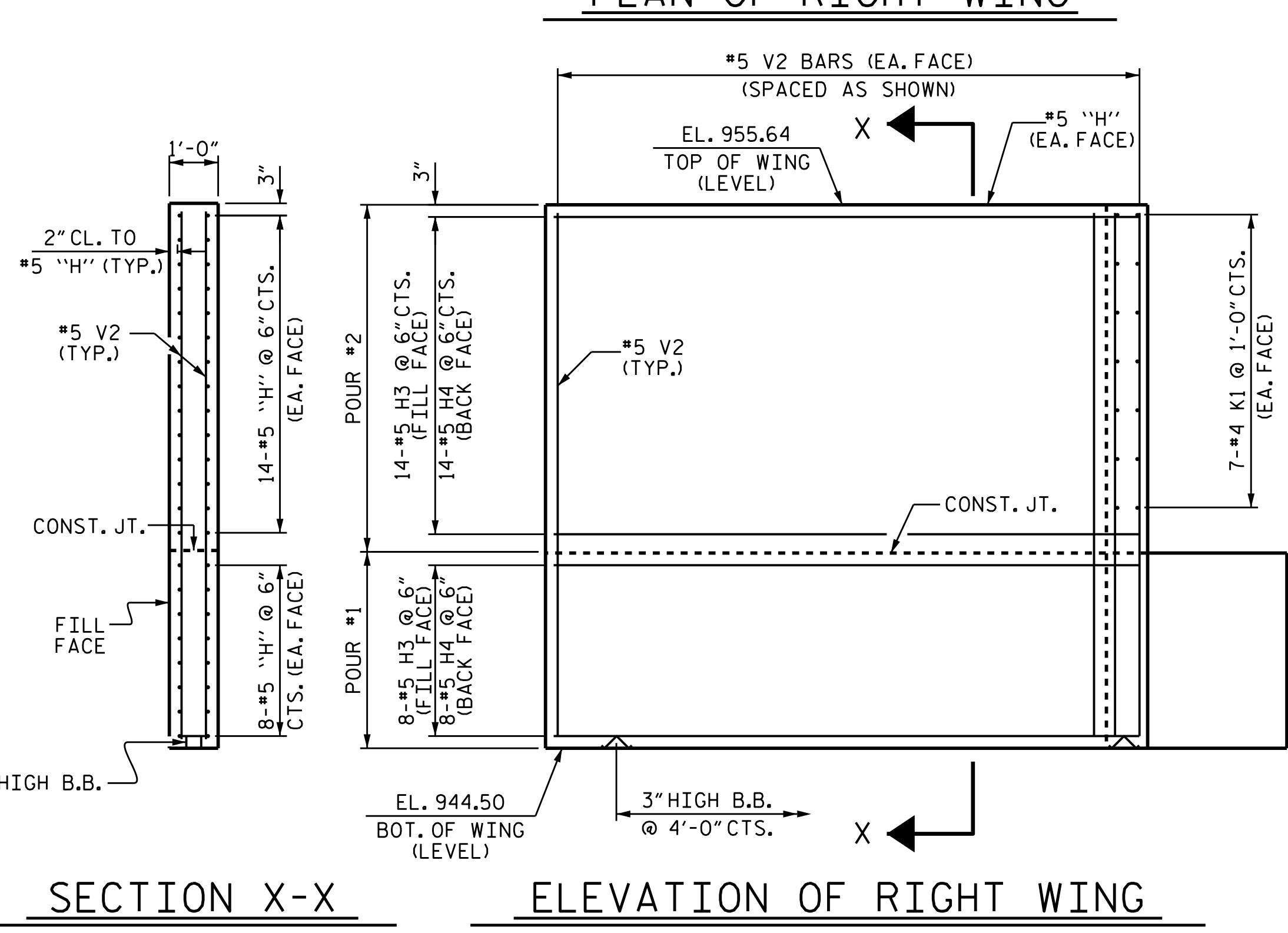
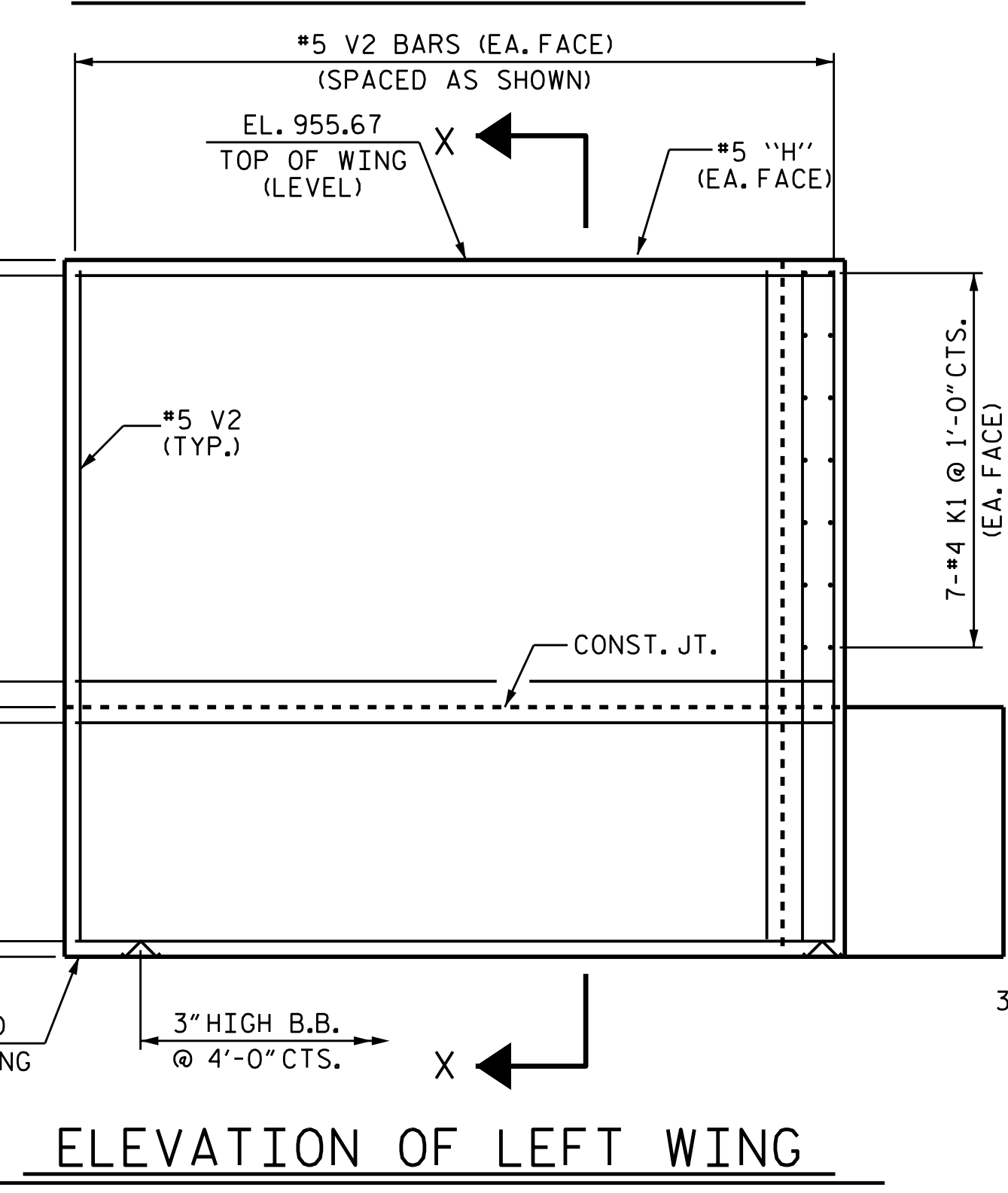
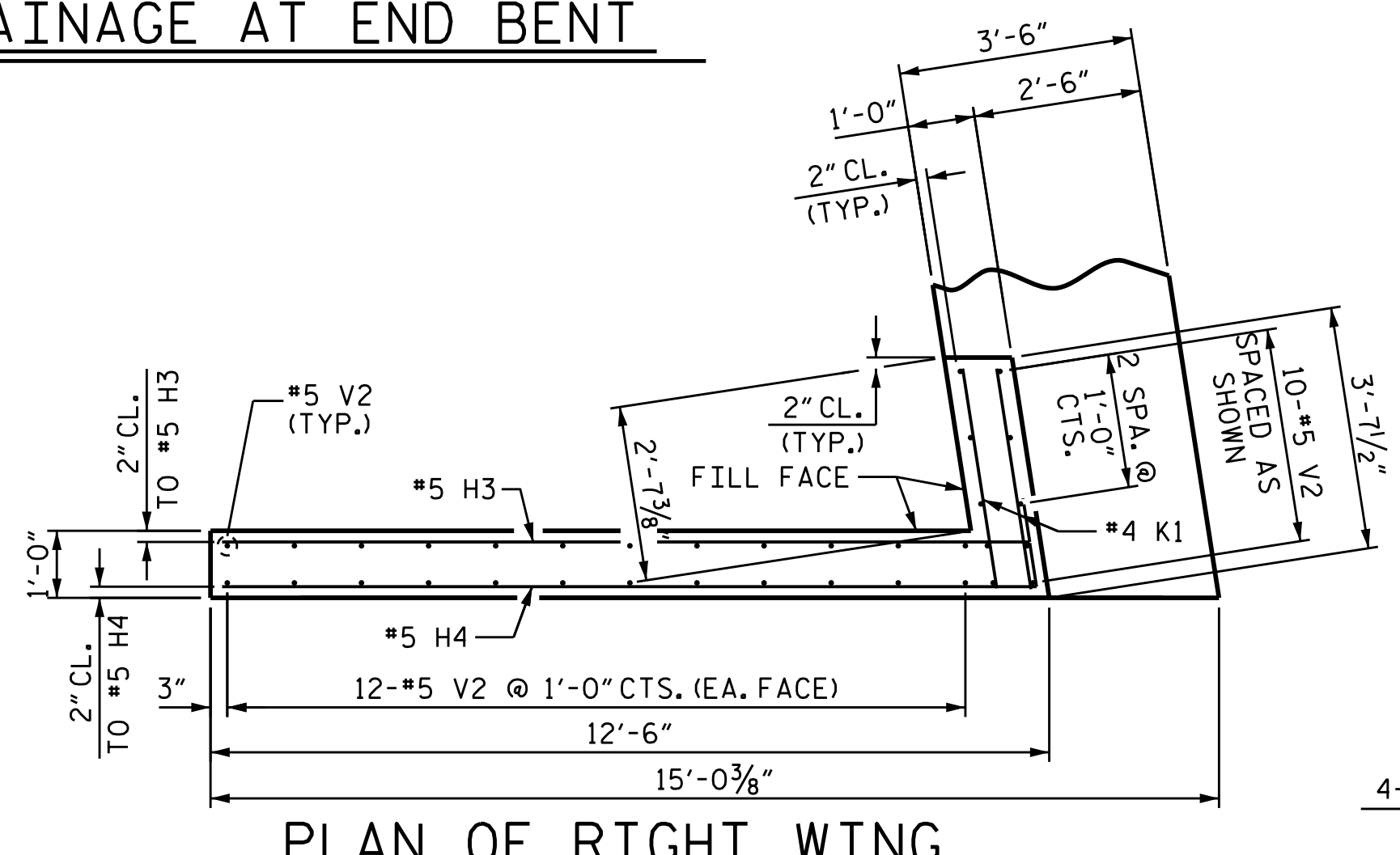
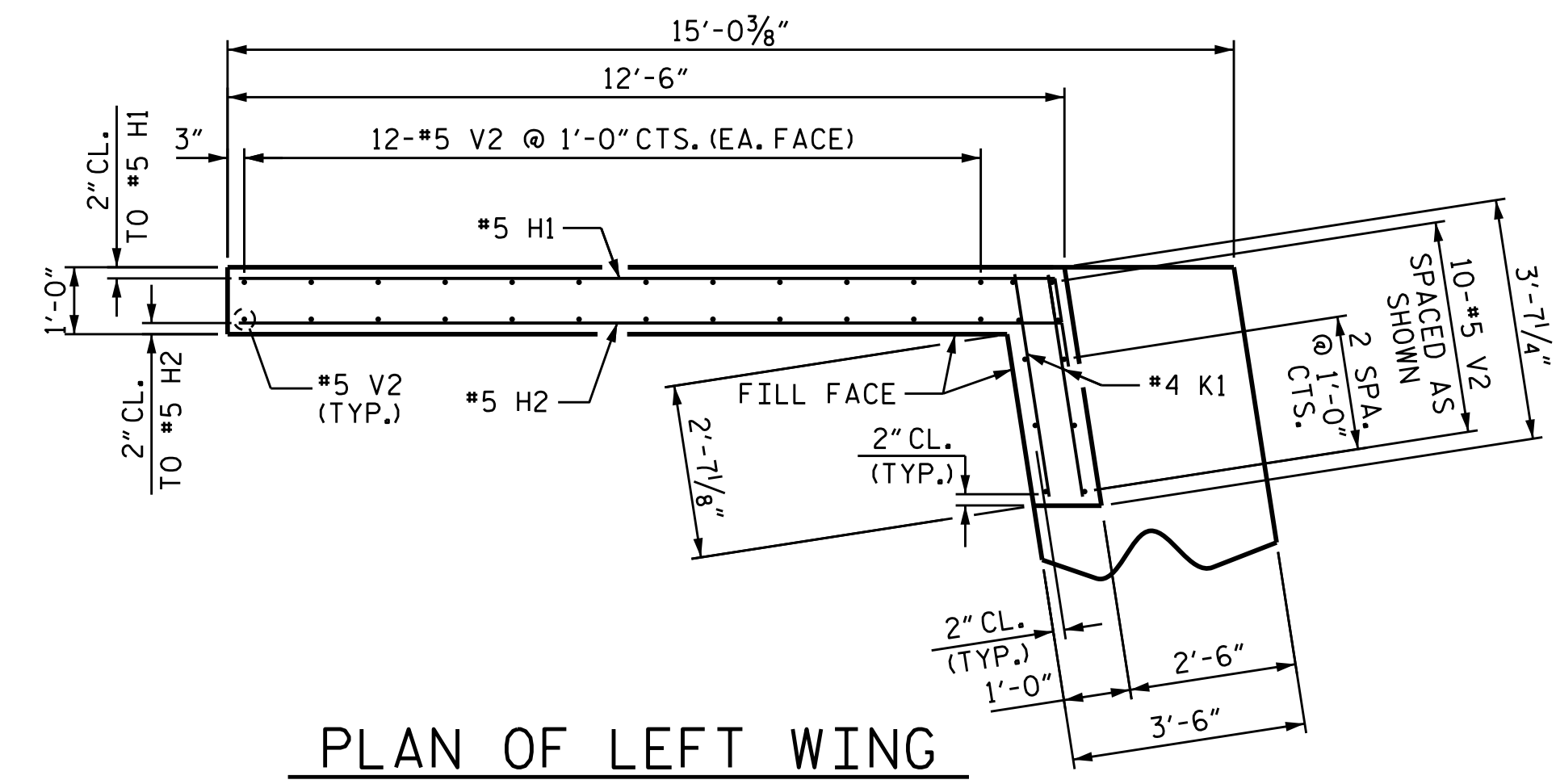

PROJECT NO. U-2579C
 FORSYTH COUNTY
 STATION: 21+27.27 -Y2-

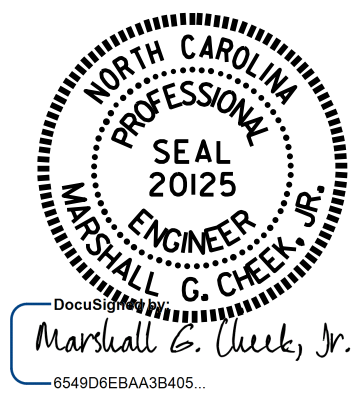

REVISIONS					
NO.	BY:	DATE:	NO.	BY:	DATE:
1			3		
2			4		

SHEET NO. **S2-27**
 TOTAL SHEETS **30**

DRAWN BY: J. K. BOWLES DATE: 5/10/16
 CHECKED BY: K. D. LAYNE DATE: 7/21/2016
 DESIGN ENGINEER OF RECORD: J. K. BOWLES DATE: 7/21/2016

DOCUMENT NOT CONSIDERED FINAL UNLESS ALL SIGNATURES COMPLETED

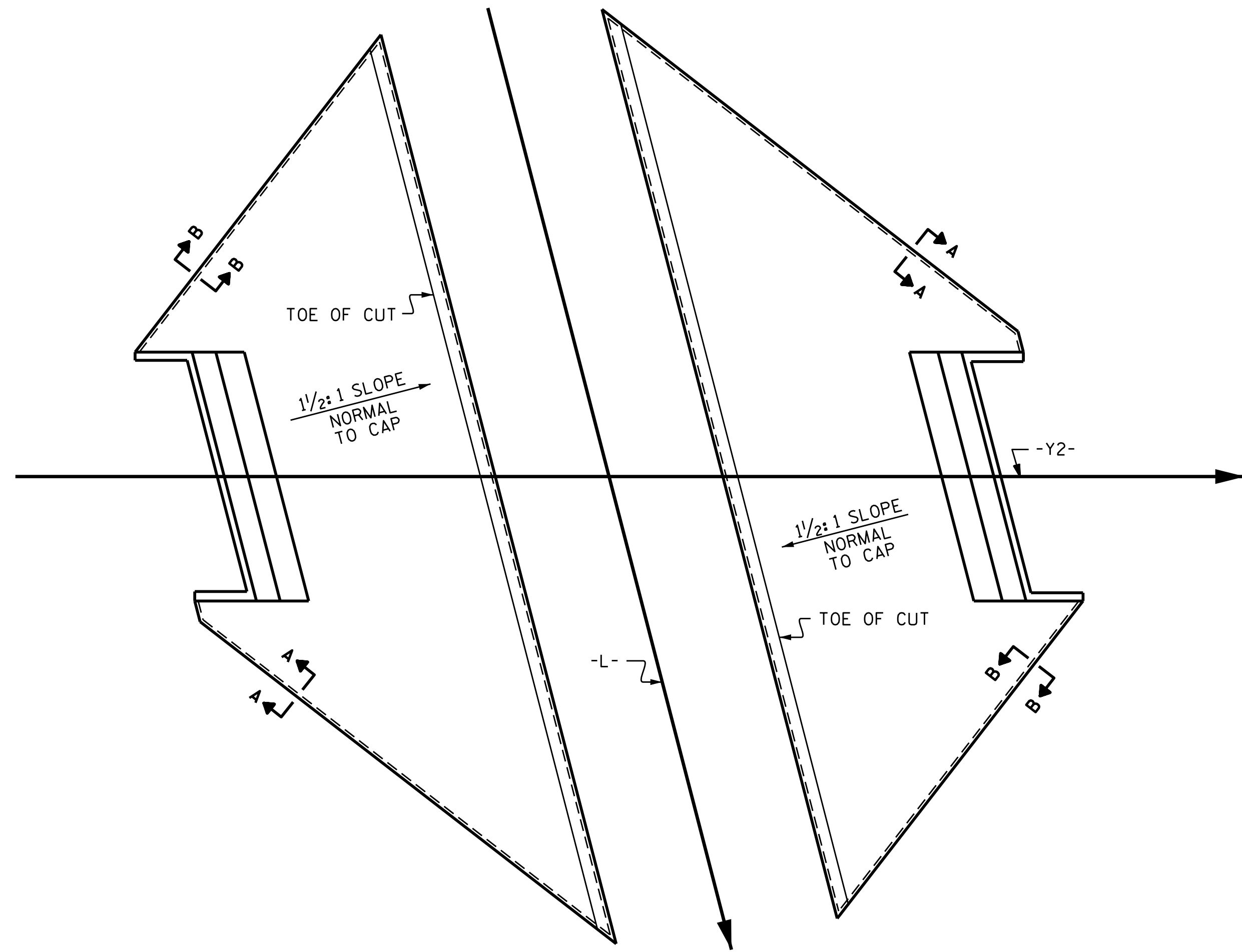

PLAN

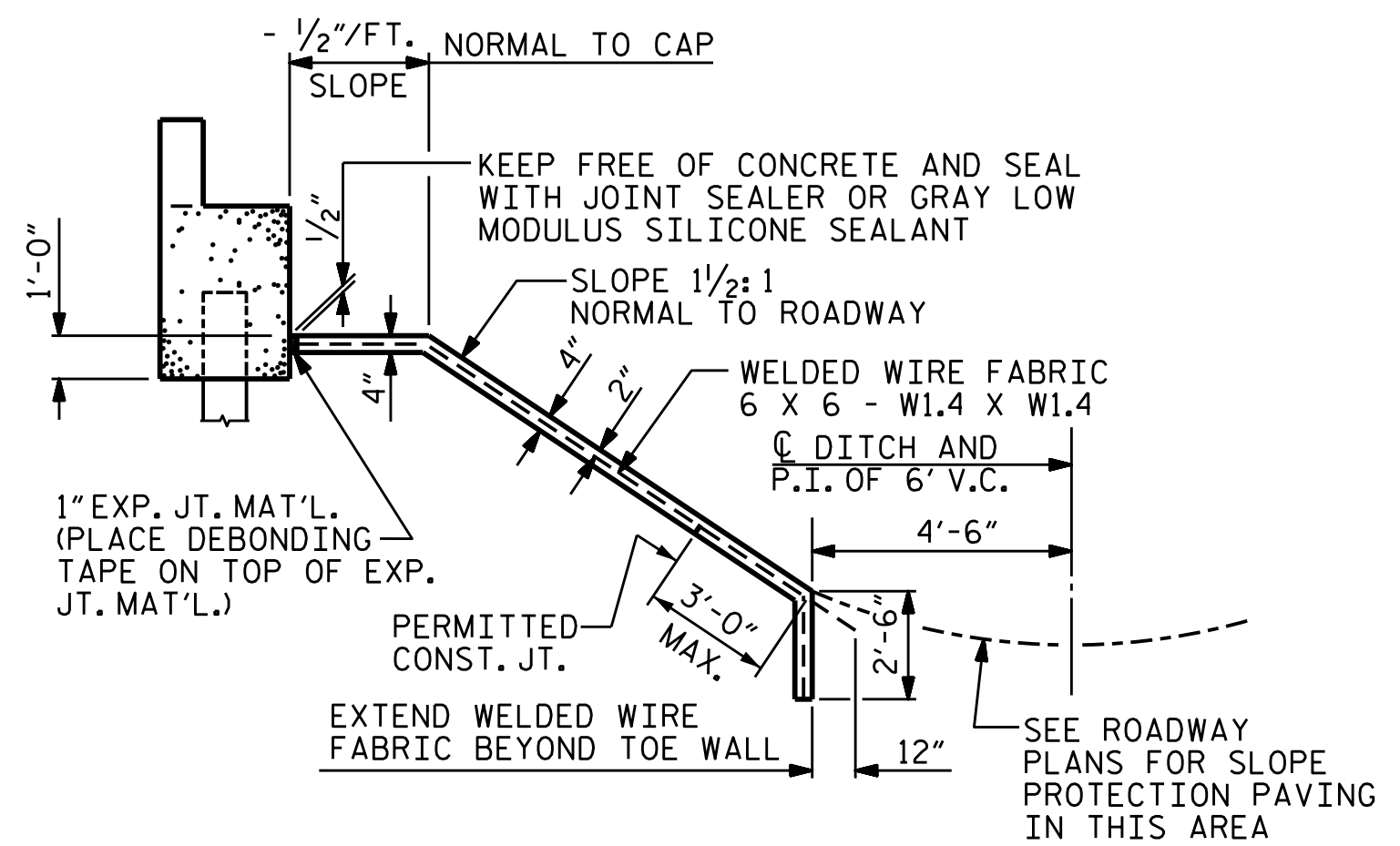

SECTION ALONG C SURVEY WHEN SLOPE CATCHES IN DITCH

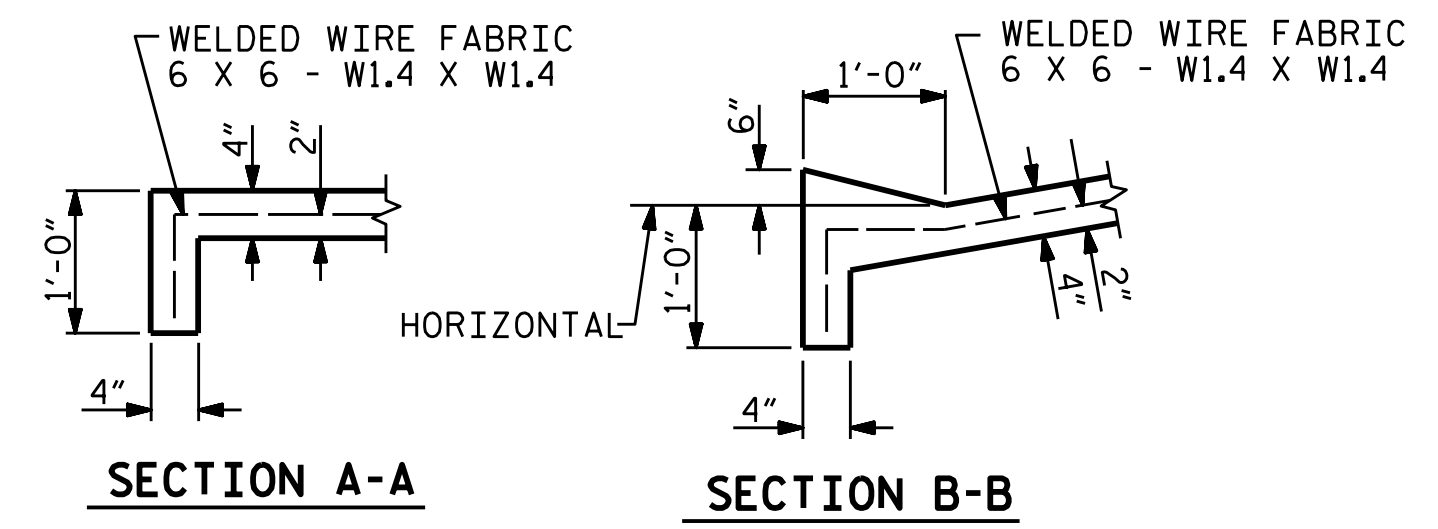

SECTION A-A

SECTION B-B

GENERAL NOTES

STRAIGHT EDGING WILL NOT BE REQUIRED UNLESS, IN THE OPINION OF THE ENGINEER, VISUAL INSPECTION INDICATES A NEED FOR IT. MEASUREMENT AND PAYMENT SHALL BE AS PRESCRIBED IN SECTION 462 OF THE STANDARD SPECIFICATIONS. FOR BERM WIDTH, SEE GENERAL DRAWING. SLOPE PROTECTION SHALL CONSIST OF 4" POURED-IN-PLACE CONCRETE PAVING AS SHOWN IN THE DETAILS ON THIS SHEET. CONCRETE SHALL BE CLASS "B". THE CONCRETE SURFACE SHALL BE FLOATED WITH A WOODEN FLOAT AND FINISHED. WELDED WIRE FABRIC REINFORCING SHALL BE 6 X 6 - W1.4 X W1.4, 60" WIDE. SLOPE PROTECTION SHALL BE POURED IN 5' STRIPS AS SHOWN IN THE "POURING DETAIL" WITH 2'-0" LONG #4 BARS PLACED ALONG THE SLOPE BETWEEN STRIPS AT 1'-6" MAXIMUM SPACING. SLOPE PROTECTION MAY BE POURED IN ALTERNATE 4' AND 5' STRIPS AS SHOWN IN THE "OPTIONAL POURING DETAIL" WITH ADJACENT RUNS OF WELDED WIRE FABRIC LAPPING AT LEAST 6". THE COST OF THE WELDED WIRE FABRIC AND #4 BARS, IF USED, SHALL BE INCLUDED IN THE CONTRACT UNIT PRICE BID PER SQUARE YARD FOR 4" SLOPE PROTECTION.

BRIDGE @ STA. 21+27.27 -Y2-	4 INCH SLOPE PROTECTION	* WELDED WIRE FABRIC 60 INCHES WIDE
	SQUARE YARDS	APPROX. L.F.
END BENT 1	295	531
END BENT 2	368	662
TOTAL	663	1193

* QUANTITY SHOWN IS BASED ON 5' POURS.

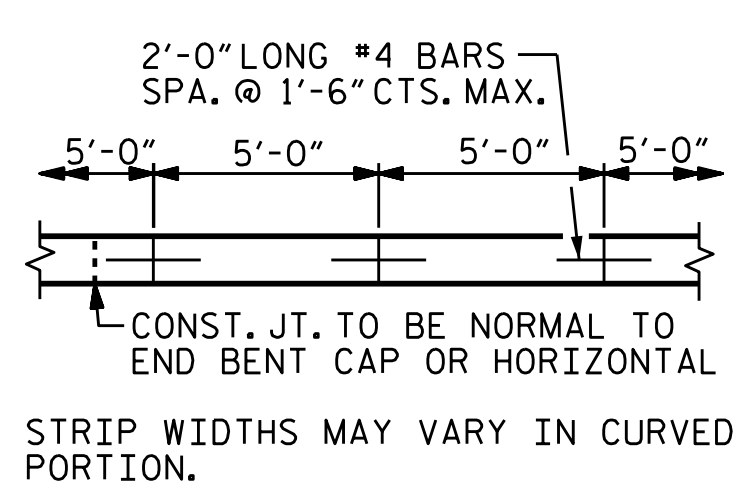

POURING DETAIL

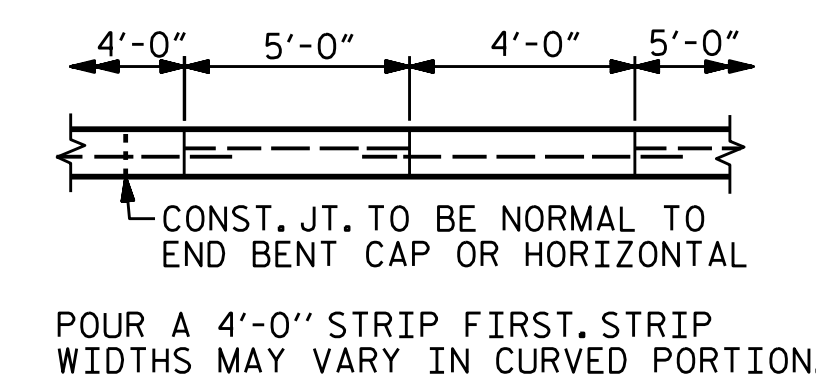

OPTIONAL POURING DETAIL

PROJECT NO. U-2579C
FORSYTH COUNTY
 STATION: 21+27.27 -Y2-

SHEET 1 OF 2



STATE OF NORTH CAROLINA
 DEPARTMENT OF TRANSPORTATION
 RALEIGH
 STANDARD
 SLOPE PROTECTION
 DETAILS

ASSEMBLED BY : H. T. BARBOUR	DATE : 1-23-17
CHECKED BY : T. L. AVERETTE	DATE : 2-21-17
DRAWN BY : ELR 5/92	REV. 10/1/11 MAA/GM
CHECKED BY : GRP 6/92	REV. 12/21/11 MAA/GM
	REV. 1/16 MAA/TMG

DOCUMENT NOT CONSIDERED
 FINAL UNLESS ALL
 SIGNATURES COMPLETED

REVISIONS						SHEET NO.
NO.	BY:	DATE:	NO.	BY:	DATE:	S2-28
1			3			TOTAL SHEETS 30
2			4			

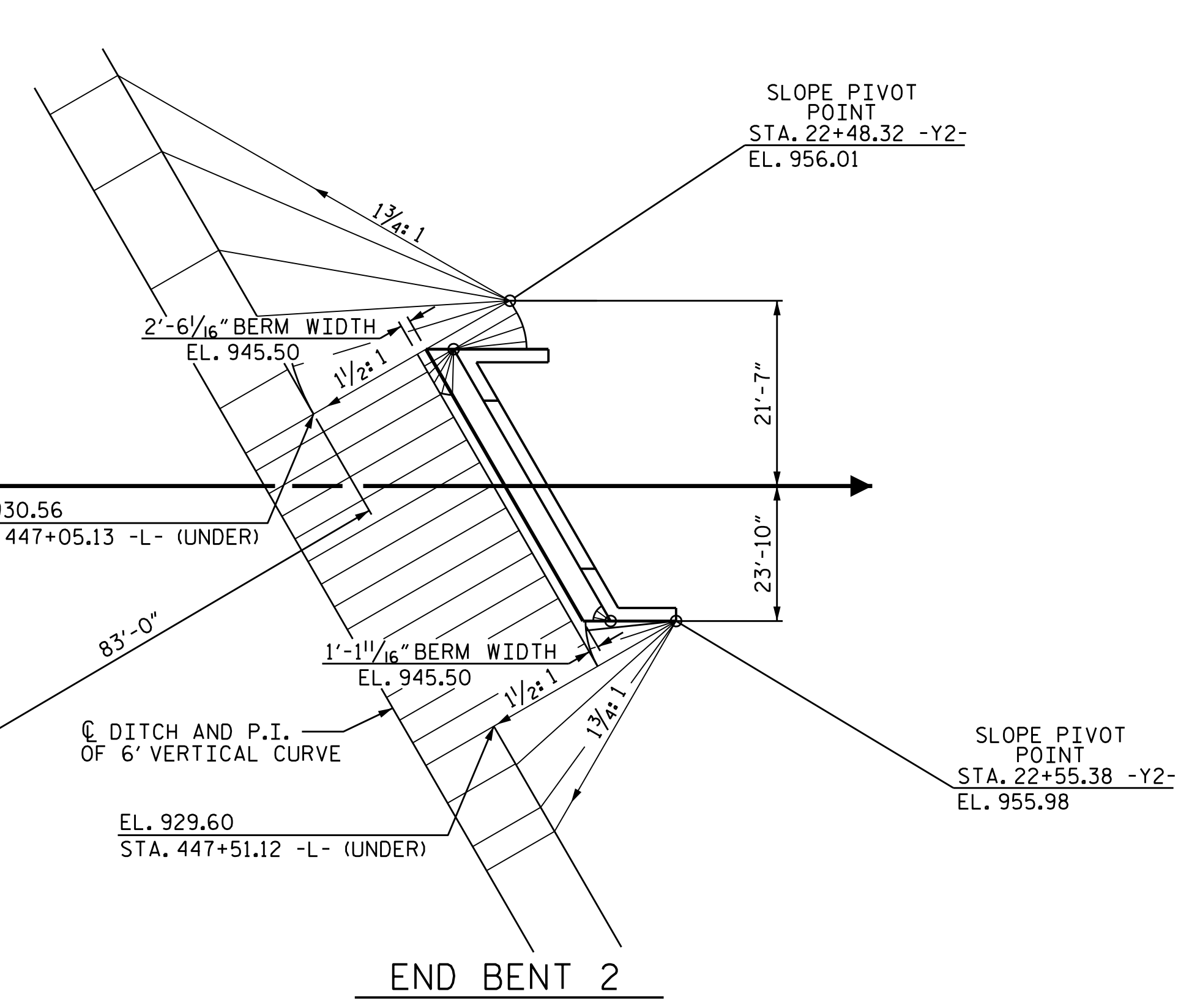
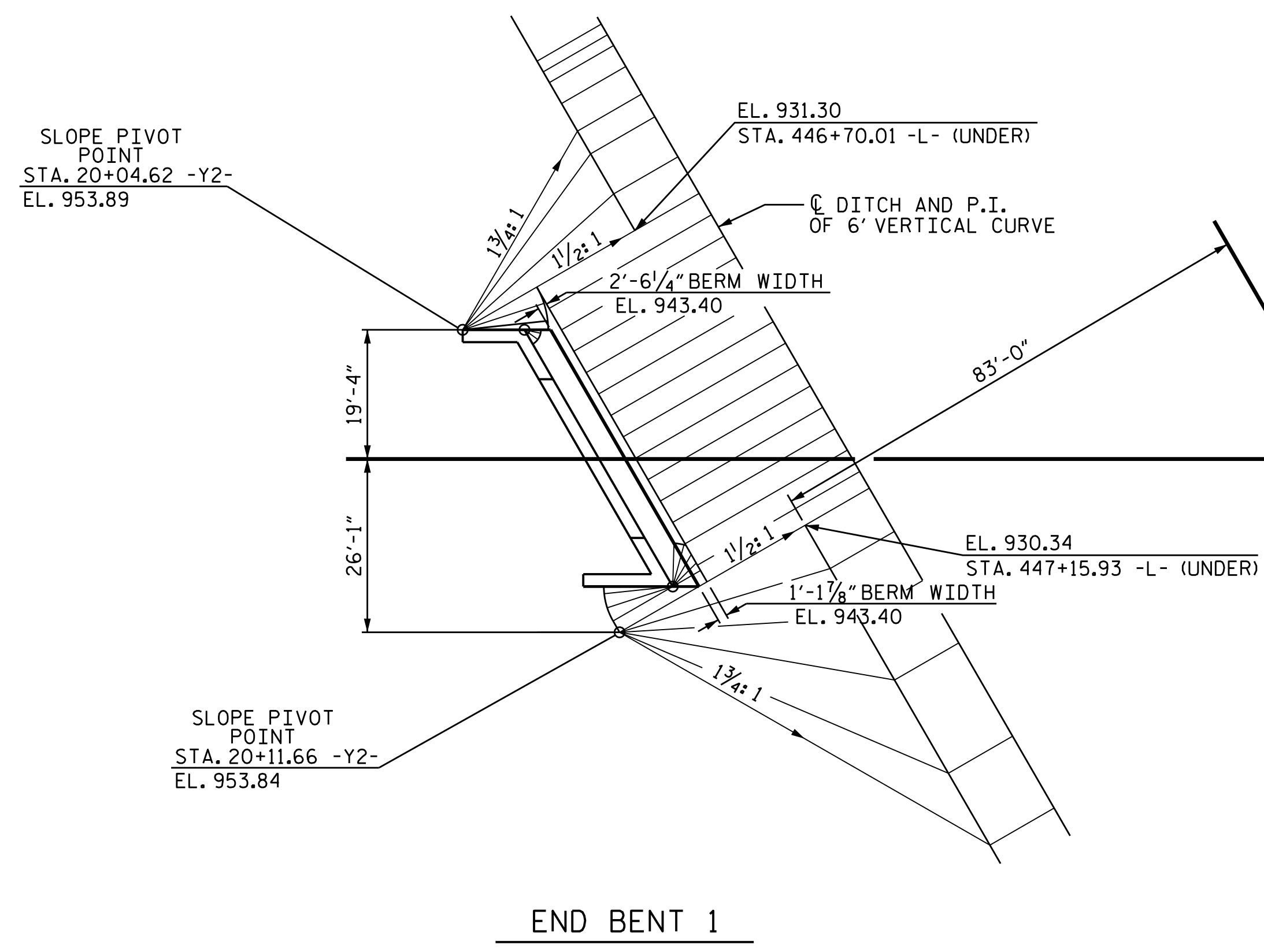

PLAN - GRADING

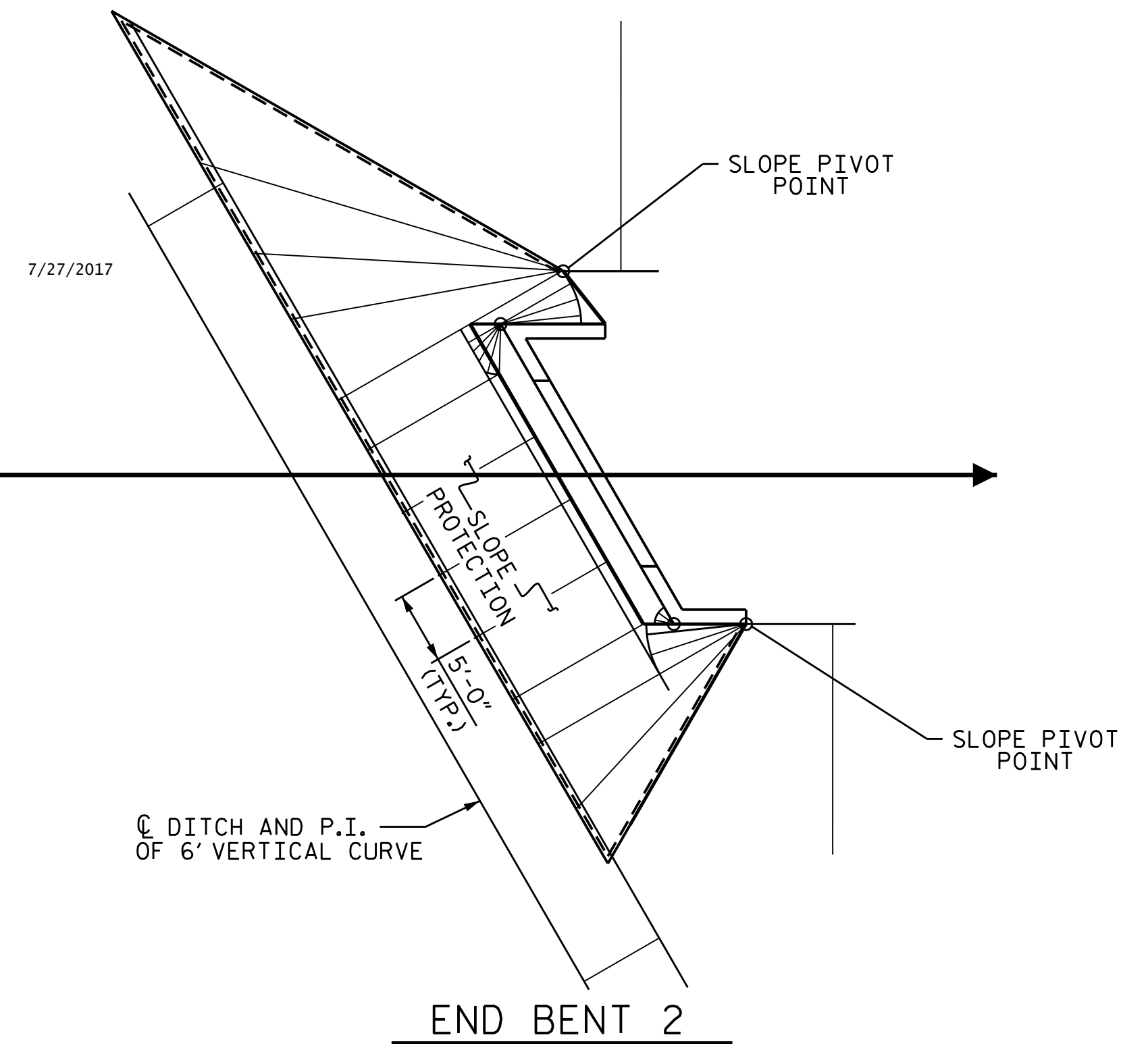
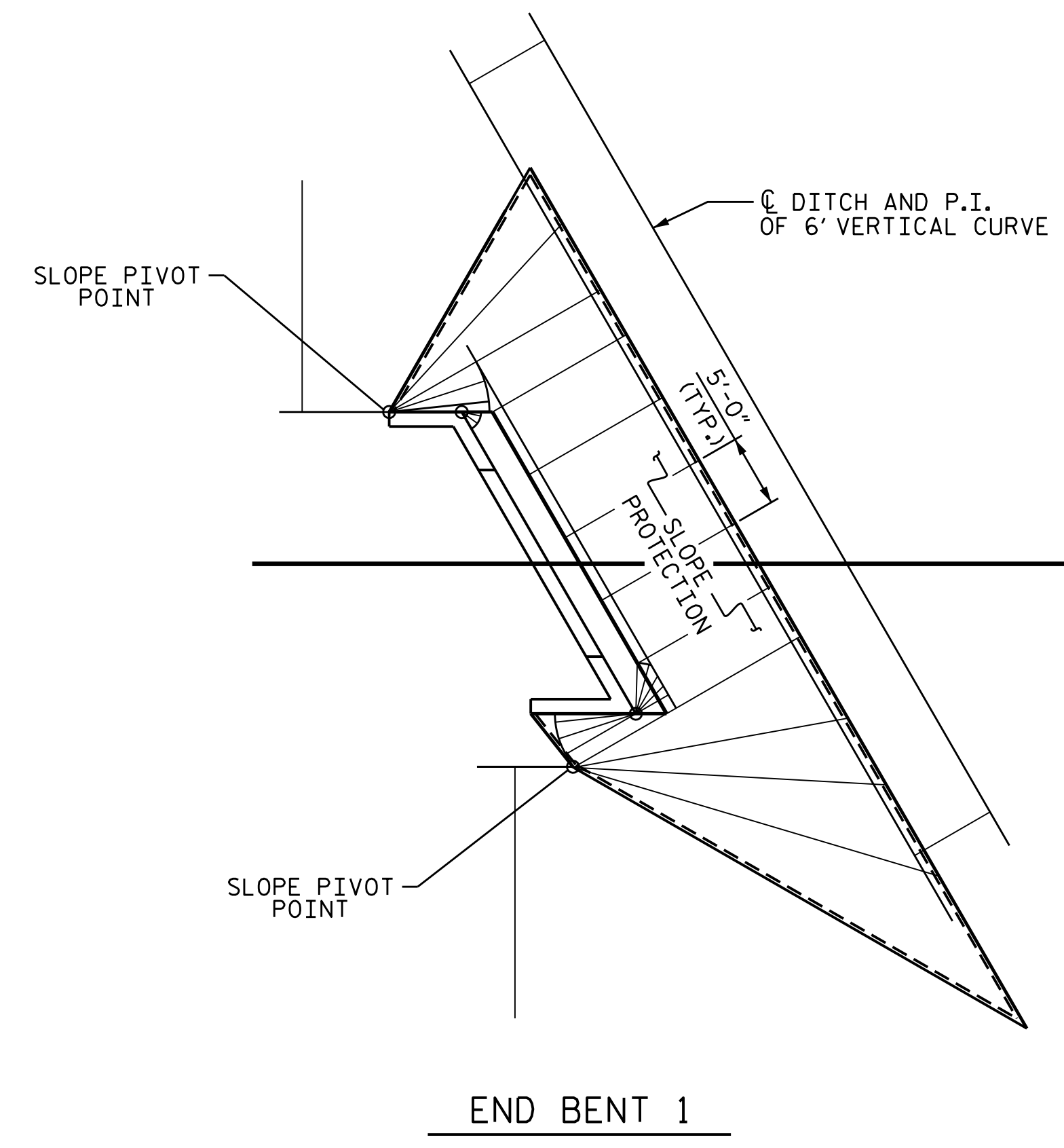

PLAN - CONCRETE PLACEMENT

PROJECT NO. U-2579C
FORSYTH COUNTY
 STATION: 21+27.27 -Y2-
 SHEET 2 OF 2

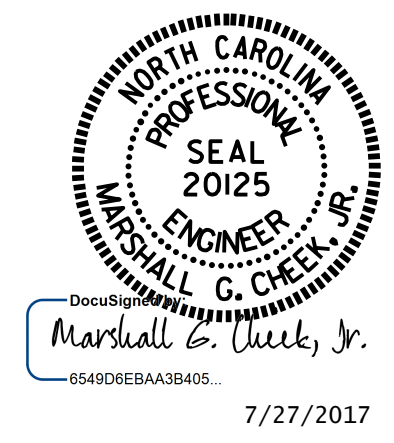

STATE OF NORTH CAROLINA
 DEPARTMENT OF TRANSPORTATION
 RALEIGH
 STANDARD
 SLOPE PROTECTION
 DETAILS

ASSEMBLED BY : H. T. BARBOUR	DATE : 1-23-17
CHECKED BY : T. L. AVERETTE	DATE : 2-21-17
DRAWN BY : WJH 10/88	REV. 5/1/06 TLA/GM
CHECKED BY : FCJ 10/88	REV. 10/1/11 MAA/GM
	REV. 1/16 MAA/TMG

DOCUMENT NOT CONSIDERED
 FINAL UNLESS ALL
 SIGNATURES COMPLETED

REVISIONS						SHEET NO.	
NO.	BY:	DATE:	NO.	BY:	DATE:	S2-29	
1			3			TOTAL SHEETS 30	
2			4				

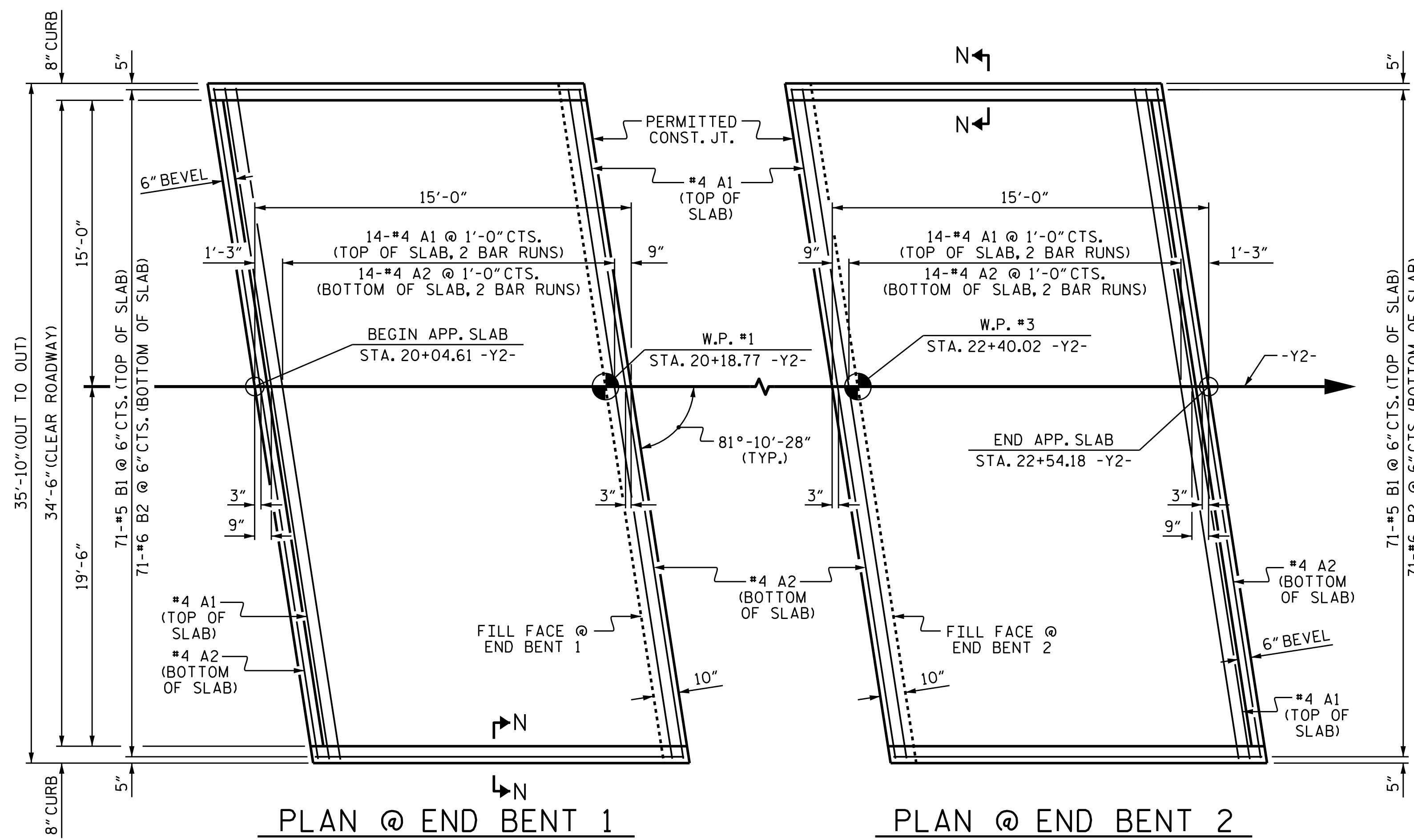

PLAN @ END BENT 1 PLAN @ END BENT 2

DIMENSIONS SHOWN ARE TYPICAL FOR BOTH APPROACH SLABS.

NOTES

THE APPROACH SLAB MAY BE CAST MONOLITHICALLY WITH THE END BENT DIAPHRAGM AND THE END SECTION OF THE BRIDGE DECK NEAR THE INTEGRAL END BENT.

FOR REINFORCED BRIDGE APPROACH FILL FABRIC WALL INCLUDING GEOTEXTILE, IMPERMEABLE GEOMEMBRANE, 4" Ø DRAINAGE PIPE, #78M STONE, WELDED WIRE FORM, AND SELECT MATERIAL, SEE ROADWAY PLANS.

AREA BETWEEN THE WINGWALL AND APPROACH SLAB SHALL BE GRADED TO DRAIN THE WATER AWAY FROM THE FILL FACE OF THE BRIDGE AND SHALL BE PAVED. SEE ROADWAY PLANS.

THE JOINT OPENING AT THE APPROACH SLAB/DECK INTERFACE SHALL BE SAWS NOT MORE THAN 12 HOURS AFTER THE APPROACH SLAB IS CAST. THE JOINT SHALL BE CLEANED OF ALL DEBRIS BEFORE THE SEALANT IS APPLIED. THE JOINT SEALER MATERIAL SHALL CONFORM TO THE REQUIREMENTS OF SECTION 1028-3 OF THE STANDARD SPECIFICATIONS.

BILL OF MATERIAL
FOR ONE APPROACH SLAB (2 REQ'D)

BAR	NO.	SIZE	TYPE	LENGTH	WEIGHT
* A1	32	#4	STR	19'-0"	406
A2	32	#4	STR	18'-10"	403
* B1	71	#5	STR	14'-1"	1043
B2	71	#6	STR	14'-7"	1555
REINFORCING STEEL				LBS.	1,958
* EPOXY COATED REINFORCING STEEL				LBS.	1,449
CLASS AA CONCRETE				C. Y.	23.2

SPLICE LENGTH

BAR SIZE	EPOXY COATED	UNCOATED
#4	2'-0"	1'-9"

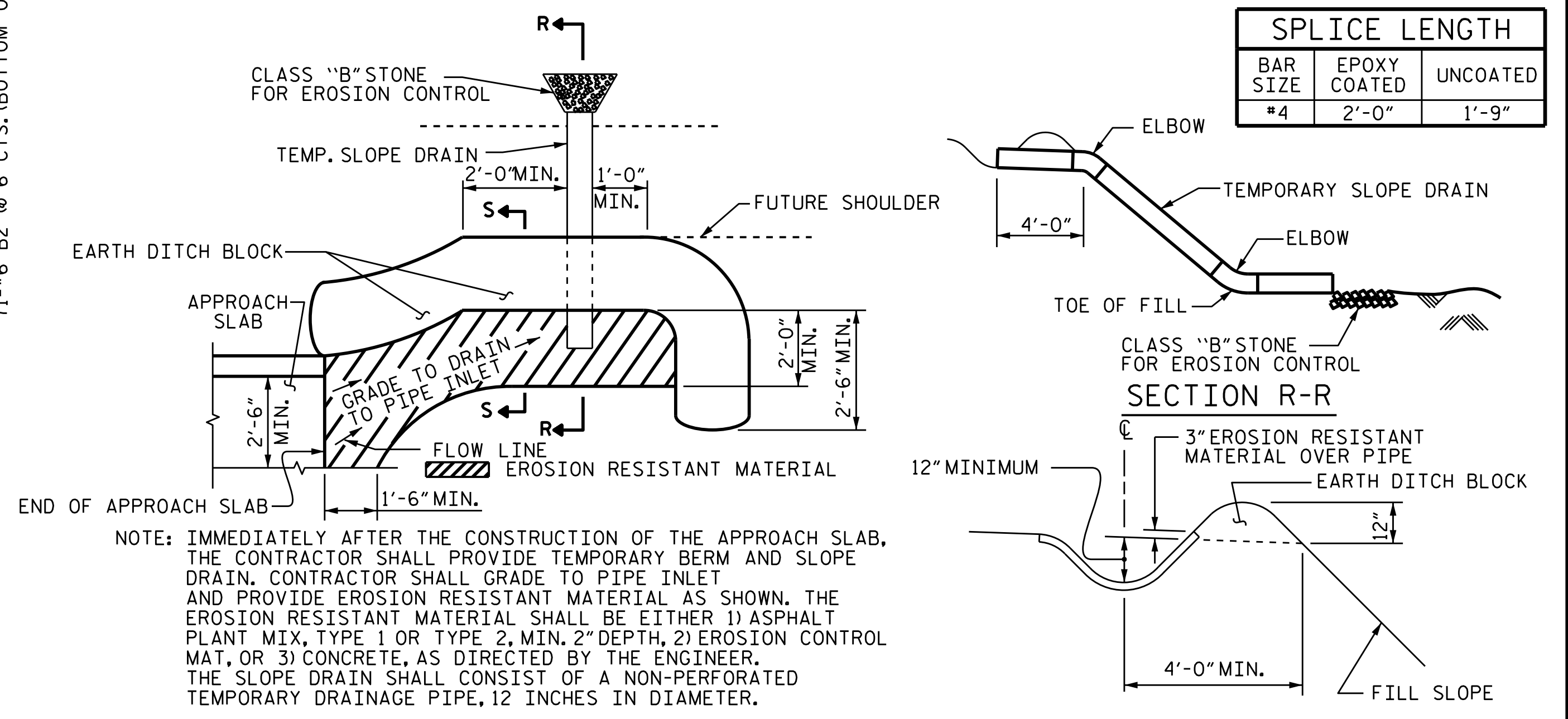

TEMPORARY BERM AND SLOPE DRAIN DETAILS

(TO BE USED WHEN SHOULDER BERM GUTTER IS REQUIRED)

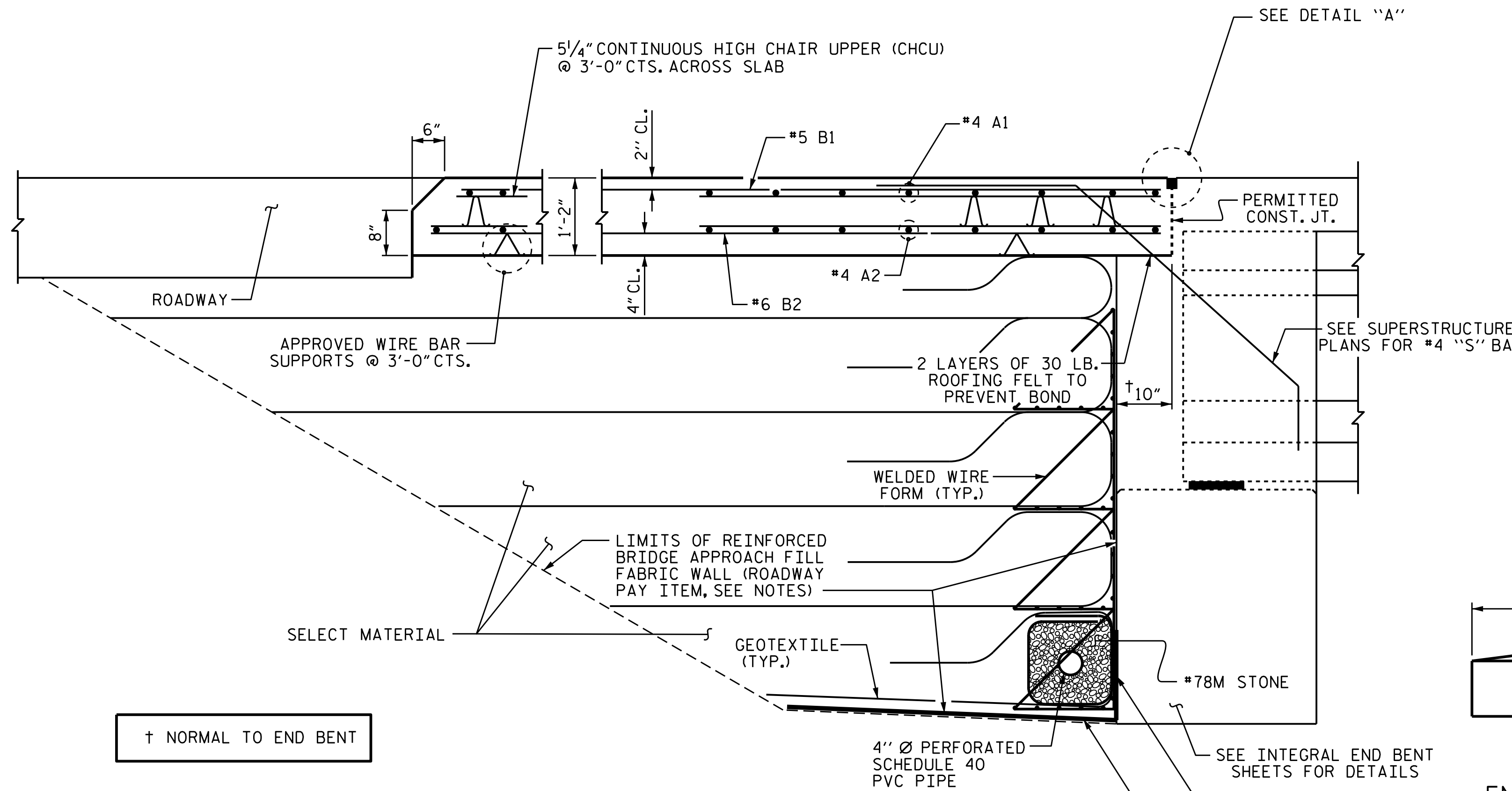

SECTION THRU SLAB

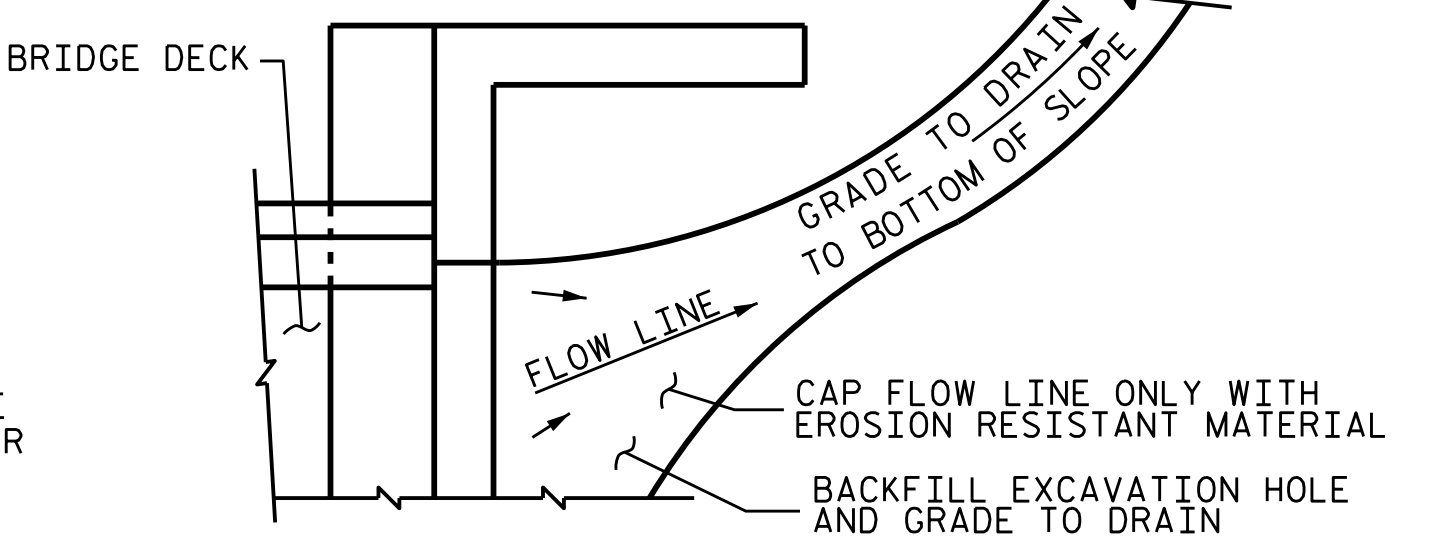

NOTE: IF THE APPROACH SLAB IS NOT CONSTRUCTED IMMEDIATELY AFTER THE BACKFILLING OF THE END BENT EXCAVATION, GRADE TO DRAIN TO THE BOTTOM OF THE SLOPE AND PROVIDE EROSION RESISTANT MATERIAL, SUCH AS FIBERGLASS ROVING OR AS DIRECTED BY THE ENGINEER TO PREVENT SOIL EROSION AND TO PROTECT THE AREA ADJACENT TO THE STRUCTURE. THE CONTRACTOR WILL BE REQUIRED TO REMOVE THESE MATERIALS PRIOR TO CONSTRUCTION OF THE APPROACH SLAB.

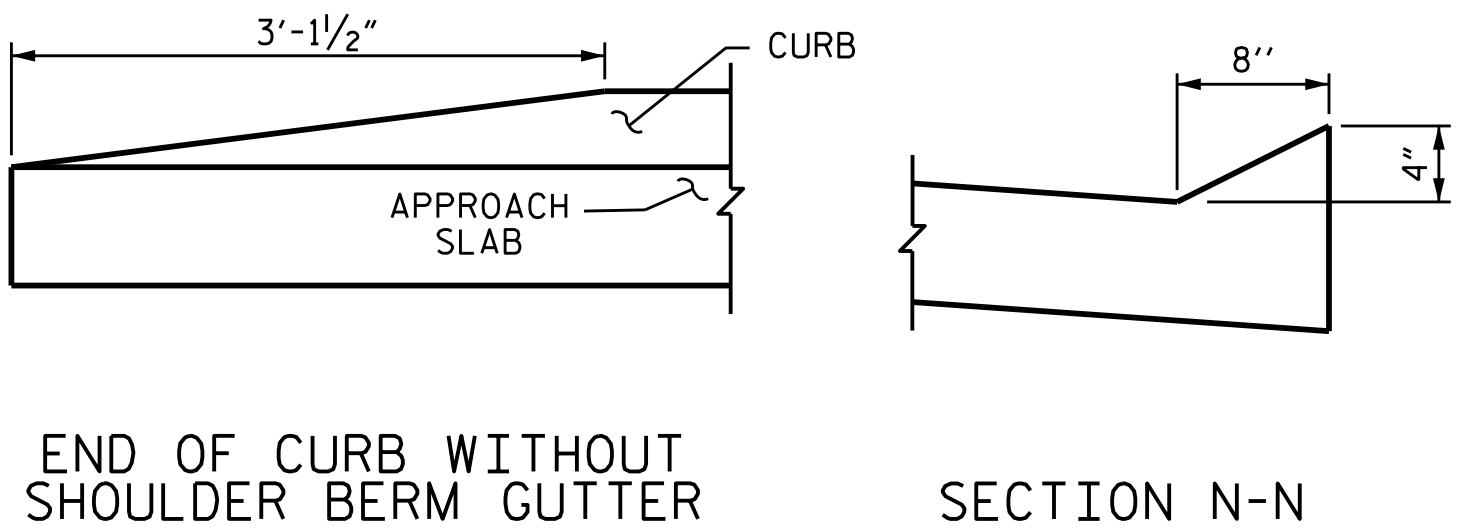

END OF CURB WITHOUT SHOULDER BERM GUTTER SECTION N-N

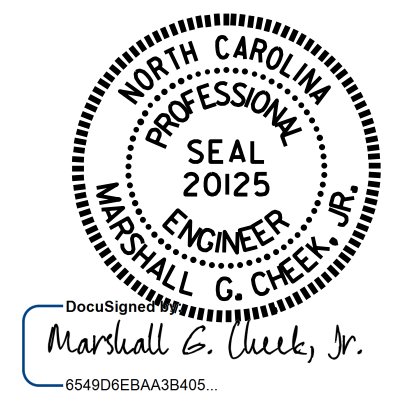

PROJECT NO. U-2579C
FORSYTH COUNTY
STATION: 21+27.27 -Y2-

STATE OF NORTH CAROLINA
DEPARTMENT OF TRANSPORTATION
RALEIGH
STANDARD
BRIDGE APPROACH SLAB
FOR INTEGRAL
ABUTMENT

REVISIONS

NO.	BY:	DATE:	NO.	BY:	DATE:
1			3		
2			4		

SHEET NO. S2-30
TOTAL SHEETS 30

ASSEMBLED BY: J. K. BOWLES DATE: 4/25/16
CHECKED BY: M. K. BEARD DATE: 7/27/16

DRAWN BY: TLA 10/05 MAA/GM
CHECKED BY: GM 5/06 REV. 10/1/11 MAA/GM
REV. 12/21/11 MAA/GM
REV. 6/13 MAA/GM

DOCUMENT NOT CONSIDERED FINAL UNLESS ALL SIGNATURES COMPLETED

STR. #2 STD. NO. BAS5

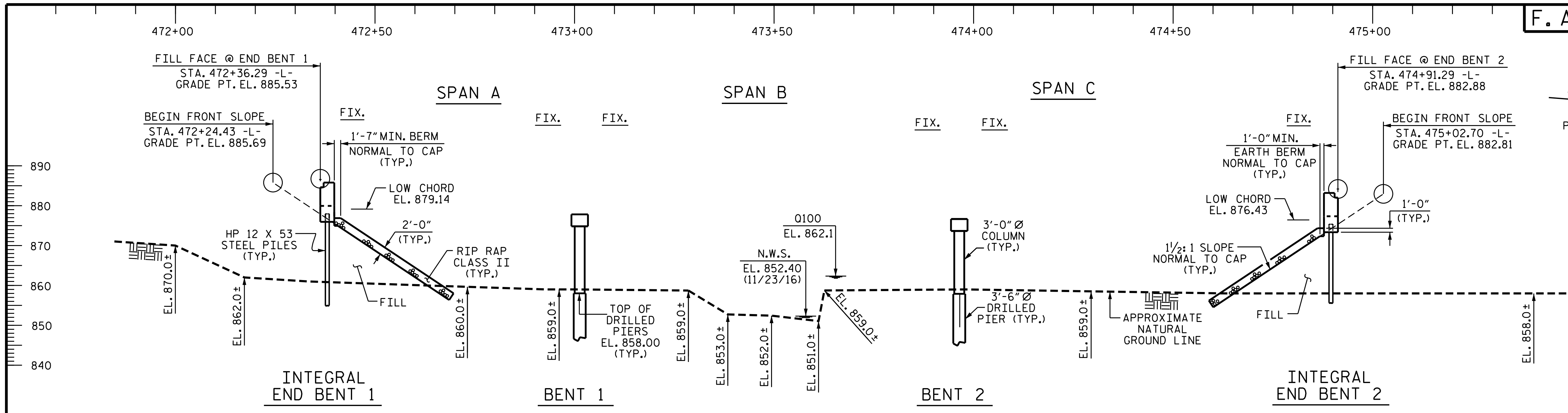

GRADE DATA

(-)-1.5597% (+)-1.3500%

PI STA. = 477+00.00 -L-
 EL = 878.24
 L = 1,050'

SECTION ALONG LEFT LANE CONTROL LINE

SECTIONS AT END BENTS AND BENTS ARE TAKEN AT RIGHT ANGLES

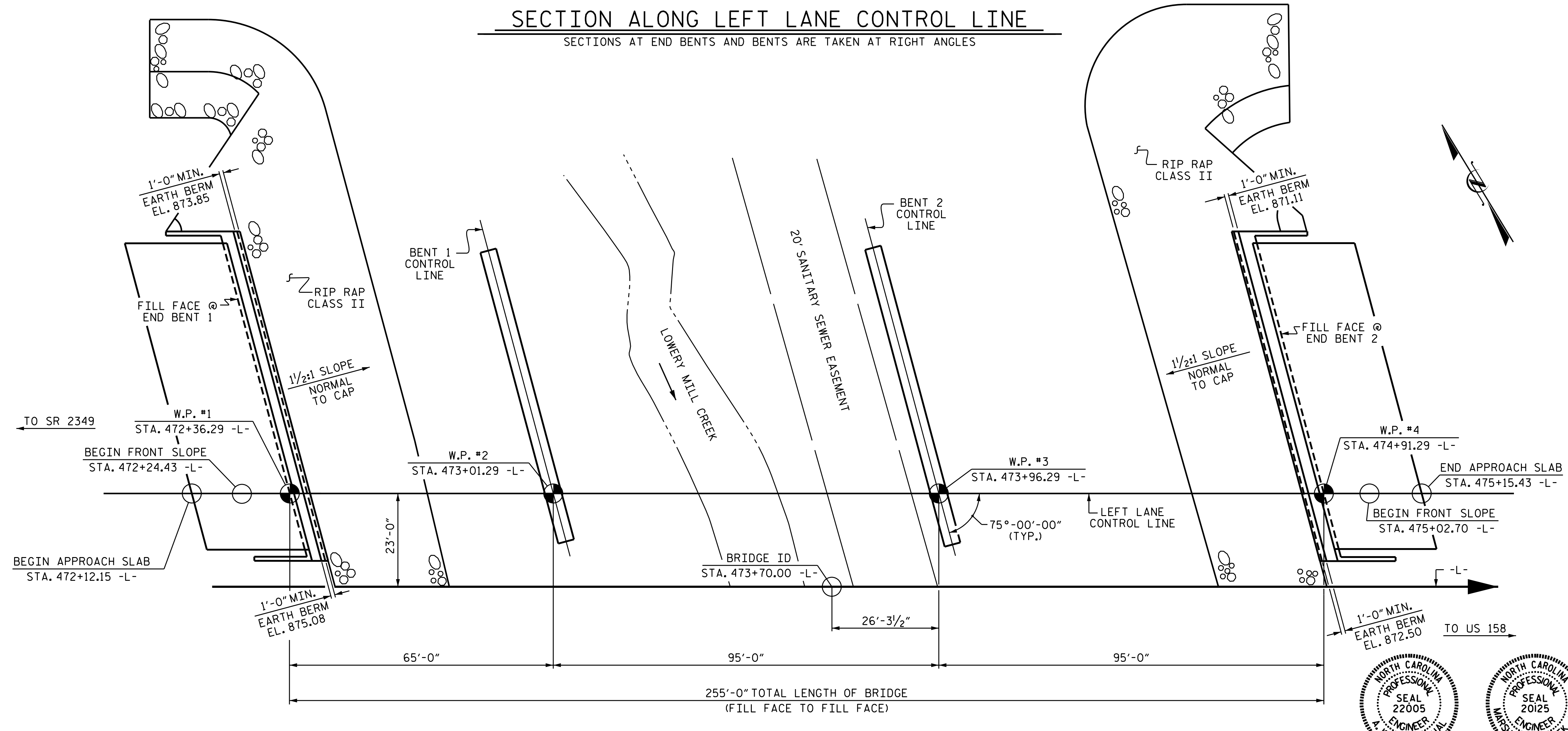

PLAN

PILES, COLUMNS, AND DRILLED PIERS ARE NOT SHOWN FOR CLARITY.

I HEREBY CERTIFY THESE PLANS ARE THE AS-BUILT PLANS

PROJECT NO. U-2579C
FORSYTH COUNTY
 STATION: 473+70.00 -L-

SHEET 1 OF 3 BRIDGE NO. 702

STATE OF NORTH CAROLINA
 DEPARTMENT OF TRANSPORTATION
 RALEIGH
GENERAL DRAWING
 FOR BRIDGE OVER
 LOWERY MILL CREEK
 ON WINSTON-SALEM BELTWAY
 BETWEEN SR 2381 AND US 158
 (LEFT LANE)



DRAWN BY : M.K. BEARD DATE : 9/19/16
 CHECKED BY : H. T. BARBOUR DATE : 3/8/17
 DESIGN ENGINEER OF RECORD : H.A. LOCKLEAR DATE : 6/2017

DOCUMENT NOT CONSIDERED FINAL UNLESS ALL SIGNATURES COMPLETED

REVISIONS						SHEET NO.
NO.	BY:	DATE:	NO.	BY:	DATE:	S3-1
1			3			TOTAL SHEETS
2			4			33

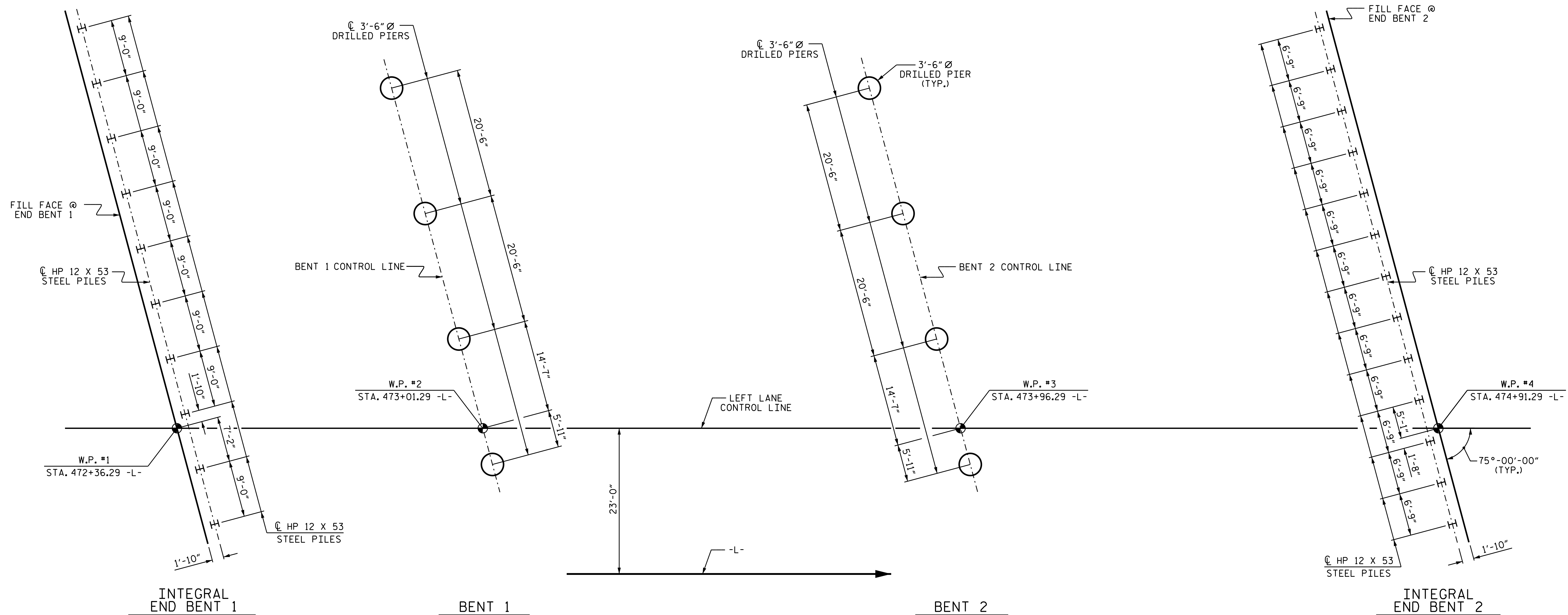

FOUNDATION LAYOUT

DIMENSIONS LOCATING PILES AND DRILLED PIERS ARE SHOWN TO THE CENTERLINE OF PILES AND DRILLED PIERS

NOTES

- FOR PILES, SEE GEOTECHNICAL SPECIAL PROVISIONS AND SECTION 450 OF THE STANDARD SPECIFICATIONS.
- PILES AT END BENT 1 ARE DESIGNED FOR A FACTORED RESISTANCE OF 120 TONS PER PILE.
- DRIVE PILES AT END BENT 1 TO A REQUIRED DRIVING RESISTANCE OF 200 TONS PER PILE.
- PILES AT END BENT 2 ARE DESIGNED FOR A FACTORED RESISTANCE OF 105 TONS PER PILE.
- DRIVE PILES AT END BENT 2 TO A REQUIRED DRIVING RESISTANCE OF 175 TONS PER PILE.
- DO NOT BEGIN WORK AT END BENT 1 AND END BENT 2 UNTIL FILL HAS BEEN PLACED.
- TESTING PILES WITH THE PDA DURING DRIVING, RESTRIKING OR REDRIVING MAY BE REQUIRED. THE ENGINEER WILL DETERMINE THE NEED FOR PDA TESTING. FOR PDA TESTING, SEE SECTION 450 OF THE STANDARD SPECIFICATIONS.
- SEE ROADWAY PLANS AND SPECIAL PROVISIONS FOR THE SETTLEMENT GAUGES REQUIRED AT END BENT 2.
- OBSERVE A 4 MONTH WAITING PERIOD AFTER CONSTRUCTING THE EMBANKMENTS TO WITHIN 2 FT. OF FINISHED GRADE BEFORE BEGINNING END BENT CONSTRUCTION AT END BENT 2. FOR BRIDGE WAITING PERIODS, SEE ROADWAY PLANS AND SPECIAL PROVISIONS.
- FOR DRILLED PIERS, SEE GEOTECHNICAL SPECIAL PROVISIONS AND SECTION 411 OF THE STANDARD SPECIFICATIONS.
- DRILLED PIERS AT BENT 1 ARE DESIGNED FOR A FACTORED RESISTANCE OF 605 TONS PER PIER.

- PERMANENT STEEL CASINGS MAY BE REQUIRED FOR DRILLED PIERS AT BENT 1 AND BENT 2. IF REQUIRED, DO NOT EXTEND PERMANENT CASINGS BELOW ELEVATION 850.00 WITHOUT PRIOR APPROVAL FROM THE ENGINEER. THE ENGINEER WILL DETERMINE THE NEED FOR PERMANENT CASINGS.
- INSTALL DRILLED PIERS AT BENT 1 TO A TIP ELEVATION NO HIGHER THAN 810.00 (LT) AND 798.00 (RT) AND WITH A PENETRATION OF AT LEAST 17.5 FT. INTO WEATHERED ROCK/CRYSTALLINE ROCK.
- DRILLED PIERS AT BENT 2 ARE DESIGNED FOR A FACTORED RESISTANCE OF 695 TONS PER PIER.
- INSTALL DRILLED PIERS AT BENT 2 TO A TIP ELEVATION NO HIGHER THAN 812.00 (LT) AND 810.00 (RT) AND WITH A PENETRATION OF AT LEAST 17.5 FT. INTO WEATHERED ROCK/CRYSTALLINE ROCK.
- SLURRY CONSTRUCTION IS REQUIRED FOR DRILLED PIERS AT BENT 1 AND BENT 2.
- SPT IS REQUIRED FOR DRILLED PIERS AT BENT 1 AND BENT 2. THE REQUIRED N60 SPT VALUE IS 100 BLOWS IN THE FIRST FOOT OF THE DRIVE. FOR SPT TESTING, SEE SECTION 411 OF THE STANDARD SPECIFICATIONS.
- SID INSPECTIONS MAY BE REQUIRED FOR DRILLED PIERS. THE ENGINEER WILL DETERMINE THE NEED FOR SID INSPECTIONS. FOR SID INSPECTIONS, SEE SECTION 411 OF THE STANDARD SPECIFICATIONS.
- CSL TUBES ARE REQUIRED AND CSL TESTING MAY BE REQUIRED FOR DRILLED PIERS. THE ENGINEER WILL DETERMINE THE NEED FOR CSL TESTING. FOR CSL TESTING, SEE SECTION 411 OF THE STANDARD SPECIFICATIONS.
- THE SCOUR CRITICAL ELEVATION FOR BENT 1 AND BENT 2 IS ELEVATION 845.00. SCOUR CRITICAL ELEVATIONS ARE USED TO MONITOR POSSIBLE SCOUR PROBLEMS DURING THE LIFE OF THE STRUCTURE.

DRAWN BY : M.K. BEARD DATE : 9/26/16
 CHECKED BY : H.T. BARBOUR DATE : 3/8/17
 DESIGN ENGINEER OF RECORD: H.A. LOCKLEAR DATE : 6/2017

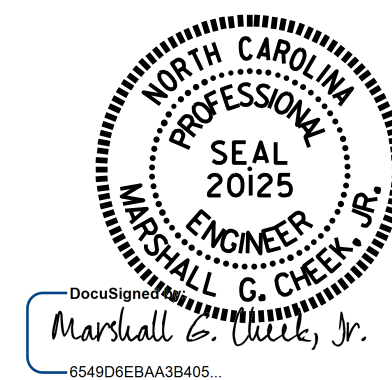

PROJECT NO. U-2579C
 FORSYTH COUNTY
 STATION: 473+70.00 -L-

SHEET 2 OF 3
 STATE OF NORTH CAROLINA
 DEPARTMENT OF TRANSPORTATION
 RALEIGH
GENERAL DRAWING
 FOR BRIDGE OVER
 LOWERY MILL CREEK
 ON WINSTON-SALEM BELTWAY
 BETWEEN SR 2381 AND US 158
 (LEFT LANE)

REVISIONS						SHEET NO.
NO.	BY:	DATE:	NO.	BY:	DATE:	TOTAL SHEETS
1			3			S3-2
2			4			33

DOCUMENT NOT CONSIDERED FINAL UNLESS ALL SIGNATURES COMPLETED

B.M. #8 : R/R SPIKE SET IN BASE OF 36" SWEET GUM AND 70' WEST OF CREEK BANK, 565' LEFT OF STA. 469+22.00 -L-, EL. 864.90

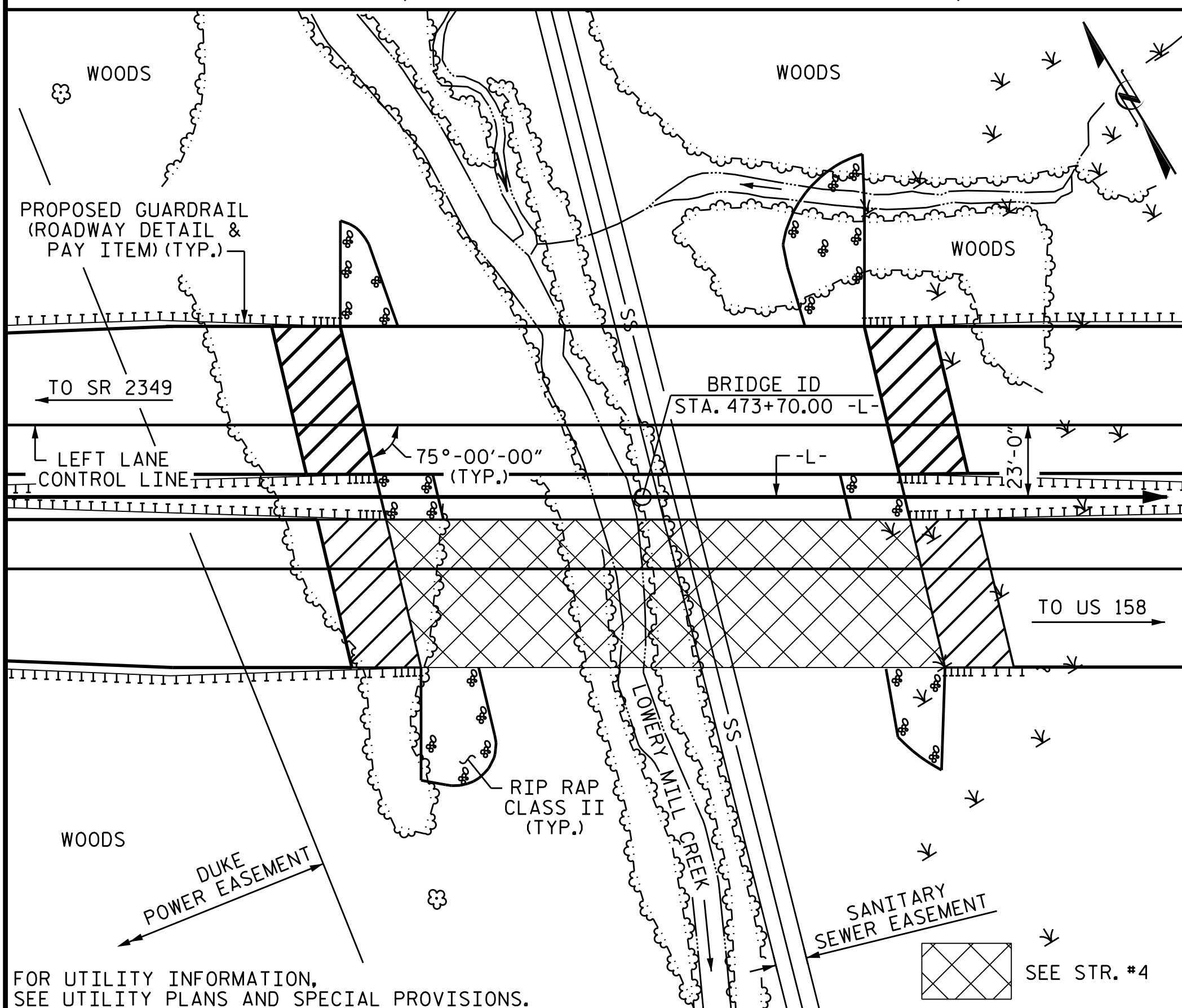

LOCATION SKETCH

NOTES

ASSUMED LIVE LOAD = HL-93 OR ALTERNATE LOADING.
 THIS BRIDGE HAS BEEN DESIGNED IN ACCORDANCE WITH THE AASHTO LRFD BRIDGE DESIGN SPECIFICATIONS.
 THIS BRIDGE IS LOCATED IN SEISMIC ZONE 1.
 FOR OTHER DESIGN DATA AND GENERAL NOTES, SEE SHEET SN.
 FOR SUBMITTAL OF WORKING DRAWINGS, SEE SPECIAL PROVISIONS.
 FOR FALSEWORK AND FORMWORK, SEE SPECIAL PROVISIONS.
 FOR CRANE SAFETY, SEE SPECIAL PROVISIONS.
 FOR GROUT FOR STRUCTURES, SEE SPECIAL PROVISIONS.

THE CONTRACTOR SHALL PROVIDE INDEPENDENT ASSURANCE SAMPLES OF REINFORCING STEEL AS FOLLOWS: FOR PROJECTS REQUIRING UP TO 400 TONS OF REINFORCING STEEL, ONE 30 INCH SAMPLE OF EACH SIZE BAR USED, AND FOR PROJECTS REQUIRING OVER 400 TONS OF REINFORCING STEEL, TWO 30 INCH SAMPLES OF EACH SIZE BAR USED. THE BARS FROM WHICH THE SAMPLES ARE TAKEN MUST THEN BE SPLICED WITH REPLACEMENT BARS OF THE SIZE AND LENGTH OF THE SAMPLE, PLUS A MINIMUM LAP SPLICE OF THIRTY BAR DIAMETERS. PAYMENT FOR THE SAMPLES OF REINFORCING STEEL SHALL BE CONSIDERED INCIDENTAL TO VARIOUS PAY ITEMS.

PRESTRESSED CONCRETE DECK PANELS MAY BE USED IN LIEU OF METAL STAY-IN-PLACE FORMS IN ACCORDANCE WITH ARTICLE 420-3 OF THE STANDARD SPECIFICATIONS.

REMOVABLE FORMS MAY BE USED IN LIEU OF METAL STAY-IN-PLACE FORMS IN ACCORDANCE WITH ARTICLE 420-3 OF THE STANDARD SPECIFICATIONS.

THIS STRUCTURE HAS BEEN DESIGNED IN ACCORDANCE WITH "HEC 18-EVALUATING SCOUR AT BRIDGES."

NEEDLE BEAMS WILL NOT BE ALLOWED UNLESS OTHERWISE CALLED FOR ON THE PLANS OR APPROVED BY THE ENGINEER.

THE CLASS AA CONCRETE IN THE BRIDGE DECK SHALL CONTAIN FLY ASH OR GROUND GRANULATED BLAST FURNACE SLAG AT THE SUBSTITUTION RATE SPECIFIED IN ARTICLE 1024-1 AND IN ACCORDANCE WITH ARTICLES 1024-5 AND 1024-6 OF THE STANDARD SPECIFICATIONS. NO PAYMENT WILL BE MADE FOR THIS SUBSTITUTION AS IT IS CONSIDERED INCIDENTAL TO THE COST OF THE REINFORCED CONCRETE DECK SLAB.

FOR EROSION CONTROL MEASURES, SEE EROSION CONTROL PLANS.

FOR PLACING LOAD ON STRUCTURE MEMBERS, SEE SPECIAL PROVISIONS.

FOR EMBEDDED CLIPS FOR PRESTRESSED CONCRETE GIRDERS, SEE SPECIAL PROVISIONS.

HYDRAULIC DATA

DESIGN DISCHARGE	= 1,900 C.F.S.
FREQUENCY OF DESIGN FLOOD	= 50 YRS.
DESIGN HIGH WATER ELEVATION	= 861.8
DRAINAGE AREA	= 2.4 SQ. MI.
BASE DISCHARGE (Q100)	= 2,230 C.F.S.
BASE HIGH WATER ELEVATION	= 862.1

OVERTOPPING DATA

OVERTOPPING DISCHARGE	= 2,960+ C.F.S.
FREQUENCY OF OVERTOPPING FLOOD	= 500+ YRS.
OVERTOPPING FLOOD ELEVATION	= 882.0
SAG @ STA. 477+34.84 -L-	

TOTAL BILL OF MATERIAL

	3'-6" Ø DRILLED PIERS IN SOIL	3'-6" Ø DRILLED PIERS NOT IN SOIL	PERMANENT STEEL CASING FOR 3'-6" Ø DRILLED PIERS	PDA TESTING	SID INSPECTIONS	SPT TESTING	CSL TESTING	REINFORCED CONCRETE DECK SLAB	GROOVING BRIDGE FLOORS	CLASS A CONCRETE	BRIDGE APPROACH SLABS	REINFORCING STEEL	SPIRAL COLUMN REINFORCING STEEL	54" PRESTRESSED CONCRETE GIRDERS	PILE DRIVING EQUIPMENT SETUP FOR HP 12 X 53 STEEL PILES	HP 12 X 53 STEEL PILES	CONCRETE BARRIER RAIL	RIP RAP CLASS II (2'-0" THICK)	GEOTEXTILE FOR DRAINAGE	ELASTOMERIC BEARINGS			
	LIN. FT.	LIN. FT.	LIN. FT.	EA.	EA.	EA.	EA.	SO. FT.	SO. FT.	CU. YDS.	LUMP SUM	LBS.	LBS.	NO.	LIN. FT.	EA.	NO.	LIN. FT.	LIN. FT.	TONS	SO. YDS.	LUMP SUM	
SUPERSTRUCTURE								19,189	20,783		LUMP SUM			27	2,258.63					506.55		LUMP SUM	
END BENT 1										59.0		6,468				10	10	675			530	590	
BENT 1	154.00	62.00	32.00			4				62.7		30,369	5,970										
BENT 2	108.00	80.00	32.00			4				66.7		28,337	5,255										
END BENT 2										59.5		6,489			13	13	750				515	570	
TOTAL	262.00	142.00	64.00	1	1	8	1	19,189	20,783	247.9	LUMP SUM	71,663	11,225	27	2,258.63	23	23	1,425	506.55	1,045	1,160	LUMP SUM	

PROJECT NO. U-2579C
 FORSYTH COUNTY
 STATION: 473+70.00 -L-

SHEET 3 OF 3

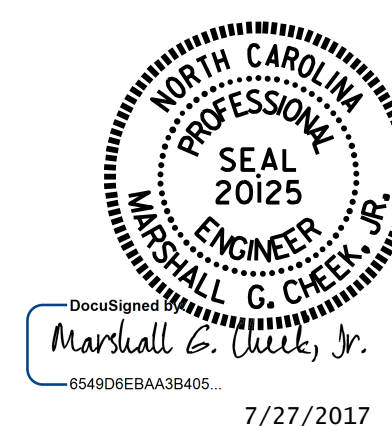

7/27/2017

STATE OF NORTH CAROLINA
 DEPARTMENT OF TRANSPORTATION
 RALEIGH
 GENERAL DRAWING
 FOR BRIDGE OVER
 LOWERY MILL CREEK
 ON WINSTON-SALEM BELTWAY
 BETWEEN SR 2381 AND US 158
 (LEFT LANE)

DRAWN BY : M.K. BEARD DATE : 9/20/16
 CHECKED BY : H.T. BARBOUR DATE : 3/8/17
 DESIGN ENGINEER OF RECORD : H.A. LOCKLEAR DATE : 6/2017

DOCUMENT NOT CONSIDERED FINAL UNLESS ALL SIGNATURES COMPLETED

REVISIONS						SHEET NO.	
NO.	BY:	DATE:	NO.	BY:	DATE:	S3-3	
1			3			TOTAL SHEETS 33	
2			4				

LOAD FACTORS:

DESIGN LOAD RATING FACTORS	LIMIT STATE	γ_{DC}	γ_{DW}
	STRENGTH I	1.25	1.50
	SERVICE III	1.00	1.00

LOAD AND RESISTANCE FACTOR RATING (LRFD) SUMMARY FOR PRESTRESSED CONCRETE GIRDERS																								
LEVEL	VEHICLE	WEIGHT (W) (TONS)	CONTROLLING LOAD RATING #	MINIMUM RATING FACTORS (RF)	TONS = W X RF	STRENGTH I LIMIT STATE										SERVICE III LIMIT STATE								COMMENT NUMBER
						LIVELOAD FACTORS	MOMENT					SHEAR					LIVELOAD FACTORS	MOMENT						
							DISTRIBUTION FACTORS (DF)	RATING FACTOR	SPAN	GIRDER LOCATION	DISTANCE FROM LEFT END OF SPAN (ft)	DISTRIBUTION FACTORS (DF)	RATING FACTOR	SPAN	GIRDER LOCATION	DISTANCE FROM LEFT END OF SPAN (ft)		DISTRIBUTION FACTORS (DF)	RATING FACTOR	SPAN	GIRDER LOCATION	DISTANCE FROM LEFT END OF SPAN (ft)		
DESIGN LOAD RATING	HL-93(Inv)	N/A	①	1.01	--	1.75	0.776	1.02	A	ER	30.988	0.882	1.45	A	I	12.395	0.80	0.776	1.01	B	ER	46.375		
	HL-93(0pr)	N/A	--	1.32	--	1.35	0.776	1.33	A	ER	30.988	0.882	1.88	A	I	12.395	N/A	--	--	--	--	--		
	HS-20(Inv)	36.000	②	1.30	46.860	1.75	0.776	1.31	A	ER	30.988	0.882	1.76	A	I	12.395	0.80	0.776	1.31	A	ER	30.988		
	HS-20(0pr)	36.000	--	1.69	60.745	1.35	0.776	1.69	A	ER	30.988	0.882	2.28	A	I	12.395	N/A	--	--	--	--	--		
LEGAL LOAD RATING	SV	SH	12.500	--	3.13	39.167	1.40	0.776	3.87	A	ER	30.988	0.882	5.45	A	I	12.395	0.80	0.776	3.11	A	ER	30.988	
		S3C	21.500	--	1.84	39.512	1.40	0.776	2.27	A	ER	30.988	0.882	3.22	A	I	12.395	0.80	0.776	1.83	A	ER	30.988	
		S3A	22.750	--	1.74	39.665	1.40	0.776	2.15	A	ER	30.988	0.882	3.06	A	I	12.395	0.80	0.776	1.73	A	ER	30.988	
		S4A	26.750	--	1.56	41.702	1.40	0.776	1.92	A	ER	30.988	0.882	2.72	A	I	12.395	0.80	0.776	1.55	A	ER	30.988	
		S5A	30.500	--	1.38	42.110	1.40	0.776	1.70	A	ER	30.988	0.882	2.56	A	I	12.395	0.80	0.776	1.37	A	ER	30.988	
		S6A	34.500	--	1.27	43.734	1.40	0.776	1.57	A	ER	30.988	0.882	2.34	A	I	12.395	0.80	0.776	1.26	A	ER	30.988	
	TTST	S7B	38.500	③	1.16	44.764	1.40	0.776	1.44	A	ER	30.988	0.882	2.25	A	I	12.395	0.80	0.776	1.16	A	ER	30.988	
		S7A	40.000	--	1.17	46.590	1.40	0.776	1.44	A	ER	30.988	0.882	2.37	A	I	12.395	0.80	0.776	1.16	A	ER	30.988	
		T4A	28.250	--	1.57	44.261	1.40	0.776	1.93	A	ER	30.988	0.882	2.67	A	I	12.395	0.80	0.776	1.56	A	ER	30.988	
		T5B	32.000	--	1.37	43.935	1.40	0.776	1.70	A	ER	30.988	0.882	2.59	A	I	12.395	0.80	0.776	1.36	A	ER	30.988	
		T6A	36.000	--	1.28	46.024	1.40	0.776	1.58	A	ER	30.988	0.882	2.50	A	I	12.395	0.80	0.776	1.27	A	ER	30.988	
		T7A	40.000	--	1.21	48.183	1.40	0.776	1.49	A	ER	30.988	0.882	2.40	A	I	12.395	0.80	0.776	1.20	A	ER	30.988	
T7B	40.000	--	1.33	53.333	1.40	0.776	1.65	A	ER	30.988	0.882	2.16	A	I	12.395	0.80	0.776	1.32	A	ER	30.988			

NOTES:

MINIMUM RATING FACTORS ARE BASED ON THE STRENGTH I AND SERVICE III LIMIT STATES.
ALLOWABLE STRESSES FOR SERVICE III LIMIT STATE ARE AS REQUIRED FOR DESIGN.

CONTROLLING LOAD RATING

① DESIGN LOAD RATING (HL-93)

② DESIGN LOAD RATING (HS-20)

③ LEGAL LOAD RATING **

** SEE CHART FOR VEHICLE TYPE

GIRDER LOCATION

I - INTERIOR GIRDER
EL - EXTERIOR LEFT GIRDER
ER - EXTERIOR RIGHT GIRDER

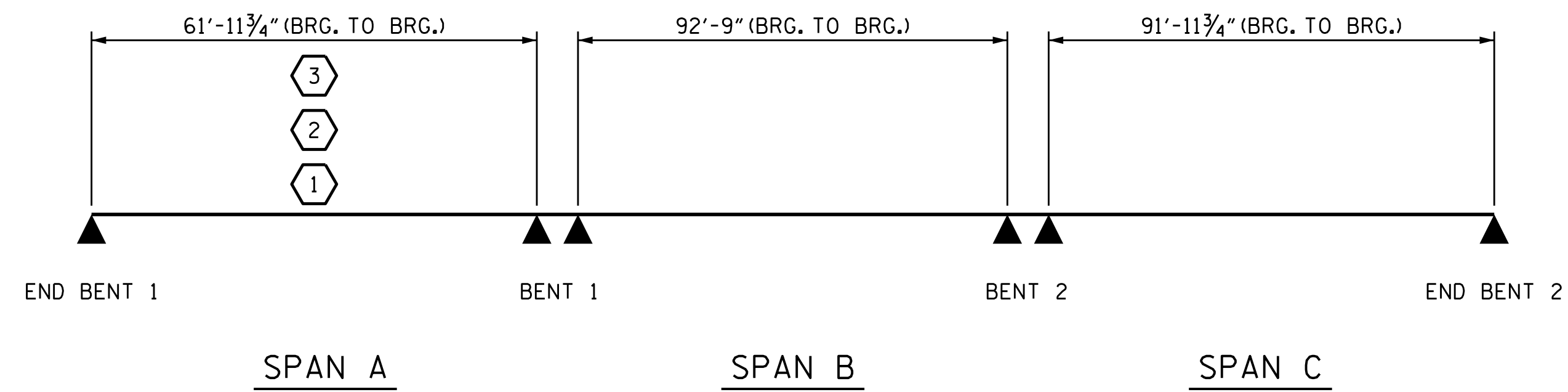

LRFR SUMMARY

PROJECT NO. U-2579C
FORSYTH COUNTY
 STATION: 473+70.00 -L-



STATE OF NORTH CAROLINA
 DEPARTMENT OF TRANSPORTATION
 RALEIGH

STANDARD
 LRFR SUMMARY FOR
 PRESTRESSED
 CONCRETE GIRDERS
 (INTERSTATE TRAFFIC)

ASSEMBLED BY : T. L. AVERETTE	DATE : 3/7/17
CHECKED BY : H. T. BARBOUR	DATE : 3/8/17
DRAWN BY : MAA	1/08
CHECKED BY : GM/DI	2/08
REV. 11/12/08RR	MAA/GM
REV. 10/1/11	MAA/GM

DOCUMENT NOT CONSIDERED FINAL UNLESS ALL SIGNATURES COMPLETED	NO.	BY:	DATE:	NO.	BY:	DATE:	SHEET NO.
	1			3			S3-4
	2			4			TOTAL SHEETS 33

NOTES

PROVIDE 1/4" HIGH BEAM BOLSTERS UPPER AT 4'-0" CTS. ATOP THE METAL STAY-IN-PLACE FORMS TO SUPPORT THE BOTTOM MAT OF 'A' BARS. WHEN USING REMOVABLE FORMS, PROVIDE CONTINUOUS HIGH CHAIRS FOR METAL DECK (C.H.C.M.) @ 4'-0" CTS. WITH A HEIGHT TO SUPPORT THE BOTTOM MAT OF 'A' BARS A CLEAR DISTANCE OF 2 1/2" ABOVE THE TOP OF THE REMOVABLE FORM.

LONGITUDINAL STEEL MAY BE SHIFTED SLIGHTLY, AS NECESSARY, TO AVOID INTERFERENCE WITH STIRRUPS IN PRESTRESSED CONCRETE GIRDERS.

BARRIER RAIL IN A CONTINUOUS UNIT SHALL NOT BE CAST UNTIL ALL SLAB CONCRETE IN THE UNIT HAS BEEN CAST AND HAS REACHED A MINIMUM COMPRESSIVE STRENGTH OF 3,000 PSI.

* FOR INTERMEDIATE STEEL DIAPHRAGM DETAILS, SEE "INTERMEDIATE STEEL DIAPHRAGMS FOR TYPE IV PRESTRESSED CONCRETE GIRDERS" SHEET.

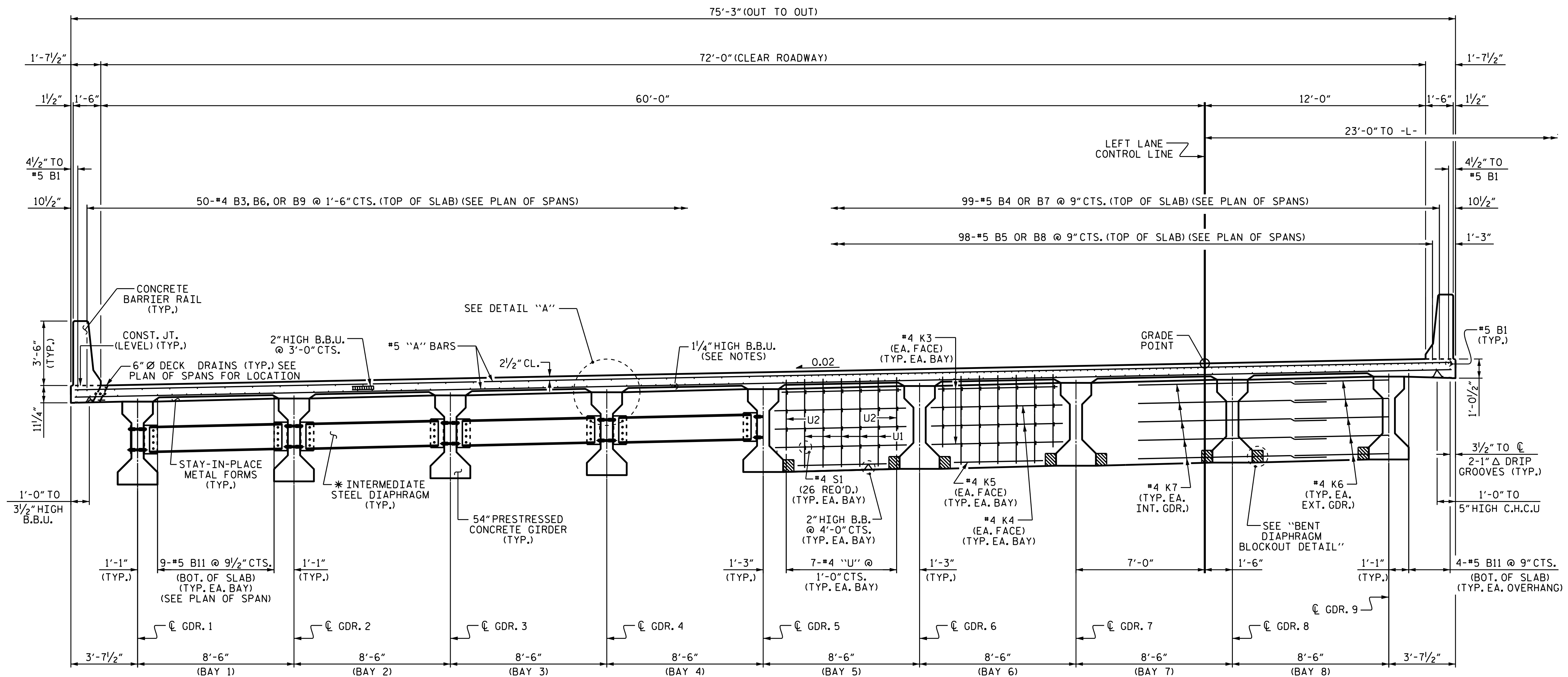

TYPICAL SECTION
(SHOWING INTERMEDIATE DIAPHRAGMS)

TYPICAL SECTION
(SHOWING BENT DIAPHRAGMS)

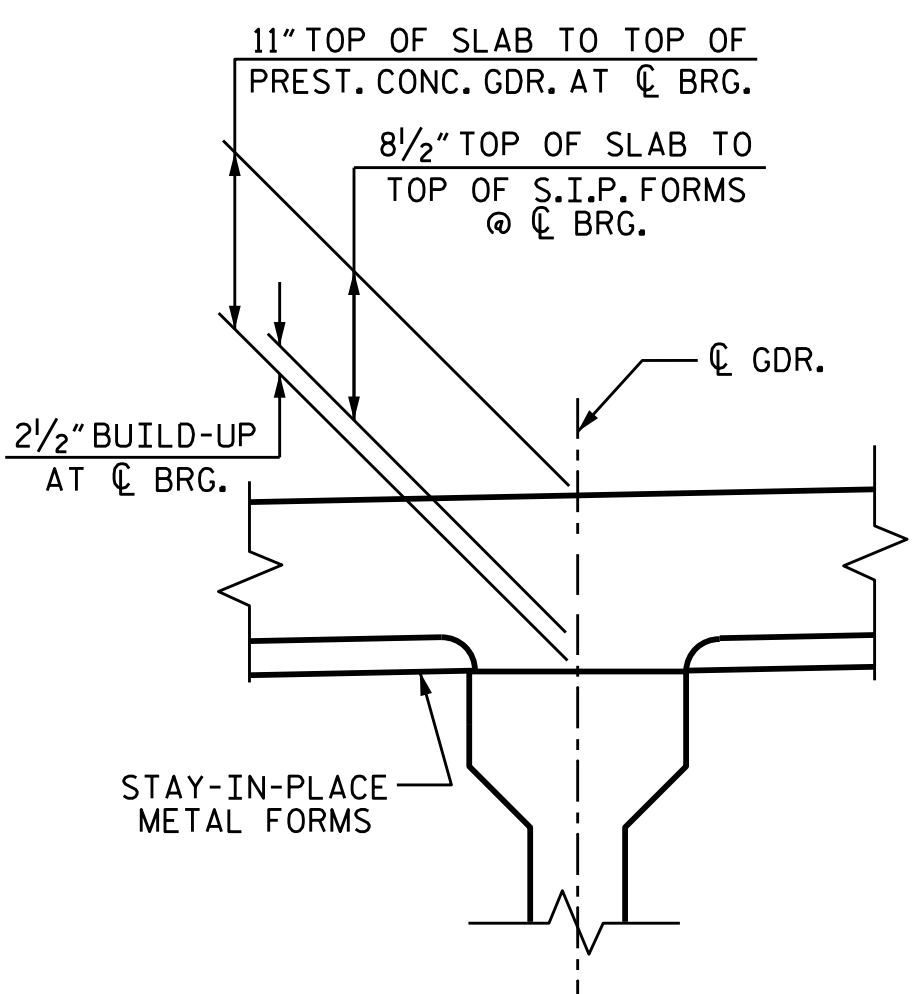

DETAIL "A"

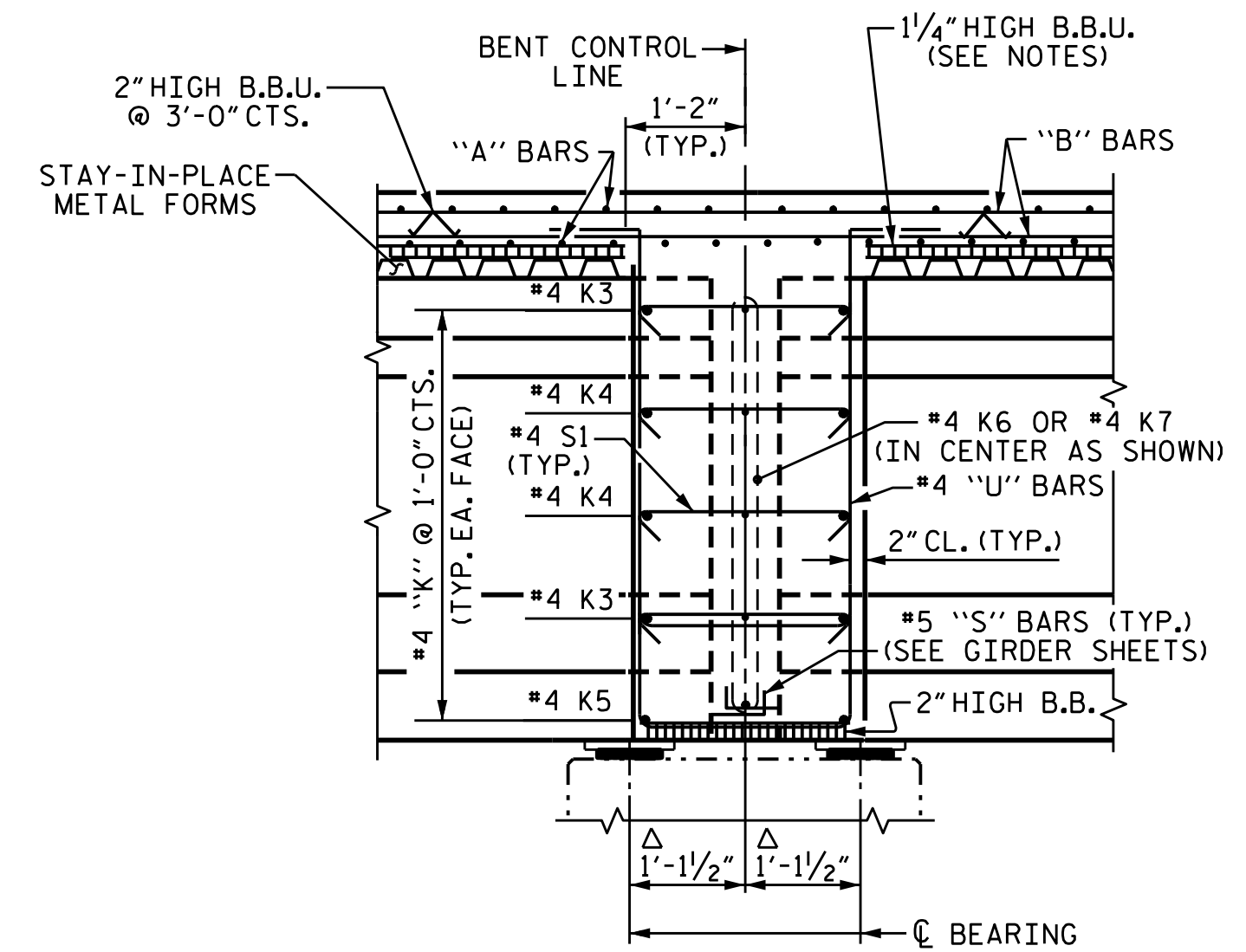

SECTION THROUGH BENT DIAPHRAGM

Δ MEASURED ALONG GDR.

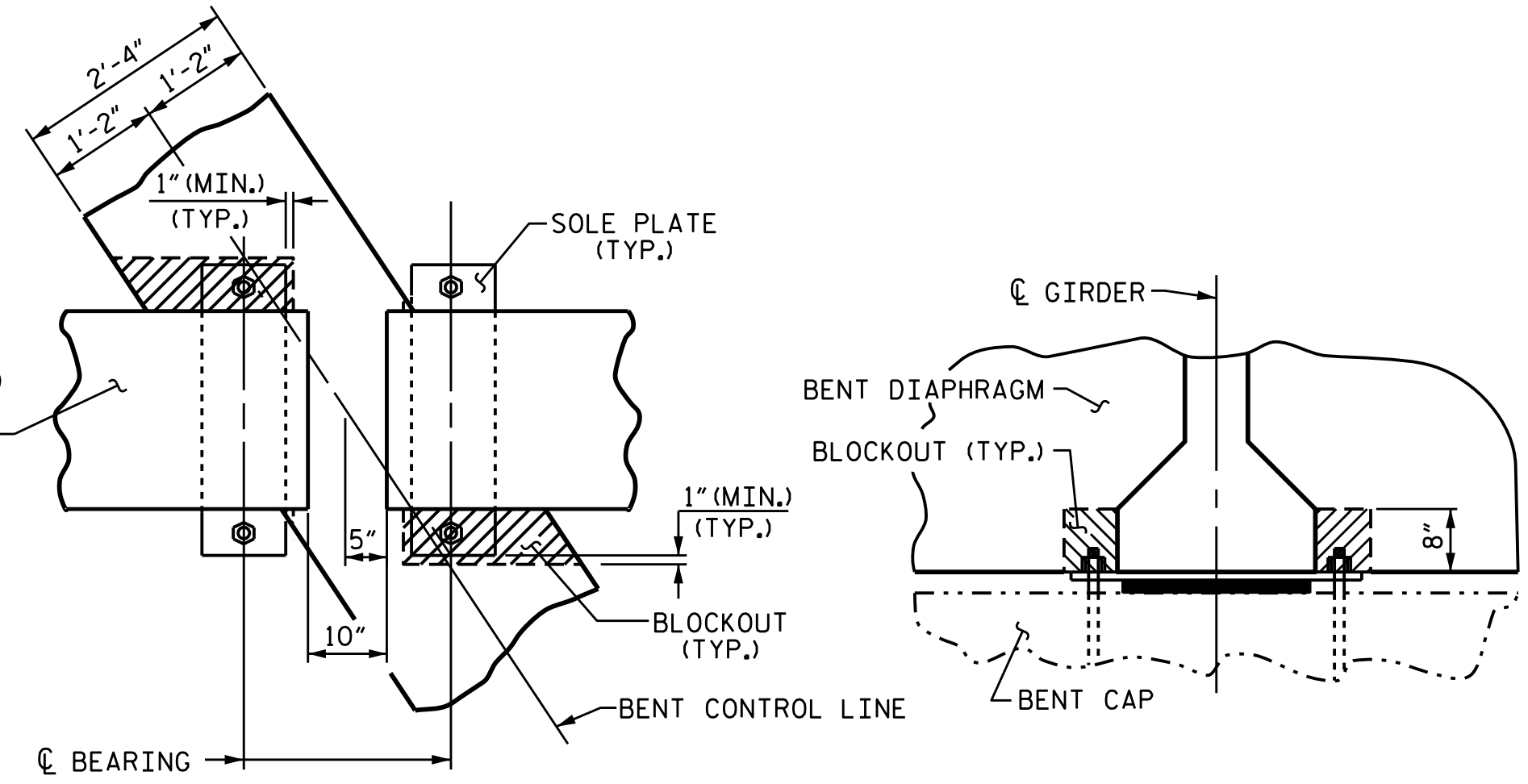

PLAN
#5 S7 BARS NOT SHOWN

SECTION

BENT DIAPHRAGM BLOCKOUT DETAIL

PROJECT NO. U-2579C
FORSYTH COUNTY
STATION: 473+70.00 -L-

SHEET 1 OF 2

STATE OF NORTH CAROLINA
DEPARTMENT OF TRANSPORTATION
RALEIGH
SUPERSTRUCTURE
TYPICAL SECTION
(LEFT LANE)

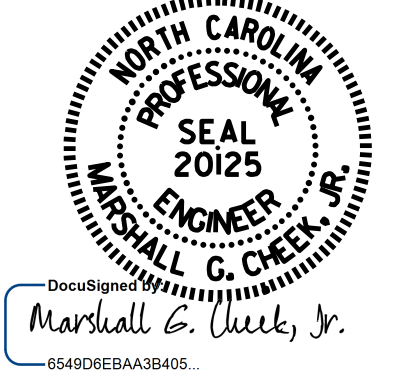

DRAWN BY: J. K. BOWLES DATE: 1/11/16
CHECKED BY: N. D'AIUTO DATE: 3/17/16
DESIGN ENGINEER OF RECORD: H. A. LOCKLEAR DATE: 3/17/16

DOCUMENT NOT CONSIDERED FINAL UNLESS ALL SIGNATURES COMPLETED

REVISIONS						SHEET NO.	
NO.	BY:	DATE:	NO.	BY:	DATE:	S3-5	
1			3			TOTAL SHEETS	
2			4			33	

STR. #3

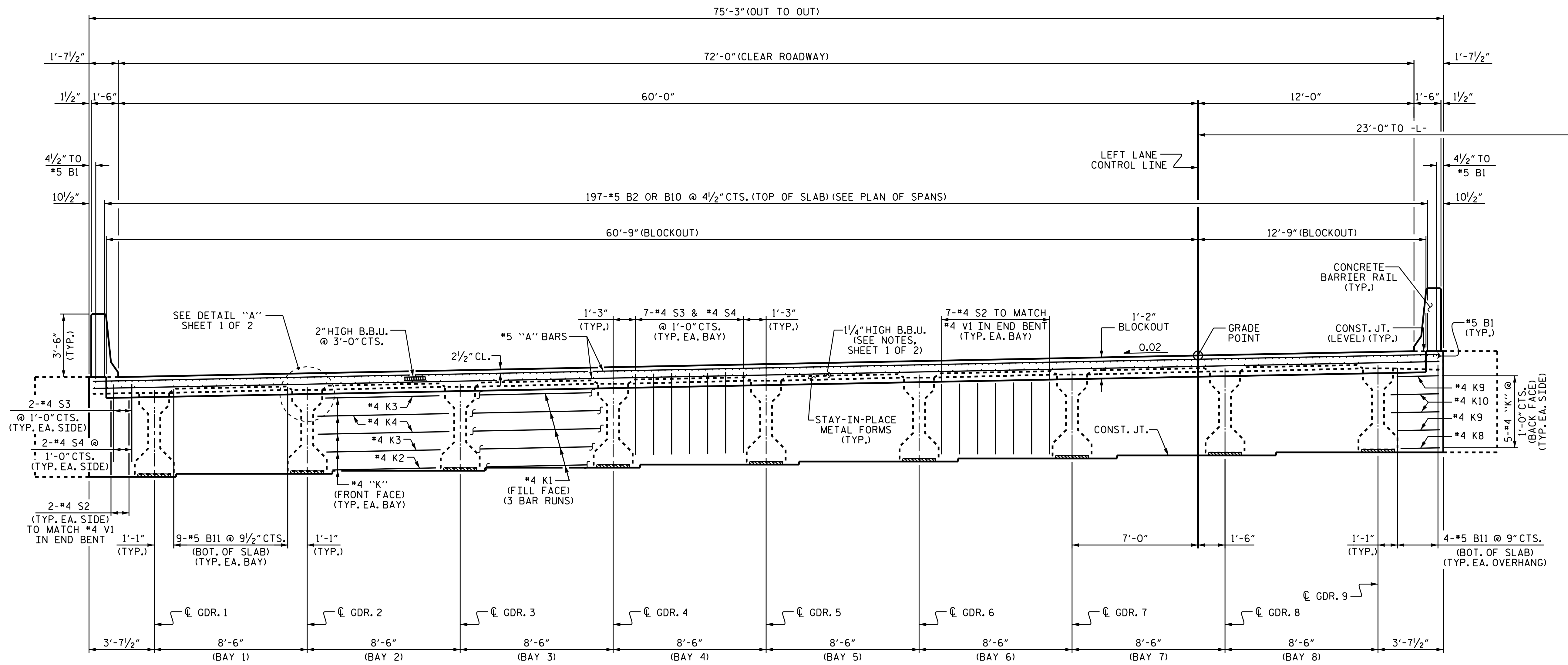

TYPICAL SECTION AT INTEGRAL END BENT

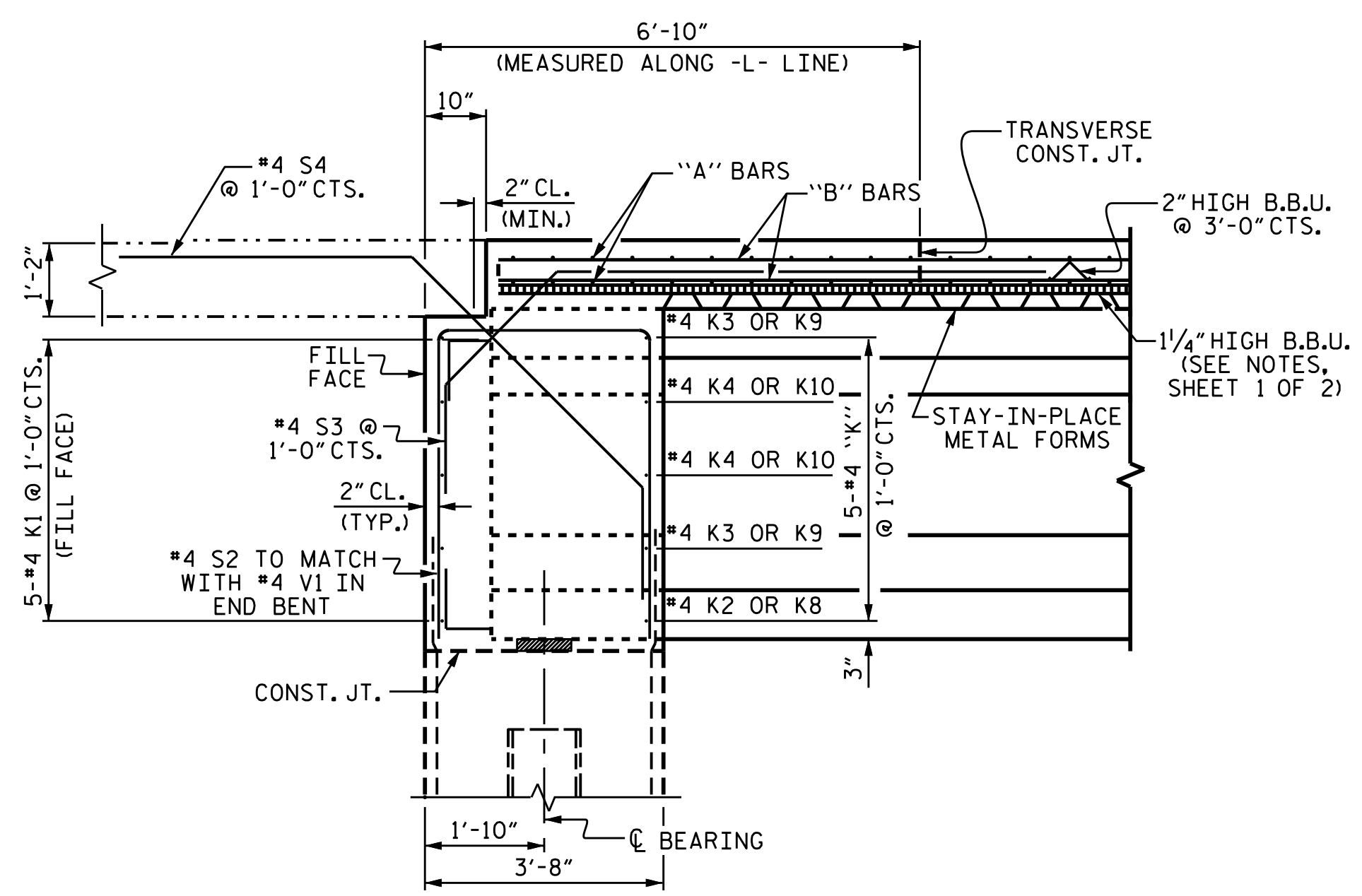

SECTION THROUGH INTEGRAL END BENT

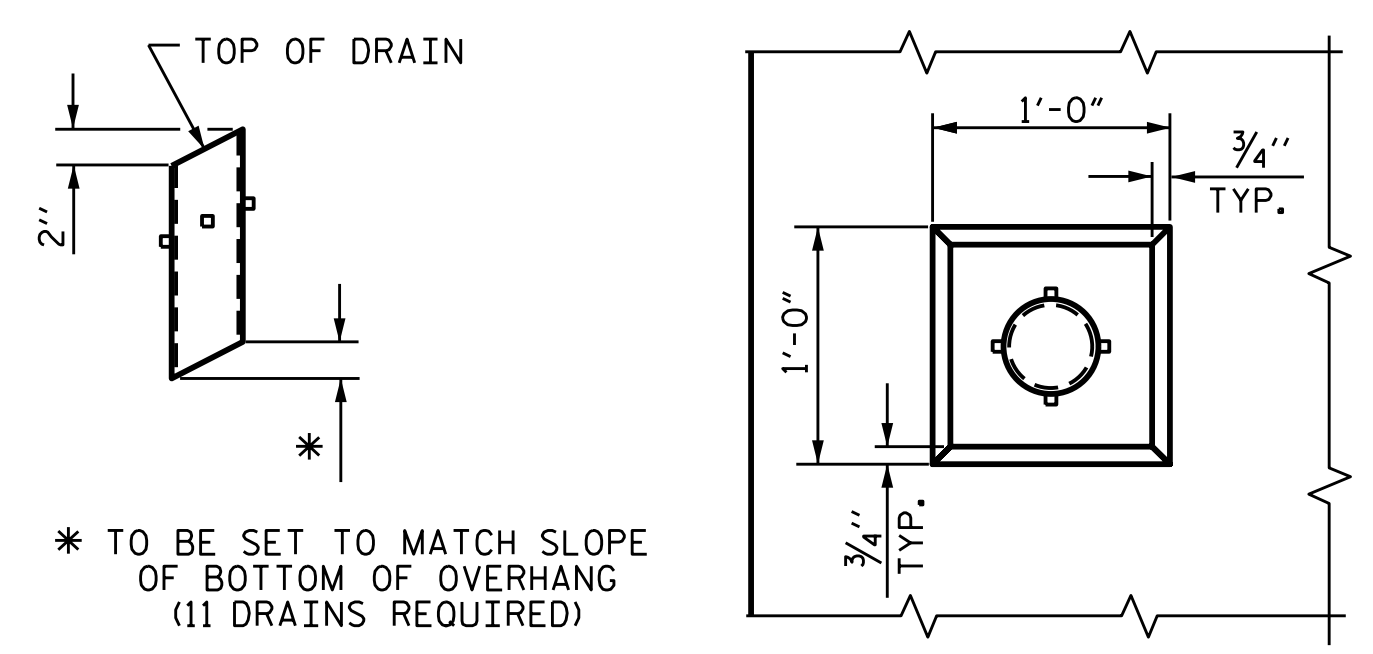

PIPE DETAIL PLAN OF RECESS

TOP OF FLOOR DRAINS TO BE SET 3/8" BELOW SURFACE OF SLAB.
 4 - 1/2" SQUARE LUGS TO BE GLUED TO THE P.V.C. PIPE AT EQUAL SPACES AROUND THE PIPE DRAIN APPROXIMATELY 4" FROM THE TOP OF THE PIPE.
 THE 6" Ø PVC PIPE AND FITTINGS SHALL BE SCHEDULE 40 AND CONFORM TO ASTM D1785.

DRAIN DETAILS

PROJECT NO. U-2579C
FORSYTH COUNTY
 STATION: 473+70.00 -L-

SHEET 2 OF 2



STATE OF NORTH CAROLINA
 DEPARTMENT OF TRANSPORTATION
 RALEIGH
 SUPERSTRUCTURE
 TYPICAL SECTION
 (LEFT LANE)

DRAWN BY: J. K. BOWLES DATE: 1/11/16
 CHECKED BY: N. D'AIUTO DATE: 3/17/16
 DESIGN ENGINEER OF RECORD: H. A. LOCKLEAR DATE: 3/17/16

DOCUMENT NOT CONSIDERED FINAL UNLESS ALL SIGNATURES COMPLETED

REVISIONS						SHEET NO.	
NO.	BY:	DATE:	NO.	BY:	DATE:	S3-6	
1			3			TOTAL SHEETS	33
2			4				

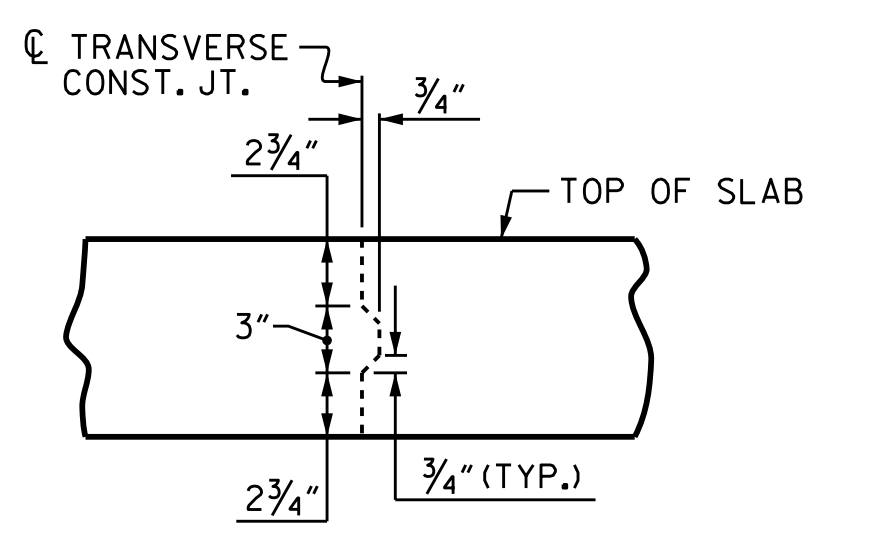
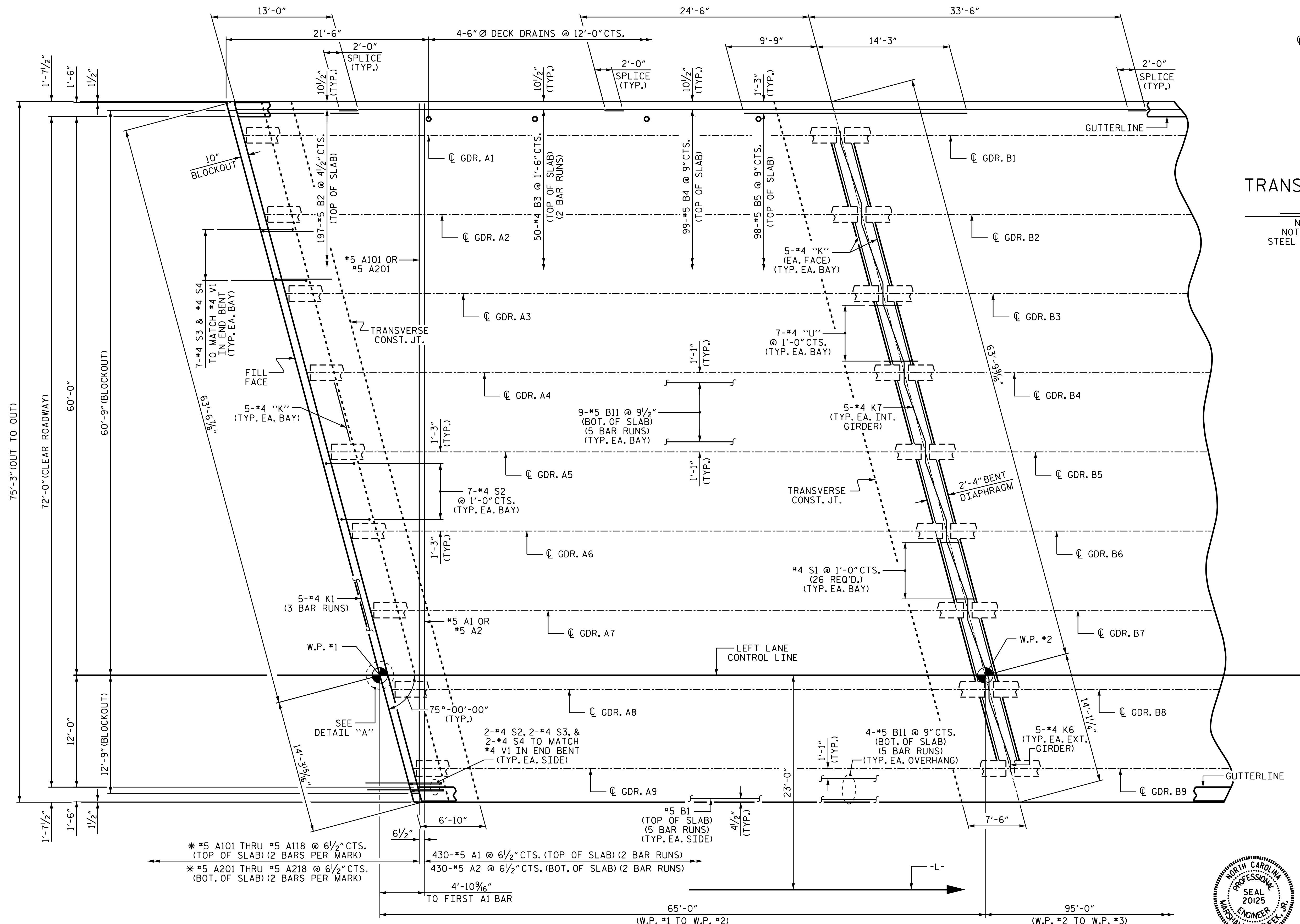

TRANSVERSE CONSTRUCTION JOINT DETAIL

NOTE: REINFORCING STEEL IN SLAB NOT SHOWN. LONGITUDINAL REINFORCING STEEL SHALL BE CONTINUOUS THROUGH JOINT.

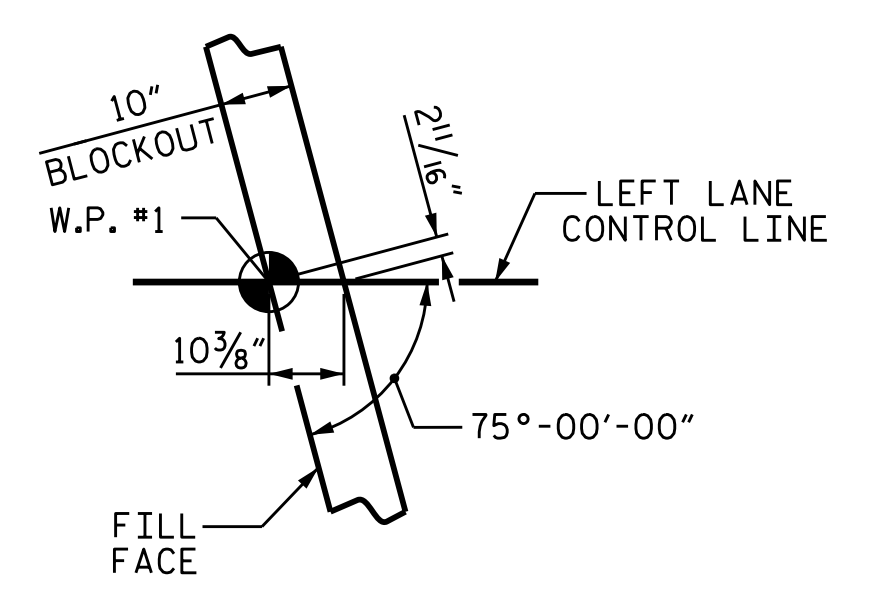

DETAIL "A"

PLAN OF SPAN A

INTERMEDIATE STEEL DIAPHRAGMS NOT SHOWN FOR CLARITY. FOR DETAILS, SEE "INTERMEDIATE STEEL DIAPHRAGMS FOR PRESTRESSED CONCRETE GIRDERS" SHEET.

* 2 BAR RUNS FOR A101 THROUGH A103 & A201 THROUGH A203.

PROJECT NO. U-2579C
 FORSYTH COUNTY
 STATION: 473+70.00 -L-

SHEET 1 OF 3

STATE OF NORTH CAROLINA
 DEPARTMENT OF TRANSPORTATION
 RALEIGH
 SUPERSTRUCTURE
 PLAN OF SPAN A
 (LEFT LANE)

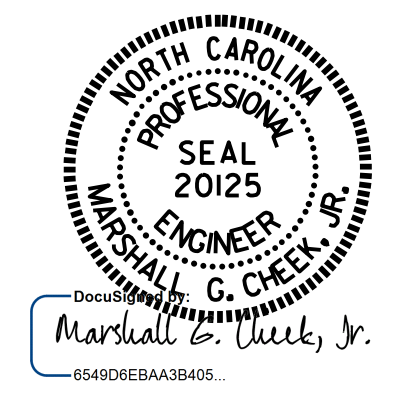

7/27/2017

REVISIONS						SHEET NO.	
NO.	BY:	DATE:	NO.	BY:	DATE:	S3-7	
1			3			TOTAL SHEETS	
2			4			33	

DOCUMENT NOT CONSIDERED FINAL UNLESS ALL SIGNATURES COMPLETED

DRAWN BY: J. K. BOWLES DATE: 1/20/16
 CHECKED BY: N. D'AIUTO DATE: 3/17/16
 DESIGN ENGINEER OF RECORD: H. A. LOCKLEAR DATE: 3/17/16

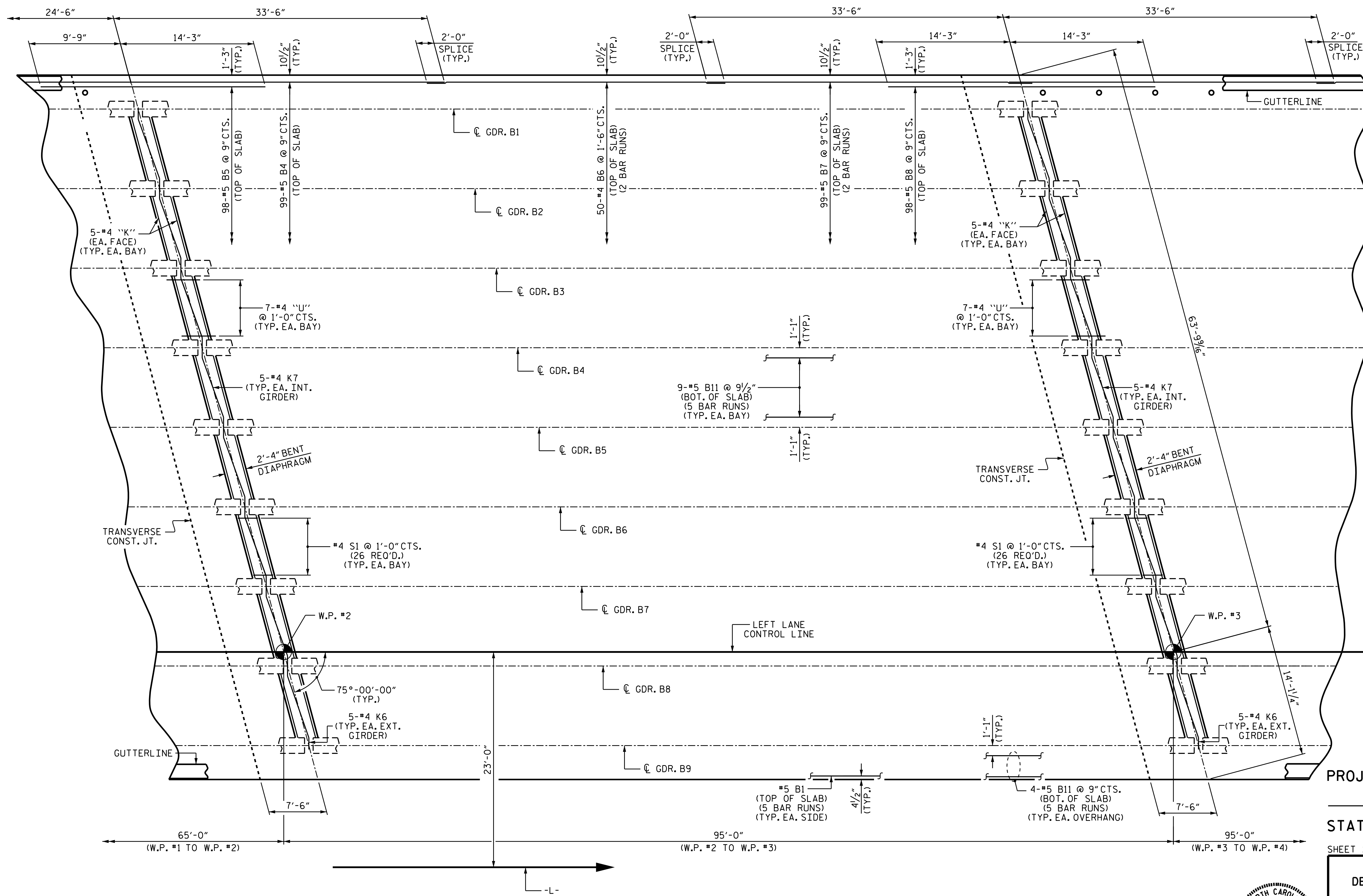

PROJECT NO. U-2579C
 FORSYTH COUNTY
 STATION: 473+70.00 -L-

SHEET 2 OF 3

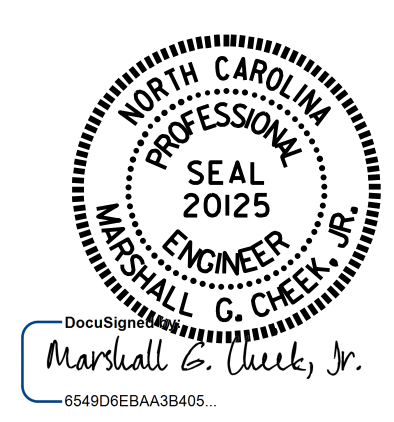

STATE OF NORTH CAROLINA
 DEPARTMENT OF TRANSPORTATION
 RALEIGH
 SUPERSTRUCTURE
 PLAN OF SPAN B
 (LEFT LANE)

PLAN OF SPAN B

INTERMEDIATE STEEL DIAPHRAGMS NOT SHOWN FOR CLARITY, FOR DETAILS, SEE "INTERMEDIATE STEEL DIAPHRAGMS FOR PRESTRESSED CONCRETE GIRDERS" SHEET.

DRAWN BY : J. K. BOWLES DATE : 1/20/16
 CHECKED BY : N. D'AIUTO DATE : 3/17/16
 DESIGN ENGINEER OF RECORD: H. A. LOCKLEAR DATE : 3/17/16

DOCUMENT NOT CONSIDERED FINAL UNLESS ALL SIGNATURES COMPLETED

REVISIONS						SHEET NO.	
NO.	BY:	DATE:	NO.	BY:	DATE:	S3-8	
1			3			TOTAL SHEETS 33	
2			4				

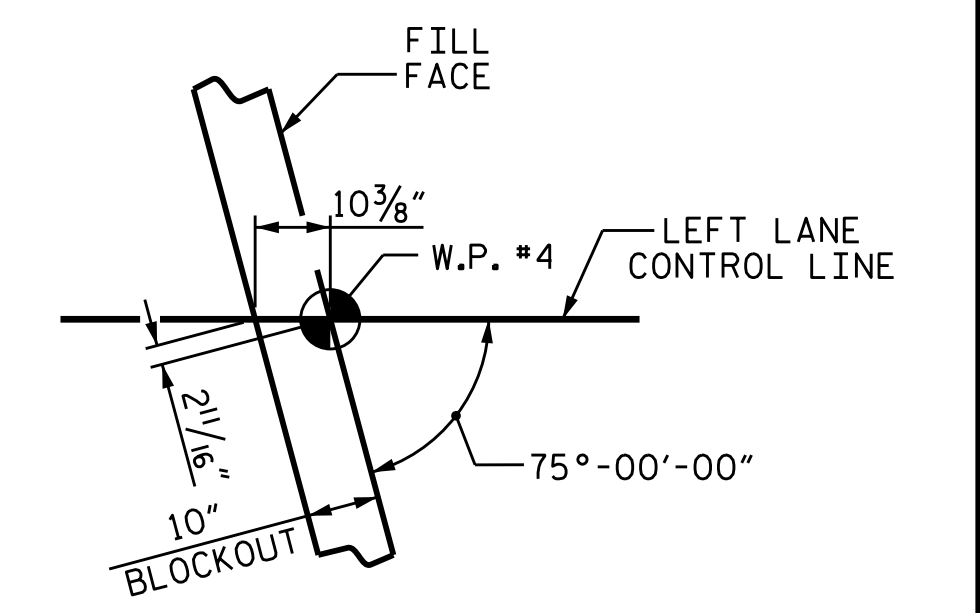
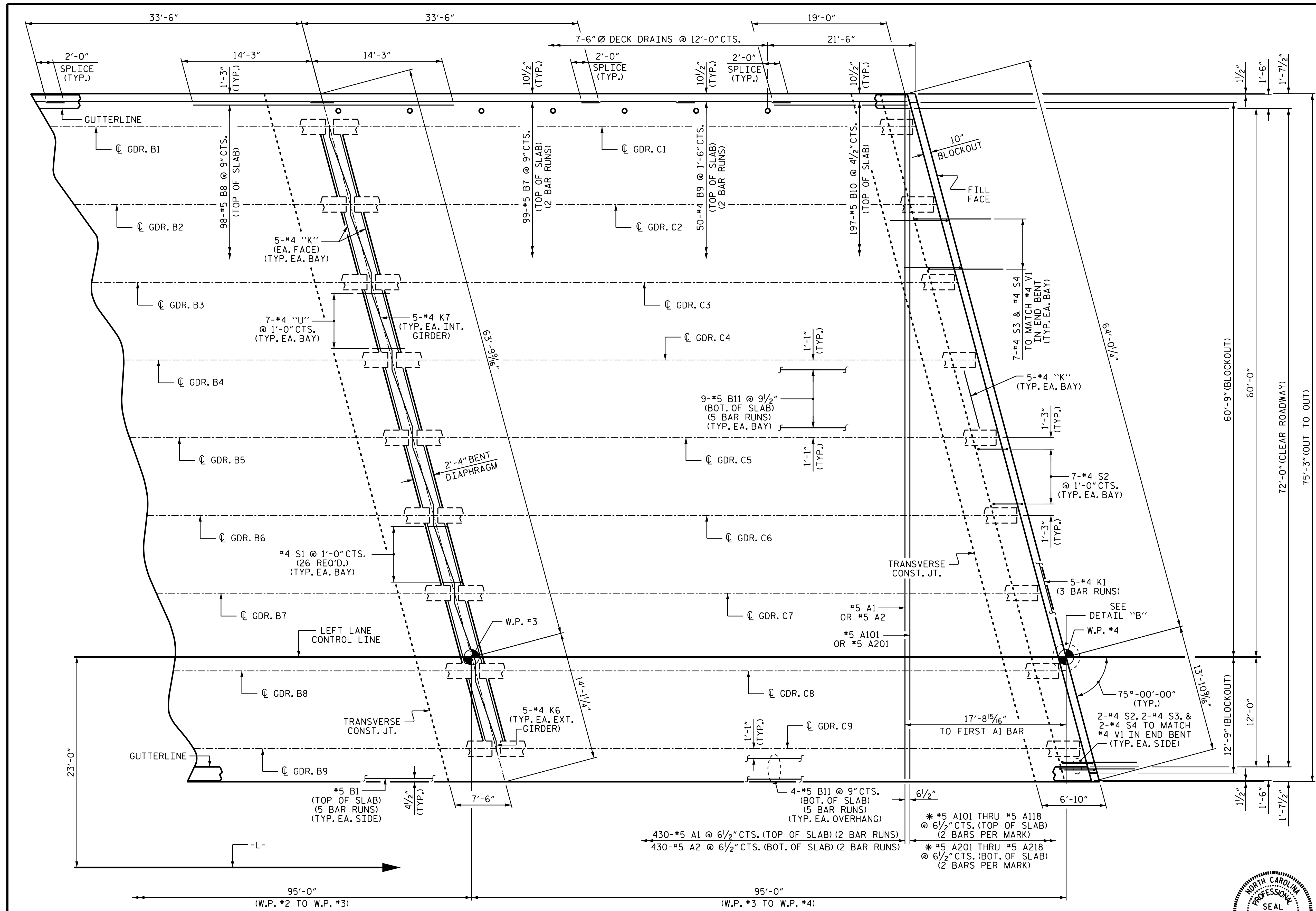

DETAIL "B"

PLAN OF SPAN C

INTERMEDIATE STEEL DIAPHRAGMS NOT SHOWN FOR CLARITY. FOR DETAILS, SEE "INTERMEDIATE STEEL DIAPHRAGMS FOR PRESTRESSED CONCRETE GIRDERS" SHEET.

* 2 BAR RUNS FOR A101 THROUGH A103 & A201 THROUGH A203.

PROJECT NO. U-2579C
 FORSYTH COUNTY
 STATION: 473+70.00 -L-

SHEET 3 OF 3

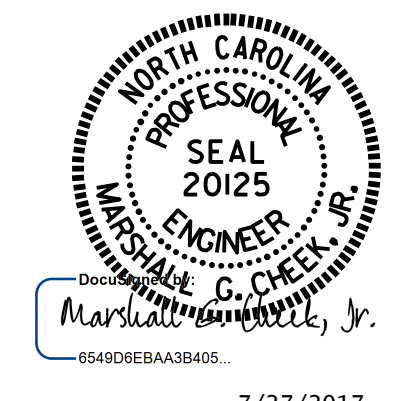

STATE OF NORTH CAROLINA
 DEPARTMENT OF TRANSPORTATION
 RALEIGH

SUPERSTRUCTURE
 PLAN OF SPAN C
 (LEFT LANE)

REVISIONS						SHEET NO.
NO.	BY:	DATE:	NO.	BY:	DATE:	S3-9
1			3			TOTAL SHEETS
2			4			33

DRAWN BY: J. K. BOWLES DATE: 1/20/16
 CHECKED BY: N. D'AIUTO DATE: 3/17/16
 DESIGN ENGINEER OF RECORD: H. A. LOCKLEAR DATE: 3/17/16

DOCUMENT NOT CONSIDERED FINAL UNLESS ALL SIGNATURES COMPLETED

STR. #3

INTEGRAL
E1

FIXED
E2,P2

FIXED
E2,P1

FIXED
E2,P3

FIXED
E2,P1

INTEGRAL
E1

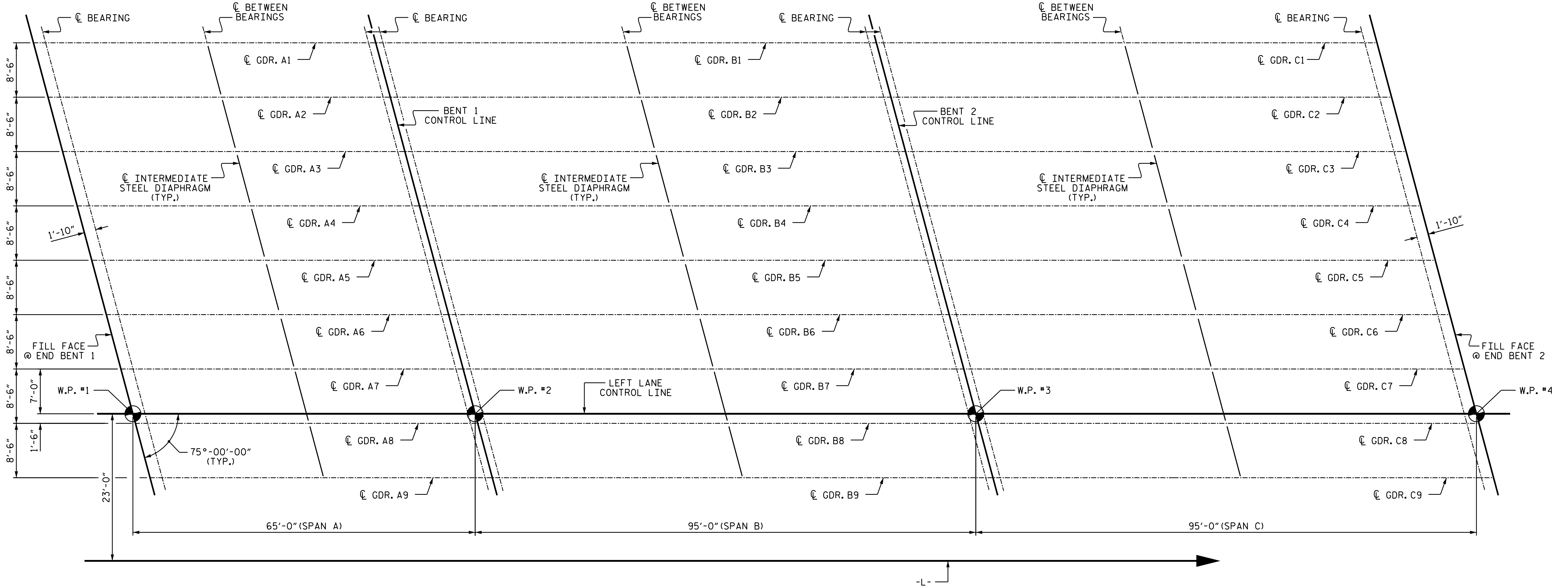

FRAMING PLAN

PROJECT NO. U-2579C
FORSYTH COUNTY
STATION: 473+70.00 -L-

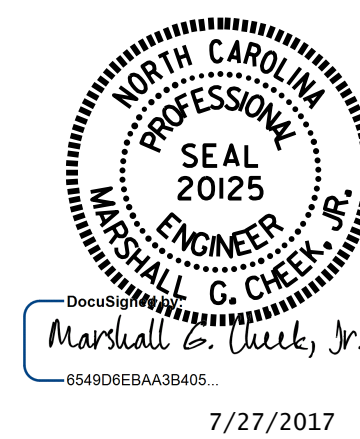

STATE OF NORTH CAROLINA
DEPARTMENT OF TRANSPORTATION
RALEIGH
SUPERSTRUCTURE
FRAMING PLAN
(LEFT LANE)

DRAWN BY : J. K. BOWLES DATE : 1/29/16
CHECKED BY : N. D'AIUTO DATE : 3/17/16
DESIGN ENGINEER OF RECORD: H. A. LOCKLEAR DATE : 3/17/16

DOCUMENT NOT CONSIDERED
FINAL UNLESS ALL
SIGNATURES COMPLETED

REVISIONS						SHEET NO.	
NO.	BY:	DATE:	NO.	BY:	DATE:	S3-10	
1			3			TOTAL SHEETS	
2			4			33	

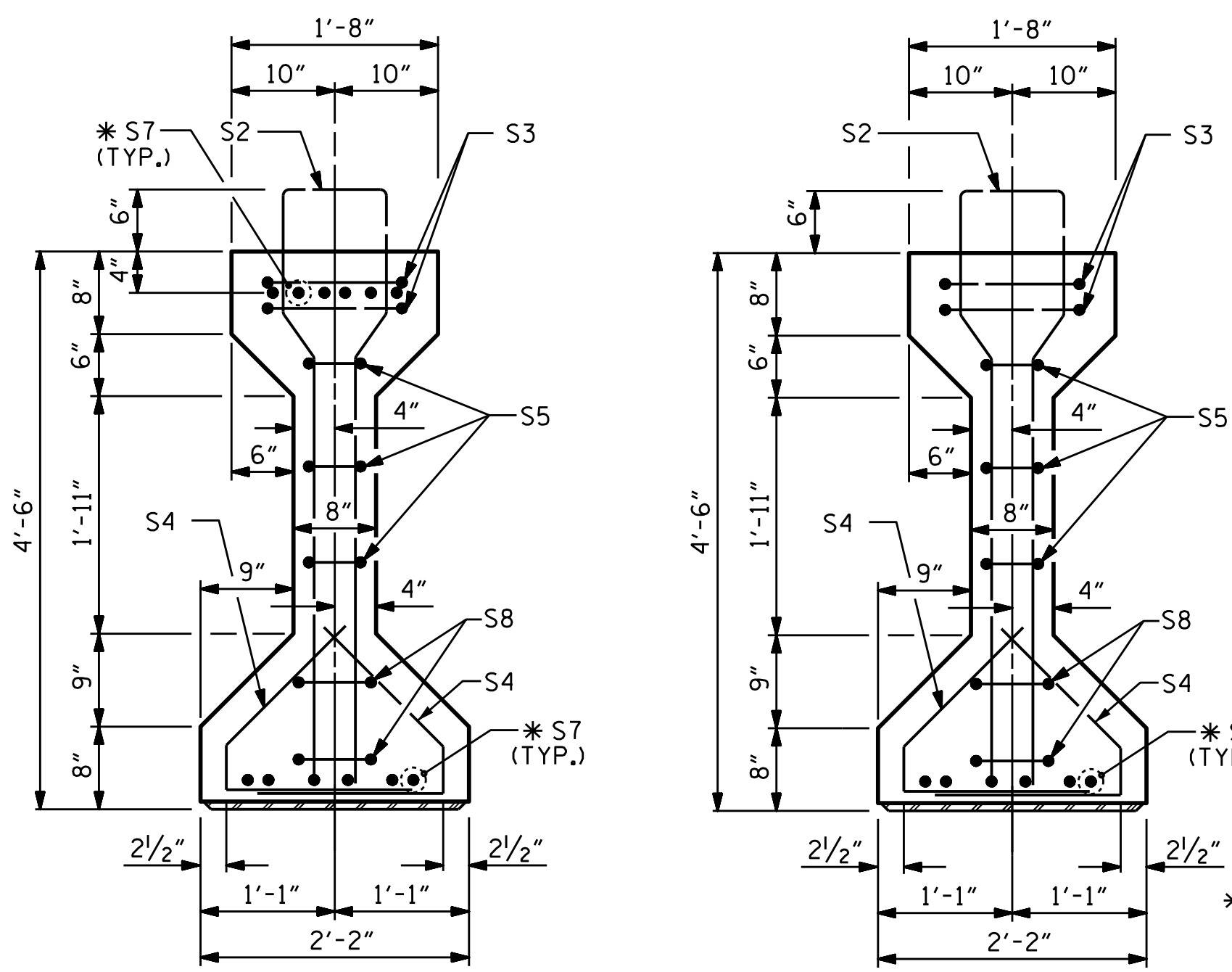

SECTION A-A

SECTION B-B

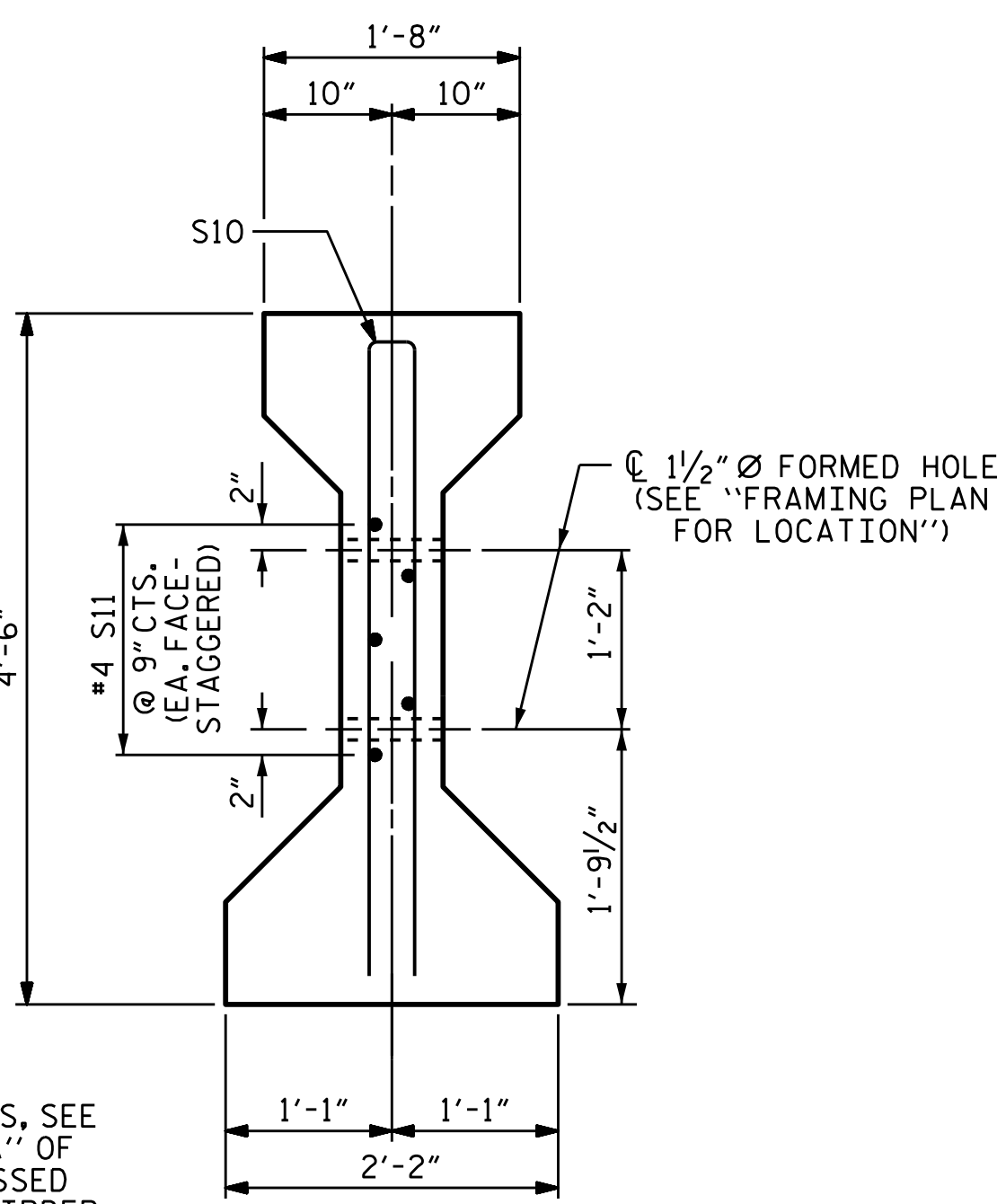

SECTION C-C
(S1 BARS NOT SHOWN)

* FOR S7 BARS, SEE
DETAIL "A" OF
"PRESTRESSED
CONCRETE GIRDER
CONTINUOUS FOR LIVE
LOAD DETAILS" SHEET

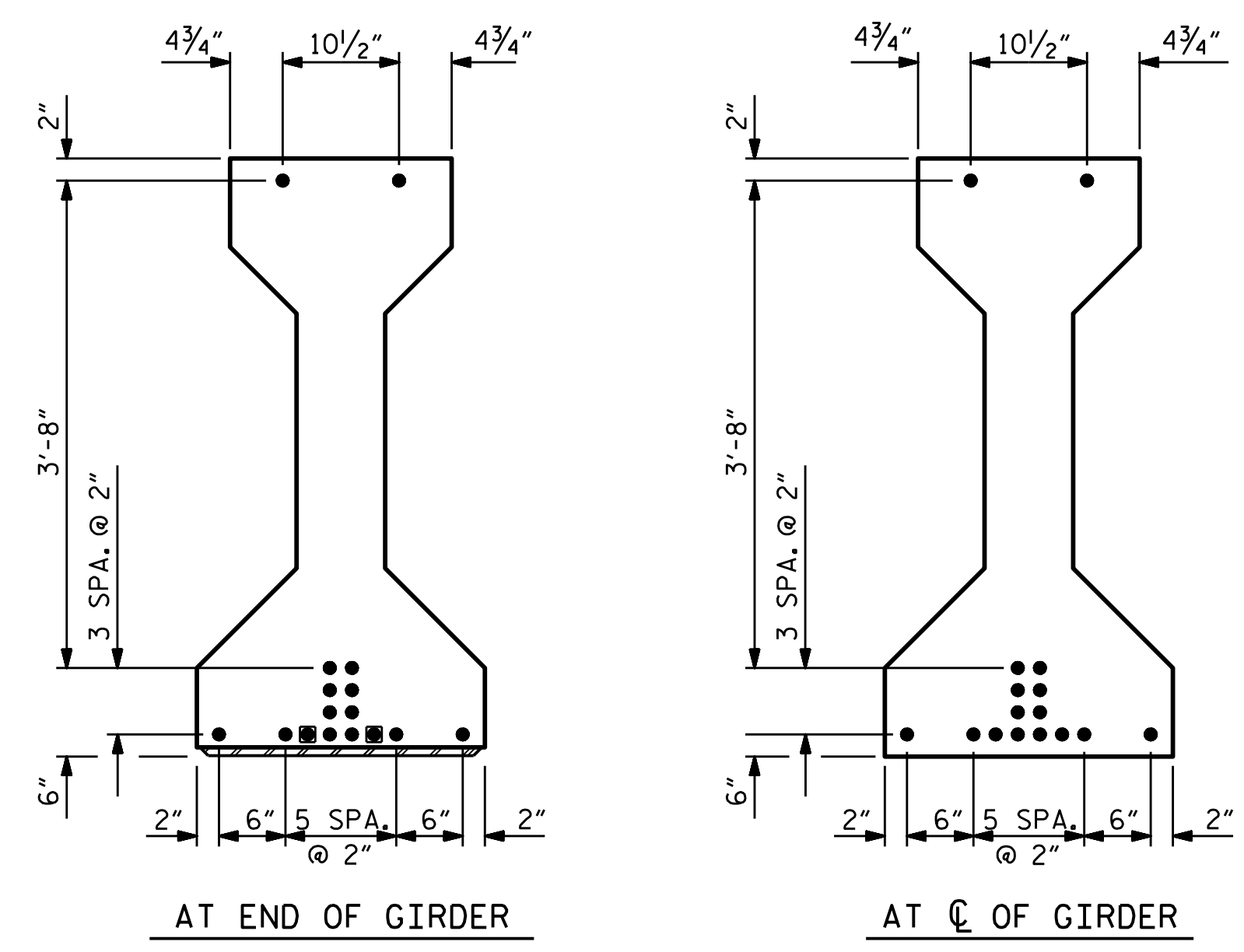

0.6" Ø LOW RELAXATION STRAND LAYOUT

- FULLY BONDED STRANDS
- STRANDS DEBONDED FOR 12'-0" FROM END OF GIRDER

0.6" Ø L. R. GRADE 270 STRANDS

AREA (SQUARE INCHES)	ULTIMATE STRENGTH (LBS. PER STRAND)	APPLIED PRESTRESS (LBS. PER STRAND)
0.217	58,600	43,950

REINFORCING STEEL FOR ONE GIRDER

BAR	NUMBER	SIZE	TYPE	LENGTH	WEIGHT
S1	80	#4	1	10'-8"	570
S2	12	#6	1	10'-8"	192
S3	4	#4	2	9'-1"	24
S4	72	#4	3	3'-5"	164
S5	6	#4	2	8'-5"	34
* S7	18	#5	STR	3'-7"	69
S8	4	#4	2	8'-7"	23
S9	2	#3	STR	1'-10"	1
S10	2	#5	2	8'-8"	18
S11	5	#4	STR	7'-0"	23
S13	1	#3	STR	1'-4"	1

* NOTE: S7 BARS SHALL BE BENT BEFORE SHIPMENT. HEAT BENDING SHALL NOT BE ALLOWED.

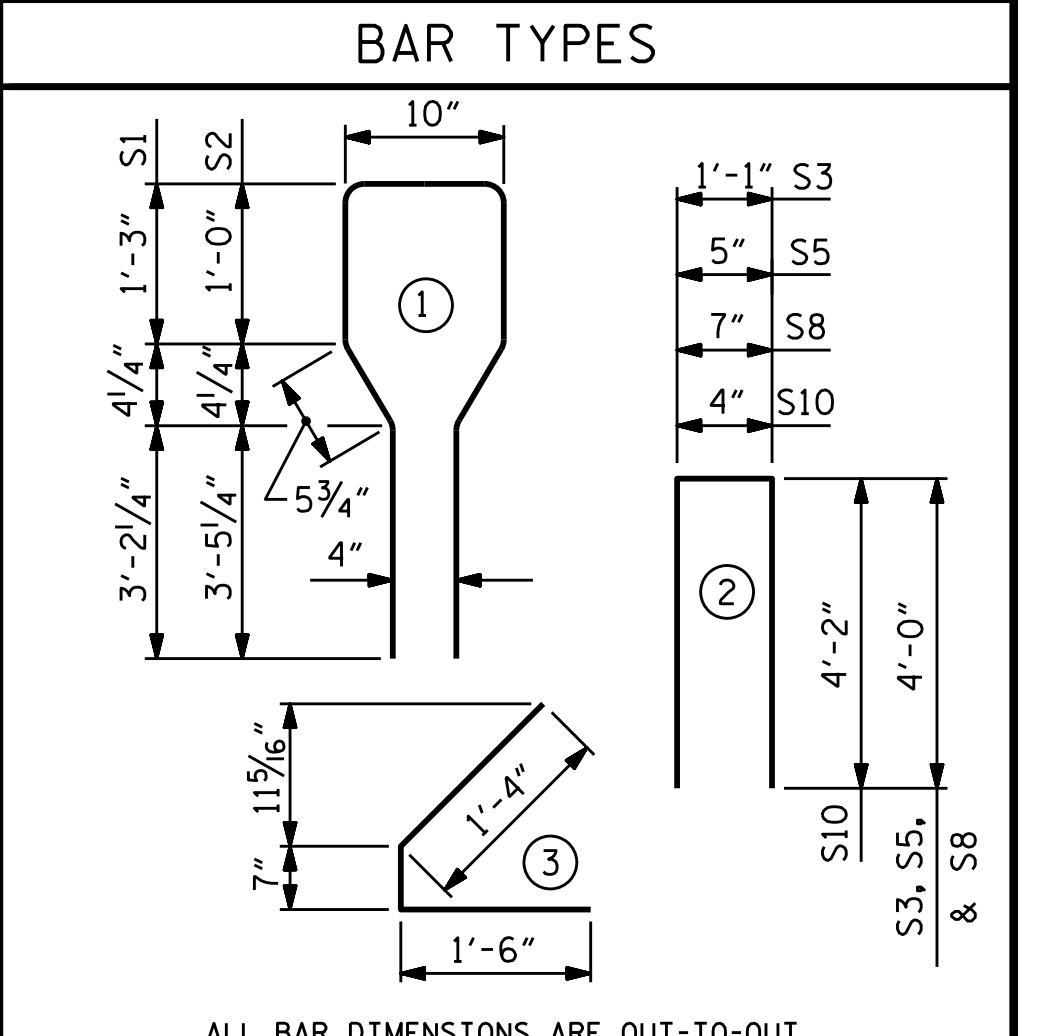

ALL BAR DIMENSIONS ARE OUT-TO-OUT.

QUANTITIES FOR ONE GIRDER

REINFORCING STEEL	5,000 PSI CONCRETE	0.6" Ø L. R. STRANDS
LBS.	C.Y.	No.
1,119	12.9	16

GIRDERS REQUIRED

NUMBER	LENGTH	TOTAL LENGTH
9	63'-4 3/4"	570'-6 3/4"

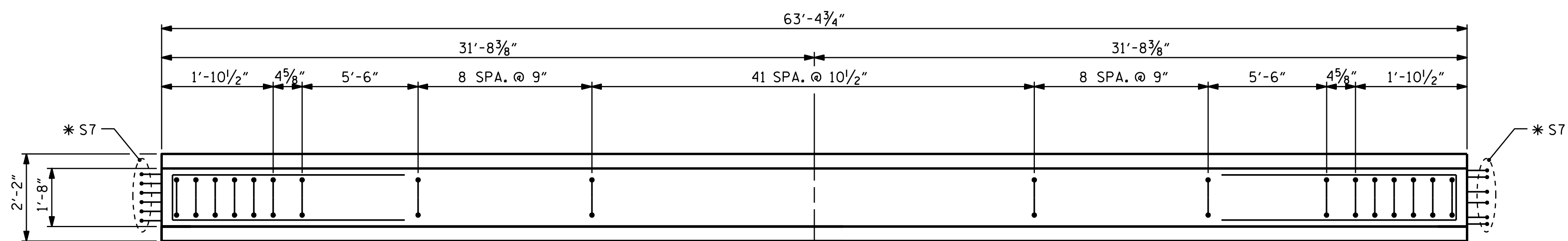

PLAN OF GIRDER

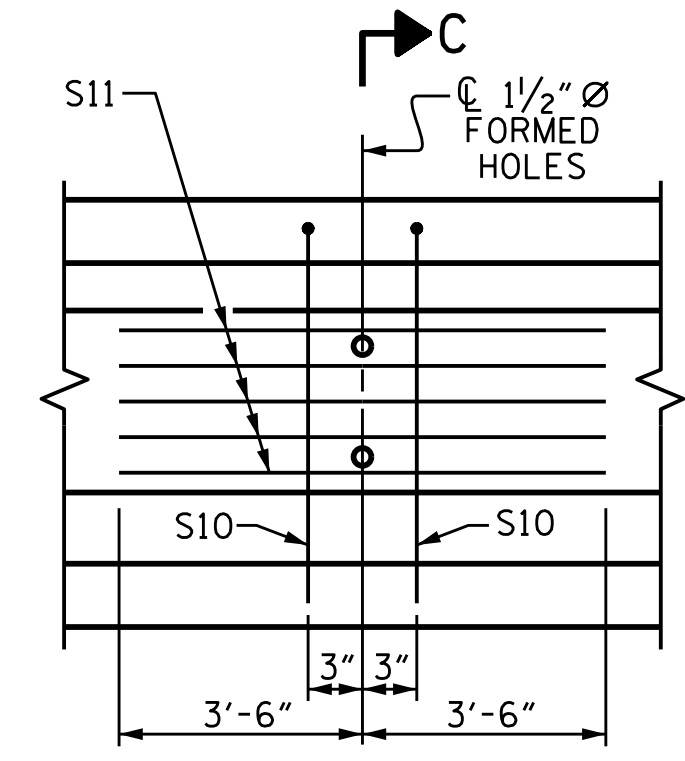

PARTIAL ELEVATION

SHOWING INTERMEDIATE DIAPHRAGM REINFORCING STEEL FOR SPAN A GIRDERS.

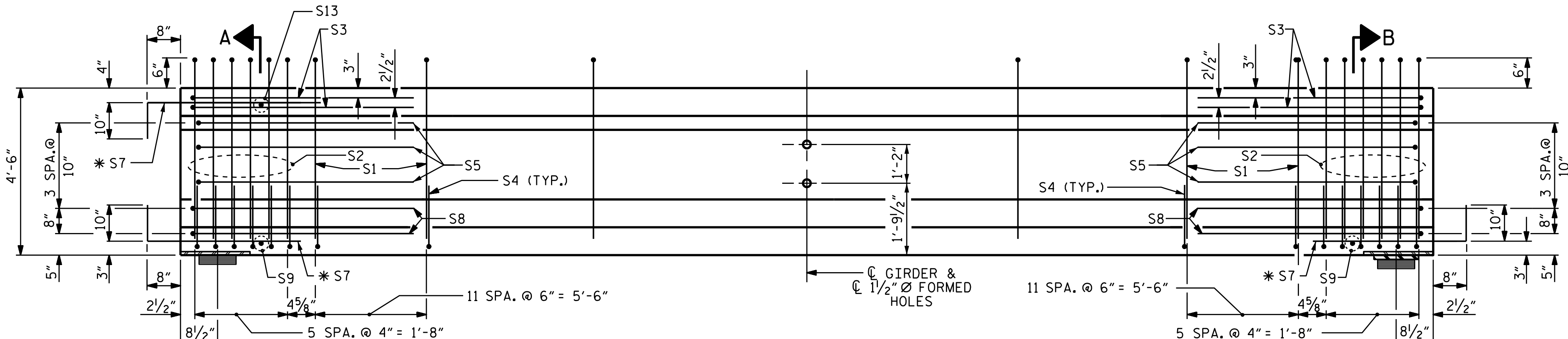

ELEVATION OF GIRDER

(SEE PARTIAL ELEVATION FOR ADDITIONAL "S" BARS)

ASSEMBLED BY : H. A. LOCKLEAR	DATE : 12-15
CHECKED BY : N. D'AIUTO	DATE : 3/17/16
DRAWN BY : ELR 8/91	REV. 5/1/06R TLA/GM
CHECKED BY : GRP 8/91	REV. 10/1/11 MAA/GM
	REV. 1/15 MAA/TMG

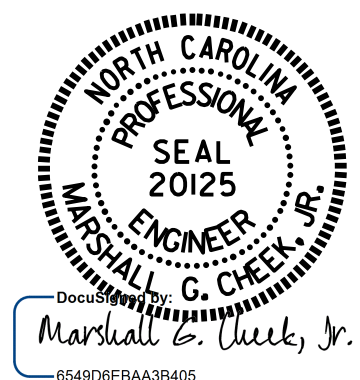

8/1/2017

DOCUMENT NOT CONSIDERED FINAL UNLESS ALL SIGNATURES COMPLETED

REVISIONS						SHEET NO.
NO.	BY:	DATE:	NO.	BY:	DATE:	S3-11
1			3			TOTAL SHEETS 33
2			4			

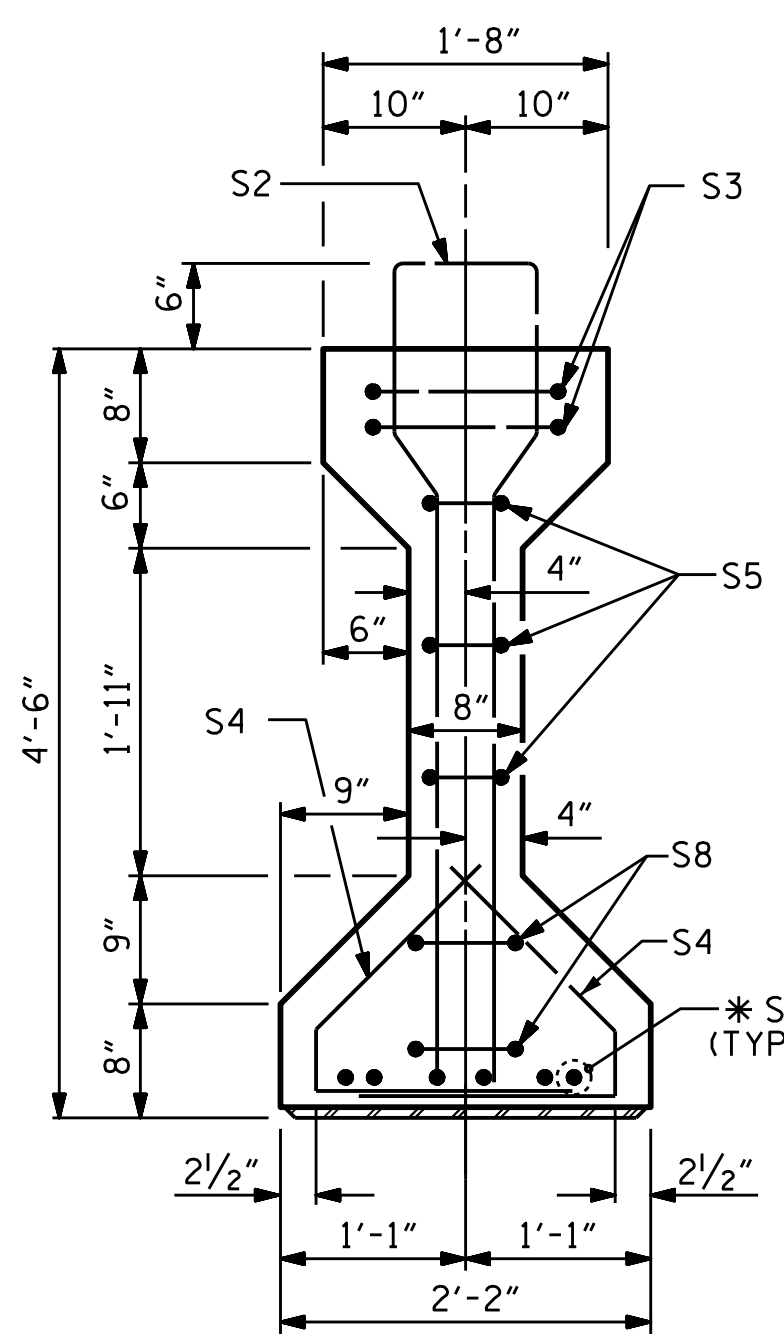

SECTION B-B

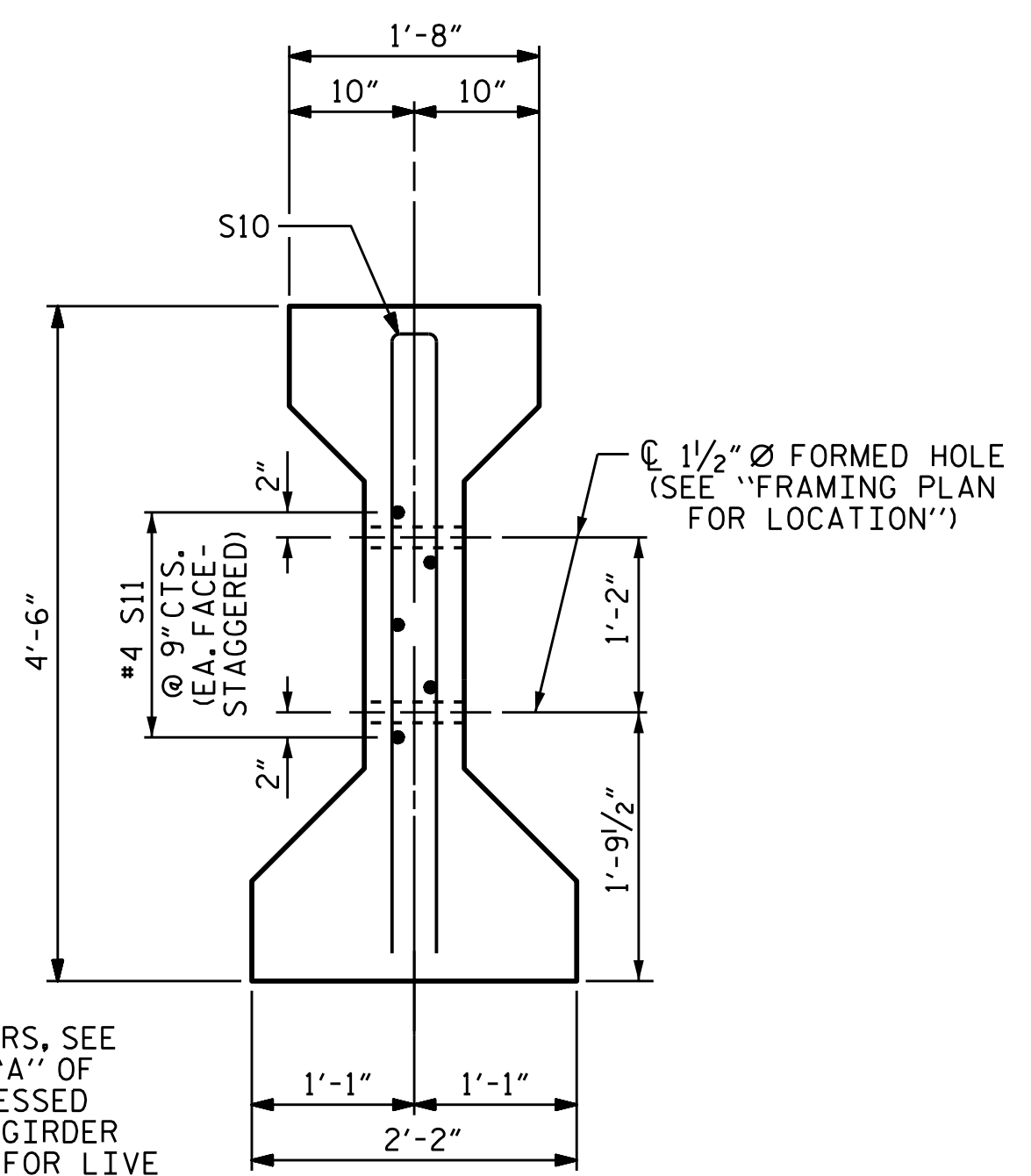

SECTION C-C
(S1 BARS NOT SHOWN)

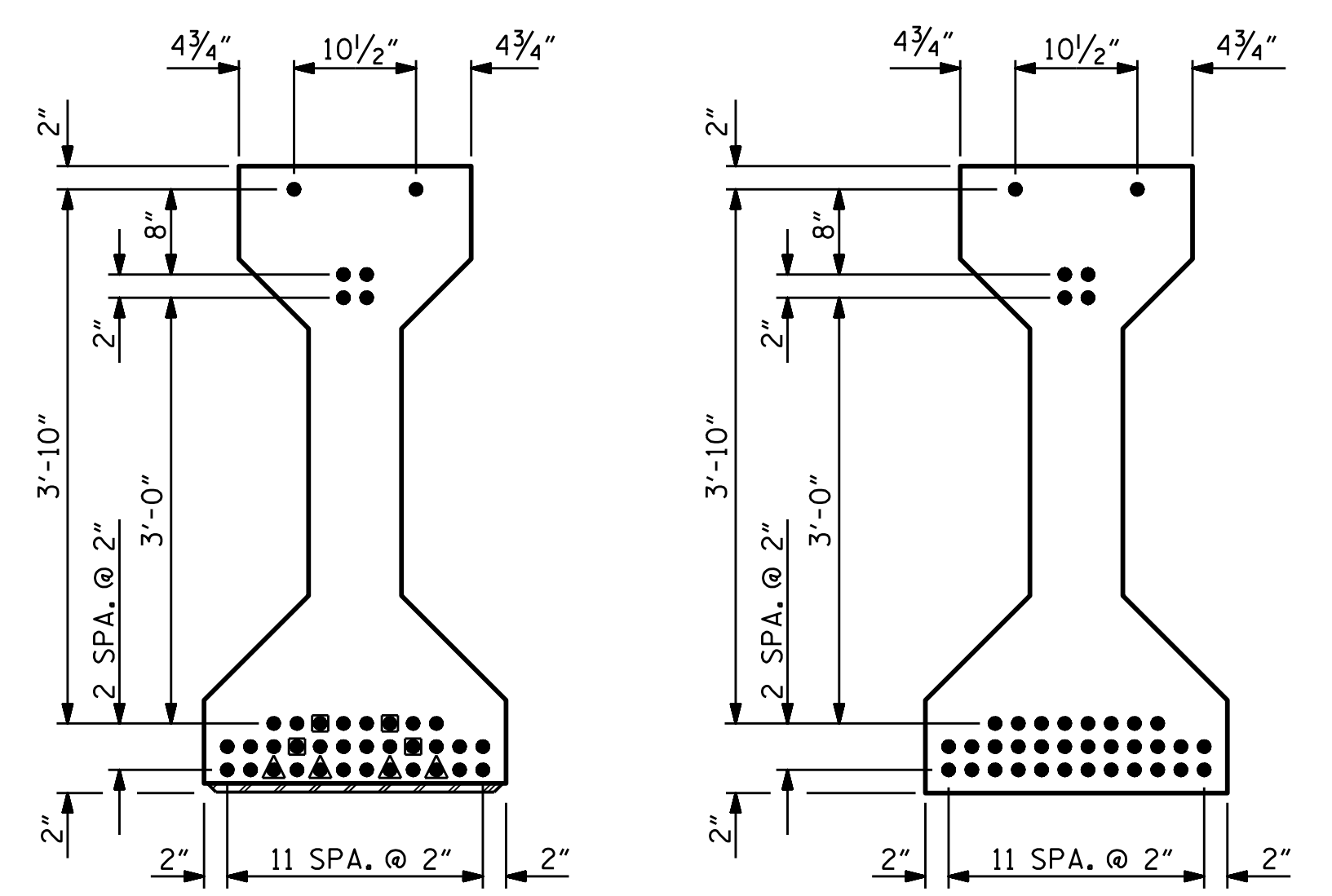

0.6" Ø LOW RELAXATION STRAND LAYOUT

- FULLY BONDED STRANDS
- STRANDS DEBONDED FOR 12'-0" FROM END OF GIRDER
- ▲ STRANDS DEBONDED FOR 10'-0" FROM END OF GIRDER

0.6" Ø L. R. GRADE 270 STRANDS		
AREA (SQUARE INCHES)	ULTIMATE STRENGTH (LBS. PER STRAND)	APPLIED PRESTRESS (LBS. PER STRAND)
0.217	58,600	43,950

REINFORCING STEEL FOR ONE GIRDER					
BAR	NUMBER	SIZE	TYPE	LENGTH	WEIGHT
S1	130	#4	1	10'-8"	926
S2	12	#6	1	10'-8"	192
S3	4	#4	2	9'-1"	24
S4	172	#4	3	3'-5"	393
S5	6	#4	2	8'-5"	34
* S7	12	#5	STR	3'-8"	46
S8	4	#4	2	8'-7"	23
S9	2	#3	STR	1'-10"	1
S10	2	#5	2	8'-8"	18
S11	5	#4	STR	7'-0"	23

* NOTE: S7 BARS SHALL BE BENT BEFORE SHIPMENT. HEAT BENDING SHALL NOT BE ALLOWED.

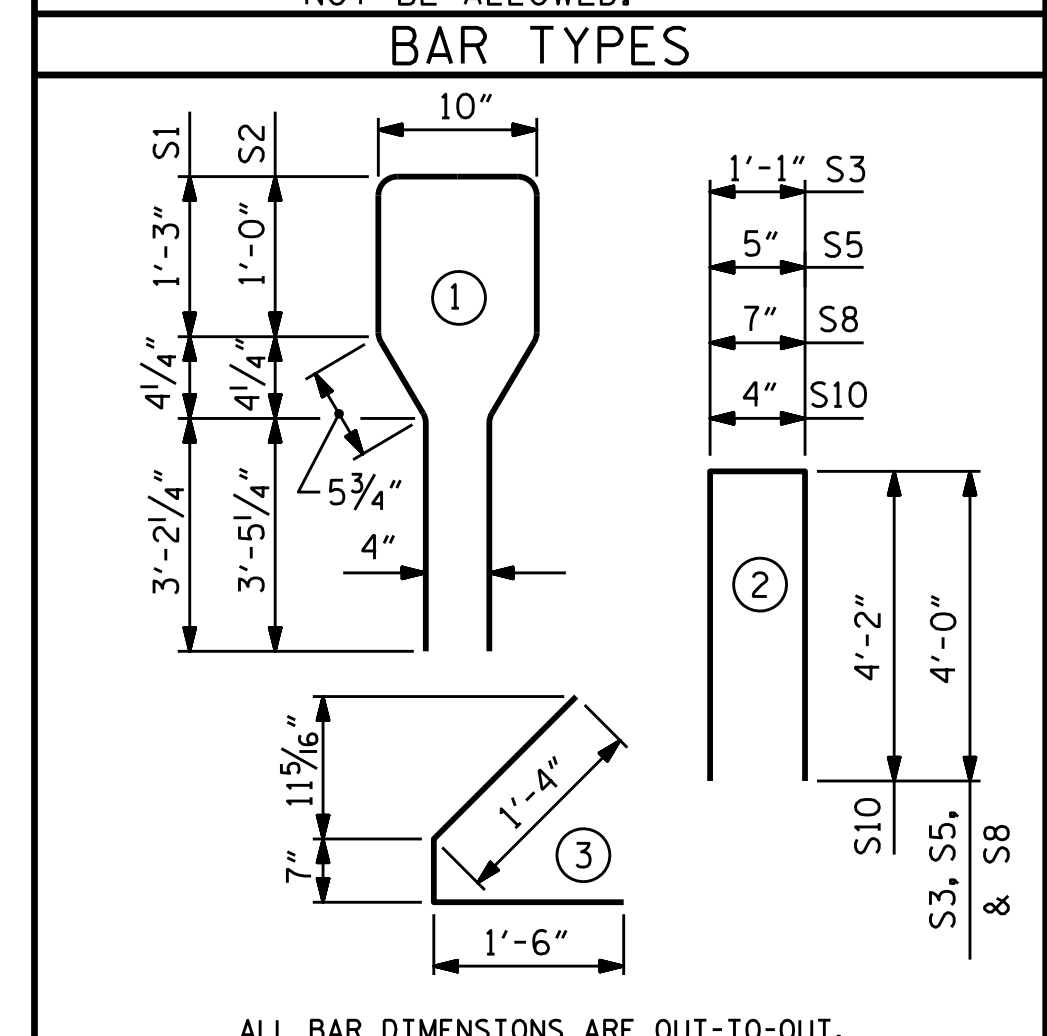

ALL BAR DIMENSIONS ARE OUT-TO-OUT.

QUANTITIES FOR ONE GIRDER		
REINFORCING STEEL	7,500 PSI CONCRETE	0.6" Ø L. R. STRANDS
LBS.	C.Y.	No.
1,680	19.1	38

GIRDERS REQUIRED		
NUMBER	LENGTH	TOTAL LENGTH
9	94'-2"	847'-6"

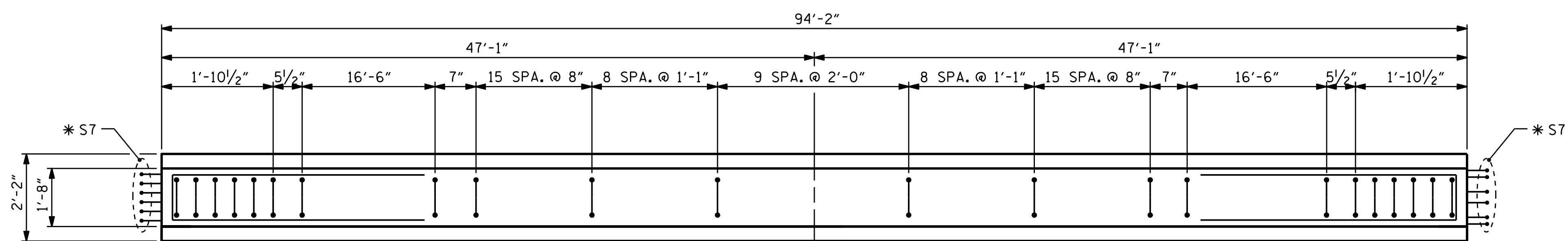

PLAN OF GIRDER

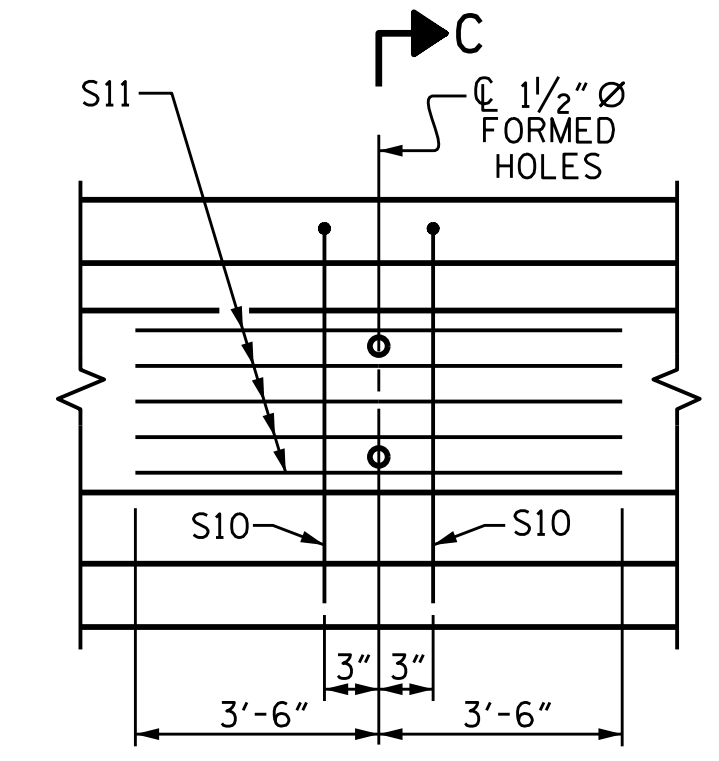

PARTIAL ELEVATION

SHOWING INTERMEDIATE DIAPHRAGM REINFORCING STEEL FOR SPAN B GIRDERS.

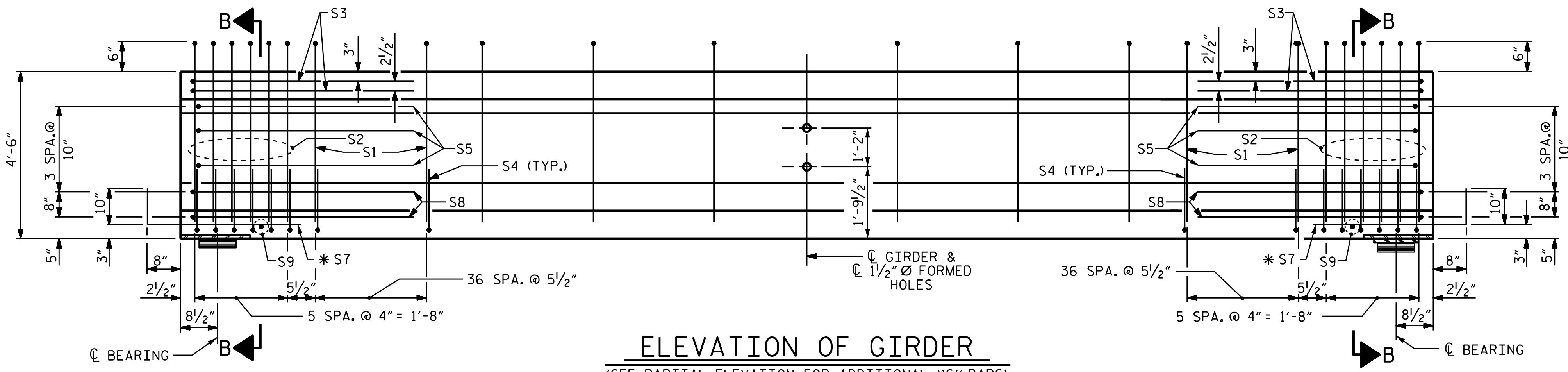

ELEVATION OF GIRDER

(SEE PARTIAL ELEVATION FOR ADDITIONAL "S" BARS)



7/27/2017

ASSEMBLED BY : H. A. LOCKLEAR	DATE : 12-15
CHECKED BY : N. D'AIUTO	DATE : 3/17/16
DRAWN BY : ELR 8/91	REV. 5/1/06R TLA/GM
CHECKED BY : GRP 8/91	REV. 10/1/11 MAA/GM
	REV. 1/15 MAA/TMG

DOCUMENT NOT CONSIDERED FINAL UNLESS ALL SIGNATURES COMPLETED

REVISIONS						SHEET NO.
NO.	BY:	DATE:	NO.	BY:	DATE:	S3-12
1			3			TOTAL SHEETS 33
2			4			

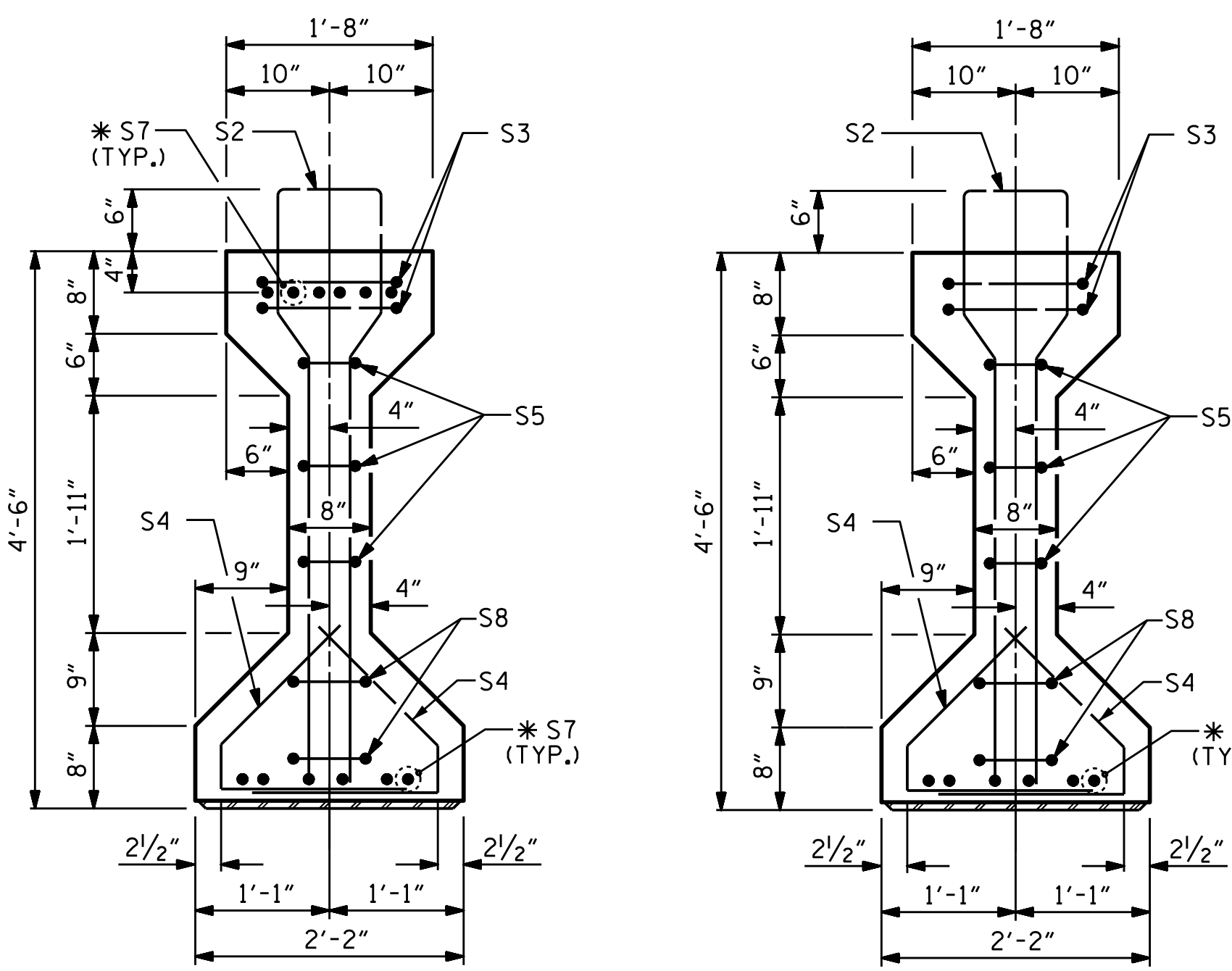

SECTION A-A

SECTION B-B

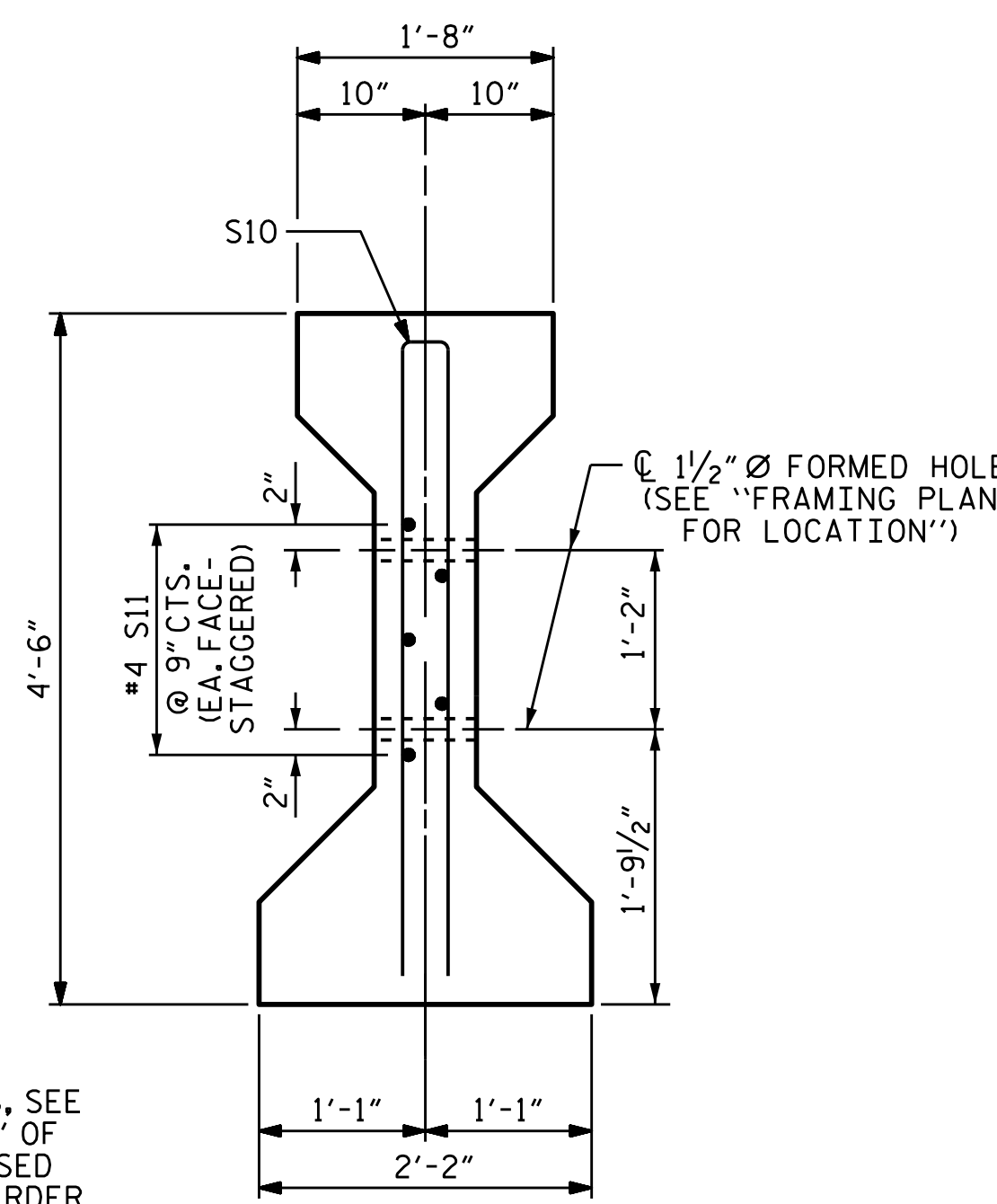

SECTION C-C
(S1 BARS NOT SHOWN)

* FOR S7 BARS, SEE
DETAIL "A" OF
"PRESTRESSED
CONCRETE GIRDER
CONTINUOUS FOR LIVE
LOAD DETAILS" SHEET

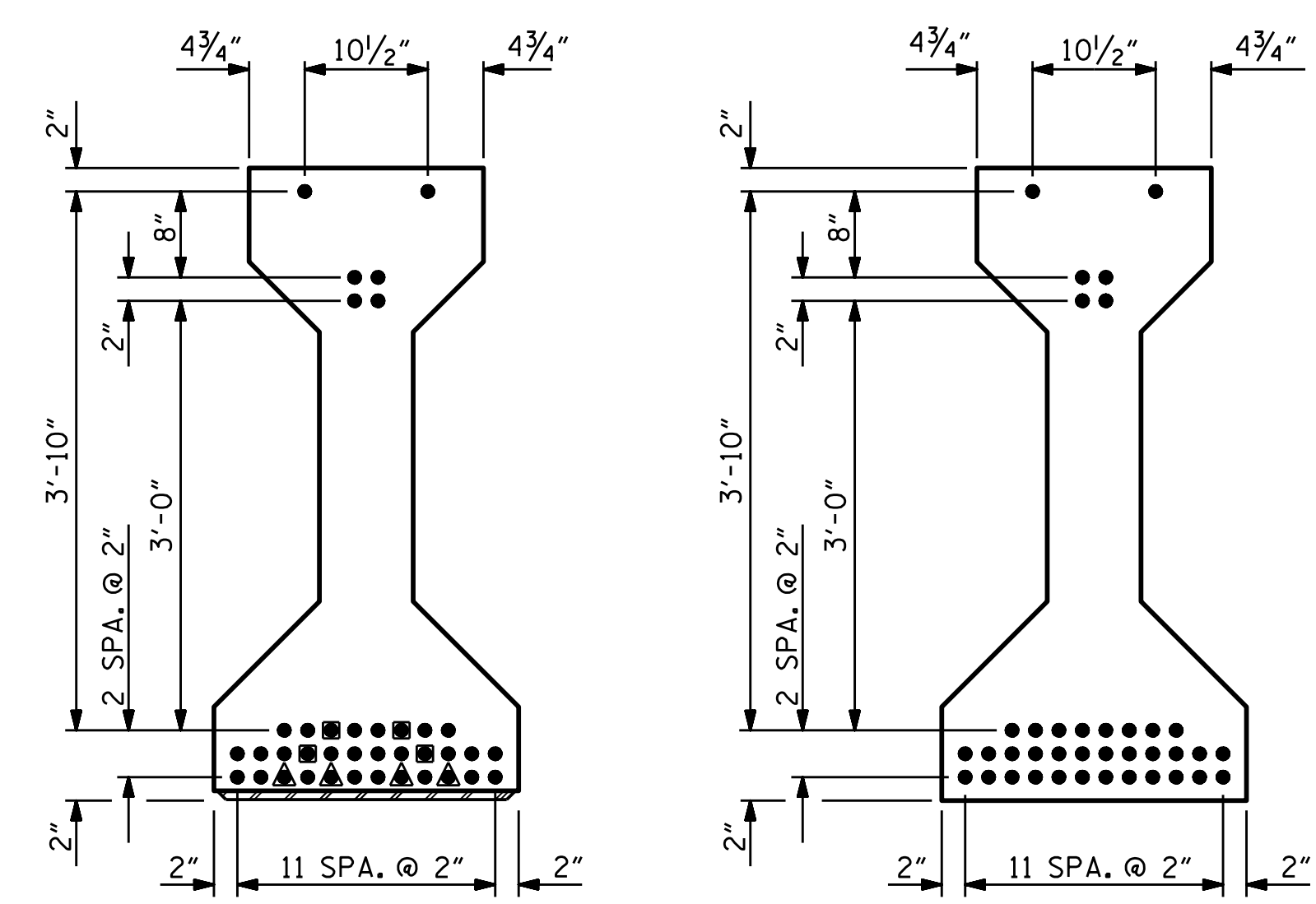

AT END OF GIRDER
AT \bar{C} OF GIRDER
0.6" Ø LOW RELAXATION STRAND LAYOUT

- FULLY BONDED STRANDS
- STRANDS DEBONDED FOR 12'-0" FROM END OF GIRDER
- ▲ STRANDS DEBONDED FOR 10'-0" FROM END OF GIRDER

0.6" Ø L. R. GRADE 270 STRANDS

AREA (SQUARE INCHES)	ULTIMATE STRENGTH (LBS. PER STRAND)	APPLIED PRESTRESS (LBS. PER STRAND)
0.217	58,600	43,950

REINFORCING STEEL FOR ONE GIRDER

BAR	NUMBER	SIZE	TYPE	LENGTH	WEIGHT
S1	130	#4	1	10'-8"	926
S2	12	#6	1	10'-8"	192
S3	4	#4	2	9'-1"	24
S4	180	#4	3	3'-5"	411
S5	6	#4	2	8'-5"	34
*S7	18	#5	STR	3'-8"	69
S8	4	#4	2	8'-7"	23
S9	2	#3	STR	1'-10"	1
S10	2	#5	2	8'-8"	18
S11	5	#4	STR	7'-0"	23
S13	1	#3	STR	1'-4"	1

* NOTE: S7 BARS SHALL BE BENT BEFORE SHIPMENT. HEAT BENDING SHALL NOT BE ALLOWED.

BAR TYPES

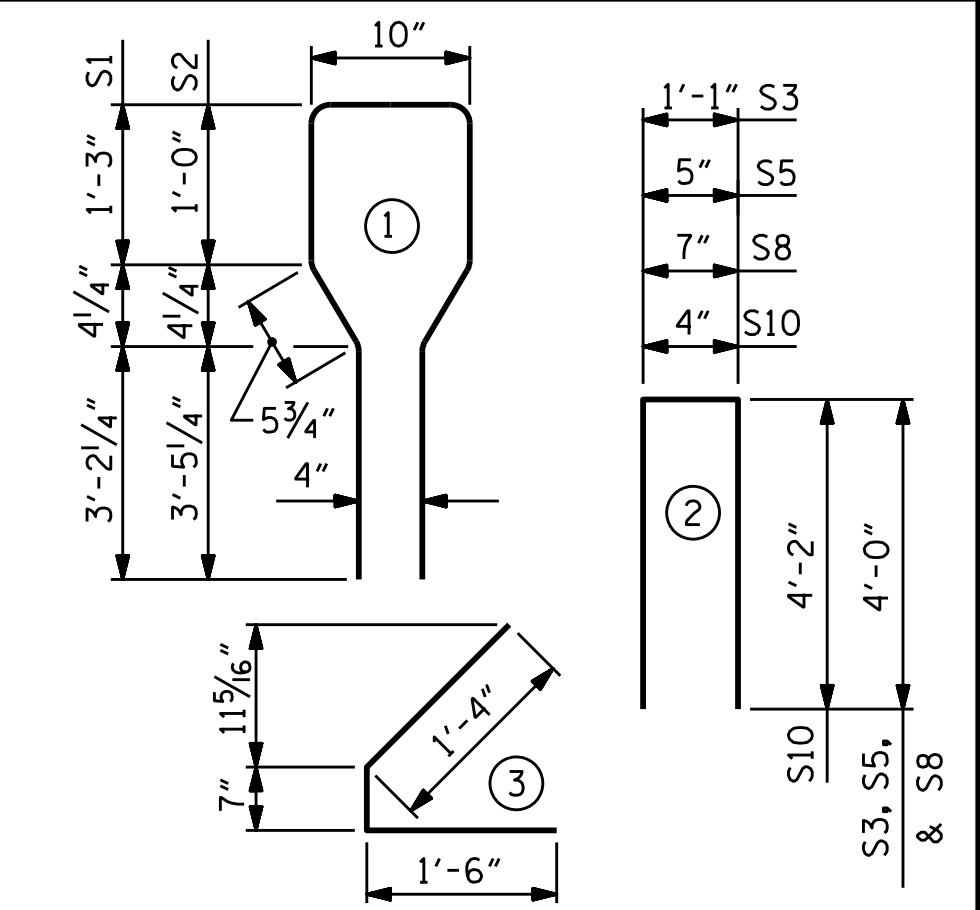

ALL BAR DIMENSIONS ARE OUT-TO-OUT.

QUANTITIES FOR ONE GIRDER

REINFORCING STEEL	7,500 PSI CONCRETE	0.6" Ø L. R. STRANDS
LBS.	C.Y.	No.
1722	19.0	38
GIRDERS REQUIRED		
NUMBER	LENGTH	TOTAL LENGTH
9	93'-4 3/4"	840'-6 3/4"

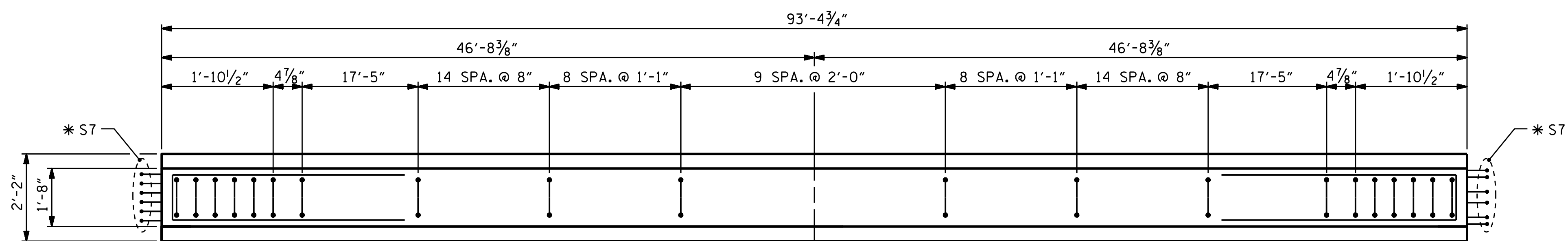

PLAN OF GIRDER

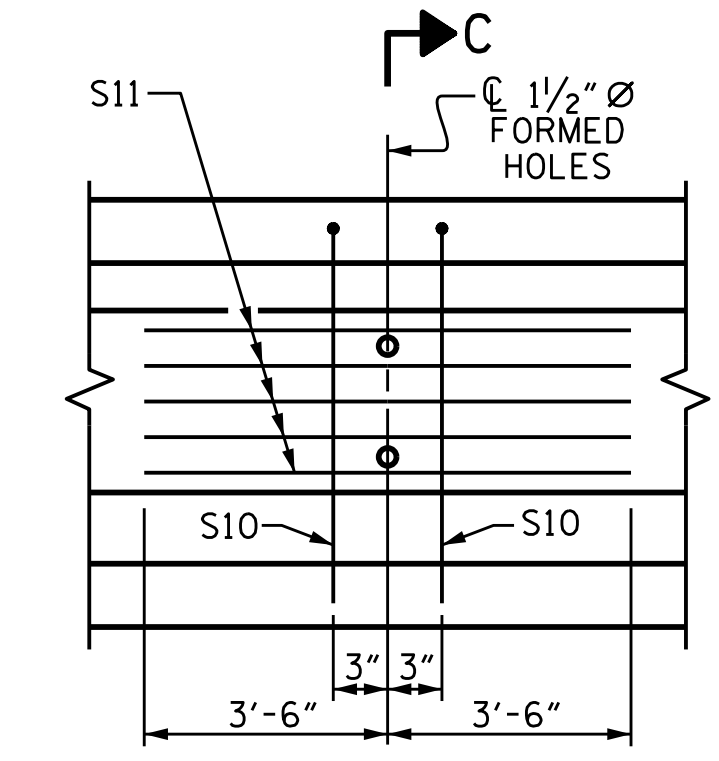

PARTIAL ELEVATION

SHOWING INTERMEDIATE DIAPHRAGM REINFORCING STEEL FOR SPAN C GIRDERS.

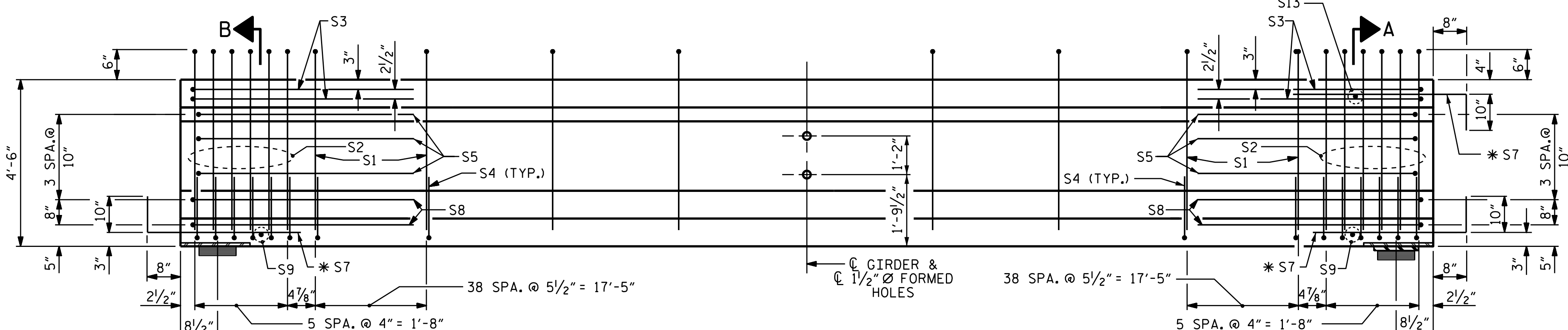

ELEVATION OF GIRDER
(SEE PARTIAL ELEVATION FOR ADDITIONAL "S" BARS)

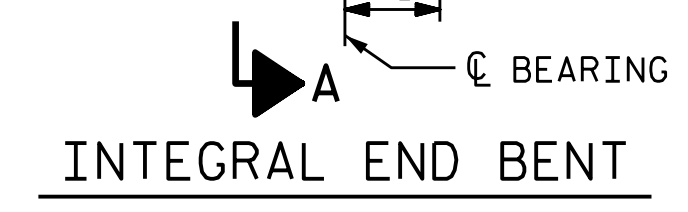

INTEGRAL END BENT

ASSEMBLED BY : H. A. LOCKLEAR	DATE : 12-15
CHECKED BY : N. D'AIUTO	DATE : 3/17/16
DRAWN BY : ELR 8/91	REV. 5/1/06R TLA/GM
CHECKED BY : GRP 8/91	REV. 10/1/11 MAA/GM
	REV. 1/15 MAA/TMG

26-JUL-2017 15:07
R:\Structures\FINAL PLANS\403.025.U-2579C.SMU.G.013.330702.dgn
mcheek

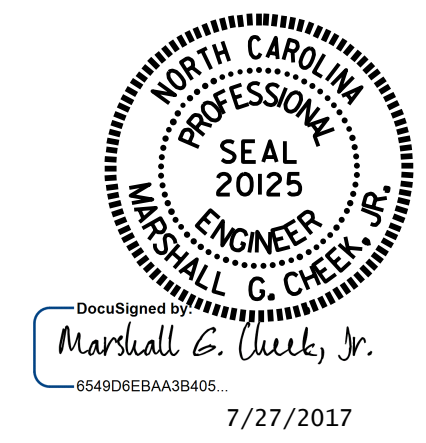

DOCUMENT NOT CONSIDERED FINAL UNLESS ALL SIGNATURES COMPLETED

PROJECT NO. U-2579C
FORSYTH COUNTY
STATION: 473+70.00 -L-

SHEET 3 OF 4

STATE OF NORTH CAROLINA
DEPARTMENT OF TRANSPORTATION
RALEIGH
STANDARD
AASHTO TYPE IV
PRESTRESSED CONCRETE GIRDER
CONTINUOUS FOR LIVE LOAD
SPAN C
(LEFT LANE)

REVISIONS						SHEET NO.
NO.	BY:	DATE:	NO.	BY:	DATE:	S3-13
1			3			TOTAL SHEETS 33
2			4			

STR. #3 STD. NO. PCG6

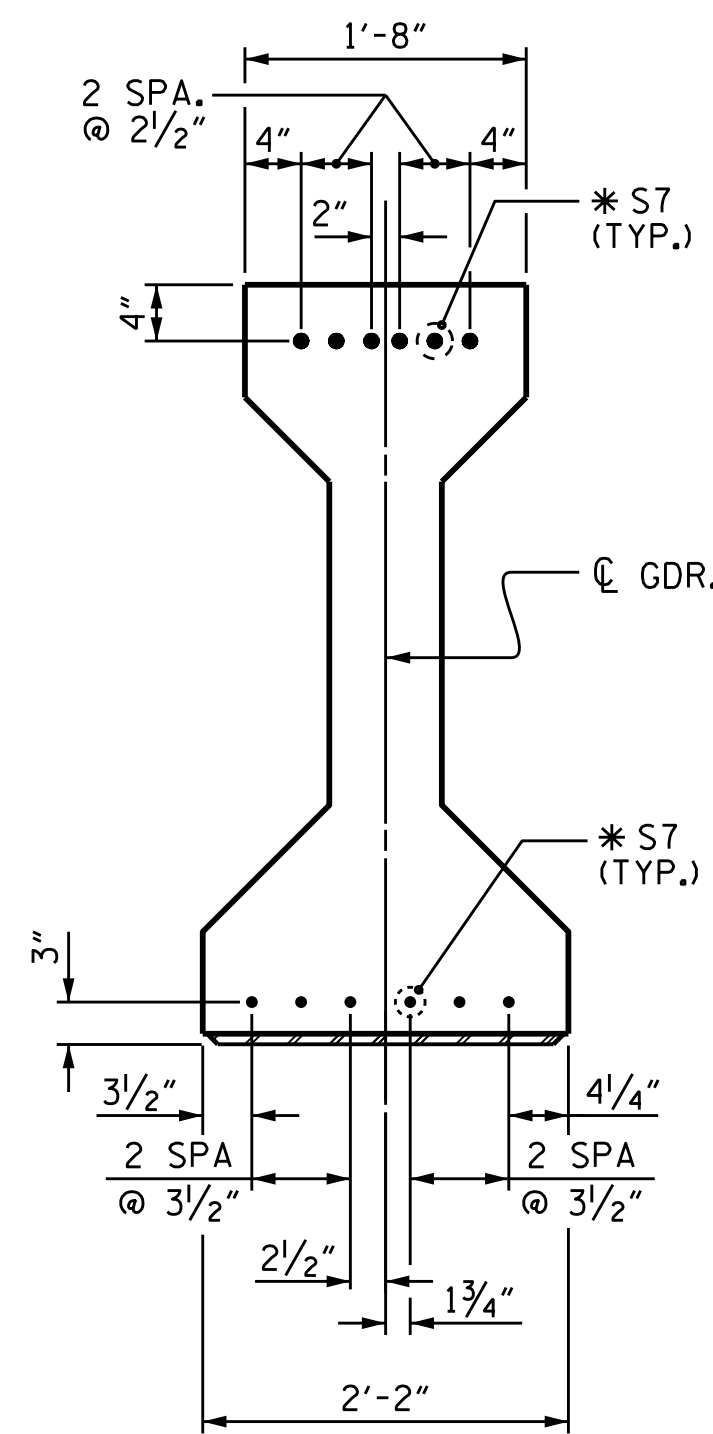

DETAIL "A"

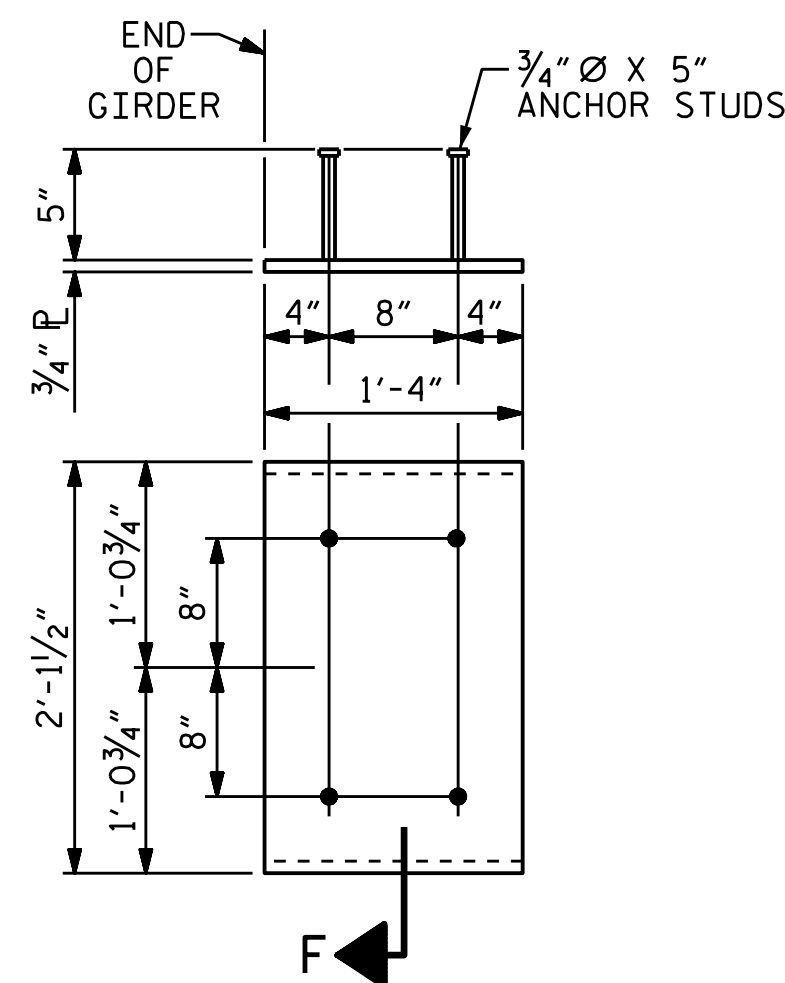

EMBEDDED PLATE "B-1" DETAILS
FOR AASHTO TYPE IV GIRDER
(2 REQ'D PER GIRDER)

NOTES

ALL PRESTRESSING STRANDS SHALL BE 7-WIRE LOW-RELAXATION GRADE 270 STRANDS AND SHALL CONFORM TO AASHTO M203 EXCEPT FOR SAMPLING REQUIREMENTS WHICH SHALL BE IN ACCORDANCE WITH THE STANDARD SPECIFICATIONS.

ALL REINFORCING STEEL SHALL BE GRADE 60.

EMBEDDED PLATE "B-1" SHALL BE GALVANIZED IN ACCORDANCE WITH THE STANDARD SPECIFICATIONS.

ANCHOR STUDS SHALL CONFORM TO AASHTO M169 GRADES 1010 THROUGH 1020 OR APPROVED EQUAL, AND SHALL MEET THE TYPE "B" REQUIREMENTS OF SUBSECTION 7.3 OF THE ANSI/AASHTO/AWS D1.5 BRIDGE WELDING CODE.

AT ENDS OF GIRDERS TO BE EMBEDDED IN CONCRETE DIAPHRAGMS OR END WALLS, PRESTRESSING STRANDS MAY EXTEND A MAXIMUM OF 2" BEYOND THE GIRDER ENDS. OTHERWISE, PRESTRESSING STRANDS SHALL BE CUT FLUSH WITH THE GIRDER ENDS.

THE TRANSFER OF LOAD FROM THE ANCHORAGES TO THE GIRDER SHALL BE DONE WHEN CONCRETE HAS REACHED A COMPRESSIVE STRENGTH OF NOT LESS THAN 4,000 PSI FOR SPAN A AND 5,800 FOR SPANS B AND C.

DEPENDING ON THE TYPE OF SYSTEM USED TO SUPPORT THE DECK SLAB FORMS, PRESET ANCHORS MAY BE NECESSARY IN THE PRESTRESSED CONCRETE GIRDER.

THE TOP SURFACE OF THE GIRDER, EXCLUDING THE OUTSIDE 4", SHALL BE RAKED TO A DEPTH OF 1/4".

FOR EMBEDDED CLIPS FOR PRESTRESSED CONCRETE GIRDERS, SEE SPECIAL PROVISIONS.

DEAD LOAD DEFLECTION TABLE FOR GIRDERS												
0.6" Ø LOW RELAXATION	SPAN A											
	GIRDERS 1 THROUGH 9											
TENTH POINTS	CL BRG.	0.1	0.2	0.3	0.4	0.5	0.6	0.7	0.8	0.9	CL BRG.	
CAMBER (GIRDER ALONE IN PLACE)	↑	0.000	0.014	0.026	0.036	0.042	0.044	0.042	0.036	0.026	0.014	0.000
* DEFLECTION DUE TO SUPERIMPOSED D.L.	↓	0.000	0.010	0.018	0.025	0.029	0.031	0.029	0.025	0.018	0.010	0.000
FINAL CAMBER	↑	0	1/16"	1/8"	1/8"	3/16"	3/16"	3/16"	1/8"	1/8"	1/16"	0

ALL VALUES ARE SHOWN IN FEET (DECIMAL FORM), EXCEPT "FINAL CAMBER", WHICH IS GIVEN IN INCHES (FRACTION FORM).
* INCLUDES FUTURE WEARING SURFACE

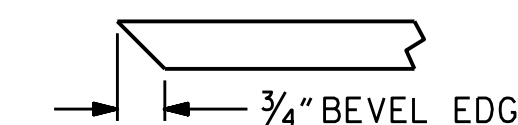

SECTION "F"
(SEE NOTES)

DEAD LOAD DEFLECTION TABLE FOR GIRDERS												
0.6" Ø LOW RELAXATION	SPAN B											
	GIRDERS 1 THROUGH 9											
TENTH POINTS	CL BRG.	0.1	0.2	0.3	0.4	0.5	0.6	0.7	0.8	0.9	CL BRG.	
CAMBER (GIRDER ALONE IN PLACE)	↑	0.000	0.054	0.103	0.141	0.165	0.173	0.165	0.141	0.103	0.054	0.000
* DEFLECTION DUE TO SUPERIMPOSED D.L.	↓	0.000	0.040	0.075	0.102	0.120	0.126	0.120	0.102	0.075	0.040	0.000
FINAL CAMBER	↑	0	3/16"	5/16"	7/16"	9/16"	9/16"	9/16"	7/16"	5/16"	3/16"	0

ALL VALUES ARE SHOWN IN FEET (DECIMAL FORM), EXCEPT "FINAL CAMBER", WHICH IS GIVEN IN INCHES (FRACTION FORM).
* INCLUDES FUTURE WEARING SURFACE

DEAD LOAD DEFLECTION TABLE FOR GIRDERS												
0.6" Ø LOW RELAXATION	SPAN C											
	GIRDERS 1 THROUGH 9											
TENTH POINTS	CL BRG.	0.1	0.2	0.3	0.4	0.5	0.6	0.7	0.8	0.9	CL BRG.	
CAMBER (GIRDER ALONE IN PLACE)	↑	0.000	0.054	0.103	0.141	0.165	0.173	0.165	0.141	0.103	0.054	0.000
* DEFLECTION DUE TO SUPERIMPOSED D.L.	↓	0.000	0.038	0.072	0.099	0.116	0.122	0.116	0.099	0.072	0.038	0.000
FINAL CAMBER	↑	0	3/16"	3/8"	1/2"	9/16"	5/8"	9/16"	1/2"	3/8"	3/16"	0

ALL VALUES ARE SHOWN IN FEET (DECIMAL FORM), EXCEPT "FINAL CAMBER", WHICH IS GIVEN IN INCHES (FRACTION FORM).
* INCLUDES FUTURE WEARING SURFACE

PROJECT NO. U-2579C
FORSYTH COUNTY
STATION: 473+70.00 -L-

SHEET 4 OF 4



STATE OF NORTH CAROLINA
DEPARTMENT OF TRANSPORTATION
RALEIGH
STANDARD
PRESTRESSED CONCRETE GIRDER
CONTINUOUS FOR LIVE LOAD
DETAILS
(LEFT LANE)

ASSEMBLED BY : J. K. BOWLES	DATE : 2/23/16
CHECKED BY : N. D'AIUTO	DATE : 3/17/16
DRAWN BY : ELR 11/91	REV. 10/1/11 MAA/GM
CHECKED BY : GRP 11/91	REV. 1/15 MAA/TMG
	REV. 2/15 MAA/TMG

DOCUMENT NOT CONSIDERED
FINAL UNLESS ALL
SIGNATURES COMPLETED

REVISIONS						SHEET NO.
NO.	BY:	DATE:	NO.	BY:	DATE:	S3-14
1			3			TOTAL SHEETS 33
2			4			

STRUCTURAL STEEL NOTES

ALL INTERMEDIATE DIAPHRAGM STEEL AND CONNECTOR PLATES SHALL BE AASHTO M270 GRADE 50 OR APPROVED EQUAL.

TENSION ON THE ASTM A325 BOLTS THROUGH THE CHANNEL MEMBER SHALL BE CALIBRATED USING DIRECT TENSION INDICATOR WASHERS IN ACCORDANCE WITH THE STANDARD SPECIFICATIONS.

TENSION ON THE ASTM A449 BOLTS THROUGH THE GIRDER WEB SHALL BE SNUG TIGHTENED FOLLOWED BY AN ADDITIONAL 1/4 TURN.

THE PLATES, BENT PLATES, CHANNELS, AND ANGLES SHALL BE GALVANIZED OR METALLIZED IN ACCORDANCE WITH THE STANDARD SPECIFICATIONS. FOR THERMAL SPRAYED COATINGS (METALLIZATION), SEE SPECIAL PROVISIONS.

FOR METALLIZATION, APPLY AN 8 MIL THICK 99.99 PERCENT ZINC (W-Zn-1) THERMAL SPRAYED COATING WITH A 0.5 MIL THICK SEAL COAT TO ALL STEEL DIAPHRAGM SURFACES IN ACCORDANCE WITH THE THERMAL SPRAYED COATINGS SPECIAL PROVISION AND SECTION 442 OF THE STANDARD SPECIFICATIONS.

GALVANIZE THE HIGH STRENGTH BOLTS, NUTS, WASHERS AND DIRECT TENSION INDICATORS IN ACCORDANCE WITH THE STANDARD SPECIFICATIONS.

USE AN ASTM F436 HARDENED WASHER WITH STANDARD AND SLOTTED HOLES UNDER EACH BOLT HEAD AND NUT.

FOR BOLTS THROUGH THE GIRDER WEB, PROVIDE SUFFICIENT LENGTH OF THREADS ON ALL BOLTS TO ACCOMMODATE WASHERS AND THE THICKNESS OF CONNECTING MEMBER PLUS AT LEAST 1/4" PROJECTION BEYOND THE NUT.

INTERMEDIATE DIAPHRAGM ASSEMBLY SHALL COMPLY WITH SECTION 1072 OF THE STANDARD SPECIFICATIONS.

SUBMIT TWO SETS OF WORKING DRAWINGS FOR THE INTERMEDIATE DIAPHRAGM ASSEMBLY FOR REVIEW, COMMENTS AND ACCEPTANCE. AFTER REVIEW, COMMENTS, AND ACCEPTANCE, SUBMIT SEVEN SETS FOR DISTRIBUTION.

IN THE EXTERIOR BAYS, PLACE TEMPORARY STRUTS BETWEEN PRESTRESSED GIRDERS ADJACENT TO THE STEEL DIAPHRAGMS. STRUTS SHALL REMAIN IN PLACE 3 DAYS AFTER CONCRETE IS PLACED.

THE COST OF THE STEEL DIAPHRAGMS AND ASSEMBLIES SHALL BE INCLUDED IN THE UNIT PRICE BID FOR 54" PRESTRESSED CONCRETE GIRDERS.

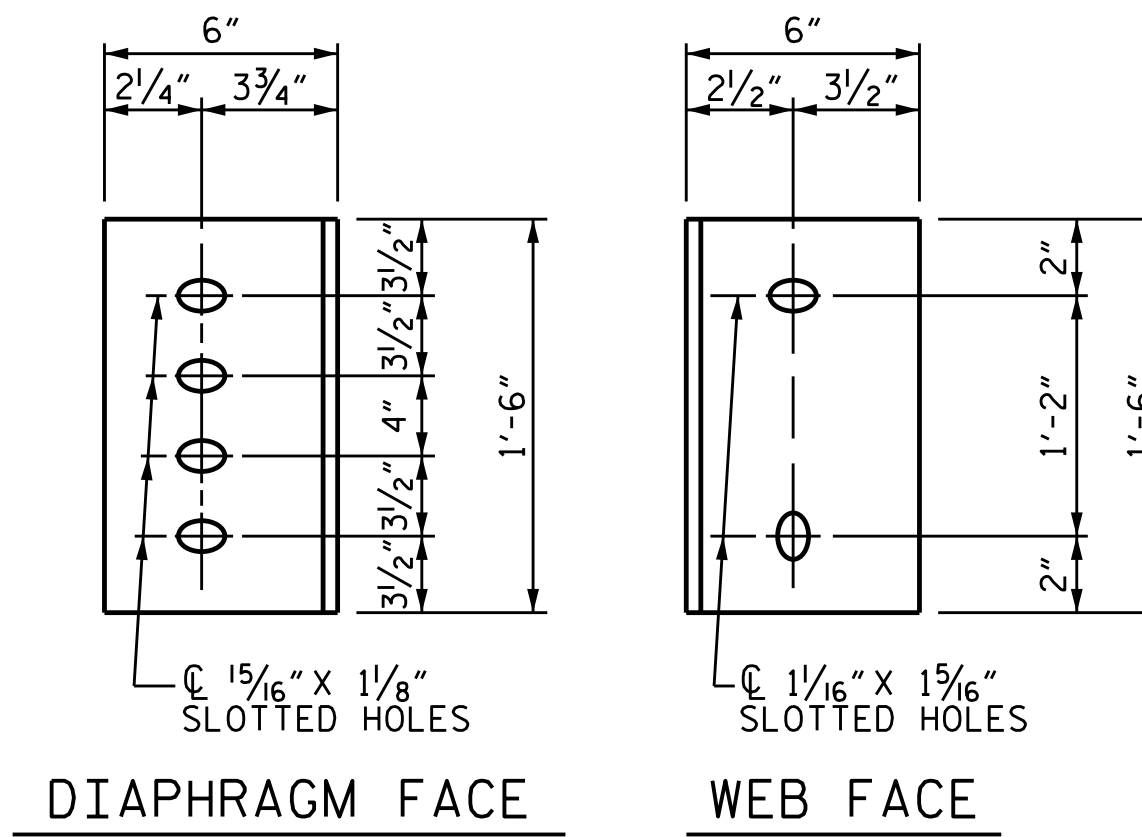

DIAPHRAGM FACE
WEB FACE
CONNECTOR PLATE DETAILS

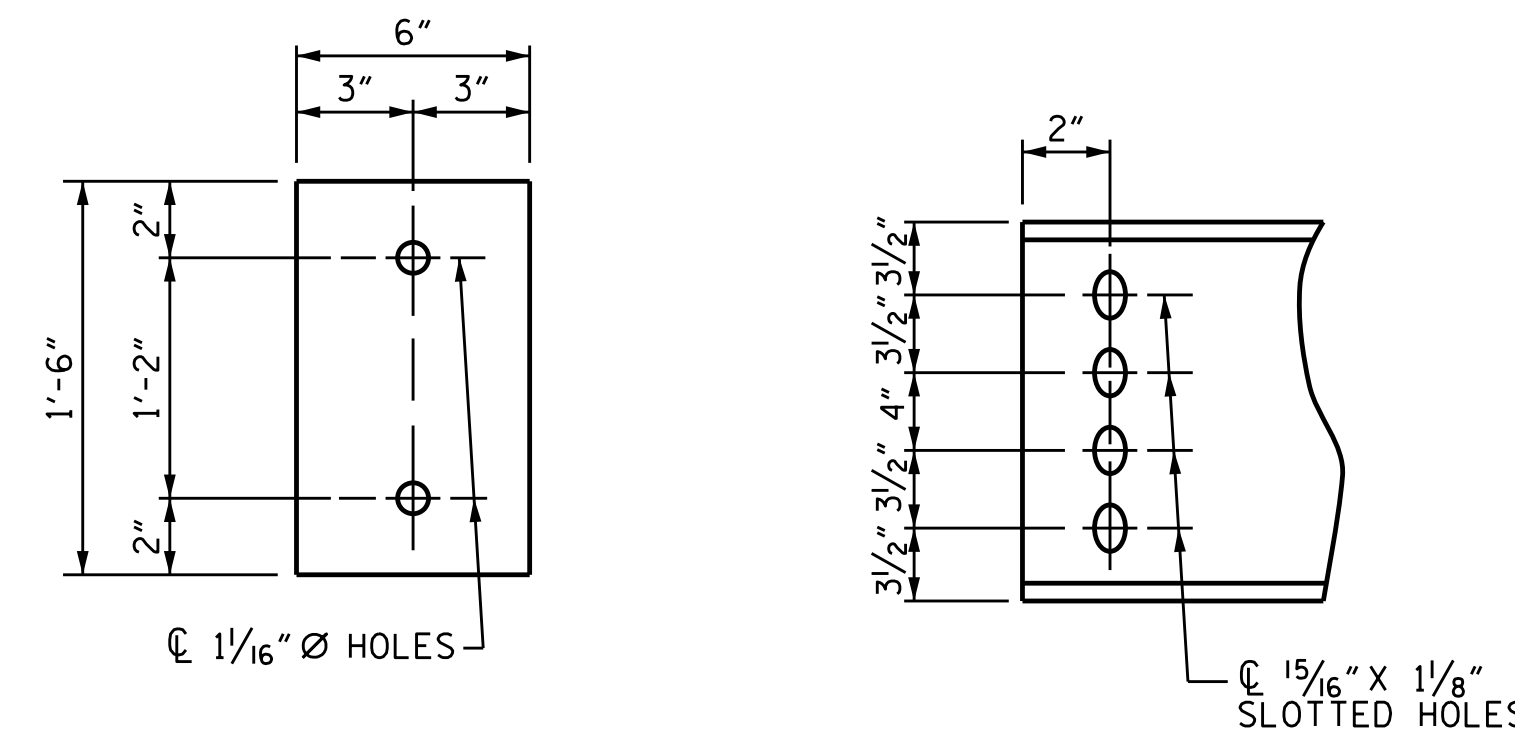
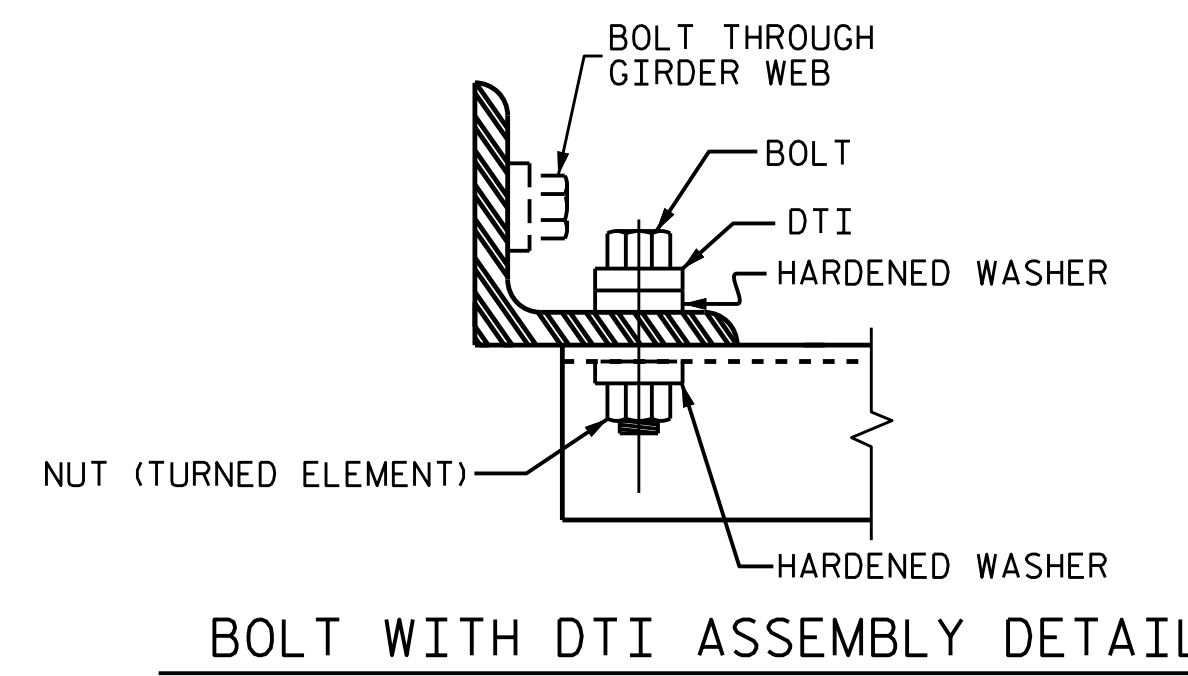
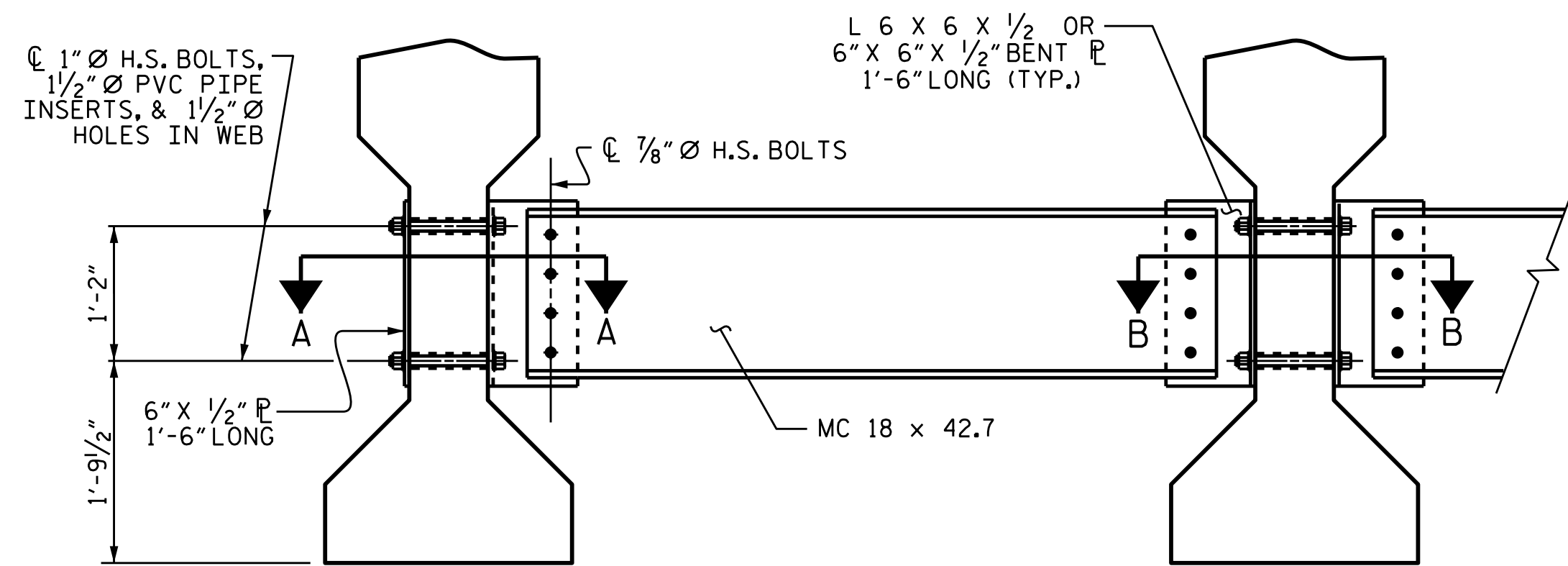

PLATE DETAILS
CHANNEL END



BOLT WITH DTI ASSEMBLY DETAIL



EXTERIOR GIRDER
INTERIOR GIRDER
PART SECTION AT INTERMEDIATE DIAPHRAGM

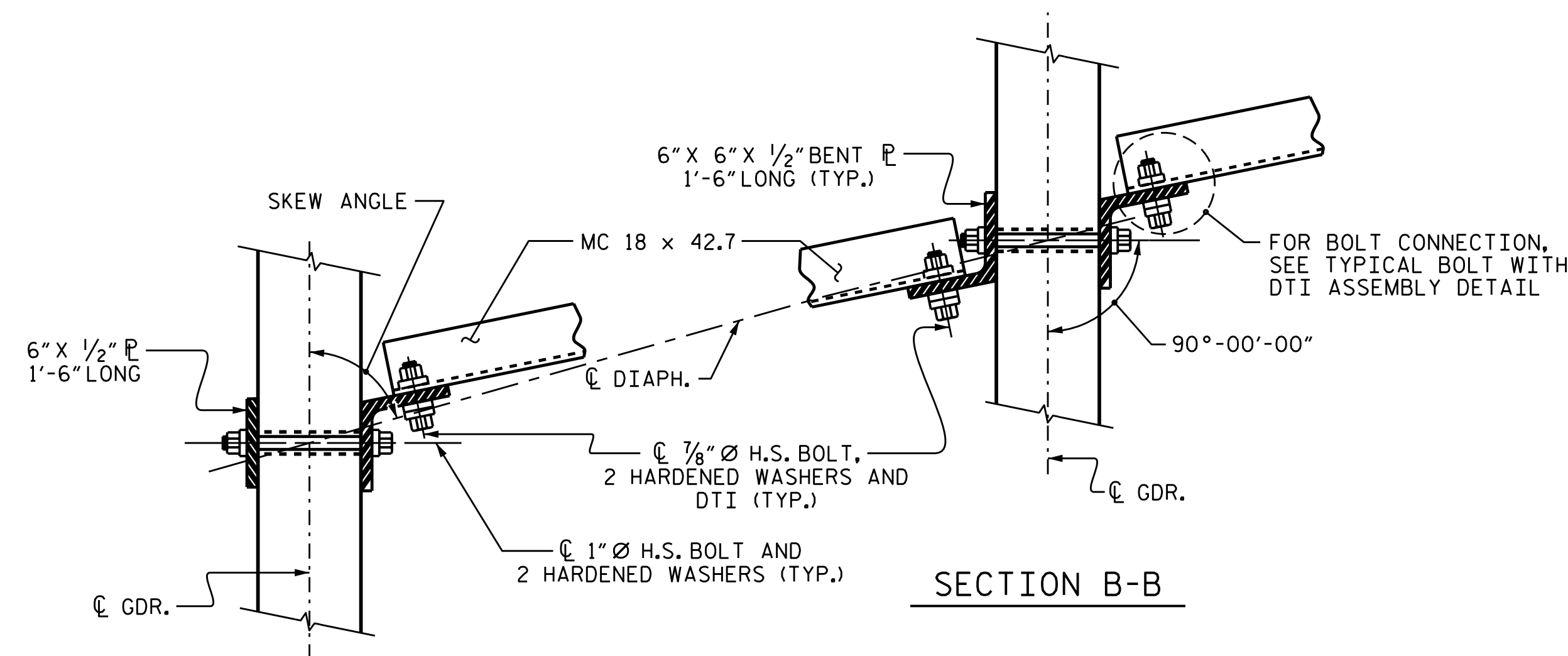

SECTION A-A
SECTION B-B
CONNECTION DETAILS

PROJECT NO. U-2579C
FORSYTH COUNTY
STATION: 473+70.00 -L-

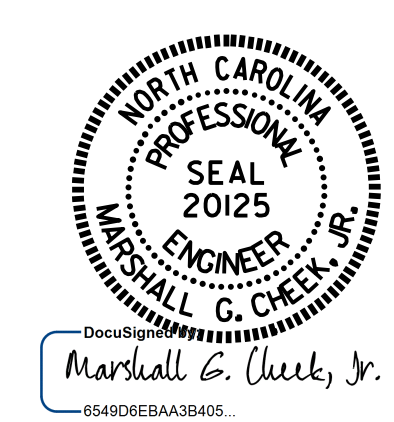

STATE OF NORTH CAROLINA
DEPARTMENT OF TRANSPORTATION
RALEIGH

STANDARD
INTERMEDIATE
STEEL DIAPHRAGMS
FOR TYPE IV PRESTRESSED
CONCRETE GIRDERS
(LEFT LANE)

ASSEMBLED BY : H. A. LOCKLEAR	DATE : 10-15
CHECKED BY : N. D'AIUTO	DATE : 3/17/16
DRAWN BY : TLA 6/05	ADDED 10/21/05
CHECKED BY : VC 6/05	REV. 5/1/06RRR KMM/GM
	REV. 10/1/11 MAA/GM

DOCUMENT NOT CONSIDERED FINAL UNLESS ALL SIGNATURES COMPLETED

REVISIONS						SHEET NO.
NO.	BY:	DATE:	NO.	BY:	DATE:	S3-15
1			3			TOTAL SHEETS
2			4			33

NOTES

AT ALL FIXED POINTS OF SUPPORT, NUTS FOR ANCHOR BOLTS ARE TO BE TIGHTENED FINGER TIGHT AND THEN BACKED OFF 1/2 TURN. THE THREAD OF THE NUT AND BOLT SHALL THEN BE BURRED WITH A SHARP POINTED TOOL.

STEEL SOLE PLATES, ANCHOR BOLTS, AND NUTS SHALL BE GALVANIZED IN ACCORDANCE WITH THE STANDARD SPECIFICATIONS.

PRIOR TO WELDING, GRIND THE GALVANIZED SURFACE OF THE PORTION OF THE EMBEDDED PLATE AND SOLE PLATE THAT ARE TO BE WELDED. AFTER WELDING, DAMAGED GALVANIZED SURFACES SHALL BE REPAIRED IN ACCORDANCE WITH THE STANDARD SPECIFICATIONS.

WHEN WELDING THE SOLE PLATE TO THE EMBEDDED PLATE IN THE GIRDER, USE TEMPERATURE INDICATING WAX PENS, OR OTHER SUITABLE MEANS, TO ENSURE THAT THE TEMPERATURE OF THE SOLE PLATE DOES NOT EXCEED 300°F. TEMPERATURES ABOVE THIS MAY DAMAGE THE ELASTOMER.

SOLE PLATE "P", BOLTS, AND NUTS SHALL BE INCLUDED IN THE PAY ITEM FOR PRESTRESSED CONCRETE GIRDERS.

ANCHOR BOLTS SHALL MEET THE REQUIREMENTS OF ASTM A449. NUTS SHALL MEET THE REQUIREMENTS OF AASHTO M291-DH OR AASHTO M292-2H. NO SHOP DRAWINGS ARE REQUIRED FOR ANCHOR BOLTS AND NUTS. SHOP INSPECTION IS REQUIRED.

ALL SURFACES OF BEARING PLATES SHALL BE SMOOTH AND STRAIGHT.

THE ELASTOMER IN THE STEEL REINFORCED BEARINGS SHALL HAVE A SHEAR MODULUS OF 0.160 KSI, IN ACCORDANCE WITH AASHTO M251.

FOR STEEL REINFORCED ELASTOMERIC BEARINGS, SEE SPECIAL PROVISIONS.

MAXIMUM ALLOWABLE SERVICE LOADS	
D.L.+L.L. (NO IMPACT)	
TYPE IV	225 k
TYPE V	365 k

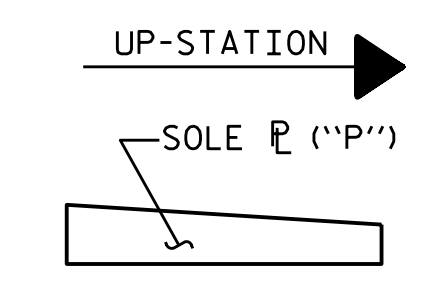
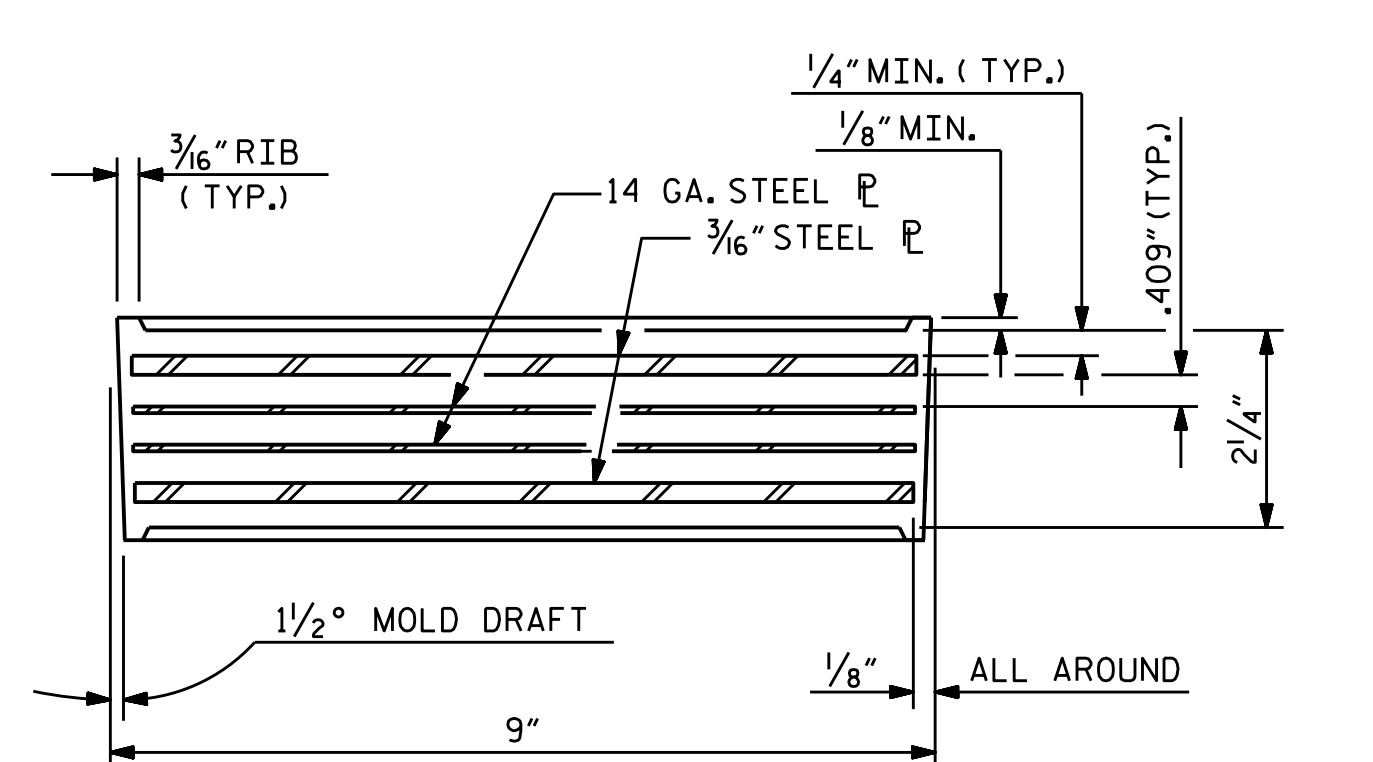
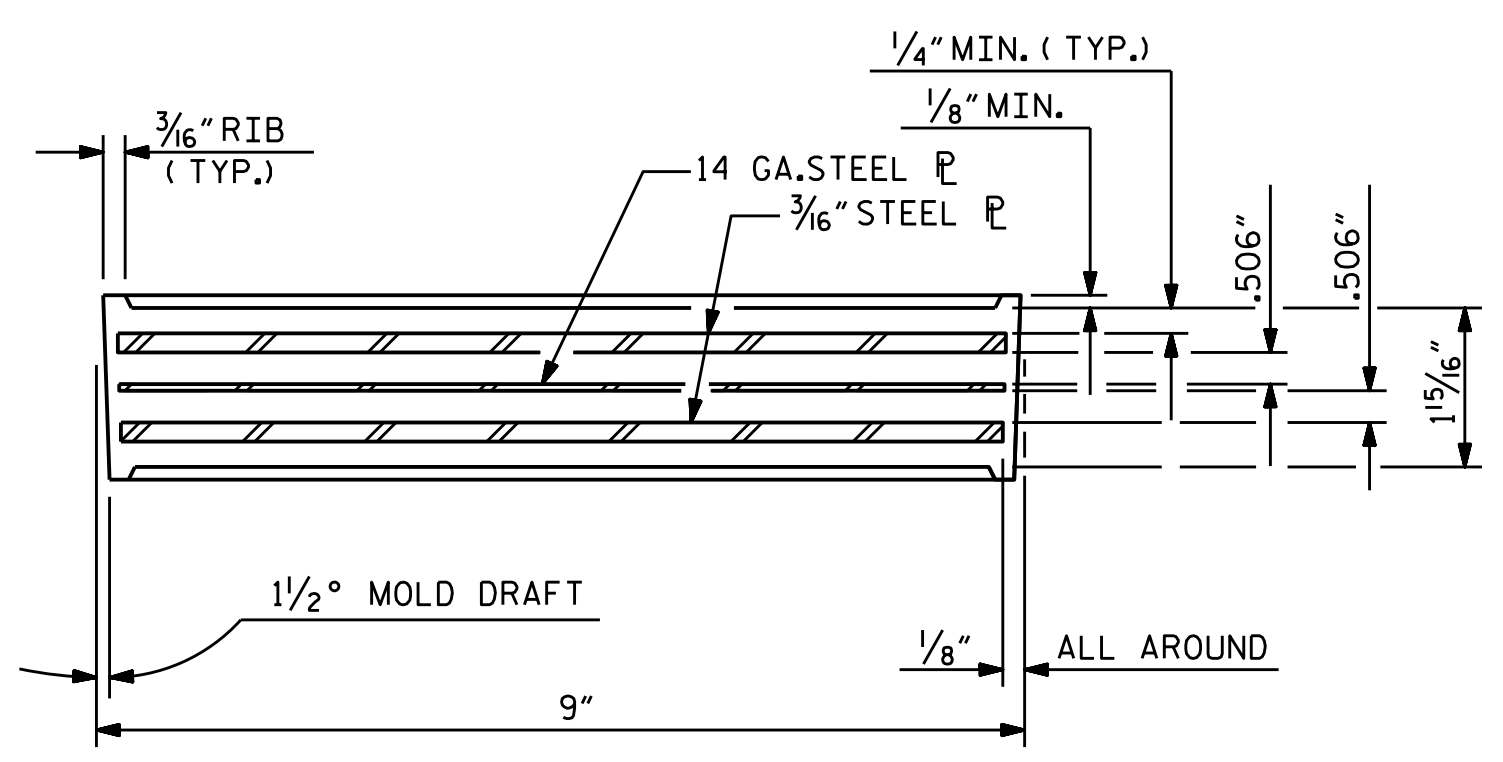
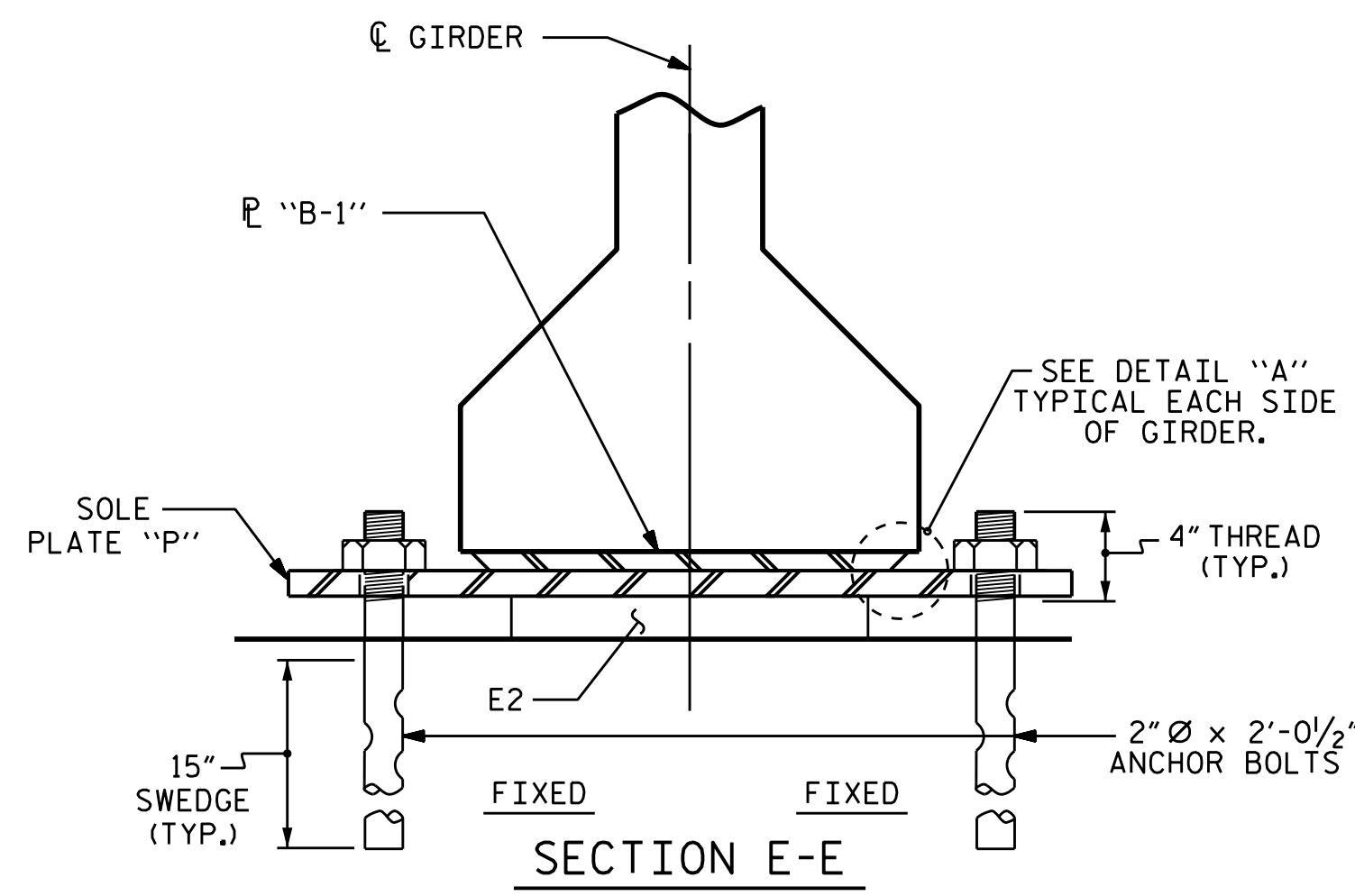
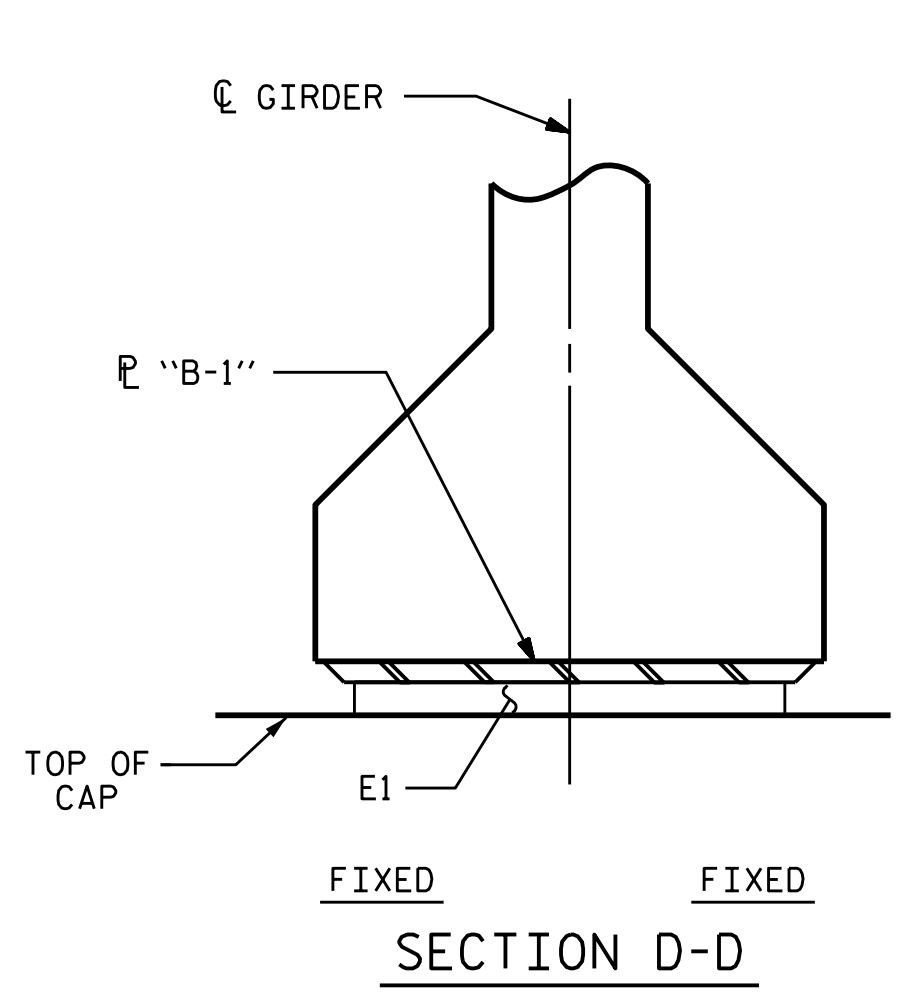

SOLE PLATE PLACEMENT DETAIL

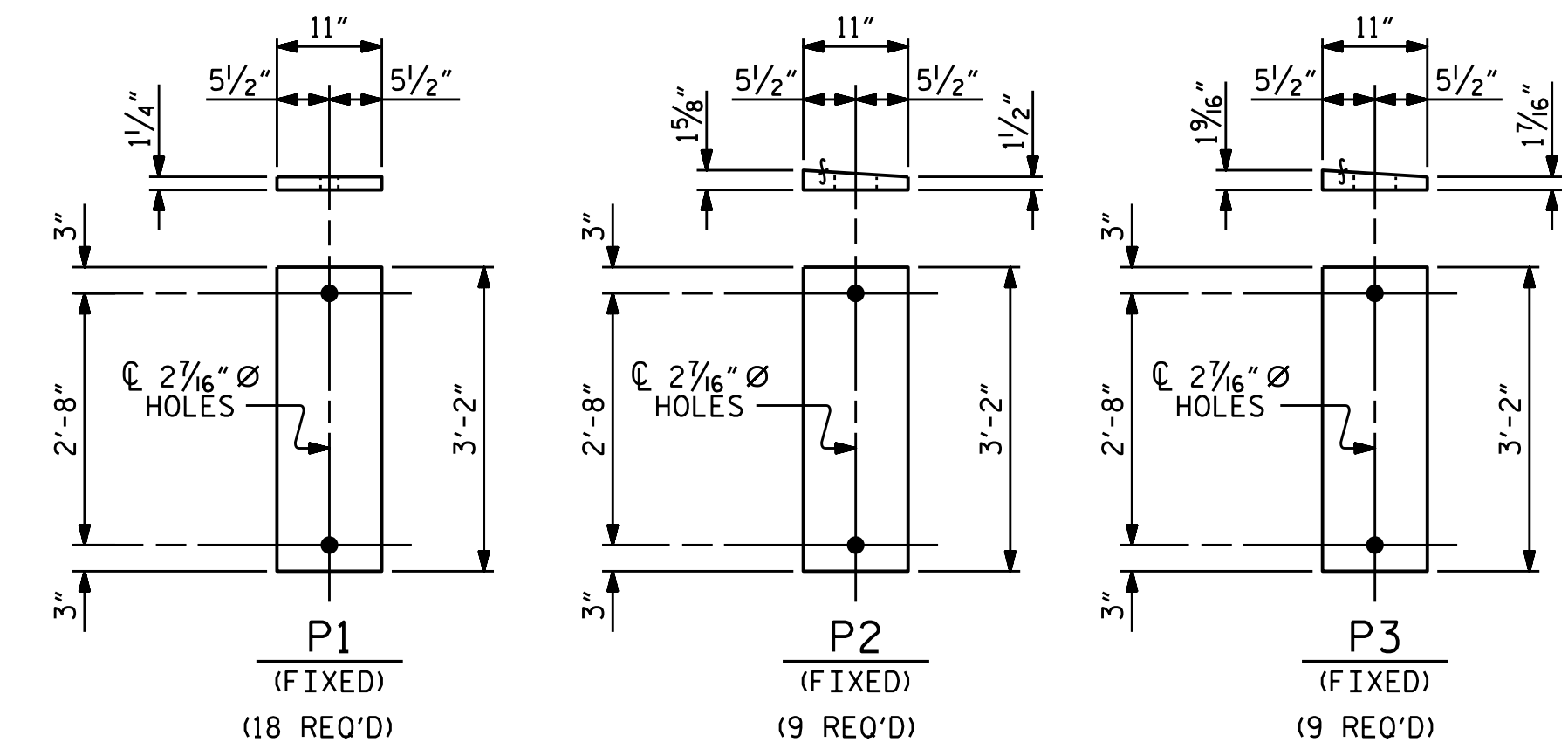

SOLE PLATE DETAILS ("P")

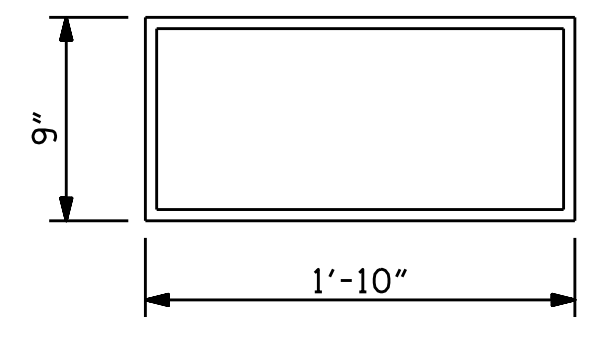

E1 (18 REQ'D)

PLAN VIEW OF ELASTOMERIC BEARING

TYPE IV

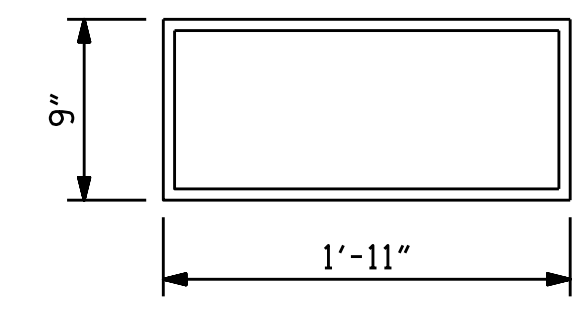

E2 (36 REQ'D)

PLAN VIEW OF ELASTOMERIC BEARING

TYPE V

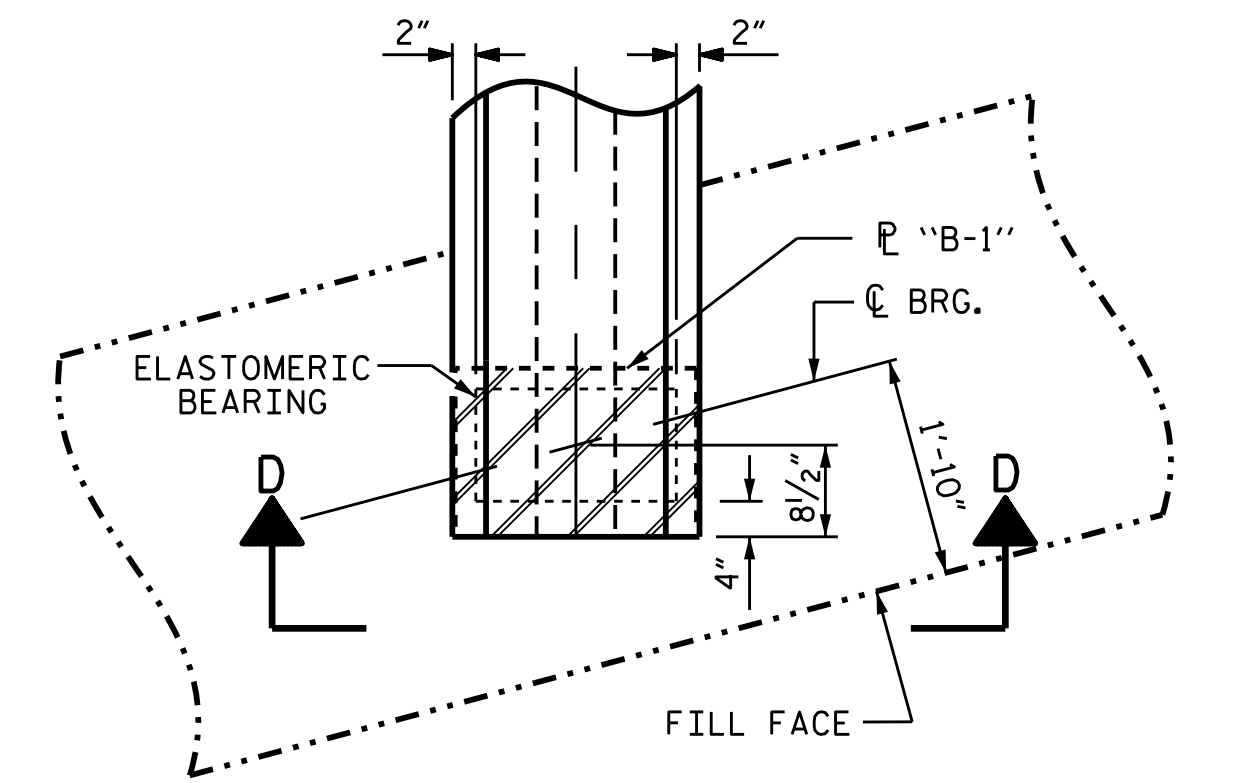

PLAN VIEW AT INTEGRAL END BENT

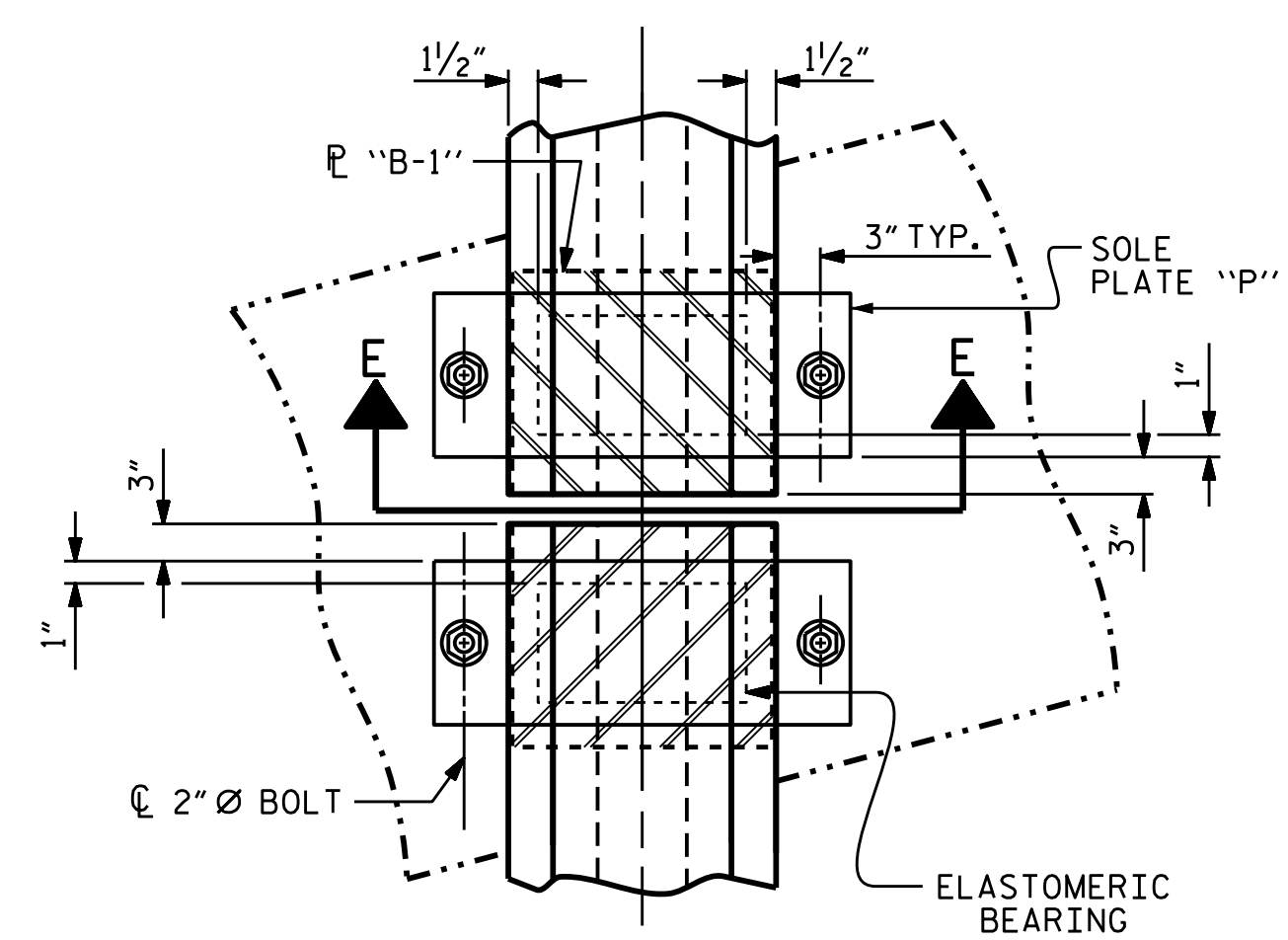

PLAN VIEW AT BENT

(SHOWING CONTINUOUS BENT)

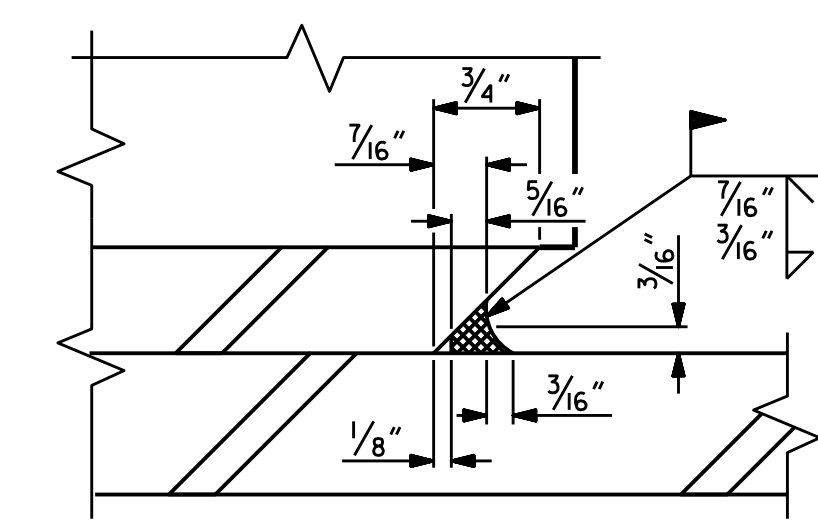

DETAIL "A"

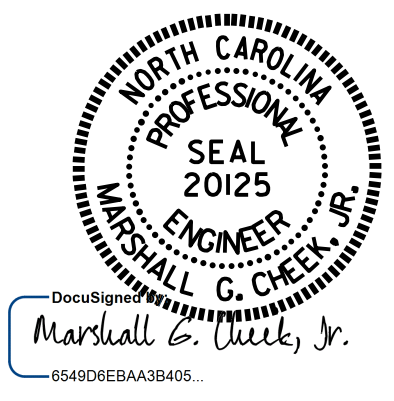

7/27/2017

PROJECT NO. U-2579C
 FORSYTH COUNTY
 STATION: 473+70.00 -L-

STATE OF NORTH CAROLINA
 DEPARTMENT OF TRANSPORTATION
 RALEIGH
 STANDARD
 ELASTOMERIC BEARING
 DETAILS
 PRESTRESSED CONCRETE GIRDER
 SUPERSTRUCTURE
 (LEFT LANE)

ASSEMBLED BY : J. K. BOWLES	DATE : 2/1/16
CHECKED BY : N. D'AIUTO	DATE : 3/17/16
DRAWN BY : EEM 2/97	REV. 10/1/11 MAA/GM
CHECKED BY : VAP 2/97	REV. 6/13 AAC/MAA
	REV. 1/15 MAA/TMG

DOCUMENT NOT CONSIDERED FINAL UNLESS ALL SIGNATURES COMPLETED

REVISIONS						SHEET NO.	
NO.	BY:	DATE:	NO.	BY:	DATE:	S3-16	
1			3			TOTAL SHEETS 33	
2			4				

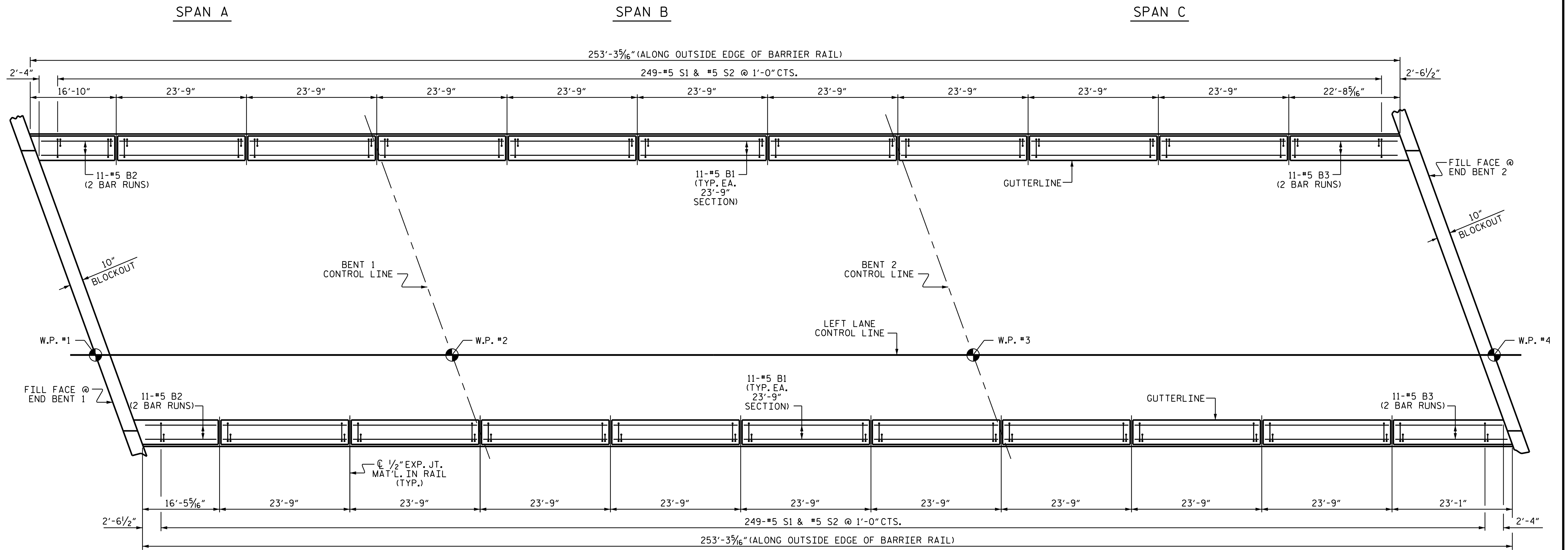

PLAN OF CONCRETE BARRIER RAIL

PROJECT NO. U-2579C
 FORSYTH COUNTY
 STATION: 473+70.00 -L-

SHEET 1 OF 2

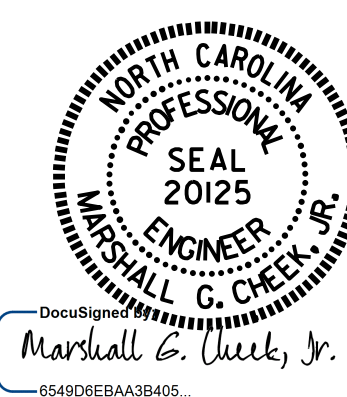

7/27/2017

STATE OF NORTH CAROLINA
 DEPARTMENT OF TRANSPORTATION
 RALEIGH

3'-6" CONCRETE
 BARRIER RAIL
 (LEFT LANE)

DRAWN BY : T. L. AVERETTE DATE : 3/02/17
 CHECKED BY : H. T. BARBOUR DATE : 3/14/17

DOCUMENT NOT CONSIDERED
 FINAL UNLESS ALL
 SIGNATURES COMPLETED

REVISIONS						SHEET NO.	
NO.	BY:	DATE:	NO.	BY:	DATE:	TOTAL SHEETS	
1			3			S3-17	
2			4			33	

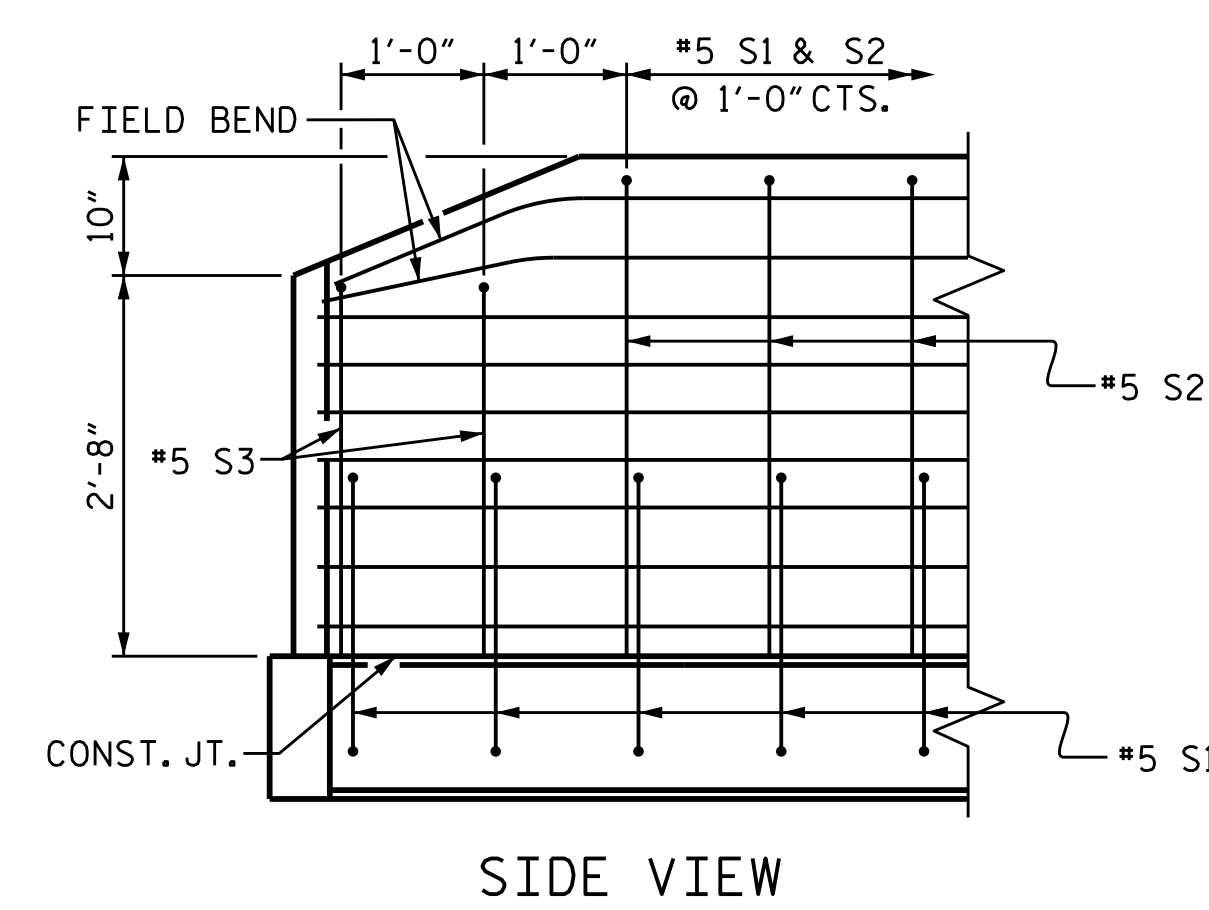
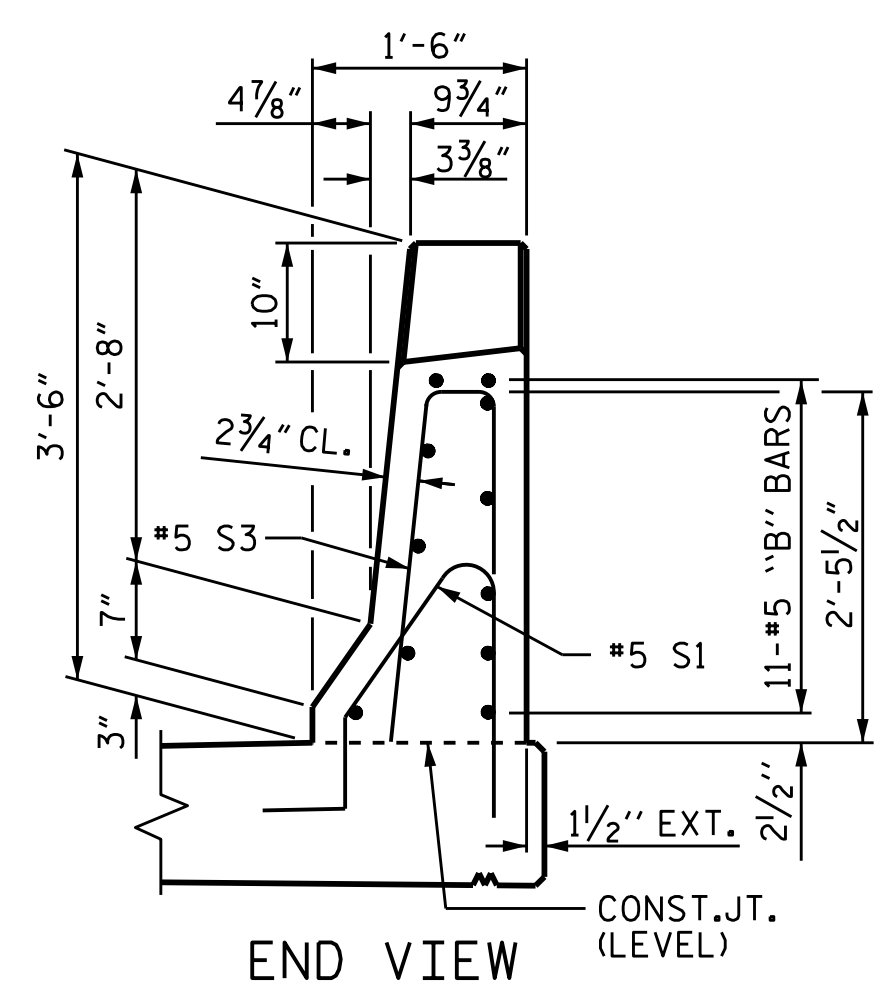
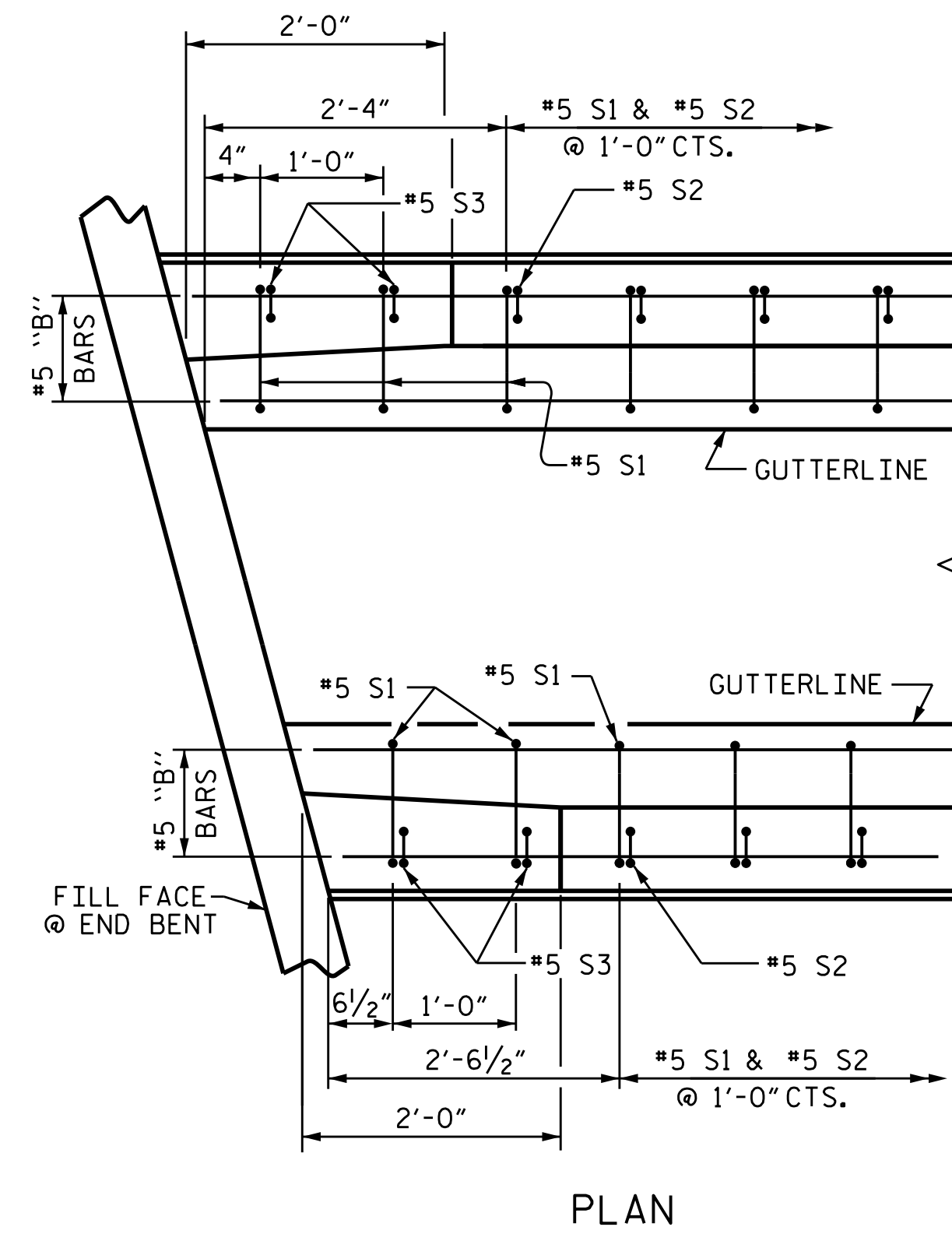

END OF RAIL DETAILS

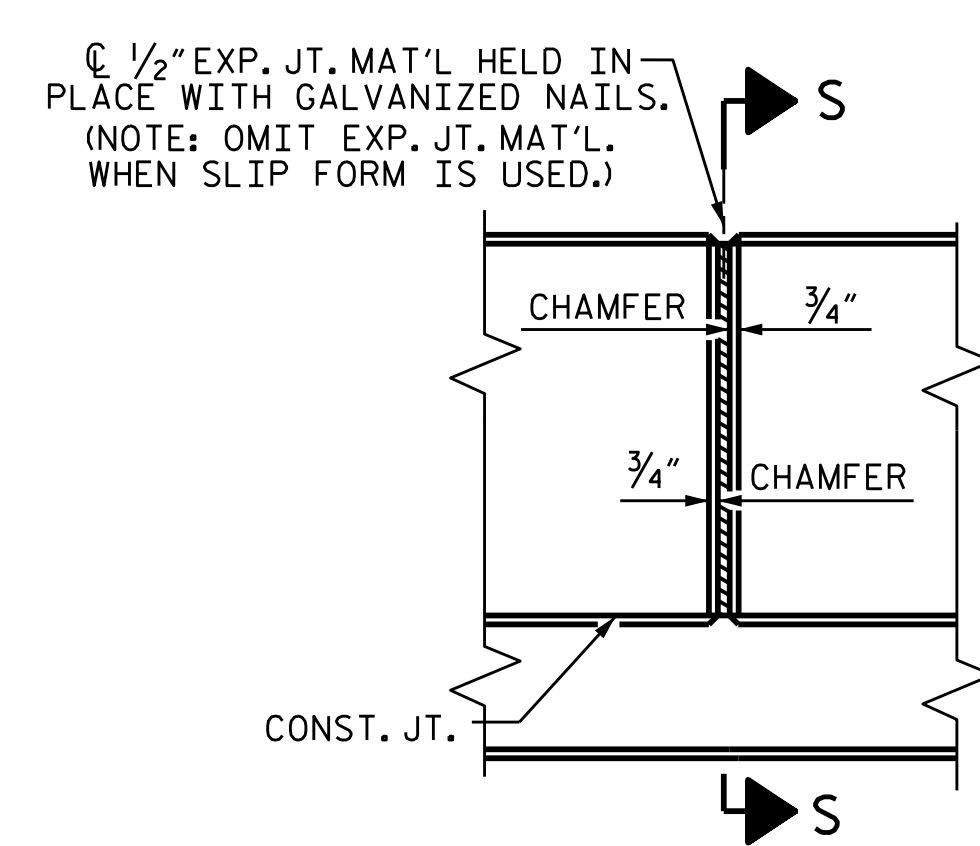
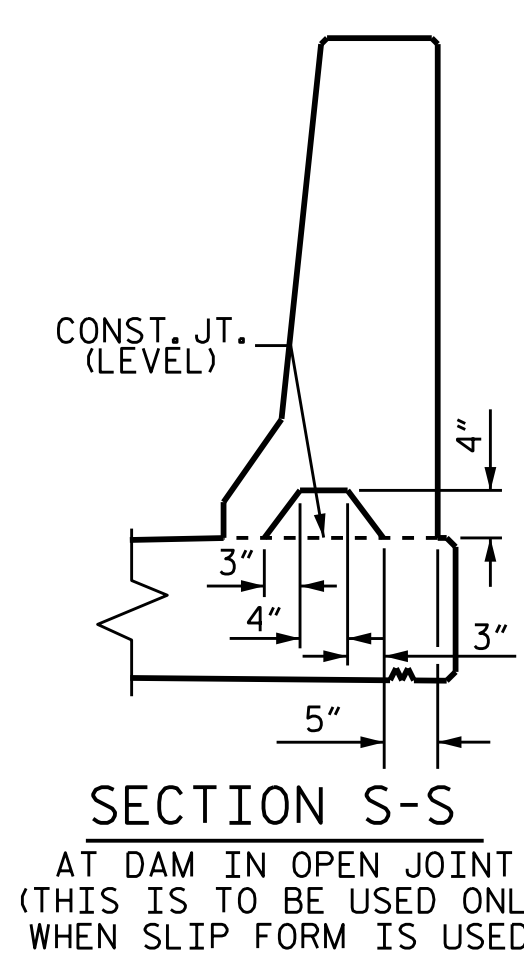
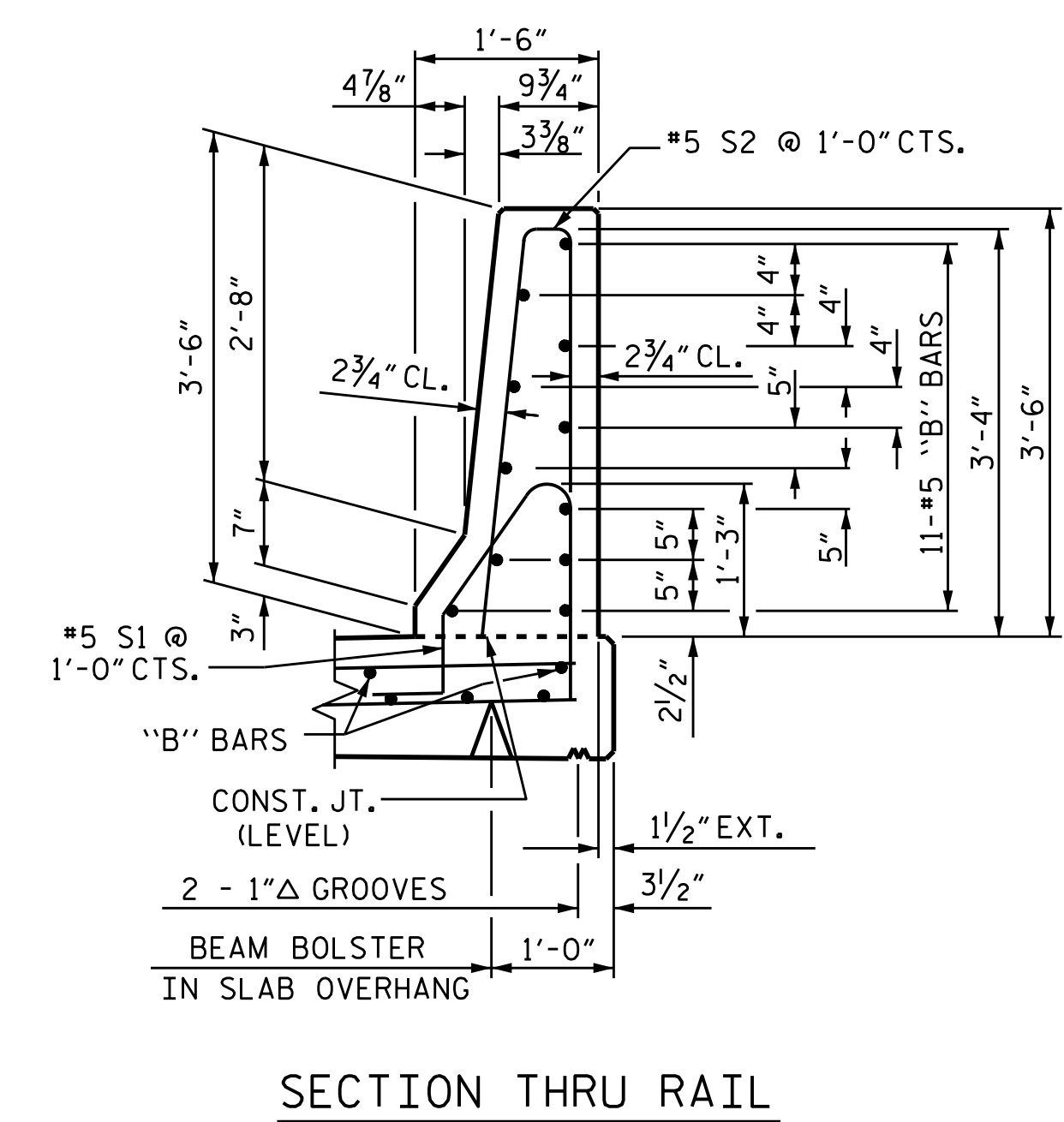

SECTION THRU RAIL

ELEVATION AT EXPANSION JOINTS

BARRIER RAIL DETAILS

NOTES

THE BARRIER RAIL IN THE CONTINUOUS UNIT SHALL NOT BE CAST UNTIL ALL SLAB CONCRETE IN THAT UNIT HAS BEEN CAST AND HAS REACHED A MINIMUM COMPRESSIVE STRENGTH OF 3,000 PSI.

ALL REINFORCING STEEL IN BARRIER RAILS SHALL BE EPOXY COATED.

GROOVED CONTRACTION JOINTS, 1/2" IN DEPTH, SHALL BE TOOLED IN ALL EXPOSED FACES OF THE BARRIER RAIL AND IN ACCORDANCE WITH ARTICLE 825-10(B) OF THE STANDARD SPECIFICATIONS, THE CONTRACTION JOINT SHALL BE LOCATED AT EACH THIRD POINT BETWEEN BARRIER RAIL EXPANSION JOINTS. ONLY ONE CONTRACTION JOINT IS REQUIRED AT MIDPOINT OF BARRIER RAIL SEGMENTS LESS THAN 20 FEET IN LENGTH AND NO CONTRACTION JOINTS ARE REQUIRED FOR THOSE SEGMENTS LESS THAN 10 FEET IN LENGTH.

THE #5 S1 AND #5 S2 BARS MAY BE SHIFTED SLIGHTLY IN ORDER TO MAINTAIN 2" MINIMUM CLEARANCE TO THE 1/2" EXPANSION JOINT MATERIAL IN THE BARRIER RAIL.

BAR TYPES

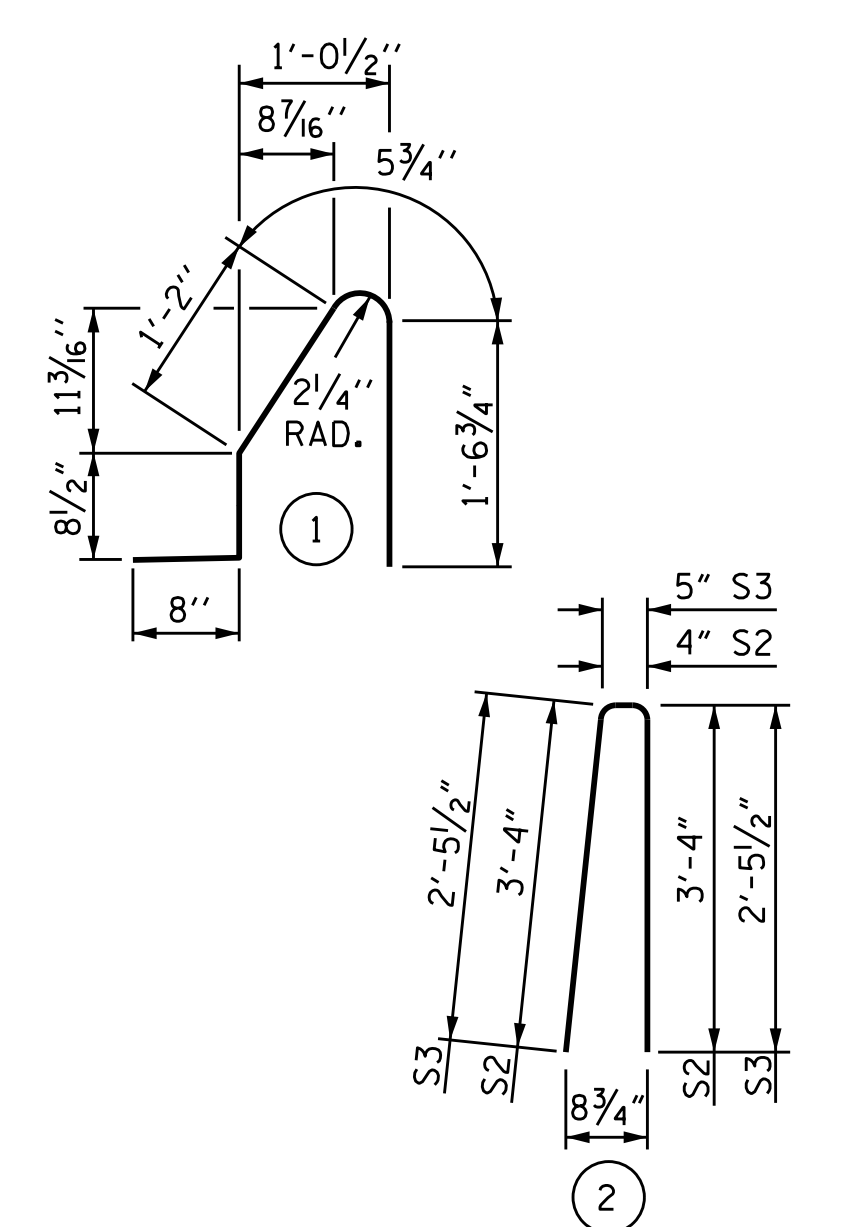

ALL BAR DIMENSIONS ARE OUT TO OUT.

BILL OF MATERIAL

FOR CONCRETE BARRIER RAIL ONLY					
BAR	NO.	SIZE	TYPE	LENGTH	WEIGHT
* B1	198	#5	STR	23'-4"	4819
* B2	44	#5	STR	9'-11"	455
* B3	44	#5	STR	13'-1"	600
* S1	506	#5	1	4'-7"	2419
* S2	498	#5	2	7'-0"	3636
* S3	8	#5	2	5'-4"	45
* EPOXY COATED REINFORCING STEEL				LBS.	11,974
CLASS AA CONCRETE				C.Y.	68.9
CONCRETE BARRIER RAIL				LN. FT.	506.55

PROJECT NO. U-2579C
 FORSYTH COUNTY
 STATION: 473+70.00 -L-

SHEET 2 OF 2

STATE OF NORTH CAROLINA
 DEPARTMENT OF TRANSPORTATION
 RALEIGH

3'-6" CONCRETE BARRIER RAIL
 (LEFT LANE)

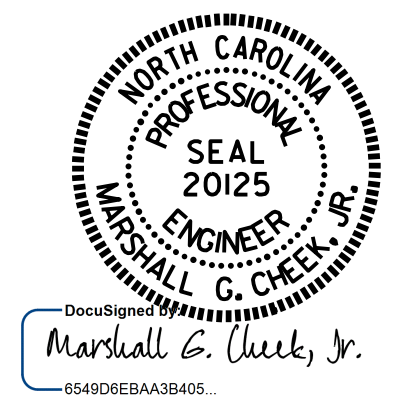

7/27/2017

DRAWN BY : T. L. AVERETTE DATE : 3/02/17
 CHECKED BY : H. T. BARBOUR DATE : 3/14/17
 DESIGN ENGINEER OF RECORD : H. A. LOCKLEAR DATE : 6/2017

DOCUMENT NOT CONSIDERED FINAL UNLESS ALL SIGNATURES COMPLETED

REVISIONS						SHEET NO.
NO.	BY:	DATE:	NO.	BY:	DATE:	S3-18
1			3			TOTAL SHEETS
2			4			33

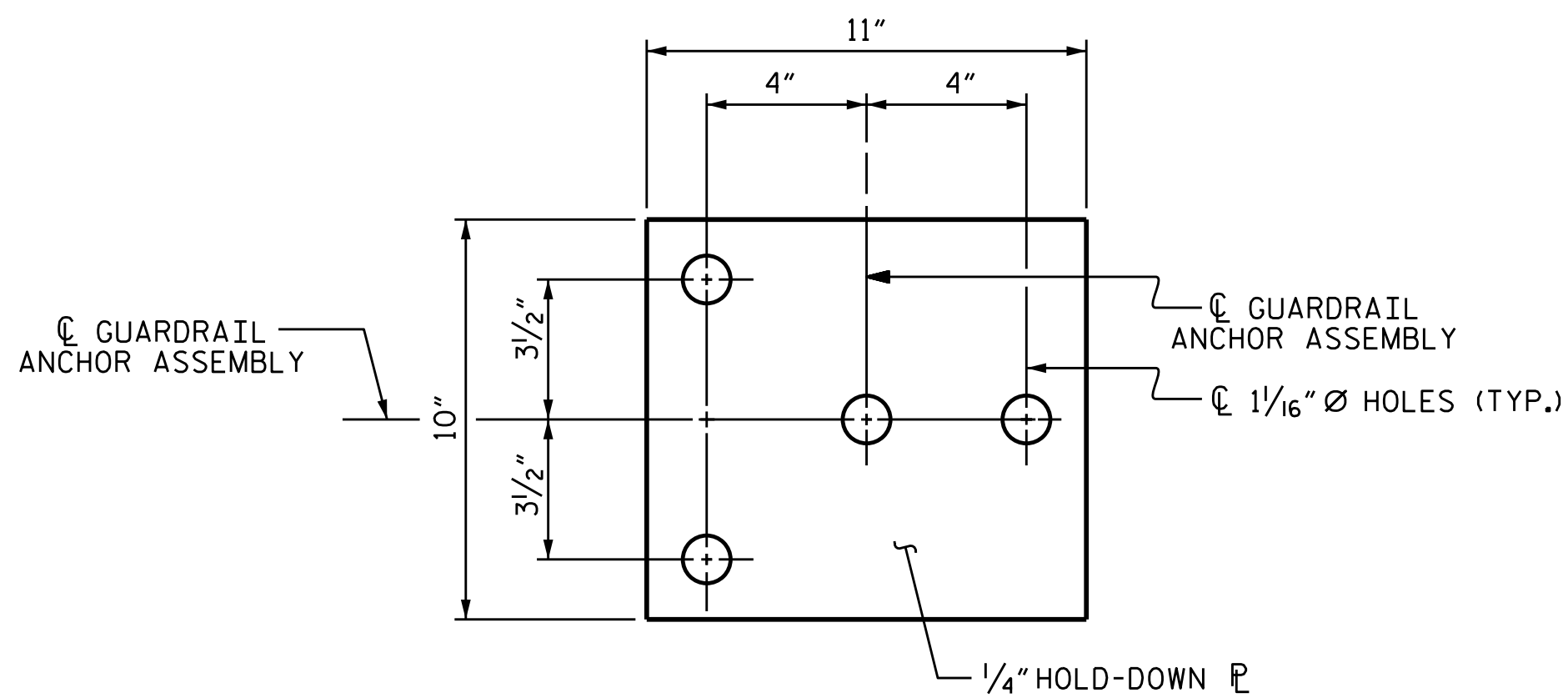

PLAN

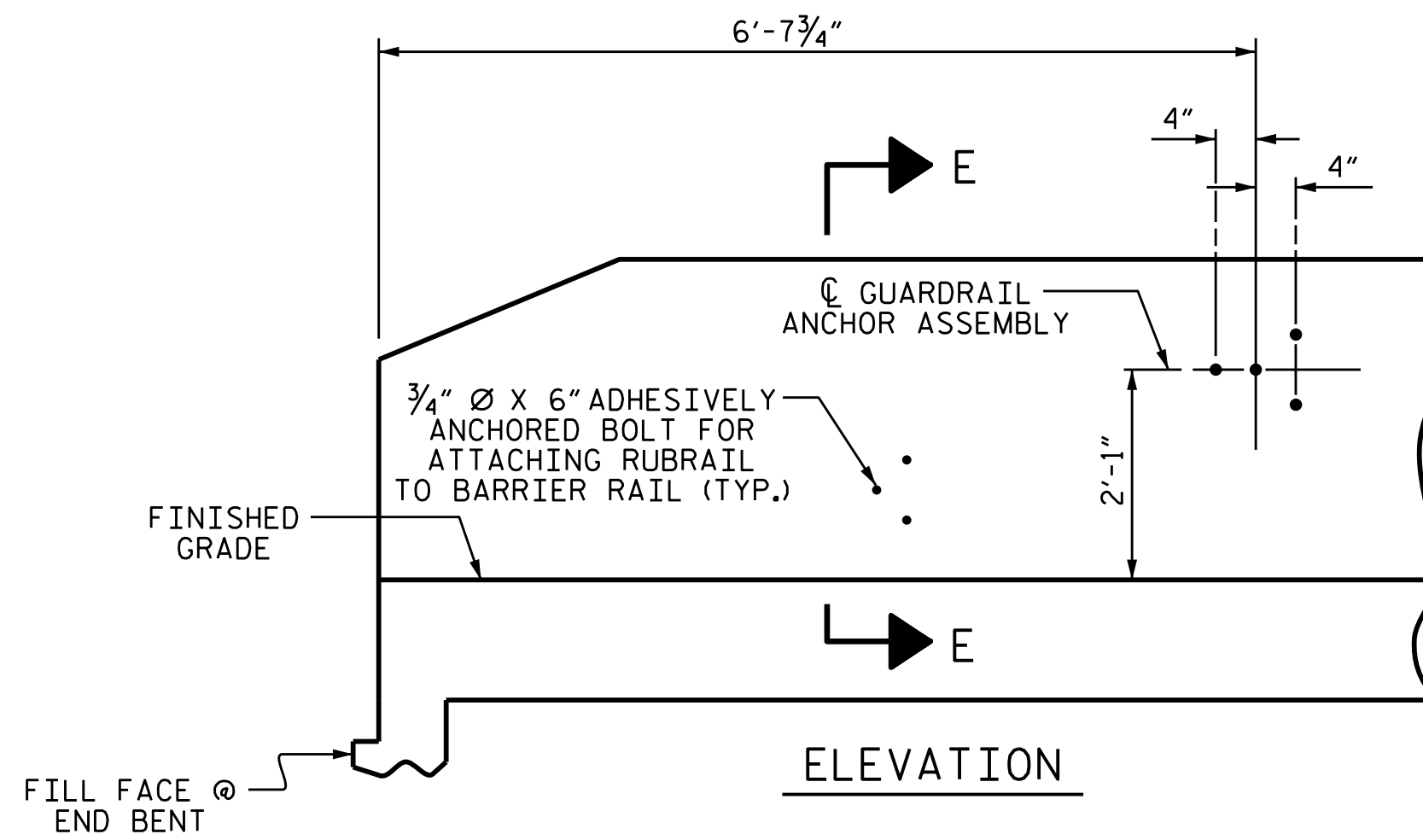

ELEVATION

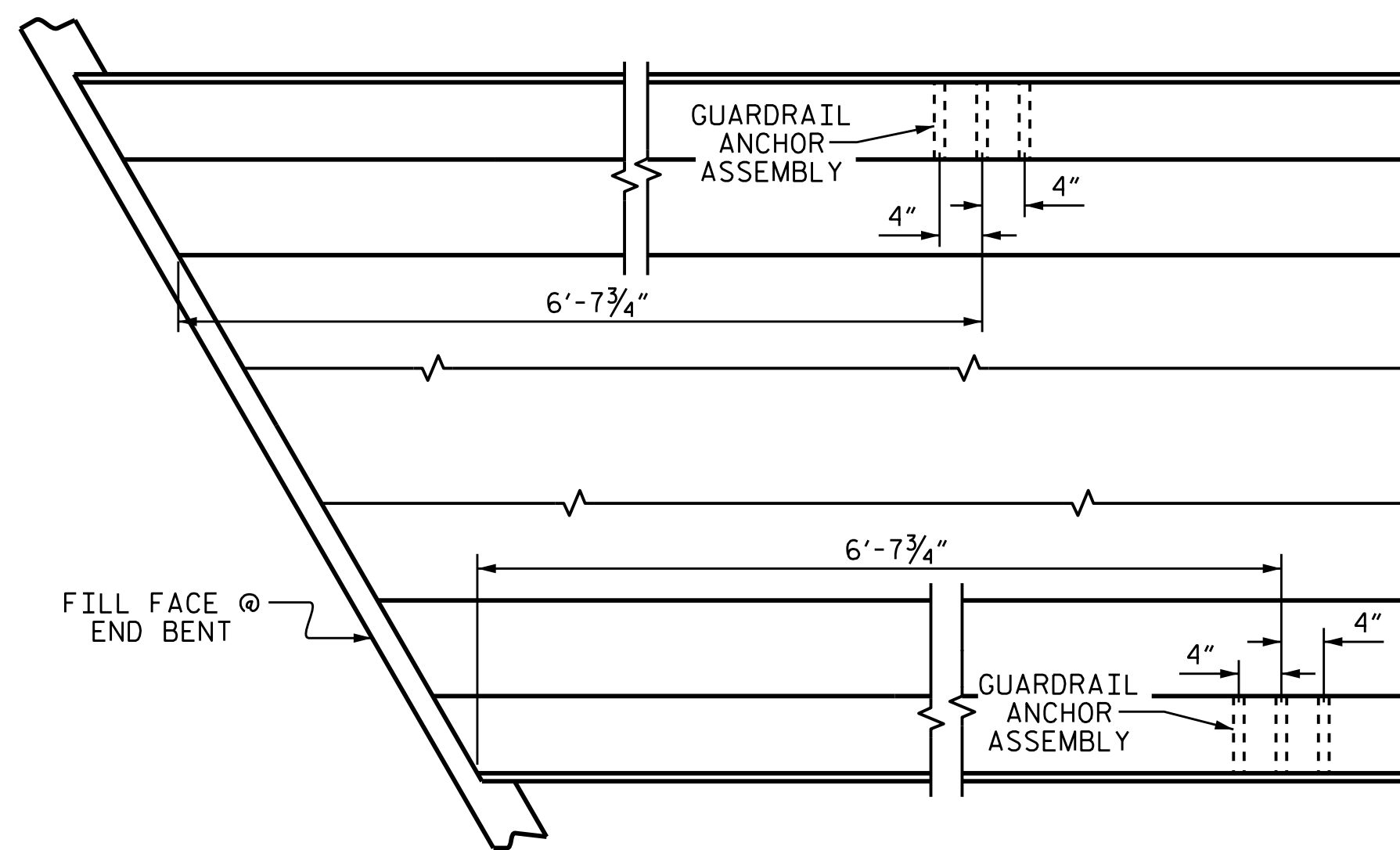

PLAN

LOCATION OF ANCHORS FOR GUARDRAIL

END BENT 1 SHOWN, END BENT 2 SIMILAR.

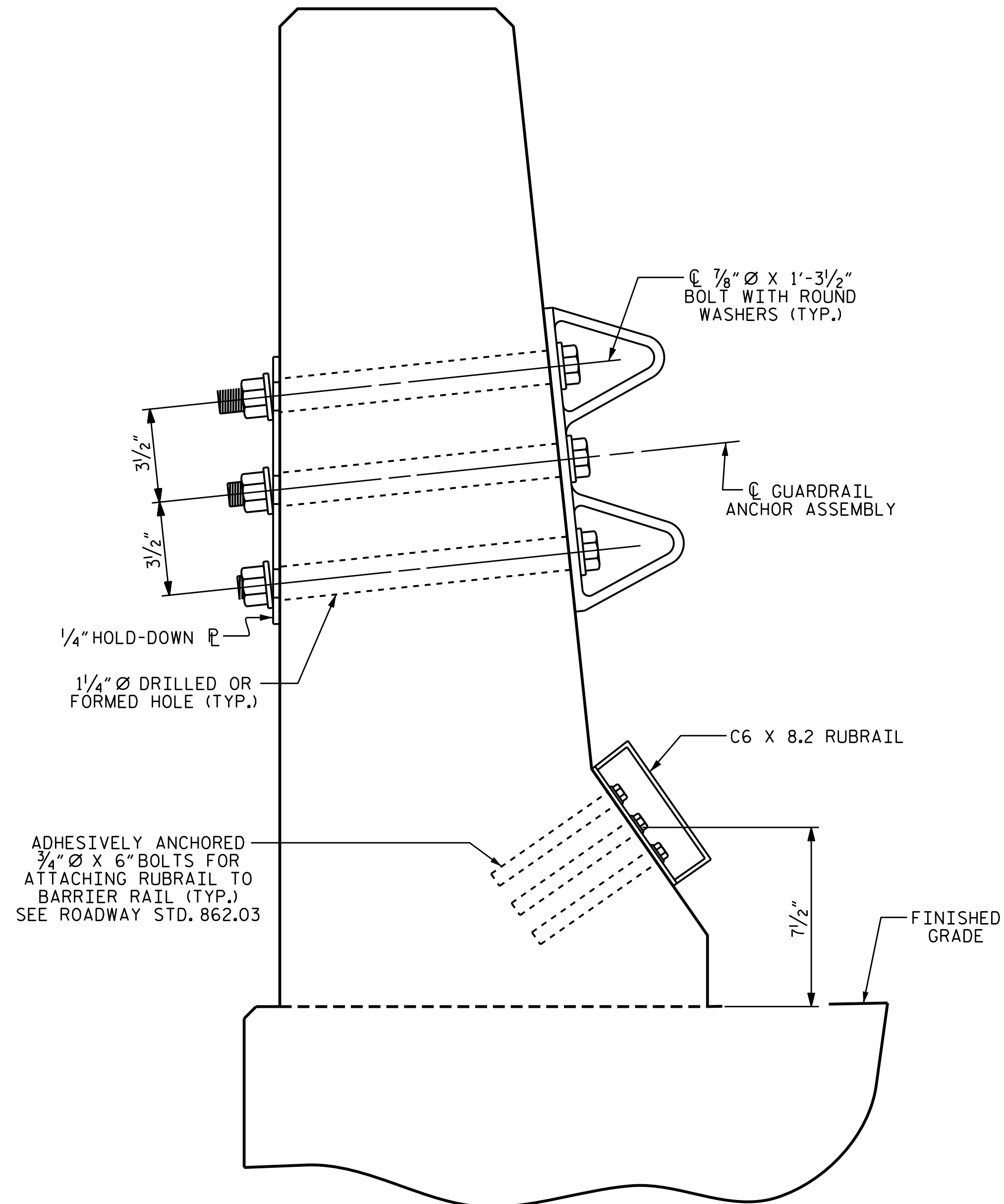

SECTION E-E

GUARDRAIL ANCHOR ASSEMBLY DETAILS

NOTES

THE GUARDRAIL ANCHOR ASSEMBLY SHALL CONSIST OF A 1/4" HOLD-DOWN PLATE AND 4 - 7/8" Ø BOLTS WITH NUTS AND WASHERS, RUBRAIL, AND ADHESIVELY ANCHORED BOLTS.

THE HOLD-DOWN PLATE SHALL CONFORM TO AASHTO M270 GRADE 36. AFTER FABRICATION, THE HOLD-DOWN PLATE SHALL BE HOT-DIP GALVANIZED IN ACCORDANCE WITH AASHTO M111.

BOLTS SHALL CONFORM TO THE REQUIREMENTS OF ASTM A307 AND NUTS SHALL CONFORM TO THE REQUIREMENTS OF AASHTO M291. BOLTS, NUTS AND WASHERS SHALL BE GALVANIZED. (AT THE CONTRACTOR'S OPTION, STAINLESS STEEL BOLTS, NUTS AND WASHERS MAY BE USED AS AN ALTERNATE FOR THE 7/8" Ø GALVANIZED BOLTS, NUTS AND WASHERS. THEY SHALL CONFORM TO OR EXCEED THE MECHANICAL REQUIREMENTS OF ASTM A307. THE USE OF THIS ALTERNATE SHALL BE APPROVED BY THE ENGINEER.)

THE GUARDRAIL ANCHOR ASSEMBLY IS REQUIRED AT ALL POINTS WHERE APPROACH GUARDRAIL IS TO BE ATTACHED TO THE END OF BARRIER RAIL. FOR POINTS OF ATTACHMENT, SEE SKETCH.

AFTER INSTALLATION, THE EXPOSED THREAD OF THE BOLT SHALL BE BURRED WITH A SHARP POINTED TOOL.

THE COST OF THE GUARDRAIL ANCHOR ASSEMBLY SHALL BE INCLUDED IN THE UNIT CONTRACT PRICE BID FOR CONCRETE BARRIER RAIL.

THE 1/4" Ø HOLES SHALL BE FORMED OR DRILLED WITH A CORE BIT. IMPACT TOOLS WILL NOT BE PERMITTED. ANY CONCRETE DAMAGED BY THIS WORK SHALL BE REPAIRED TO THE SATISFACTION OF THE ENGINEER.

THE C6 X 8.2 RUBRAIL IS TO BE ADHESIVELY ANCHORED TO THE RAIL USING THREE 3/4" Ø X 6" BOLTS WITH WASHERS. LEVEL ONE FIELD TESTING IS REQUIRED, AND THE YIELD LOAD OF THE 3/4" Ø BOLT IS 12 KIPS. FOR ADHESIVELY ANCHORED ANCHOR BOLTS OR DOWELS, SEE STANDARD SPECIFICATIONS. SEE ROADWAY STANDARD 862.03 FOR DETAILS AND LOCATION OF THE RUBRAIL.

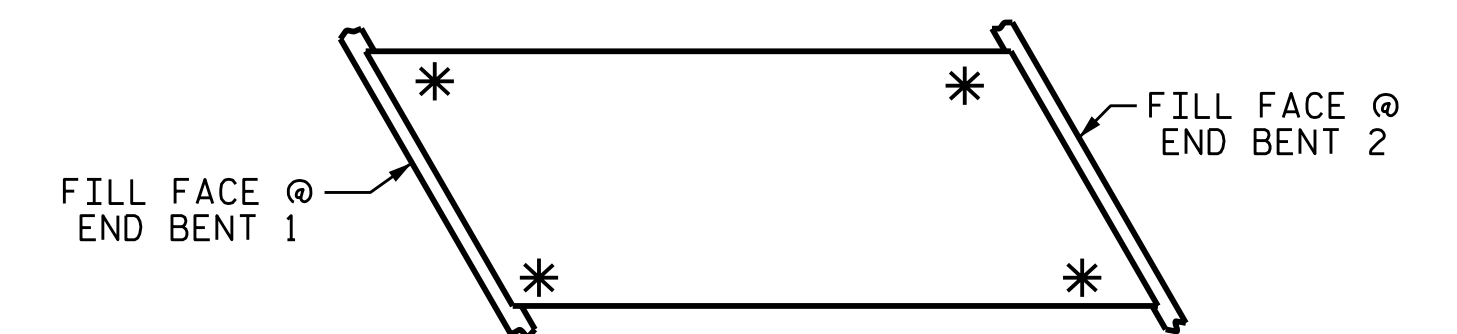

SKETCH SHOWING POINTS OF ATTACHMENTS

* DENOTES GUARDRAIL ANCHOR ASSEMBLY

PROJECT NO. U-2579C
 FORSYTH COUNTY
 STATION: 473+70.00 -L-

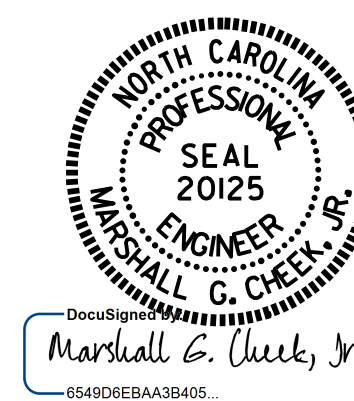

STATE OF NORTH CAROLINA
 DEPARTMENT OF TRANSPORTATION
 RALEIGH
 STANDARD
 GUARDRAIL ANCHORAGE
 FOR BARRIER RAIL
 (LEFT LANE)

ASSEMBLED BY : J. K. BOWLES	DATE : 2/23/16
CHECKED BY : N. D'AIUTO	DATE : 3/17/16
DRAWN BY : TLA 5/06	REV. 10/1/11 MAA/GM
CHECKED BY : GM 5/06	REV. 7/12 MAA/GM
	REV. 6/13 MAA/GM

DOCUMENT NOT CONSIDERED FINAL UNLESS ALL SIGNATURES COMPLETED

REVISIONS						SHEET NO.
NO.	BY:	DATE:	NO.	BY:	DATE:	S3-19
1			3			TOTAL SHEETS 33
2			4			

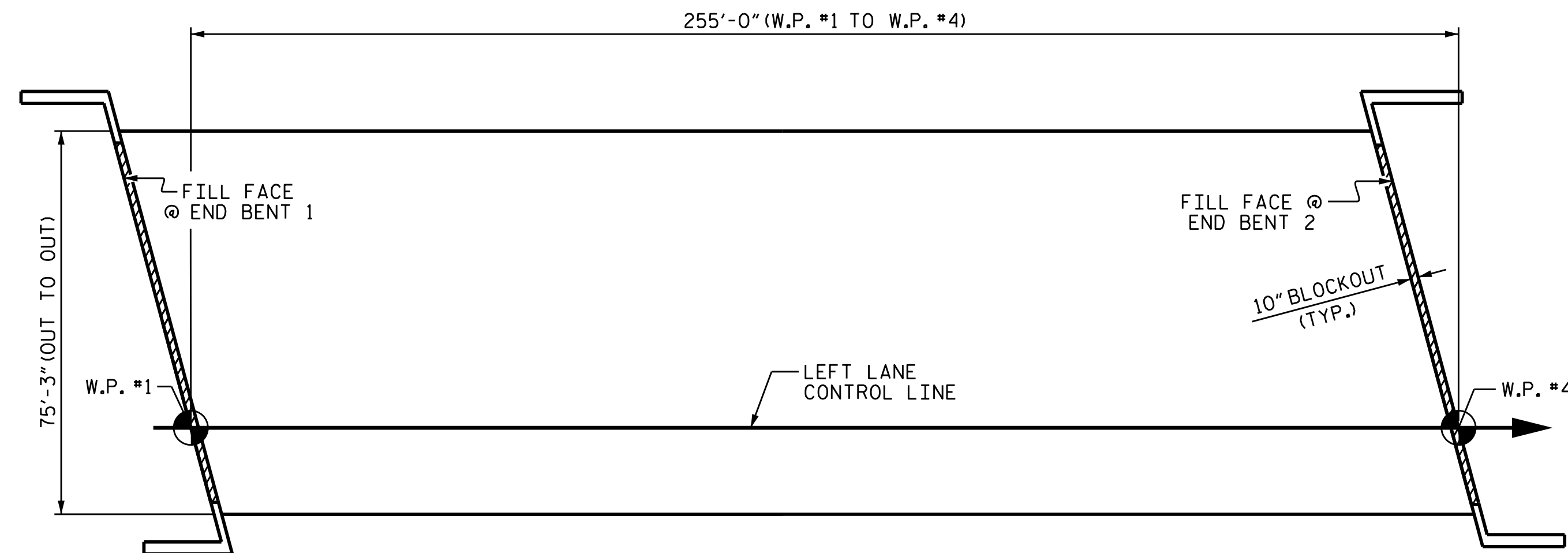

LAYOUT FOR COMPUTING AREA OF REINFORCED CONCRETE DECK SLAB (SQ. FT. 19,189)

BAR TYPE						BILL OF MATERIAL					
BAR NO.	NO.	SIZE	TYPE	LENGTH	WEIGHT	BAR NO.	NO.	SIZE	TYPE	LENGTH	WEIGHT
*A1	860	#5	STR	38'-9"	34758	*B1	10	#5	STR	52'-7"	548
A2	860	#5	STR	38'-7"	34608	*B2	197	#5	STR	13'-0"	2671
*A101	8	#5	STR	37'-1"	309	*B3	100	#4	STR	16'-6"	1102
*A102	8	#5	STR	35'-1"	293	*B4	99	#5	STR	58'-0"	5989
*A103	8	#5	STR	33'-1"	276	*B5	98	#5	STR	24'-0"	2453
*A104	4	#5	STR	59'-5"	248	*B6	100	#4	STR	17'-0"	1136
*A105	4	#5	STR	55'-5"	231	*B7	198	#5	STR	34'-9"	7176
*A106	4	#5	STR	51'-4"	214	*B8	98	#5	STR	28'-6"	2913
*A107	4	#5	STR	47'-4"	197	*B9	100	#4	STR	23'-9"	1587
*A108	4	#5	STR	43'-3"	180	*B10	197	#5	STR	19'-0"	3904
*A109	4	#5	STR	39'-3"	164	B11	400	#5	STR	52'-4"	21833
*A110	4	#5	STR	35'-2"	147	K1	30	#4	STR	26'-5"	529
*A111	4	#5	STR	31'-2"	130	K2	16	#4	STR	6'-2"	66
*A112	4	#5	STR	27'-1"	113	K3	96	#4	STR	6'-8"	428
*A113	4	#5	STR	23'-1"	96	K4	96	#4	STR	7'-9"	497
*A114	4	#5	STR	19'-0"	79	K5	32	#4	STR	5'-0"	107
*A115	4	#5	STR	15'-0"	63	K6	20	#4	5	5'-4"	71
*A116	4	#5	STR	10'-11"	46	K7	70	#4	6	10'-8"	499
*A117	4	#5	STR	6'-11"	29	K8	4	#4	STR	2'-3"	6
*A118	4	#5	STR	2'-10"	12	K9	8	#4	STR	2'-6"	13
						K10	8	#4	STR	3'-0"	16
A201	8	#5	STR	36'-11"	308						
A202	8	#5	STR	34'-11"	291	S1	416	#4	1	2'-9"	764
A203	8	#5	STR	32'-11"	275	S2	120	#4	2	11'-5"	915
A204	4	#5	STR	59'-5"	248	*S3	120	#4	3	11'-11"	955
A205	4	#5	STR	55'-5"	231	*S4	120	#4	3	11'-1"	888
A206	4	#5	STR	51'-4"	214						
A207	4	#5	STR	47'-4"	197	U1	80	#4	4	12'-7"	672
A208	4	#5	STR	43'-3"	180	U2	32	#4	4	10'-7"	226
A209	4	#5	STR	39'-3"	164	REINFORCING STEEL LBS.					64,073
A210	4	#5	STR	35'-2"	147	* EPOXY COATED REINFORCING STEEL LBS.					68,907
A211	4	#5	STR	31'-2"	130						
A212	4	#5	STR	27'-1"	113						
A213	4	#5	STR	23'-1"	96						
A214	4	#5	STR	19'-0"	79						
A215	4	#5	STR	15'-0"	63						
A216	4	#5	STR	10'-11"	46						
A217	4	#5	STR	6'-11"	29						
A218	4	#5	STR	2'-10"	12						

ALL BAR DIMENSIONS ARE OUT TO OUT.

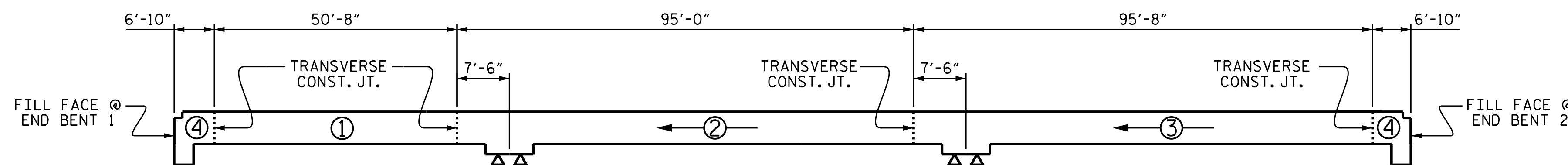

DECK POURING SEQUENCE

④ = INDICATES THE NUMBER AND DIRECTION OF POUR.

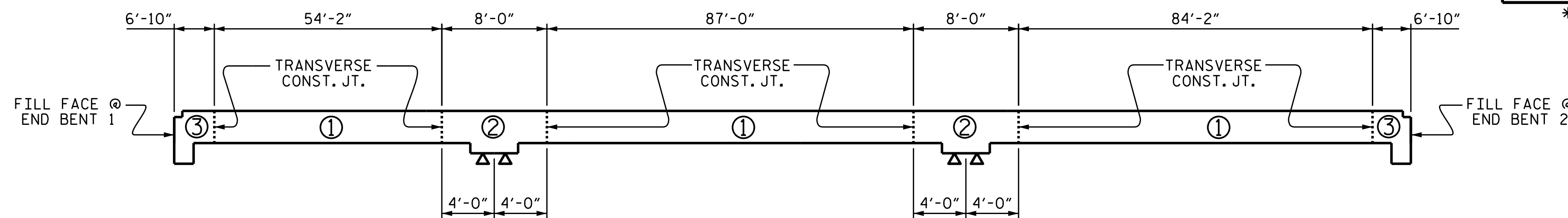

OPTIONAL DECK POURING DETAIL

POURS ② AND ③ SHALL NOT BE STARTED UNTIL BOTH ADJACENT POUR ① REACH A MINIMUM OF 3000 PSI

GROOVING BRIDGE FLOORS

APPROACH SLABS	3,331	SO. FT.
BRIDGE DECK	17,452	SO. FT.
TOTAL	20,783	SO. FT.

SUPERSTRUCTURE BILL OF MATERIAL

	CLASS AA CONCRETE (C.Y.)	REINFORCING STEEL (LBS.)	EPOXY COATED REINFORCING STEEL (LBS.)
POUR #1	118.1	64,073	68,907
POUR #2	248.3		
POUR #3	249.5		
POUR #4	107.1		
TOTAL **	723.0	64,073	68,907

** QUANTITIES FOR CONCRETE BARRIER RAIL ARE NOT INCLUDED

SUPERSTRUCTURE REINFORCING STEEL LENGTHS ARE BASED ON THE FOLLOWING MINIMUM SPLICE LENGTHS

BAR SIZE	SUPERSTRUCTURE EXCEPT APPROACH SLABS, PARAPET, AND BARRIER RAIL		APPROACH SLABS		PARAPET AND BARRIER RAIL
	EPOXY COATED	UNCOATED	EPOXY COATED	UNCOATED	
#4	2'-0"	1'-9"	2'-0"	1'-9"	2'-9"
#5	2'-6"	2'-2"	2'-6"	2'-2"	3'-5"
#6	3'-0"	2'-7"	3'-10"	2'-7"	4'-4"
#7	5'-3"	3'-6"			
#8	6'-10"	4'-7"			

PROJECT NO. U-2579C
 FORSYTH COUNTY
 STATION: 473+70.00 -L-

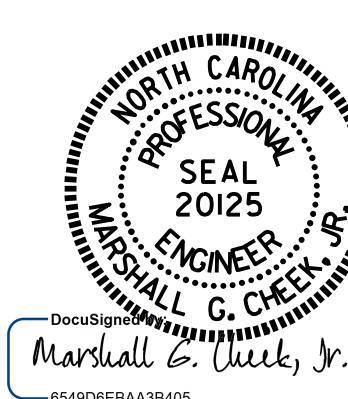

7/27/2017

STATE OF NORTH CAROLINA
 DEPARTMENT OF TRANSPORTATION
 RALEIGH
 SUPERSTRUCTURE
 BILL OF MATERIAL
 (LEFT LANE)

DRAWN BY: J. K. BOWLES DATE: 1/29/16
 CHECKED BY: N. D'AIUTO DATE: 3/17/16
 DESIGN ENGINEER OF RECORD: H. A. LOCKLEAR DATE: 3/17/16

26-JUL-2017 15:07
 R:\Structures\FINAL PLANS\403_U-2579C_SMU.BM.020_330702.dgn
 mcheek

DOCUMENT NOT CONSIDERED FINAL UNLESS ALL SIGNATURES COMPLETED

REVISIONS			SHEET NO.		
NO.	BY:	DATE:	NO.	BY:	DATE:
1			3		
2			4		

TOTAL SHEETS: 33

STR. #3

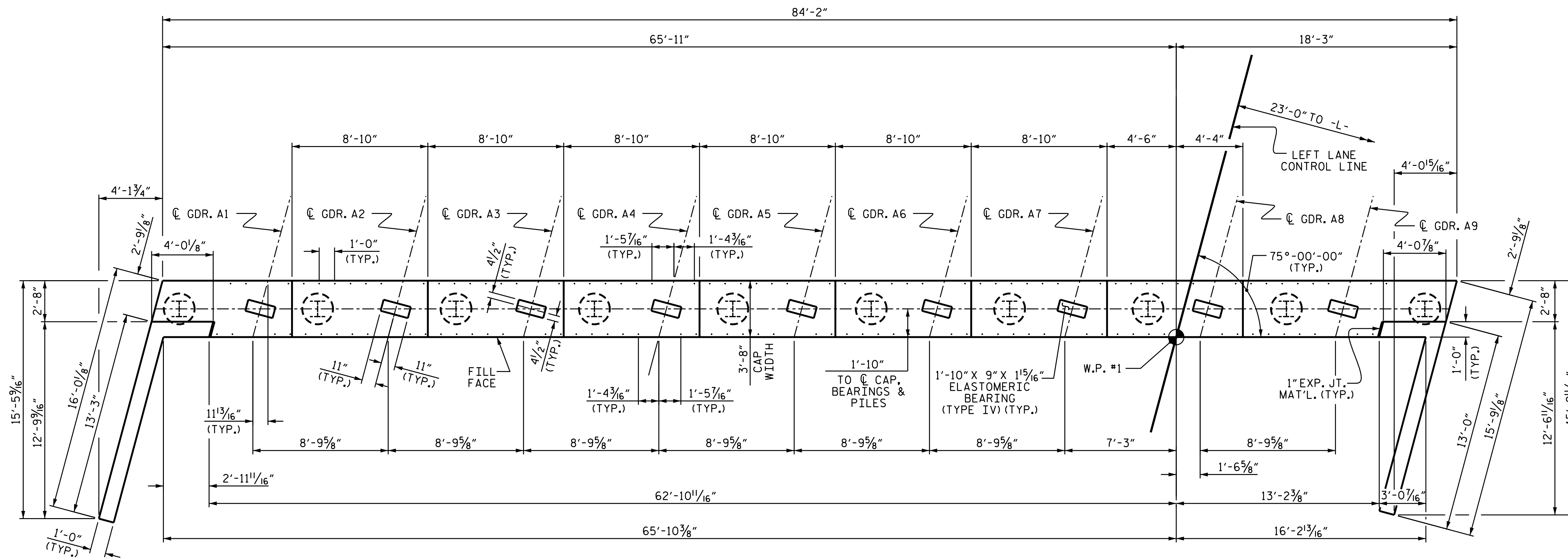

NOTES

THE TOP SURFACE OF THE END BENT CAP, EXCEPT THE BEARING AREA, SHALL BE RAKED TO A DEPTH OF 1/4".

TOP OF PILE ELEVATIONS	
①	876.87
②	877.00
③	877.14
④	877.27
⑤	877.40
⑥	877.53
⑦	877.66
⑧	877.79
⑨	877.93
⑩	878.06

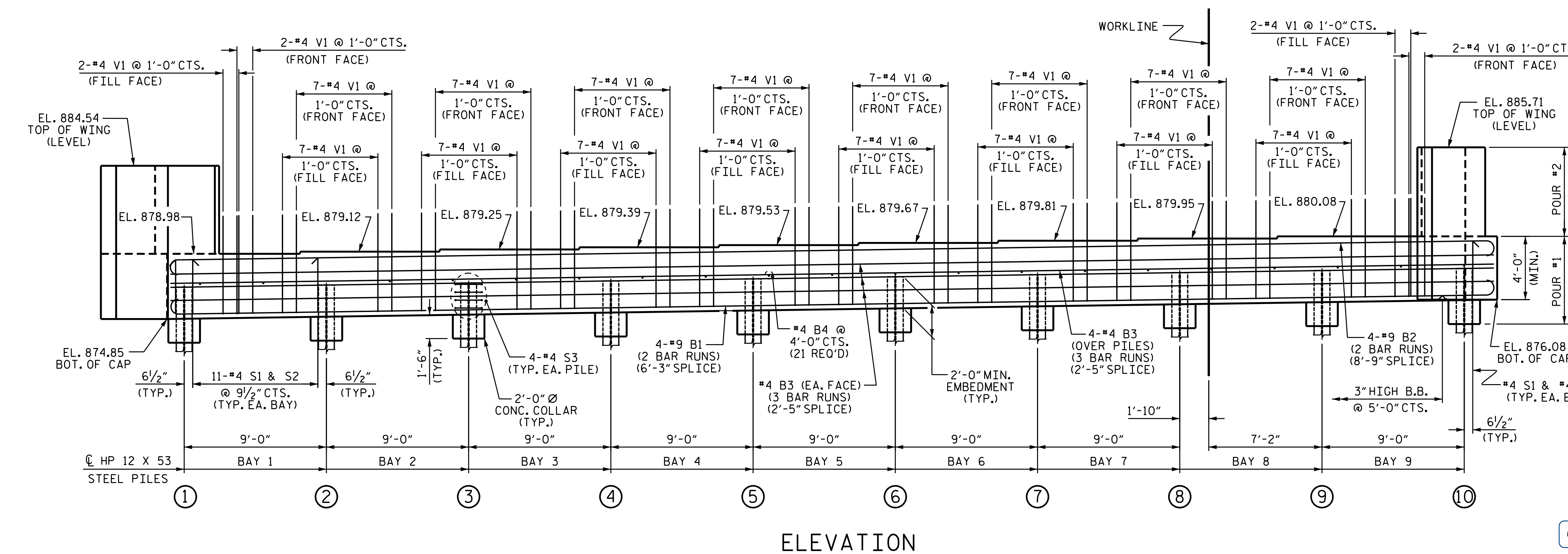

PROJECT NO. U-2579C
 FORSYTH COUNTY
 STATION: 473+70.00 -L-

SHEET 1 OF 3

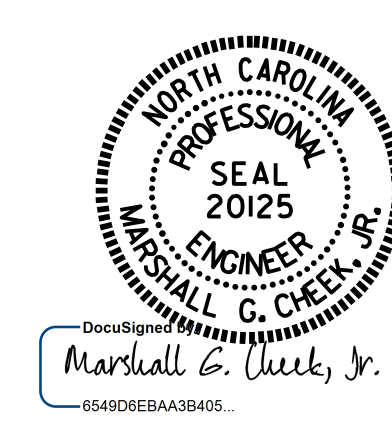

STATE OF NORTH CAROLINA
 DEPARTMENT OF TRANSPORTATION
 RALEIGH

**SUBSTRUCTURE
 INTEGRAL
 END BENT 1
 (LEFT LANE)**

DRAWN BY : H.A. LOCKLEAR DATE : 6/15/16
 CHECKED BY : K.D. LAYNE DATE : 8/3/16
 DESIGN ENGINEER OF RECORD : H.A. LOCKLEAR DATE : 8/18/16

DOCUMENT NOT CONSIDERED
 FINAL UNLESS ALL
 SIGNATURES COMPLETED

REVISIONS				SHEET NO.	
NO.	BY:	DATE:	NO.	BY:	DATE:
1			3		
2			4		

S3-21
 TOTAL SHEETS
 33

7/27/2017

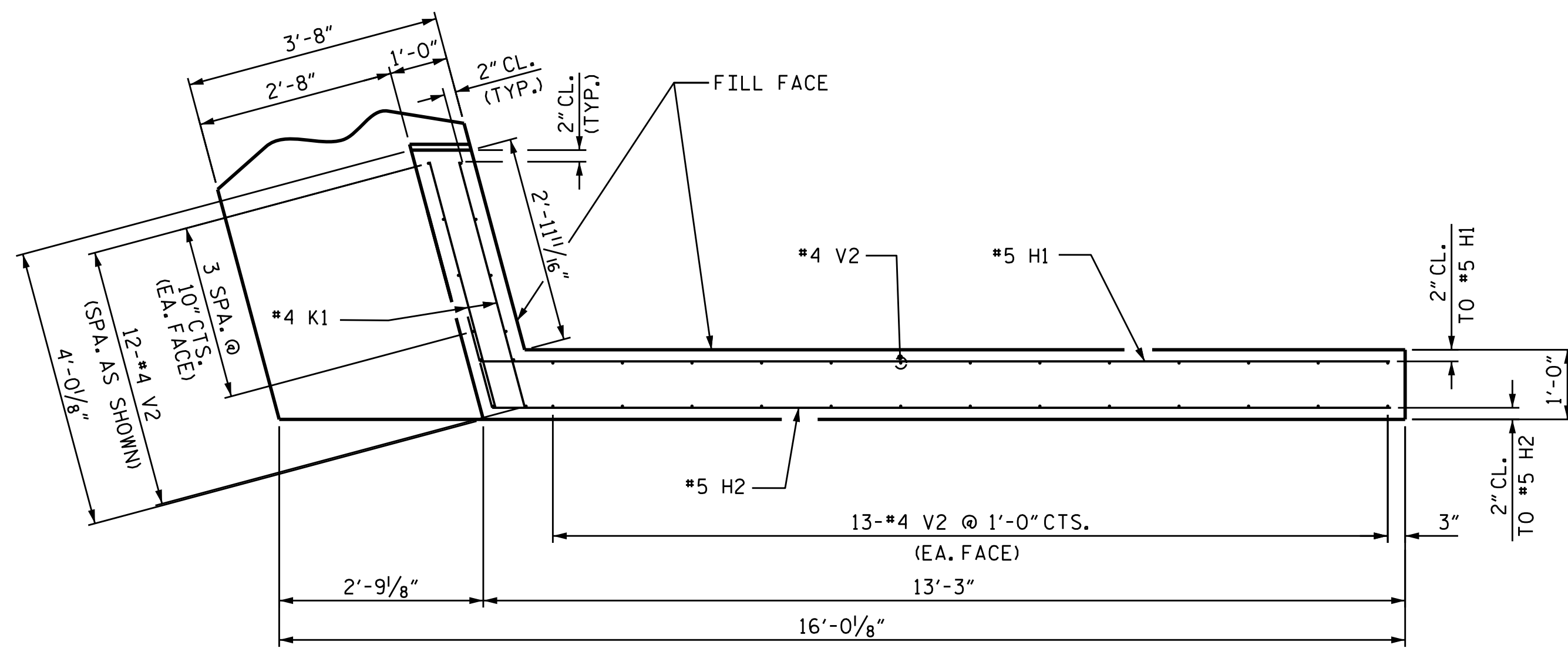

PLAN OF LEFT WING

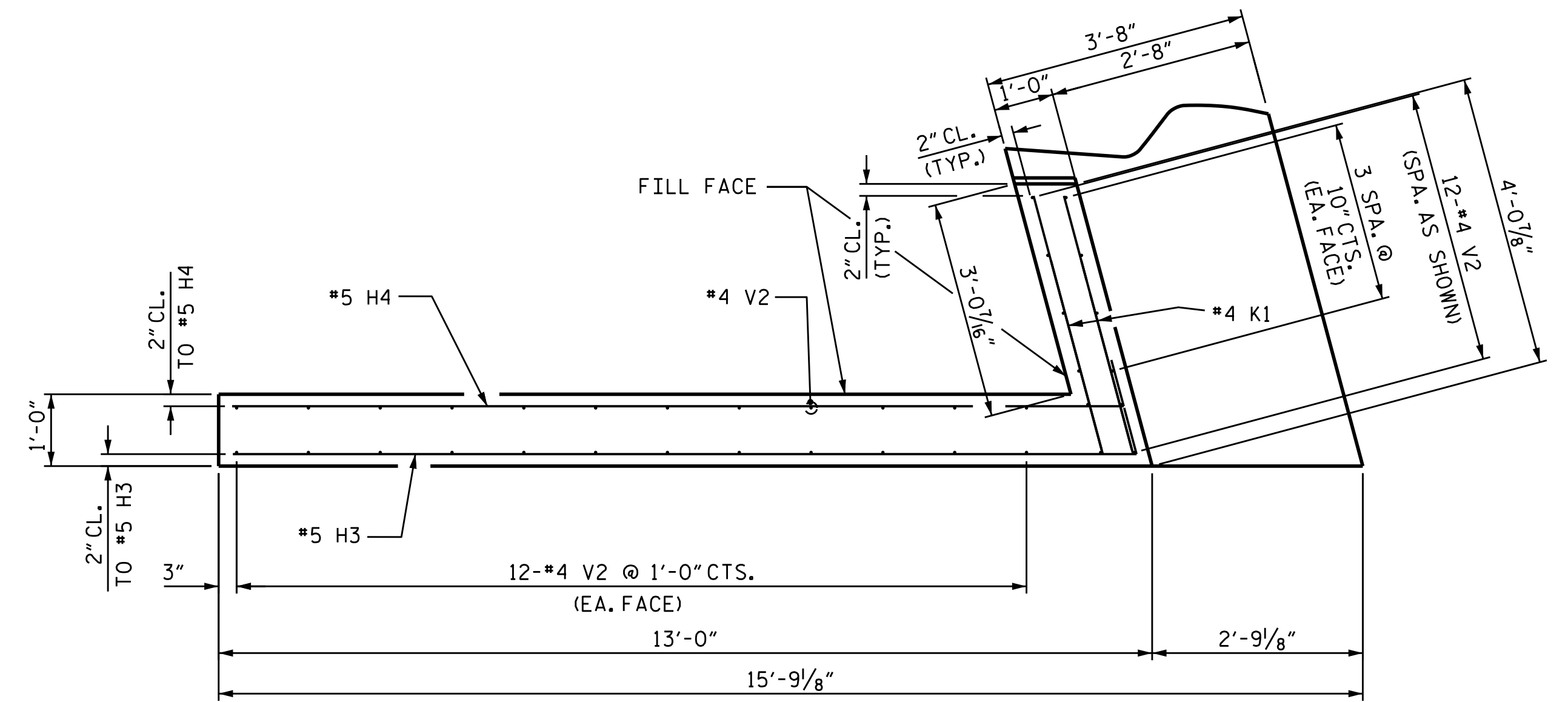

PLAN OF RIGHT WING

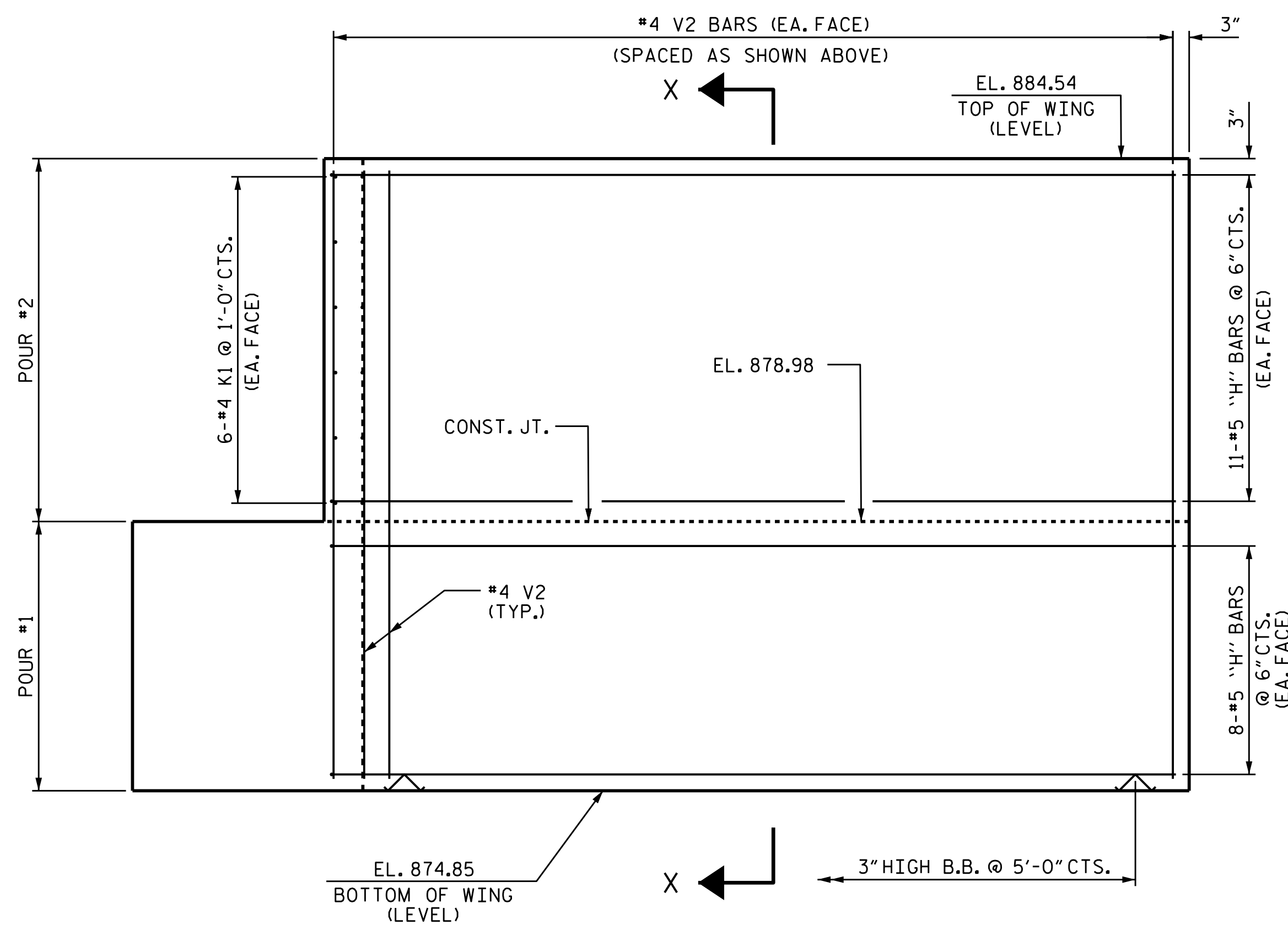

ELEVATION OF LEFT WING

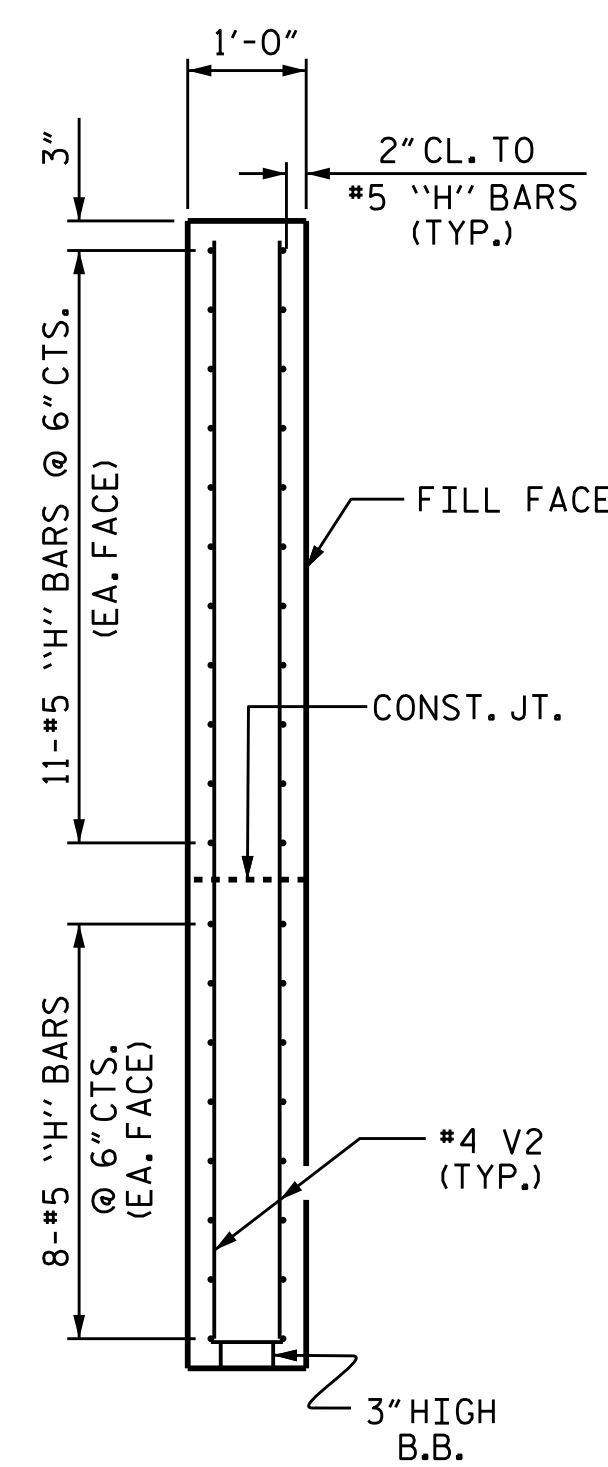

SECTION X-X

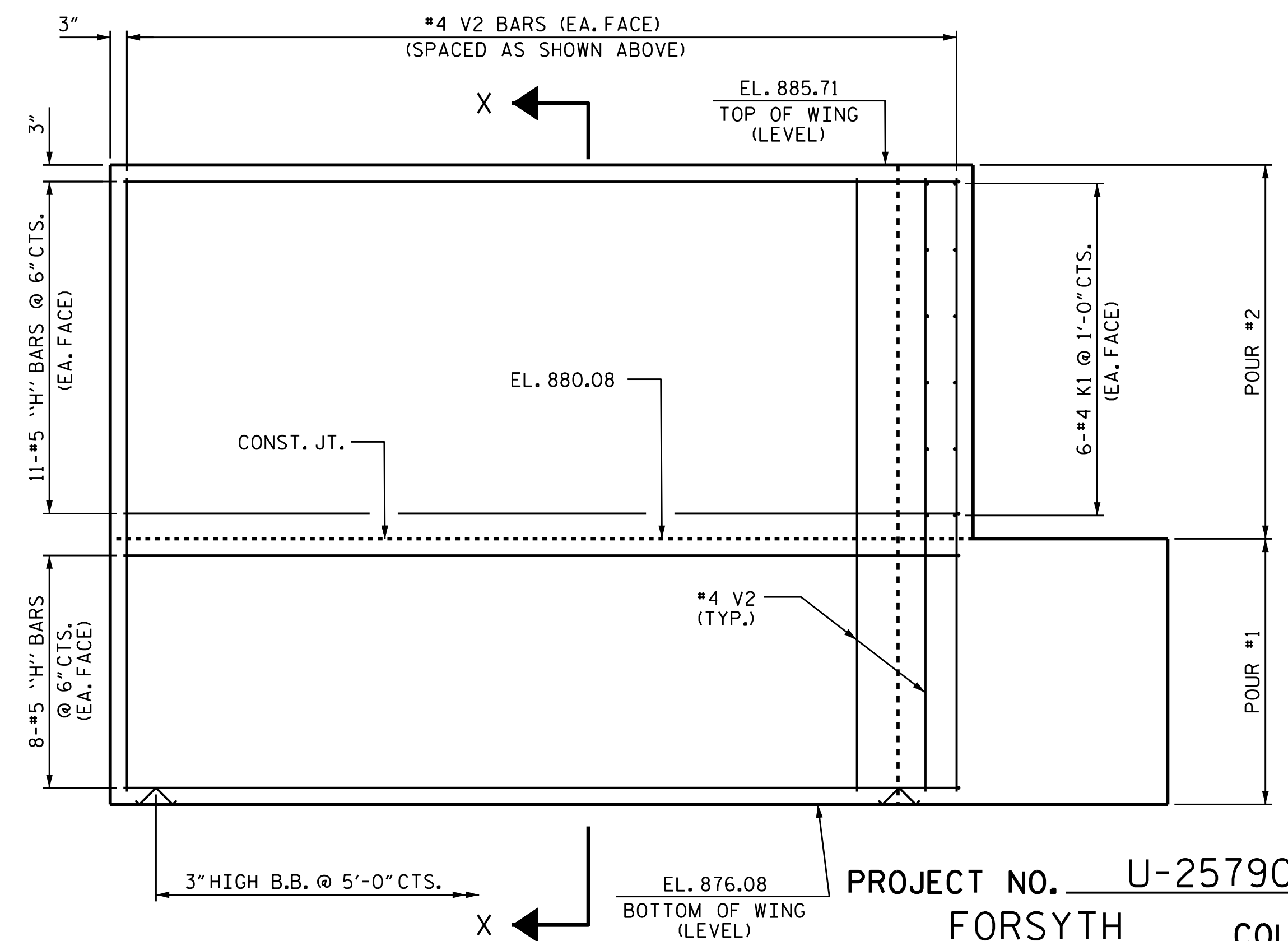

ELEVATION OF RIGHT WING

PROJECT NO. U-2579C
 FORSYTH COUNTY
 STATION: 473+70.00 -L-

SHEET 2 OF 3

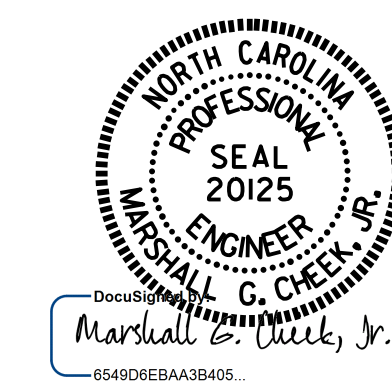

STATE OF NORTH CAROLINA
 DEPARTMENT OF TRANSPORTATION
 RALEIGH
 SUBSTRUCTURE
 INTEGRAL
 END BENT 1
 (LEFT LANE)

DRAWN BY : H.A. LOCKLEAR DATE : 6/22/16
 CHECKED BY : K.D. LAYNE DATE : 8/3/16
 DESIGN ENGINEER OF RECORD : H.A. LOCKLEAR DATE : 8/18/16

DOCUMENT NOT CONSIDERED
 FINAL UNLESS ALL
 SIGNATURES COMPLETED

REVISIONS						SHEET NO.	
NO.	BY:	DATE:	NO.	BY:	DATE:	S3-22	
1			3			TOTAL SHEETS	
2			4			33	

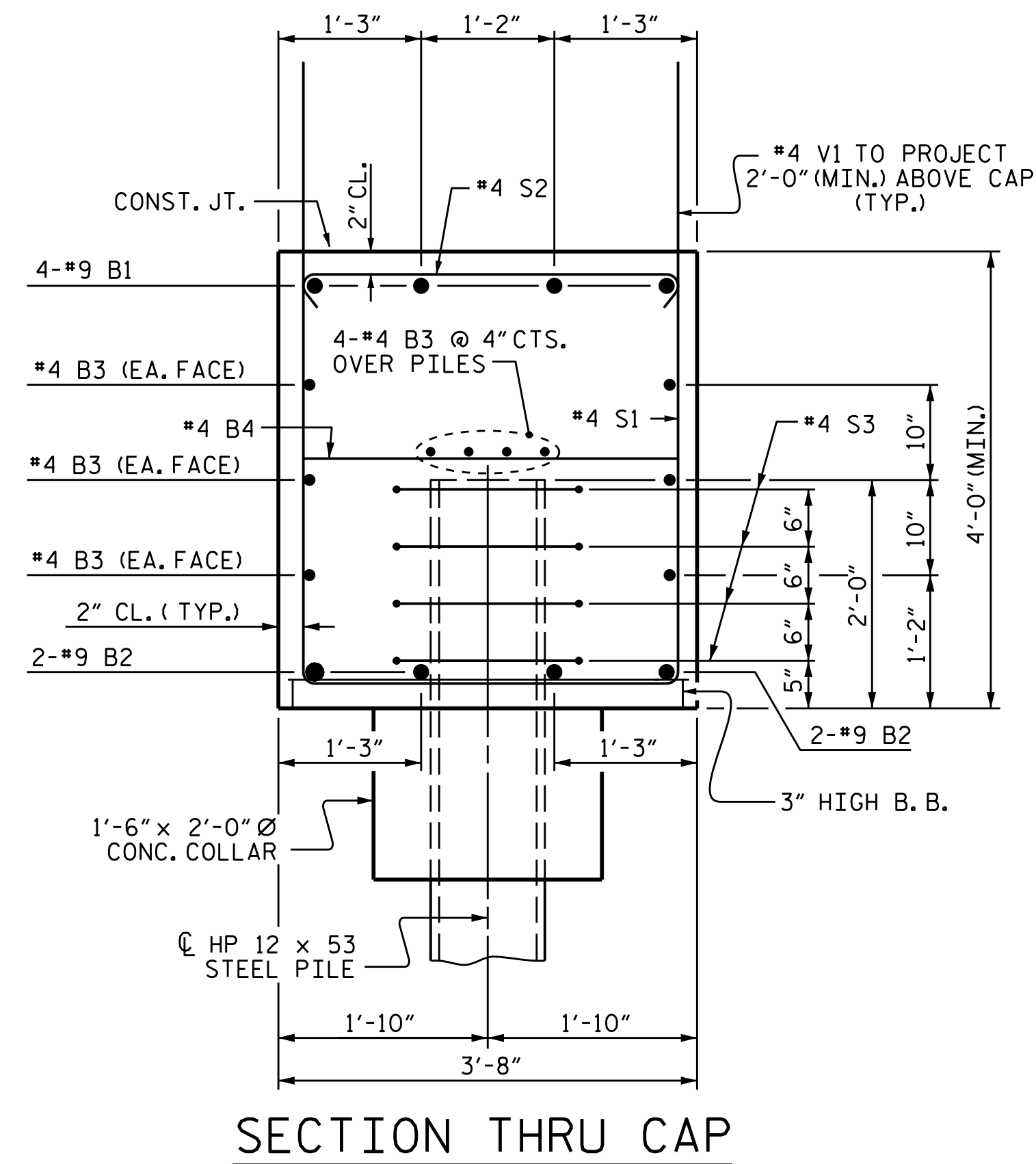

BAR TYPES

ALL BAR DIMENSIONS ARE OUT TO OUT.

BILL OF MATERIAL					
INTEGRAL END BENT 1					
BAR NO.	NO.	SIZE	TYPE	LENGTH	WEIGHT
B1	8	#9	1	47'-7"	1294
B2	8	#9	1	46'-4"	1260
B3	30	#4	STR	29'-7"	593
B4	21	#4	STR	3'-4"	47
H1	19	#5	2	13'-9"	272
H2	19	#5	2	13'-7"	269
H3	19	#5	3	13'-3"	263
H4	19	#5	3	13'-1"	259
K1	24	#4	STR	3'-8"	59
S1	101	#4	4	11'-4"	765
S2	101	#4	5	4'-1"	267
S3	40	#4	6	6'-6"	174
V1	120	#4	STR	6'-0"	481
V2	74	#4	STR	9'-3"	457
REINFORCING STEEL				LBS.	6,468
CLASS A CONCRETE					
POUR #1 CAP, LOWER WINGS & CONC. COLLARS				C.Y.	52.3
POUR #2 UPPER PART OF WINGS				C.Y.	6.7
TOTAL CLASS A CONCRETE				C.Y.	59.0
HP 12 X 53 STEEL PILES				NO.:	10
				LIN. FT.	675
PILE DRIVING EQUIPMENT SETUP FOR HP 12 X 53 STEEL PILES				EACH	10

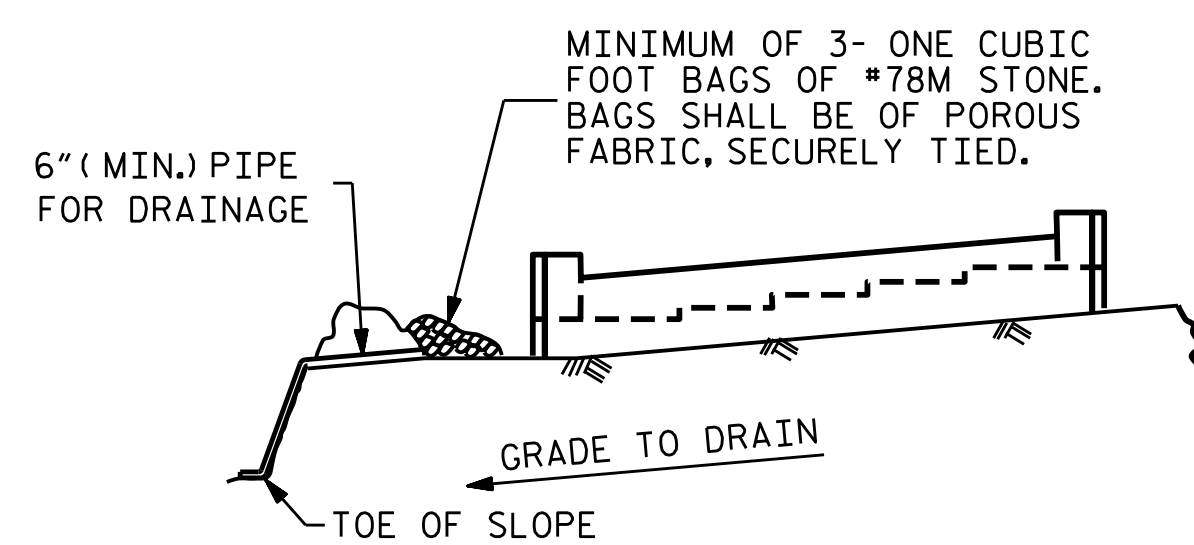
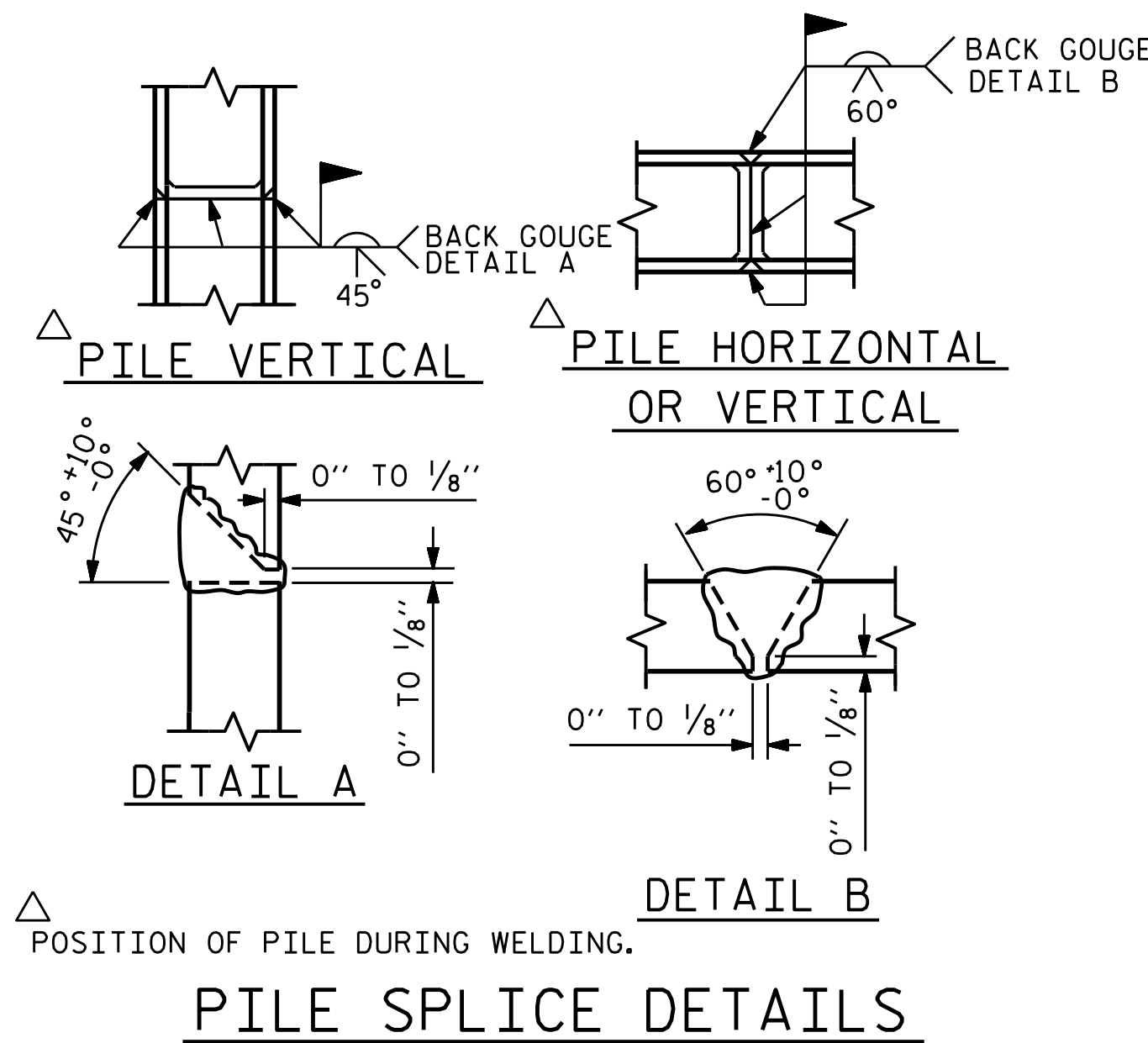

BAGGED STONE AND PIPE SHALL BE PLACED IMMEDIATELY AFTER COMPLETION OF END BENT EXCAVATION. PIPE MAY BE EITHER CONCRETE, CORRUGATED STEEL, CORRUGATED ALUMINUM ALLOY, OR CORRUGATED PLASTIC. PERFORATED PIPE WILL NOT BE ALLOWED.

BAGGED STONE SHALL REMAIN IN PLACE UNTIL THE ENGINEER DIRECTS THAT IT BE REMOVED. THE CONTRACTOR SHALL REMOVE AND DISPOSE OF SILT ACCUMULATIONS AT BAGGED STONE WHEN SO DIRECTED BY THE ENGINEER. BAGS SHALL BE REMOVED AND REPLACED WHENEVER THE ENGINEER DETERMINES THAT THEY HAVE DETERIORATED AND LOST THEIR EFFECTIVENESS.

NO SEPARATE PAYMENT WILL BE MADE FOR THIS WORK AND THE ENTIRE COST OF THIS WORK SHALL BE INCLUDED IN THE UNIT CONTRACT PRICE BID FOR THE SEVERAL PAY ITEMS.

PROJECT NO. U-2579C
FORSYTH COUNTY
 STATION: 473+70.00 -L-

SHEET 3 OF 3

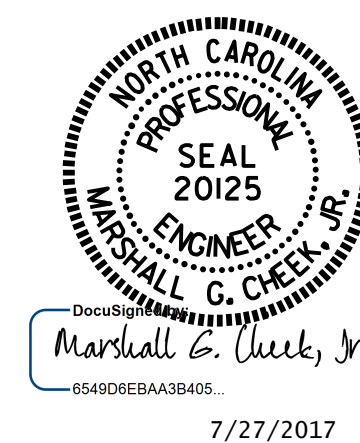

STATE OF NORTH CAROLINA
 DEPARTMENT OF TRANSPORTATION
 RALEIGH

SUBSTRUCTURE
 INTEGRAL
 END BENT 1
 (LEFT LANE)

REVISIONS

NO.	BY:	DATE:	NO.	BY:	DATE:
1			3		
2			4		

SHEET NO.
S3-23
 TOTAL SHEETS
33

DOCUMENT NOT CONSIDERED FINAL UNLESS ALL SIGNATURES COMPLETED

DRAWN BY: H.A. LOCKLEAR DATE: 6/23/16
 CHECKED BY: K.D. LAYNE DATE: 8/3/16
 DESIGN ENGINEER OF RECORD: H.A. LOCKLEAR DATE: 8/18/16

NOTES

ALL STEEL IN THE DRILLED PIERS IS INCLUDED IN THE PAY ITEMS FOR "REINFORCING STEEL" AND "SPIRAL COLUMN REINFORCING STEEL".

THE CONTRACTOR'S ATTENTION IS CALLED TO THE FACT THAT THE LONGITUDINAL REINFORCEMENT FOR THE DRILLED PIERS IS DETAILED WITH 3 FEET OF EXTRA LENGTH.

THE LOCATION OF THE CONSTRUCTION JOINT IN THE DRILLED PIERS IS BASED ON AN APPROXIMATE GROUND LINE ELEVATION. IF THE CONSTRUCTION JOINT IS ABOVE THE ACTUAL GROUND LINE ELEVATION, THE CONTRACTOR SHALL PLACE THE CONSTRUCTION JOINT 1 FT. BELOW THE GROUND LINE.

STIRRUPS IN CAP MAY BE SHIFTED AS NECESSARY TO CLEAR ANCHOR BOLTS.

HOOKS ON "V" BARS MAY BE TURNED AS NECESSARY FOR PLACING REINFORCING STEEL.

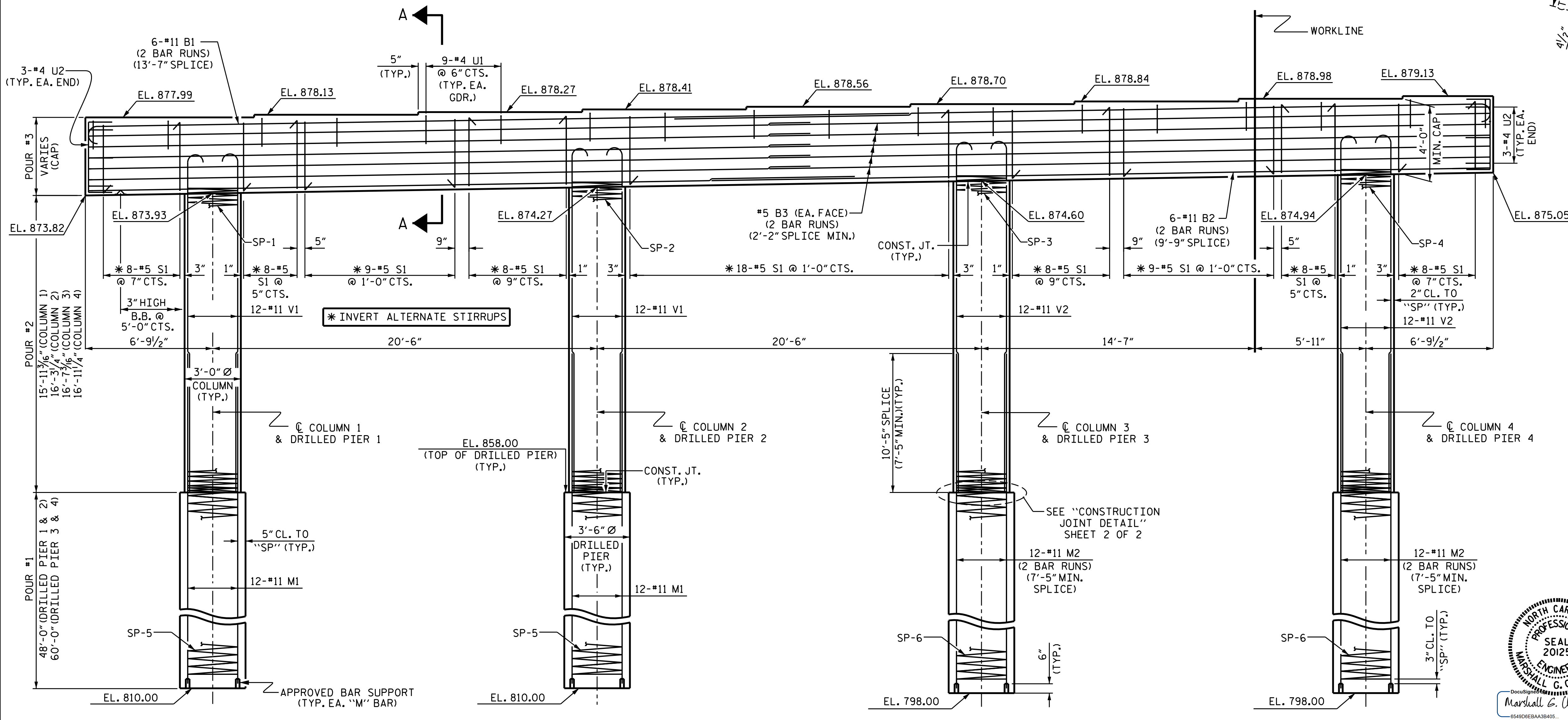
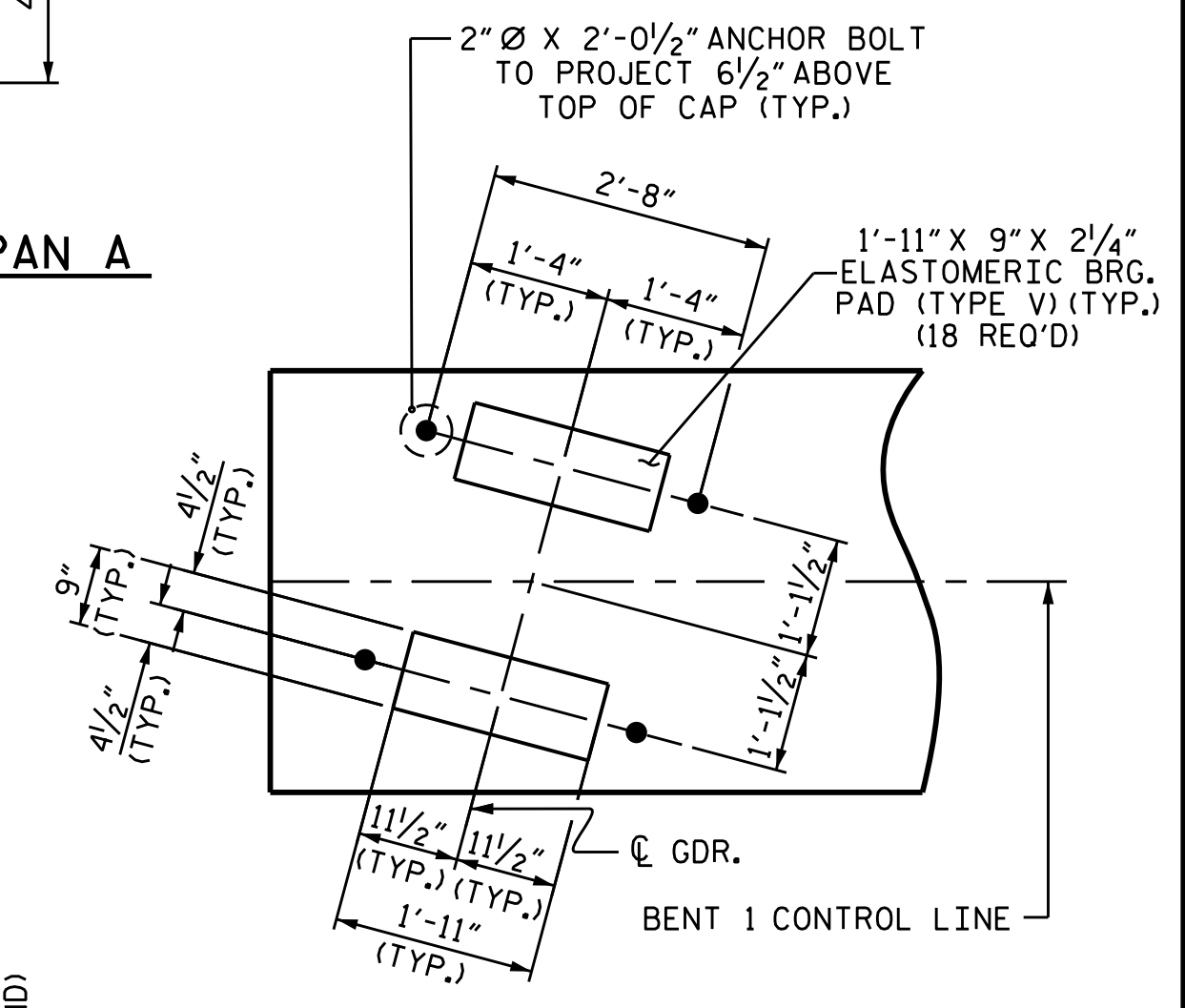
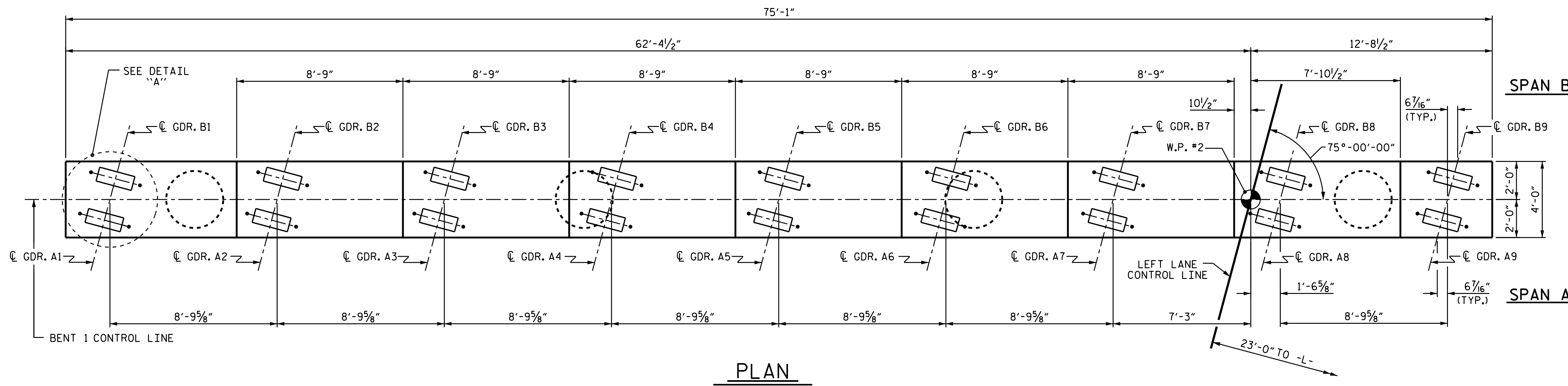

PROJECT NO. U-2579C
 FORSYTH COUNTY
 STATION: 473+70.00 -L-

SHEET 1 OF 2

STATE OF NORTH CAROLINA
 DEPARTMENT OF TRANSPORTATION
 RALEIGH

SUBSTRUCTURE
 BENT 1
 (LEFT LANE)

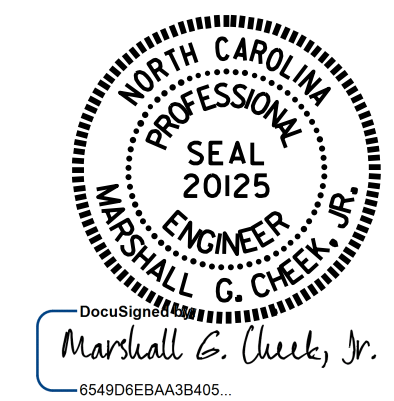

DRAWN BY: ARIADNE L. PALMA P. DATE: 7-27-16
 CHECKED BY: M.K. BEARD DATE: 8-16-16
 DESIGN ENGINEER OF RECORD: H.A. LOCKLEAR DATE: 6/2017

DOCUMENT NOT CONSIDERED FINAL UNLESS ALL SIGNATURES COMPLETED

REVISIONS						SHEET NO.
NO.	BY:	DATE:	NO.	BY:	DATE:	S3-24
1			3			TOTAL SHEETS
2			4			33

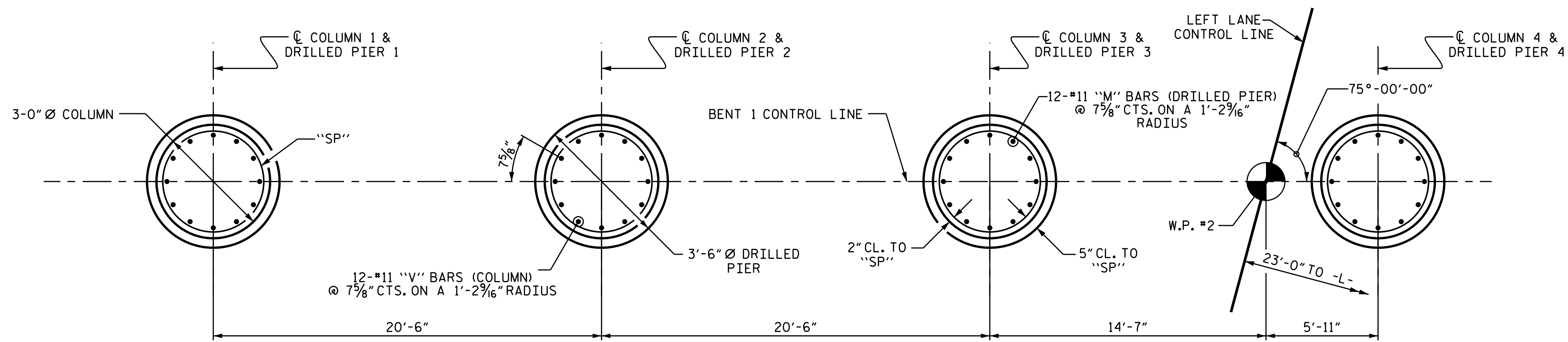

PLAN OF DRILLED PIERS & COLUMNS

DIMENSIONS AND REINFORCING STEEL ARE TYPICAL FOR EACH COLUMN & DRILLED PIER.

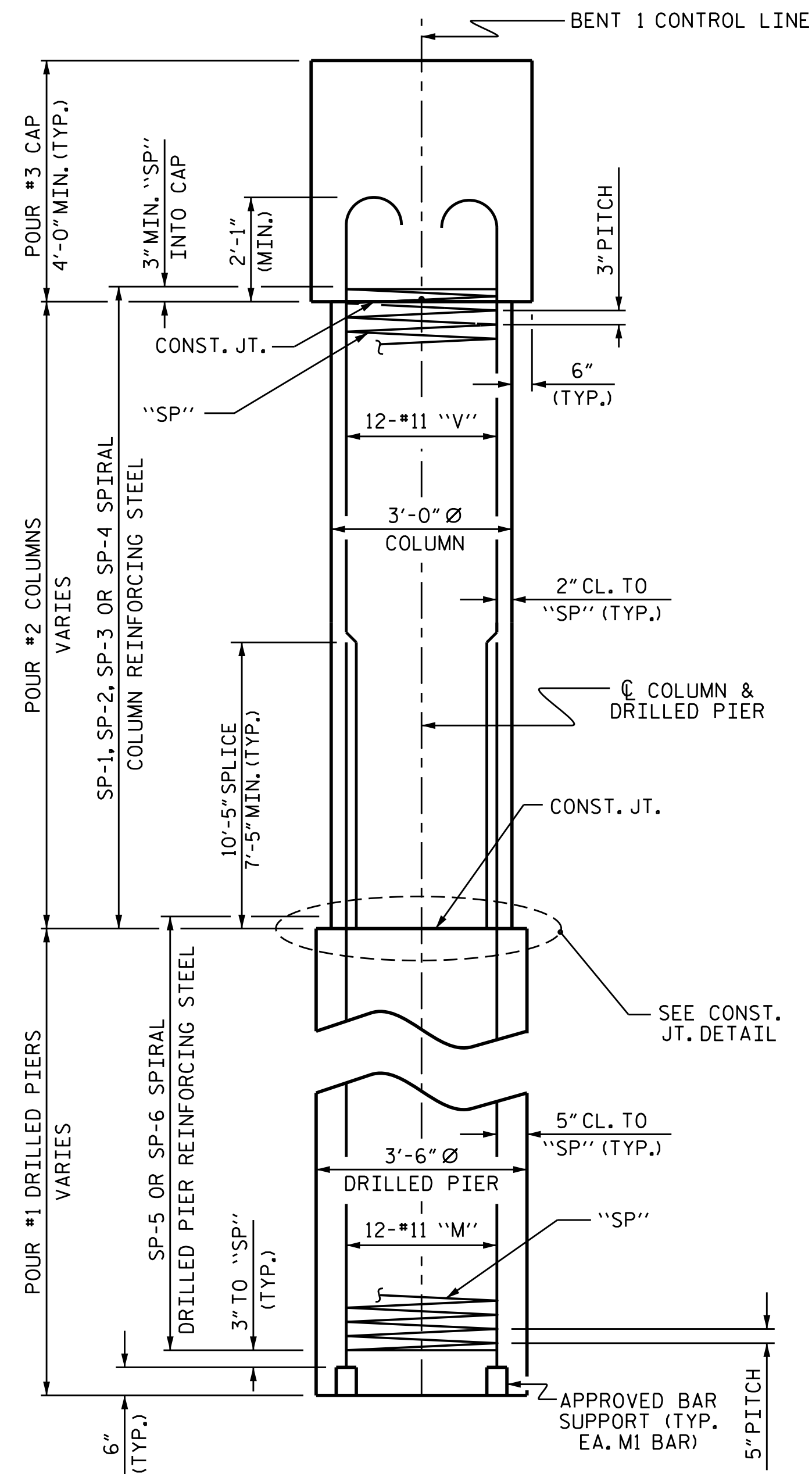

END ELEVATION

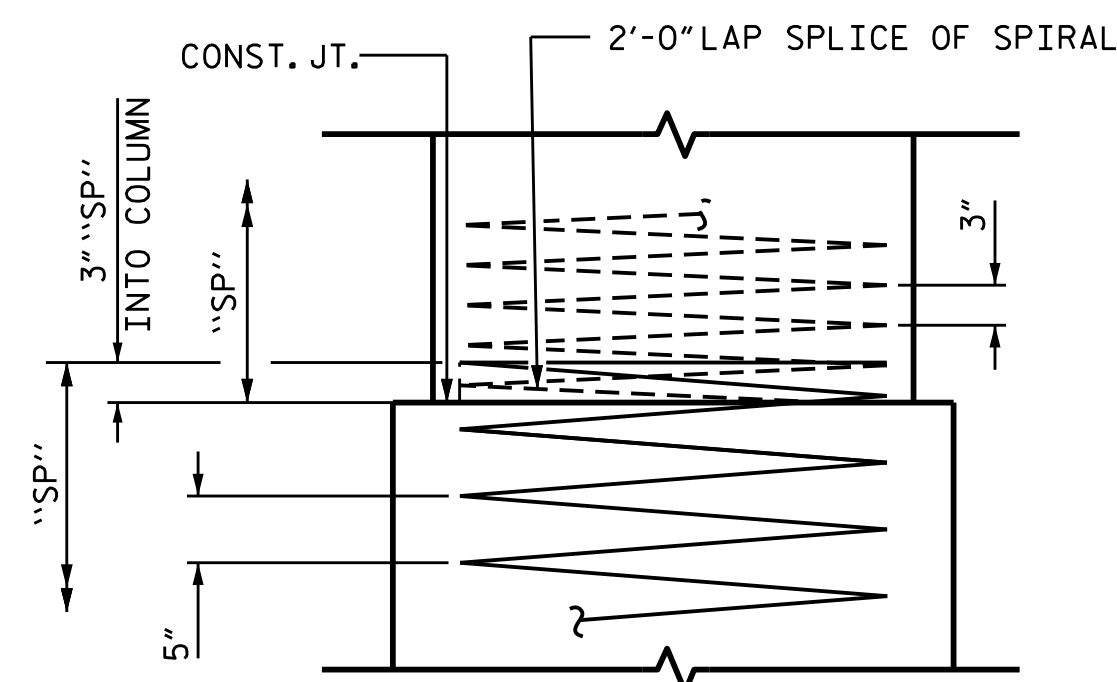

CONSTRUCTION JOINT DETAIL

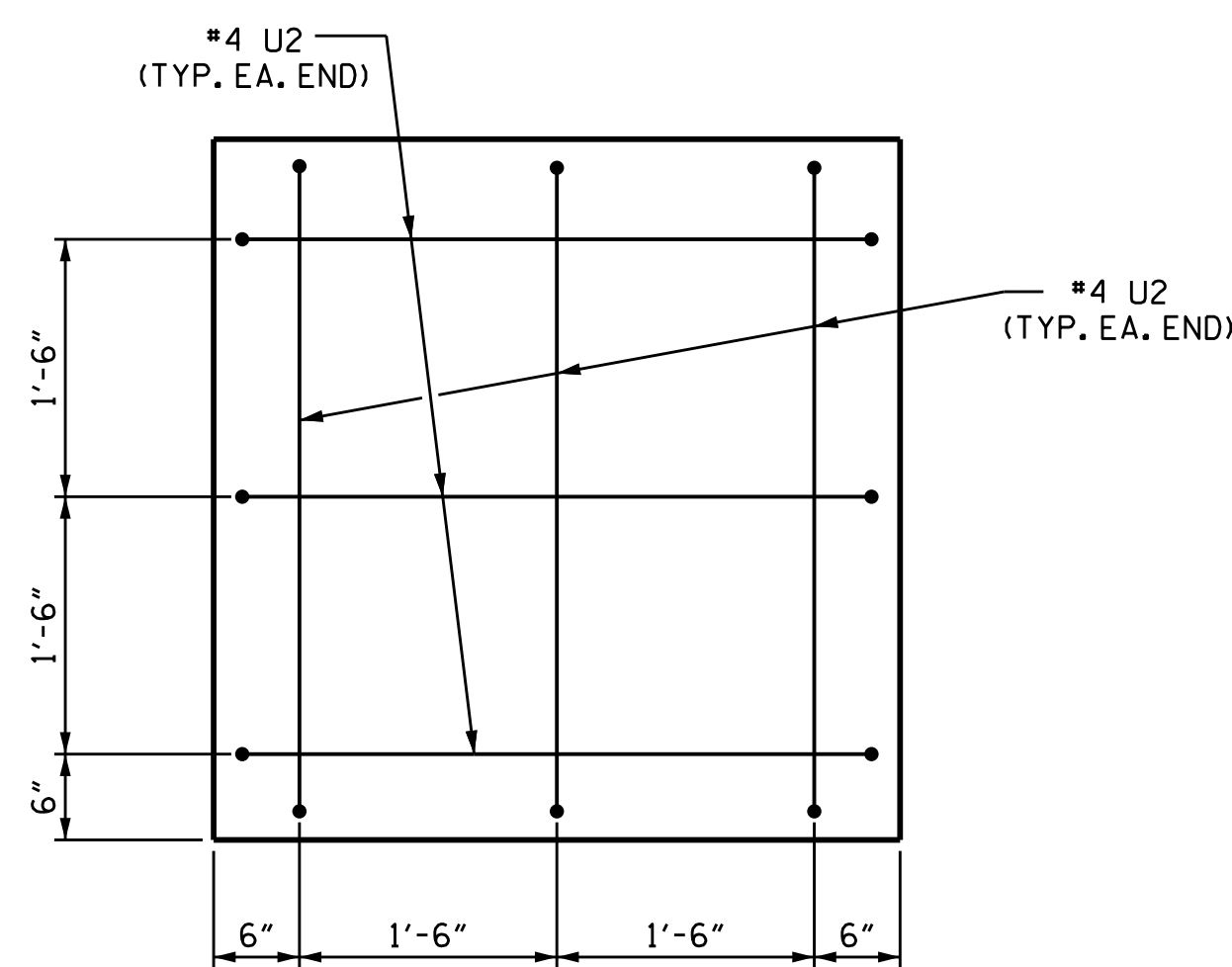

END OF CAP VIEW

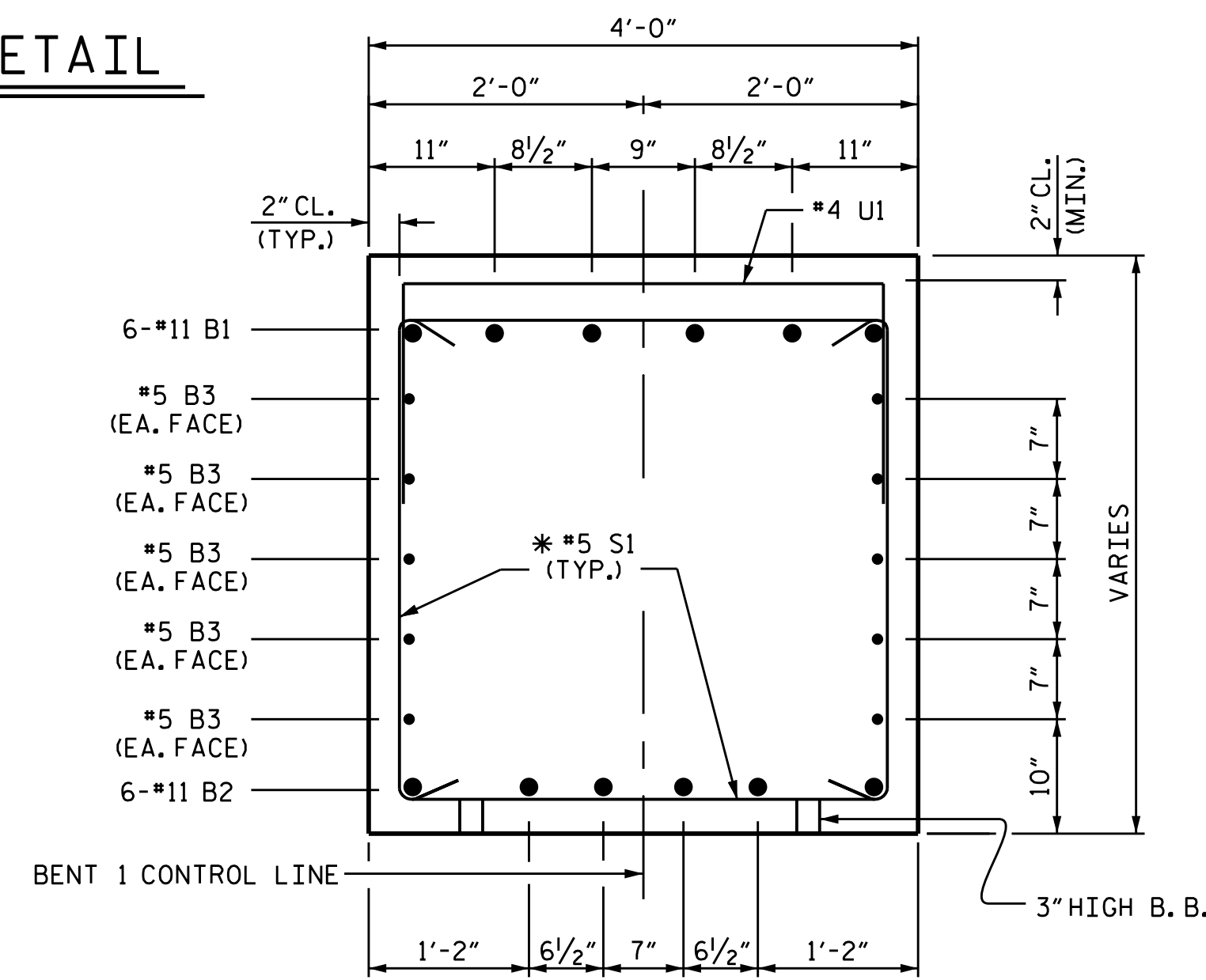

SECTION A-A

* INVERT ALTERNATE STIRRUPS

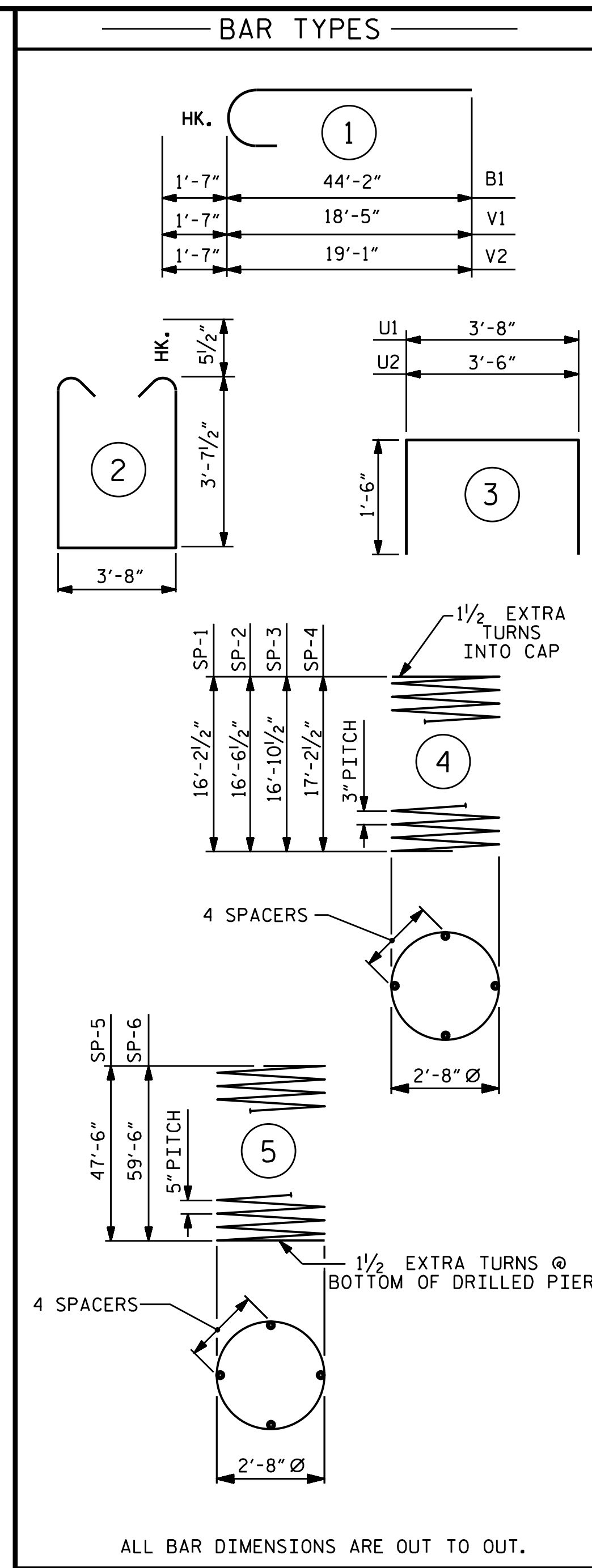

BILL OF MATERIAL

BENT 1					
BAR	NO.	SIZE	TYPE	LENGTH	WEIGHT
B1	12	#11		45'-9"	2917
B2	12	#11	STR	42'-3"	2694
B3	20	#5	STR	38'-6"	803
M1	24	#11	STR	58'-2"	7417
M2	48	#11	STR	38'-10"	9903
S1	84	#5	2	11'-10"	1037
U1	81	#4	3	6'-8"	361
U2	12	#4	3	6'-6"	52
V1	24	#11	1	20'-0"	2550
V2	24	#11	1	20'-8"	2635
REINFORCING STEEL					LBS. 30,369
SP-1	1	*	4	548'-8"	367
SP-2	1	*	4	559'-0"	373
SP-3	1	*	4	569'-4"	380
SP-4	1	*	4	581'-8"	389
SP-5	2	**	5	950'-0"	1982
SP-6	2	**	5	1188'-6"	2479
SPIRAL COLUMN REINFORCING STEEL					LBS. 5,970
* THE SP-1 THROUGH SP-4 SPIRAL REINFORCING STEEL SHALL BE W20 OR D-20 COLD DRAWN WIRE OR #4 PLAIN OR DEFORMED BAR.					
** THE SP-5 AND SP-6 SPIRAL REINFORCING STEEL SHALL BE W31 OR D-31 COLD DRAWN WIRE OR #5 PLAIN OR DEFORMED BAR.					
CLASS A CONCRETE BREAKDOWN					
POUR #2 (COLUMNS)				C.Y.	17.2
POUR #3 (CAP)				C.Y.	45.5
TOTAL CLASS A CONCRETE				C.Y.	62.7
DRILLED PIER QUANTITIES					
DRILLED PIER CONCRETE					
POUR #1 (DRILLED PIERS)				C.Y.	77.0
3'-6" DRILLED PIERS IN SOIL				LIN. FT.	154.00
3'-6" DRILLED PIERS NOT IN SOIL				LIN. FT.	62.00
PERMANENT STEEL CASING FOR 3'-6" DRILLED PIERS				LIN. FT.	32.00
SPT TESTING				4 EA.	
CSL TUBES				LIN. FT.	888.00

DRAWN BY: ARIADNE L. PALMA P. DATE: 7-27-16
 CHECKED BY: M.K. BEARD DATE: 8-16-16
 DESIGN ENGINEER OF RECORD: H.A. LOCKLEAR DATE: 6/2017

26-JUL-2017 15:07
 R:\Structures\FINAL PLANS\403.049.U-2579C.SMU.B.025.330702.dgn
 mcheek

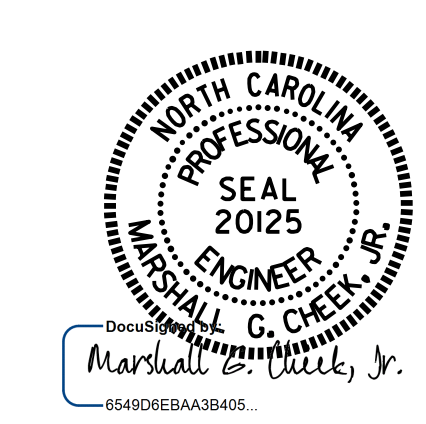

7/27/2017

PROJECT NO. U-2579C
 FORSYTH COUNTY
 STATION: 473+70.00 -L-

SHEET 2 OF 2
 DEPARTMENT OF TRANSPORTATION
 RALEIGH
 SUBSTRUCTURE
 BENT 1
 (LEFT LANE)

REVISIONS					
NO.	BY:	DATE:	NO.	BY:	DATE:
1			3		
2			4		

DOCUMENT NOT CONSIDERED FINAL UNLESS ALL SIGNATURES COMPLETED

SHEET NO.	
S3-25	TOTAL SHEETS 33

STR #3

NOTES

ALL STEEL IN THE DRILLED PIERS IS INCLUDED IN THE PAY ITEMS FOR "REINFORCING STEEL" AND "SPIRAL COLUMN REINFORCING STEEL".

THE CONTRACTOR'S ATTENTION IS CALLED TO THE FACT THAT THE LONGITUDINAL REINFORCEMENT FOR THE DRILLED PIERS IS DETAILED WITH 3 FEET OF EXTRA LENGTH.

THE LOCATION OF THE CONSTRUCTION JOINT IN THE DRILLED PIERS IS BASED ON AN APPROXIMATE GROUND LINE ELEVATION. IF THE CONSTRUCTION JOINT IS ABOVE THE ACTUAL GROUND LINE ELEVATION, THE CONTRACTOR SHALL PLACE THE CONSTRUCTION JOINT 1 FT. BELOW THE GROUND LINE.

STIRRUPS IN CAP MAY BE SHIFTED AS NECESSARY TO CLEAR ANCHOR BOLTS.

HOOKS ON "V" BARS MAY BE TURNED AS NECESSARY FOR PLACING REINFORCING STEEL.

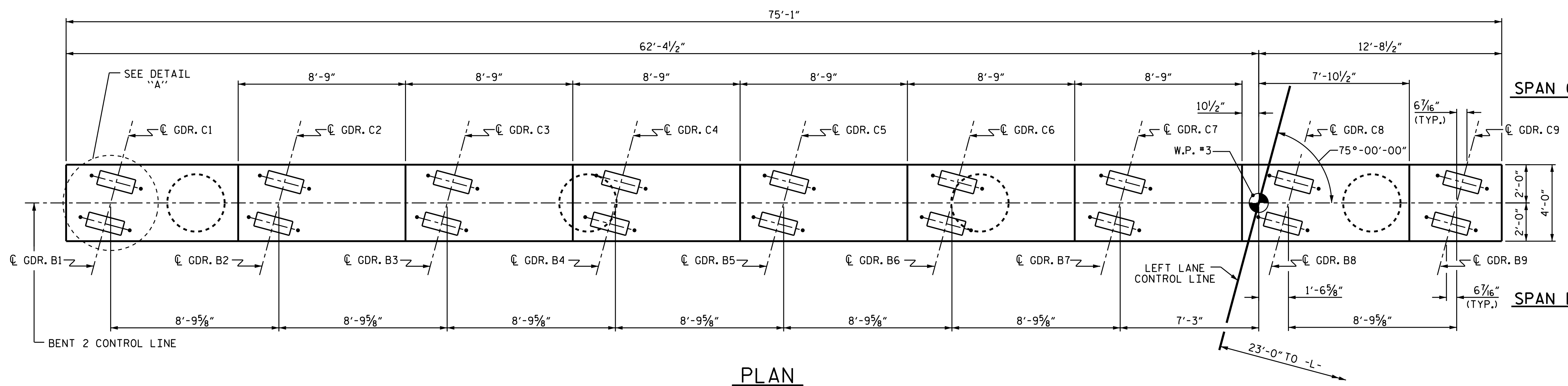

PLAN

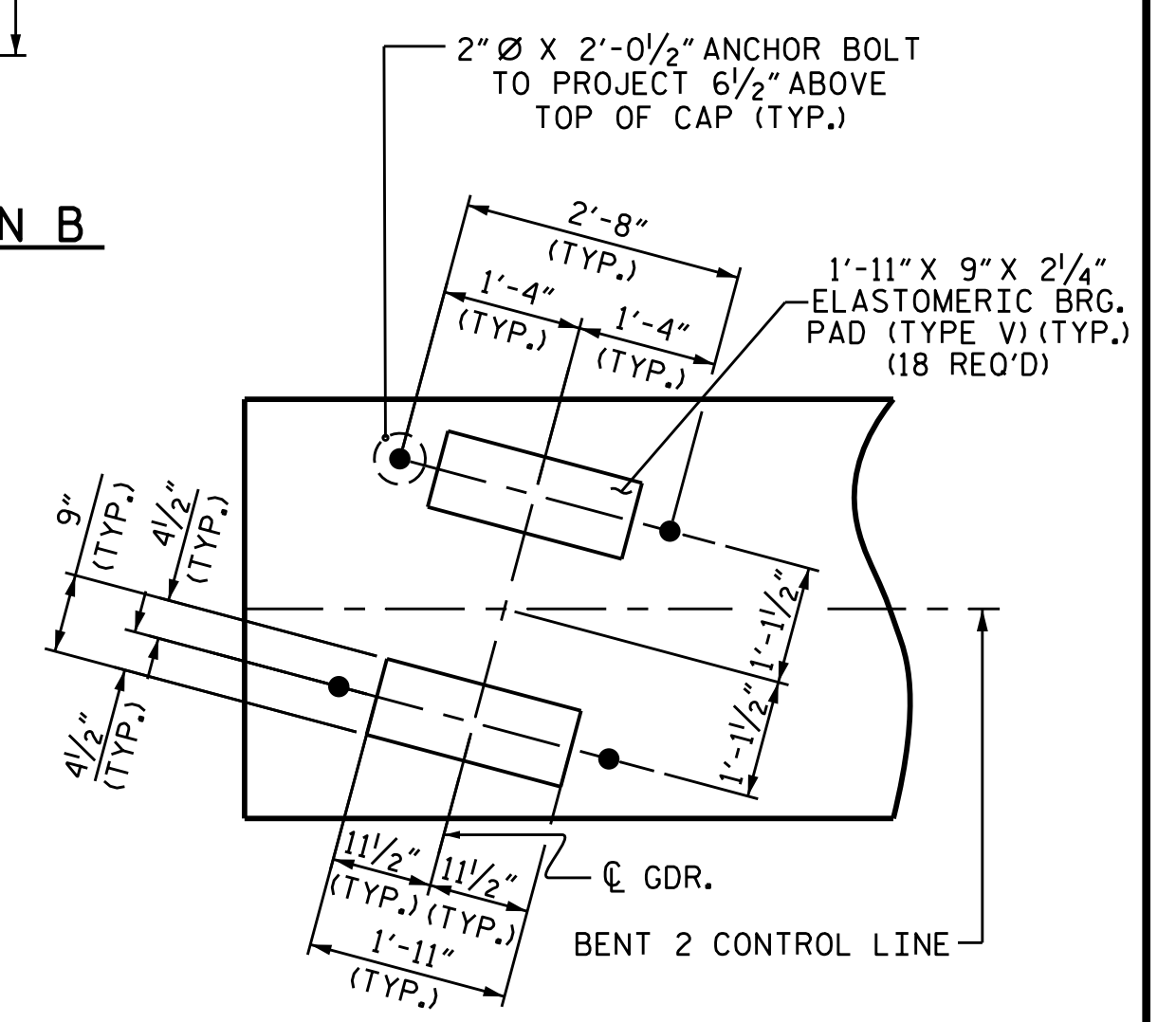

DETAIL "A"
TYP. EA. GDR.

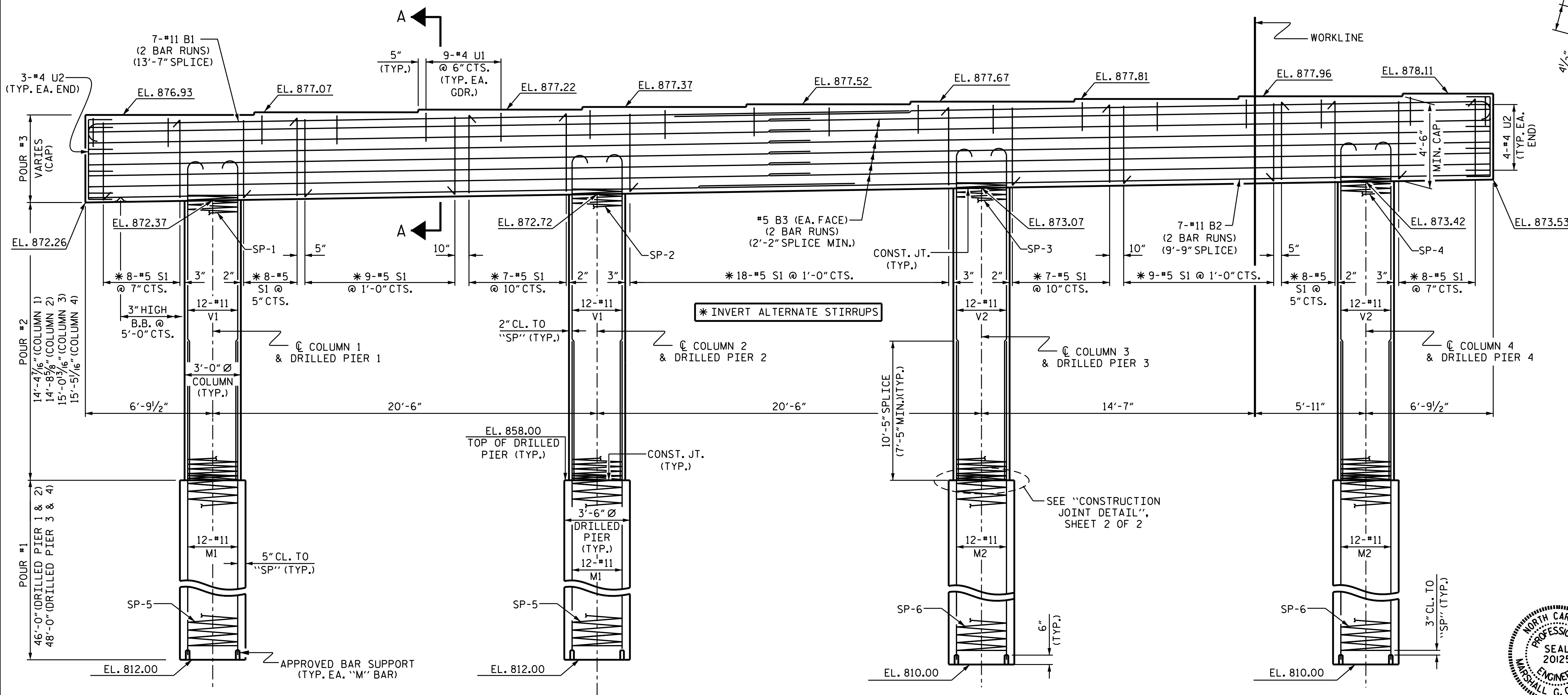

ELEVATION

PROJECT NO. U-2579C
 FORSYTH COUNTY
 STATION: 473+70.00 -L-

SHEET 1 OF 2

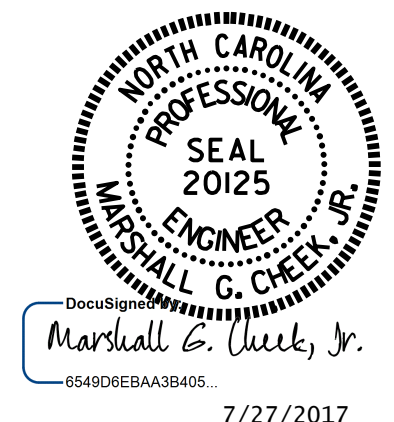

STATE OF NORTH CAROLINA
 DEPARTMENT OF TRANSPORTATION
 RALEIGH

SUBSTRUCTURE
BENT 2
(LEFT LANE)

DRAWN BY: ARIADNE L. PALMA / TLA DATE: 7-29-16
 CHECKED BY: M.K. BEARD DATE: 9/8/16
 DESIGN ENGINEER OF RECORD: H.A. LOCKLEAR DATE: 6/2017

DOCUMENT NOT CONSIDERED
 FINAL UNLESS ALL
 SIGNATURES COMPLETED

REVISIONS						SHEET NO.
NO.	BY:	DATE:	NO.	BY:	DATE:	S3-26
1			3			TOTAL SHEETS
2			4			33

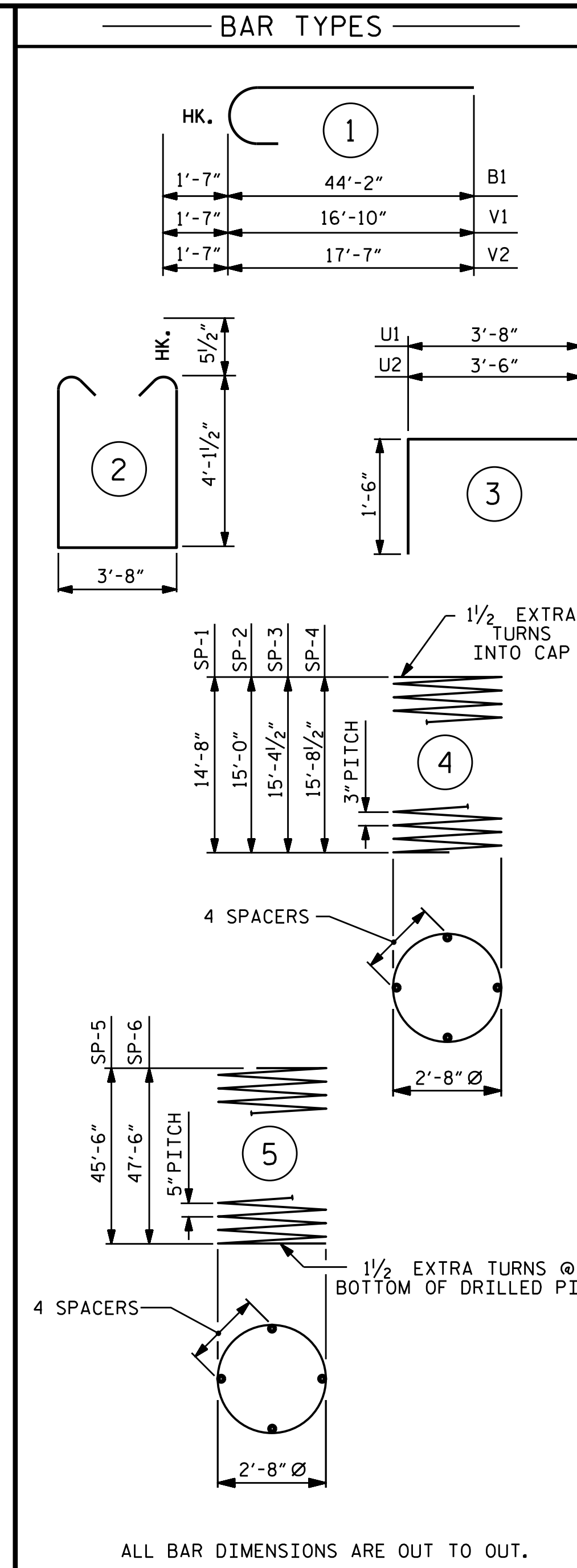
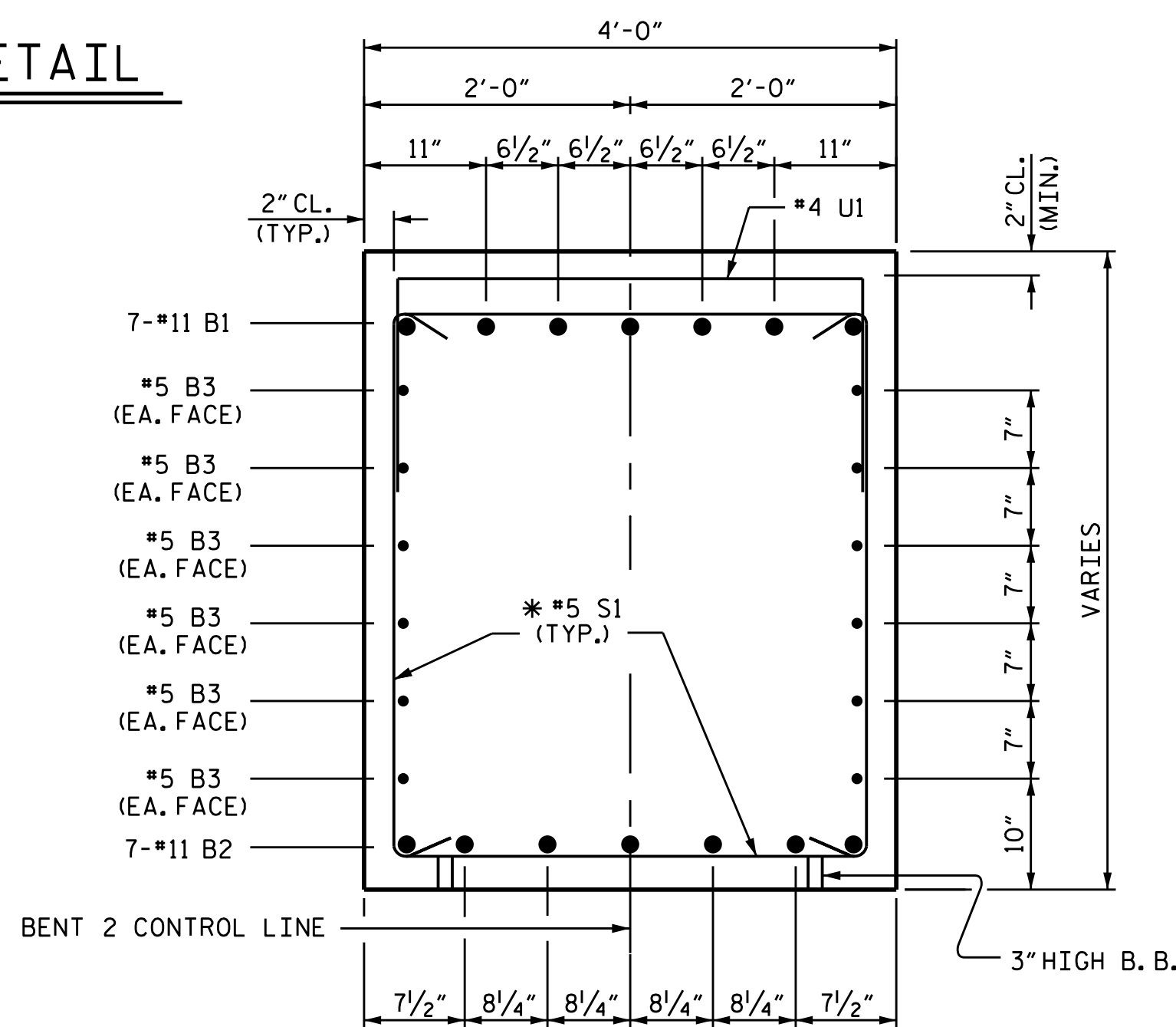
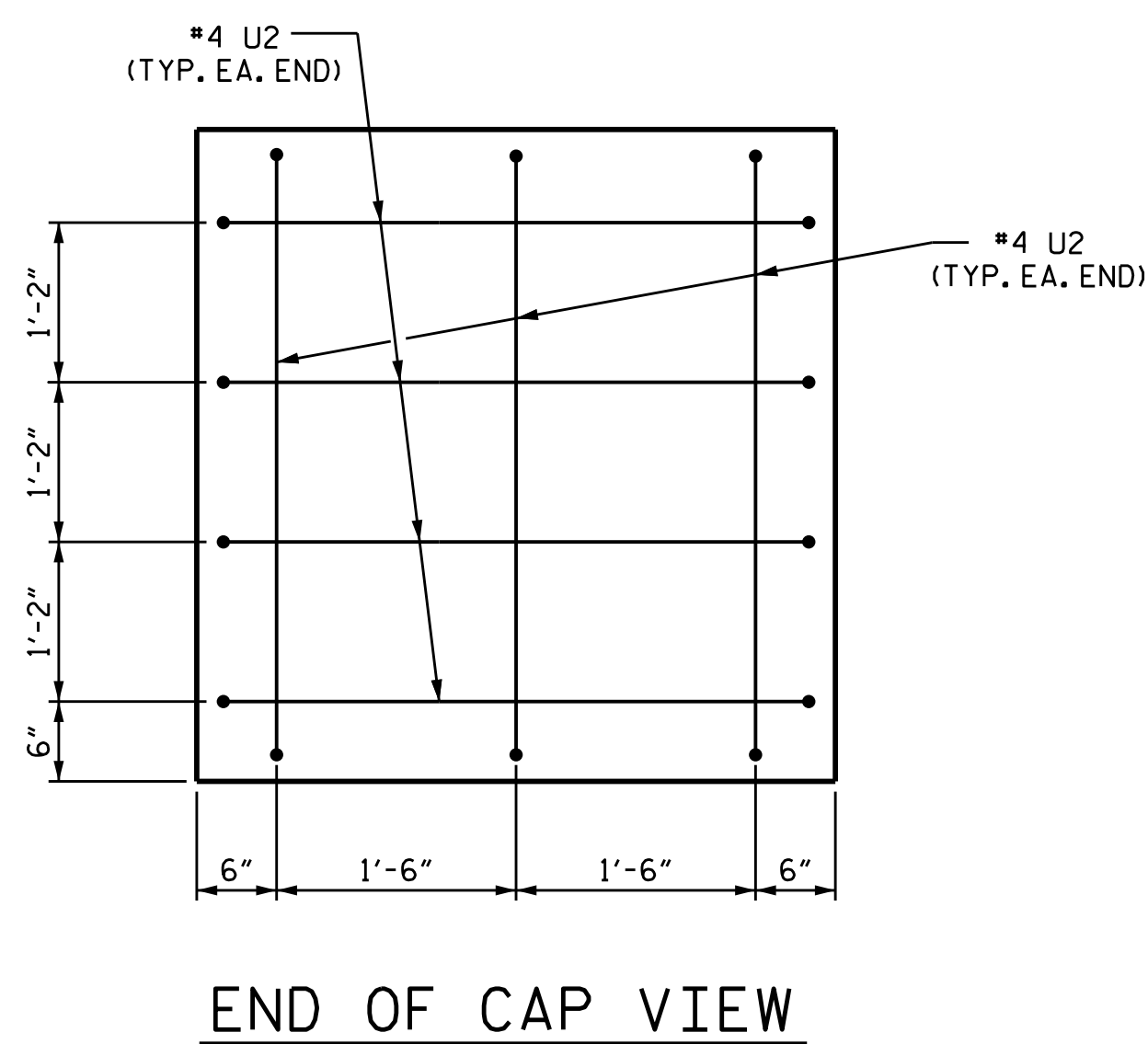
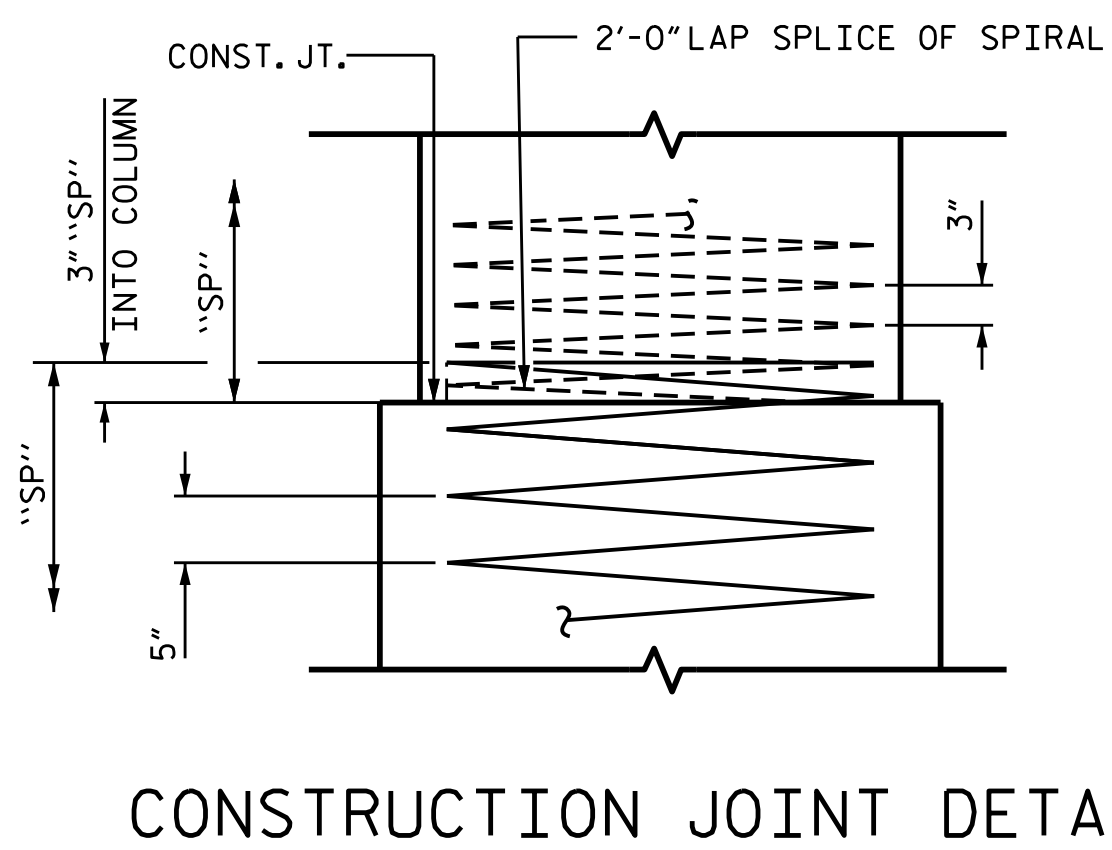
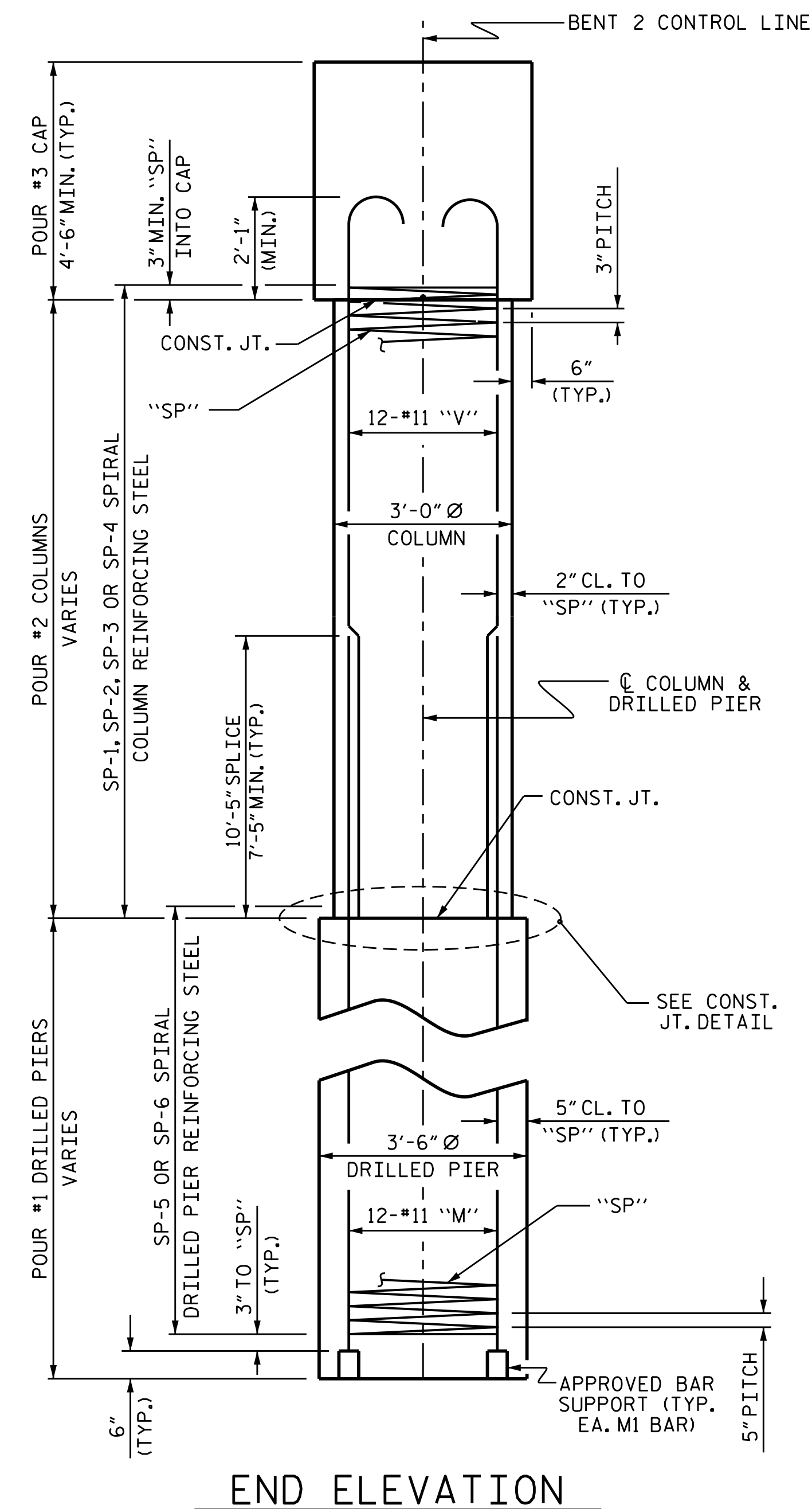
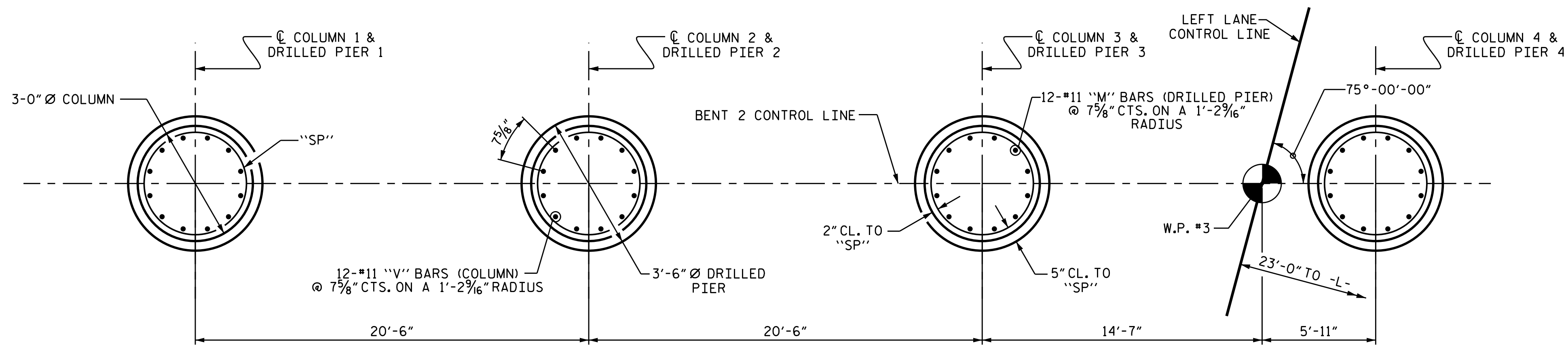

BILL OF MATERIAL					
BENT 2					
BAR NO.	SIZE	TYPE	LENGTH	WEIGHT	
B1	#11	1	45'-9"	3403	
B2	#11	STR	42'-3"	3143	
B3	#5	STR	38'-6"	964	
M1	#11	STR	55'-11"	7130	
M2	#11	STR	57'-11"	7385	
S1	#5	2	12'-10"	1098	
U1	#4	3	6'-8"	361	
U2	#4	3	6'-6"	61	
V1	#11	1	18'-5"	2348	
V2	#11	1	19'-2"	2444	
REINFORCING STEEL			LBS.	28,337	
SP-1	1	*	4	497'-2"	332
SP-2	1	*	4	507'-5"	339
SP-3	1	*	4	519'-10"	347
SP-4	1	*	4	532'-2"	355
SP-5	2	**	5	910'-11"	1900
SP-6	2	**	5	950'-0"	1982
SPIRAL COLUMN REINFORCING STEEL			LBS.	5,255	
* THE SP-1 THROUGH SP-4 SPIRAL REINFORCING STEEL SHALL BE W20 OR D-20 COLD DRAWN WIRE OR #4 PLAIN OR DEFORMED BAR.					
** THE SP-5 AND SP-6 SPIRAL REINFORCING STEEL SHALL BE W31 OR D-31 COLD DRAWN WIRE OR #5 PLAIN OR DEFORMED BAR.					
CLASS A CONCRETE BREAKDOWN					
POUR #2 (COLUMNS)	C.Y.	15.6			
POUR #3 (CAP)	C.Y.	51.1			
TOTAL CLASS A CONCRETE	C.Y.	66.7			
DRILLED PIER QUANTITIES					
DRILLED PIER CONCRETE					
POUR #1 (DRILLED PIERS)	C.Y.	67.0			
3'-6" Ø DRILLED PIERS IN SOIL	LIN. FT.	108.00			
3'-6" Ø DRILLED PIERS NOT IN SOIL	LIN. FT.	80.00			
PERMANENT STEEL CASING FOR 3'-6" Ø DRILLED PIERS	LIN. FT.	32.00			
SPT TESTING	EA.	4			
CSL TUBES	LIN. FT.	776.00			

PROJECT NO. U-2579C
 FORSYTH COUNTY
 STATION: 473+70.00 -L-
 SHEET 2 OF 2

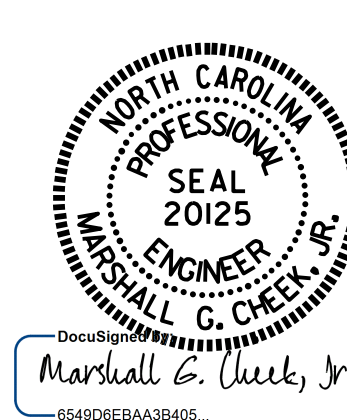

DEPARTMENT OF TRANSPORTATION RALEIGH					
SUBSTRUCTURE BENT 2 (LEFT LANE)					
REVISIONS					
NO.	BY:	DATE:	NO.	BY:	DATE:
1			3		
2			4		

SHEET NO. **S3-27**
 TOTAL SHEETS **33**

DRAWN BY: ARIADNE L. PALMA / TLA DATE: 7-27-16
 CHECKED BY: M.K. BEARD DATE: 9/8/16
 DESIGN ENGINEER OF RECORD: H.A. LOCKLEAR DATE: 6/2017

DOCUMENT NOT CONSIDERED FINAL UNLESS ALL SIGNATURES COMPLETED

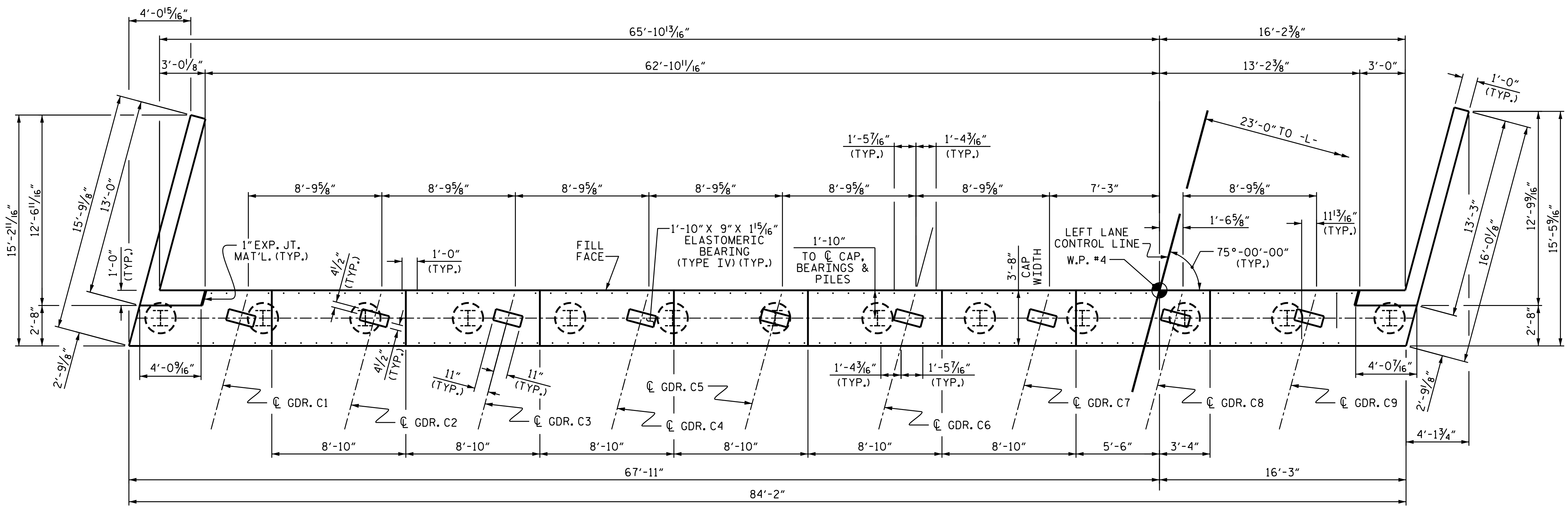

PLAN

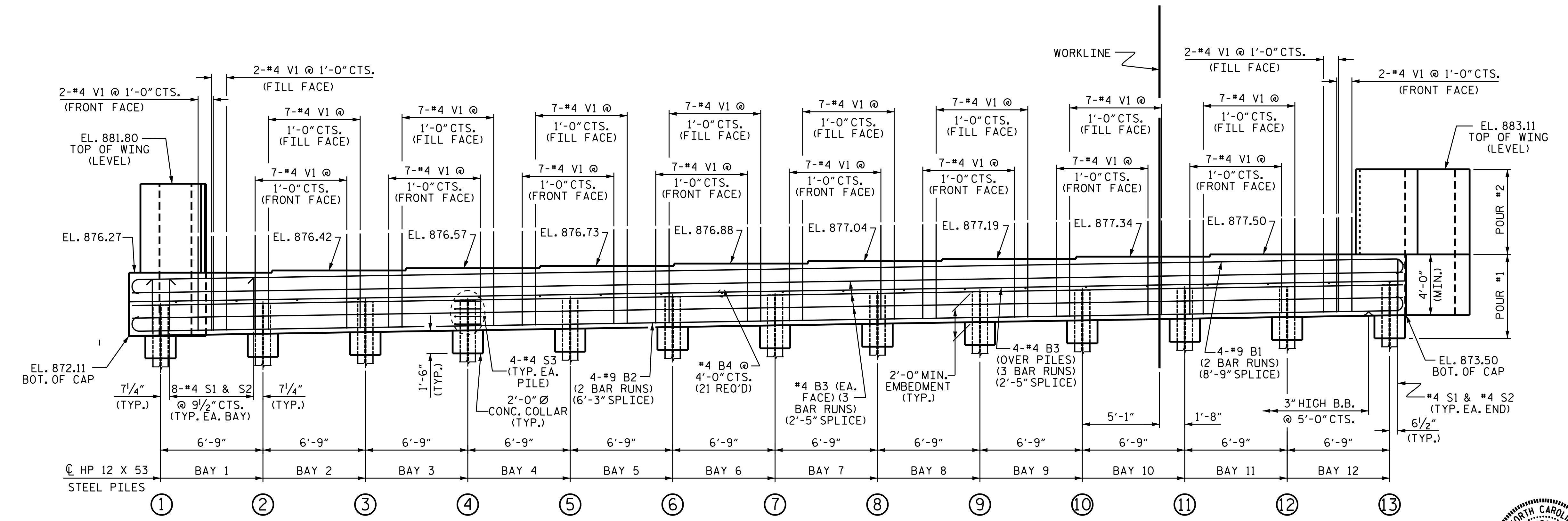

ELEVATION

NOTES

THE TOP SURFACE OF THE END BENT CAP, EXCEPT THE BEARING AREA, SHALL BE RAKED TO A DEPTH OF 1/4".

TOP OF PILE ELEVATIONS

①	874.12
②	874.23
③	874.34
④	874.45
⑤	874.57
⑥	874.68
⑦	874.79
⑧	874.90
⑨	875.01
⑩	875.12
⑪	875.23
⑫	875.35
⑬	875.46

PROJECT NO. U-2579C
 FORSYTH COUNTY
 STATION: 473+70.00 -L-

SHEET 1 OF 3

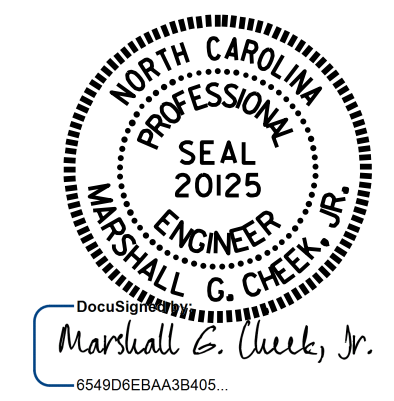

STATE OF NORTH CAROLINA
 DEPARTMENT OF TRANSPORTATION
 RALEIGH
 SUBSTRUCTURE
 INTEGRAL
 END BENT 2
 (LEFT LANE)

DRAWN BY: H.A. LOCKLEAR DATE: 6/15/16
 CHECKED BY: K.D. LAYNE DATE: 8/3/16
 DESIGN ENGINEER OF RECORD: H.A. LOCKLEAR DATE: 8/18/16

DOCUMENT NOT CONSIDERED FINAL UNLESS ALL SIGNATURES COMPLETED

REVISIONS				SHEET NO.	
NO.	BY:	DATE:	NO.	BY:	DATE:
1			3		
2			4		

S3-28
 TOTAL SHEETS 33

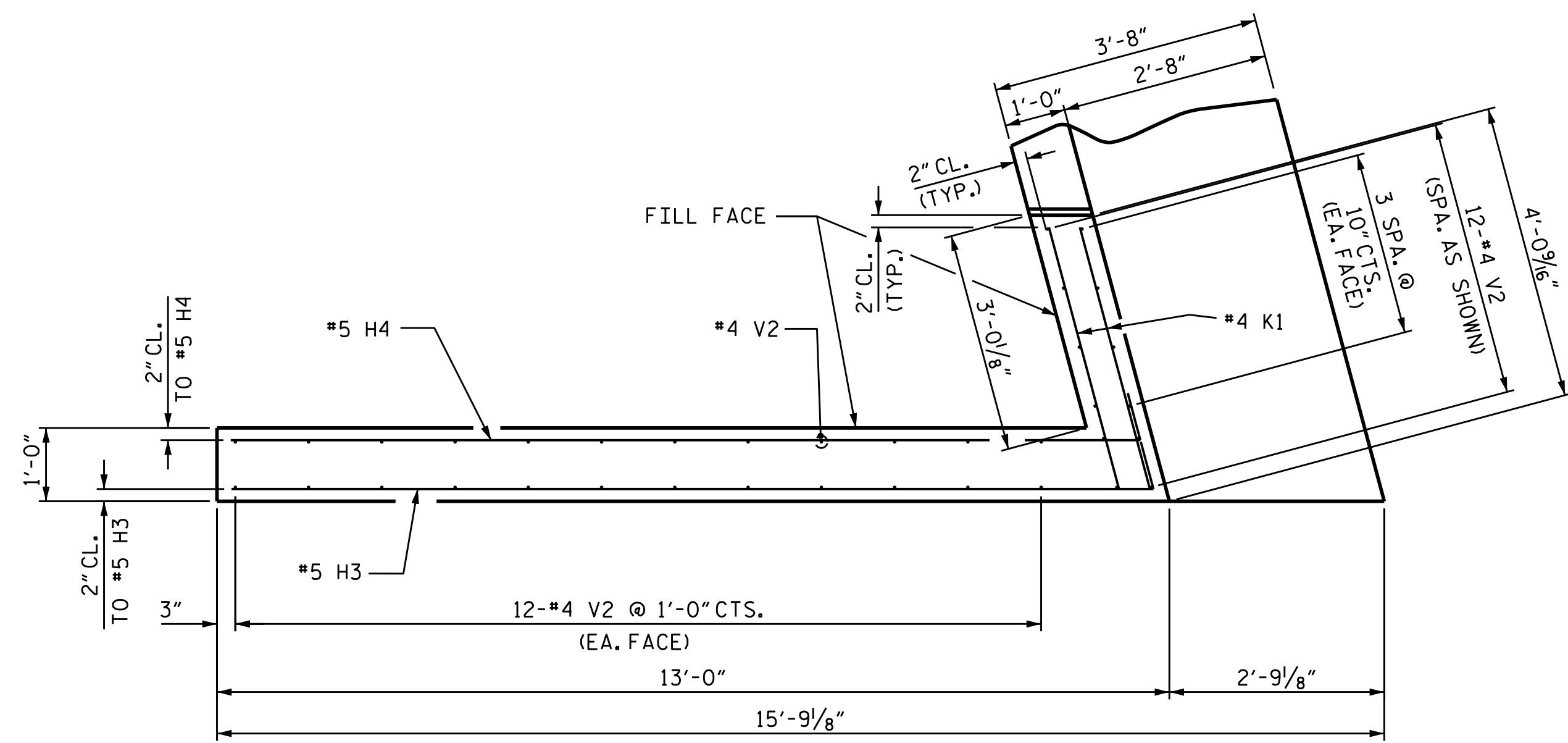

PLAN OF LEFT WING

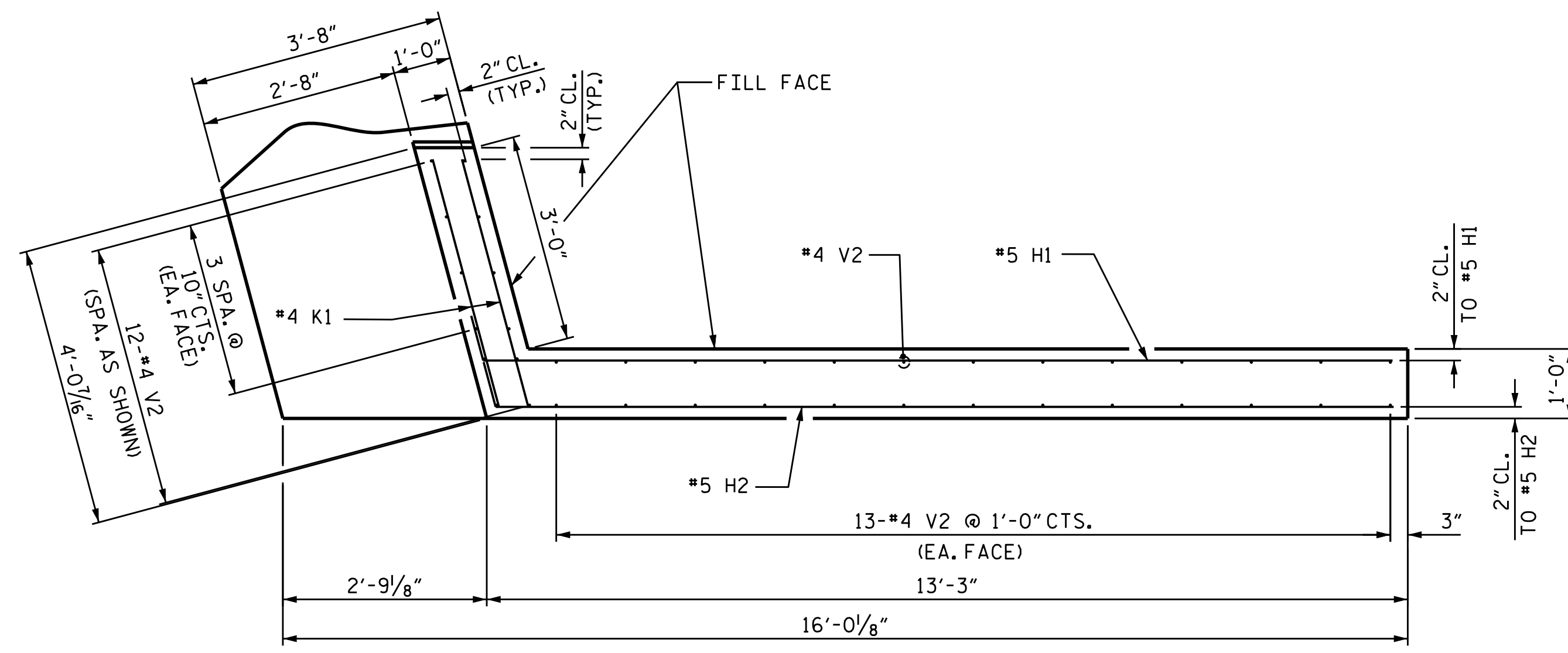

PLAN OF RIGHT WING

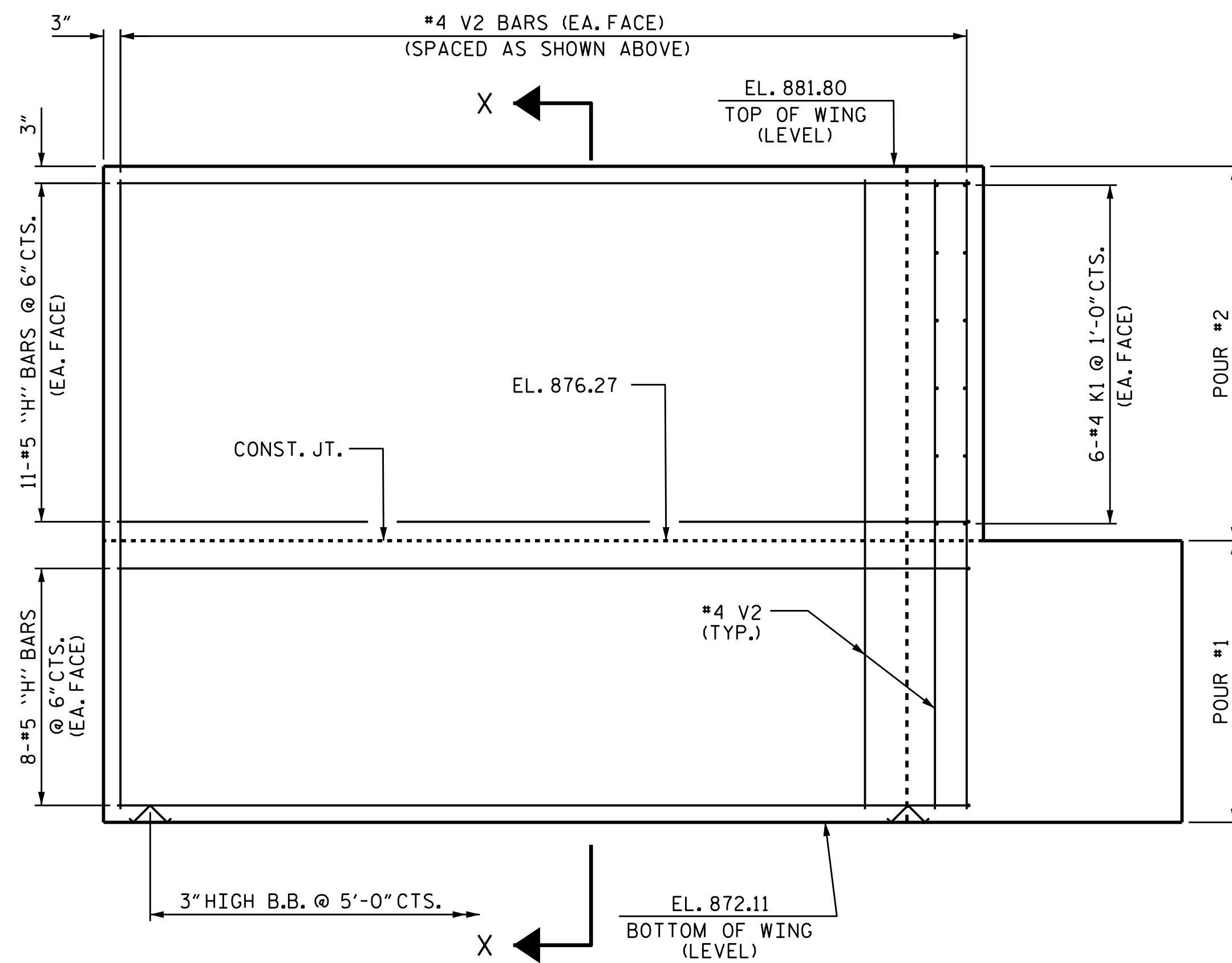

ELEVATION OF LEFT WING

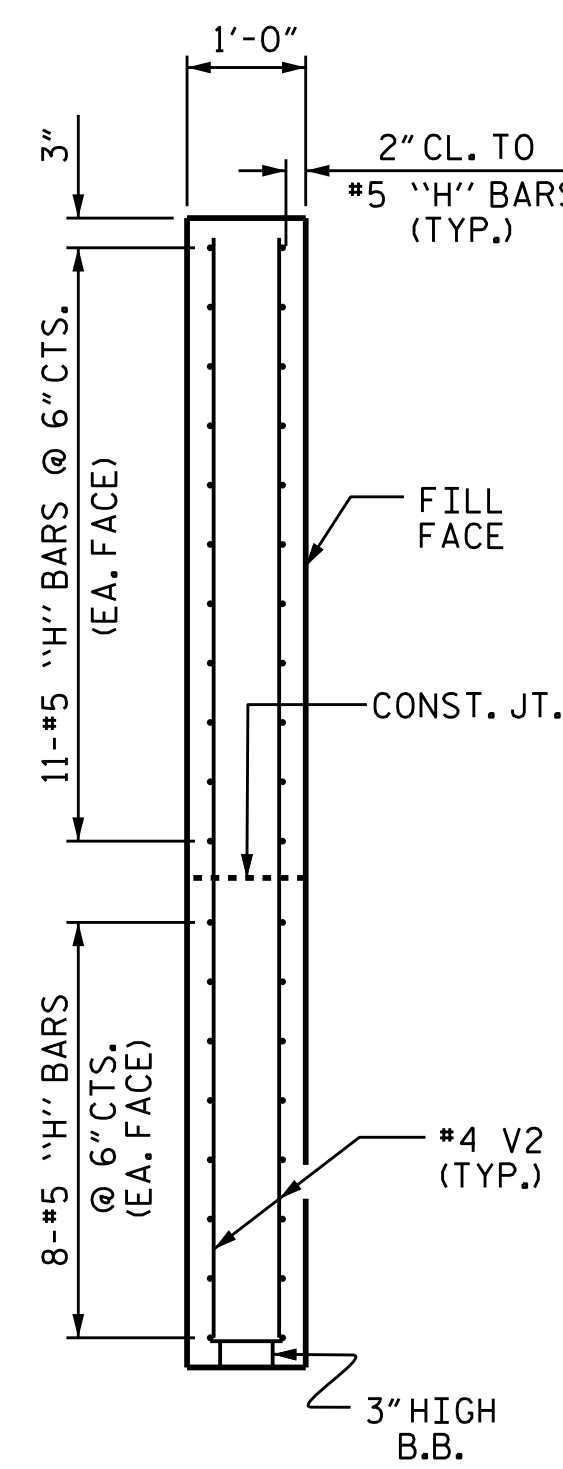

SECTION X-X

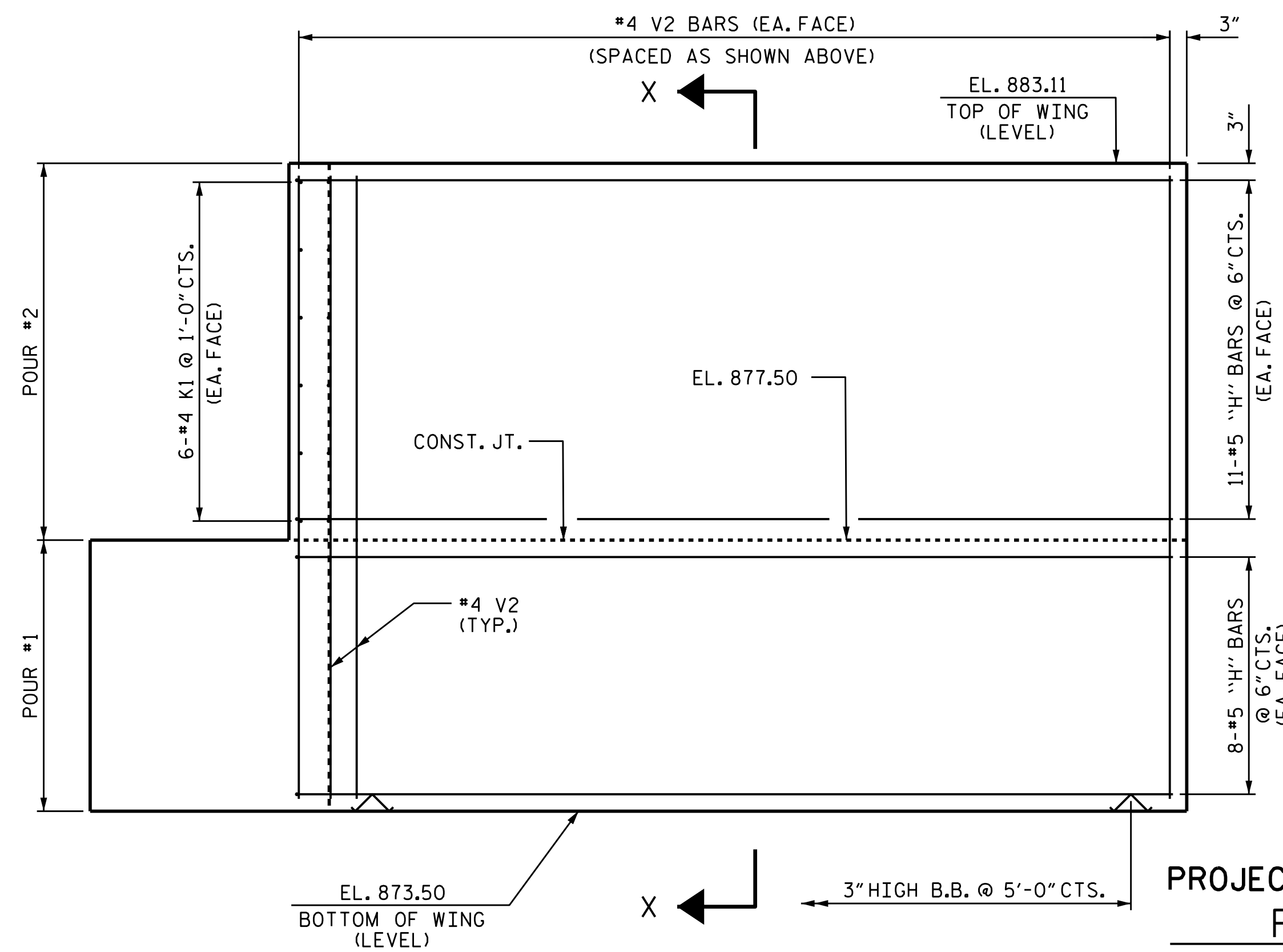

ELEVATION OF RIGHT WING

PROJECT NO. U-2579C
 FORSYTH COUNTY
 STATION: 473+70.00 -L-

SHEET 2 OF 3

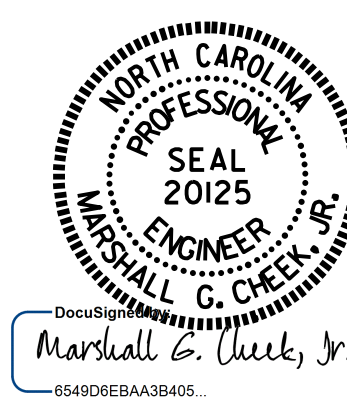

STATE OF NORTH CAROLINA
 DEPARTMENT OF TRANSPORTATION
 RALEIGH
 SUBSTRUCTURE
 INTEGRAL
 END BENT 2
 (LEFT LANE)

DRAWN BY: H.A. LOCKLEAR DATE: 6/22/16
 CHECKED BY: K.D. LAYNE DATE: 8/3/16
 DESIGN ENGINEER OF RECORD: H.A. LOCKLEAR DATE: 8/18/16

DOCUMENT NOT CONSIDERED
 FINAL UNLESS ALL
 SIGNATURES COMPLETED

REVISIONS						SHEET NO.	
NO.	BY:	DATE:	NO.	BY:	DATE:	TOTAL SHEETS	
1			3			S3-29	
2			4			33	

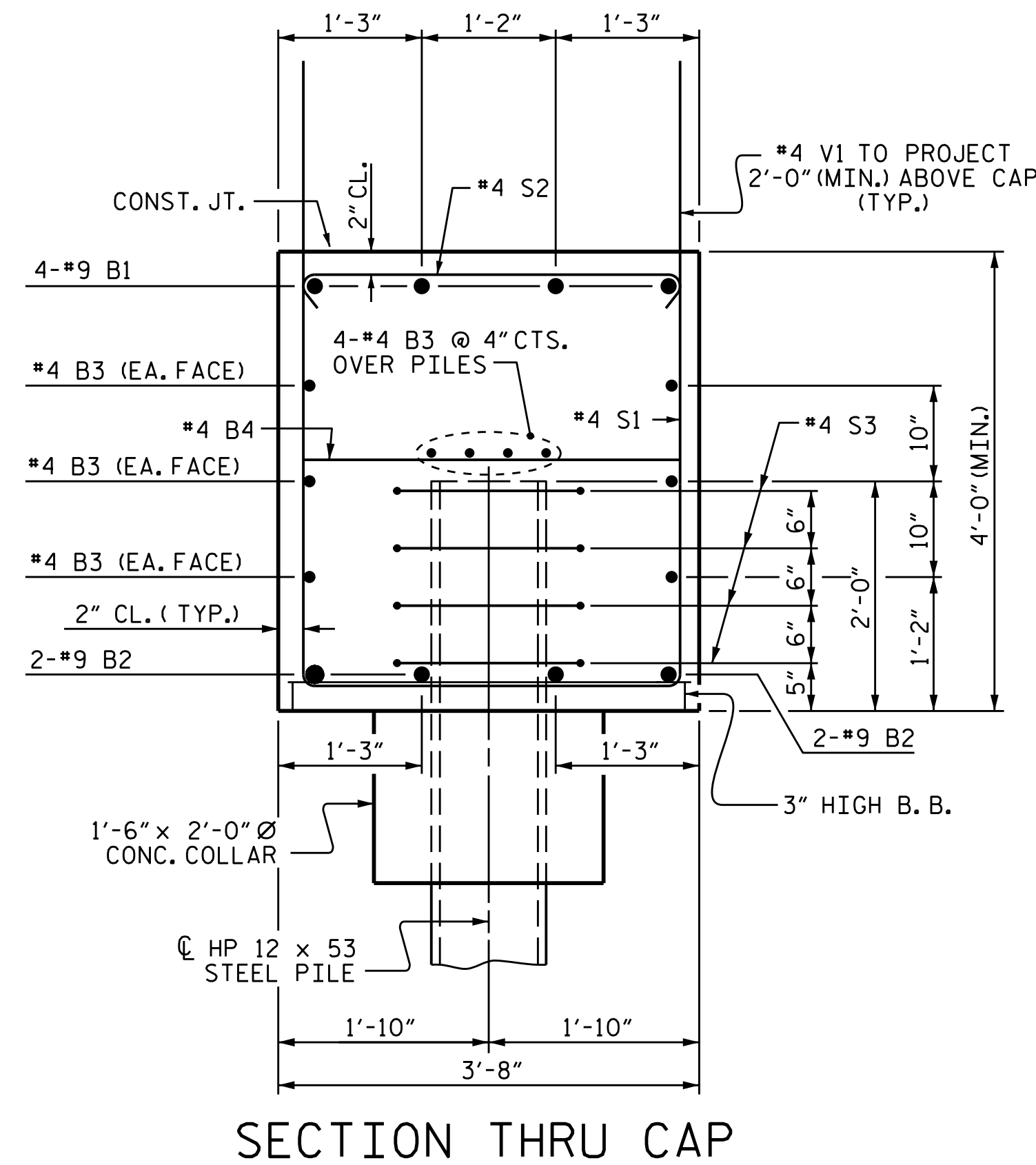

SECTION THRU CAP

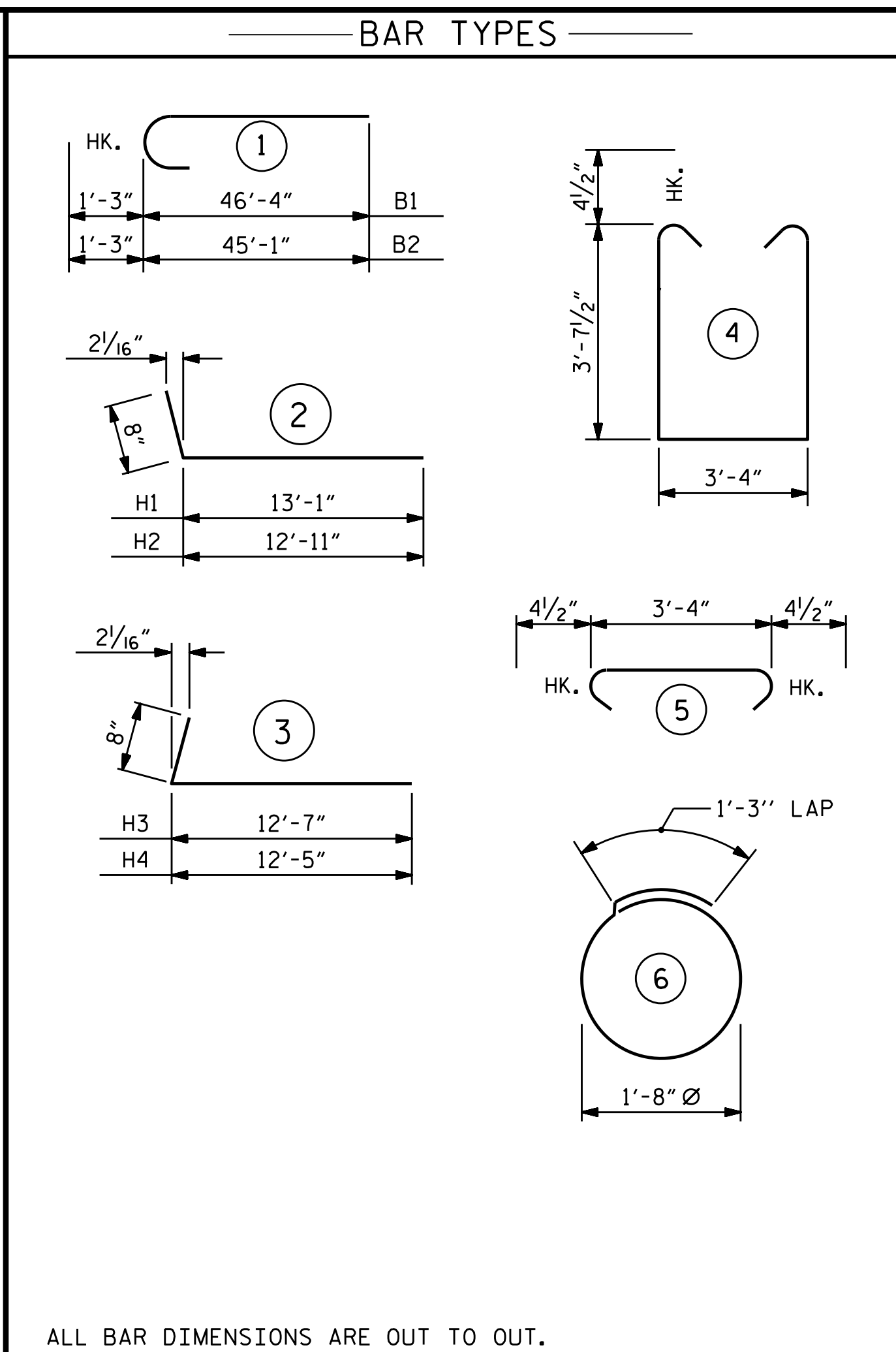

BILL OF MATERIAL					
INTEGRAL END BENT 2					
BAR NO.	SIZE	TYPE	LENGTH	WEIGHT	
B1	#8	#9	1	47'-7"	1294
B2	8	#9	1	46'-4"	1260
B3	30	#4	STR	29'-7"	593
B4	21	#4	STR	3'-4"	47
H1	19	#5	2	13'-9"	272
H2	19	#5	2	13'-7"	269
H3	19	#5	3	13'-3"	263
H4	19	#5	3	13'-1"	259
K1	24	#4	STR	3'-8"	59
S1	98	#4	4	11'-4"	742
S2	98	#4	5	4'-1"	267
S3	52	#4	6	6'-6"	226
V1	120	#4	STR	6'-0"	481
V2	74	#4	STR	9'-3"	457
REINFORCING STEEL				LBS.	6489
CLASS A CONCRETE					
POUR #1 CAP, LOWER WINGS & CONC. COLLARS				C.Y.	52.8
POUR #2 UPPER PART OF WINGS				C.Y.	6.7
TOTAL CLASS A CONCRETE				C.Y.	59.5
HP 12 X 53 STEEL PILES					
NO.: 13				LIN. FT.	750
PILE DRIVING EQUIPMENT SETUP FOR HP 12 X 53 STEEL PILES					
				EACH	13

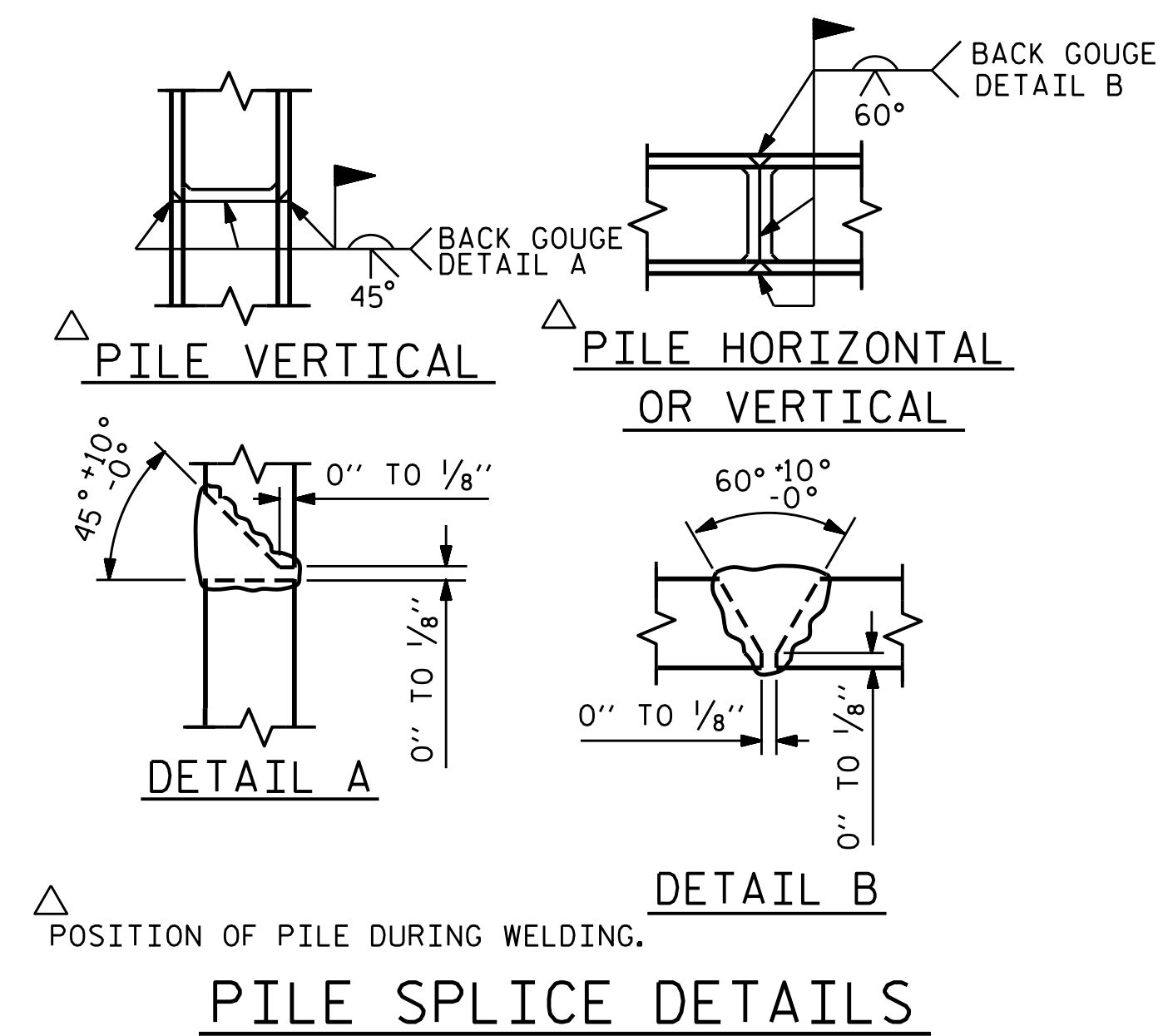

PILE SPLICE DETAILS

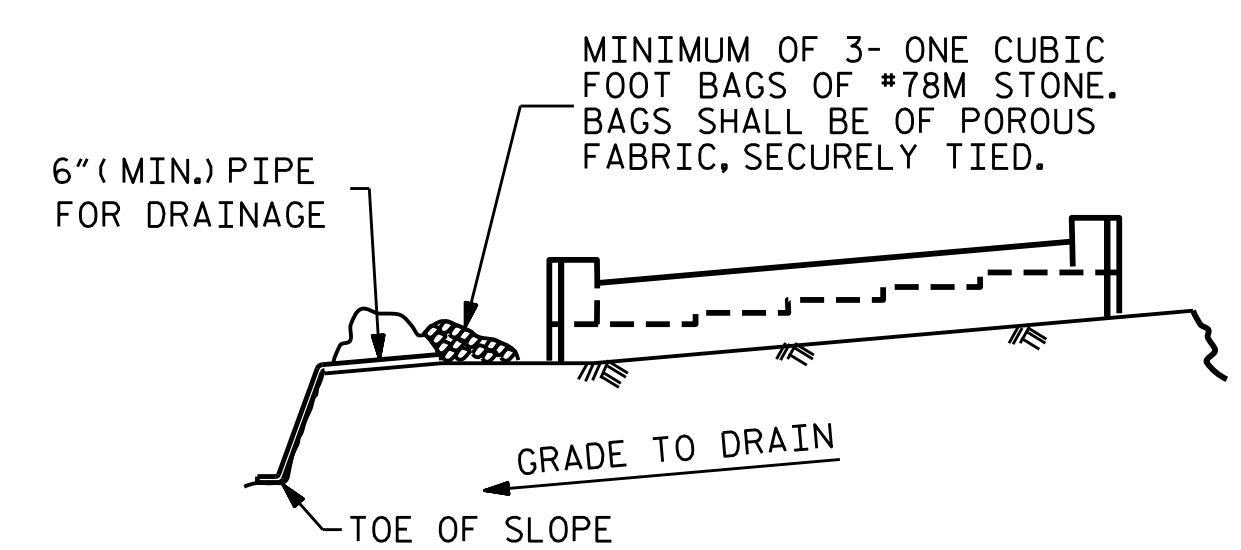

BAGGED STONE AND PIPE SHALL BE PLACED IMMEDIATELY AFTER COMPLETION OF END BENT EXCAVATION. PIPE MAY BE EITHER CONCRETE, CORRUGATED STEEL, CORRUGATED ALUMINUM ALLOY, OR CORRUGATED PLASTIC. PERFORATED PIPE WILL NOT BE ALLOWED.

BAGGED STONE SHALL REMAIN IN PLACE UNTIL THE ENGINEER DIRECTS THAT IT BE REMOVED. THE CONTRACTOR SHALL REMOVE AND DISPOSE OF SILT ACCUMULATIONS AT BAGGED STONE WHEN SO DIRECTED BY THE ENGINEER. BAGS SHALL BE REMOVED AND REPLACED WHENEVER THE ENGINEER DETERMINES THAT THEY HAVE DETERIORATED AND LOST THEIR EFFECTIVENESS.

NO SEPARATE PAYMENT WILL BE MADE FOR THIS WORK AND THE ENTIRE COST OF THIS WORK SHALL BE INCLUDED IN THE UNIT CONTRACT PRICE BID FOR THE SEVERAL PAY ITEMS.

TEMPORARY DRAINAGE AT END BENT

PROJECT NO. U-2579C
FORSYTH COUNTY
 STATION: 473+70.00 -L-

SHEET 3 OF 3

STATE OF NORTH CAROLINA
 DEPARTMENT OF TRANSPORTATION
 RALEIGH

SUBSTRUCTURE
 INTEGRAL
 END BENT 2
 (LEFT LANE)

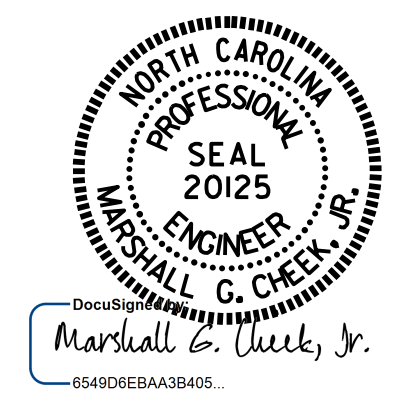

7/27/2017

DRAWN BY : H.A. LOCKLEAR DATE : 6/23/16
 CHECKED BY : K.D. LAYNE DATE : 8/3/16
 DESIGN ENGINEER OF RECORD: H.A. LOCKLEAR DATE : 8/18/16

DOCUMENT NOT CONSIDERED FINAL UNLESS ALL SIGNATURES COMPLETED

REVISIONS						SHEET NO.	
NO.	BY:	DATE:	NO.	BY:	DATE:	S3-30	
1			3			TOTAL SHEETS	
2			4			33	

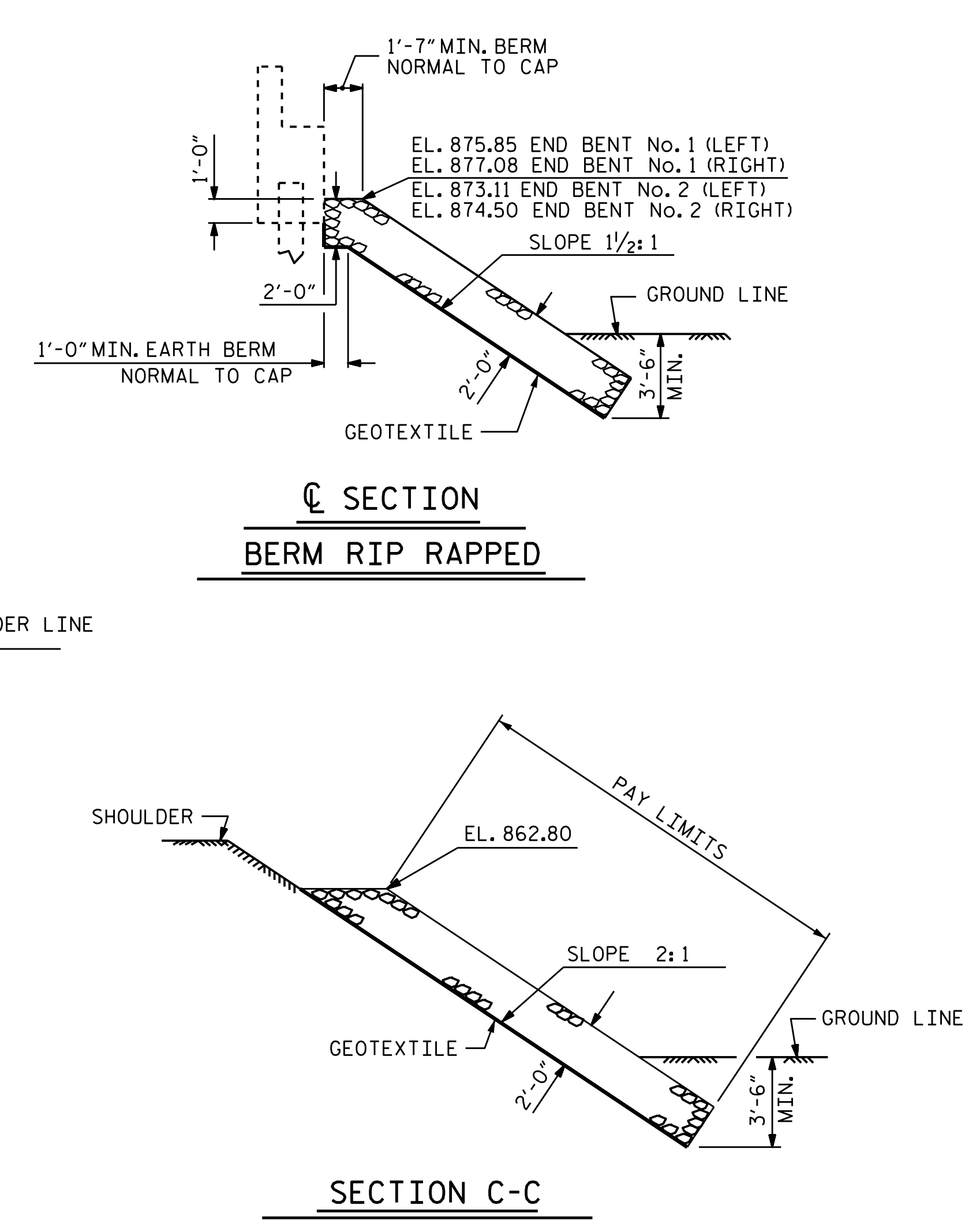
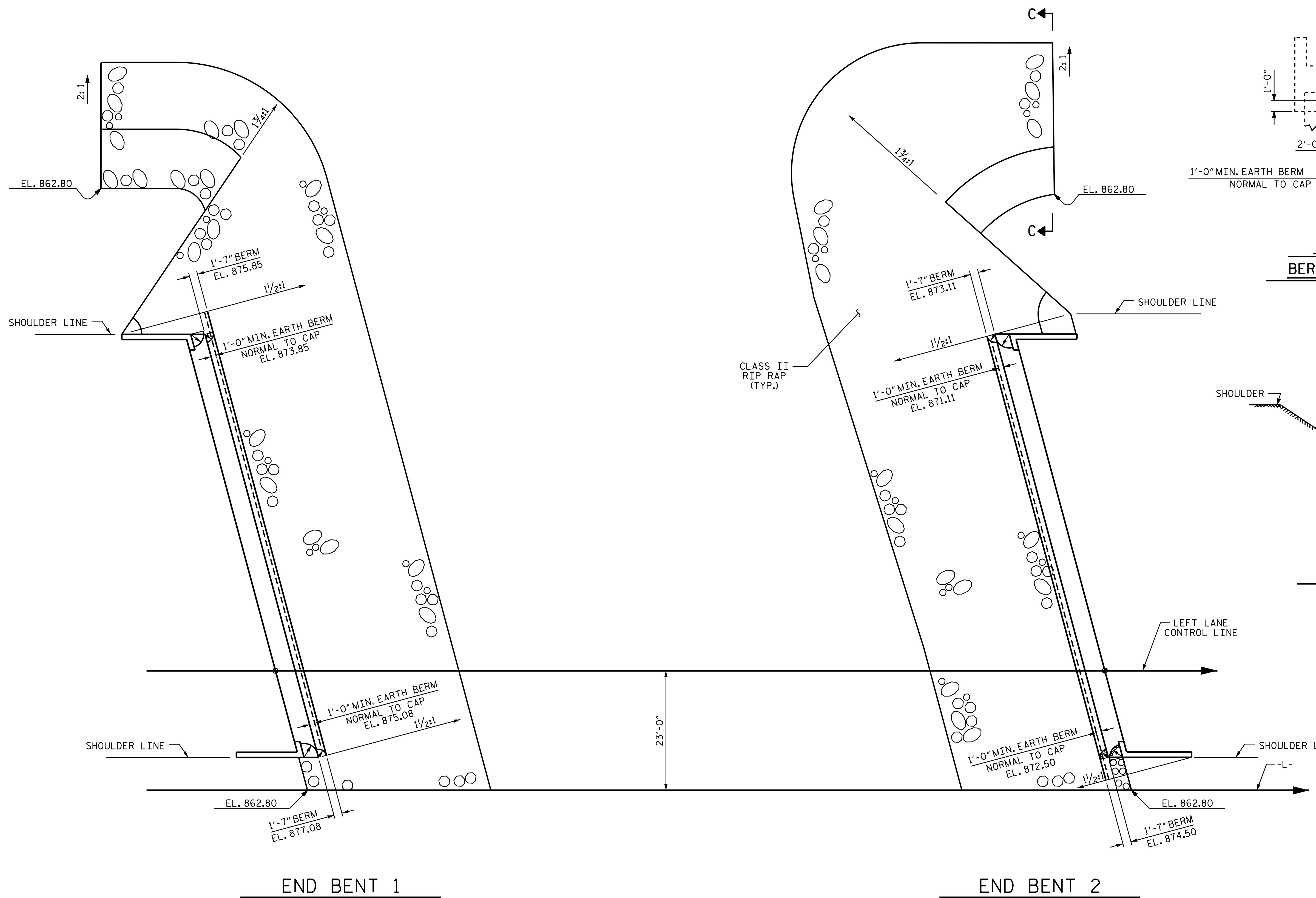

PROJECT NO. U-2579C
FORSYTH COUNTY
 STATION: 473+70.00 -L-

ESTIMATED QUANTITIES		
BRIDGE @ STA. 473+70.00 -L- (LEFT LANE)	RIP RAP CLASS II (2'-0" THICK)	GEOTEXTILE FOR DRAINAGE
	TONS	SQUARE YARDS
END BENT 1	530	590
END BENT 2	515	570
TOTAL	1045	1160



STATE OF NORTH CAROLINA
 DEPARTMENT OF TRANSPORTATION
 RALEIGH

**RIP RAP
 DETAILS
 (LEFT LANE)**

REVISIONS						SHEET NO.
NO.	BY:	DATE:	NO.	BY:	DATE:	TOTAL SHEETS
1			3			S3-31
2			4			33

DRAWN BY: H. T. BARBOUR DATE: 3-6-17
 CHECKED BY: A. SORSENGINH DATE: 3-17
 DESIGN ENGINEER OF RECORD: H.A. LOCKLEAR DATE: 6/2017

DOCUMENT NOT CONSIDERED
 FINAL UNLESS ALL
 SIGNATURES COMPLETED

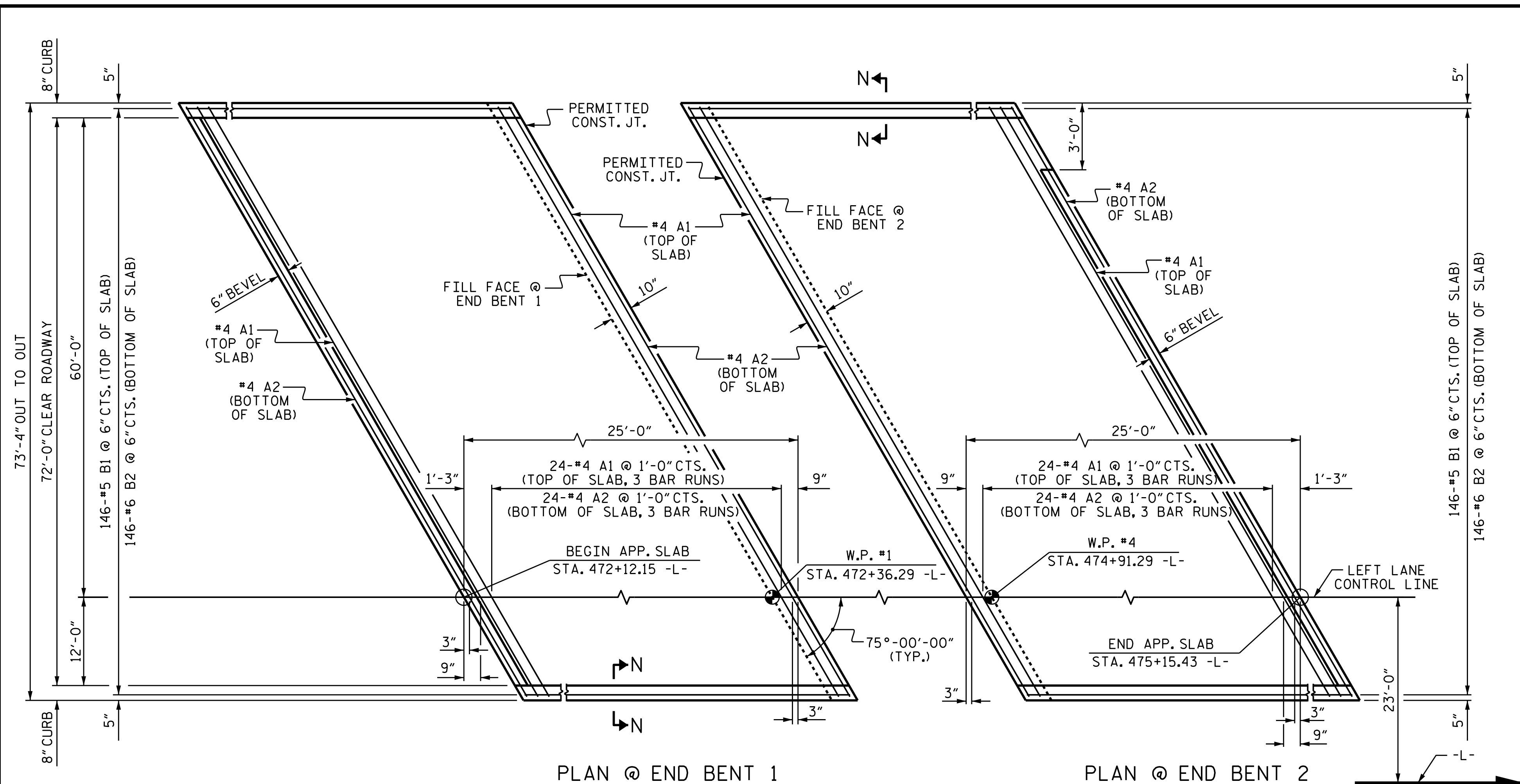

PLAN @ END BENT 1
 PLAN @ END BENT 2
 DIMENSIONS SHOWN ARE TYPICAL FOR BOTH APPROACH SLABS

NOTES

THE APPROACH SLAB MAY BE CAST MONOLITHICALLY WITH THE END BENT DIAPHRAGM AND THE END SECTION OF THE BRIDGE DECK NEAR THE INTEGRAL END BENT.

FOR REINFORCED BRIDGE APPROACH FILL FABRIC WALL INCLUDING GEOTEXTILE, IMPERMEABLE GEOMEMBRANE, 4" Ø DRAINAGE PIPE, #78M STONE, WELDED WIRE FORM, AND SELECT MATERIAL, SEE ROADWAY PLANS.

AREA BETWEEN THE WINGWALL AND APPROACH SLAB SHALL BE GRADED TO DRAIN THE WATER AWAY FROM THE FILL FACE OF THE BRIDGE AND SHALL BE PAVED. SEE ROADWAY PLANS.

THE JOINT OPENING AT THE APPROACH SLAB/DECK INTERFACE SHALL BE SAWS NO MORE THAN 12 HOURS AFTER THE APPROACH SLAB IS CAST. THE JOINT SHALL BE CLEANED OF ALL DEBRIS BEFORE THE SEALANT IS APPLIED. THE JOINT SEALER MATERIAL SHALL CONFORM TO THE REQUIREMENTS OF SECTION 1028-3 OF THE STANDARD SPECIFICATIONS.

BILL OF MATERIAL
 FOR ONE APPROACH SLAB
 (2 REQ'D)

BAR	NO.	SIZE	TYPE	LENGTH	WEIGHT
* A1	78	#4	STR	26'-6"	1381
A2	78	#4	STR	26'-4"	1372
* B1	146	#5	STR	24'-2"	3680
B2	146	#6	STR	24'-7"	5391
REINFORCING STEEL				6763 LBS.	
* EPOXY COATED REINFORCING STEEL				5061 LBS.	
CLASS AA CONCRETE				79.1 C. Y.	

SPLICE LENGTH

BAR SIZE	EPOXY COATED	UNCOATED
#4	2'-0"	1'-9"
#5	2'-6"	2'-2"
#6	3'-10"	2'-7"

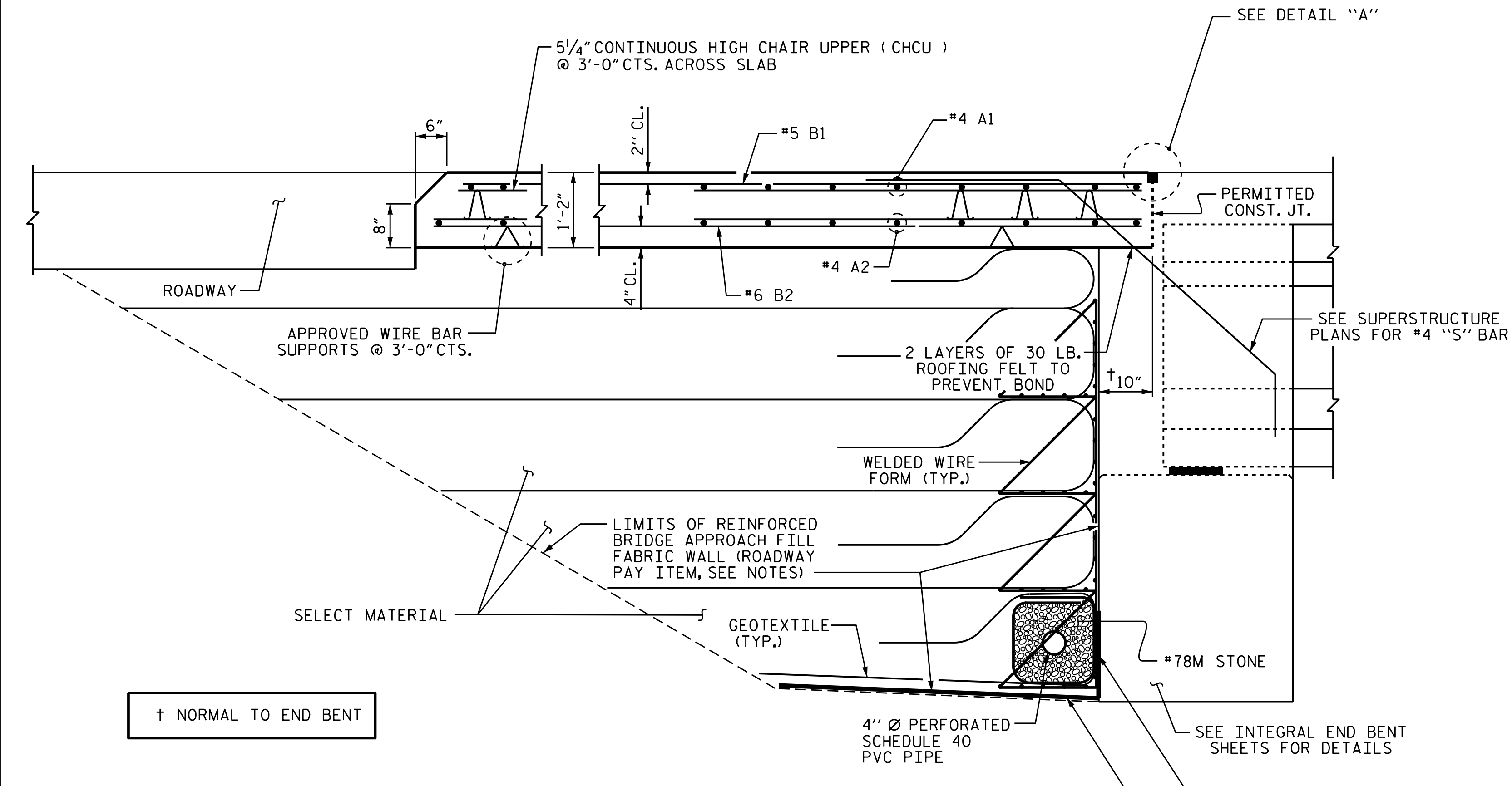

SECTION THRU SLAB

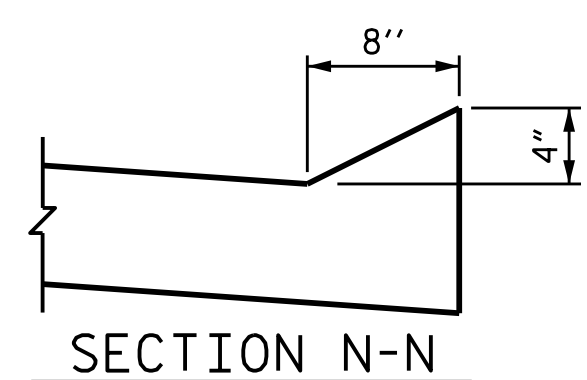
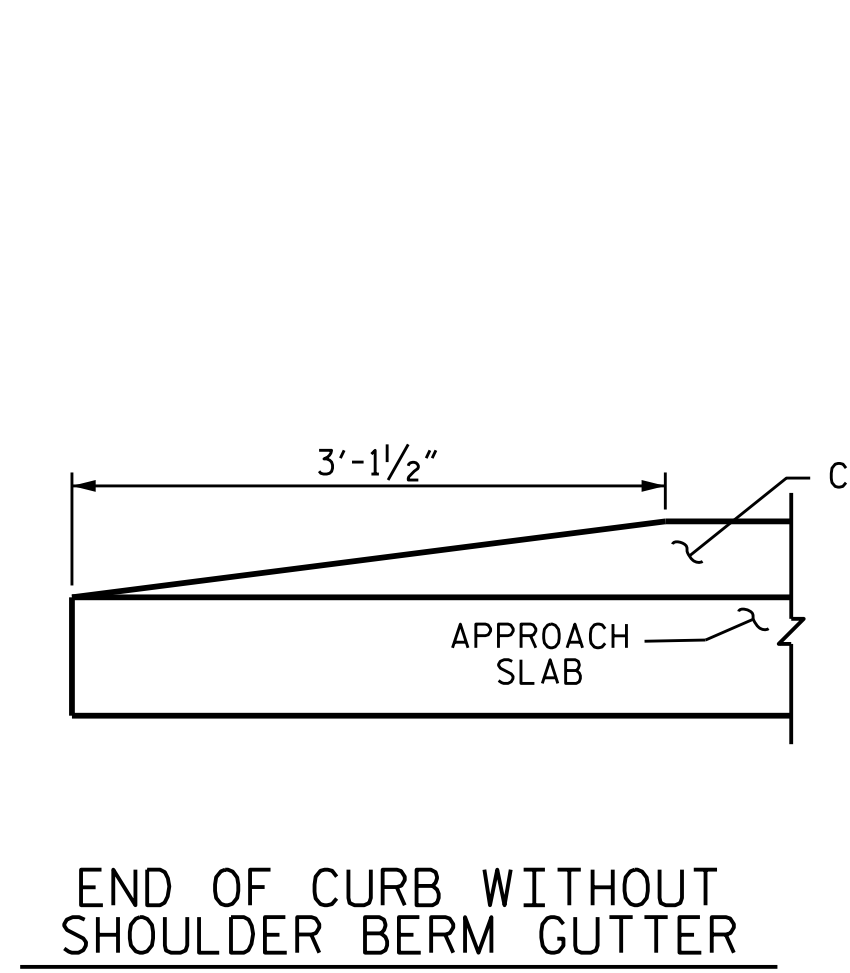
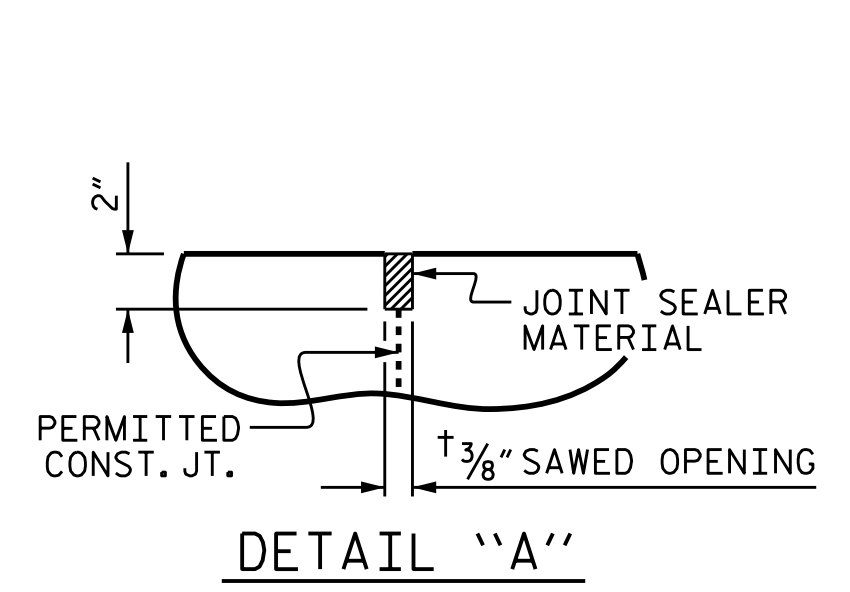

PROJECT NO. U-2579C
 FORSYTH COUNTY
 STATION: 473+70.00 -L-

SHEET 1 OF 2

STATE OF NORTH CAROLINA
 DEPARTMENT OF TRANSPORTATION
 RALEIGH
 STANDARD
 BRIDGE APPROACH SLAB
 FOR INTEGRAL ABUTMENT
 (LEFT LANE)

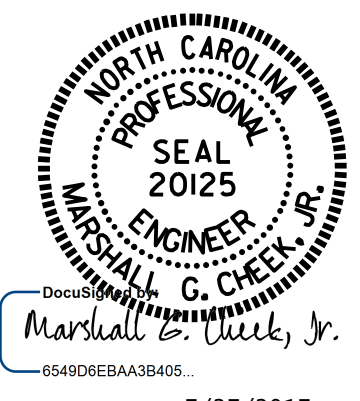

ASSEMBLED BY :	H. T. BARBOUR	DATE :	4-19-17
CHECKED BY :	T. L. AVERETTE	DATE :	4-20-17
DRAWN BY :	TLA	REV. 10/1/11	MAA/GM
CHECKED BY :	GM	REV. 12/21/11	MAA/GM
		REV. 6/13	MAA/GM

DOCUMENT NOT CONSIDERED
 FINAL UNLESS ALL
 SIGNATURES COMPLETED

REVISIONS						SHEET NO.
NO.	BY:	DATE:	NO.	BY:	DATE:	S3-32
1			3			TOTAL SHEETS
2			4			33

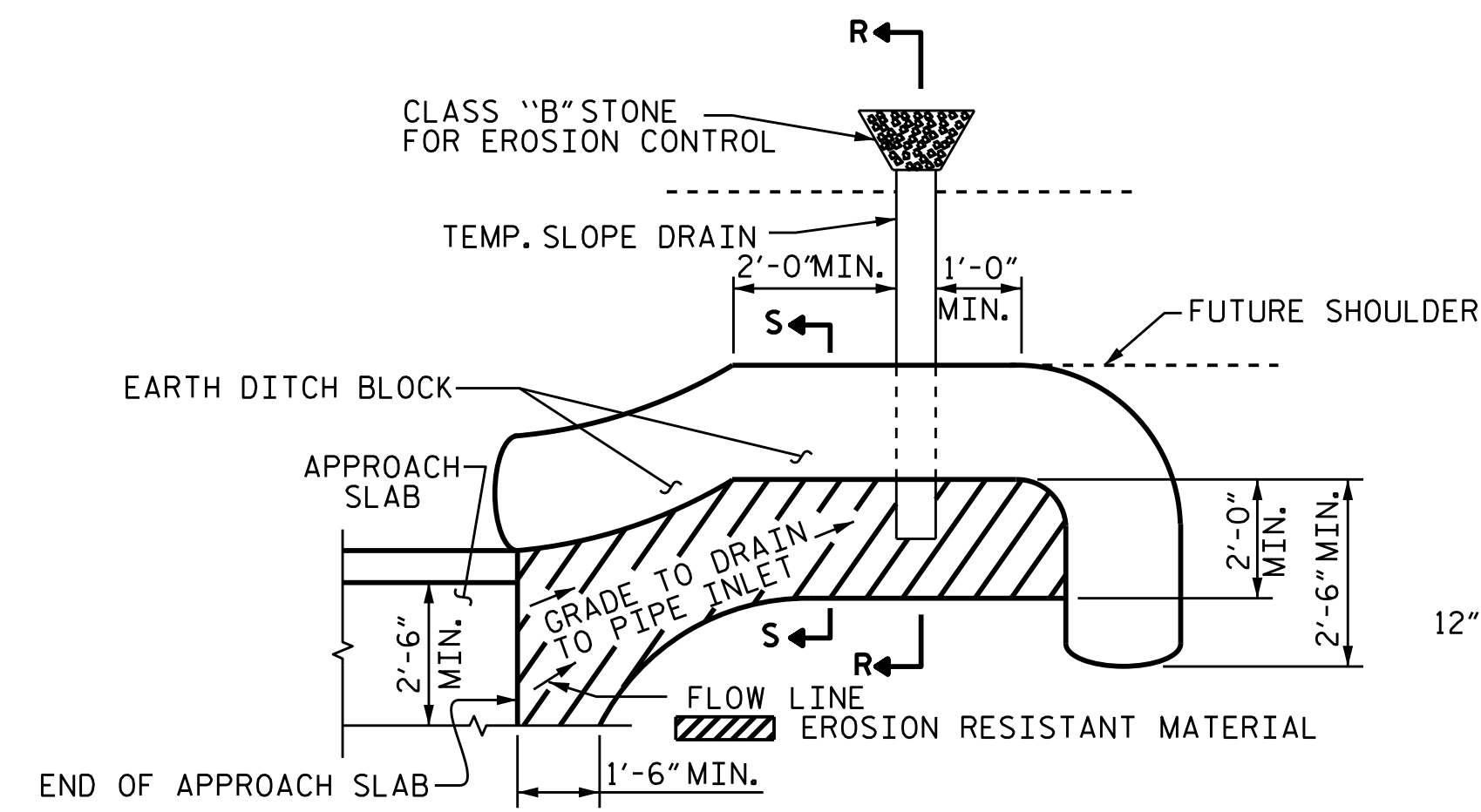

NOTE: IMMEDIATELY AFTER THE CONSTRUCTION OF THE APPROACH SLAB, THE CONTRACTOR SHALL PROVIDE TEMPORARY BERM AND SLOPE DRAIN. CONTRACTOR SHALL GRADE TO PIPE INLET AND PROVIDE EROSION RESISTANT MATERIAL AS SHOWN. THE EROSION RESISTANT MATERIAL SHALL BE EITHER 1) ASPHALT PLANT MIX, TYPE 1 OR TYPE 2, MIN. 2" DEPTH, 2) EROSION CONTROL MAT, OR 3) CONCRETE, AS DIRECTED BY THE ENGINEER. THE SLOPE DRAIN SHALL CONSIST OF A NON-PERFORATED TEMPORARY DRAINAGE PIPE, 12 INCHES IN DIAMETER.

PLAN VIEW

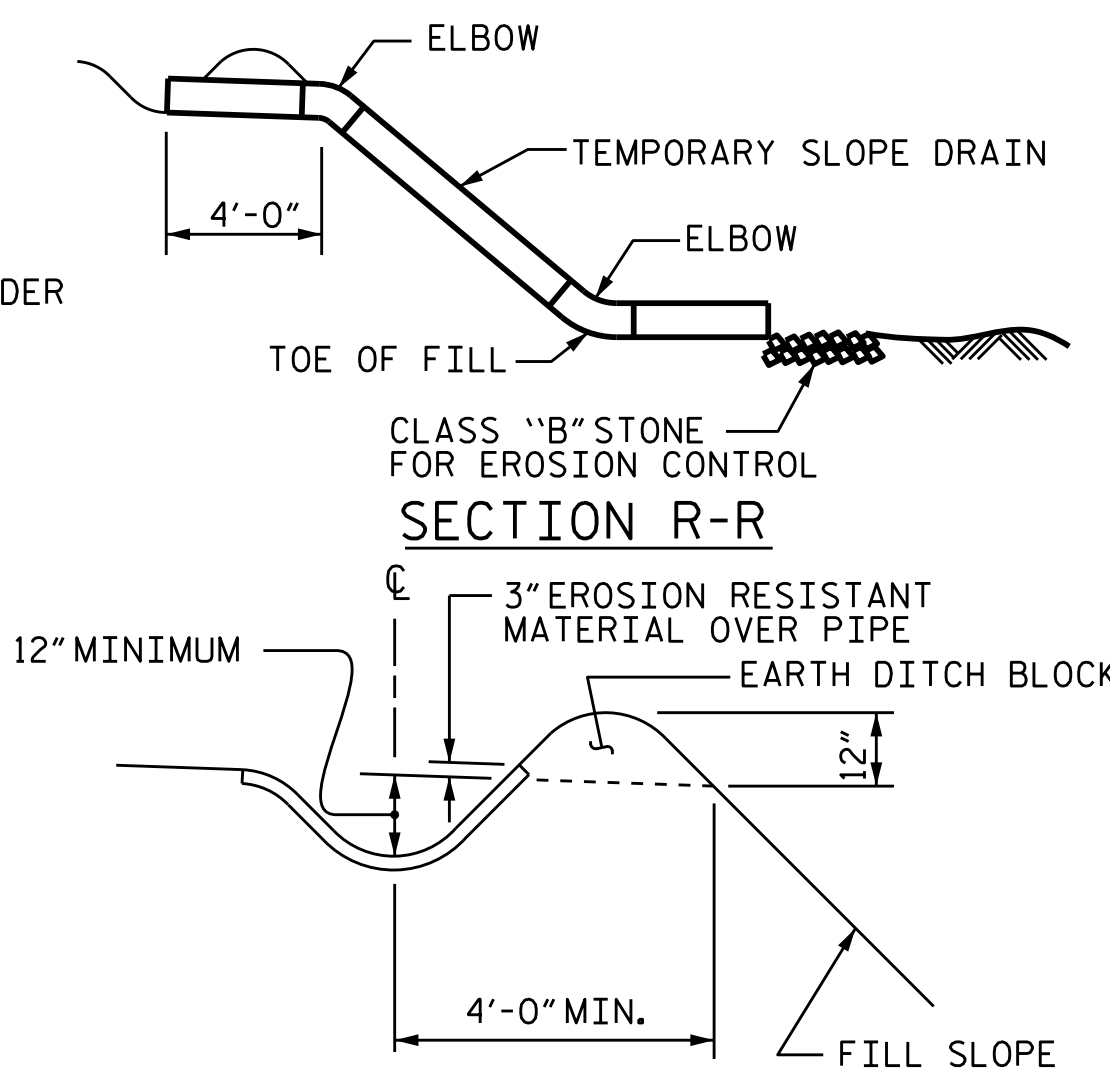

SECTION S-S

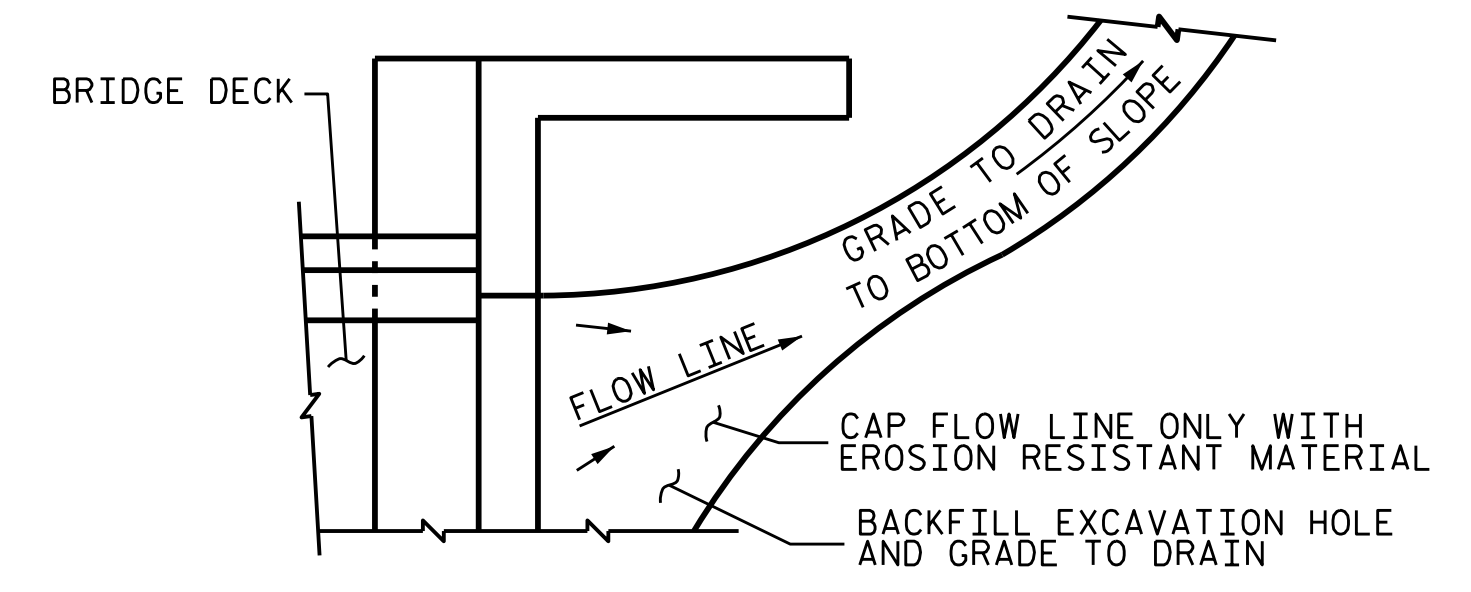

NOTE: IF THE APPROACH SLAB IS NOT CONSTRUCTED IMMEDIATELY AFTER THE BACKFILLING OF THE END BENT EXCAVATION, GRADE TO DRAIN TO THE BOTTOM OF THE SLOPE AND PROVIDE EROSION RESISTANT MATERIAL, SUCH AS FIBERGLASS ROVING OR AS DIRECTED BY THE ENGINEER TO PREVENT SOIL EROSION AND TO PROTECT THE AREA ADJACENT TO THE STRUCTURE. THE CONTRACTOR WILL BE REQUIRED TO REMOVE THESE MATERIALS PRIOR TO CONSTRUCTION OF THE APPROACH SLAB.

TEMPORARY DRAINAGE DETAIL

TEMPORARY BERM AND SLOPE DRAIN DETAILS
(TO BE USED WHEN SHOULDER BERM GUTTER IS REQUIRED)

PROJECT NO. U-2579C
FORSYTH COUNTY
STATION: 473+70.00 -L-

SHEET 2 OF 2

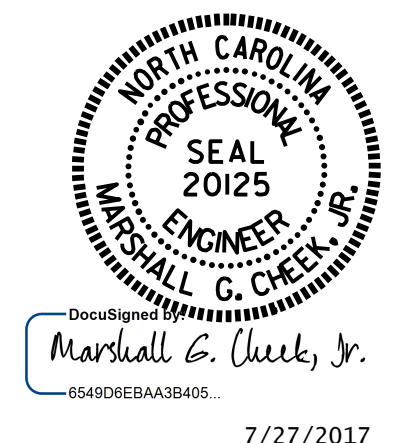

STATE OF NORTH CAROLINA
DEPARTMENT OF TRANSPORTATION
RALEIGH
STANDARD
BRIDGE APPROACH SLAB
FOR INTEGRAL ABUTMENT
DETAILS
(LEFT LANE)

DRAWN BY : H. T. BARBOUR DATE : 4-19-17
CHECKED BY : T. L. AVERETTE DATE : 4-20-17

DOCUMENT NOT CONSIDERED
FINAL UNLESS ALL
SIGNATURES COMPLETED

REVISIONS						SHEET NO.	
NO.	BY:	DATE:	NO.	BY:	DATE:	S3-33	
1			3			TOTAL SHEETS	
2			4			33	

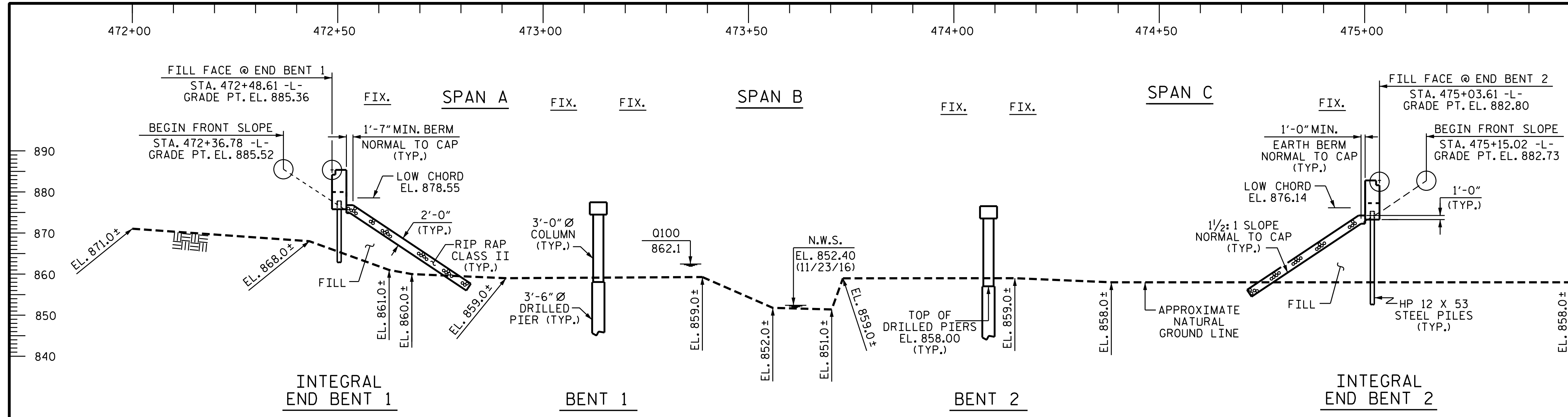

GRADE DATA
 (-)1.5597% (+)1.3500%
 PI STA. = 477+00.00 -L-
 EL = 878.24
 L = 1,050'

SECTION ALONG RIGHT LANE CONTROL LINE
 SECTIONS AT END BENTS AND BENTS ARE TAKEN AT RIGHT ANGLES

I HEREBY CERTIFY THESE PLANS ARE THE AS-BUILT PLANS

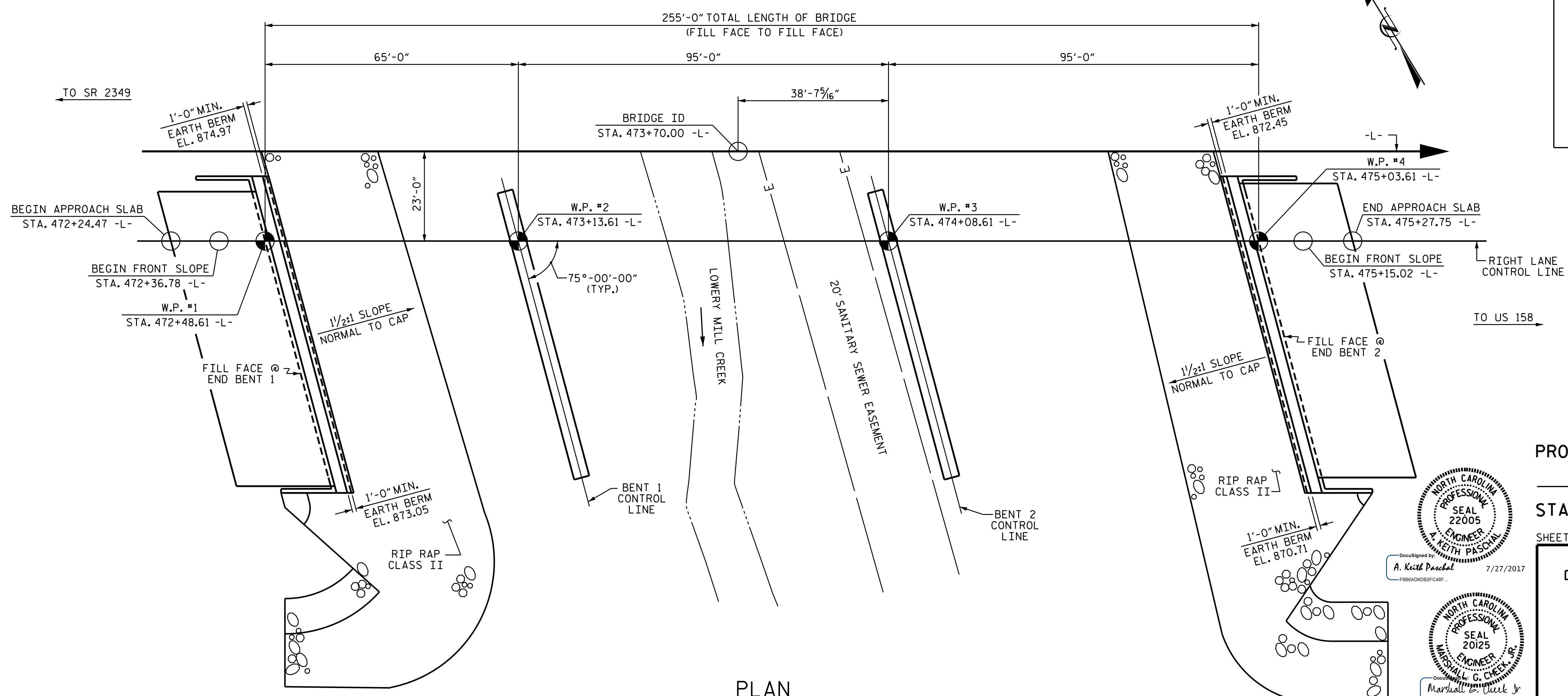

PLAN
 PILES, COLUMNS, AND DRILLED PIERS ARE NOT SHOWN FOR CLARITY.

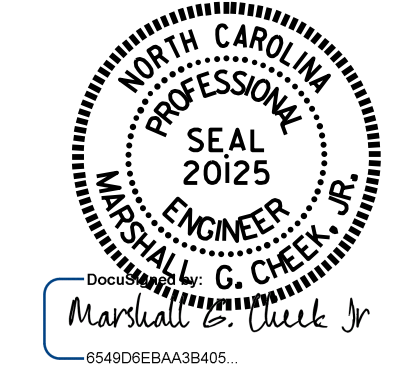
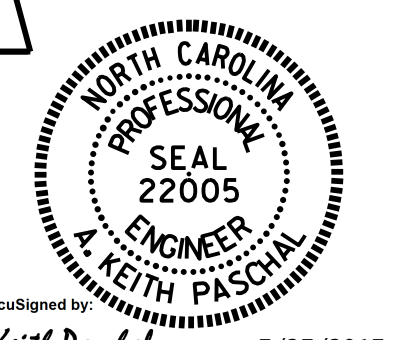

PROJECT NO. U-2579C
 FORSYTH COUNTY
 STATION: 473+70.00 -L-
 SHEET 1 OF 3 BRIDGE NO. 703

STATE OF NORTH CAROLINA
 DEPARTMENT OF TRANSPORTATION
 RALEIGH
GENERAL DRAWING
 FOR BRIDGE OVER
 LOWERY MILL CREEK
 ON WINSTON-SALEM BELTWAY
 BETWEEN SR 2381 AND US 158
 (RIGHT LANE)

DRAWN BY : M.K. BEARD DATE : 9/26/16
 CHECKED BY : H.T. BARBOUR DATE : 3/23/17
 DESIGN ENGINEER OF RECORD : H.A. LOCKLEAR DATE : 6/2017

DOCUMENT NOT CONSIDERED FINAL UNLESS ALL SIGNATURES COMPLETED

REVISIONS						SHEET NO.	
NO.	BY:	DATE:	NO.	BY:	DATE:	S4-1	
1			3			TOTAL SHEETS 33	
2			4				

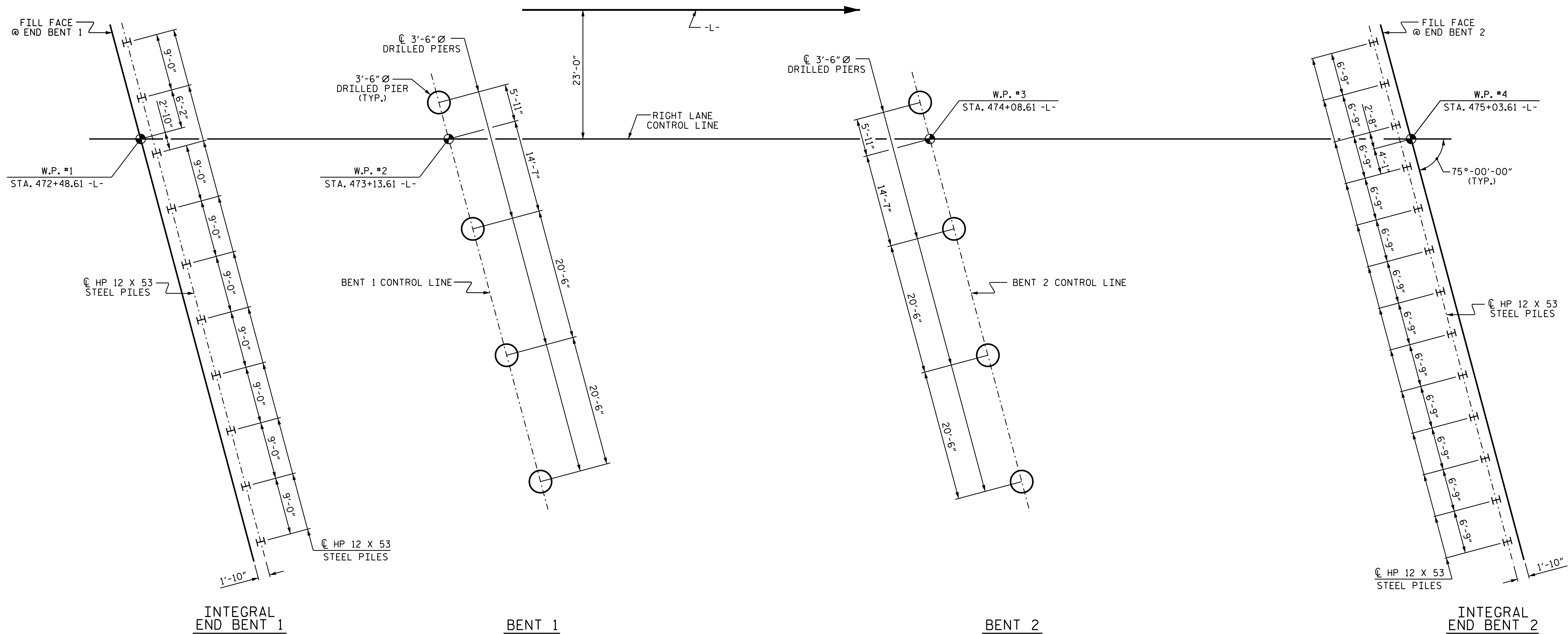

FOUNDATION LAYOUT

DIMENSIONS LOCATING PILES AND DRILLED PIERS ARE SHOWN TO THE CENTERLINE OF PILES AND DRILLED PIERS

NOTES

- FOR PILES, SEE GEOTECHNICAL SPECIAL PROVISIONS AND SECTION 450 OF THE STANDARD SPECIFICATIONS.
- PILES AT END BENT 1 ARE DESIGNED FOR A FACTORED RESISTANCE OF 120 TONS PER PILE.
- DRIVE PILES AT END BENT 1 TO A REQUIRED DRIVING RESISTANCE OF 200 TONS PER PILE.
- PILES AT END BENT 2 ARE DESIGNED FOR A FACTORED RESISTANCE OF 105 TONS PER PILE.
- DRIVE PILES AT END BENT 2 TO A REQUIRED DRIVING RESISTANCE OF 175 TONS PER PILE.
- DO NOT BEGIN WORK AT END BENT 1 AND END BENT 2 UNTIL FILL HAS BEEN PLACED.
- TESTING PILES WITH THE PDA DURING DRIVING, RESTRIKING OR REDRIVING MAY BE REQUIRED. THE ENGINEER WILL DETERMINE THE NEED FOR PDA TESTING. FOR PDA TESTING, SEE SECTION 450 OF THE STANDARD SPECIFICATIONS.
- SEE ROADWAY PLANS AND SPECIAL PROVISIONS FOR THE SETTLEMENT GAUGES REQUIRED AT END BENT 2.
- OBSERVE A 4 MONTH WAITING PERIOD AFTER CONSTRUCTING THE EMBANKMENTS TO WITHIN 2 FT. OF FINISHED GRADE BEFORE BEGINNING END BENT CONSTRUCTION AT END BENT 2. FOR BRIDGE WAITING PERIODS, SEE ROADWAY PLANS AND SPECIAL PROVISIONS.
- FOR DRILLED PIERS, SEE GEOTECHNICAL SPECIAL PROVISIONS AND SECTION 411 OF THE STANDARD SPECIFICATIONS.
- DRILLED PIERS AT BENT 1 ARE DESIGNED FOR A FACTORED RESISTANCE OF 610 TONS PER PIER.

- PERMANENT STEEL CASINGS MAY BE REQUIRED FOR DRILLED PIERS AT BENT 1 AND BENT 2. IF REQUIRED, DO NOT EXTEND PERMANENT CASINGS BELOW ELEVATION 850.00 WITHOUT PRIOR APPROVAL FROM THE ENGINEER. THE ENGINEER WILL DETERMINE THE NEED FOR PERMANENT CASINGS.
- INSTALL DRILLED PIERS AT BENT 1 TO A TIP ELEVATION NO HIGHER THAN 798.00 AND WITH A PENETRATION OF AT LEAST 17.5 FT. INTO WEATHERED ROCK/CRYSTALLINE ROCK.
- DRILLED PIERS AT BENT 2 ARE DESIGNED FOR A FACTORED RESISTANCE OF 700 TONS PER PIER.
- INSTALL DRILLED PIERS AT BENT 2 TO A TIP ELEVATION NO HIGHER THAN 812.00 (LT) AND 809.00 (RT) AND WITH A PENETRATION OF AT LEAST 22.5 FT. INTO WEATHERED ROCK/CRYSTALLINE ROCK.
- SLURRY CONSTRUCTION IS REQUIRED FOR DRILLED PIERS AT BENT 1 AND BENT 2.
- SPT IS REQUIRED FOR DRILLED PIERS AT BENT 1 AND BENT 2. THE REQUIRED N60 SPT VALUE IS 100 BLOWS IN THE FIRST FOOT OF THE DRIVE. FOR SPT TESTING, SEE SECTION 411 OF THE STANDARD SPECIFICATIONS.
- SID INSPECTIONS MAY BE REQUIRED FOR DRILLED PIERS. THE ENGINEER WILL DETERMINE THE NEED FOR SID INSPECTIONS. FOR SID INSPECTIONS, SEE SECTION 411 OF THE STANDARD SPECIFICATIONS.
- CSL TUBES ARE REQUIRED AND CSL TESTING MAY BE REQUIRED FOR DRILLED PIERS. THE ENGINEER WILL DETERMINE THE NEED FOR CSL TESTING. FOR CSL TESTING, SEE SECTION 411 OF THE STANDARD SPECIFICATIONS.
- THE SCOUR CRITICAL ELEVATION FOR BENT 1 AND BENT 2 IS ELEVATION 845.00. SCOUR CRITICAL ELEVATIONS ARE USED TO MONITOR POSSIBLE SCOUR PROBLEMS DURING THE LIFE OF THE STRUCTURE.

PROJECT NO. U-2579C
FORSYTH COUNTY
 STATION: 473+70.00 -L-

SHEET 2 OF 3

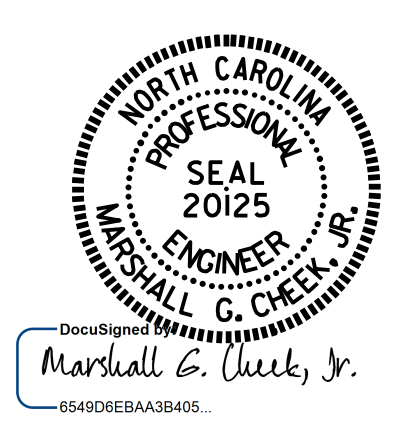

STATE OF NORTH CAROLINA
 DEPARTMENT OF TRANSPORTATION
 RALEIGH
GENERAL DRAWING
 FOR BRIDGE OVER
 LOWERY MILL CREEK
 ON WINSTON-SALEM BELTWAY
 BETWEEN SR 2381 AND US 158
 (RIGHT LANE)

DRAWN BY : M.K. BEARD DATE : 9/26/16
 CHECKED BY : H.T. BARBOUR DATE : 3/23/17
 DESIGN ENGINEER OF RECORD: H.A. LOCKLEAR DATE : 6/2017

DOCUMENT NOT CONSIDERED
 FINAL UNLESS ALL
 SIGNATURES COMPLETED

REVISIONS						SHEET NO.
NO.	BY:	DATE:	NO.	BY:	DATE:	S4-2
1			3			TOTAL SHEETS
2			4			33

B.M. #8 : R/R SPIKE SET IN BASE OF 36" SWEET GUM AND 70' WEST OF CREEK BANK, 565' LEFT OF STA. 469+22.00 -L-, EL. 864.90

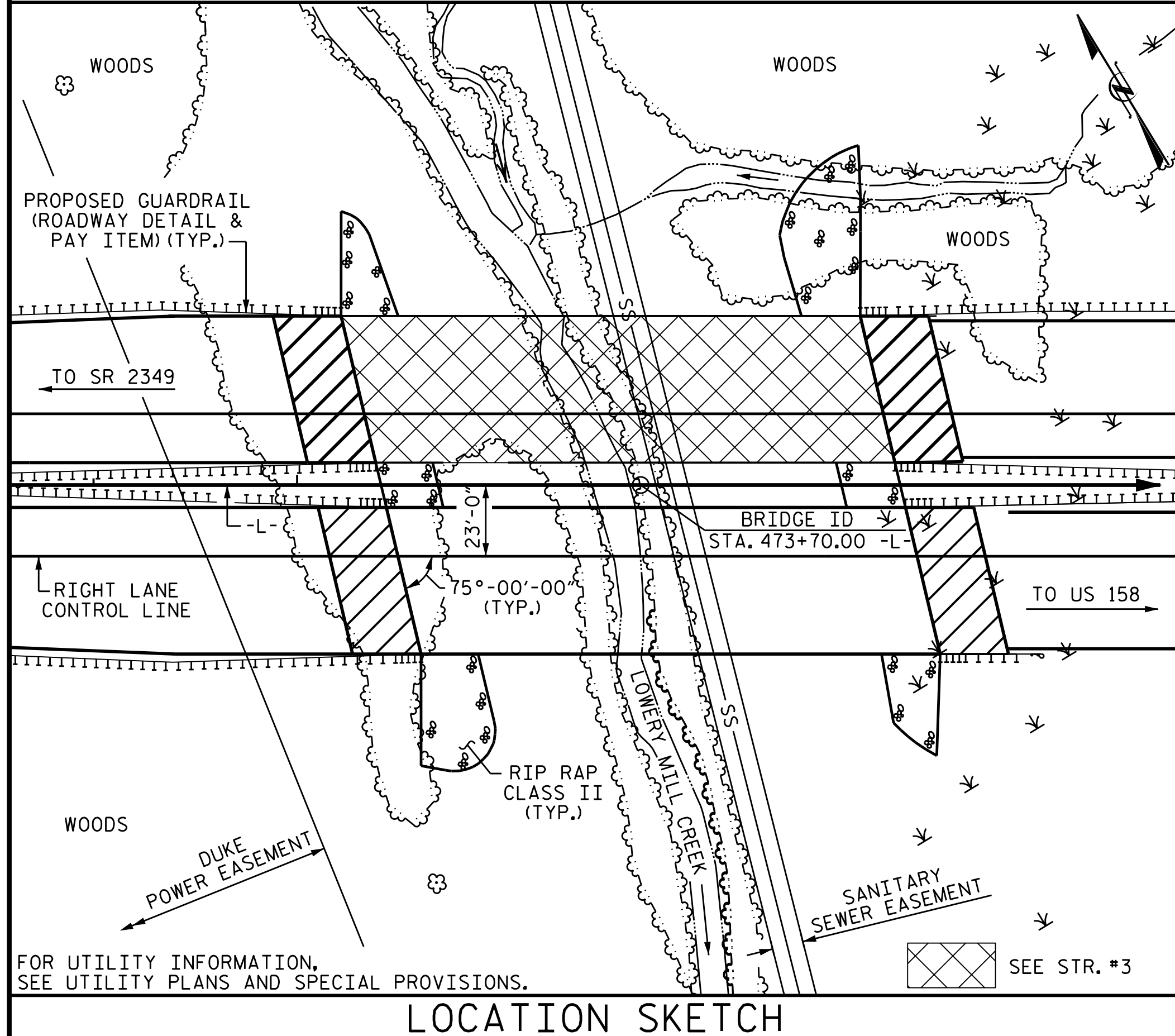

NOTES

ASSUMED LIVE LOAD = HL-93 OR ALTERNATE LOADING.

THIS BRIDGE HAS BEEN DESIGNED IN ACCORDANCE WITH THE AASHTO LRFD BRIDGE DESIGN SPECIFICATIONS.

THIS BRIDGE IS LOCATED IN SEISMIC ZONE 1.

FOR OTHER DESIGN DATA AND GENERAL NOTES, SEE SHEET SN.

FOR SUBMITTAL OF WORKING DRAWINGS, SEE SPECIAL PROVISIONS.

FOR FALSEWORK AND FORMWORK, SEE SPECIAL PROVISIONS.

FOR CRANE SAFETY, SEE SPECIAL PROVISIONS.

FOR GROUT FOR STRUCTURES, SEE SPECIAL PROVISIONS.

THE CONTRACTOR SHALL PROVIDE INDEPENDENT ASSURANCE SAMPLES OF REINFORCING STEEL AS FOLLOWS: FOR PROJECTS REQUIRING UP TO 400 TONS OF REINFORCING STEEL, ONE 30 INCH SAMPLE OF EACH SIZE BAR USED, AND FOR PROJECTS REQUIRING OVER 400 TONS OF REINFORCING STEEL, TWO 30 INCH SAMPLES OF EACH SIZE BAR USED. THE BARS FROM WHICH THE SAMPLES ARE TAKEN MUST THEN BE SPLICED WITH REPLACEMENT BARS OF THE SIZE AND LENGTH OF THE SAMPLE, PLUS A MINIMUM LAP SPLICE OF THIRTY BAR DIAMETERS. PAYMENT FOR THE SAMPLES OF REINFORCING STEEL SHALL BE CONSIDERED INCIDENTAL TO VARIOUS PAY ITEMS.

PRESTRESSED CONCRETE DECK PANELS MAY BE USED IN LIEU OF METAL STAY-IN-PLACE FORMS IN ACCORDANCE WITH ARTICLE 420-3 OF THE STANDARD SPECIFICATIONS.

REMOVABLE FORMS MAY BE USED IN LIEU OF METAL STAY-IN-PLACE FORMS IN ACCORDANCE WITH ARTICLE 420-3 OF THE STANDARD SPECIFICATIONS.

THIS STRUCTURE HAS BEEN DESIGNED IN ACCORDANCE WITH "HEC 18-EVALUATING SCOUR AT BRIDGES."

NEEDLE BEAMS WILL NOT BE ALLOWED UNLESS OTHERWISE CALLED FOR ON THE PLANS OR APPROVED BY THE ENGINEER.

THE CLASS AA CONCRETE IN THE BRIDGE DECK SHALL CONTAIN FLY ASH OR GROUND GRANULATED BLAST FURNACE SLAG AT THE SUBSTITUTION RATE SPECIFIED IN ARTICLE 1024-1 AND IN ACCORDANCE WITH ARTICLES 1024-5 AND 1024-6 OF THE STANDARD SPECIFICATIONS. NO PAYMENT WILL BE MADE FOR THIS SUBSTITUTION AS IT IS CONSIDERED INCIDENTAL TO THE COST OF THE REINFORCED CONCRETE DECK SLAB.

FOR EROSION CONTROL MEASURES, SEE EROSION CONTROL PLANS.

FOR PLACING LOAD ON STRUCTURE MEMBERS, SEE SPECIAL PROVISIONS.

FOR EMBEDDED CLIPS FOR PRESTRESSED CONCRETE GIRDERS, SEE SPECIAL PROVISIONS.

HYDRAULIC DATA

DESIGN DISCHARGE	= 1,900 C.F.S.
FREQUENCY OF DESIGN FLOOD	= 50 YRS.
DESIGN HIGH WATER ELEVATION	= 861.8
DRAINAGE AREA	= 2.4 SQ. MI.
BASE DISCHARGE (0100)	= 2,230 C.F.S.
BASE HIGH WATER ELEVATION	= 862.1

OVERTOPPING DATA

OVERTOPPING DISCHARGE	= 2,960+ C.F.S.
FREQUENCY OF OVERTOPPING FLOOD	= 500+ YRS.
OVERTOPPING FLOOD ELEVATION	= 882.0
SAG @ STA. 477+34.84 -L-	

TOTAL BILL OF MATERIAL

	3'-6" Ø DRILLED PIERS IN SOIL	3'-6" Ø DRILLED PIERS NOT IN SOIL	PERMANENT STEEL CASING FOR 3'-6" Ø DRILLED PIERS	PDA TESTING	SID INSPECTIONS	SPT TESTING	CSL TESTING	REINFORCED CONCRETE DECK SLAB	GROOVING BRIDGE FLOORS	CLASS A CONCRETE	BRIDGE APPROACH SLABS	REINFORCING STEEL	SPIRAL COLUMN REINFORCING STEEL	54" PRESTRESSED CONCRETE GIRDERS	PILE DRIVING EQUIPMENT SETUP FOR HP 12 X 53 STEEL PILES	HP 12 X 53 STEEL PILES	CONCRETE BARRIER RAIL	RIP RAP CLASS II (2'-0" THICK)	GEOTEXTILE FOR DRAINAGE	ELASTOMERIC BEARINGS		
	LIN. FT.	LIN. FT.	LIN. FT.	EA.	EA.	EA.	EA.	SO. FT.	SO. FT.	CU. YDS.	LUMP SUM	LBS.	LBS.	NO.	LIN. FT.	EA.	NO.	LIN. FT.	LIN. FT.	TONS	SO. YDS.	LUMP SUM
SUPERSTRUCTURE								19,189	20,783		LUMP SUM			27	2,258.63					506.55		LUMP SUM
INT. END BENT 1										59.4		6,474			10	10	650			470	520	
BENT 1	180.00	60.00	32.00			4				62.8		32,777	6,435									
BENT 2	122.00	68.00	32.00			4				66.8		28,459	5,271									
INT. END BENT 2										59.5		6,493			13	13	685			485	540	
TOTAL	302.00	128.00	64.00	1	1	8	1	19,189	20,783	248.5	LUMP SUM	74,203	11,706	27	2,258.63	23	23	1,335	506.55	955	1,060	LUMP SUM

PROJECT NO. U-2579C
 FORSYTH COUNTY
 STATION: 473+70.00 -L-

SHEET 3 OF 3

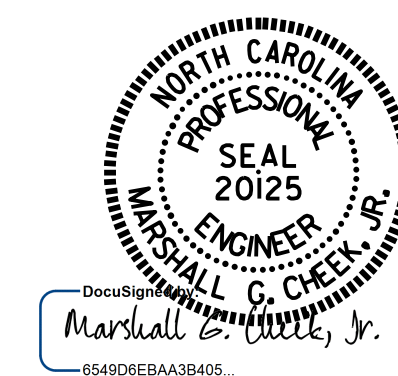

7/27/2017

STATE OF NORTH CAROLINA
 DEPARTMENT OF TRANSPORTATION
 RALEIGH
 GENERAL DRAWING
 FOR BRIDGE OVER
 LOWERY MILL CREEK
 ON WINSTON-SALEM BELTWAY
 BETWEEN SR 2381 AND US 158
 (RIGHT LANE)

DRAWN BY : M.K. BEARD DATE : 9/26/16
 CHECKED BY : H.T. BARBOUR DATE : 3/23/17
 DESIGN ENGINEER OF RECORD : H.A. LOCKLEAR DATE : 6/2017

DOCUMENT NOT CONSIDERED
 FINAL UNLESS ALL
 SIGNATURES COMPLETED

REVISIONS						SHEET NO.	
NO.	BY:	DATE:	NO.	BY:	DATE:	S4-3	
1			3			TOTAL SHEETS	
2			4			33	

LOAD FACTORS:

DESIGN LOAD RATING FACTORS	LIMIT STATE	γ_{DC}	γ_{DW}
	STRENGTH I	1.25	1.50
	SERVICE III	1.00	1.00

LOAD AND RESISTANCE FACTOR RATING (LRFD) SUMMARY FOR PRESTRESSED CONCRETE GIRDERS																								
LEVEL	VEHICLE	WEIGHT (W) (TONS)	CONTROLLING LOAD RATING #	MINIMUM RATING FACTORS (RF)	TONS = W X RF	STRENGTH I LIMIT STATE										SERVICE III LIMIT STATE								COMMENT NUMBER
						LIVELOAD FACTORS	MOMENT					SHEAR					LIVELOAD FACTORS	MOMENT						
							DISTRIBUTION FACTORS (DF)	RATING FACTOR	SPAN	GIRDER LOCATION	DISTANCE FROM LEFT END OF SPAN (ft)	DISTRIBUTION FACTORS (DF)	RATING FACTOR	SPAN	GIRDER LOCATION	DISTANCE FROM LEFT END OF SPAN (ft)		DISTRIBUTION FACTORS (DF)	RATING FACTOR	SPAN	GIRDER LOCATION	DISTANCE FROM LEFT END OF SPAN (ft)		
DESIGN LOAD RATING	HL-93(Inv)	N/A	①	1.01	--	1.75	0.776	1.02	A	ER	30.988	0.882	1.45	A	I	12.395	0.80	0.776	1.01	B	ER	46.375		
	HL-93(0pr)	N/A	--	1.32	--	1.35	0.776	1.33	A	ER	30.988	0.882	1.88	A	I	12.395	N/A	--	--	--	--	--		
	HS-20(Inv)	36.000	②	1.30	46.860	1.75	0.776	1.31	A	ER	30.988	0.882	1.76	A	I	12.395	0.80	0.776	1.31	A	ER	30.988		
	HS-20(0pr)	36.000	--	1.69	60.745	1.35	0.776	1.69	A	ER	30.988	0.882	2.28	A	I	12.395	N/A	--	--	--	--	--		
LEGAL LOAD RATING	SV	SH	12.500	--	3.13	39.167	1.40	0.776	3.87	A	ER	30.988	0.882	5.45	A	I	12.395	0.80	0.776	3.11	A	ER	30.988	
		S3C	21.500	--	1.84	39.512	1.40	0.776	2.27	A	ER	30.988	0.882	3.22	A	I	12.395	0.80	0.776	1.83	A	ER	30.988	
		S3A	22.750	--	1.74	39.665	1.40	0.776	2.15	A	ER	30.988	0.882	3.06	A	I	12.395	0.80	0.776	1.73	A	ER	30.988	
		S4A	26.750	--	1.56	41.702	1.40	0.776	1.92	A	ER	30.988	0.882	2.72	A	I	12.395	0.80	0.776	1.55	A	ER	30.988	
		S5A	30.500	--	1.38	42.110	1.40	0.776	1.70	A	ER	30.988	0.882	2.56	A	I	12.395	0.80	0.776	1.37	A	ER	30.988	
		S6A	34.500	--	1.27	43.734	1.40	0.776	1.57	A	ER	30.988	0.882	2.34	A	I	12.395	0.80	0.776	1.26	A	ER	30.988	
	TTST	S7B	38.500	③	1.16	44.764	1.40	0.776	1.44	A	ER	30.988	0.882	2.25	A	I	12.395	0.80	0.776	1.16	A	ER	30.988	
		S7A	40.000	--	1.17	46.590	1.40	0.776	1.44	A	ER	30.988	0.882	2.37	A	I	12.395	0.80	0.776	1.16	A	ER	30.988	
		T4A	28.250	--	1.57	44.261	1.40	0.776	1.93	A	ER	30.988	0.882	2.67	A	I	12.395	0.80	0.776	1.56	A	ER	30.988	
		T5B	32.000	--	1.37	43.935	1.40	0.776	1.70	A	ER	30.988	0.882	2.59	A	I	12.395	0.80	0.776	1.36	A	ER	30.988	
		T6A	36.000	--	1.28	46.024	1.40	0.776	1.58	A	ER	30.988	0.882	2.50	A	I	12.395	0.80	0.776	1.27	A	ER	30.988	
		T7A	40.000	--	1.21	48.183	1.40	0.776	1.49	A	ER	30.988	0.882	2.40	A	I	12.395	0.80	0.776	1.20	A	ER	30.988	
	T7B	40.000	--	1.33	53.333	1.40	0.776	1.65	A	ER	30.988	0.882	2.16	A	I	12.395	0.80	0.776	1.32	A	ER	30.988		

NOTES:

MINIMUM RATING FACTORS ARE BASED ON THE STRENGTH I AND SERVICE III LIMIT STATES.
ALLOWABLE STRESSES FOR SERVICE III LIMIT STATE ARE AS REQUIRED FOR DESIGN.

③ CONTROLLING LOAD RATING

① DESIGN LOAD RATING (HL-93)

② DESIGN LOAD RATING (HS-20)

③ LEGAL LOAD RATING **

** SEE CHART FOR VEHICLE TYPE

GIRDER LOCATION

I - INTERIOR GIRDER
EL - EXTERIOR LEFT GIRDER
ER - EXTERIOR RIGHT GIRDER

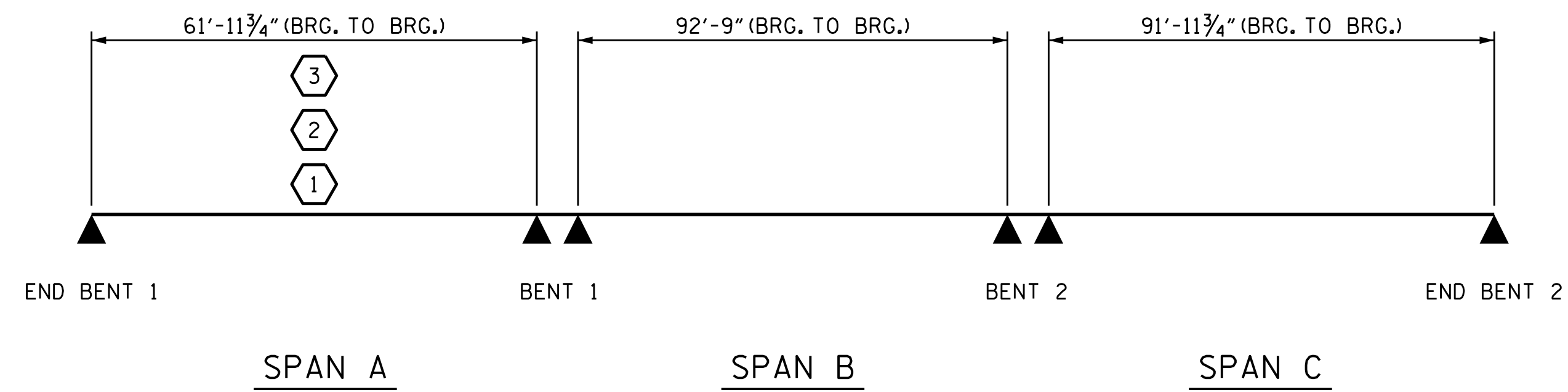

LRFR SUMMARY

PROJECT NO. U-2579C
FORSYTH COUNTY
STATION: 473+70.00 -L-



STATE OF NORTH CAROLINA
DEPARTMENT OF TRANSPORTATION
RALEIGH
STANDARD
LRFR SUMMARY FOR
PRESTRESSED
CONCRETE GIRDERS
(INTERSTATE TRAFFIC)

ASSEMBLED BY : T. L. AVERETTE	DATE : 3/13/17
CHECKED BY : H. T. BARBOUR	DATE : 3/14/17
DRAWN BY : MAA	1/08
CHECKED BY : GM/DI	2/08
REV. 11/12/08RR	MAA/GM
REV. 10/1/11	MAA/GM

DOCUMENT NOT CONSIDERED FINAL UNLESS ALL SIGNATURES COMPLETED	NO.	BY:	DATE:	NO.	BY:	DATE:	SHEET NO.
	1			3			S4-4
	2			4			TOTAL SHEETS 33

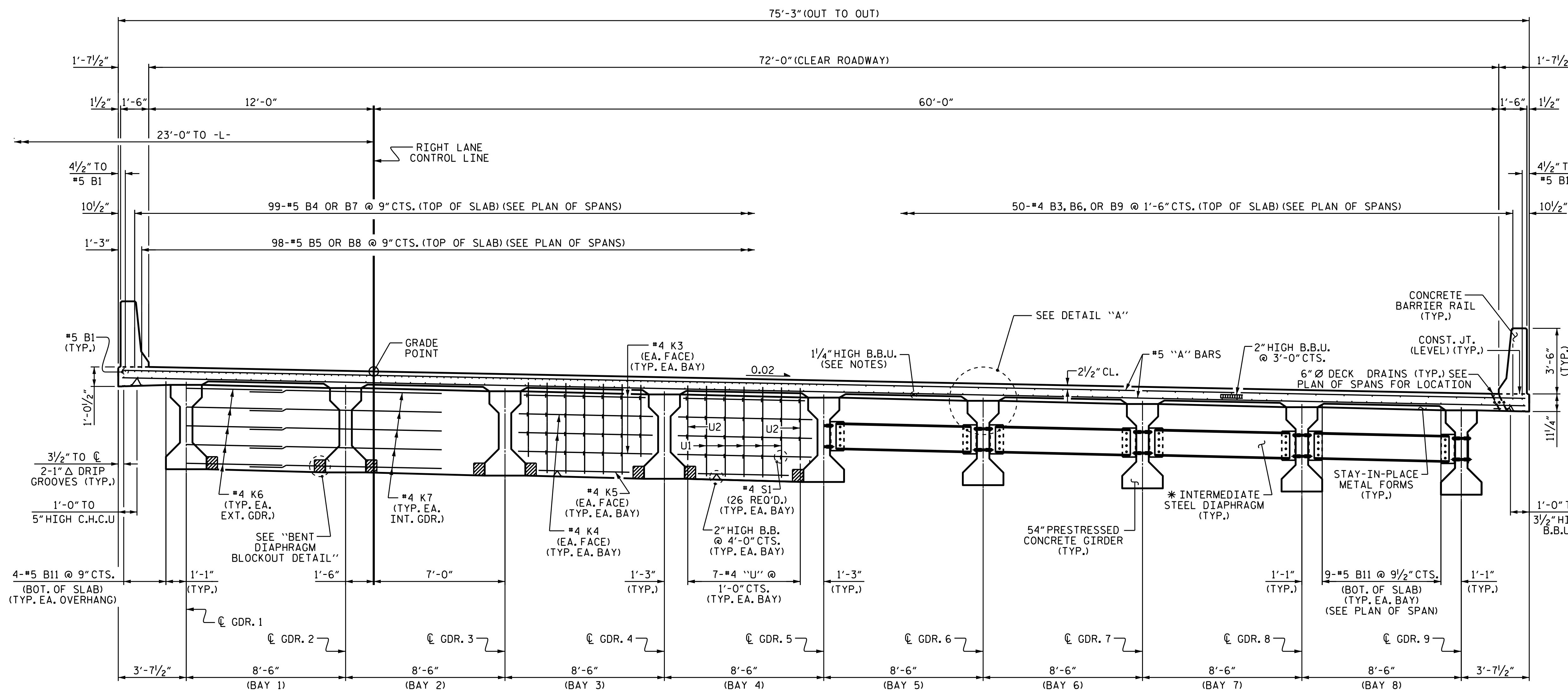

TYPICAL SECTION
(SHOWING BENT DIAPHRAGMS)

TYPICAL SECTION
(SHOWING INTERMEDIATE DIAPHRAGMS)

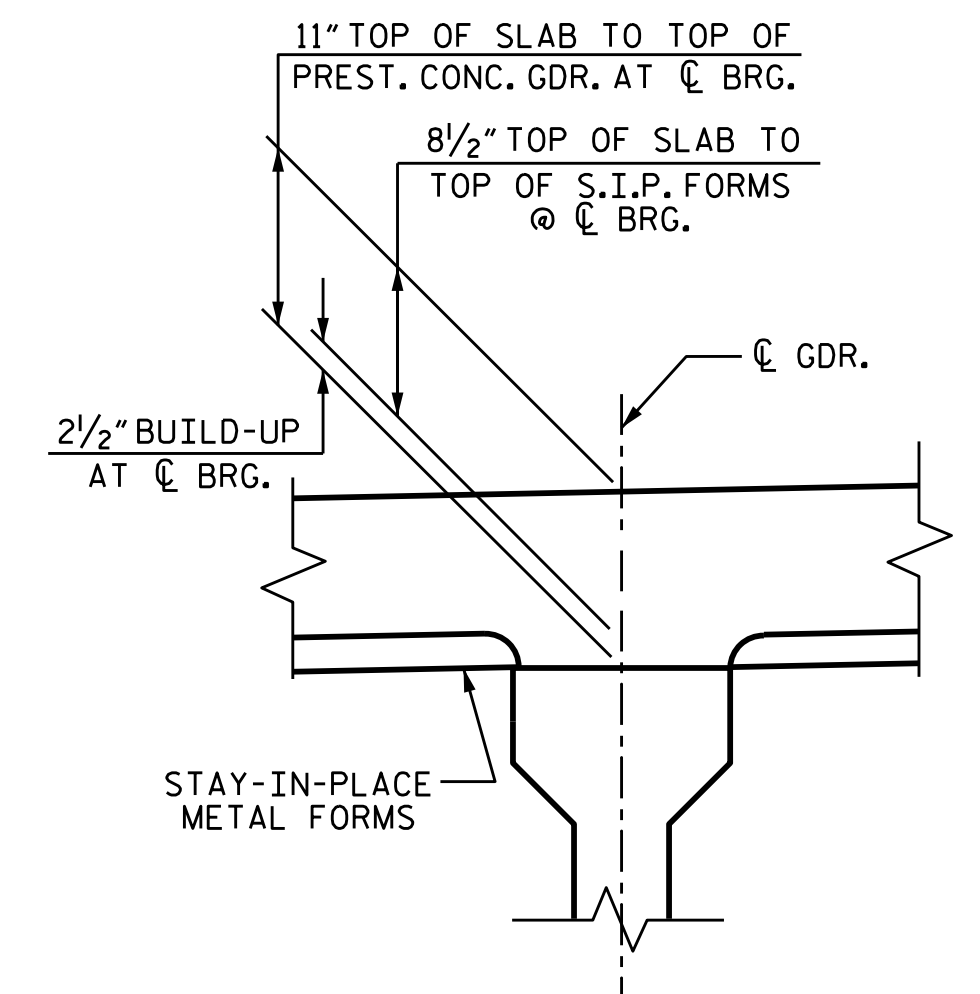

DETAIL "A"

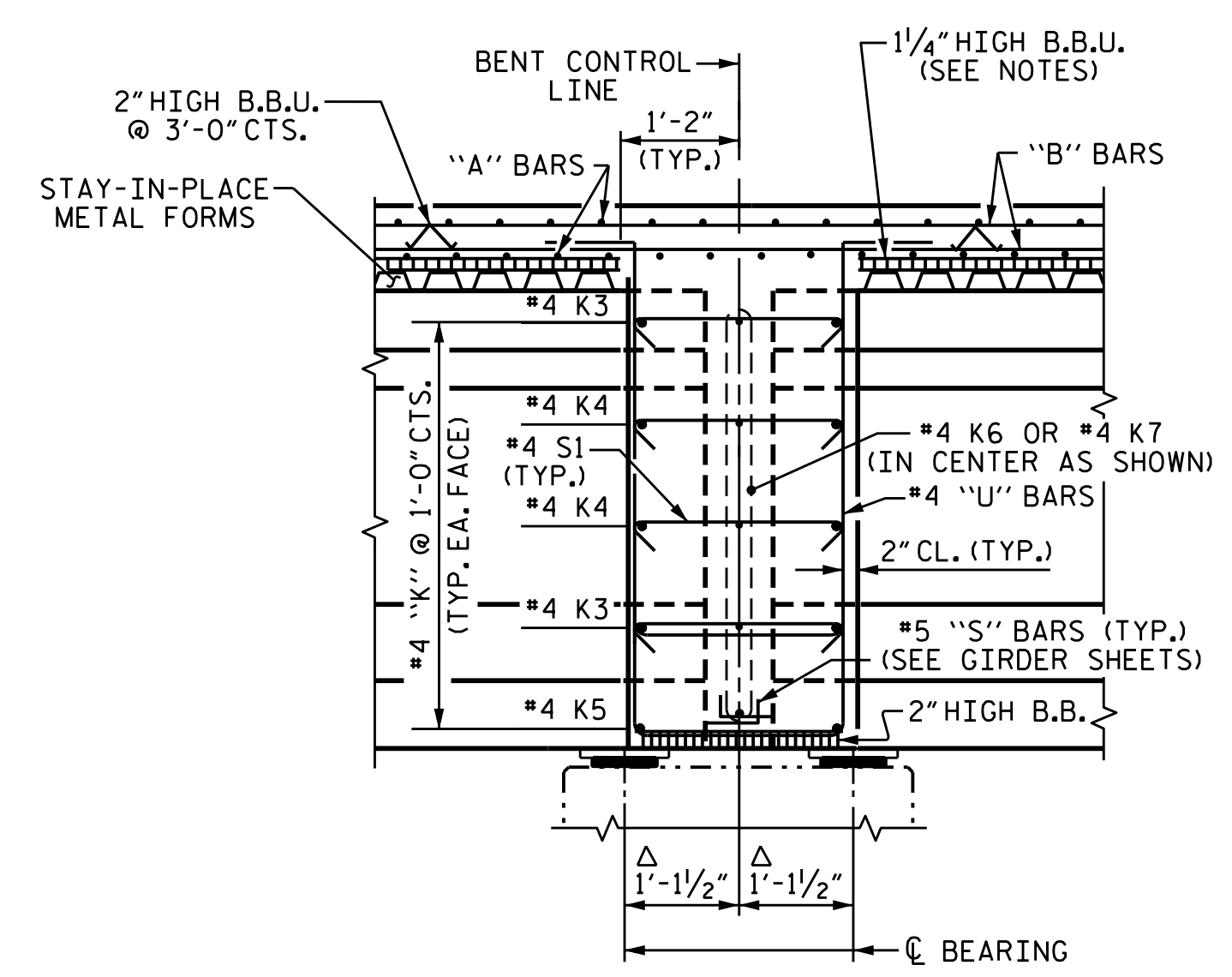

SECTION THROUGH BENT DIAPHRAGM

Δ MEASURED ALONG GDR.

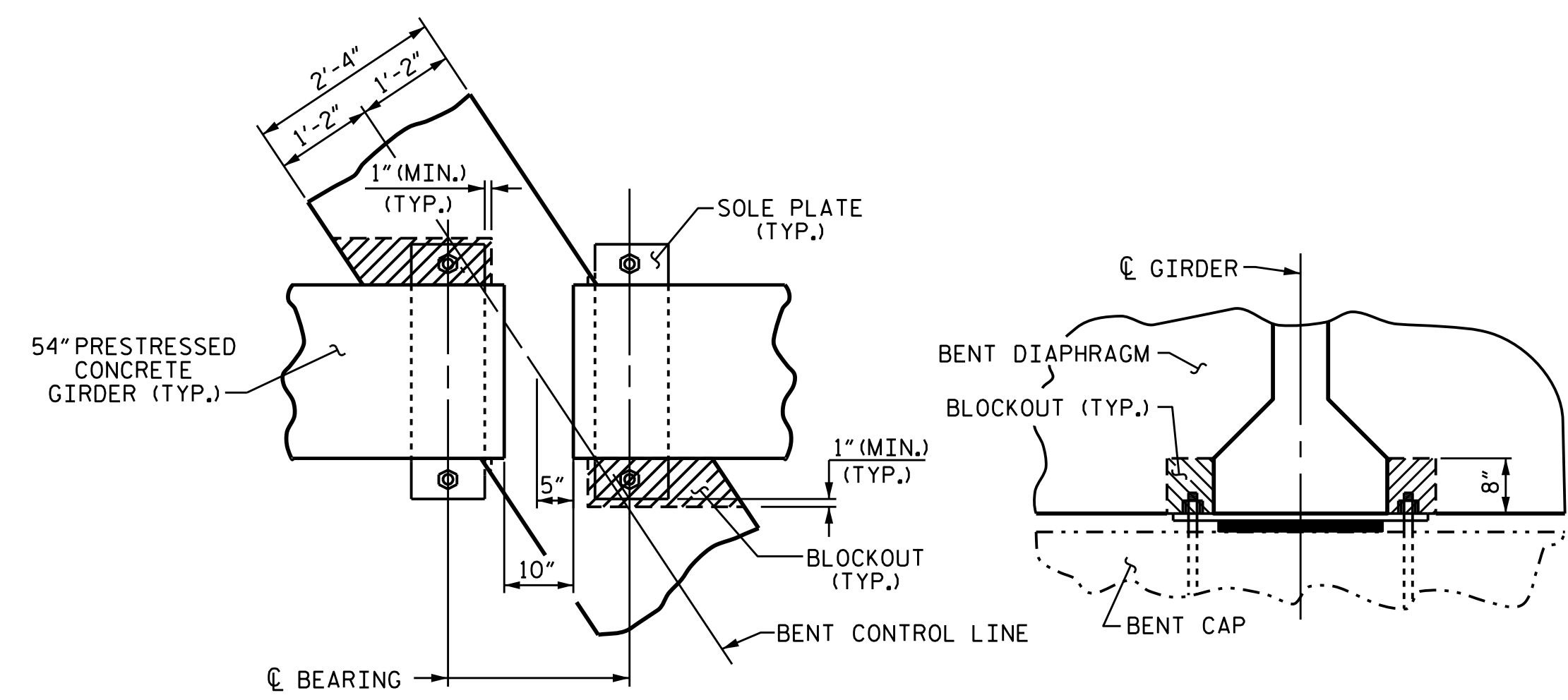

PLAN
#5 S7 BARS NOT SHOWN

SECTION

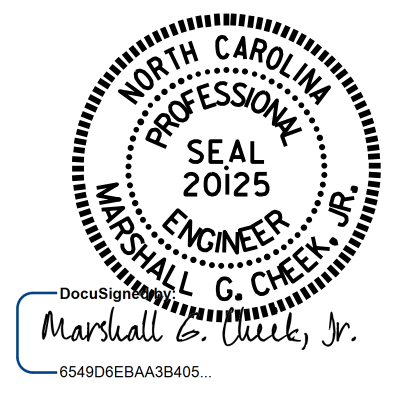

PROJECT NO. U-2579C
FORSYTH COUNTY
STATION: 473+70.00 -L-

SHEET 1 OF 2

STATE OF NORTH CAROLINA
DEPARTMENT OF TRANSPORTATION
RALEIGH

SUPERSTRUCTURE

TYPICAL SECTION

(RIGHT LANE)

REVISIONS						SHEET NO.	
NO.	BY:	DATE:	NO.	BY:	DATE:	S4-5	
1			3			TOTAL SHEETS	
2			4			33	

DRAWN BY: J. K. BOWLES DATE: 4/7/16
CHECKED BY: K. D. LAYNE DATE: 6/15/16
DESIGN ENGINEER OF RECORD: H. A. LOCKLEAR DATE: 6/2017

DOCUMENT NOT CONSIDERED
FINAL UNLESS ALL
SIGNATURES COMPLETED

NOTES

- PROVIDE 1/4" HIGH BEAM BOLSTERS UPPER AT 4'-0" CTS. ATOP THE METAL STAY-IN-PLACE FORMS TO SUPPORT THE BOTTOM MAT OF "A" BARS. WHEN USING REMOVABLE FORMS, PROVIDE CONTINUOUS HIGH CHAIRS FOR METAL DECK (C.H.C.M.) @ 4'-0" CTS. WITH A HEIGHT TO SUPPORT THE BOTTOM MAT OF "A" BARS A CLEAR DISTANCE OF 2 1/2" ABOVE THE TOP OF THE REMOVABLE FORM.
- LONGITUDINAL STEEL MAY BE SHIFTED SLIGHTLY, AS NECESSARY, TO AVOID INTERFERENCE WITH STIRRUPS IN PRESTRESSED CONCRETE GIRDERS.
- BARRIER RAIL IN A CONTINUOUS UNIT SHALL NOT BE CAST UNTIL ALL SLAB CONCRETE IN THE UNIT HAS BEEN CAST AND HAS REACHED A MINIMUM COMPRESSIVE STRENGTH OF 3,000 PSI.
- * FOR INTERMEDIATE STEEL DIAPHRAGM DETAILS, SEE "INTERMEDIATE STEEL DIAPHRAGMS FOR TYPE IV PRESTRESSED CONCRETE GIRDERS" SHEET.

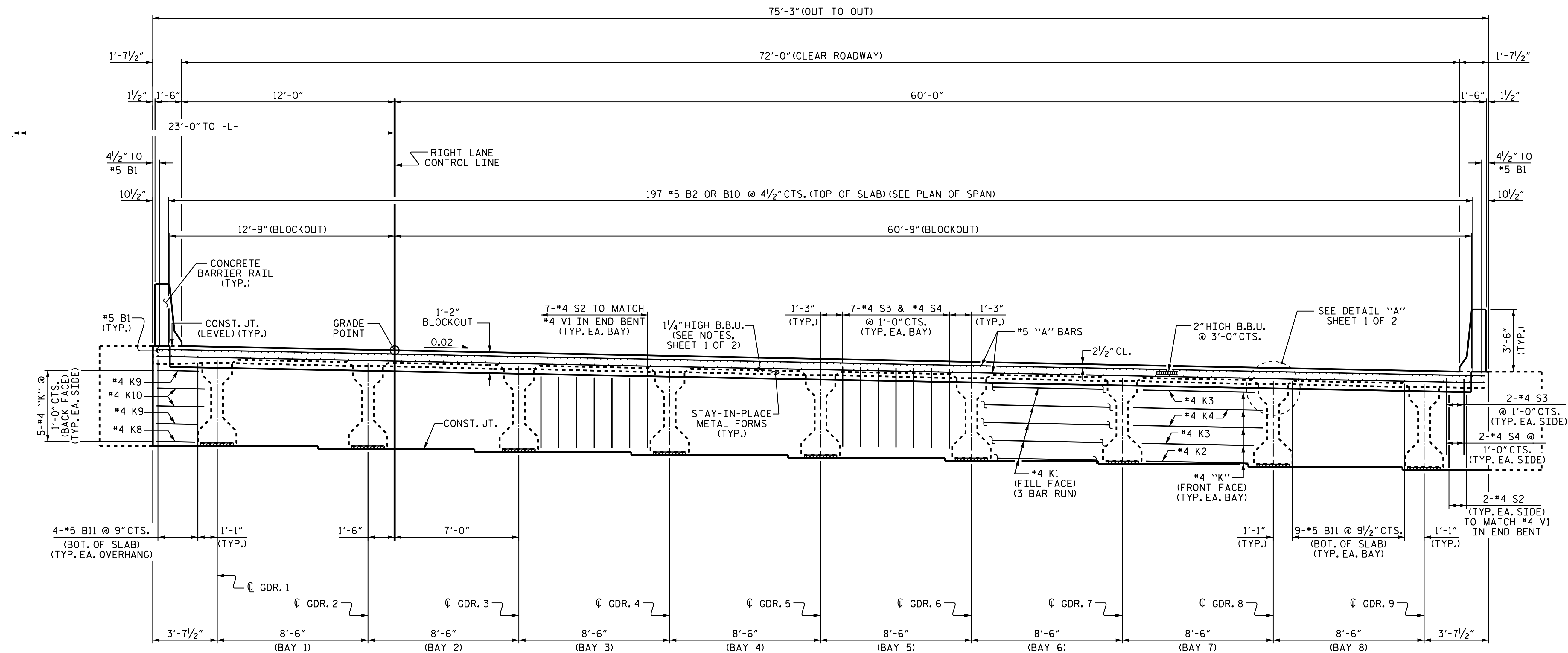

TYPICAL SECTION AT INTEGRAL END BENT

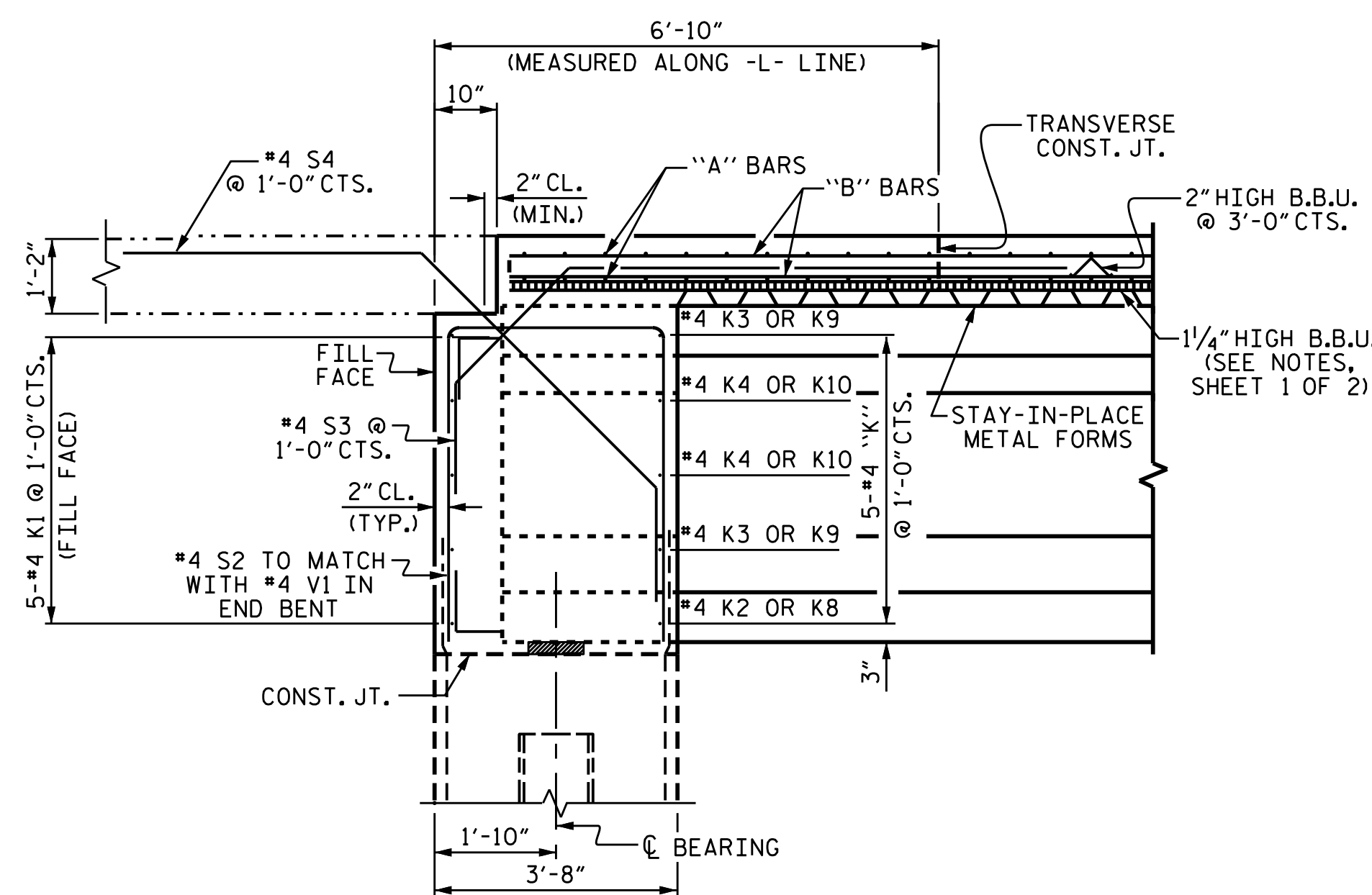

SECTION THROUGH INTEGRAL END BENT

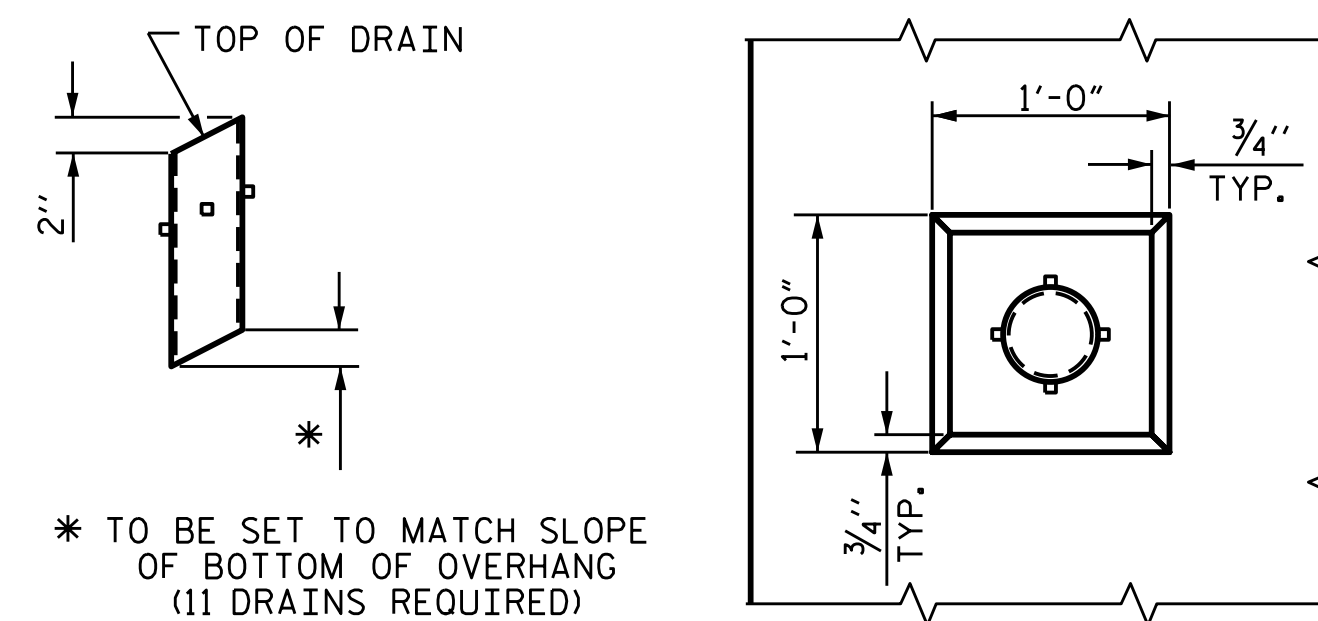

PIPE DETAIL

PLAN OF RECESS

TOP OF FLOOR DRAINS TO BE SET 3/8" BELOW SURFACE OF SLAB.

4 - 1/2" SQUARE LUGS TO BE GLUED TO THE P.V.C. PIPE AT EQUAL SPACES AROUND THE PIPE DRAIN APPROXIMATELY 4" FROM THE TOP OF THE PIPE.

THE 6" Ø PVC PIPE AND FITTINGS SHALL BE SCHEDULE 40 AND CONFORM TO ASTM D1785.

DRAIN DETAILS

PROJECT NO. U-2579C
 FORSYTH COUNTY
 STATION: 473+70.00 -L-

SHEET 2 OF 2

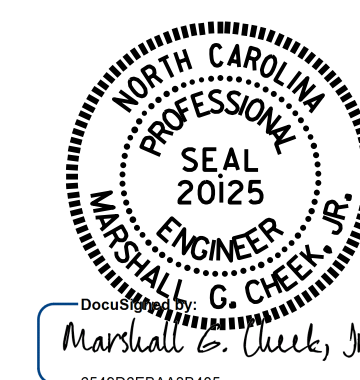

STATE OF NORTH CAROLINA
 DEPARTMENT OF TRANSPORTATION
 RALEIGH

SUPERSTRUCTURE

TYPICAL SECTION

(RIGHT LANE)

DRAWN BY: J. K. BOWLES DATE: 4/7/16
 CHECKED BY: K. D. LAYNE DATE: 6/15/16
 DESIGN ENGINEER OF RECORD: H. A. LOCKLEAR DATE: 6/2017

DOCUMENT NOT CONSIDERED
 FINAL UNLESS ALL
 SIGNATURES COMPLETED

REVISIONS						SHEET NO.	
NO.	BY:	DATE:	NO.	BY:	DATE:	S4-6	
1			3			TOTAL SHEETS	
2			4			33	

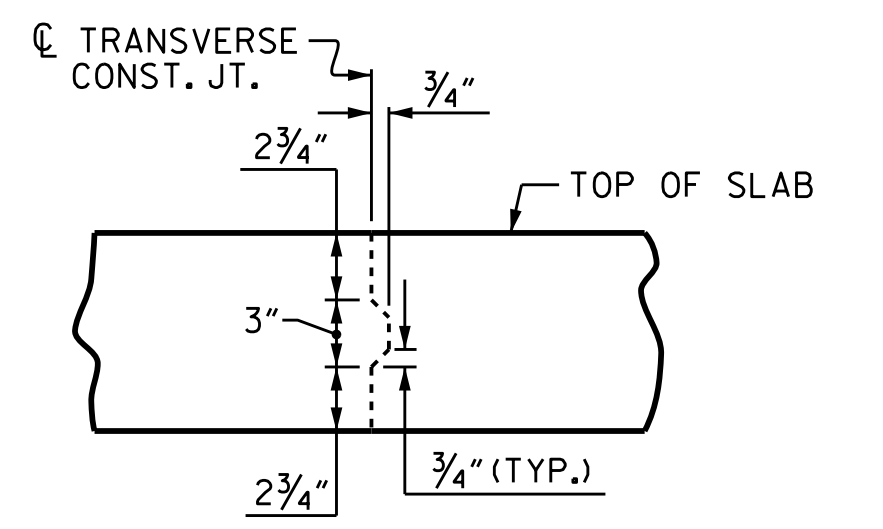
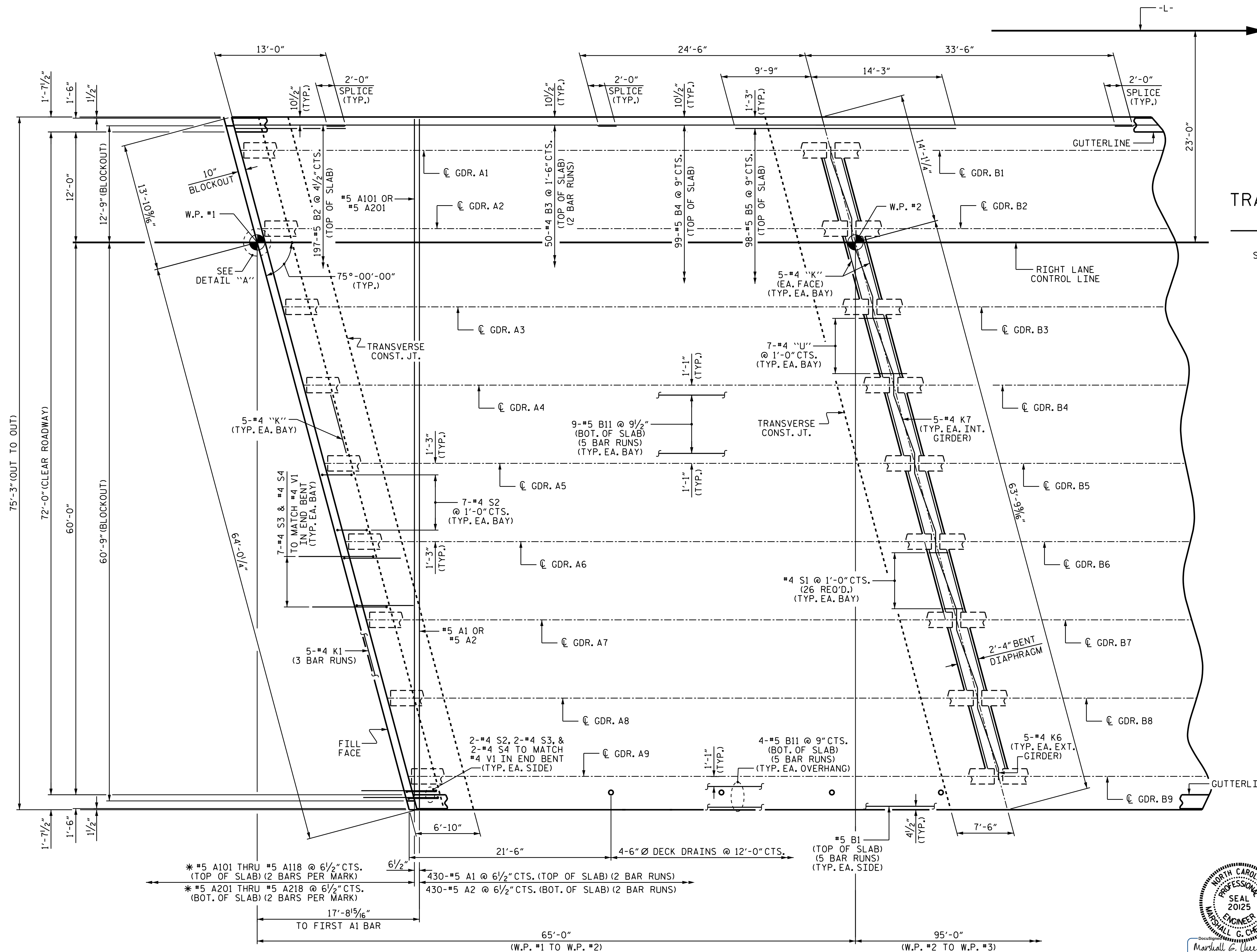

TRANSVERSE CONSTRUCTION JOINT DETAIL

NOTE: REINFORCING STEEL IN SLAB NOT SHOWN. LONGITUDINAL REINFORCING STEEL SHALL BE CONTINUOUS THROUGH JOINT.

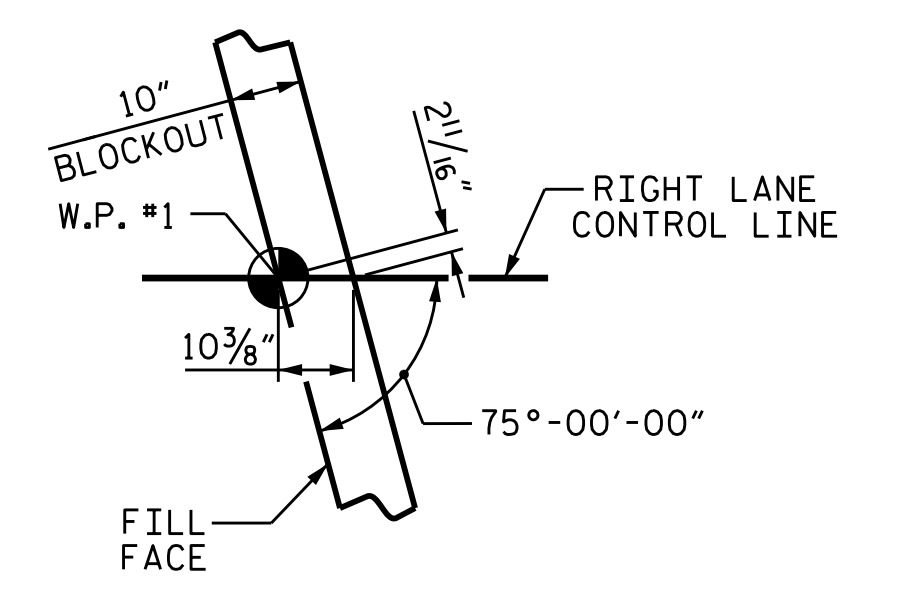

DETAIL "A"

PLAN OF SPAN A

INTERMEDIATE STEEL DIAPHRAGMS NOT SHOWN FOR CLARITY. FOR DETAILS, SEE "INTERMEDIATE STEEL DIAPHRAGMS FOR PRESTRESSED CONCRETE GIRDERS" SHEET.

* 2 BAR RUNS FOR A101 THROUGH A103 & A201 THROUGH A203.

PROJECT NO. U-2579C
 FORSYTH COUNTY
 STATION: 473+70.00 -L-

SHEET 1 OF 3



STATE OF NORTH CAROLINA
 DEPARTMENT OF TRANSPORTATION
 RALEIGH
 SUPERSTRUCTURE
 PLAN OF SPAN A
 (RIGHT LANE)

DRAWN BY: J. K. BOWLES DATE: 4/7/16
 CHECKED BY: K. D. LAYNE DATE: 6/15/16
 DESIGN ENGINEER OF RECORD: H. A. LOCKLEAR DATE: 6/2017

DOCUMENT NOT CONSIDERED FINAL UNLESS ALL SIGNATURES COMPLETED

REVISIONS						SHEET NO. S4-7
NO.	BY:	DATE:	NO.	BY:	DATE:	
1			3			TOTAL SHEETS 33
2			4			

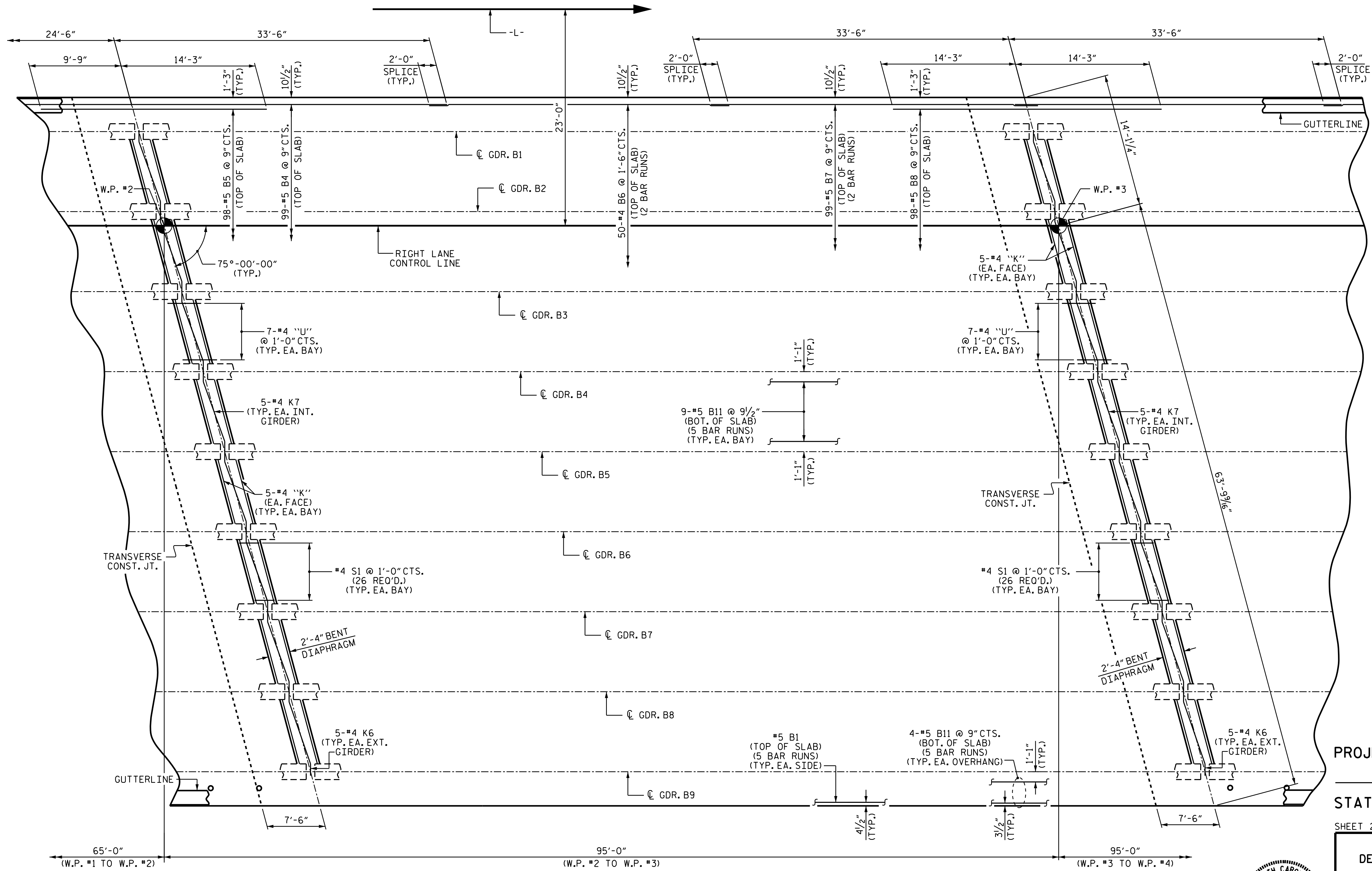

PLAN OF SPAN B

INTERMEDIATE STEEL DIAPHRAGMS NOT SHOWN FOR CLARITY. FOR DETAILS, SEE "INTERMEDIATE STEEL DIAPHRAGMS FOR PRESTRESSED CONCRETE GIRDERS" SHEET.

PROJECT NO. U-2579C
 FORSYTH COUNTY
 STATION: 473+70.00 -L-

SHEET 2 OF 3

STATE OF NORTH CAROLINA
 DEPARTMENT OF TRANSPORTATION
 RALEIGH

SUPERSTRUCTURE
 PLAN OF SPAN B
 (RIGHT LANE)

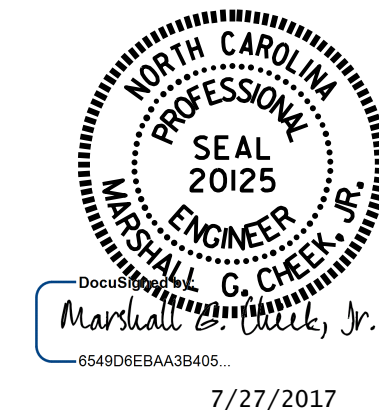

DRAWN BY: J. K. BOWLES DATE: 4/7/16
 CHECKED BY: K. D. LAYNE DATE: 6/15/16
 DESIGN ENGINEER OF RECORD: H. A. LOCKLEAR DATE: 6/2017

DOCUMENT NOT CONSIDERED FINAL UNLESS ALL SIGNATURES COMPLETED

REVISIONS						SHEET NO.	
NO.	BY:	DATE:	NO.	BY:	DATE:	S4-8	
1			3			TOTAL SHEETS	
2			4			33	

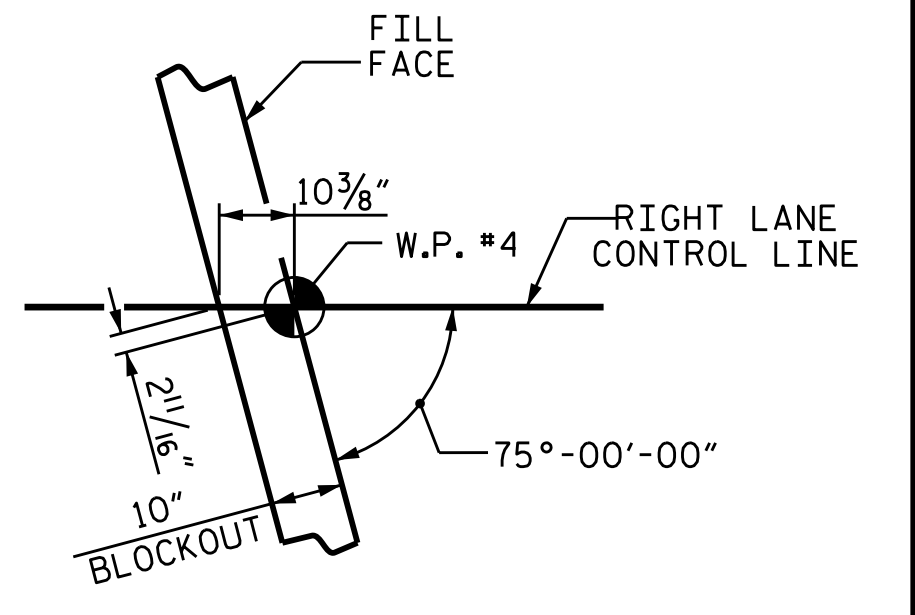
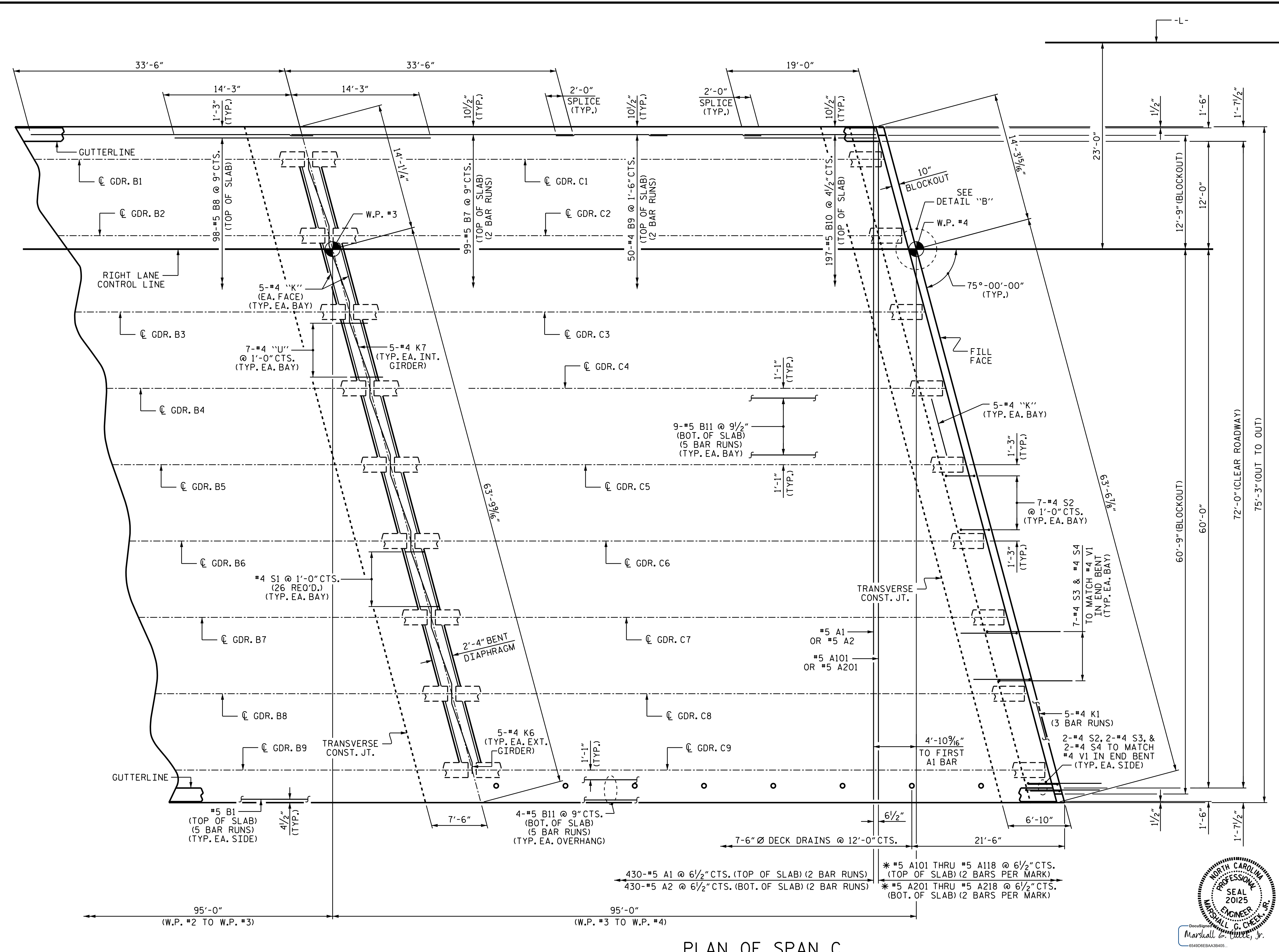

DETAIL "B"

PROJECT NO. U-2579C
 FORSYTH COUNTY
 STATION: 473+70.00 -L-

SHEET 3 OF 3

STATE OF NORTH CAROLINA
 DEPARTMENT OF TRANSPORTATION
 RALEIGH

SUPERSTRUCTURE
 PLAN OF SPAN C
 (RIGHT LANE)



DRAWN BY :	J. K. BOWLES	DATE :	4/7/16
CHECKED BY :	K. D. LAYNE	DATE :	6/15/16
DESIGN ENGINEER OF RECORD :	H. A. LOCKLEAR	DATE :	6/2017

PLAN OF SPAN C
 INTERMEDIATE STEEL DIAPHRAGMS NOT SHOWN FOR CLARITY. FOR DETAILS, SEE "INTERMEDIATE STEEL DIAPHRAGMS FOR PRESTRESSED CONCRETE GIRDERS" SHEET.
 * 2 BAR RUNS FOR A101 THROUGH A103 & A201 THROUGH A203.

DOCUMENT NOT CONSIDERED FINAL UNLESS ALL SIGNATURES COMPLETED

NO.	REVISIONS				SHEET NO.
	BY:	DATE:	NO.	DATE:	
1			3		S4-9
2			4		TOTAL SHEETS 33

INTEGRAL
E1

FIXED
E2,P2

FIXED
E2,P1

FIXED
E2,P3

FIXED
E2,P1

INTEGRAL
E1

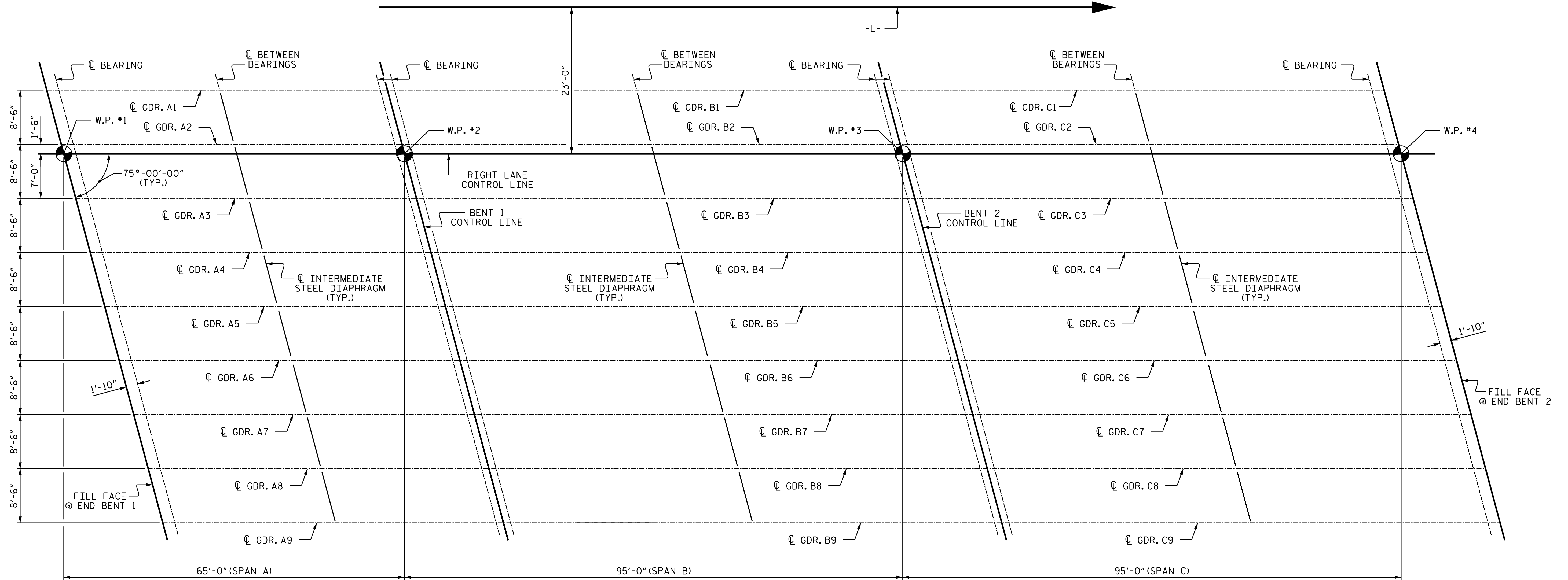

FRAMING PLAN

PROJECT NO. U-2579C
FORSYTH COUNTY
STATION: 473+70.00 -L-

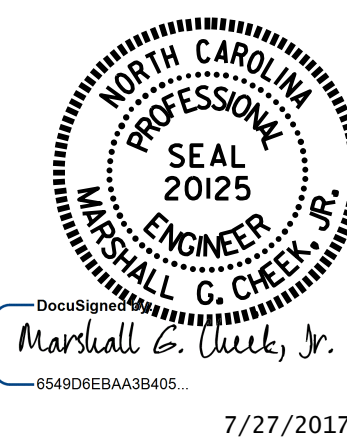

STATE OF NORTH CAROLINA
DEPARTMENT OF TRANSPORTATION
RALEIGH

SUPERSTRUCTURE
FRAMING PLAN
(RIGHT LANE)

DRAWN BY : J. K. BOWLES DATE : 4/7/16
 CHECKED BY : K. D. LAYNE DATE : 6/15/16
 DESIGN ENGINEER OF RECORD: H. A. LOCKLEAR DATE : 6/2017

DOCUMENT NOT CONSIDERED
FINAL UNLESS ALL
SIGNATURES COMPLETED

REVISIONS						SHEET NO.	
NO.	BY:	DATE:	NO.	BY:	DATE:	S4-10	
1			3			TOTAL SHEETS	
2			4			33	

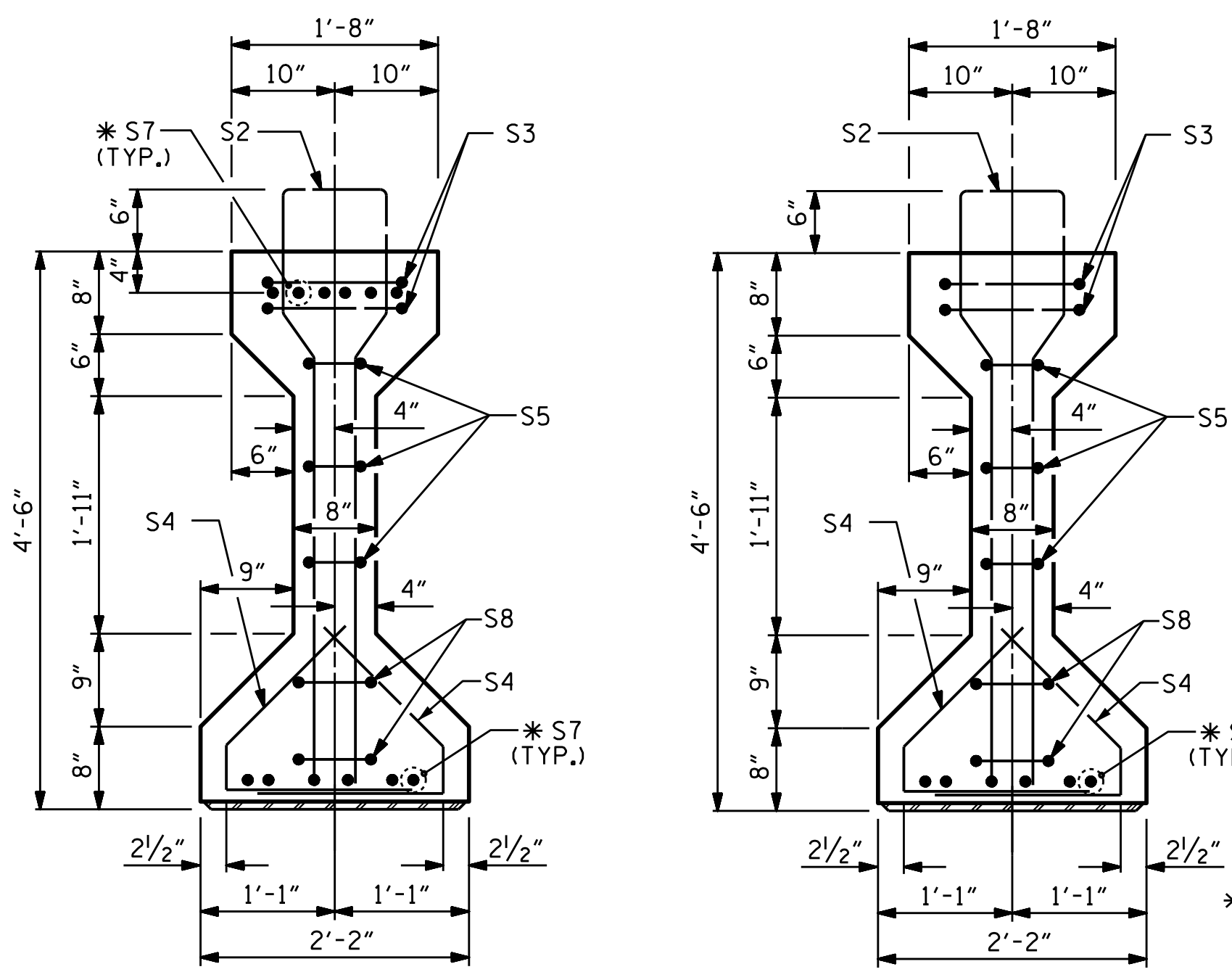

SECTION A-A

SECTION B-B

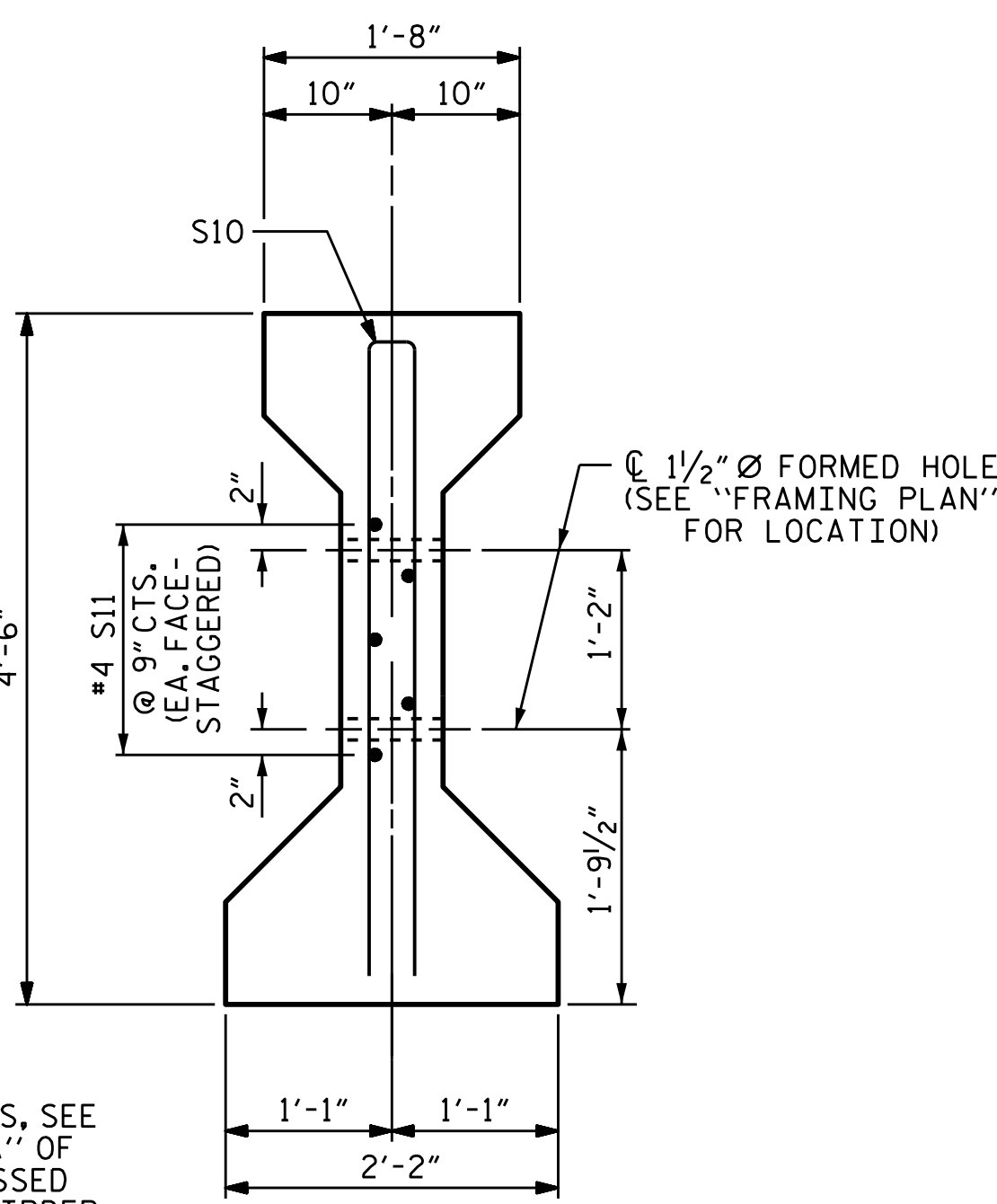

SECTION C-C
(S1 BARS NOT SHOWN)

* FOR S7 BARS, SEE
DETAIL "A" OF
"PRESTRESSED
CONCRETE GIRDER
CONTINUOUS FOR LIVE
LOAD DETAILS" SHEET

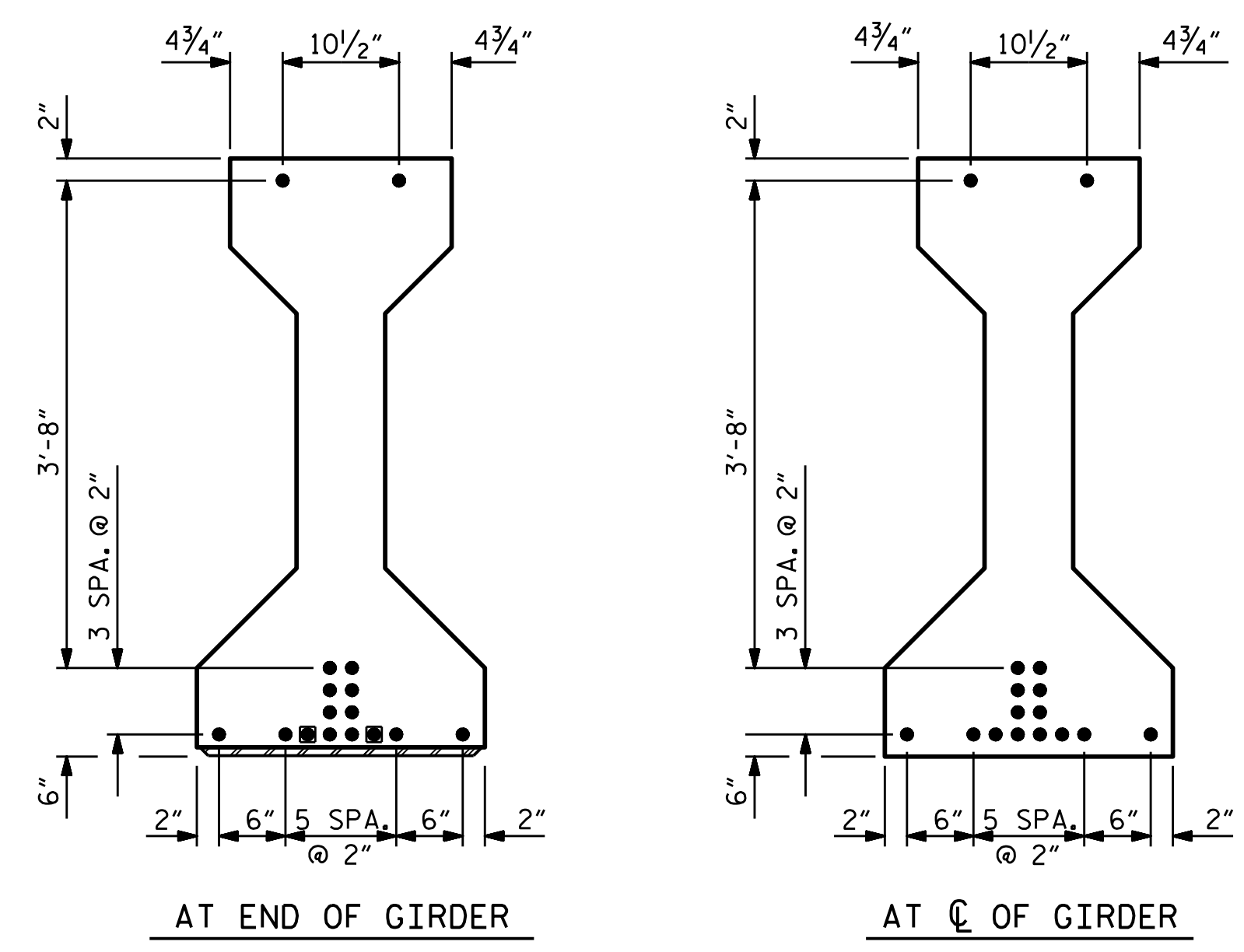

0.6" Ø LOW RELAXATION STRAND LAYOUT

● FULLY BONDED STRANDS
■ STRANDS DEBONDED FOR 12'-0" FROM END OF GIRDER

0.6" Ø L. R. GRADE 270 STRANDS

AREA (SQUARE INCHES)	ULTIMATE STRENGTH (LBS. PER STRAND)	APPLIED PRESTRESS (LBS. PER STRAND)
0.217	58,600	43,950

REINFORCING STEEL FOR ONE GIRDER

BAR	NUMBER	SIZE	TYPE	LENGTH	WEIGHT
S1	80	#4	1	10'-8"	570
S2	12	#6	1	10'-8"	192
S3	4	#4	2	9'-1"	24
S4	72	#4	3	3'-5"	164
S5	6	#4	2	8'-5"	34
* S7	18	#5	STR	3'-7"	69
S8	4	#4	2	8'-7"	23
S9	2	#3	STR	1'-10"	1
S10	2	#5	2	8'-8"	18
S11	5	#4	STR	7'-0"	23
S13	1	#3	STR	1'-4"	1

* NOTE: S7 BARS SHALL BE BENT BEFORE SHIPMENT. HEAT BENDING SHALL NOT BE ALLOWED.

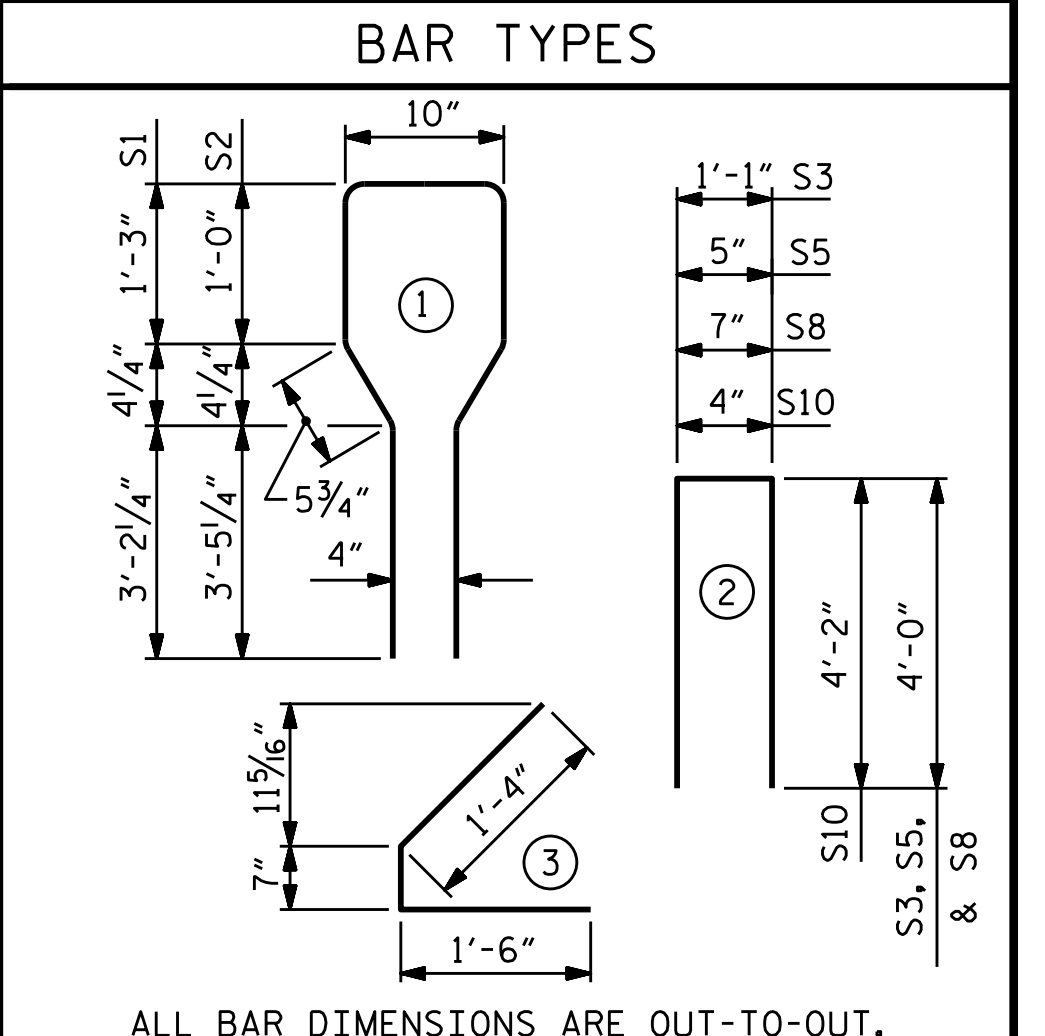

ALL BAR DIMENSIONS ARE OUT-TO-OUT.

QUANTITIES FOR ONE GIRDER

REINFORCING STEEL	5,000 PSI CONCRETE	0.6" Ø L. R. STRANDS
LBS.	C.Y.	No.
1,119	12.9	16

GIRDERS REQUIRED

NUMBER	LENGTH	TOTAL LENGTH
9	63'-4 3/4"	570'-6 3/4"

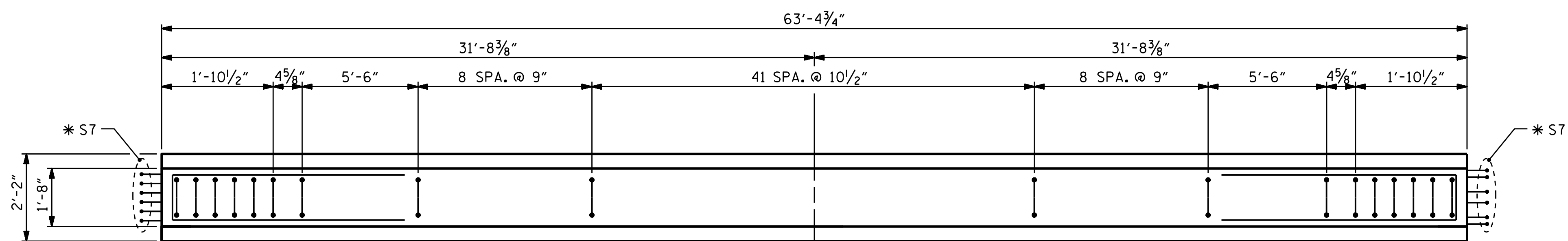

PLAN OF GIRDER

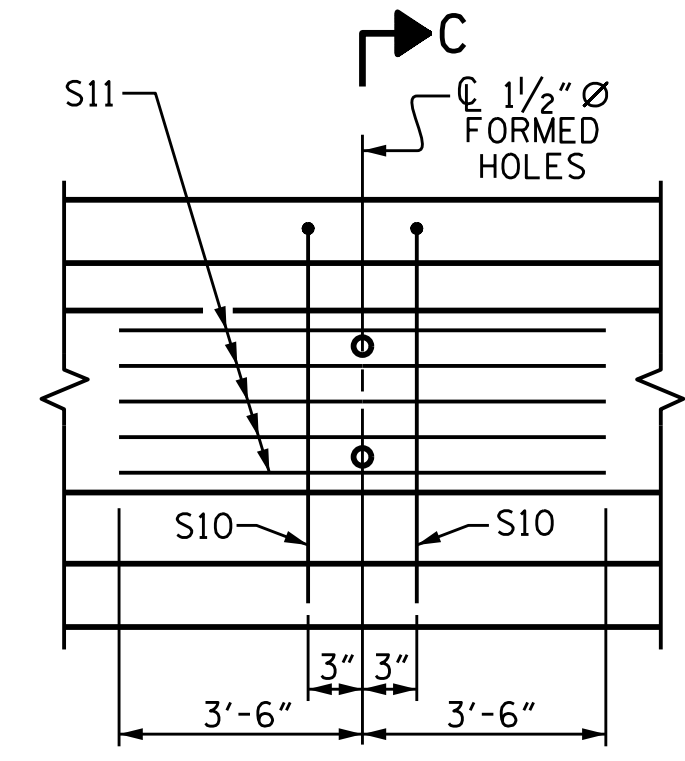

PARTIAL ELEVATION

SHOWING INTERMEDIATE DIAPHRAGM REINFORCING STEEL FOR SPAN A GIRDERS.

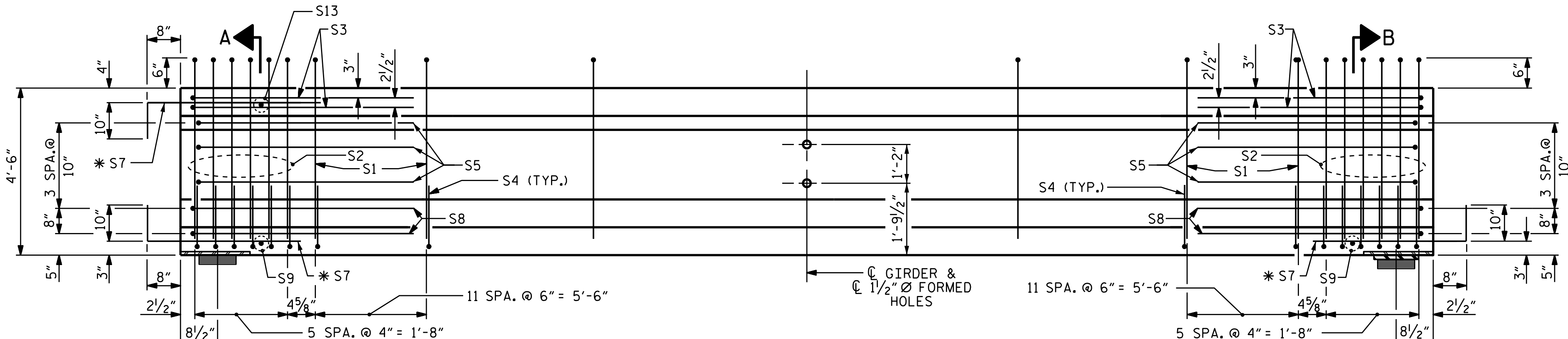

ELEVATION OF GIRDER

(SEE PARTIAL ELEVATION FOR ADDITIONAL "S" BARS)

INTEGRAL END BENT

FIX

ASSEMBLED BY : H. A. LOCKLEAR	DATE : 12-15
CHECKED BY : N. D'AUTO	DATE : 6/15/16
DRAWN BY : ELR 8/91	REV. 5/1/06R TLA/GM
CHECKED BY : GRP 8/91	REV. 10/1/11 MAA/GM
	REV. 1/15 MAA/TMG

DOCUMENT NOT CONSIDERED FINAL UNLESS ALL SIGNATURES COMPLETED



8/1/2017

PROJECT NO. U-2579C
FORSYTH COUNTY
STATION: 473+70.00 -L-

SHEET 1 OF 4

STATE OF NORTH CAROLINA
DEPARTMENT OF TRANSPORTATION
RALEIGH
STANDARD
AASHTO TYPE IV
PRESTRESSED CONCRETE GIRDER
CONTINUOUS FOR LIVE LOAD
SPAN A
(RIGHT LANE)

REVISIONS						SHEET NO.
NO.	BY:	DATE:	NO.	BY:	DATE:	S4-11
1			3			TOTAL SHEETS 33
2			4			

STR. #4 STD. NO. PCG6

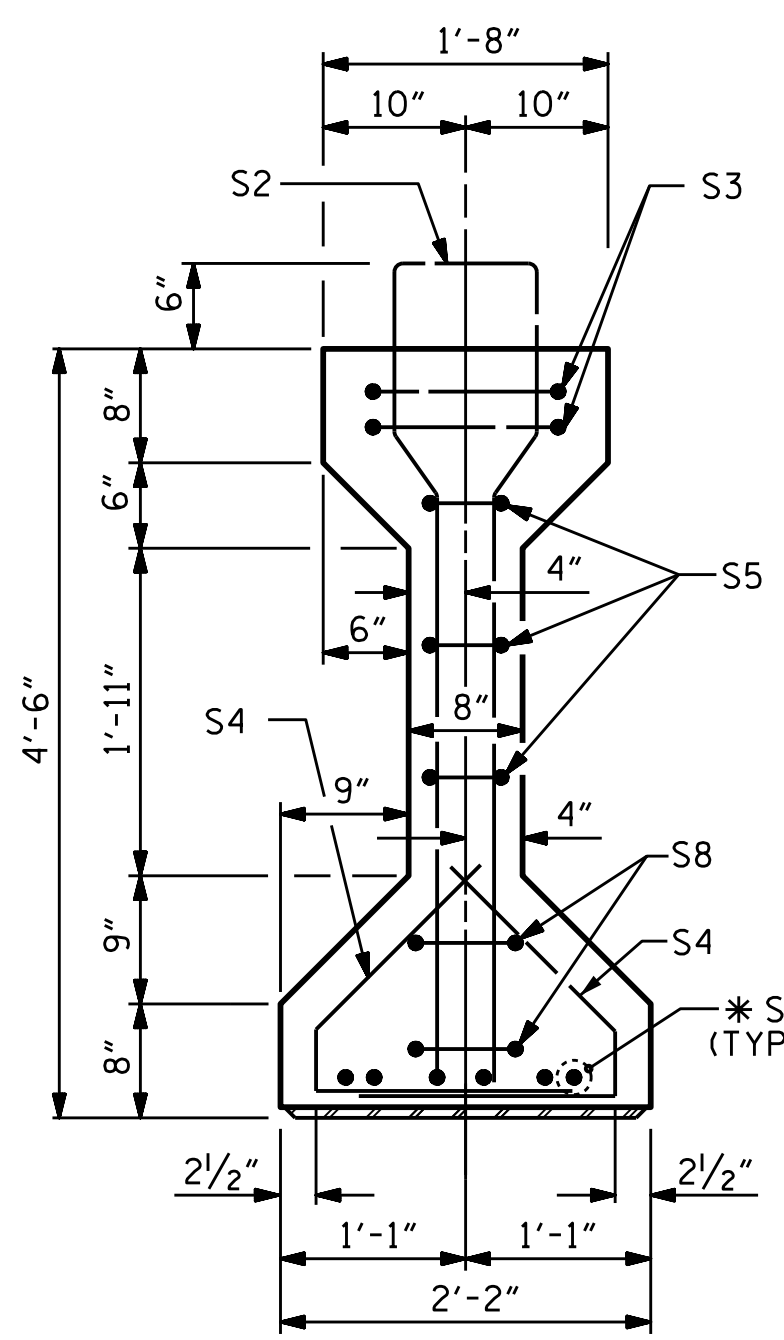

SECTION B-B

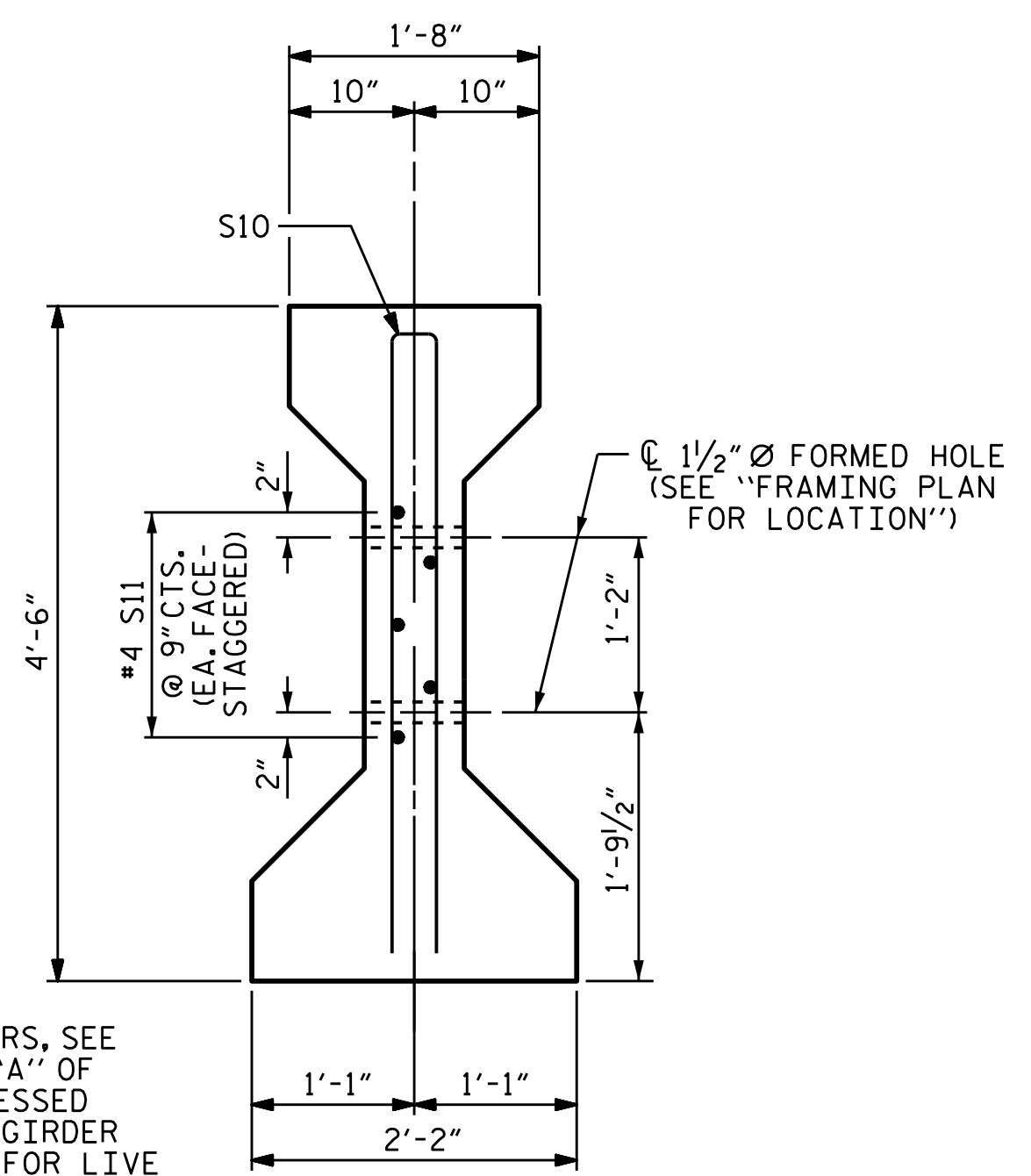

SECTION C-C
(S1 BARS NOT SHOWN)

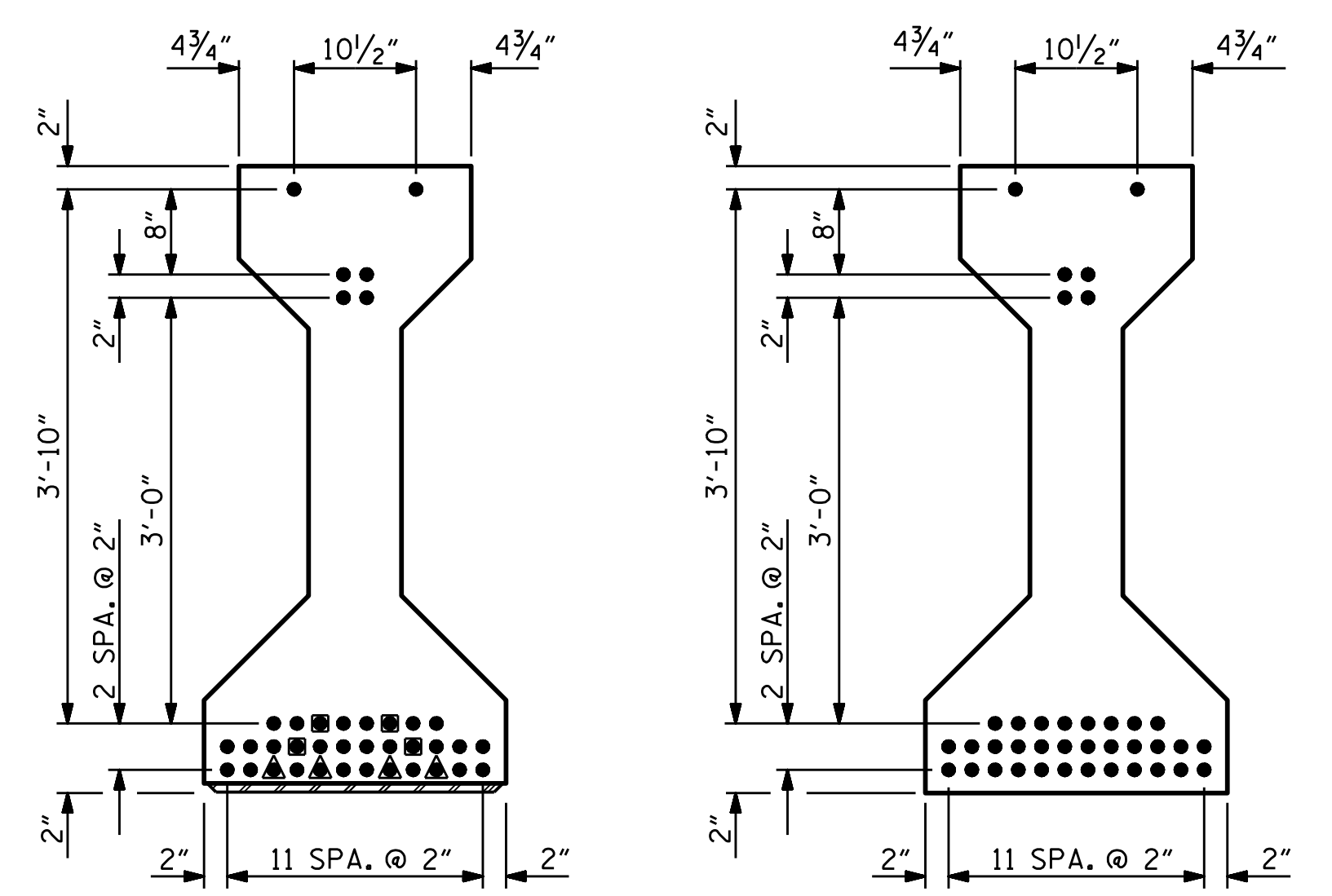

0.6" Ø LOW RELAXATION STRAND LAYOUT

- FULLY BONDED STRANDS
- STRANDS DEBONDED FOR 12'-0" FROM END OF GIRDER
- ▲ STRANDS DEBONDED FOR 10'-0" FROM END OF GIRDER

0.6" Ø L. R. GRADE 270 STRANDS

AREA (SQUARE INCHES)	ULTIMATE STRENGTH (LBS. PER STRAND)	APPLIED PRESTRESS (LBS. PER STRAND)
0.217	58,600	43,950

REINFORCING STEEL FOR ONE GIRDER

BAR	NUMBER	SIZE	TYPE	LENGTH	WEIGHT
S1	130	#4	1	10'-8"	926
S2	12	#6	1	10'-8"	192
S3	4	#4	2	9'-1"	24
S4	172	#4	3	3'-5"	393
S5	6	#4	2	8'-5"	34
* S7	12	#5	STR	3'-8"	46
S8	4	#4	2	8'-7"	23
S9	2	#3	STR	1'-10"	1
S10	2	#5	2	8'-8"	18
S11	5	#4	STR	7'-0"	23

* NOTE: S7 BARS SHALL BE BENT BEFORE SHIPMENT. HEAT BENDING SHALL NOT BE ALLOWED.

BAR TYPES

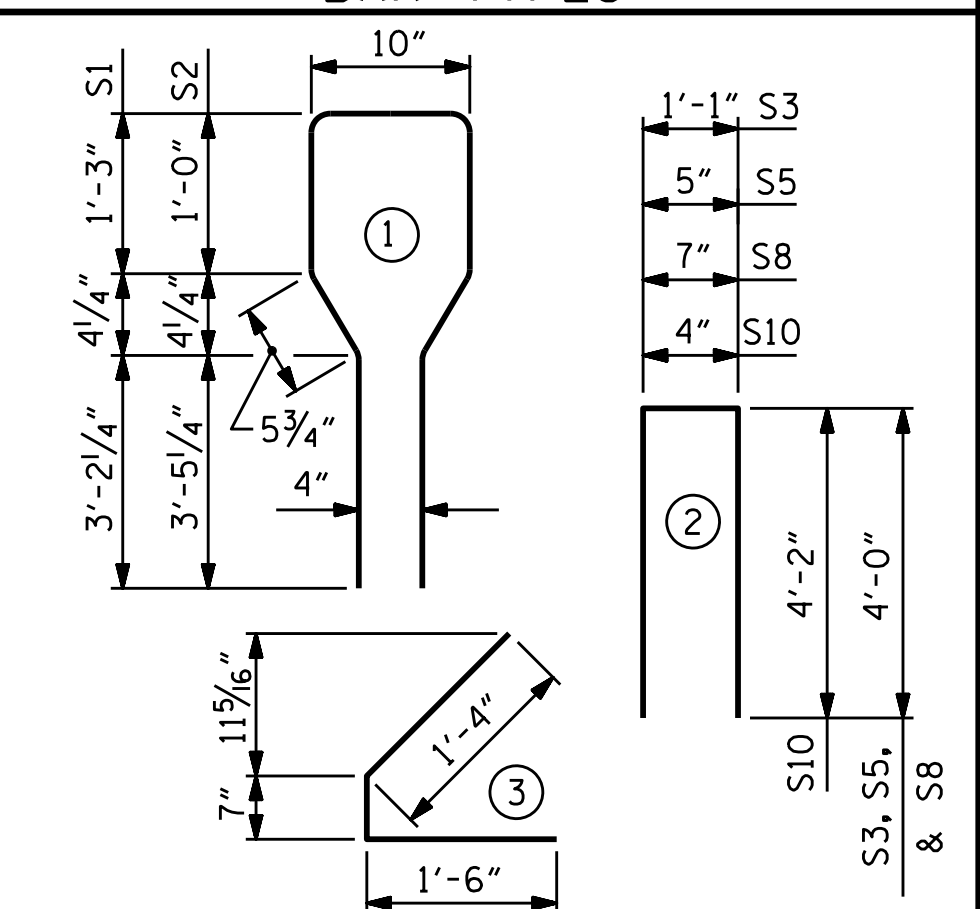

ALL BAR DIMENSIONS ARE OUT-TO-OUT.

QUANTITIES FOR ONE GIRDER

REINFORCING STEEL	7,500 PSI CONCRETE	0.6" Ø L. R. STRANDS
LBS.	C.Y.	No.
1,680	19.1	38

GIRDERS REQUIRED

NUMBER	LENGTH	TOTAL LENGTH
9	94'-2"	847'-6"

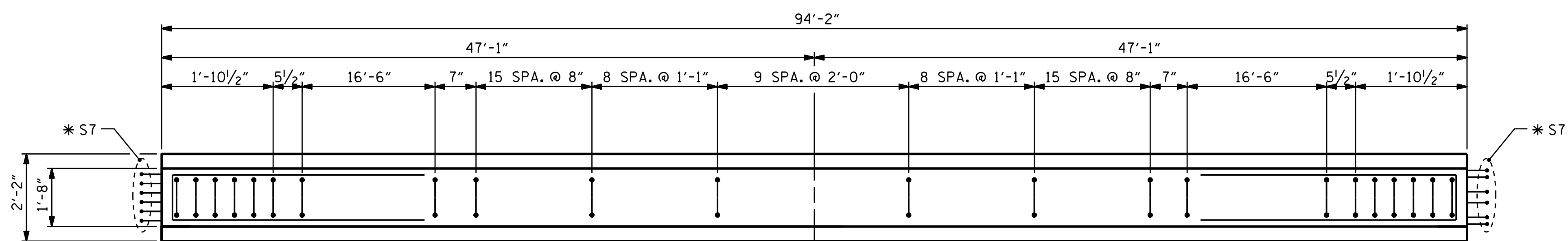

PLAN OF GIRDER

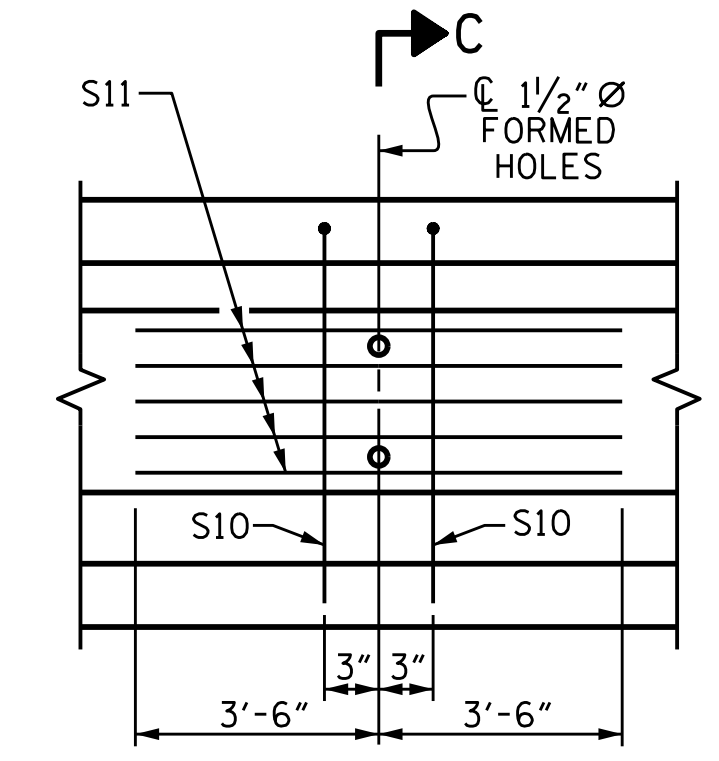

PARTIAL ELEVATION

SHOWING INTERMEDIATE DIAPHRAGM REINFORCING STEEL FOR SPAN B GIRDERS.

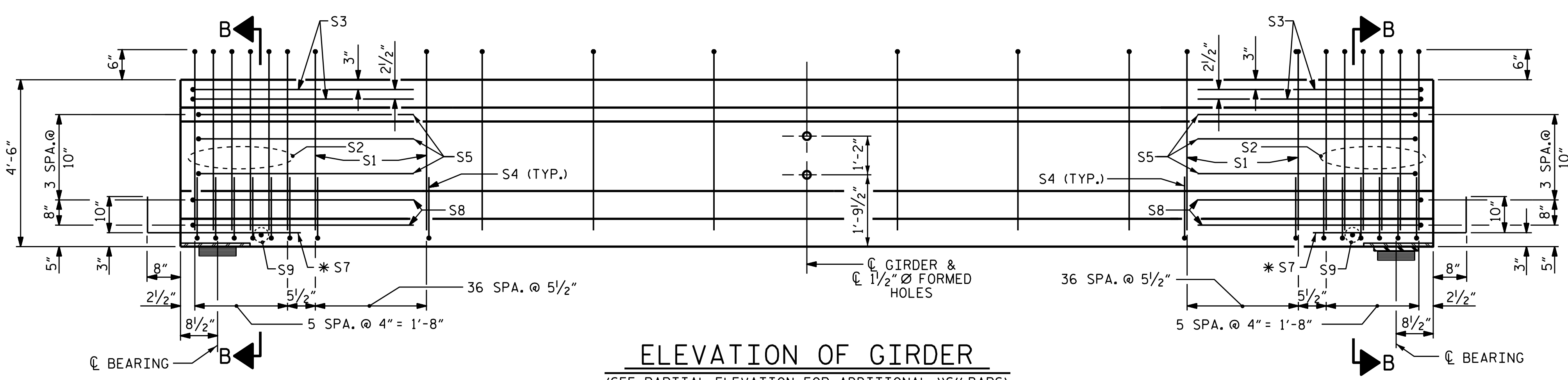

ELEVATION OF GIRDER

(SEE PARTIAL ELEVATION FOR ADDITIONAL "S" BARS)



7/27/2017

ASSEMBLED BY : H. A. LOCKLEAR	DATE : 12-15
CHECKED BY : N. D'AIUTO	DATE : 6/15/16
DRAWN BY : ELR 8/91	REV. 5/1/06R TLA/GM
CHECKED BY : GRP 8/91	REV. 10/1/11 MAA/GM
	REV. 1/15 MAA/TMG

DOCUMENT NOT CONSIDERED FINAL UNLESS ALL SIGNATURES COMPLETED

REVISIONS				SHEET NO.	
NO.	BY:	DATE:	NO.	BY:	DATE:
1			3		
2			4		

STR. #4 STD. NO. PCG6

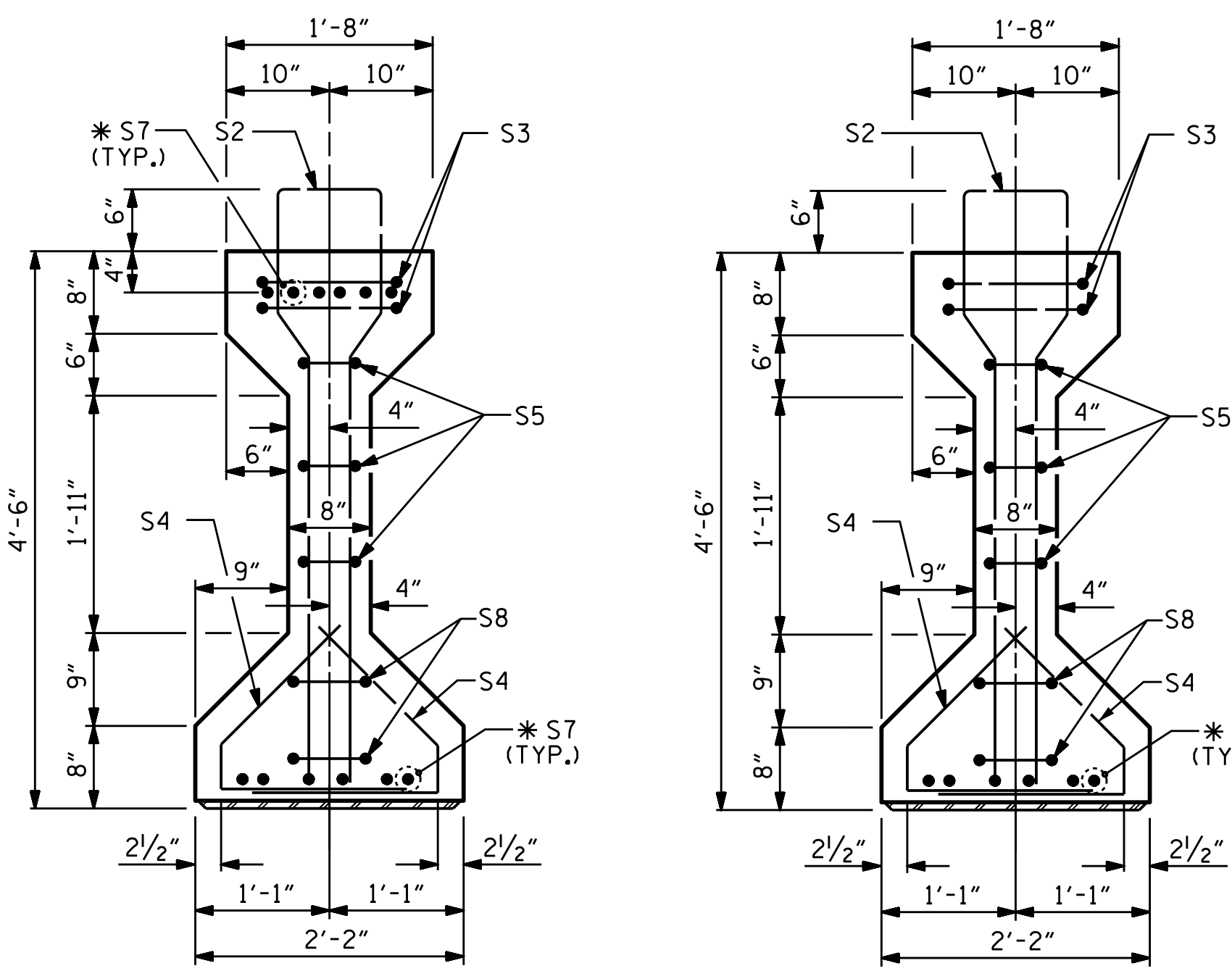

SECTION A-A

SECTION B-B

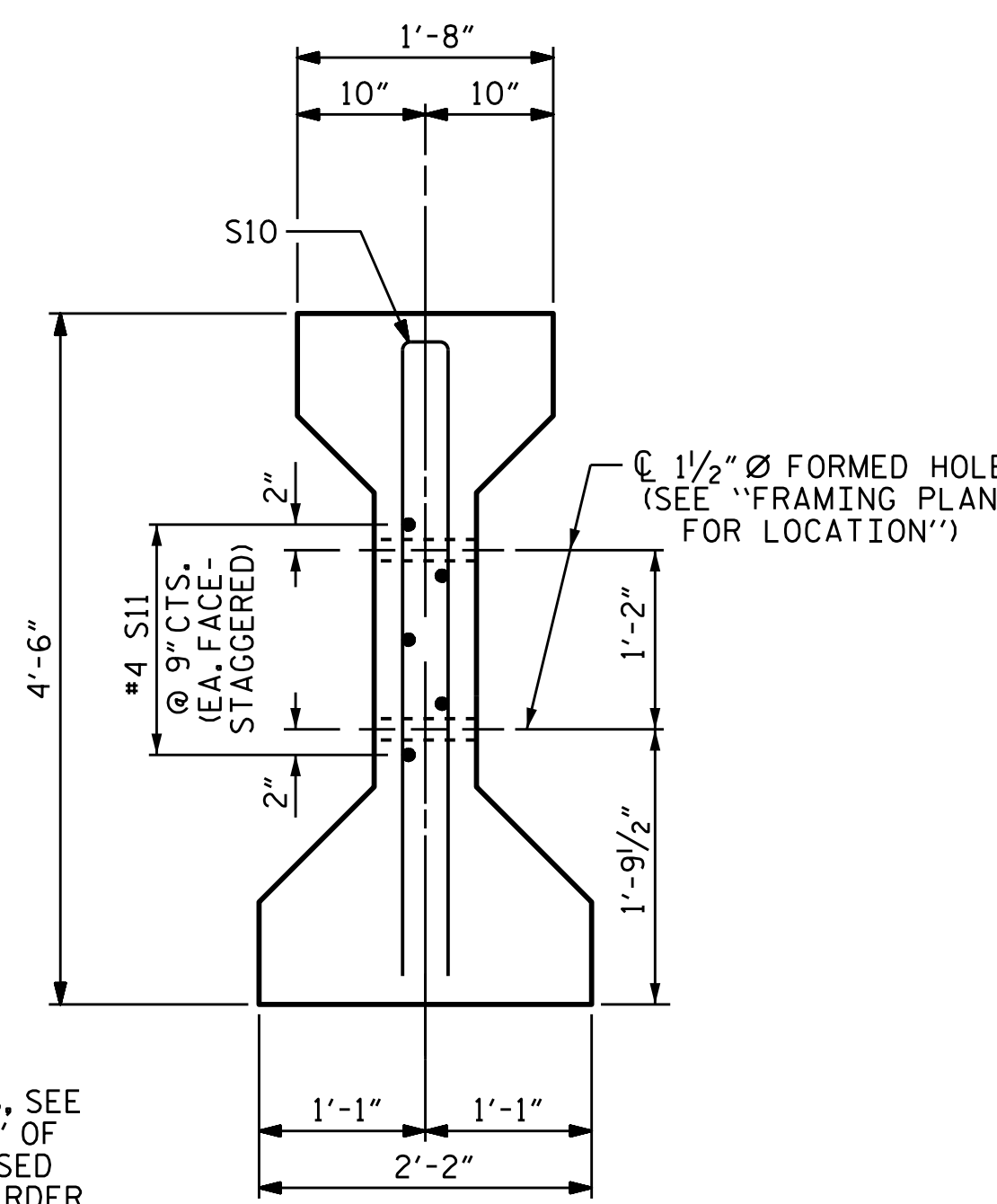

SECTION C-C
(S1 BARS NOT SHOWN)

* FOR S7 BARS, SEE
DETAIL "A" OF
"PRESTRESSED
CONCRETE GIRDER
CONTINUOUS FOR LIVE
LOAD DETAILS" SHEET

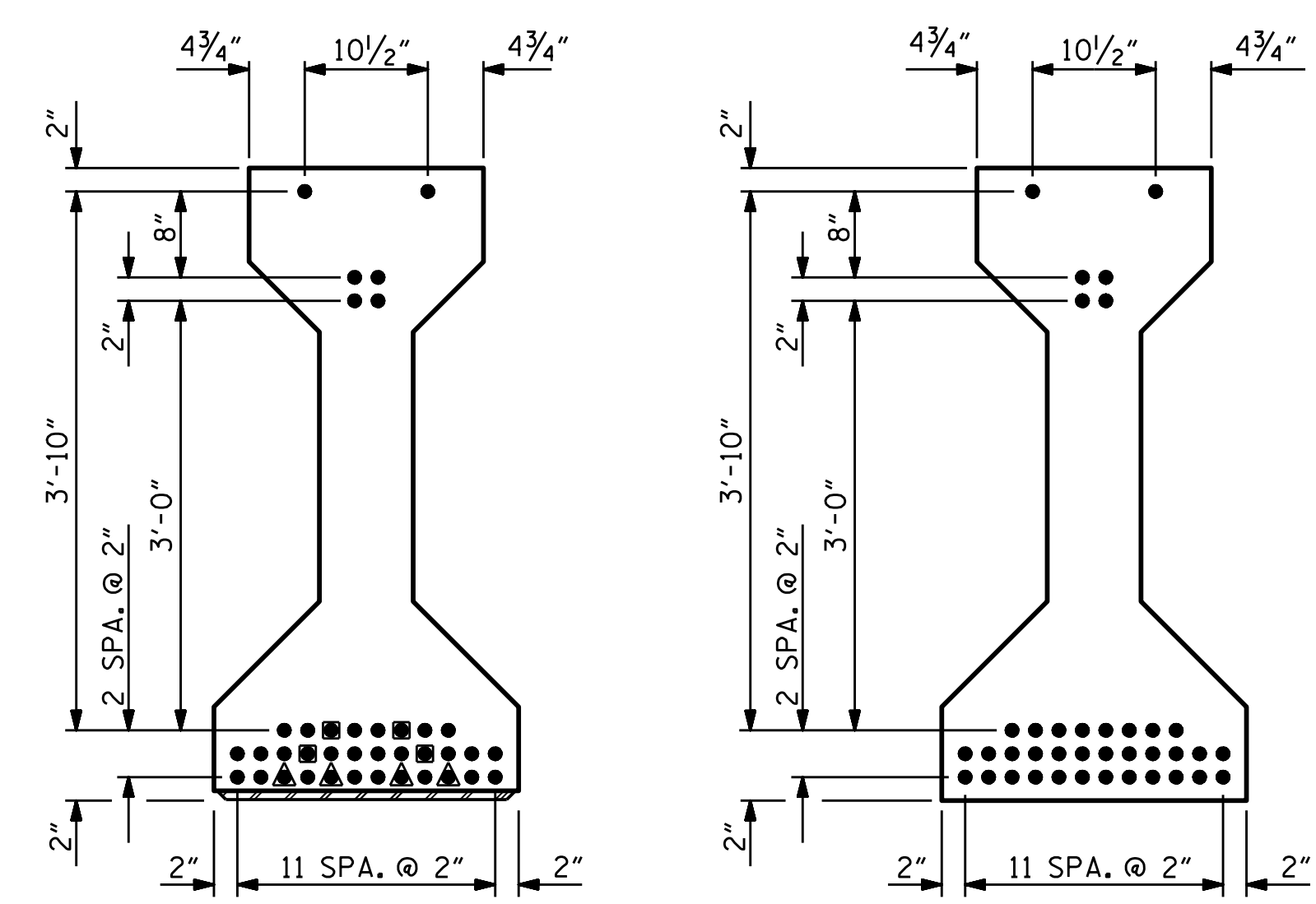

0.6" Ø LOW RELAXATION STRAND LAYOUT

- FULLY BONDED STRANDS
- STRANDS DEBONDED FOR 12'-0" FROM END OF GIRDER
- ▲ STRANDS DEBONDED FOR 10'-0" FROM END OF GIRDER

0.6" Ø L. R. GRADE 270 STRANDS

AREA (SQUARE INCHES)	ULTIMATE STRENGTH (LBS. PER STRAND)	APPLIED PRESTRESS (LBS. PER STRAND)
0.217	58,600	43,950

REINFORCING STEEL FOR ONE GIRDER

BAR	NUMBER	SIZE	TYPE	LENGTH	WEIGHT
S1	130	#4	1	10'-8"	926
S2	12	#6	1	10'-8"	192
S3	4	#4	2	9'-1"	24
S4	180	#4	3	3'-5"	411
S5	6	#4	2	8'-5"	34
*S7	18	#5	STR	3'-8"	69
S8	4	#4	2	8'-7"	23
S9	2	#3	STR	1'-10"	1
S10	2	#5	2	8'-8"	18
S11	5	#4	STR	7'-0"	23
S13	1	#3	STR	1'-4"	1

* NOTE: S7 BARS SHALL BE BENT BEFORE SHIPMENT. HEAT BENDING SHALL NOT BE ALLOWED.

BAR TYPES

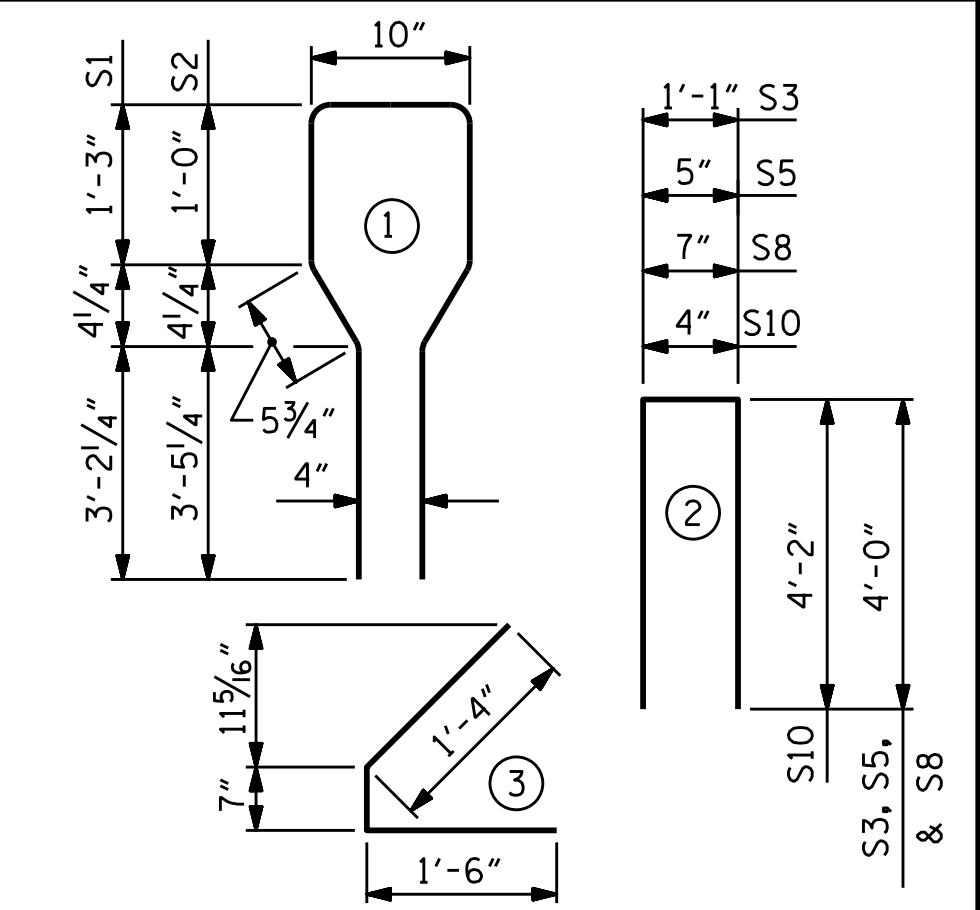

ALL BAR DIMENSIONS ARE OUT-TO-OUT.

QUANTITIES FOR ONE GIRDER

REINFORCING STEEL	7,500 PSI CONCRETE	0.6" Ø L. R. STRANDS
LBS.	C.Y.	No.
1722	19.0	38
GIRDERS REQUIRED		
NUMBER	LENGTH	TOTAL LENGTH
9	93'-4 3/4"	840'-6 3/4"

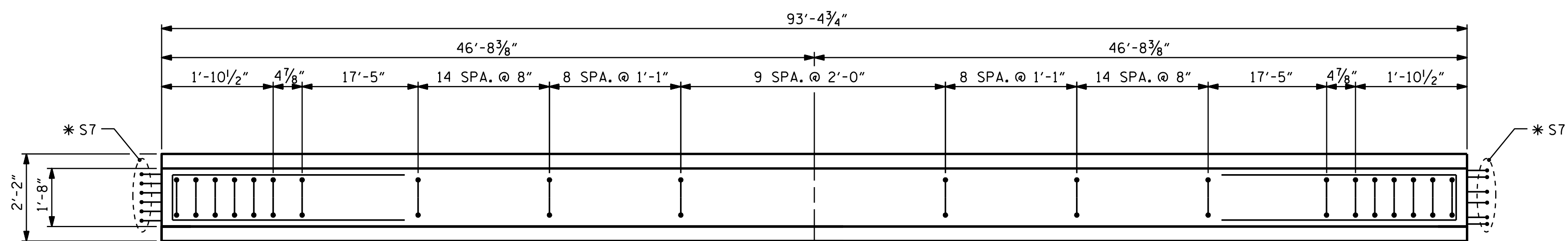

PLAN OF GIRDER

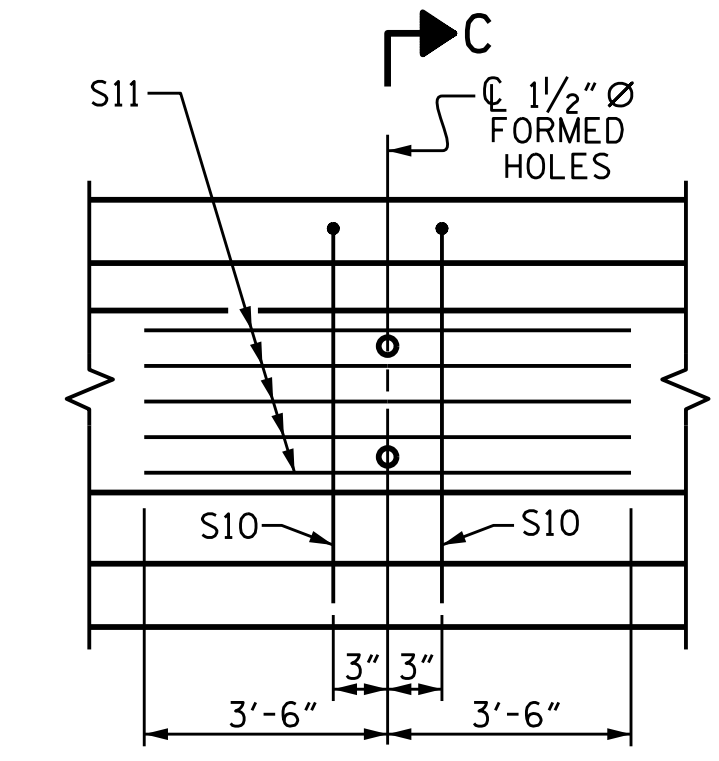

PARTIAL ELEVATION

SHOWING INTERMEDIATE DIAPHRAGM REINFORCING STEEL FOR SPAN C GIRDERS.

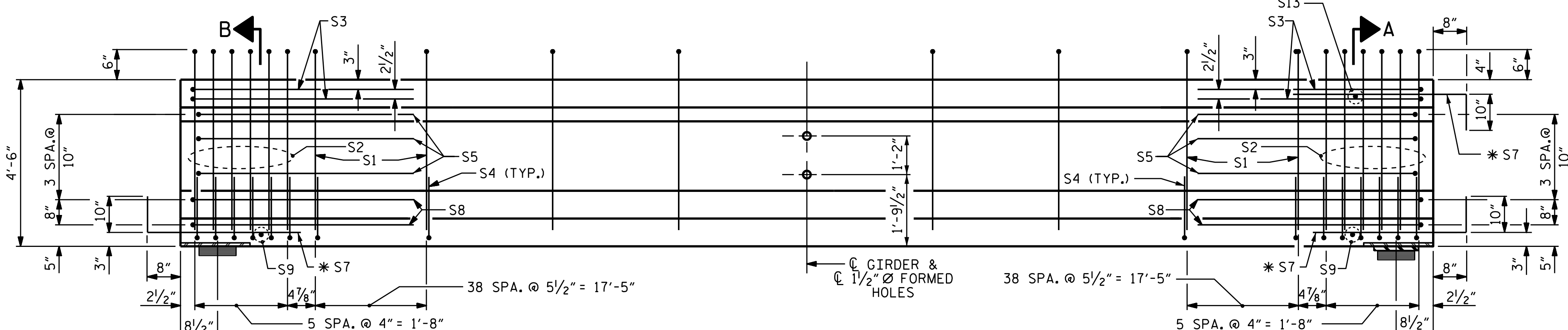

ELEVATION OF GIRDER
(SEE PARTIAL ELEVATION FOR ADDITIONAL "S" BARS)

INTEGRAL END BENT



ASSEMBLED BY : H. A. LOCKLEAR	DATE : 12-15
CHECKED BY : N. D'AIUTO	DATE : 6/15/16
DRAWN BY : ELR 8/91	REV. 5/1/06R TLA/GM
CHECKED BY : GRP 8/91	REV. 10/1/11 MAA/GM
	REV. 1/15 MAA/TMG

26-JUL-2017 15:08
R:\Structures\FINAL PLANS\404_025_U2579C.SMU.G3.013.330703.dgn
mcheek

DOCUMENT NOT CONSIDERED FINAL UNLESS ALL SIGNATURES COMPLETED

REVISIONS						SHEET NO.
NO.	BY:	DATE:	NO.	BY:	DATE:	S4-13
1			3			TOTAL SHEETS 33
2			4			

STR. #4 STD. NO. PCG6

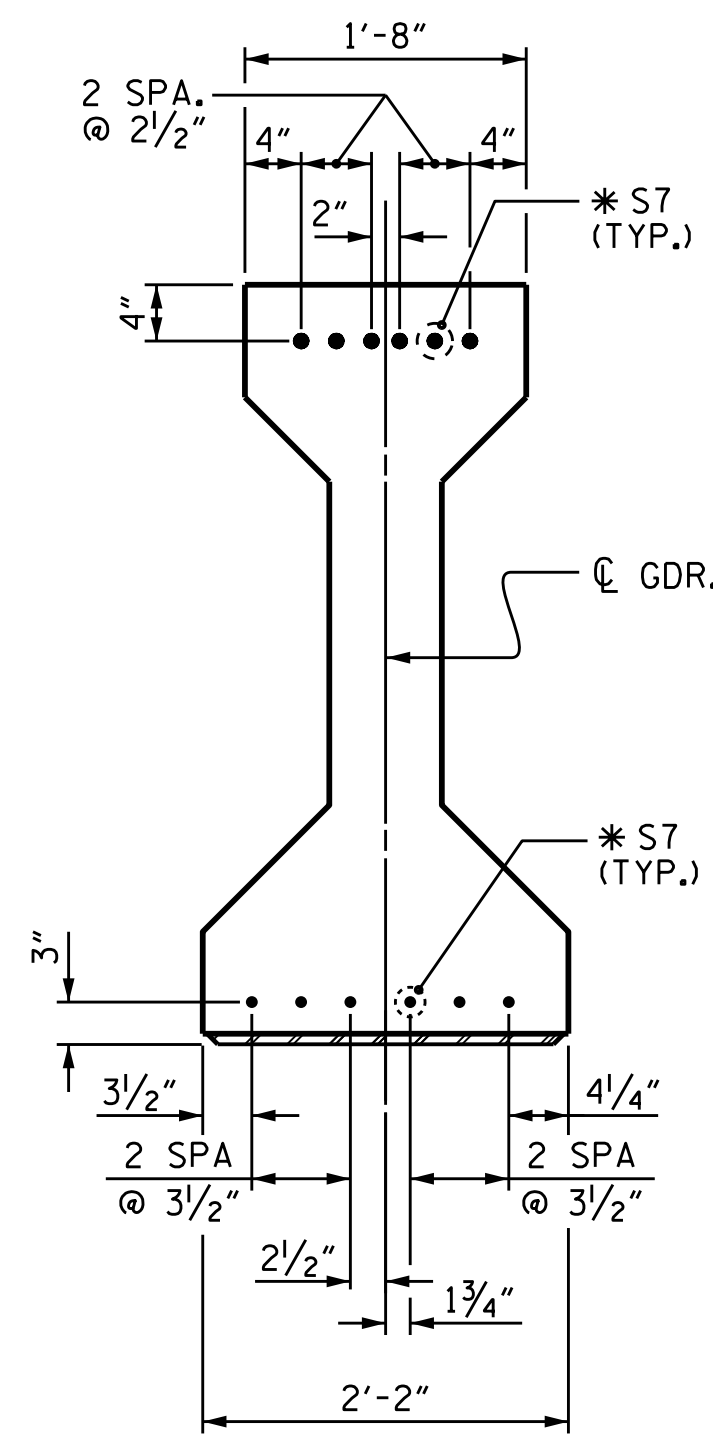

DETAIL "A"
(FOR AASHTO TYPE IV GIRDERS)

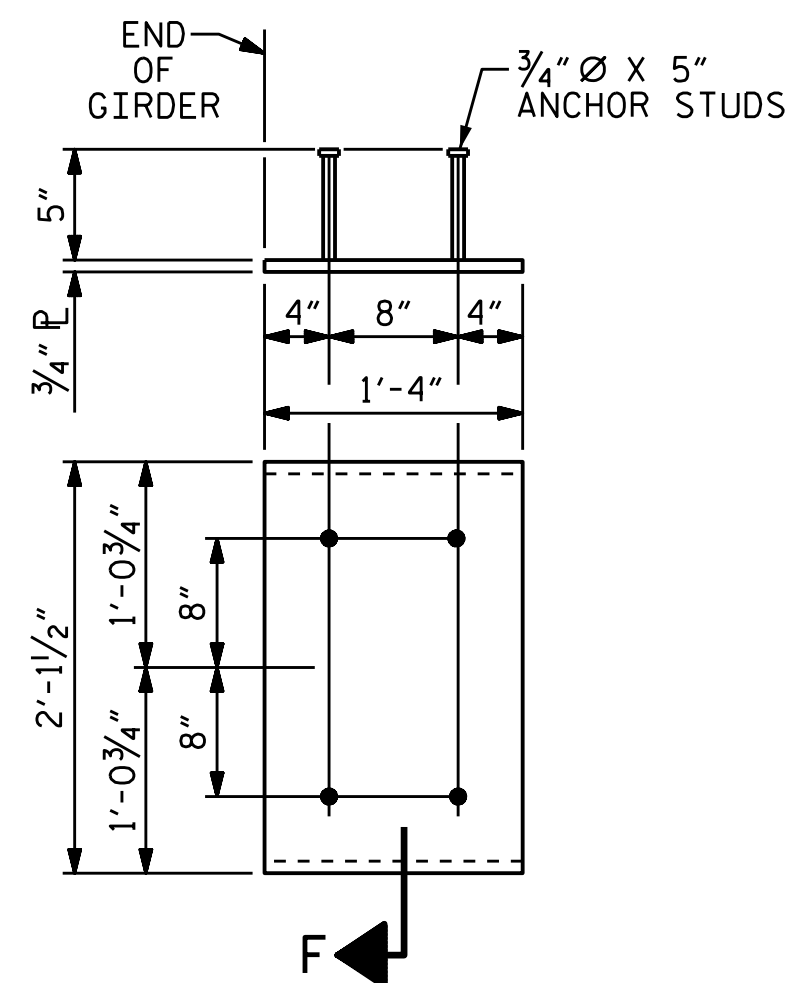

EMBEDDED PLATE "B-1" DETAILS
FOR AASHTO TYPE IV GIRDER
(2 REQ'D PER GIRDER)

NOTES

ALL PRESTRESSING STRANDS SHALL BE 7-WIRE LOW-RELAXATION GRADE 270 STRANDS AND SHALL CONFORM TO AASHTO M203 EXCEPT FOR SAMPLING REQUIREMENTS WHICH SHALL BE IN ACCORDANCE WITH THE STANDARD SPECIFICATIONS.

ALL REINFORCING STEEL SHALL BE GRADE 60.

EMBEDDED PLATE "B-1" SHALL BE GALVANIZED IN ACCORDANCE WITH THE STANDARD SPECIFICATIONS.

ANCHOR STUDS SHALL CONFORM TO AASHTO M169 GRADES 1010 THROUGH 1020 OR APPROVED EQUAL, AND SHALL MEET THE TYPE "B" REQUIREMENTS OF SUBSECTION 7.3 OF THE ANSI/AASHTO/AWS D1.5 BRIDGE WELDING CODE.

AT ENDS OF GIRDERS TO BE EMBEDDED IN CONCRETE DIAPHRAGMS OR END WALLS, PRESTRESSING STRANDS MAY EXTEND A MAXIMUM OF 2" BEYOND THE GIRDER ENDS. OTHERWISE, PRESTRESSING STRANDS SHALL BE CUT FLUSH WITH THE GIRDER ENDS.

THE TRANSFER OF LOAD FROM THE ANCHORAGES TO THE GIRDER SHALL BE DONE WHEN CONCRETE HAS REACHED A COMPRESSIVE STRENGTH OF NOT LESS THAN 4,000 PSI FOR SPAN A AND 5,800 FOR SPANS B AND C.

DEPENDING ON THE TYPE OF SYSTEM USED TO SUPPORT THE DECK SLAB FORMS, PRESET ANCHORS MAY BE NECESSARY IN THE PRESTRESSED CONCRETE GIRDER.

THE TOP SURFACE OF THE GIRDER, EXCLUDING THE OUTSIDE 4", SHALL BE RAKED TO A DEPTH OF 1/4".

FOR EMBEDDED CLIPS FOR PRESTRESSED CONCRETE GIRDERS, SEE SPECIAL PROVISIONS.

DEAD LOAD DEFLECTION TABLE FOR GIRDERS												
0.6" Ø LOW RELAXATION	SPAN A											
	GIRDERS 1 THROUGH 9											
TENTH POINTS	CL BRG.	0.1	0.2	0.3	0.4	0.5	0.6	0.7	0.8	0.9	CL BRG.	
CAMBER (GIRDER ALONE IN PLACE)	↑	0.000	0.014	0.026	0.036	0.042	0.044	0.042	0.036	0.026	0.014	0.000
* DEFLECTION DUE TO SUPERIMPOSED D.L.	↓	0.000	0.010	0.018	0.025	0.029	0.031	0.029	0.025	0.018	0.010	0.000
FINAL CAMBER	↑	0	1/16"	1/8"	1/8"	3/16"	3/16"	3/16"	1/8"	1/8"	1/16"	0

ALL VALUES ARE SHOWN IN FEET (DECIMAL FORM), EXCEPT "FINAL CAMBER", WHICH IS GIVEN IN INCHES (FRACTION FORM).
* INCLUDES FUTURE WEARING SURFACE

DEAD LOAD DEFLECTION TABLE FOR GIRDERS												
0.6" Ø LOW RELAXATION	SPAN B											
	GIRDERS 1 THROUGH 9											
TENTH POINTS	CL BRG.	0.1	0.2	0.3	0.4	0.5	0.6	0.7	0.8	0.9	CL BRG.	
CAMBER (GIRDER ALONE IN PLACE)	↑	0.000	0.054	0.103	0.141	0.165	0.173	0.165	0.141	0.103	0.054	0.000
* DEFLECTION DUE TO SUPERIMPOSED D.L.	↓	0.000	0.040	0.075	0.102	0.120	0.126	0.120	0.102	0.075	0.040	0.000
FINAL CAMBER	↑	0	3/16"	5/16"	7/16"	9/16"	9/16"	9/16"	7/16"	5/16"	3/16"	0

ALL VALUES ARE SHOWN IN FEET (DECIMAL FORM), EXCEPT "FINAL CAMBER", WHICH IS GIVEN IN INCHES (FRACTION FORM).
* INCLUDES FUTURE WEARING SURFACE

DEAD LOAD DEFLECTION TABLE FOR GIRDERS												
0.6" Ø LOW RELAXATION	SPAN C											
	GIRDERS 1 THROUGH 9											
TENTH POINTS	CL BRG.	0.1	0.2	0.3	0.4	0.5	0.6	0.7	0.8	0.9	CL BRG.	
CAMBER (GIRDER ALONE IN PLACE)	↑	0.000	0.054	0.103	0.141	0.165	0.173	0.165	0.141	0.103	0.054	0.000
* DEFLECTION DUE TO SUPERIMPOSED D.L.	↓	0.000	0.038	0.072	0.099	0.116	0.122	0.116	0.099	0.072	0.038	0.000
FINAL CAMBER	↑	0	3/16"	3/8"	1/2"	9/16"	5/8"	9/16"	1/2"	3/8"	3/16"	0

ALL VALUES ARE SHOWN IN FEET (DECIMAL FORM), EXCEPT "FINAL CAMBER", WHICH IS GIVEN IN INCHES (FRACTION FORM).
* INCLUDES FUTURE WEARING SURFACE

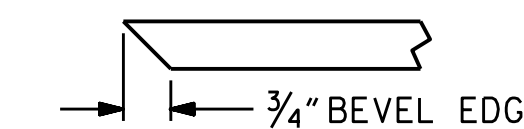

SECTION "F"
(SEE NOTES)

ASSEMBLED BY : J. K. BOWLES	DATE : 2/23/16
CHECKED BY : K. D. LAYNE	DATE : 6/15/16
DRAWN BY : ELR 11/91	REV. 10/1/11 MAA/GM
CHECKED BY : GRP 11/91	REV. 1/15 MAA/TMG
	REV. 2/15 MAA/TMG

01-AUG-2017 11:42
R:\Structures\FINAL PLANS\404.027.U2579C.SMU.DL.014.330703.dgn
mcheck

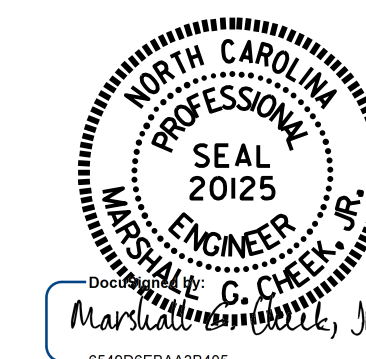

8/1/2017

PROJECT NO. U-2579C
FORSYTH COUNTY
STATION: 473+70.00 -L-

SHEET 4 OF 4

STATE OF NORTH CAROLINA
DEPARTMENT OF TRANSPORTATION
RALEIGH
STANDARD
PRESTRESSED CONCRETE GIRDER
CONTINUOUS FOR LIVE LOAD
DETAILS
(RIGHT LANE)

DOCUMENT NOT CONSIDERED
FINAL UNLESS ALL
SIGNATURES COMPLETED

REVISIONS						SHEET NO.
NO.	BY:	DATE:	NO.	BY:	DATE:	S4-14
1			3			TOTAL SHEETS 33
2			4			

STR. #4 STD. NO. PCG9

STRUCTURAL STEEL NOTES

ALL INTERMEDIATE DIAPHRAGM STEEL AND CONNECTOR PLATES SHALL BE AASHTO M270 GRADE 50 OR APPROVED EQUAL.

TENSION ON THE ASTM A325 BOLTS THROUGH THE CHANNEL MEMBER SHALL BE CALIBRATED USING DIRECT TENSION INDICATOR WASHERS IN ACCORDANCE WITH THE STANDARD SPECIFICATIONS.

TENSION ON THE ASTM A449 BOLTS THROUGH THE GIRDER WEB SHALL BE SNUG TIGHTENED FOLLOWED BY AN ADDITIONAL 1/4 TURN.

THE PLATES, BENT PLATES, CHANNELS, AND ANGLES SHALL BE GALVANIZED OR METALLIZED IN ACCORDANCE WITH THE STANDARD SPECIFICATIONS. FOR THERMAL SPRAYED COATINGS (METALLIZATION), SEE SPECIAL PROVISIONS.

FOR METALLIZATION, APPLY AN 8 MIL THICK 99.99 PERCENT ZINC (W-Zn-1) THERMAL SPRAYED COATING WITH A 0.5 MIL THICK SEAL COAT TO ALL STEEL DIAPHRAGM SURFACES IN ACCORDANCE WITH THE THERMAL SPRAYED COATINGS SPECIAL PROVISION AND SECTION 442 OF THE STANDARD SPECIFICATIONS.

GALVANIZE THE HIGH STRENGTH BOLTS, NUTS, WASHERS AND DIRECT TENSION INDICATORS IN ACCORDANCE WITH THE STANDARD SPECIFICATIONS.

USE AN ASTM F436 HARDENED WASHER WITH STANDARD AND SLOTTED HOLES UNDER EACH BOLT HEAD AND NUT.

FOR BOLTS THROUGH THE GIRDER WEB, PROVIDE SUFFICIENT LENGTH OF THREADS ON ALL BOLTS TO ACCOMMODATE WASHERS AND THE THICKNESS OF CONNECTING MEMBER PLUS AT LEAST 1/4" PROJECTION BEYOND THE NUT.

INTERMEDIATE DIAPHRAGM ASSEMBLY SHALL COMPLY WITH SECTION 1072 OF THE STANDARD SPECIFICATIONS.

SUBMIT TWO SETS OF WORKING DRAWINGS FOR THE INTERMEDIATE DIAPHRAGM ASSEMBLY FOR REVIEW, COMMENTS AND ACCEPTANCE. AFTER REVIEW, COMMENTS, AND ACCEPTANCE, SUBMIT SEVEN SETS FOR DISTRIBUTION.

IN THE EXTERIOR BAYS, PLACE TEMPORARY STRUTS BETWEEN PRESTRESSED GIRDERS ADJACENT TO THE STEEL DIAPHRAGMS. STRUTS SHALL REMAIN IN PLACE 3 DAYS AFTER CONCRETE IS PLACED.

THE COST OF THE STEEL DIAPHRAGMS AND ASSEMBLIES SHALL BE INCLUDED IN THE UNIT PRICE BID FOR 54" PRESTRESSED CONCRETE GIRDERS.

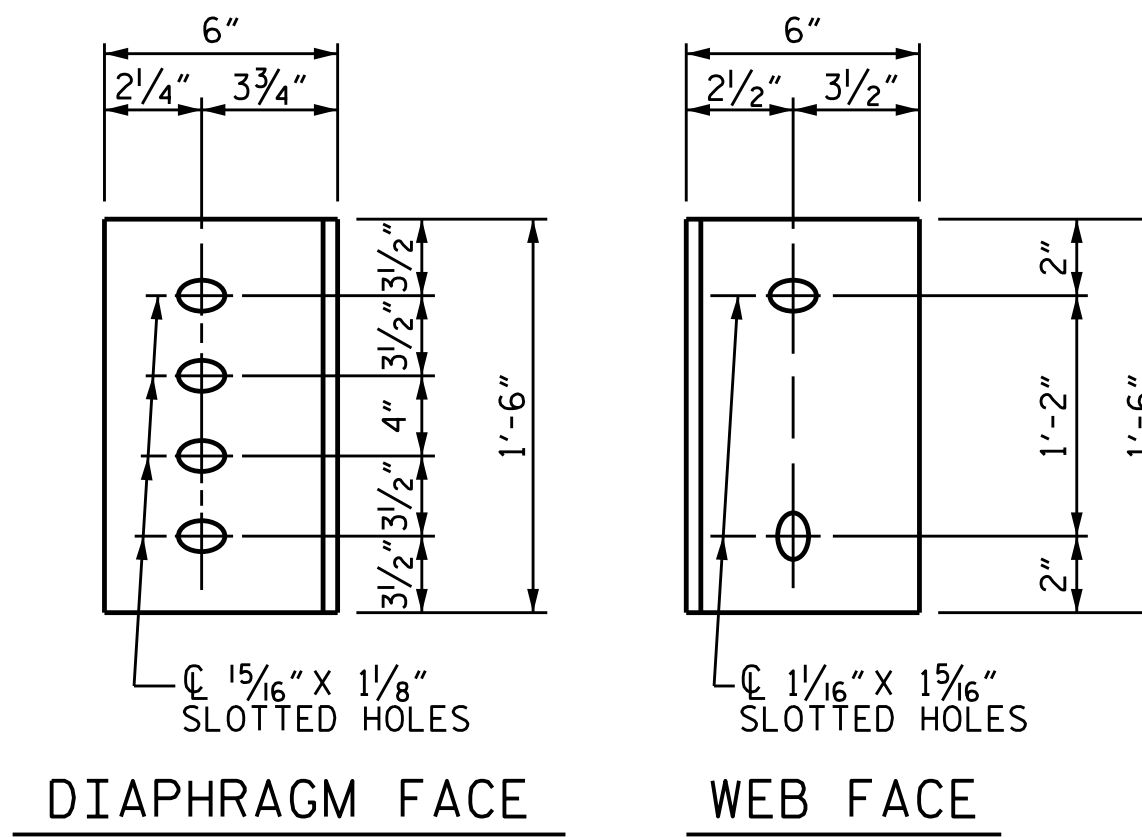

CONNECTOR PLATE DETAILS

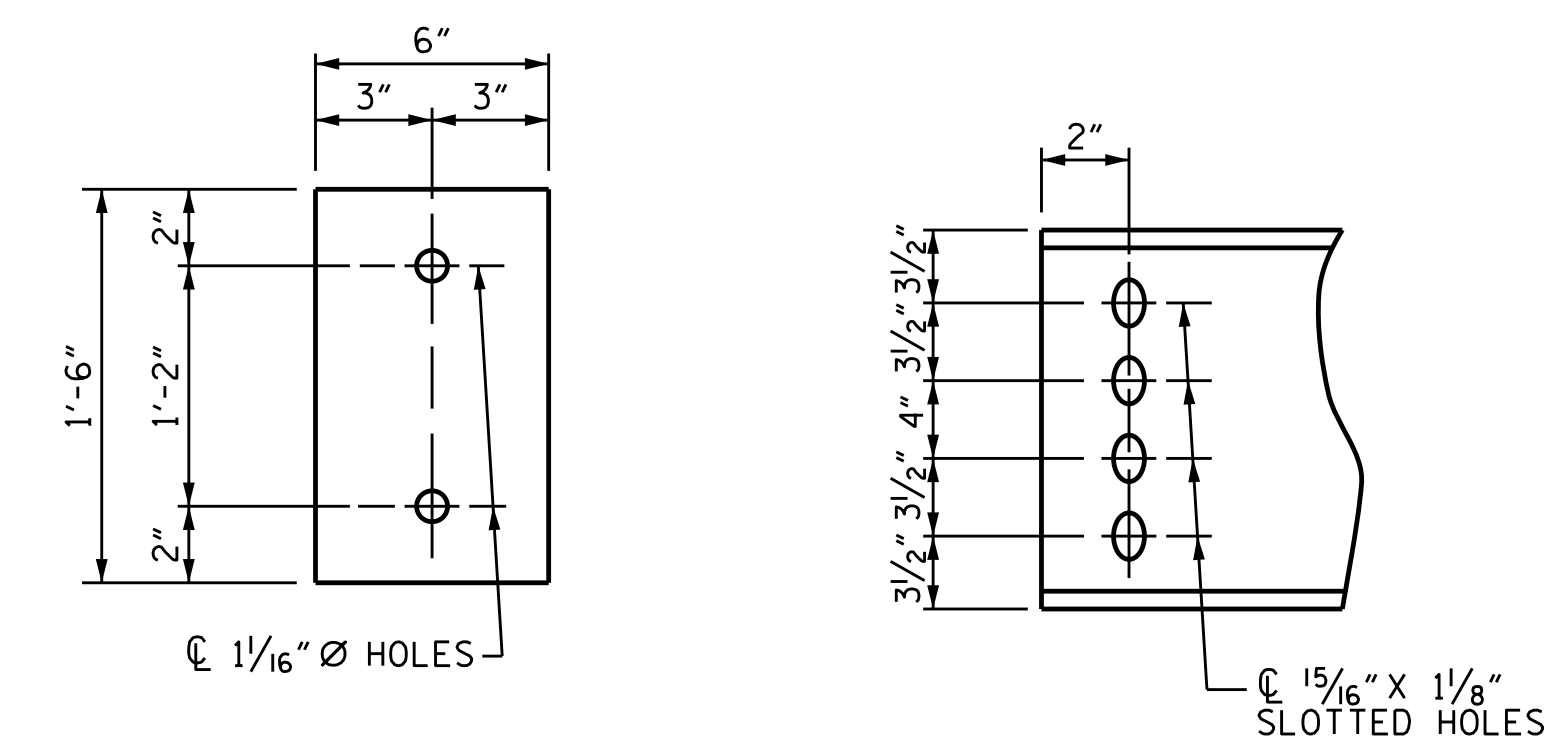
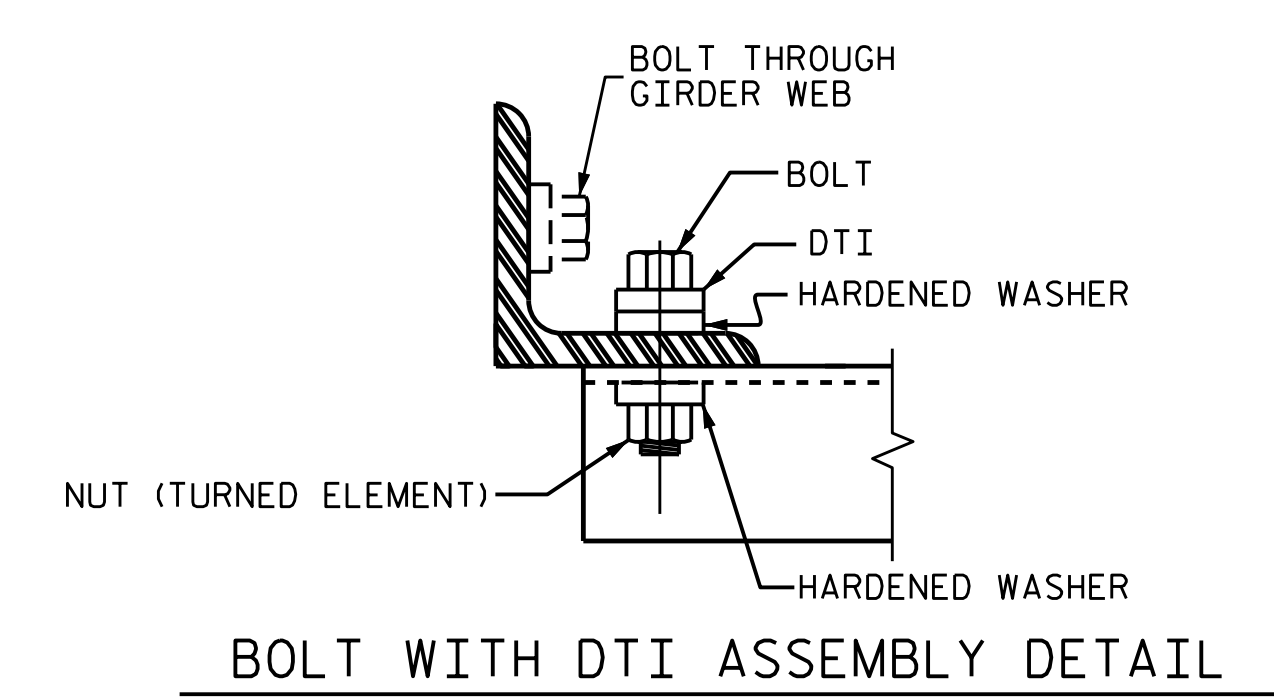
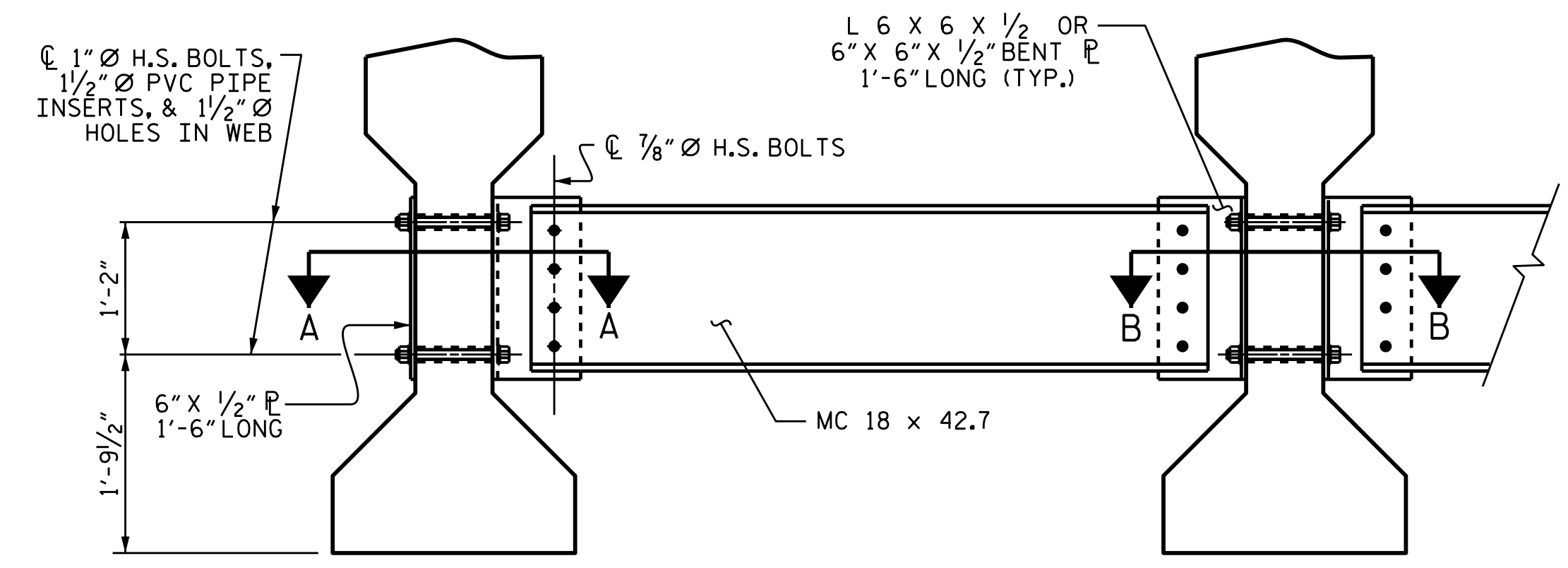

PLATE DETAILS **CHANNEL END**



BOLT WITH DTI ASSEMBLY DETAIL



EXTERIOR GIRDER **INTERIOR GIRDER**

PART SECTION AT INTERMEDIATE DIAPHRAGM

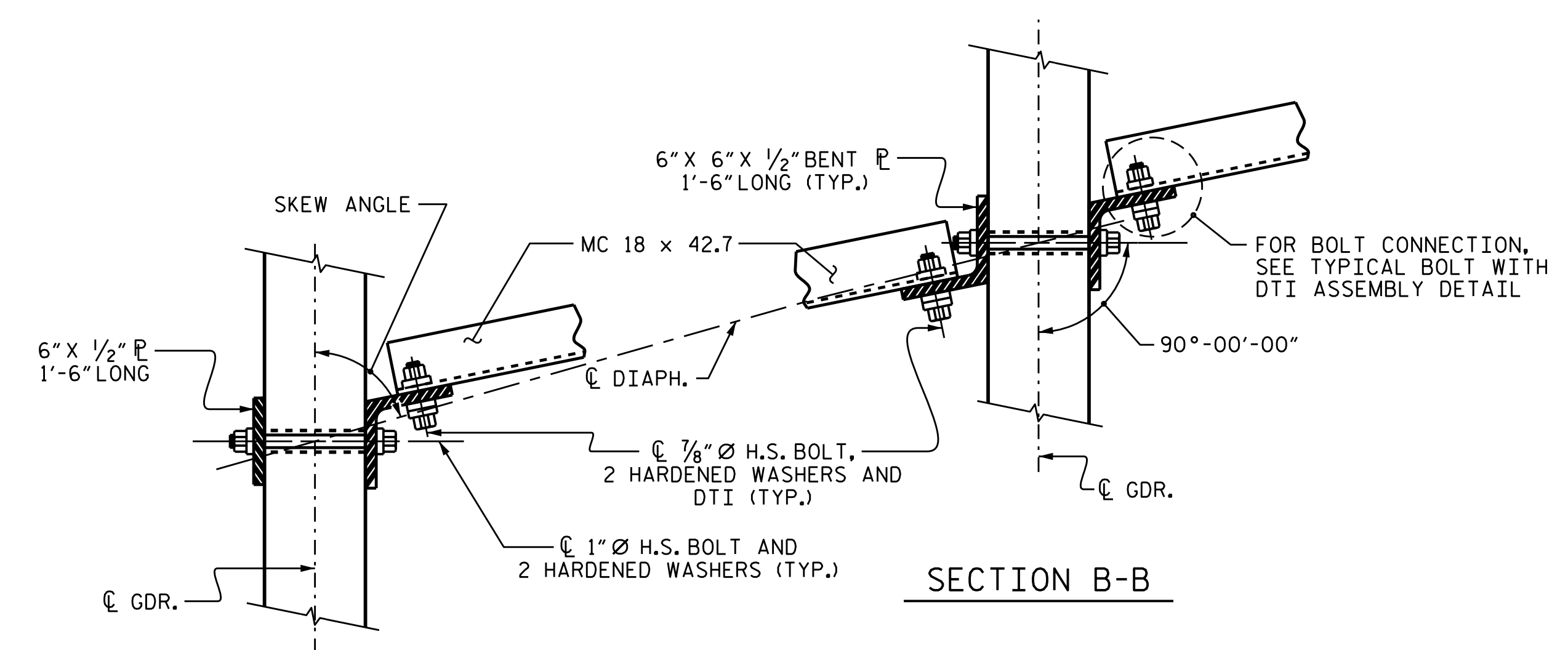

SECTION A-A

SECTION B-B

CONNECTION DETAILS

PROJECT NO. U-2579C
FORSYTH COUNTY
 STATION: 473+70.00 -L-



STATE OF NORTH CAROLINA
 DEPARTMENT OF TRANSPORTATION
 RALEIGH
 STANDARD
 INTERMEDIATE
 STEEL DIAPHRAGMS
 FOR TYPE IV PRESTRESSED
 CONCRETE GIRDERS
 (RIGHT LANE)

ASSEMBLED BY : H. A. LOCKLEAR	DATE : 10-15
CHECKED BY : K. D. LAYNE	DATE : 6/15/16
DRAWN BY : TLA 6/05	ADDED 10/21/05
CHECKED BY : VC 6/05	REV. 5/1/06RRR KMM/GM
	REV. 10/1/11 MAA/GM

DOCUMENT NOT CONSIDERED FINAL UNLESS ALL SIGNATURES COMPLETED

REVISIONS						SHEET NO.
NO.	BY:	DATE:	NO.	BY:	DATE:	S4-15
1			3			TOTAL SHEETS
2			4			33

NOTES

AT ALL FIXED POINTS OF SUPPORT, NUTS FOR ANCHOR BOLTS ARE TO BE TIGHTENED FINGER TIGHT AND THEN BACKED OFF 1/2 TURN. THE THREAD OF THE NUT AND BOLT SHALL THEN BE BURRED WITH A SHARP POINTED TOOL.

STEEL SOLE PLATES, ANCHOR BOLTS, AND NUTS SHALL BE GALVANIZED IN ACCORDANCE WITH THE STANDARD SPECIFICATIONS.

PRIOR TO WELDING, GRIND THE GALVANIZED SURFACE OF THE PORTION OF THE EMBEDDED PLATE AND SOLE PLATE THAT ARE TO BE WELDED. AFTER WELDING, DAMAGED GALVANIZED SURFACES SHALL BE REPAIRED IN ACCORDANCE WITH THE STANDARD SPECIFICATIONS.

WHEN WELDING THE SOLE PLATE TO THE EMBEDDED PLATE IN THE GIRDER, USE TEMPERATURE INDICATING WAX PENS, OR OTHER SUITABLE MEANS, TO ENSURE THAT THE TEMPERATURE OF THE SOLE PLATE DOES NOT EXCEED 300°F. TEMPERATURES ABOVE THIS MAY DAMAGE THE ELASTOMER.

SOLE PLATE "P", BOLTS, AND NUTS SHALL BE INCLUDED IN THE PAY ITEM FOR PRESTRESSED CONCRETE GIRDERS.

ANCHOR BOLTS SHALL MEET THE REQUIREMENTS OF ASTM A449. NUTS SHALL MEET THE REQUIREMENTS OF AASHTO M291-DH OR AASHTO M292-2H. NO SHOP DRAWINGS ARE REQUIRED FOR ANCHOR BOLTS AND NUTS. SHOP INSPECTION IS REQUIRED.

ALL SURFACES OF BEARING PLATES SHALL BE SMOOTH AND STRAIGHT.

THE ELASTOMER IN THE STEEL REINFORCED BEARINGS SHALL HAVE A SHEAR MODULUS OF 0.160 KSI, IN ACCORDANCE WITH AASHTO M251.

FOR STEEL REINFORCED ELASTOMERIC BEARINGS, SEE SPECIAL PROVISIONS.

MAXIMUM ALLOWABLE SERVICE LOADS	
D.L.+L.L. (NO IMPACT)	
TYPE IV	225 k
TYPE V	365 k

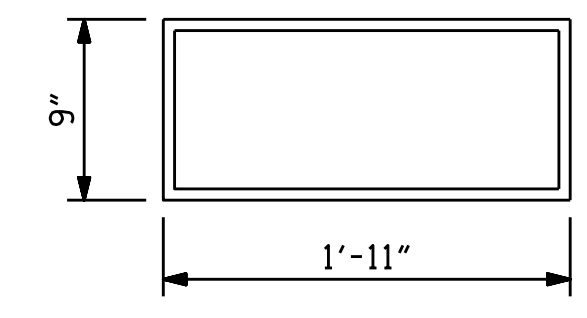
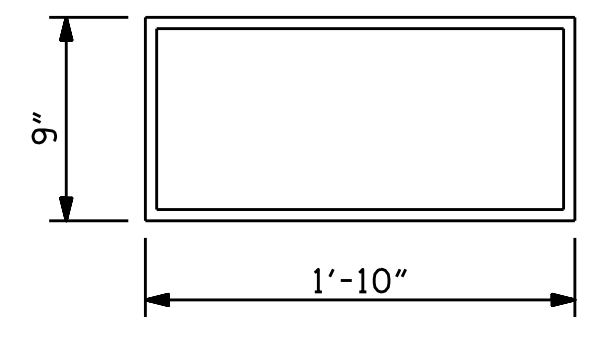
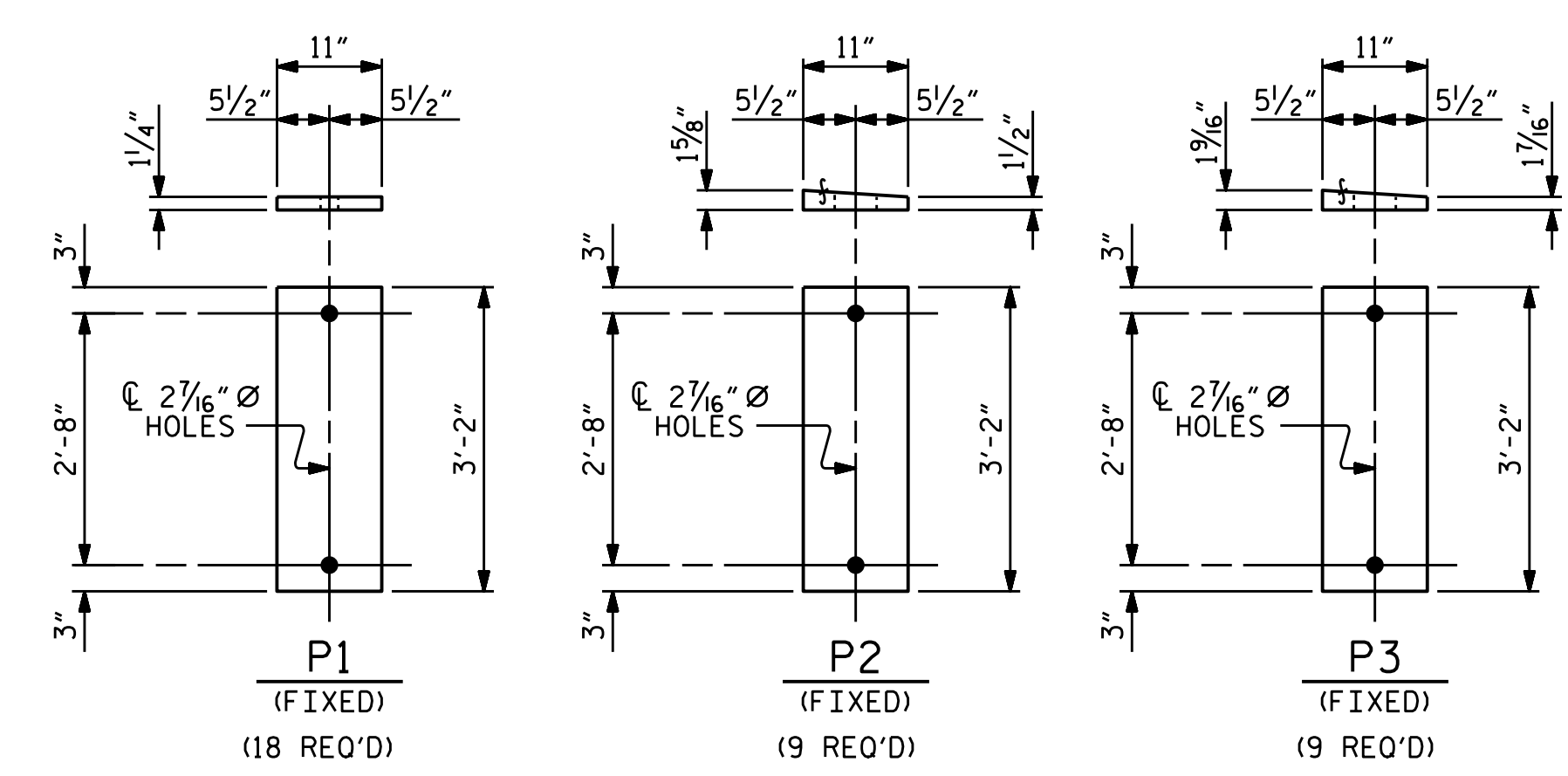
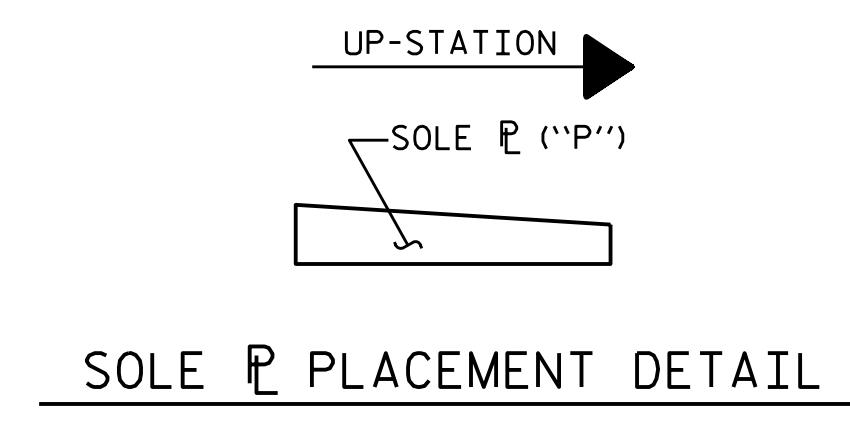
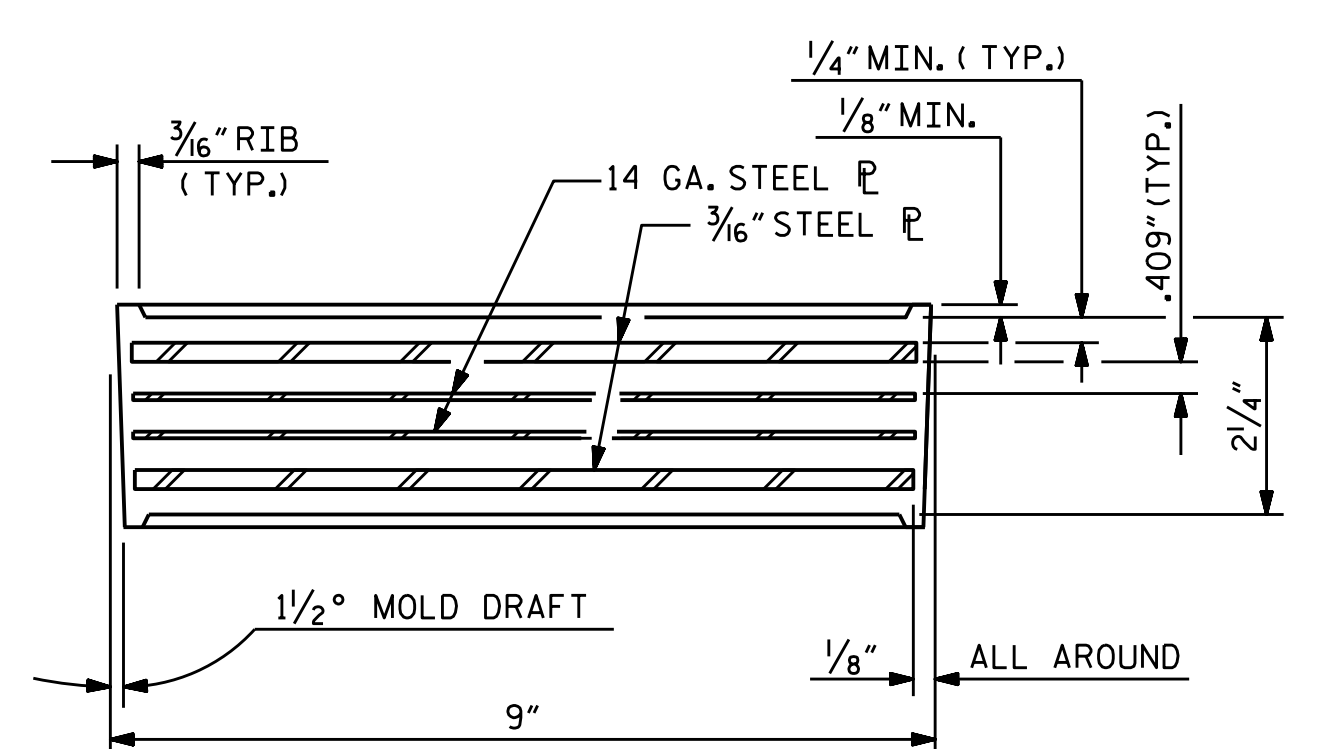
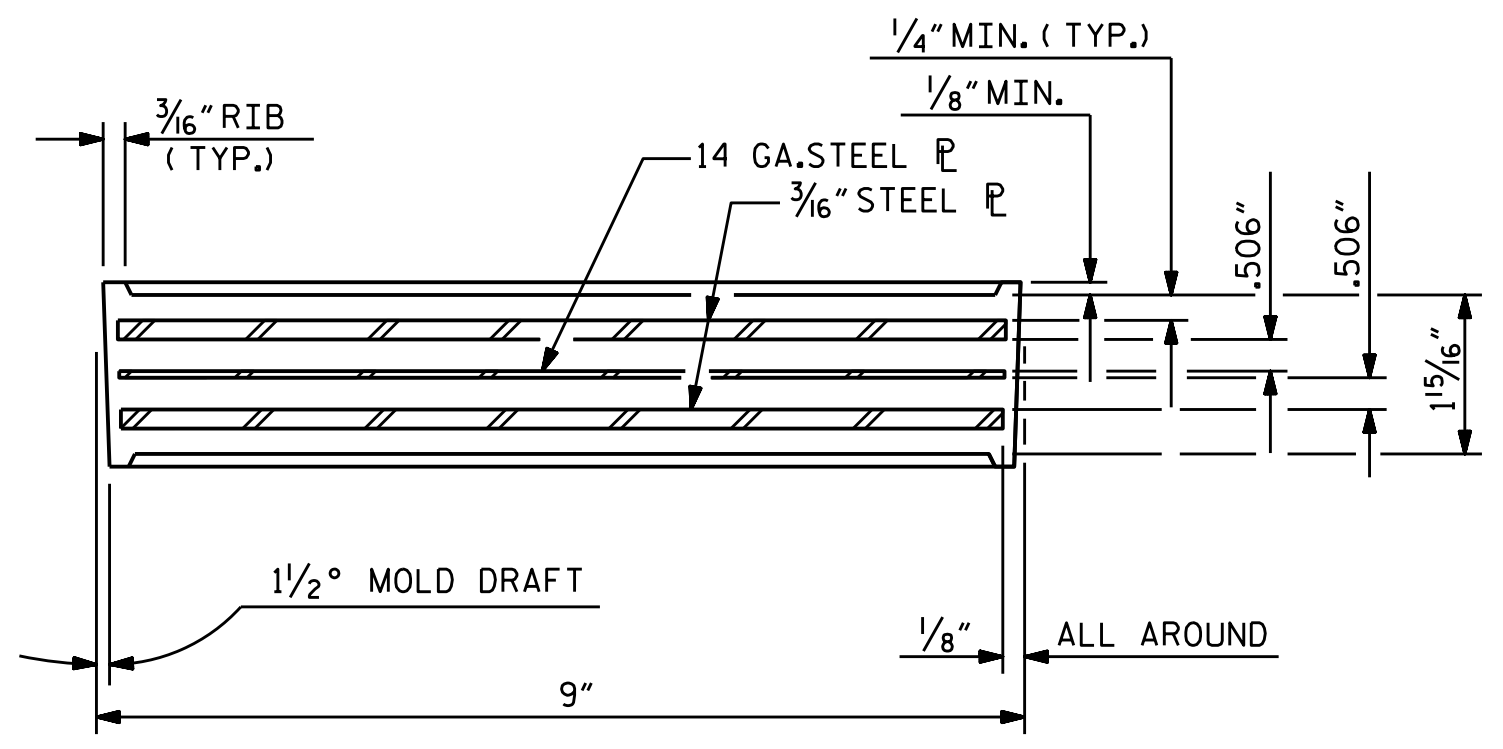
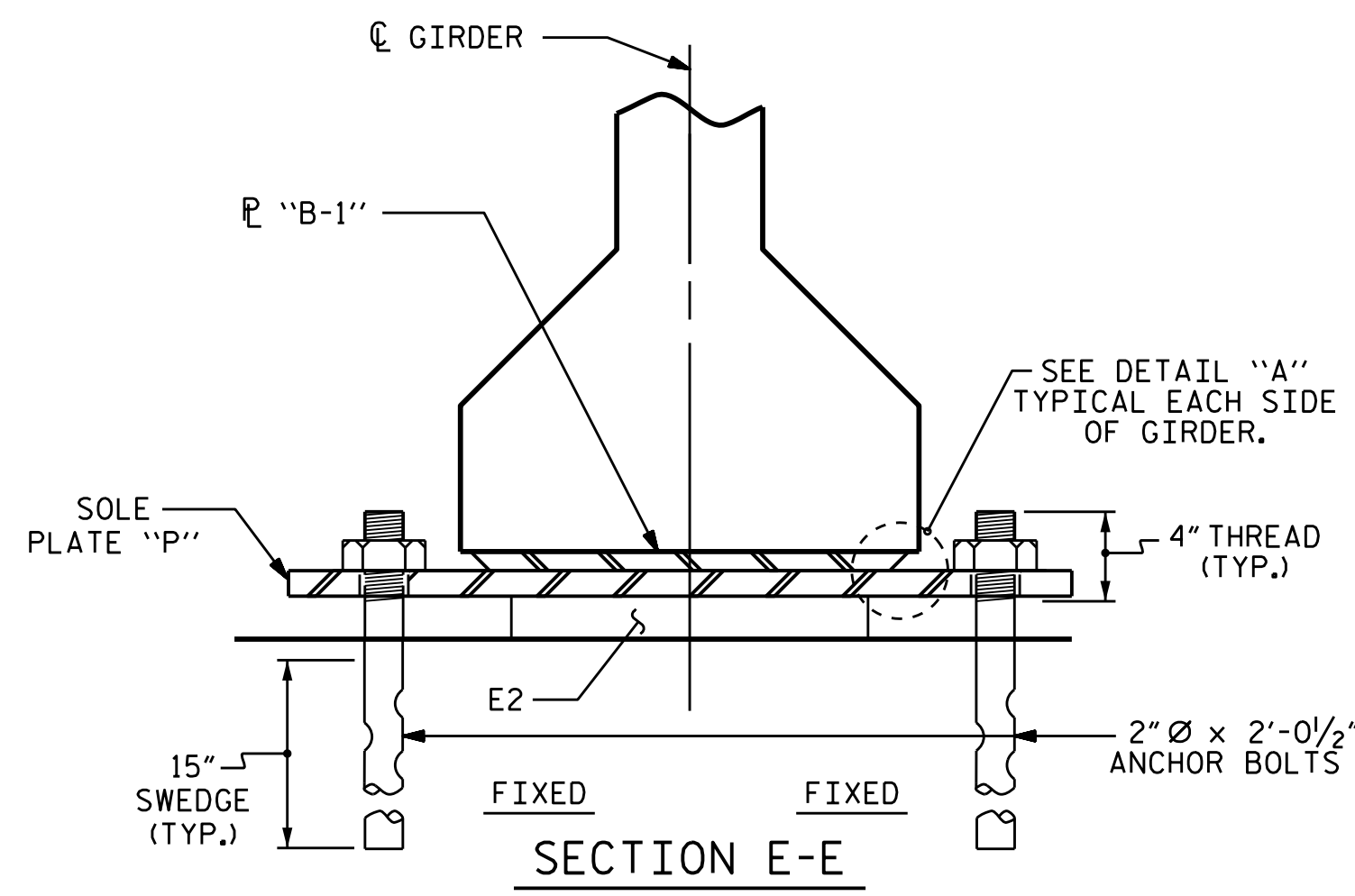
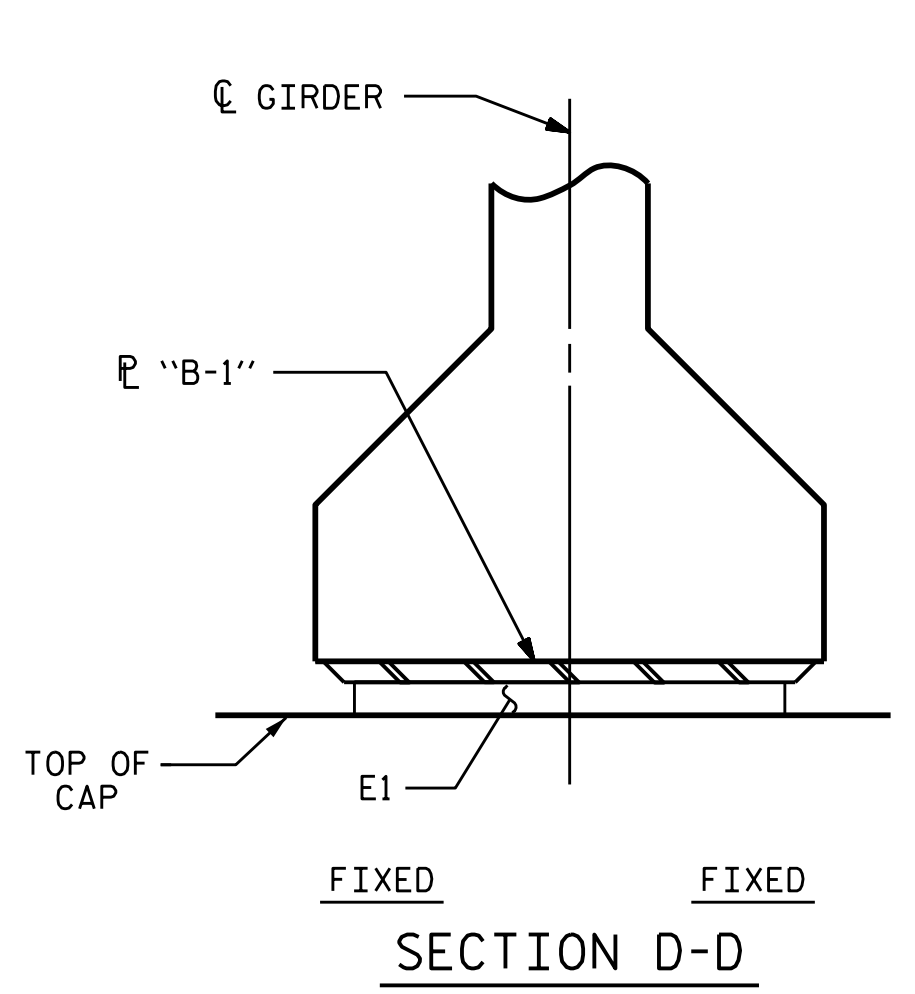

E1 (18 REQ'D)
PLAN VIEW OF ELASTOMERIC BEARING
TYPE IV

E2 (36 REQ'D)
PLAN VIEW OF ELASTOMERIC BEARING
TYPE V

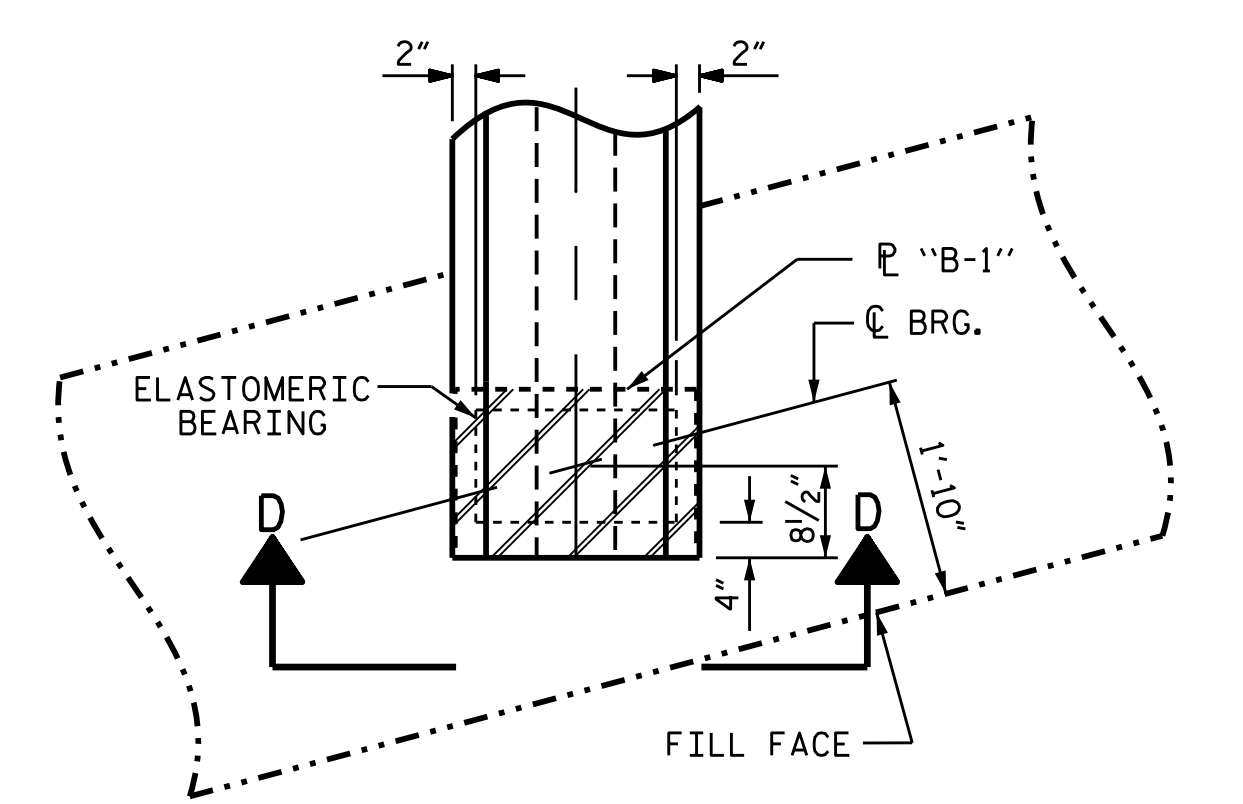

PLAN VIEW AT INTEGRAL END BENT

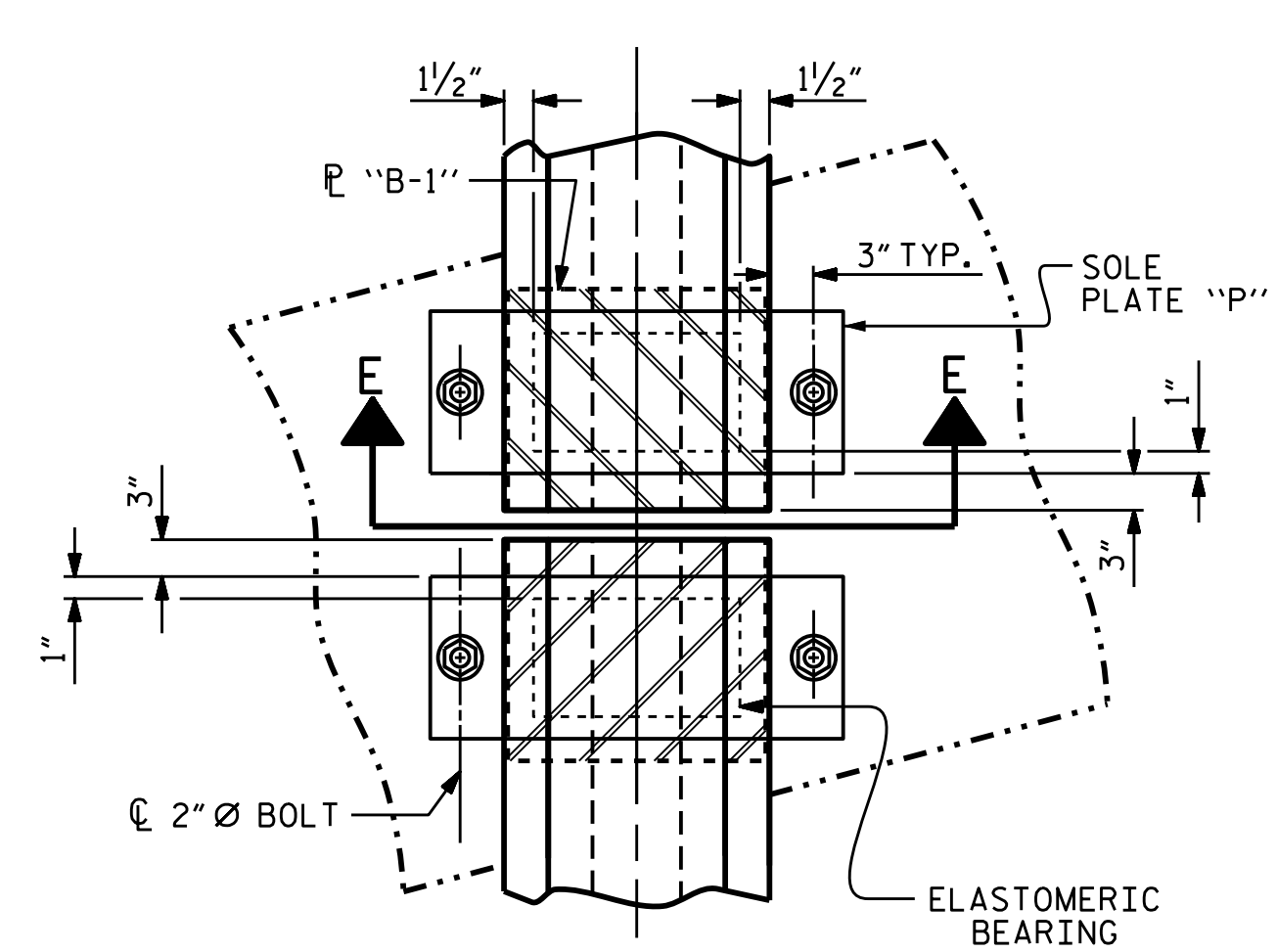

PLAN VIEW AT BENT
(SHOWING CONTINUOUS BENT)

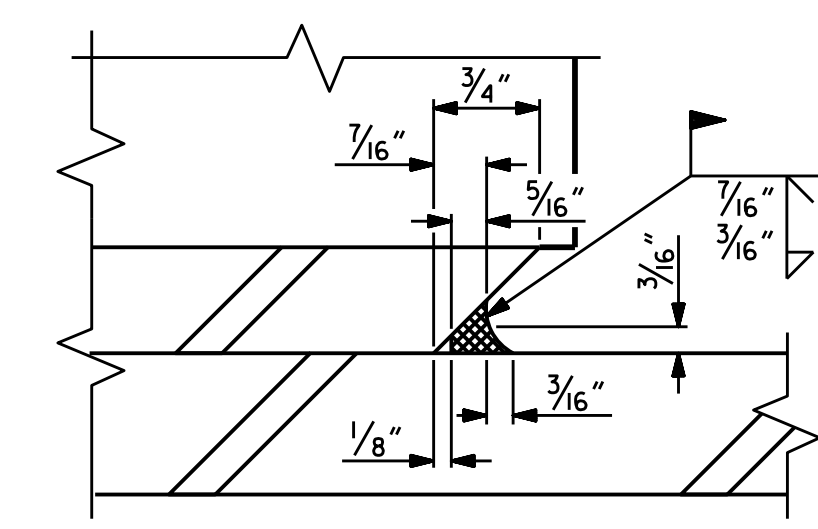

DETAIL "A"



PROJECT NO. U-2579C
FORSYTH COUNTY
 STATION: 473+70.00 -L-

STATE OF NORTH CAROLINA
 DEPARTMENT OF TRANSPORTATION
 RALEIGH
 STANDARD
ELASTOMERIC BEARING
 DETAILS
 PRESTRESSED CONCRETE GIRDER
 SUPERSTRUCTURE
 (RIGHT LANE)

ASSEMBLED BY : J. K. BOWLES	DATE : 4/14/16
CHECKED BY : K. D. LAYNE	DATE : 6/15/16
DRAWN BY : EEM 2/97	REV. 10/1/11 MAA/GM
CHECKED BY : VAP 2/97	REV. 6/13 AAC/MAA
	REV. 1/15 MAA/TMG

DOCUMENT NOT CONSIDERED FINAL UNLESS ALL SIGNATURES COMPLETED

REVISIONS						SHEET NO.	
NO.	BY:	DATE:	NO.	BY:	DATE:	S4-16	
1			3			TOTAL SHEETS 33	
2			4				

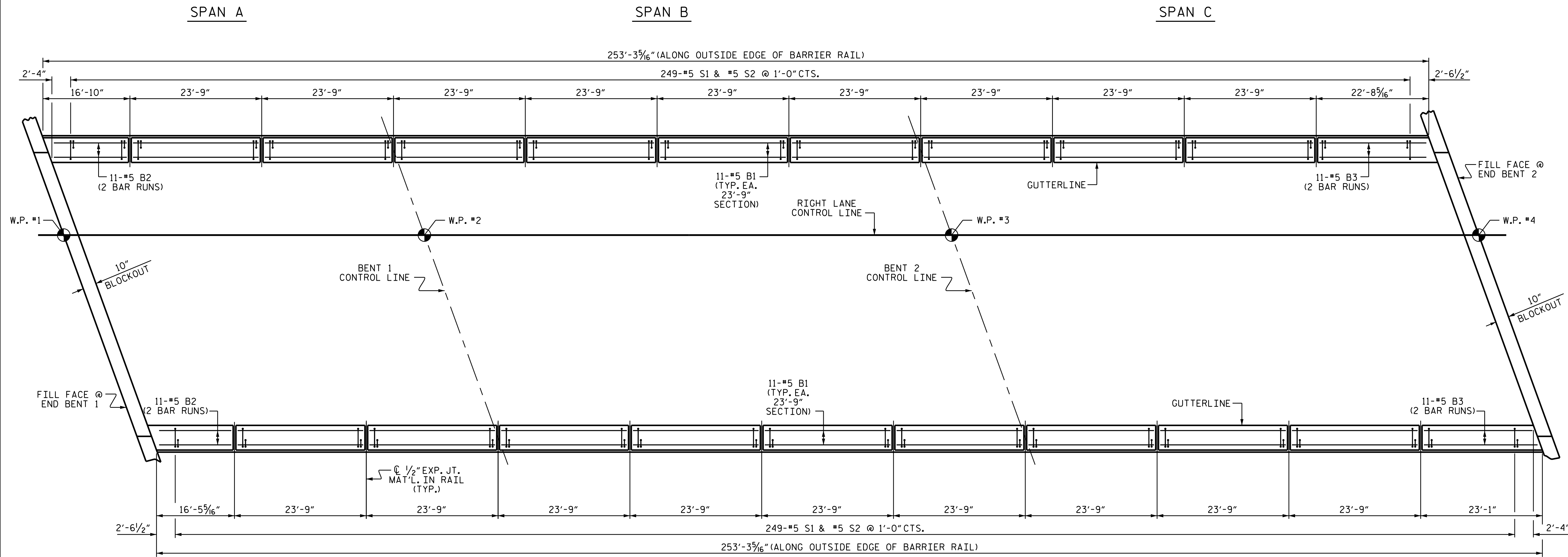

PLAN OF CONCRETE BARRIER RAIL

PROJECT NO. U-2579C
 FORSYTH COUNTY
 STATION: 473+70.00 -L-

SHEET 1 OF 2



STATE OF NORTH CAROLINA
 DEPARTMENT OF TRANSPORTATION
 RALEIGH

3'-6" CONCRETE BARRIER RAIL
 (RIGHT LANE)

DRAWN BY : T. L. AVERETTE DATE : 3/02/17
 CHECKED BY : H. T. BARBOUR DATE : 3/14/17

REVISIONS						SHEET NO.
NO.	BY:	DATE:	NO.	BY:	DATE:	TOTAL SHEETS
1			3			S4-17
2			4			33

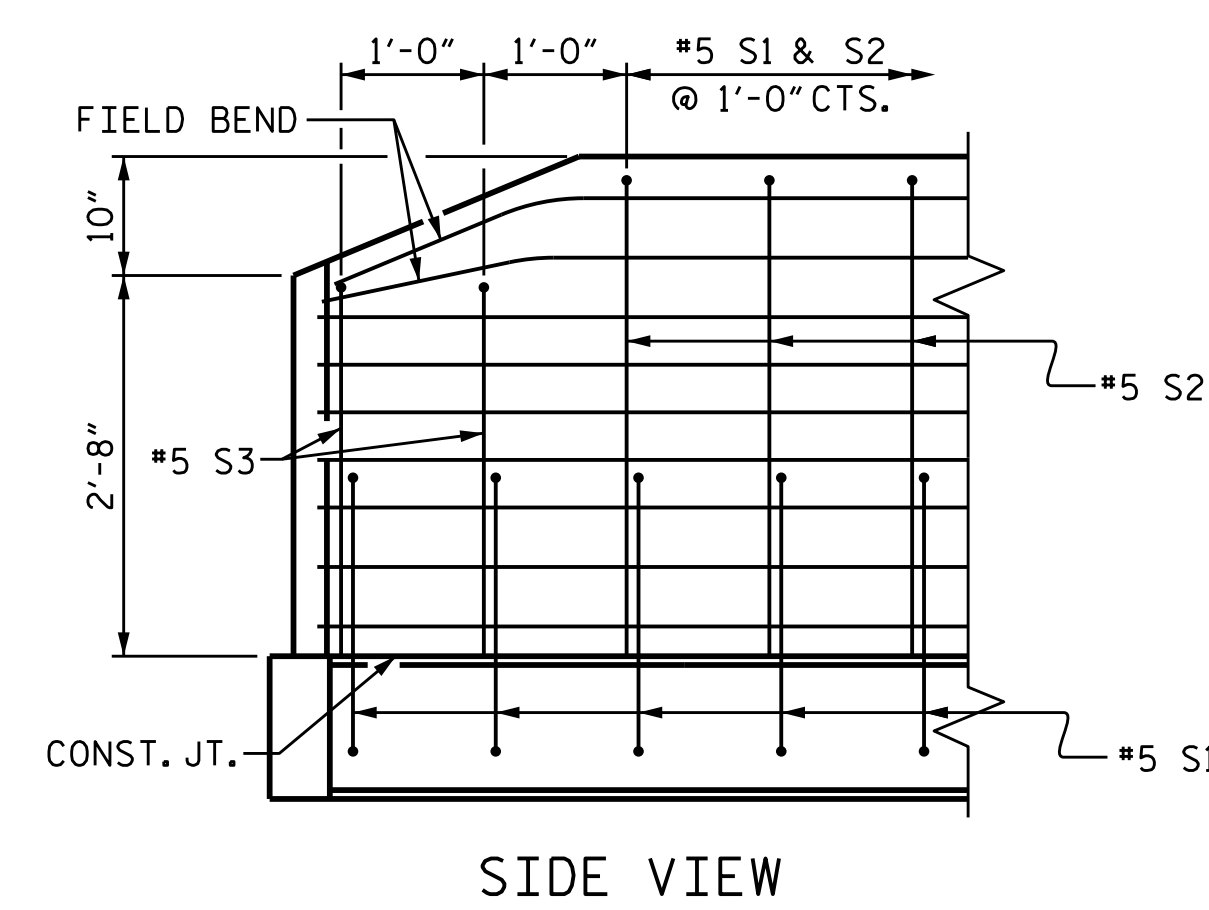
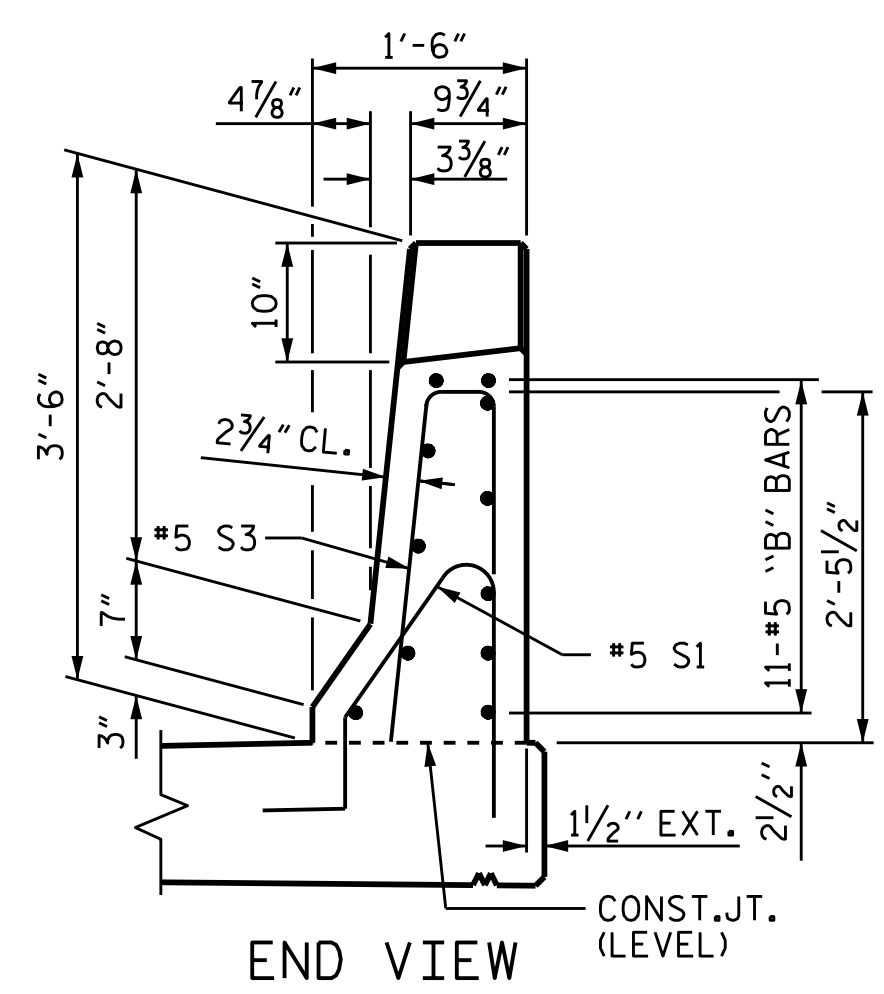
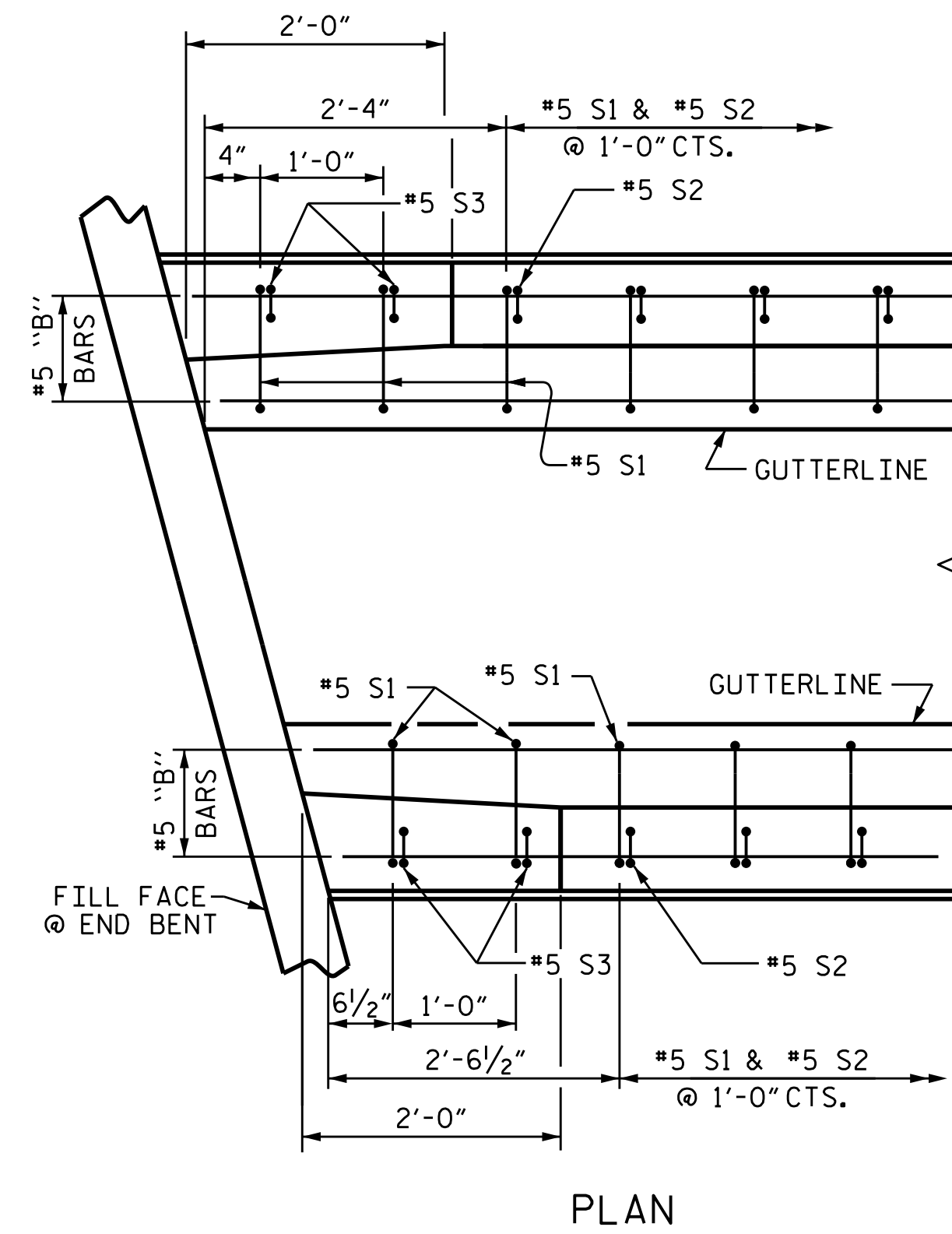

END OF RAIL DETAILS

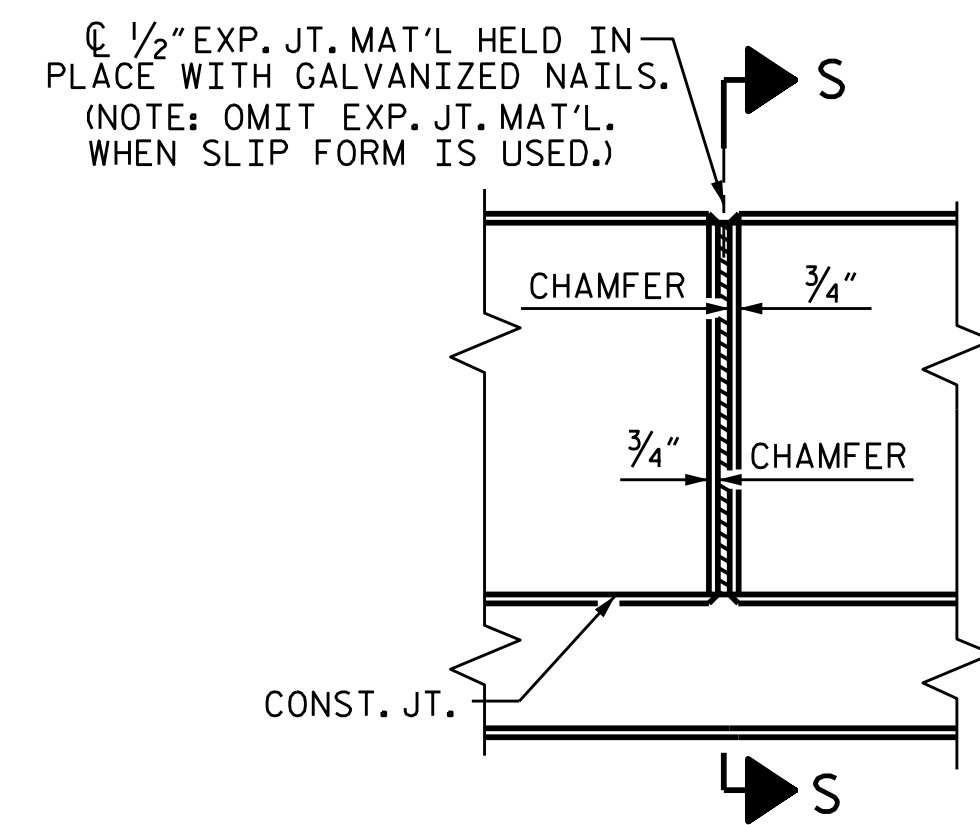
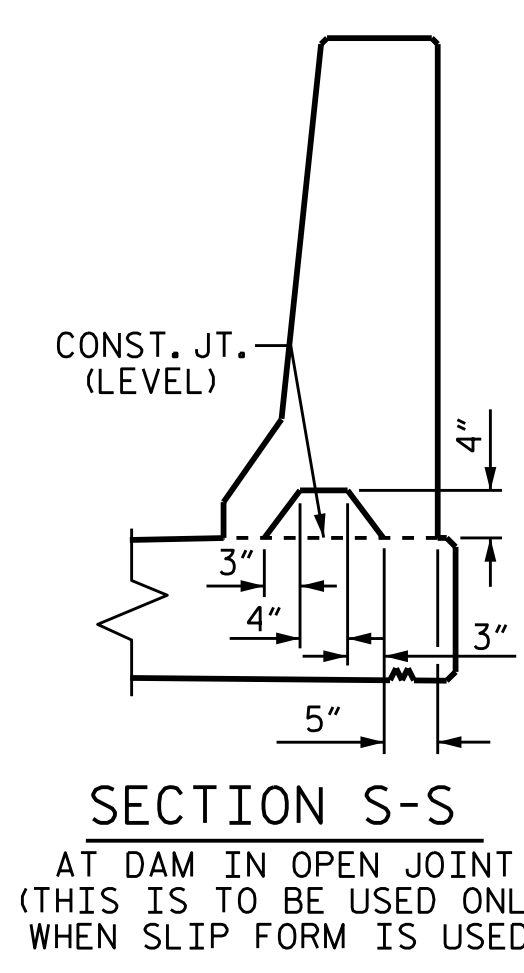
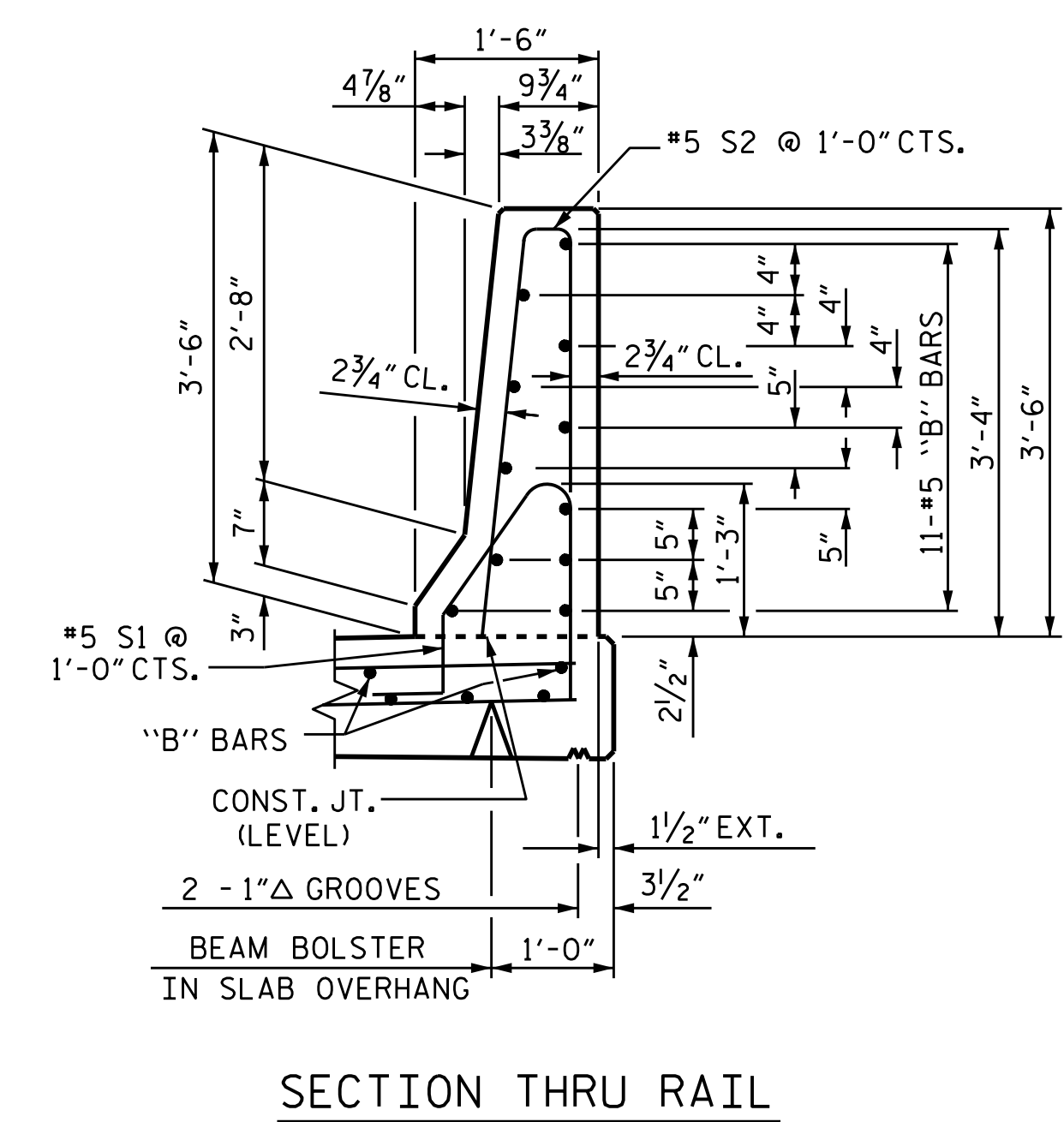

SECTION THRU RAIL

ELEVATION AT EXPANSION JOINTS

BARRIER RAIL DETAILS

NOTES

THE BARRIER RAIL IN THE CONTINUOUS UNIT SHALL NOT BE CAST UNTIL ALL SLAB CONCRETE IN THAT UNIT HAS BEEN CAST AND HAS REACHED A MINIMUM COMPRESSIVE STRENGTH OF 3,000 PSI.

ALL REINFORCING STEEL IN BARRIER RAILS SHALL BE EPOXY COATED.

GROOVED CONTRACTION JOINTS, 1/2" IN DEPTH, SHALL BE TOOLED IN ALL EXPOSED FACES OF THE BARRIER RAIL AND IN ACCORDANCE WITH ARTICLE 825-10(B) OF THE STANDARD SPECIFICATIONS, THE CONTRACTION JOINT SHALL BE LOCATED AT EACH THIRD POINT BETWEEN BARRIER RAIL EXPANSION JOINTS. ONLY ONE CONTRACTION JOINT IS REQUIRED AT MIDPOINT OF BARRIER RAIL SEGMENTS LESS THAN 20 FEET IN LENGTH AND NO CONTRACTION JOINTS ARE REQUIRED FOR THOSE SEGMENTS LESS THAN 10 FEET IN LENGTH.

THE #5 S1 AND #5 S2 BARS MAY BE SHIFTED SLIGHTLY IN ORDER TO MAINTAIN 2" MINIMUM CLEARANCE TO THE 1/2" EXPANSION JOINT MATERIAL IN THE BARRIER RAIL.

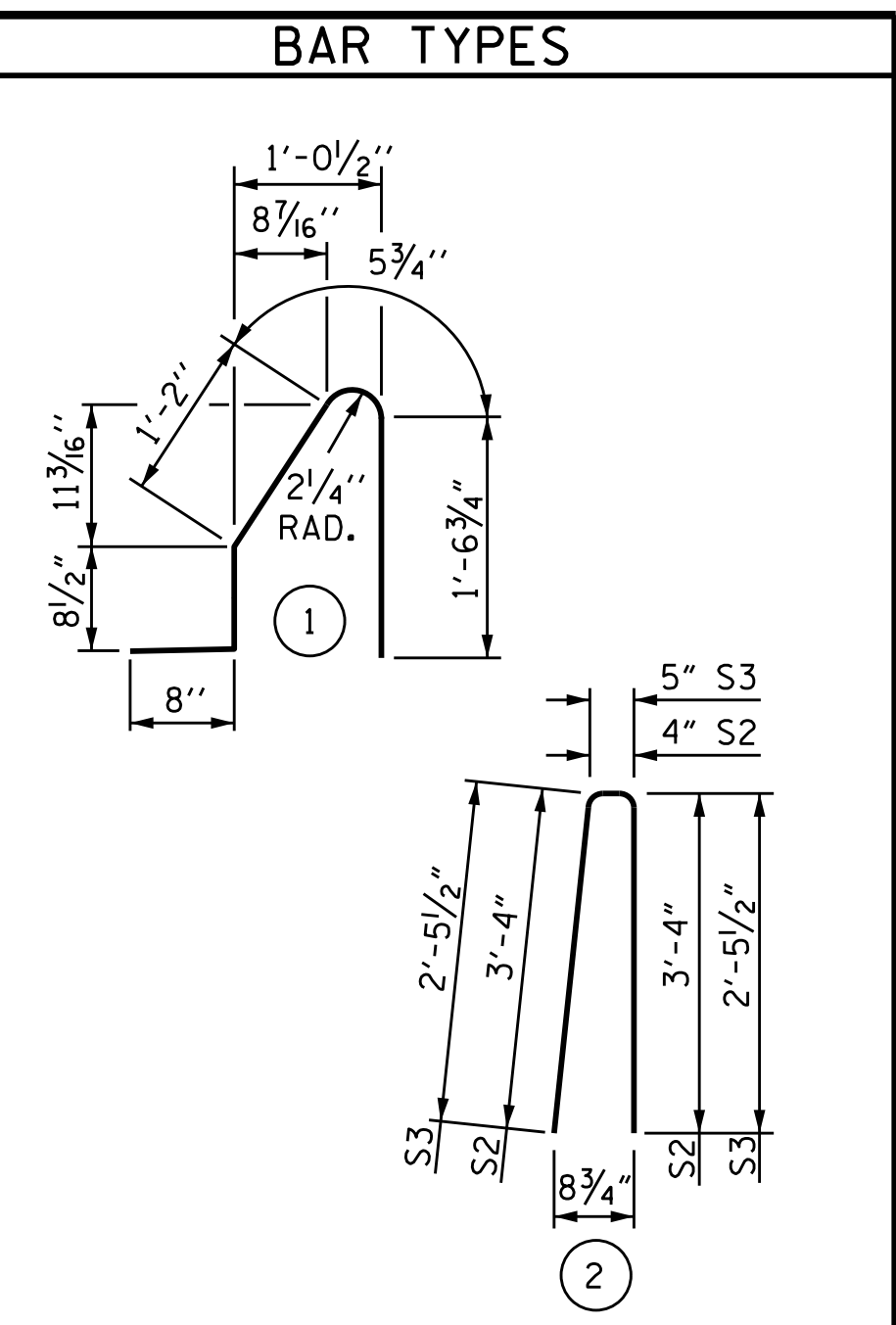

ALL BAR DIMENSIONS ARE OUT TO OUT.

BILL OF MATERIAL					
FOR CONCRETE BARRIER RAIL ONLY					
BAR	NO.	SIZE	TYPE	LENGTH	WEIGHT
* B1	198	#5	STR	23'-4"	4819
* B2	44	#5	STR	9'-11"	455
* B3	44	#5	STR	13'-1"	600
* S1	506	#5	1	4'-7"	2419
* S2	498	#5	2	7'-0"	3636
* S3	8	#5	2	5'-4"	45
* EPOXY COATED REINFORCING STEEL					LBS. 11,974
CLASS AA CONCRETE					C.Y. 68.9
CONCRETE BARRIER RAIL					LIN. FT. 506.55

PROJECT NO. U-2579C
 FORSYTH COUNTY
 STATION: 473+70.00 -L-

SHEET 2 OF 2

STATE OF NORTH CAROLINA
 DEPARTMENT OF TRANSPORTATION
 RALEIGH

3'-6" CONCRETE BARRIER RAIL
 (RIGHT LANE)



DRAWN BY: T. L. AVERETTE DATE: 3/02/17
 CHECKED BY: H. T. BARBOUR DATE: 3/14/17
 DESIGN ENGINEER OF RECORD: H. A. LOCKLEAR DATE: 6/2017

DOCUMENT NOT CONSIDERED FINAL UNLESS ALL SIGNATURES COMPLETED

REVISIONS						SHEET NO.
NO.	BY:	DATE:	NO.	BY:	DATE:	S4-18
1			3			TOTAL SHEETS
2			4			33

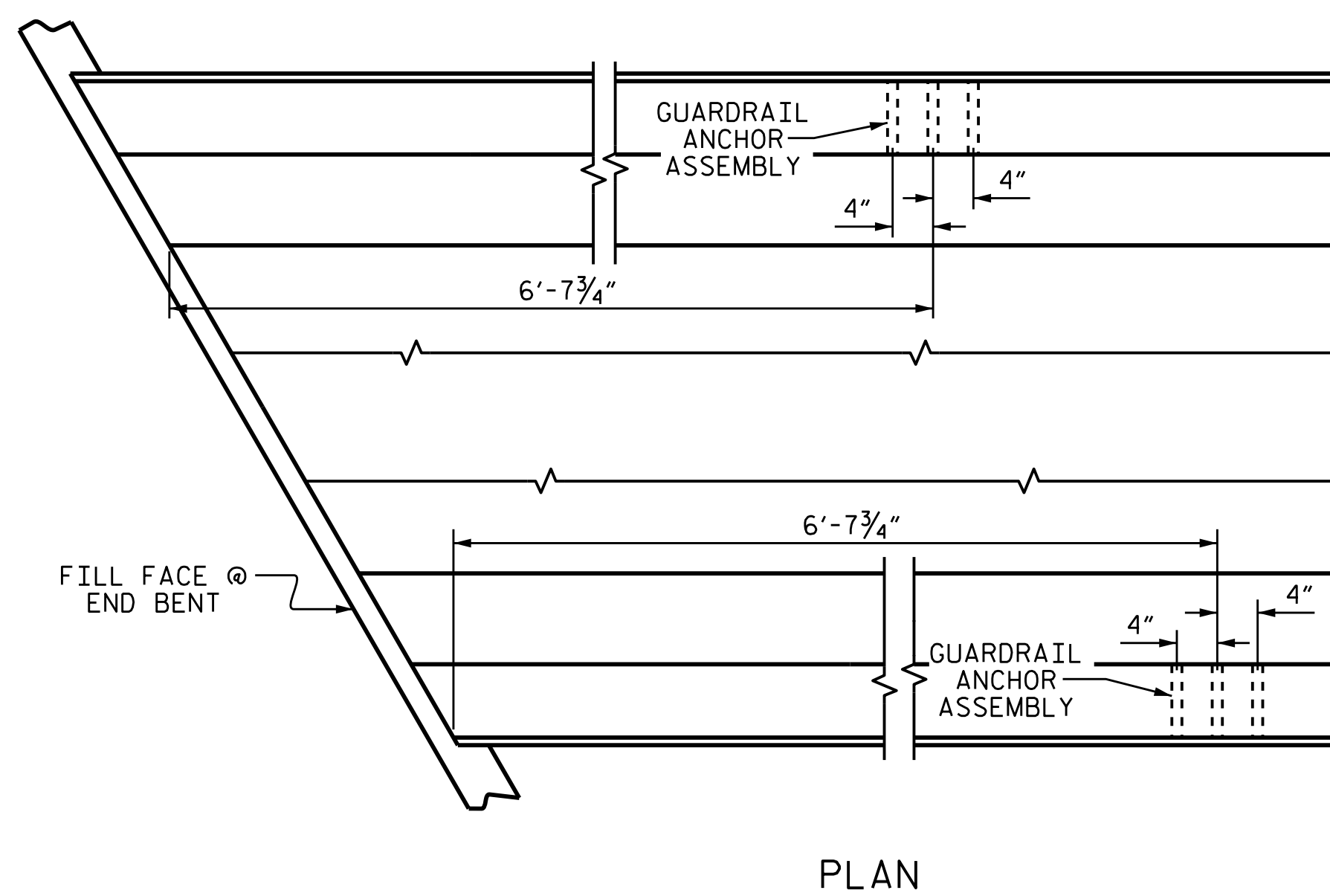
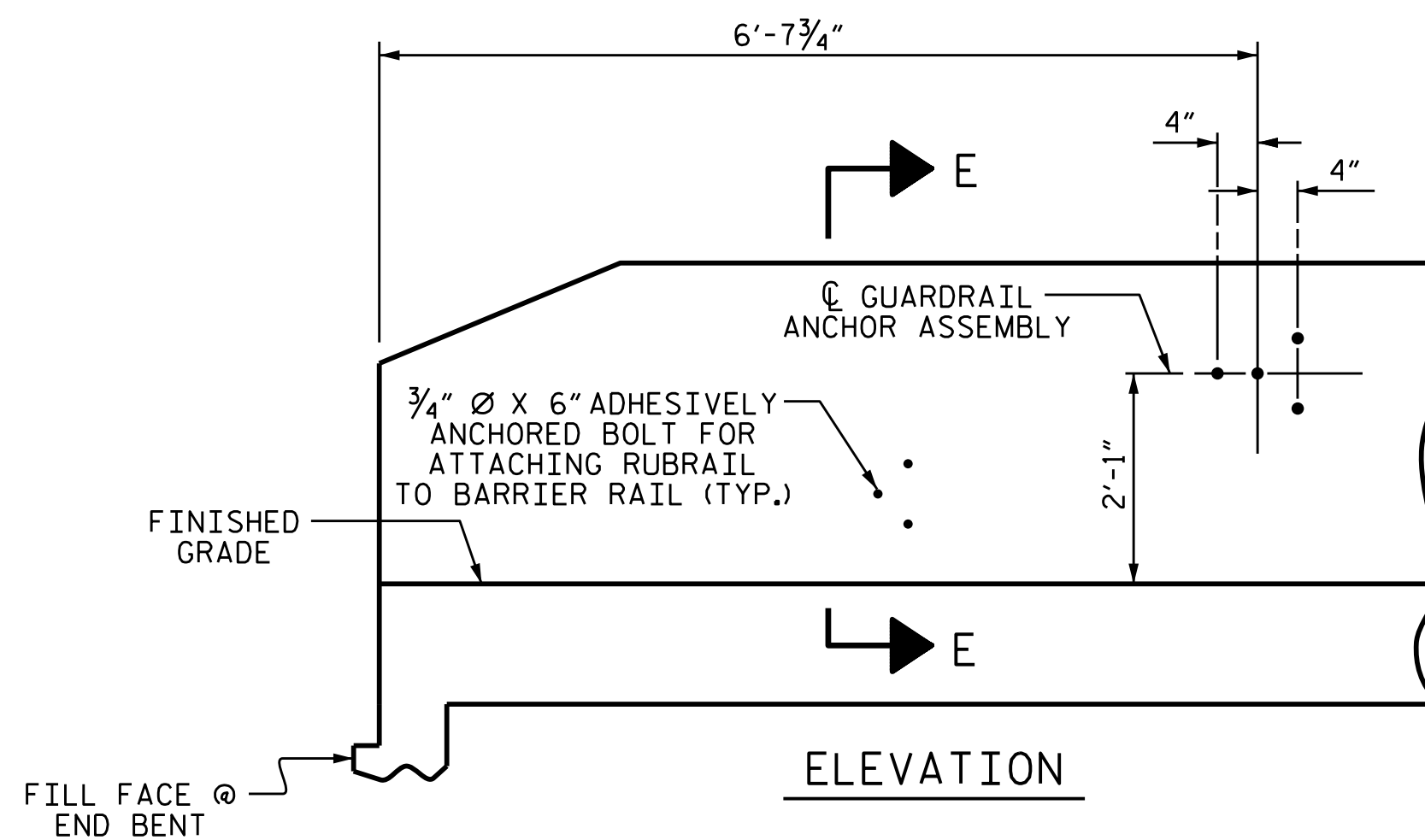
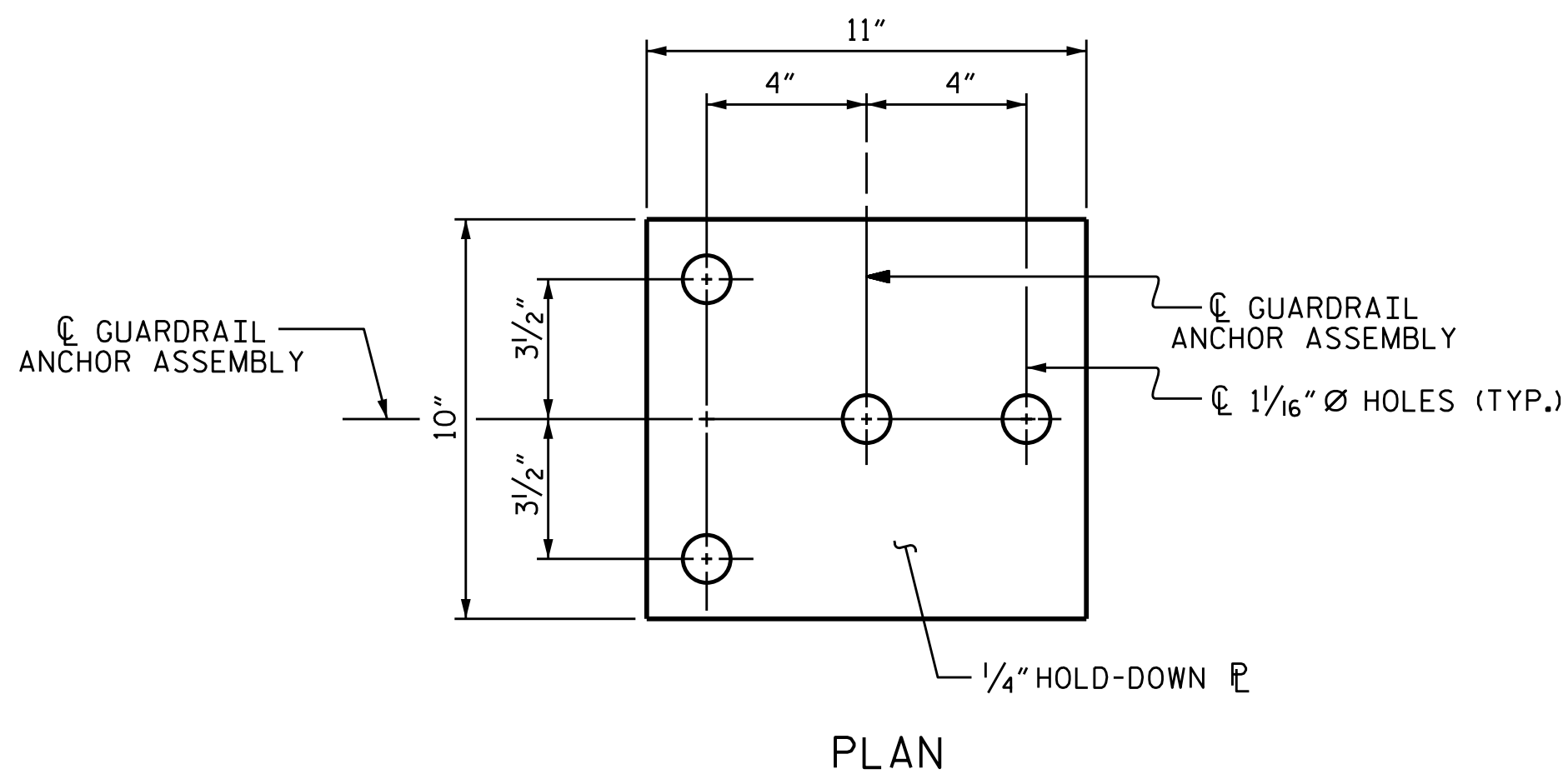

LOCATION OF ANCHORS FOR GUARDRAIL
END BENT 1 SHOWN, END BENT 2 SIMILAR.

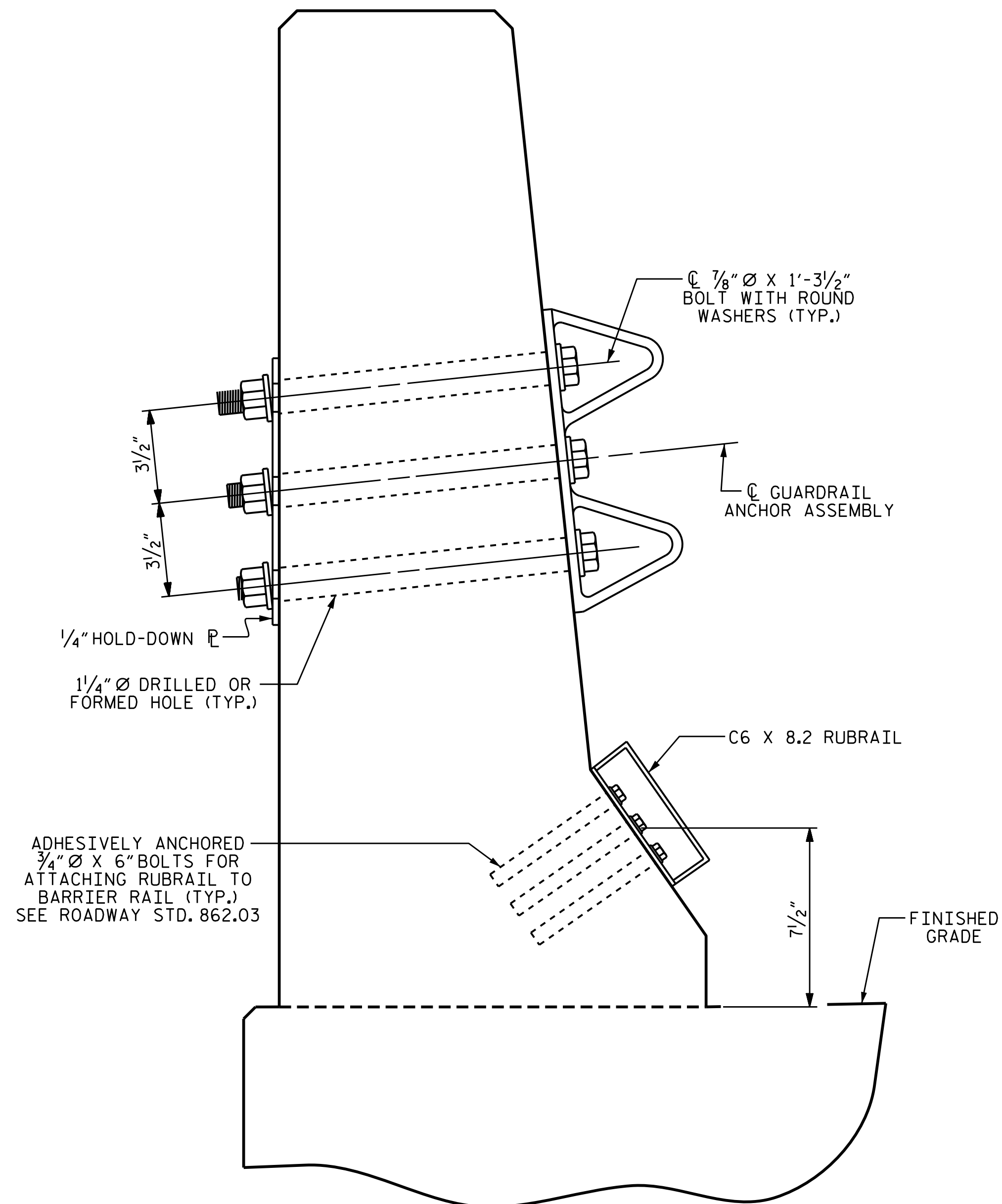

SECTION E-E
GUARDRAIL ANCHOR ASSEMBLY DETAILS

NOTES

THE GUARDRAIL ANCHOR ASSEMBLY SHALL CONSIST OF A 1/4" HOLD-DOWN PLATE AND 4 - 7/8" Ø BOLTS WITH NUTS AND WASHERS, RUBRAIL, AND ADHESIVELY ANCHORED BOLTS.

THE HOLD-DOWN PLATE SHALL CONFORM TO AASHTO M270 GRADE 36. AFTER FABRICATION, THE HOLD-DOWN PLATE SHALL BE HOT-DIP GALVANIZED IN ACCORDANCE WITH AASHTO M111.

BOLTS SHALL CONFORM TO THE REQUIREMENTS OF ASTM A307 AND NUTS SHALL CONFORM TO THE REQUIREMENTS OF AASHTO M291. BOLTS, NUTS AND WASHERS SHALL BE GALVANIZED. (AT THE CONTRACTOR'S OPTION, STAINLESS STEEL BOLTS, NUTS AND WASHERS MAY BE USED AS AN ALTERNATE FOR THE 7/8" Ø GALVANIZED BOLTS, NUTS AND WASHERS. THEY SHALL CONFORM TO OR EXCEED THE MECHANICAL REQUIREMENTS OF ASTM A307. THE USE OF THIS ALTERNATE SHALL BE APPROVED BY THE ENGINEER.)

THE GUARDRAIL ANCHOR ASSEMBLY IS REQUIRED AT ALL POINTS WHERE APPROACH GUARDRAIL IS TO BE ATTACHED TO THE END OF BARRIER RAIL. FOR POINTS OF ATTACHMENT, SEE SKETCH.

AFTER INSTALLATION, THE EXPOSED THREAD OF THE BOLT SHALL BE BURRED WITH A SHARP POINTED TOOL.

THE COST OF THE GUARDRAIL ANCHOR ASSEMBLY SHALL BE INCLUDED IN THE UNIT CONTRACT PRICE BID FOR CONCRETE BARRIER RAIL.

THE 1/4" Ø HOLES SHALL BE FORMED OR DRILLED WITH A CORE BIT. IMPACT TOOLS WILL NOT BE PERMITTED. ANY CONCRETE DAMAGED BY THIS WORK SHALL BE REPAIRED TO THE SATISFACTION OF THE ENGINEER.

THE C6 X 8.2 RUBRAIL IS TO BE ADHESIVELY ANCHORED TO THE RAIL USING THREE 3/4" Ø X 6" BOLTS WITH WASHERS. LEVEL ONE FIELD TESTING IS REQUIRED, AND THE YIELD LOAD OF THE 3/4" Ø BOLT IS 12 KIPS. FOR ADHESIVELY ANCHORED ANCHOR BOLTS OR DOWELS, SEE STANDARD SPECIFICATIONS. SEE ROADWAY STANDARD 862.03 FOR DETAILS AND LOCATION OF THE RUBRAIL.

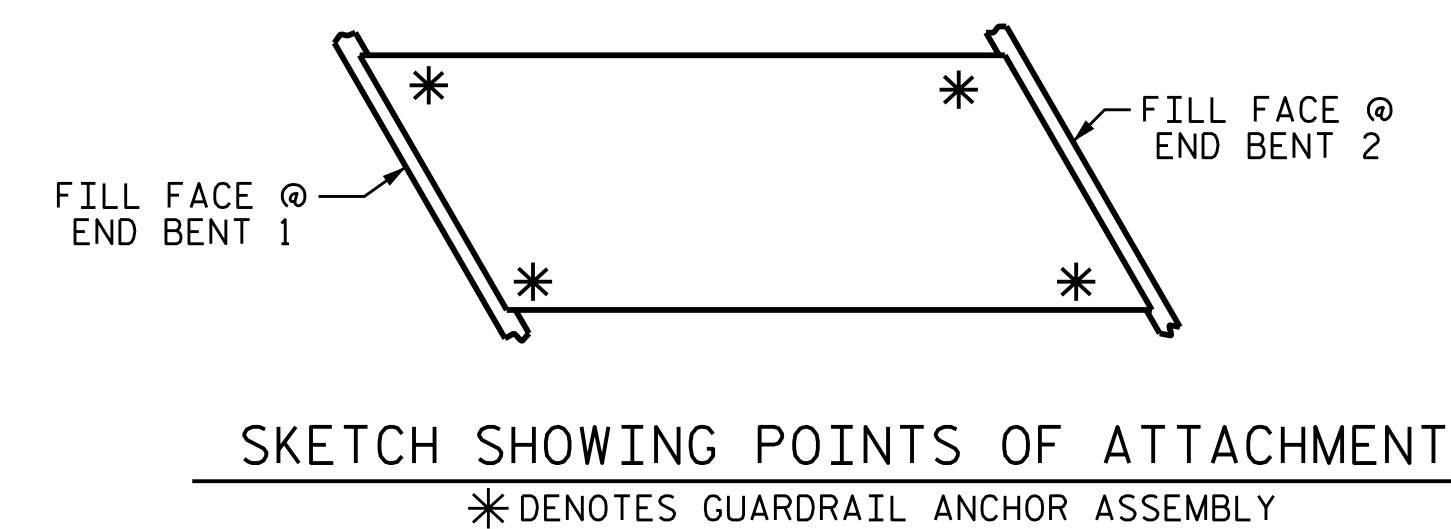

SKETCH SHOWING POINTS OF ATTACHMENTS
* DENOTES GUARDRAIL ANCHOR ASSEMBLY

PROJECT NO. U-2579C
FORSYTH COUNTY
STATION: 473+70.00 -L-

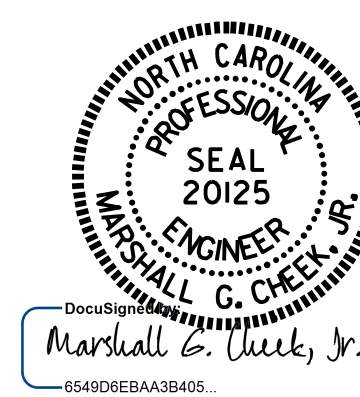

7/27/2017

STATE OF NORTH CAROLINA
DEPARTMENT OF TRANSPORTATION
RALEIGH
STANDARD
GUARDRAIL ANCHORAGE
FOR BARRIER RAIL
(RIGHT LANE)

ASSEMBLED BY :	J. K. BOWLES	DATE :	4/14/16
CHECKED BY :	K. D. LAYNE	DATE :	6/15/16
DRAWN BY :	TLA 5/06	REV. 10/1/11	MAA/GM
CHECKED BY :	GM 5/06	REV. 7/12	MAA/GM
		REV. 6/13	MAA/GM

DOCUMENT NOT CONSIDERED
FINAL UNLESS ALL
SIGNATURES COMPLETED

REVISIONS						TOTAL SHEETS
NO.	BY:	DATE:	NO.	BY:	DATE:	33
1			3			33
2			4			

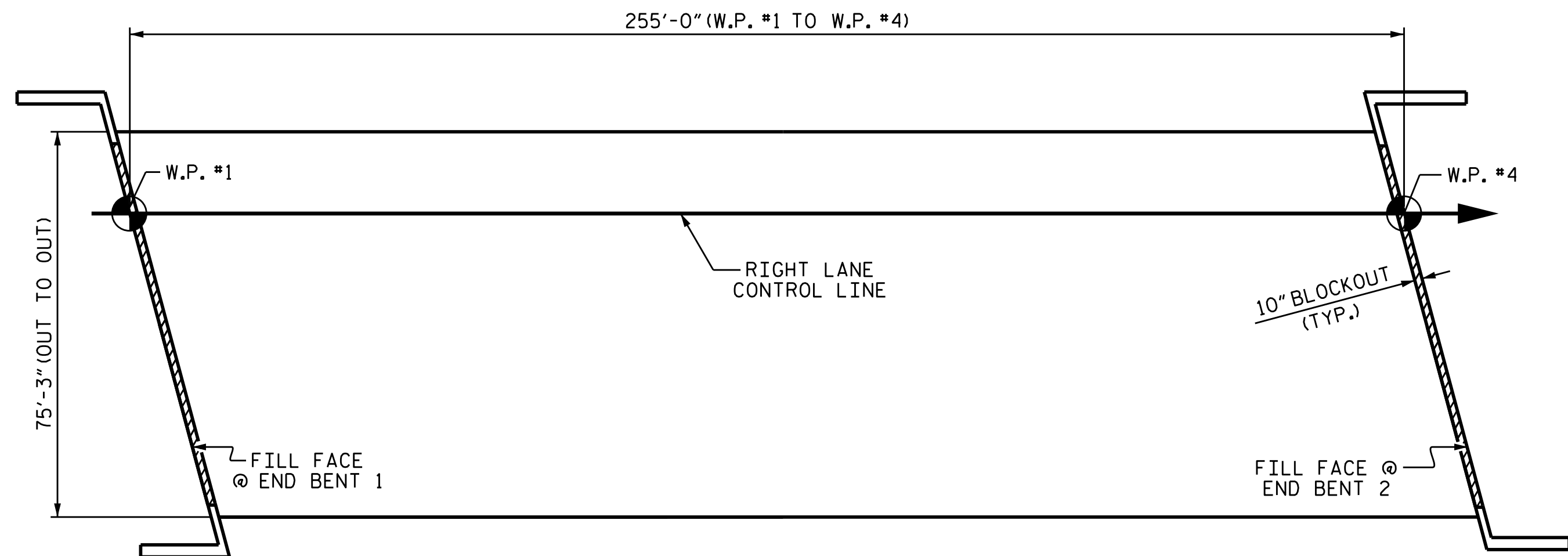

LAYOUT FOR COMPUTING AREA OF REINFORCED CONCRETE DECK SLAB (SQ. FT. 19,189)

BAR TYPE						BILL OF MATERIAL						
BAR	NO.	SIZE	TYPE	LENGTH	WEIGHT	BAR	NO.	SIZE	TYPE	LENGTH	WEIGHT	
*A1	860	#5	STR	38'-9"	34758	*B1	10	#5	STR	52'-7"	548	
A2	860	#5	STR	38'-7"	34608	*B2	197	#5	STR	13'-0"	2671	
*A101	8	#5	STR	37'-1"	309	*B3	100	#4	STR	16'-6"	1102	
*A102	8	#5	STR	35'-1"	293	*B4	99	#5	STR	58'-0"	5989	
*A103	8	#5	STR	33'-1"	276	*B5	98	#5	STR	24'-0"	2453	
*A104	4	#5	STR	59'-5"	248	*B6	100	#4	STR	17'-0"	1136	
*A105	4	#5	STR	55'-5"	231	*B7	198	#5	STR	34'-9"	7176	
*A106	4	#5	STR	51'-4"	214	*B8	98	#5	STR	28'-6"	2913	
*A107	4	#5	STR	47'-4"	197	*B9	100	#4	STR	23'-9"	1587	
*A108	4	#5	STR	43'-3"	180	*B10	197	#5	STR	19'-0"	3904	
*A109	4	#5	STR	39'-3"	164	B11	400	#5	STR	52'-4"	21833	
*A110	4	#5	STR	35'-2"	147	K1	30	#4	STR	26'-5"	529	
*A111	4	#5	STR	31'-2"	130	K2	16	#4	STR	6'-2"	66	
*A112	4	#5	STR	27'-1"	113	K3	96	#4	STR	6'-8"	428	
*A113	4	#5	STR	23'-1"	96	K4	96	#4	STR	7'-9"	497	
*A114	4	#5	STR	19'-0"	79	K5	32	#4	STR	5'-0"	107	
*A115	4	#5	STR	15'-0"	63	K6	20	#4	5	5'-4"	71	
*A116	4	#5	STR	10'-11"	46	K7	70	#4	6	10'-8"	499	
*A117	4	#5	STR	6'-11"	29	K8	4	#4	STR	2'-3"	6	
*A118	4	#5	STR	2'-10"	12	K9	8	#4	STR	2'-6"	13	
						K10	8	#4	STR	3'-0"	16	
A201	8	#5	STR	36'-11"	308							
A202	8	#5	STR	34'-11"	291	S1	416	#4	1	2'-9"	764	
A203	8	#5	STR	32'-11"	275	S2	120	#4	2	11'-5"	915	
A204	4	#5	STR	59'-5"	248	*S3	120	#4	3	11'-11"	955	
A205	4	#5	STR	55'-5"	231	*S4	120	#4	3	11'-1"	888	
A206	4	#5	STR	51'-4"	214							
A207	4	#5	STR	47'-4"	197	U1	80	#4	4	12'-7"	672	
A208	4	#5	STR	43'-3"	180	U2	32	#4	4	10'-7"	226	
A209	4	#5	STR	39'-3"	164	REINFORCING STEEL					LBS.	64,073
A210	4	#5	STR	35'-2"	147	* EPOXY COATED REINFORCING STEEL					LBS.	68,907
A211	4	#5	STR	31'-2"	130							
A212	4	#5	STR	27'-1"	113							
A213	4	#5	STR	23'-1"	96							
A214	4	#5	STR	19'-0"	79							
A215	4	#5	STR	15'-0"	63							
A216	4	#5	STR	10'-11"	46							
A217	4	#5	STR	6'-11"	29							
A218	4	#5	STR	2'-10"	12							

ALL BAR DIMENSIONS ARE OUT TO OUT.

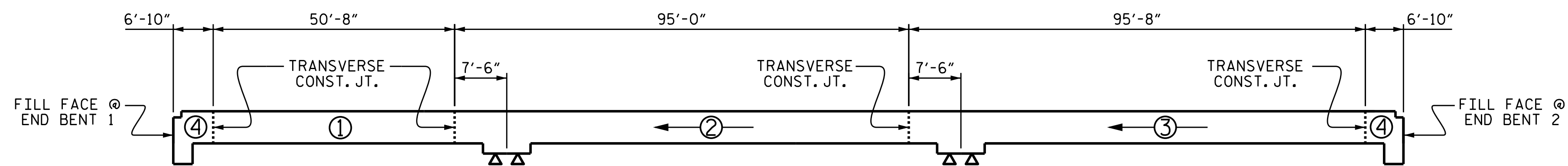

DECK POURING SEQUENCE

⊕ = INDICATES THE NUMBER AND DIRECTION OF POUR.

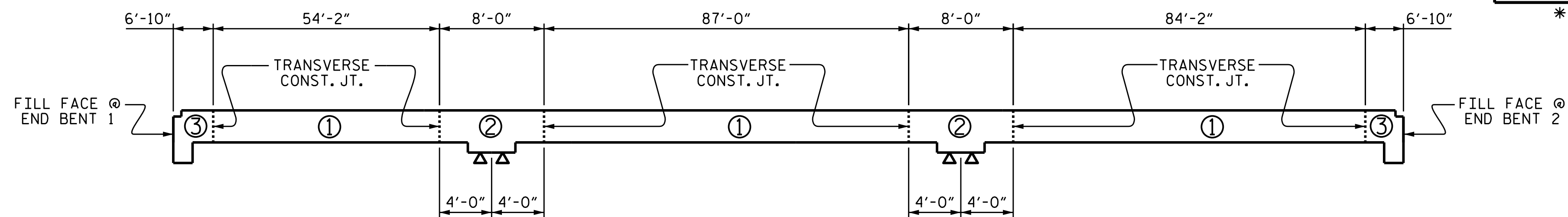

OPTIONAL DECK POURING DETAIL

POURS ② AND ③ SHALL NOT BE STARTED UNTIL BOTH ADJACENT POUR ① REACH A MINIMUM OF 3000 PSI

GROOVING BRIDGE FLOORS

APPROACH SLABS	3,331	SO. FT.
BRIDGE DECK	17,452	SO. FT.
TOTAL	20,783	SO. FT.

SUPERSTRUCTURE BILL OF MATERIAL

	CLASS AA CONCRETE (C.Y.)	REINFORCING STEEL (LBS.)	EPOXY COATED REINFORCING STEEL (LBS.)
POUR #1	118.1		
POUR #2	248.3		
POUR #3	249.5	64,073	68,907
POUR #4	107.1		
TOTAL **	723.0	64,073	68,907

** QUANTITIES FOR CONCRETE BARRIER RAIL ARE NOT INCLUDED

SUPERSTRUCTURE REINFORCING STEEL LENGTHS ARE BASED ON THE FOLLOWING MINIMUM SPLICE LENGTHS

BAR SIZE	SUPERSTRUCTURE EXCEPT APPROACH SLABS, PARAPET, AND BARRIER RAIL		APPROACH SLABS		PARAPET AND BARRIER RAIL
	EPOXY COATED	UNCOATED	EPOXY COATED	UNCOATED	
#4	2'-0"	1'-9"	2'-0"	1'-9"	2'-9"
#5	2'-6"	2'-2"	2'-6"	2'-2"	3'-5"
#6	3'-0"	2'-7"	3'-10"	2'-7"	4'-4"
#7	5'-3"	3'-6"			
#8	6'-10"	4'-7"			

PROJECT NO. U-2579C
 FORSYTH COUNTY
 STATION: 473+70.00 -L-

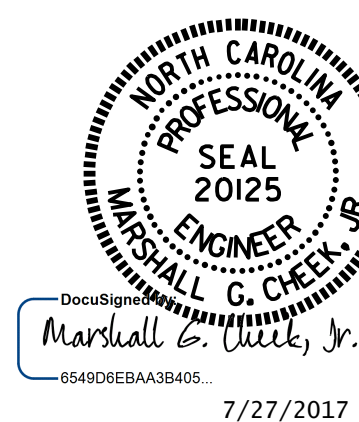

STATE OF NORTH CAROLINA
 DEPARTMENT OF TRANSPORTATION
 RALEIGH
 SUPERSTRUCTURE
 BILL OF MATERIAL
 (RIGHT LANE)

DRAWN BY: J. K. BOWLES DATE: 4/14/16
 CHECKED BY: K. D. LAYNE DATE: 6/15/16
 DESIGN ENGINEER OF RECORD: H. A. LOCKLEAR DATE: 6/20/17

DOCUMENT NOT CONSIDERED FINAL UNLESS ALL SIGNATURES COMPLETED

REVISIONS				SHEET NO. S4-20
NO.	BY:	DATE:	DESCRIPTION	
1			3	TOTAL SHEETS 33
2			4	

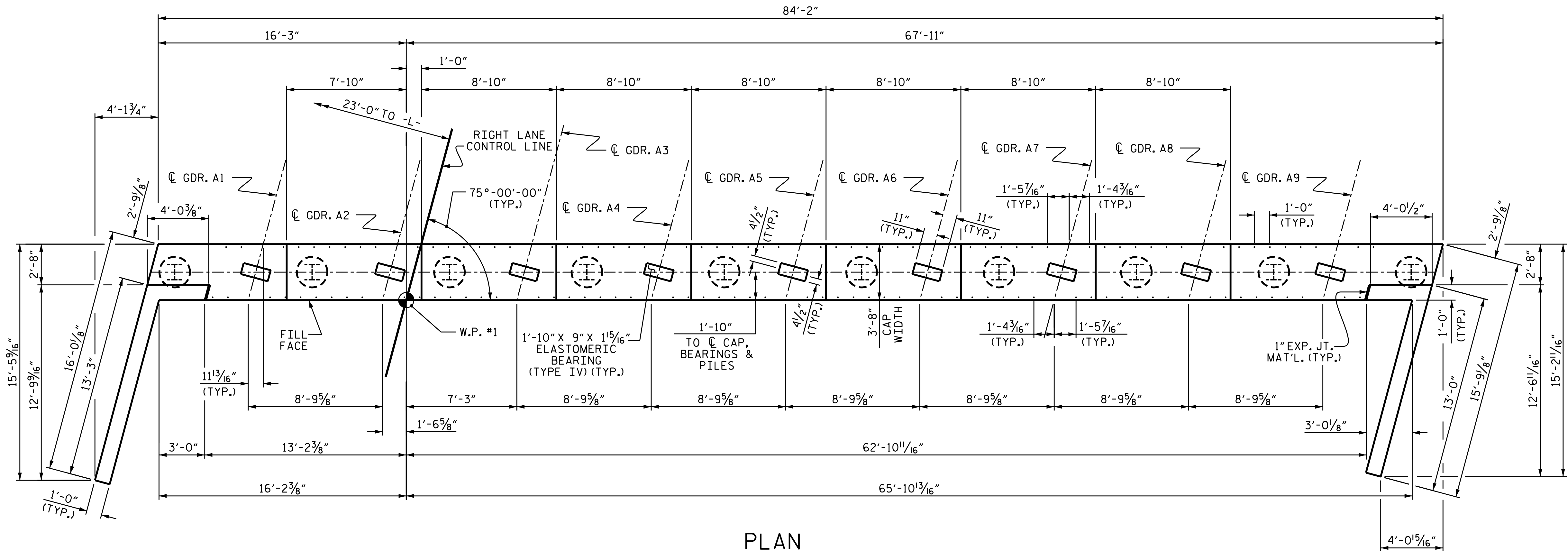

NOTES
 THE TOP SURFACE OF THE END BENT CAP, EXCEPT THE BEARING AREA, SHALL BE RAKED TO A DEPTH OF 1/4".

TOP OF PILE ELEVATIONS	
①	877.96
②	877.75
③	877.55
④	877.34
⑤	877.14
⑥	876.93
⑦	876.72
⑧	876.52
⑨	876.31
⑩	876.11

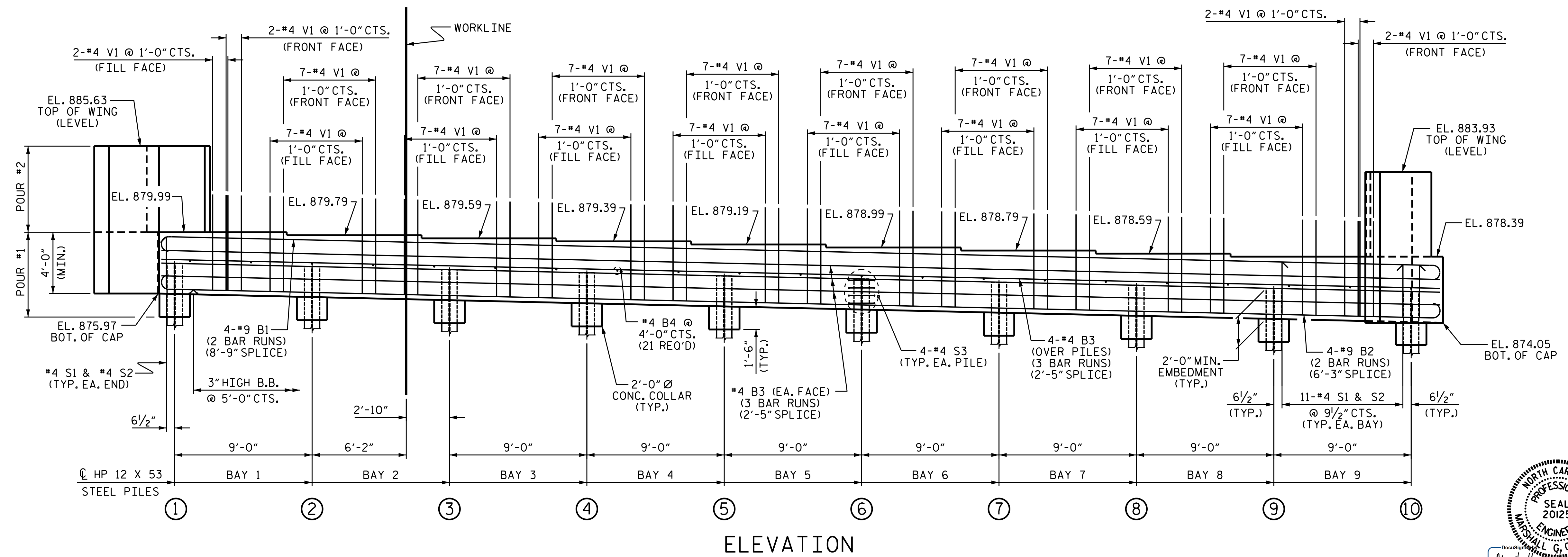

PROJECT NO. U-2579C
 FORSYTH COUNTY
 STATION: 473+70.00 -L-
 SHEET 1 OF 3

STATE OF NORTH CAROLINA
 DEPARTMENT OF TRANSPORTATION
 RALEIGH
 SUBSTRUCTURE
 INTEGRAL
 END BENT 1
 (RIGHT LANE)

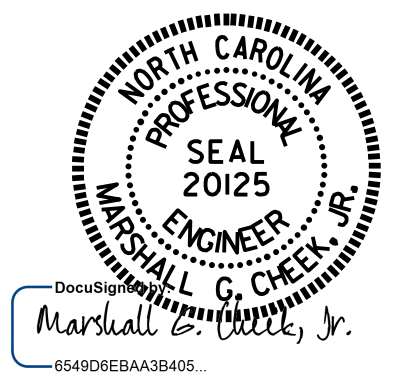

DRAWN BY: H.A. LOCKLEAR DATE: 6/29/16
 CHECKED BY: K.D. LAYNE DATE: 8/3/16
 DESIGN ENGINEER OF RECORD: H.A. LOCKLEAR DATE: 8/18/16

DOCUMENT NOT CONSIDERED FINAL UNLESS ALL SIGNATURES COMPLETED

REVISIONS						SHEET NO.
NO.	BY:	DATE:	NO.	BY:	DATE:	S4-21
1			3			TOTAL SHEETS
2			4			33

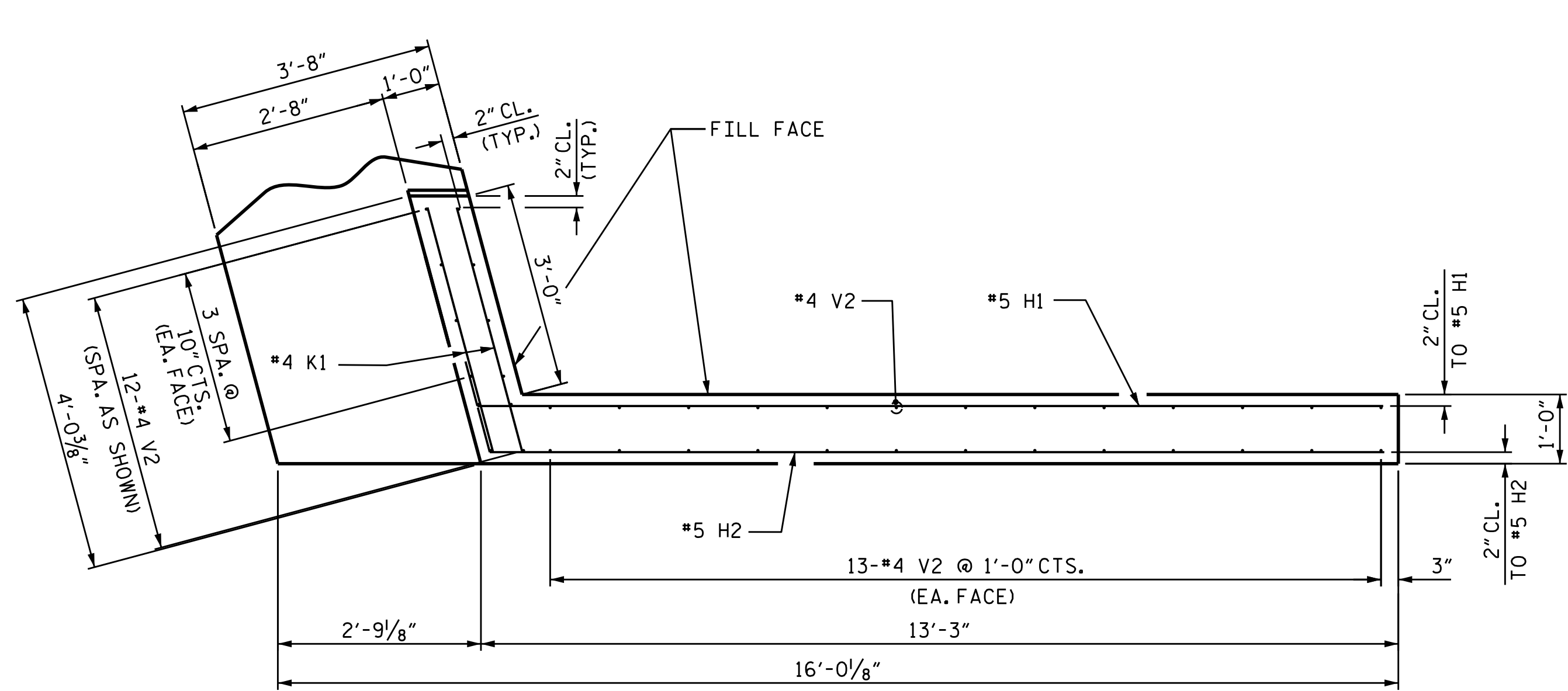

PLAN OF LEFT WING

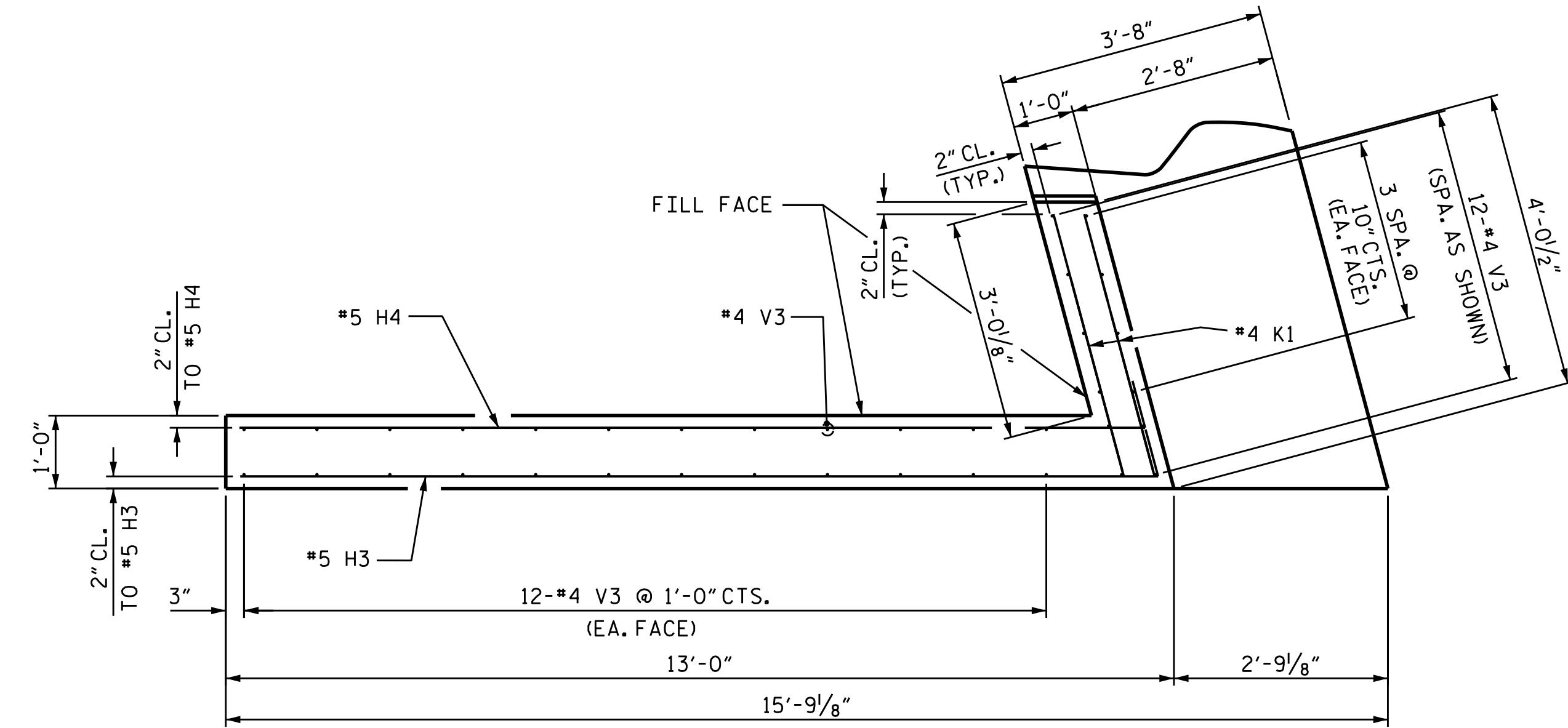

PLAN OF RIGHT WING

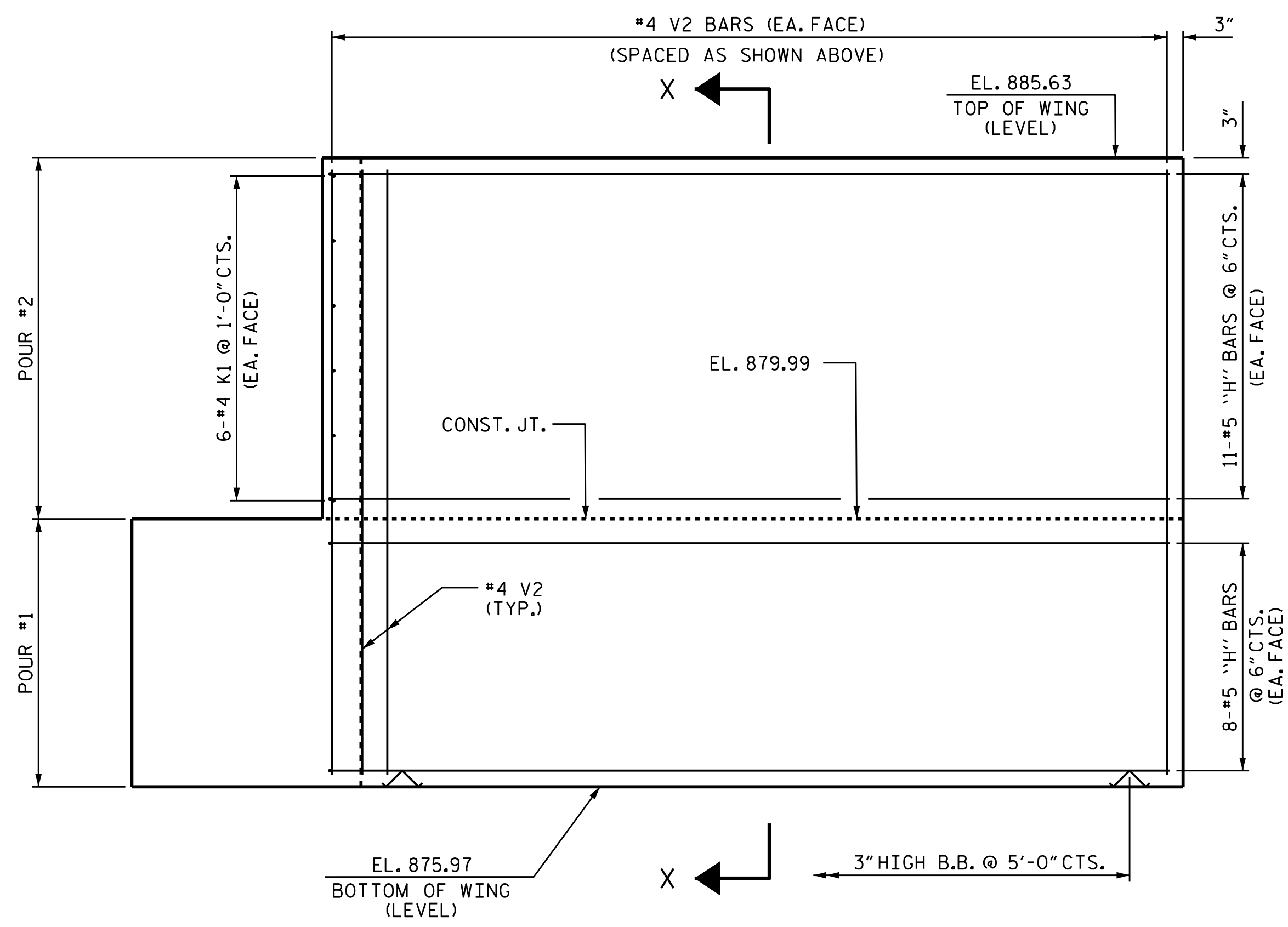

ELEVATION OF LEFT WING

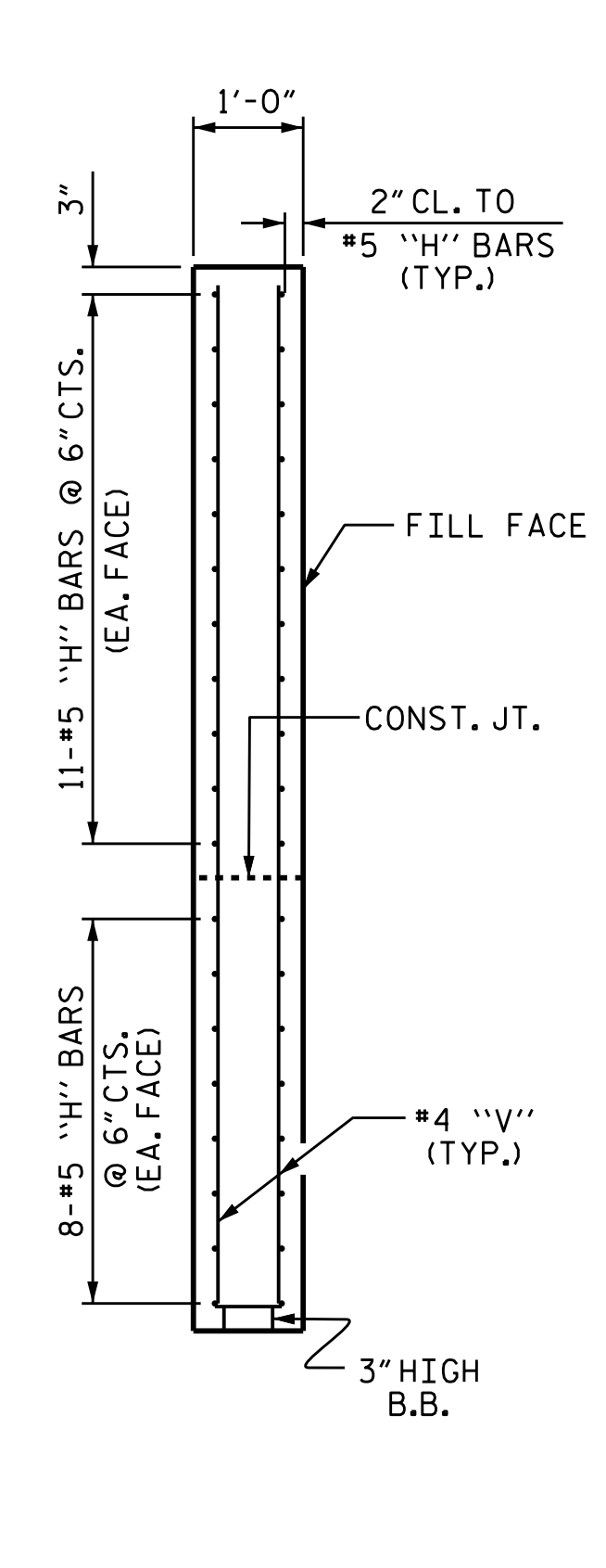

SECTION X-X

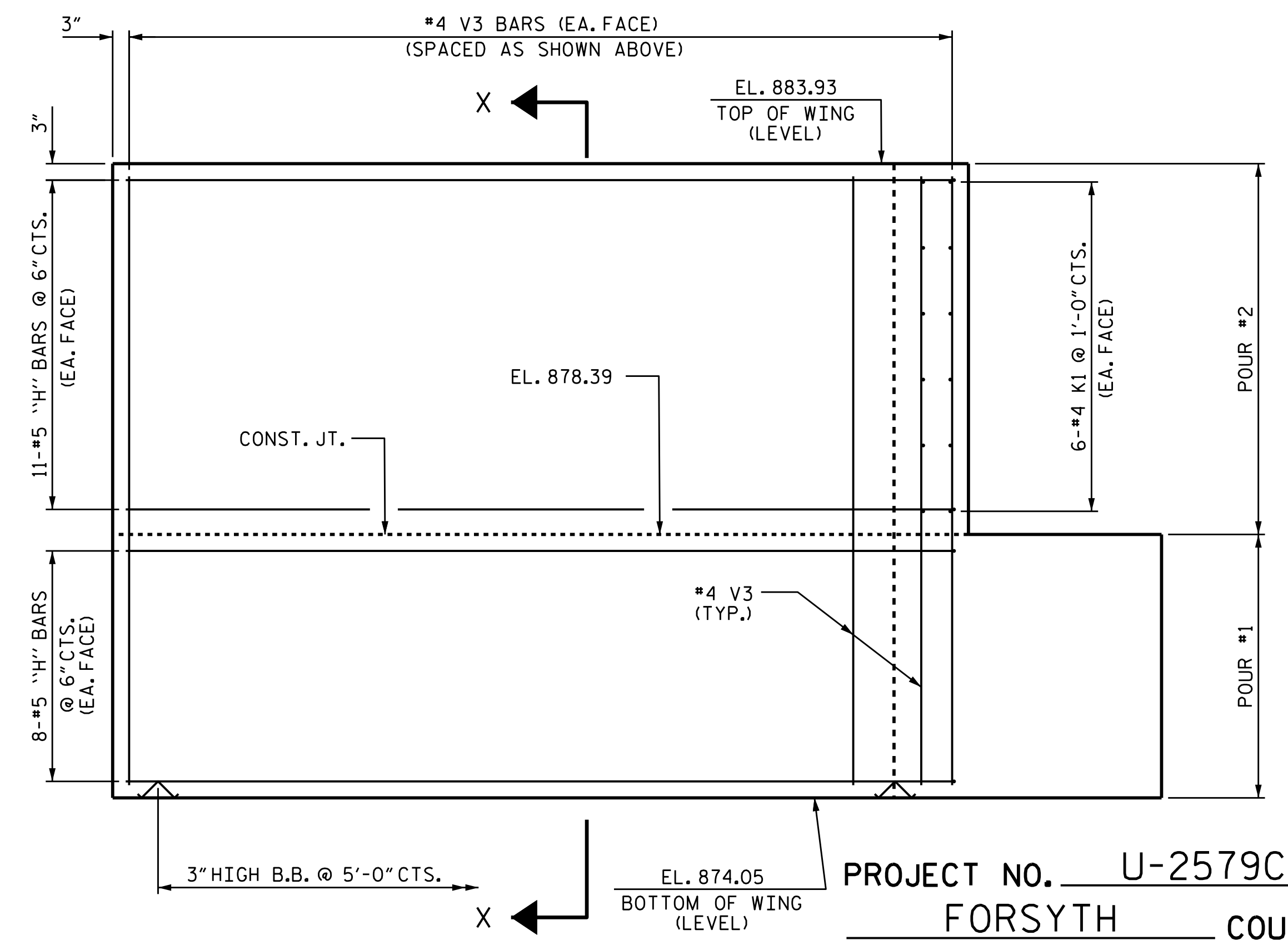

ELEVATION OF RIGHT WING

PROJECT NO. U-2579C
 FORSYTH COUNTY
 STATION: 473+70.00 -L-

SHEET 2 OF 3
 STATE OF NORTH CAROLINA
 DEPARTMENT OF TRANSPORTATION
 RALEIGH
 SUBSTRUCTURE
 INTEGRAL
 END BENT 1
 (RIGHT LANE)

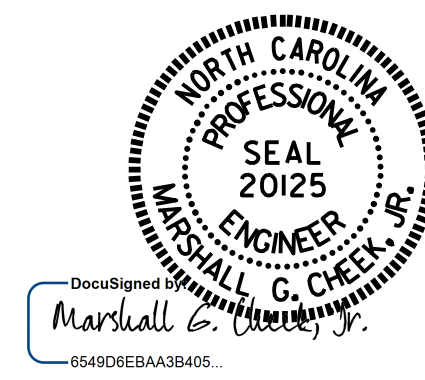

DRAWN BY : H.A. LOCKLEAR DATE : 6/29/16
 CHECKED BY : K.D. LAYNE DATE : 8/3/16
 DESIGN ENGINEER OF RECORD : H.A. LOCKLEAR DATE : 8/18/16

DOCUMENT NOT CONSIDERED
 FINAL UNLESS ALL
 SIGNATURES COMPLETED

REVISIONS						SHEET NO.
NO.	BY:	DATE:	NO.	BY:	DATE:	S4-22
1			3			TOTAL SHEETS
2			4			33

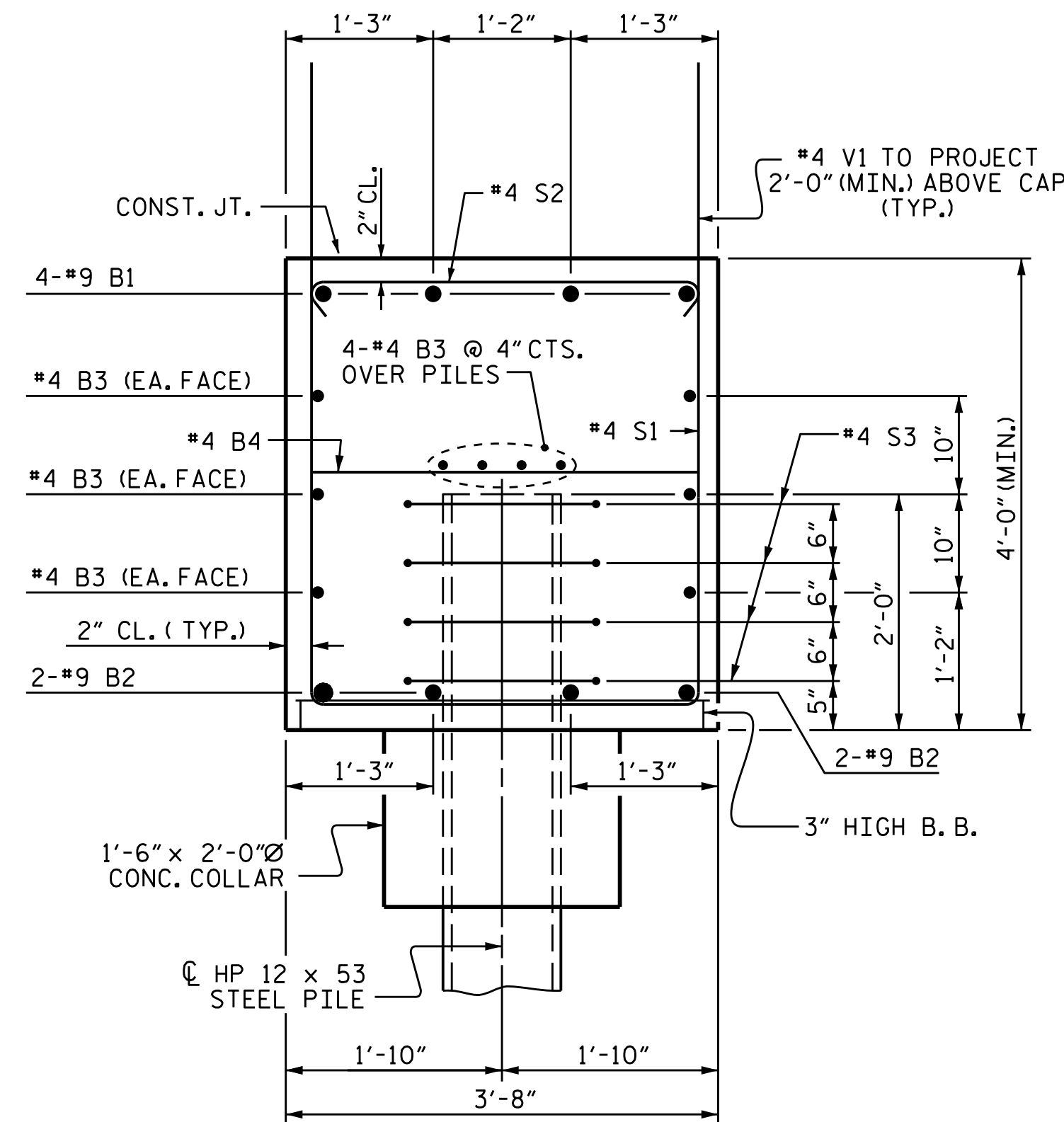

SECTION THRU CAP

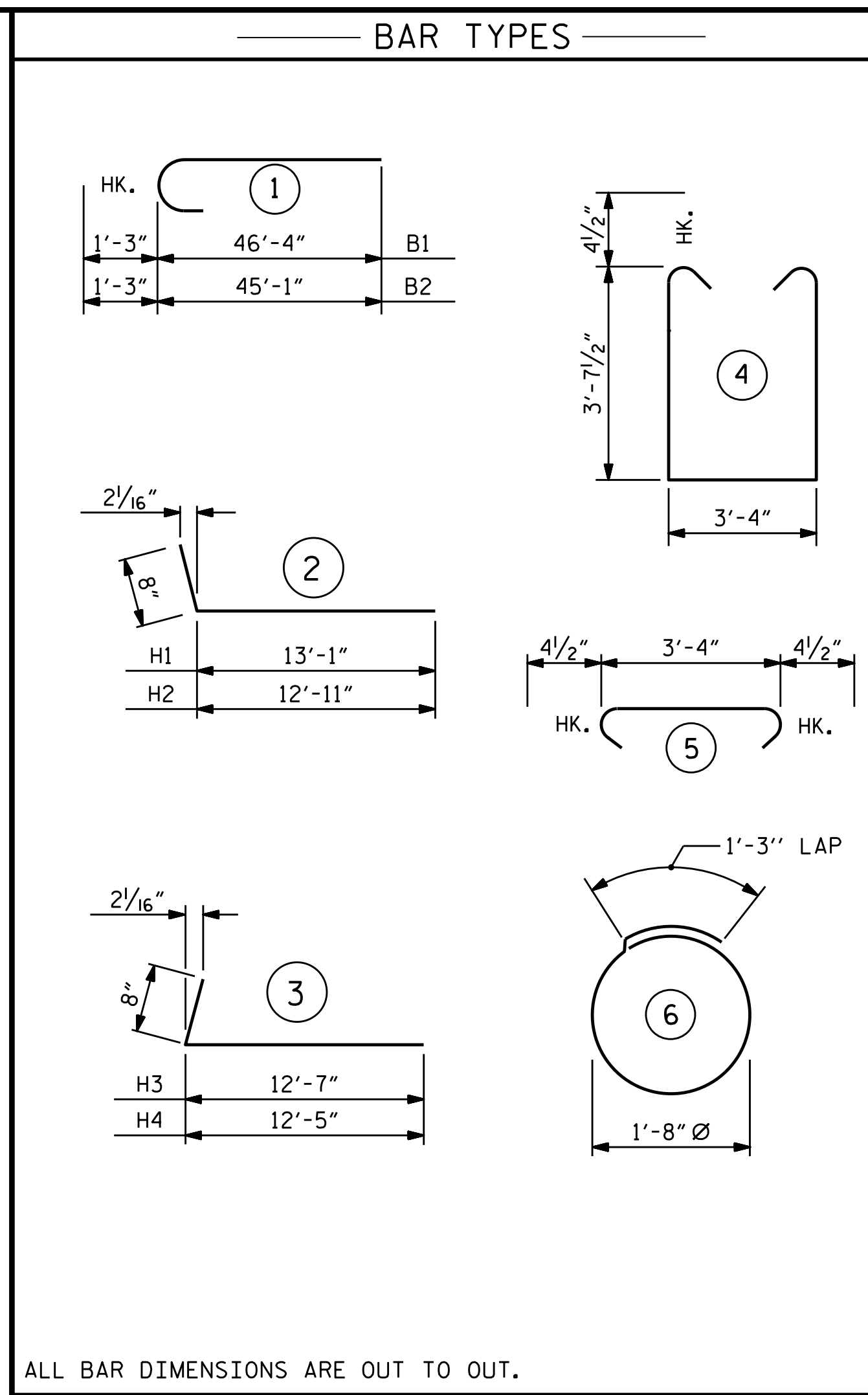

ALL BAR DIMENSIONS ARE OUT TO OUT.

BILL OF MATERIAL					
INTEGRAL END BENT 1					
BAR NO.	SIZE	TYPE	LENGTH	WEIGHT	
B1	#9	1	47'-7"	1294	
B2	#9	1	46'-4"	1260	
B3	#4	STR	29'-7"	593	
B4	#4	STR	3'-4"	47	
H1	#5	2	13'-9"	272	
H2	#5	2	13'-7"	269	
H3	#5	3	13'-3"	263	
H4	#5	3	13'-1"	259	
K1	#4	STR	3'-8"	59	
S1	#4	4	11'-4"	765	
S2	#4	5	4'-1"	275	
S3	#4	6	6'-6"	174	
V1	#4	STR	6'-0"	481	
V2	#4	STR	9'-3"	235	
V3	#4	STR	9'-6"	228	
REINFORCING STEEL				LBS.	6,474
CLASS A CONCRETE					
POUR #1 CAP, LOWER WINGS & CONC. COLLARS				C.Y.	52.7
POUR #2 UPPER PART OF WINGS				C.Y.	6.7
TOTAL CLASS A CONCRETE				C.Y.	59.4
HP 12 X 53 STEEL PILES					
NO.: 10			LIN. FT.	650	
PILE DRIVING EQUIPMENT SETUP FOR HP 12 X 53 STEEL PILES					
				EACH	10

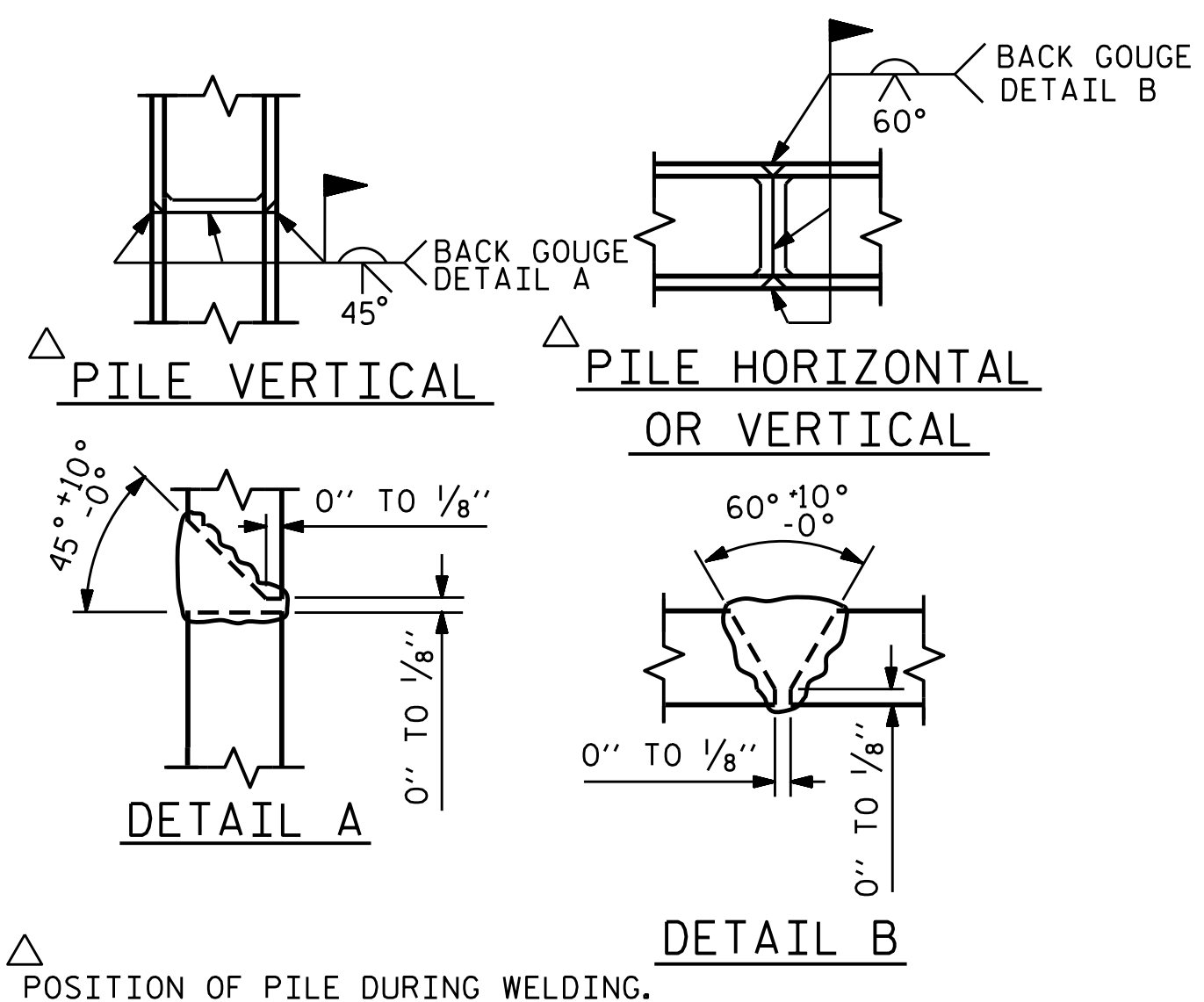

PILE SPLICE DETAILS

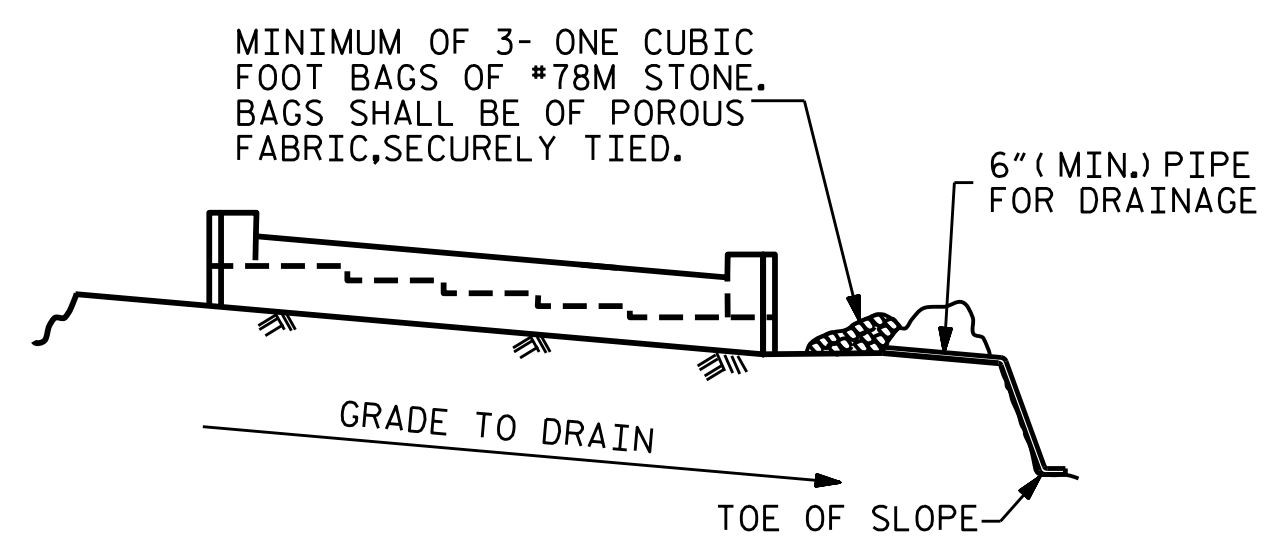

MINIMUM OF 3- ONE CUBIC FOOT BAGS OF #78M STONE. BAGS SHALL BE OF POROUS FABRIC, SECURELY TIED.

BAGGED STONE AND PIPE SHALL BE PLACED IMMEDIATELY AFTER COMPLETION OF END BENT EXCAVATION. PIPE MAY BE EITHER CONCRETE, CORRUGATED STEEL, CORRUGATED ALUMINUM ALLOY, OR CORRUGATED PLASTIC. PERFORATED PIPE WILL NOT BE ALLOWED.

BAGGED STONE SHALL REMAIN IN PLACE UNTIL THE ENGINEER DIRECTS THAT IT BE REMOVED. THE CONTRACTOR SHALL REMOVE AND DISPOSE OF SILT ACCUMULATIONS AT BAGGED STONE WHEN SO DIRECTED BY THE ENGINEER. BAGS SHALL BE REMOVED AND REPLACED WHENEVER THE ENGINEER DETERMINES THAT THEY HAVE DETERIORATED AND LOST THEIR EFFECTIVENESS.

NO SEPARATE PAYMENT WILL BE MADE FOR THIS WORK AND THE ENTIRE COST OF THIS WORK SHALL BE INCLUDED IN THE UNIT CONTRACT PRICE BID FOR THE SEVERAL PAY ITEMS.

TEMPORARY DRAINAGE AT END BENT

PROJECT NO. U-2579C
FORSYTH COUNTY
 STATION: 473+70.00 -L-

SHEET 3 OF 3

STATE OF NORTH CAROLINA
 DEPARTMENT OF TRANSPORTATION
 RALEIGH
 SUBSTRUCTURE
 INTEGRAL
 END BENT 1
 (RIGHT LANE)

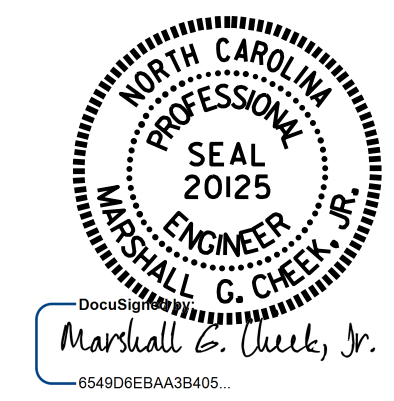

7/27/2017

DRAWN BY : H.A. LOCKLEAR DATE : 6/23/16
 CHECKED BY : K.D. LAYNE DATE : 8/3/16
 DESIGN ENGINEER OF RECORD: H.A. LOCKLEAR DATE : 8/18/16

DOCUMENT NOT CONSIDERED FINAL UNLESS ALL SIGNATURES COMPLETED

REVISIONS						SHEET NO.	
NO.	BY:	DATE:	NO.	BY:	DATE:	S4-23	
1			3			TOTAL SHEETS	33
2			4				

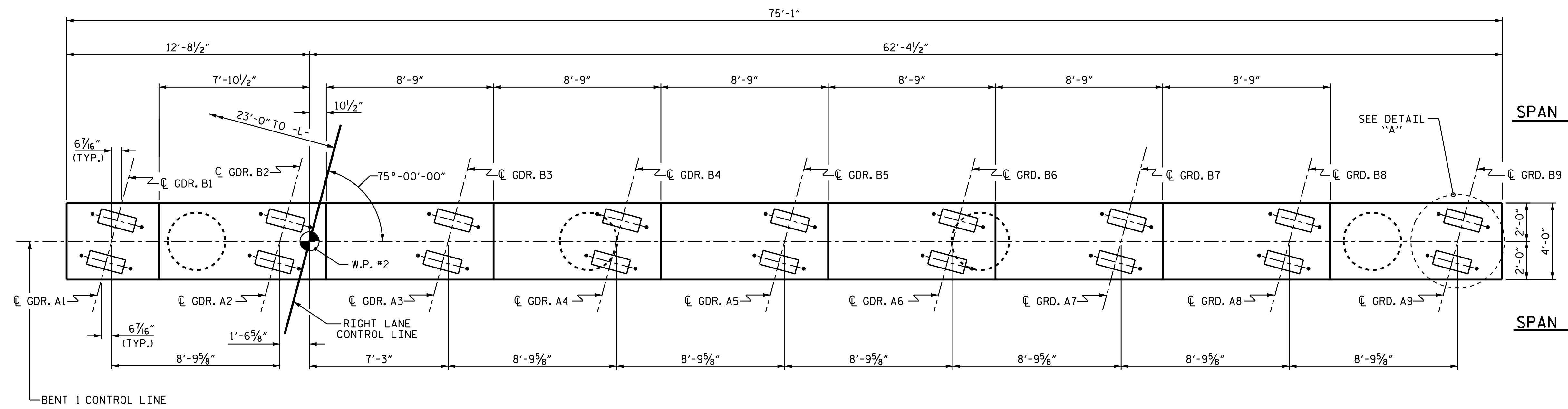

PLAN

NOTES

ALL STEEL IN THE DRILLED PIERS IS INCLUDED IN THE PAY ITEMS FOR "REINFORCING STEEL" AND "SPIRAL COLUMN REINFORCING."

THE CONTRACTOR'S ATTENTION IS CALLED TO THE FACT THAT THE LONGITUDINAL REINFORCEMENT FOR THE DRILLED PIERS IS DETAILED WITH 3 FEET OF EXTRA LENGTH.

THE LOCATION OF THE CONSTRUCTION JOINT IN THE DRILLED PIERS IS BASED ON AN APPROXIMATE GROUND LINE ELEVATION. IF THE CONSTRUCTION JOINT IS ABOVE THE ACTUAL GROUND LINE ELEVATION, THE CONTRACTOR SHALL PLACE THE CONSTRUCTION JOINT 1 FT. BELOW THE GROUND LINE.

STIRRUPS IN CAP MAY BE SHIFTED AS NECESSARY TO CLEAR ANCHOR BOLTS.

HOOKS ON "V" BARS MAY BE TURNED AS NECESSARY FOR PLACING REINFORCING STEEL.

SPAN B

SPAN A

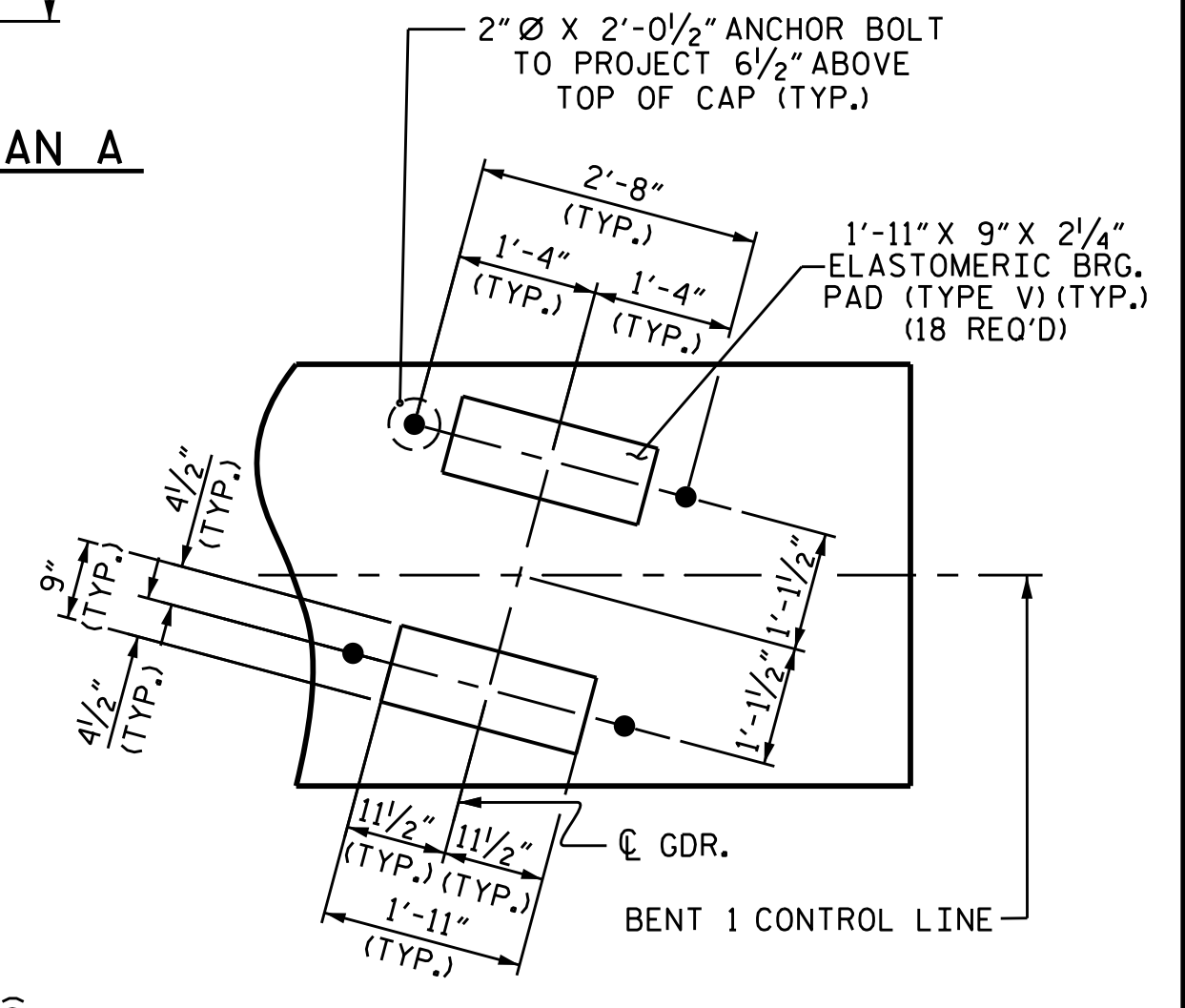

DETAIL "A"
TYP. EA. GDR.

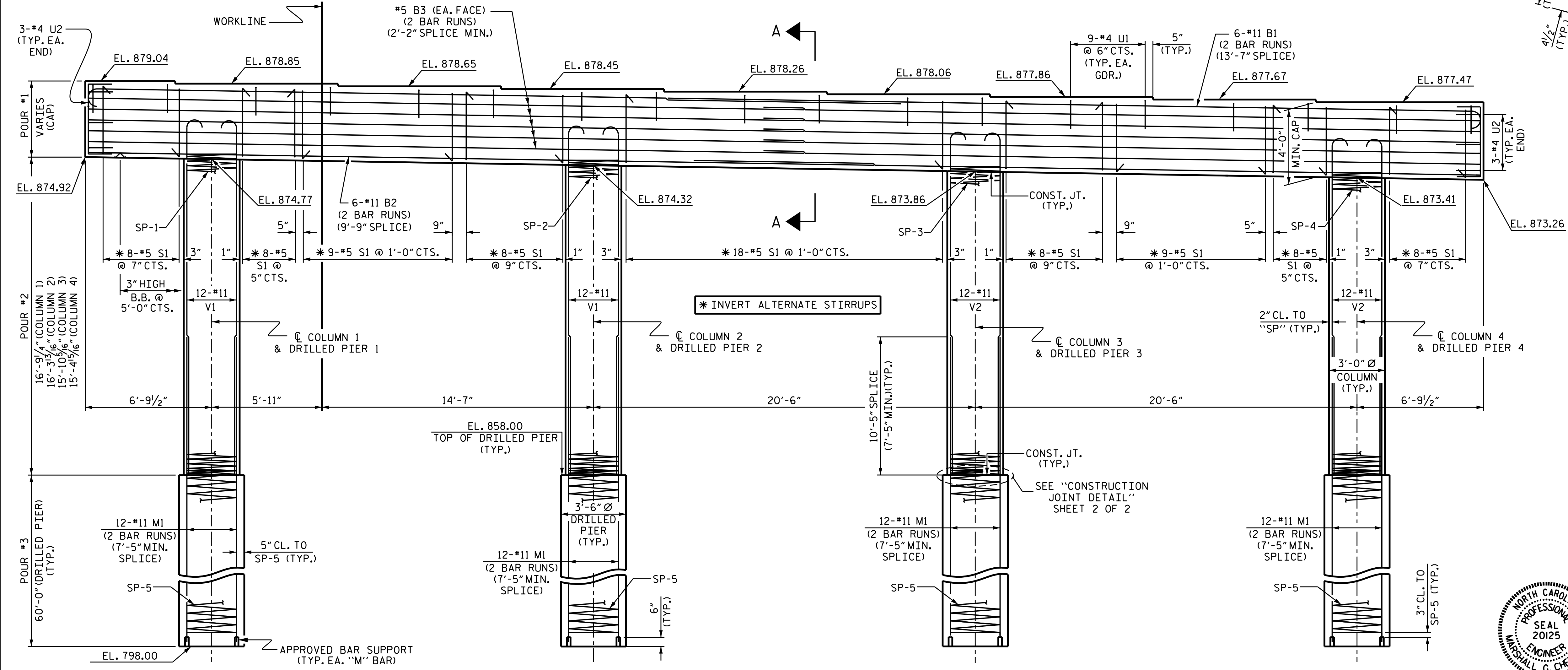

ELEVATION

PROJECT NO. U-2579C
FORSYTH COUNTY
 STATION: 473+70.00 -L-

SHEET 1 OF 2



7/27/2017

STATE OF NORTH CAROLINA
 DEPARTMENT OF TRANSPORTATION
 RALEIGH
 SUBSTRUCTURE
 BENT 1
 (RIGHT LANE)

DRAWN BY: ARIADNE L. PALMA P. DATE: 8-29-16
 CHECKED BY: M.K. BEARD DATE: 9-8-16
 DESIGN ENGINEER OF RECORD: H.A. LOCKLEAR DATE: 6/2017

DOCUMENT NOT CONSIDERED
 FINAL UNLESS ALL
 SIGNATURES COMPLETED

REVISIONS						SHEET NO.
NO.	BY:	DATE:	NO.	BY:	DATE:	S4-24
1			3			TOTAL SHEETS
2			4			33

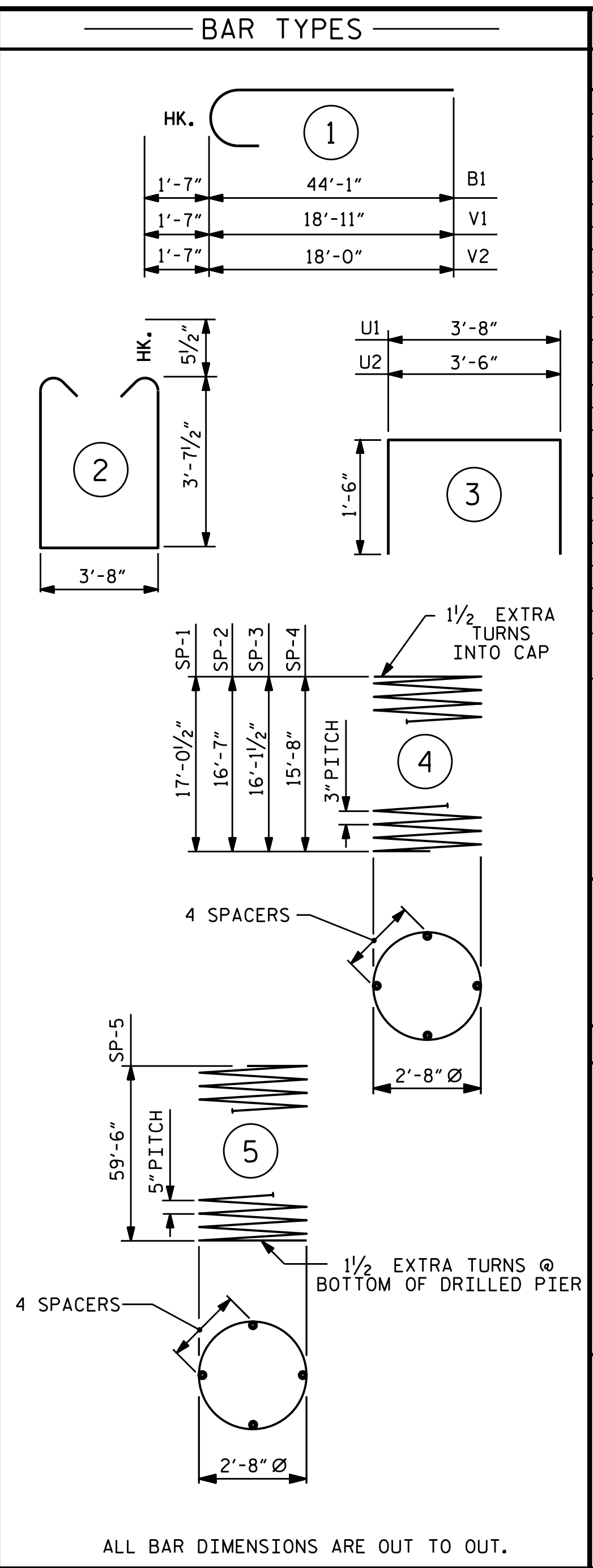
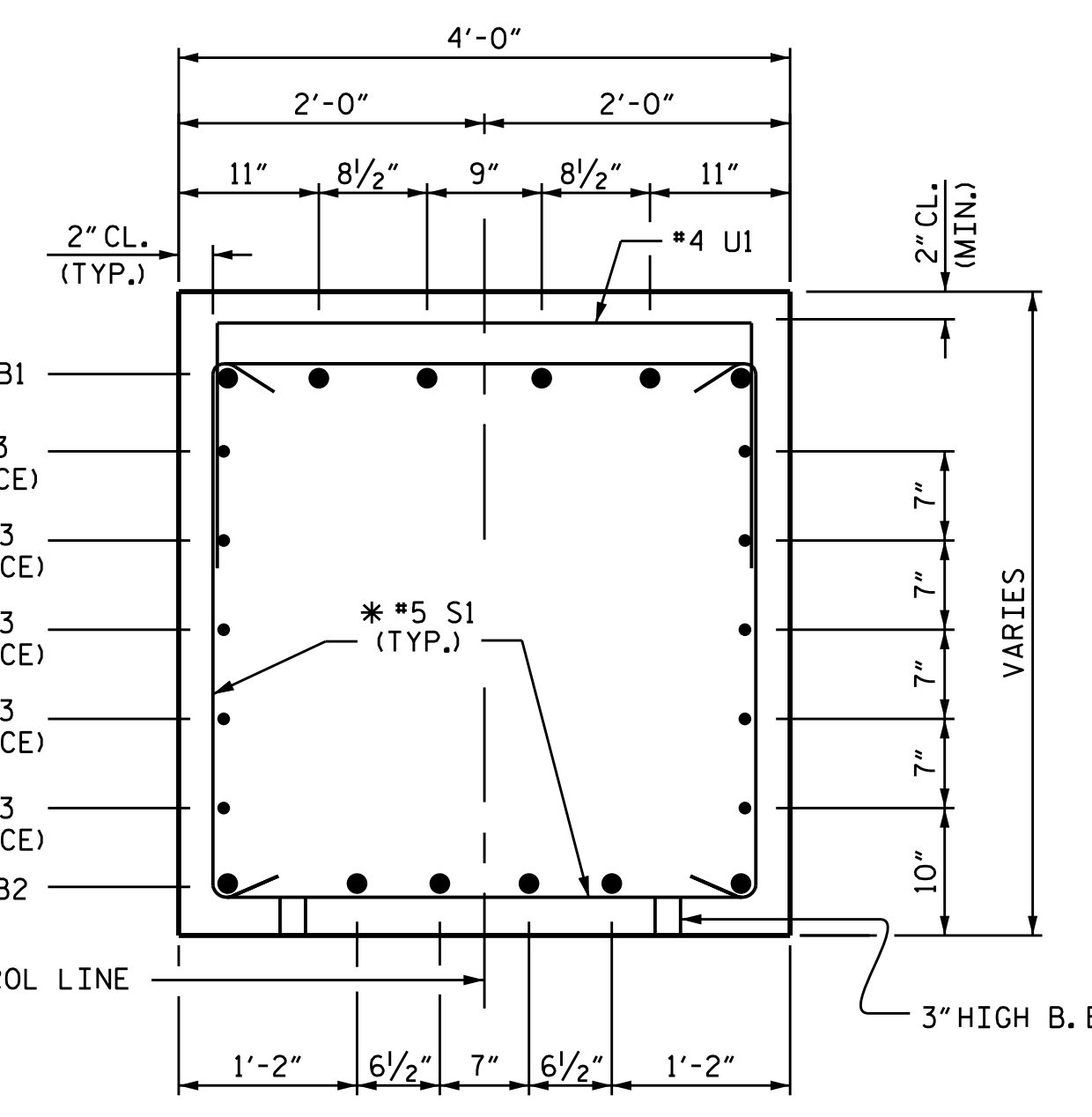
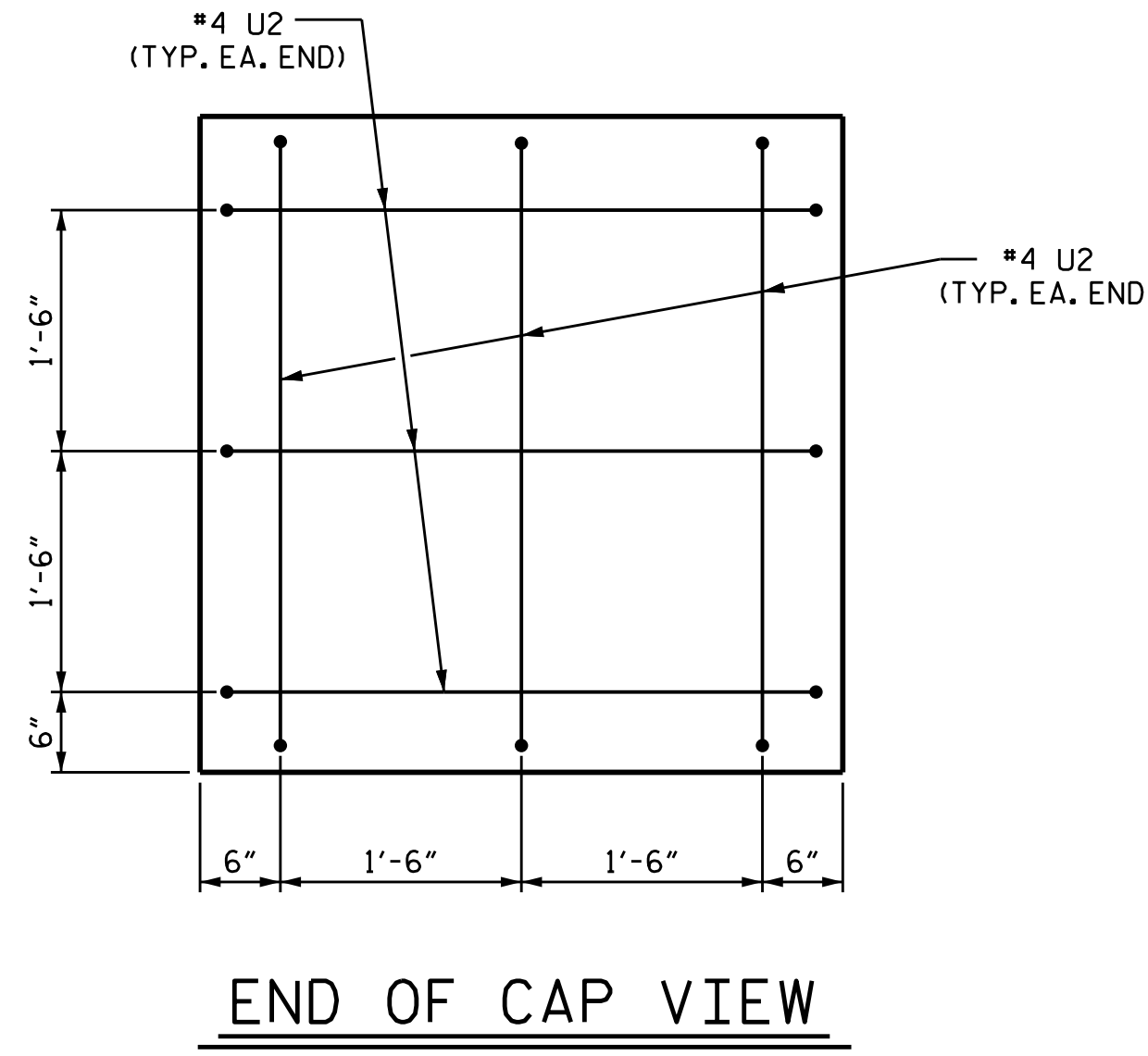
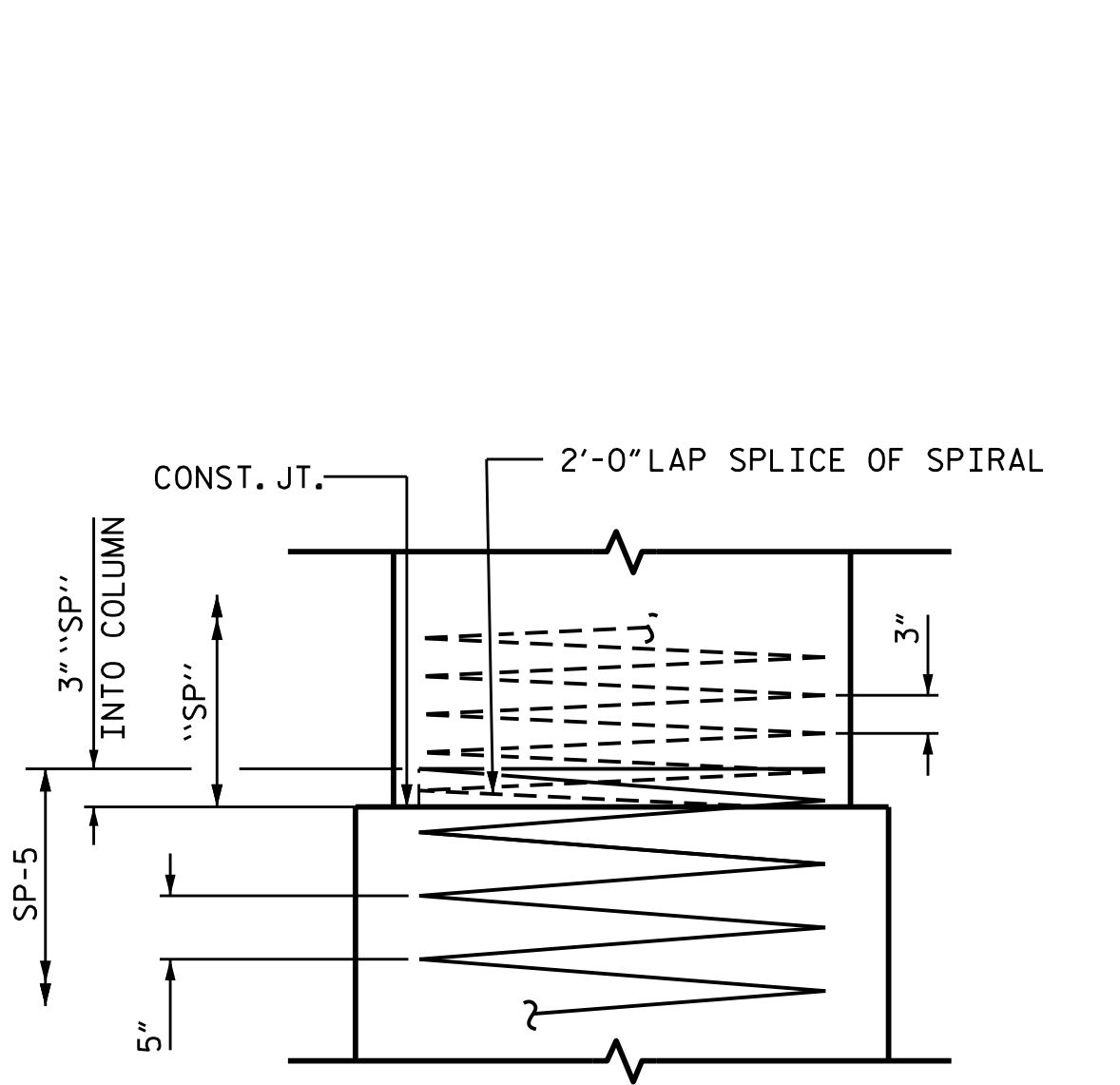
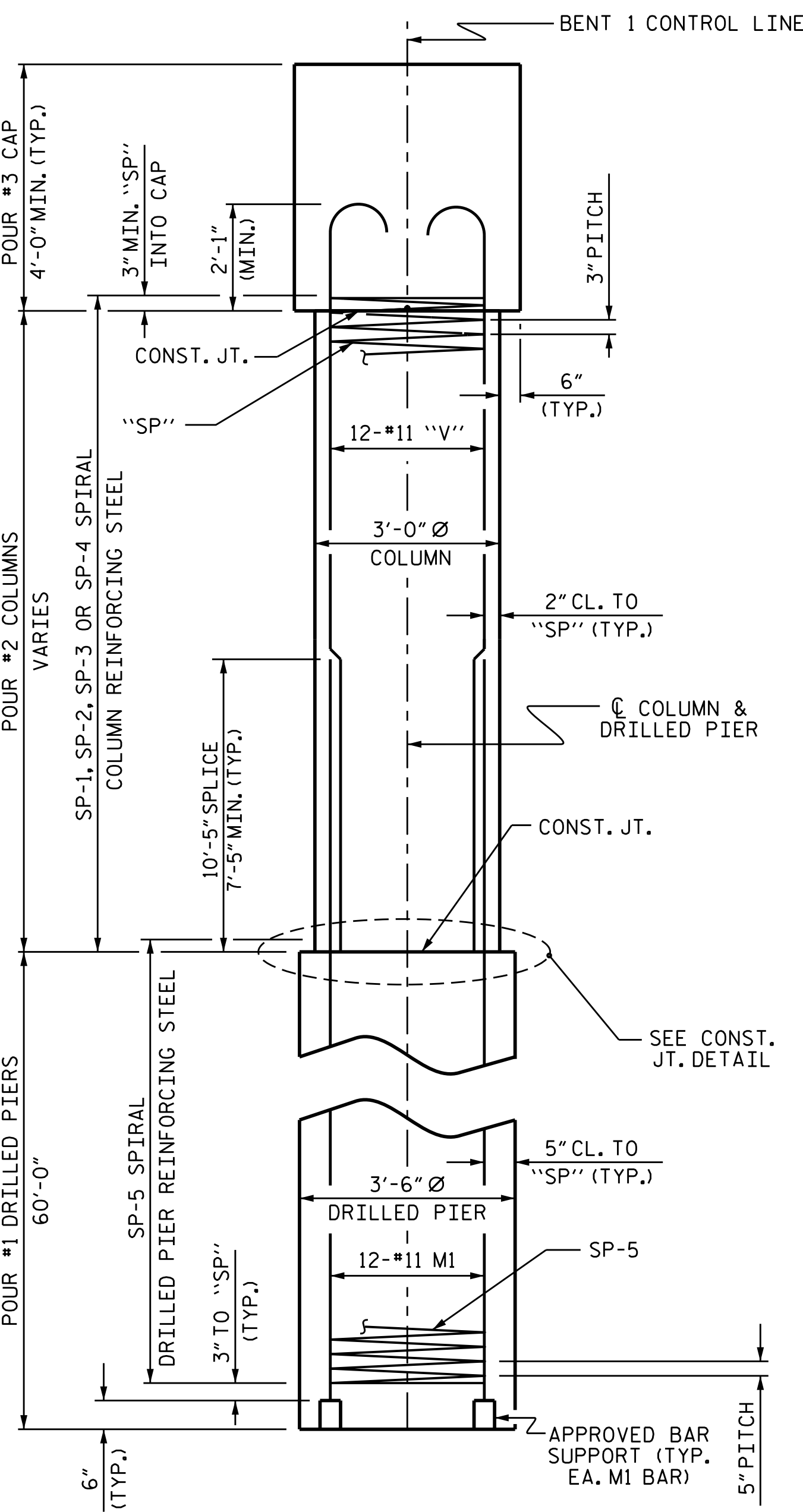
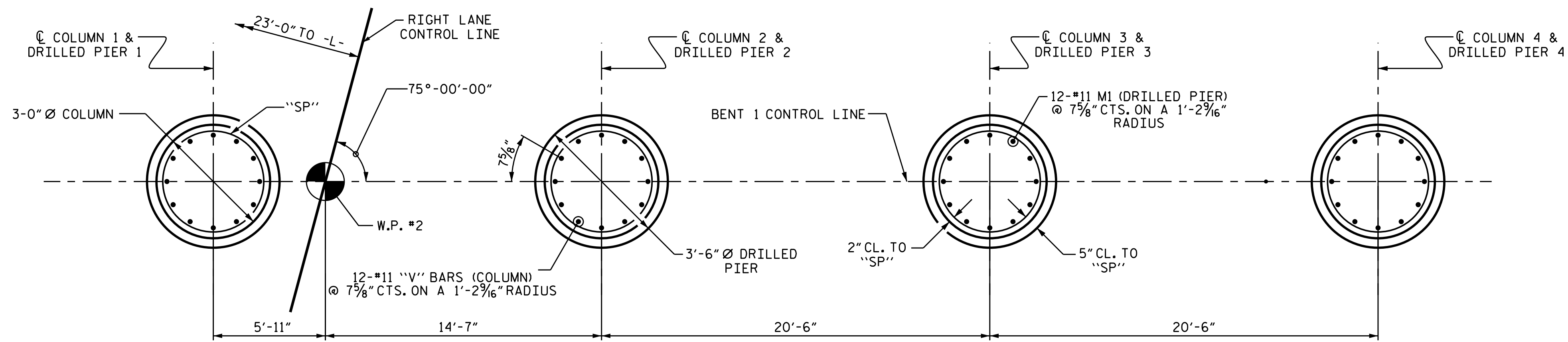

BILL OF MATERIAL					
BENT 1					
BAR NO.	SIZE	TYPE	LENGTH	WEIGHT	
B1	12	#11	45'-8"	2912	
B2	12	#11	STR 42'-3"	2694	
B3	20	#5	STR 38'-6"	803	
M1	96	#11	STR 38'-10"	19807	
S1	84	#5	2 11'-10"	1037	
U1	81	#4	3 6'-8"	361	
U2	12	#4	3 6'-6"	52	
V1	24	#11	1 20'-6"	2614	
V2	24	#11	1 19'-7"	2497	
REINFORCING STEEL				LBS.	32,777
SP-1	1	*	4 575'-6"	384	
SP-2	1	*	4 561'-1"	375	
SP-3	1	*	4 544'-7"	364	
SP-4	1	*	4 530'-2"	354	
SP-5	4	**	5 1188'-6"	4958	
SPIRAL COLUMN REINFORCING STEEL				LBS.	6,435
* THE SP-1 THROUGH SP-4 SPIRAL REINFORCING STEEL SHALL BE W20 OR D-20 COLD DRAWN WIRE OR #4 PLAIN OR DEFORMED BAR.					
* THE SP-5 SPIRAL REINFORCING STEEL SHALL BE W31 OR D-31 COLD DRAWN WIRE OR #5 PLAIN OR DEFORMED BAR.					
CLASS A CONCRETE BREAKDOWN					
POUR #2 (COLUMNS)			C.Y.	16.9	
POUR #3 (CAP)			C.Y.	45.9	
TOTAL CLASS A CONCRETE			C.Y.	62.8	
DRILLED PIER QUANTITIES					
DRILLED PIER CONCRETE					
POUR #1 (DRILLED PIERS)			C.Y.	85.5	
3'-6" Ø DRILLED PIERS IN SOIL			LIN. FT.	180.00	
3'-6" Ø DRILLED PIER NOT IN SOILS			LIN. FT.	60.00	
PERMANENT STEEL CASING FOR 3'-6" Ø DRILLED PIERS			LIN. FT.	32.00	
SPT TESTING				4 EA.	
CSL TUBES			LIN. FT.	984.00	

PROJECT NO. U-2579C
 FORSYTH COUNTY
 STATION: 473+70.00 -L-

SHEET 2 OF 2

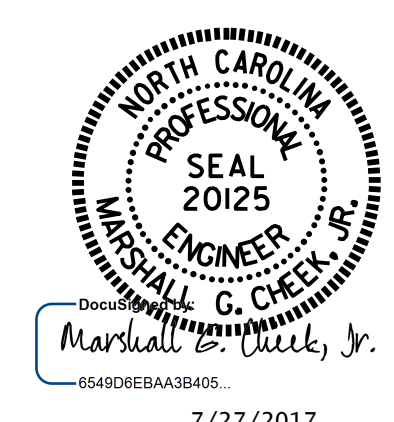

STATE OF NORTH CAROLINA
 DEPARTMENT OF TRANSPORTATION
 RALEIGH
 SUBSTRUCTURE
 BENT 1
 (RIGHT LANE)

DRAWN BY: ARIADNE L. PALMA P. DATE: 8-29-16
 CHECKED BY: M.K. BEARD DATE: 9-8-16
 DESIGN ENGINEER OF RECORD: H.A. LOCKLEAR DATE: 6/2017

DOCUMENT NOT CONSIDERED FINAL UNLESS ALL SIGNATURES COMPLETED

REVISIONS						SHEET NO.
NO.	BY:	DATE:	NO.	BY:	DATE:	S4-25
1			3			TOTAL SHEETS
2			4			33

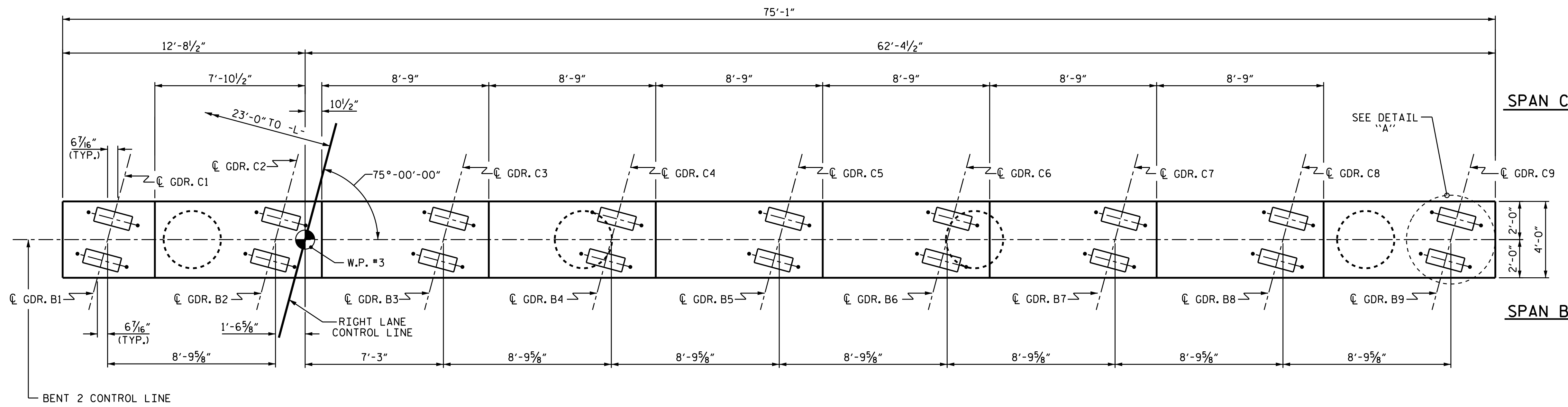

PLAN

NOTES

ALL STEEL IN THE DRILLED PIERS IS INCLUDED IN THE PAY ITEMS FOR "REINFORCING STEEL" AND "SPIRAL COLUMN REINFORCING STEEL".

THE CONTRACTOR'S ATTENTION IS CALLED TO THE FACT THAT THE LONGITUDINAL REINFORCEMENT FOR THE DRILLED PIERS IS DETAILED WITH 3 FEET OF EXTRA LENGTH.

THE LOCATION OF THE CONSTRUCTION JOINT IN THE DRILLED PIERS IS BASED ON AN APPROXIMATE GROUND LINE ELEVATION. IF THE CONSTRUCTION JOINT IS ABOVE THE ACTUAL GROUND LINE ELEVATION, THE CONTRACTOR SHALL PLACE THE CONSTRUCTION JOINT 1 FT. BELOW THE GROUND LINE.

STIRRUPS IN CAP MAY BE SHIFTED AS NECESSARY TO CLEAR ANCHOR BOLTS.

HOOKS ON "V" BARS MAY BE TURNED AS NECESSARY FOR PLACING REINFORCING STEEL.

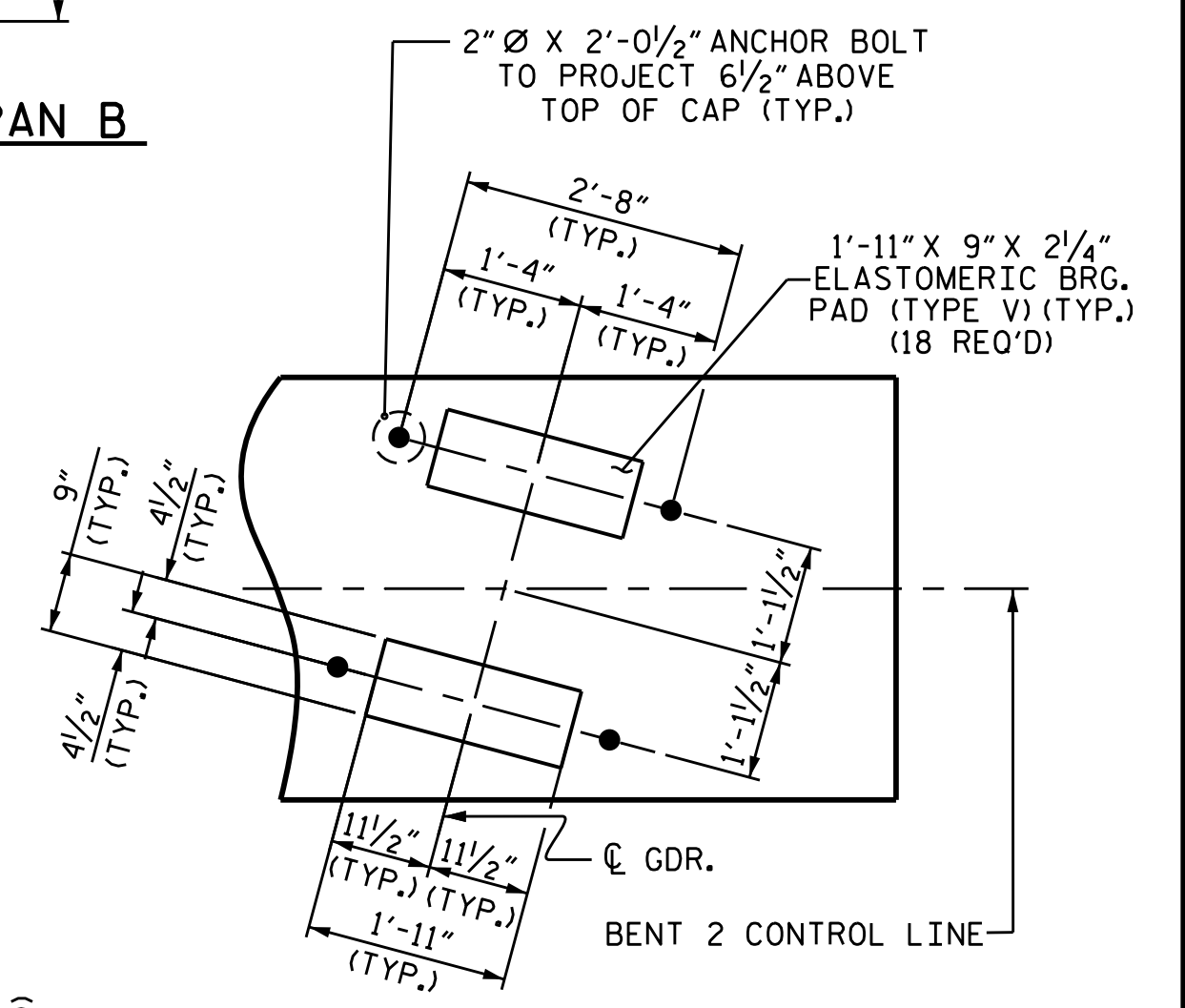

DETAIL "A"

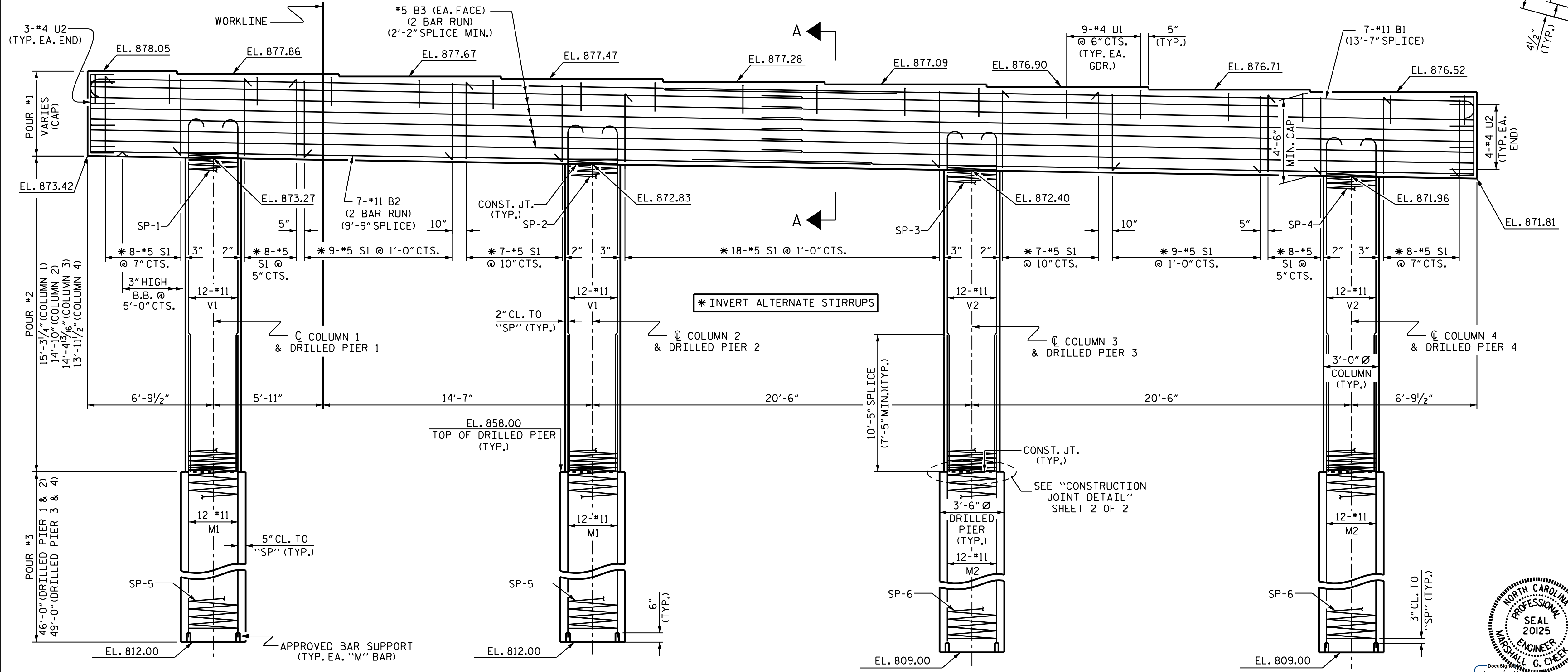

ELEVATION

PROJECT NO. U-2579C
 FORSYTH COUNTY
 STATION: 473+70.00 -L-

SHEET 1 OF 2

STATE OF NORTH CAROLINA
 DEPARTMENT OF TRANSPORTATION
 RALEIGH

SUBSTRUCTURE
 BENT 2
 (RIGHT LANE)



DRAWN BY: ARIADNE L. PALMA / TLA DATE: 7-29-16
 CHECKED BY: M.K. BEARD DATE: 9/8/16
 DESIGN ENGINEER OF RECORD: H.A. LOCKLEAR DATE: 6/2017

DOCUMENT NOT CONSIDERED
 FINAL UNLESS ALL
 SIGNATURES COMPLETED

REVISIONS						SHEET NO.
NO.	BY:	DATE:	NO.	BY:	DATE:	S4-26
1			3			TOTAL SHEETS
2			4			33

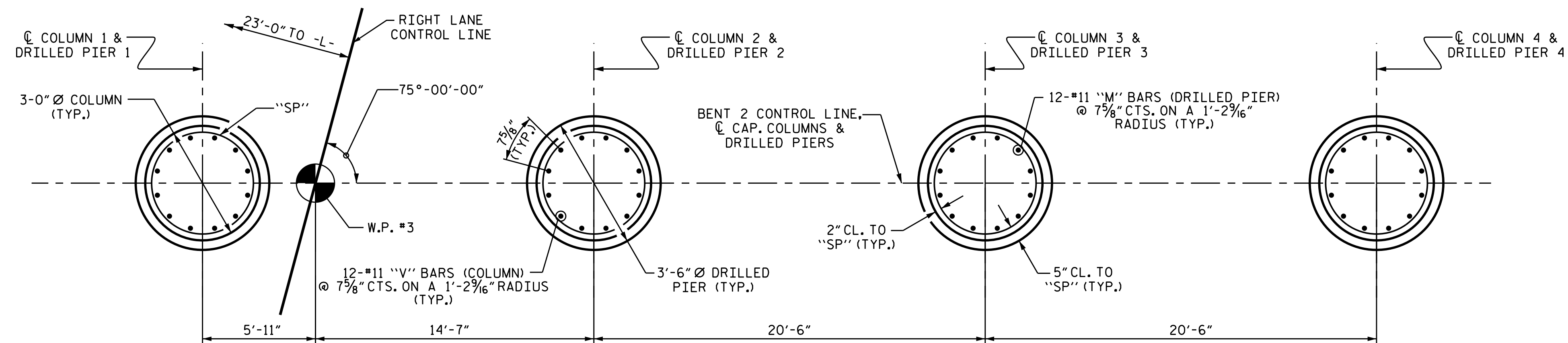

PLAN OF DRILLED PIERS & COLUMNS

DIMENSIONS AND REINFORCING STEEL ARE TYPICAL FOR EACH COLUMN & DRILLED PIER.

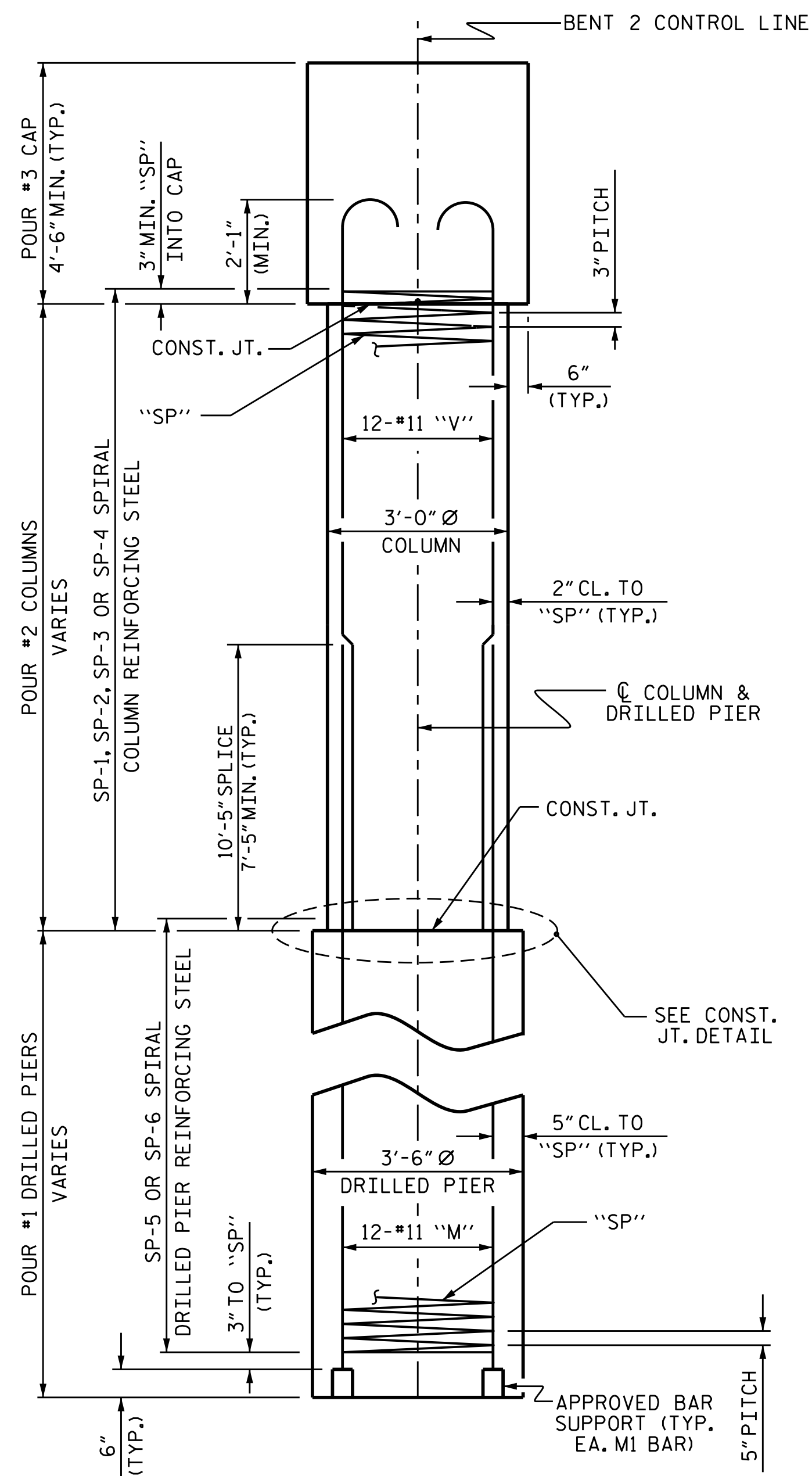

END ELEVATION

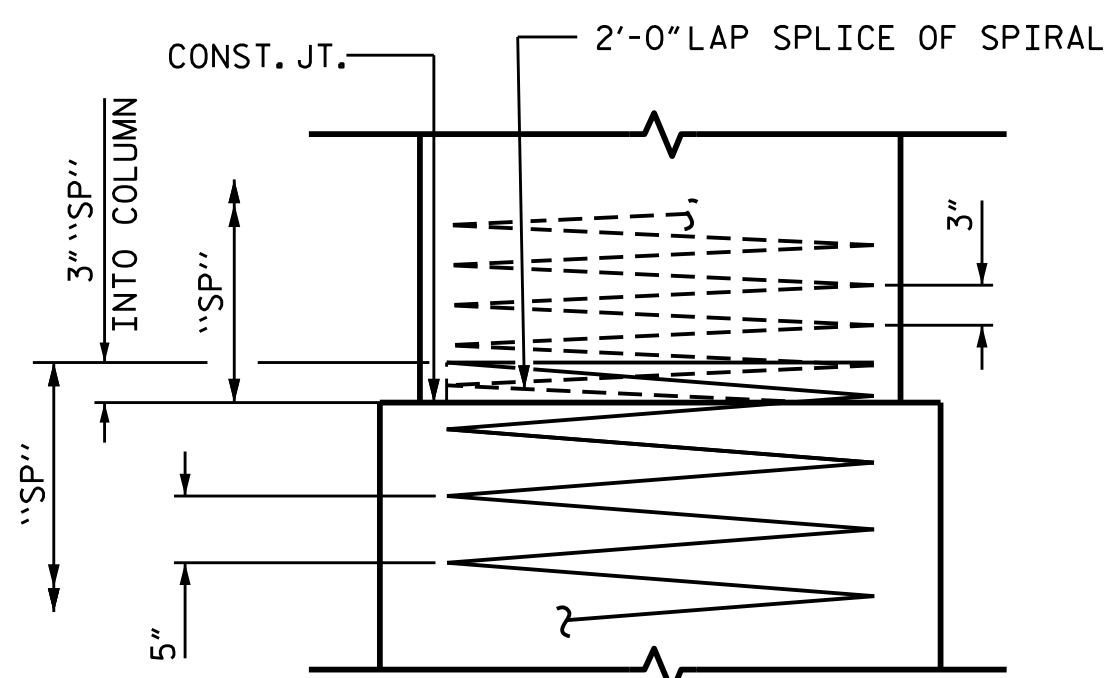

CONSTRUCTION JOINT DETAIL

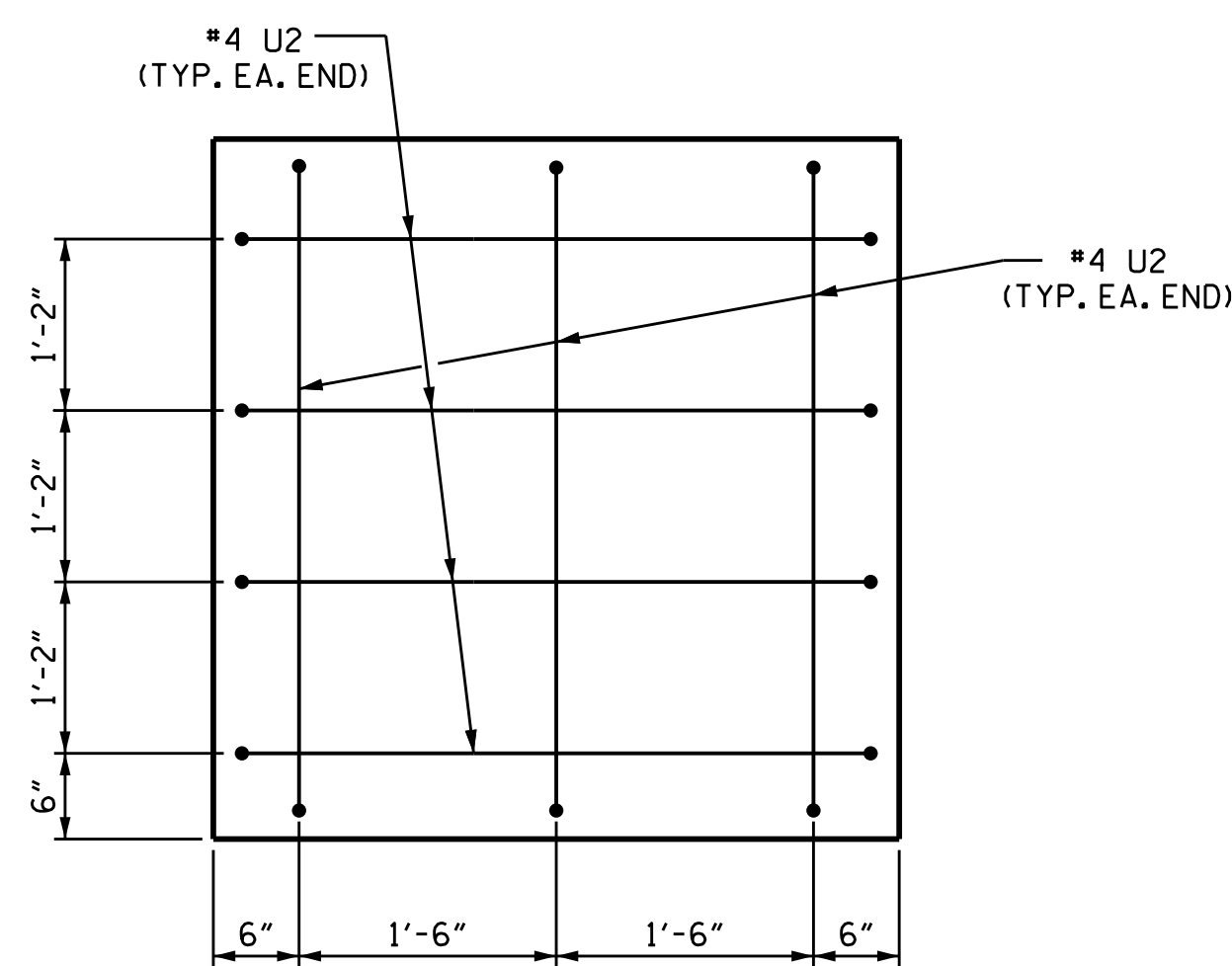

END OF CAP VIEW

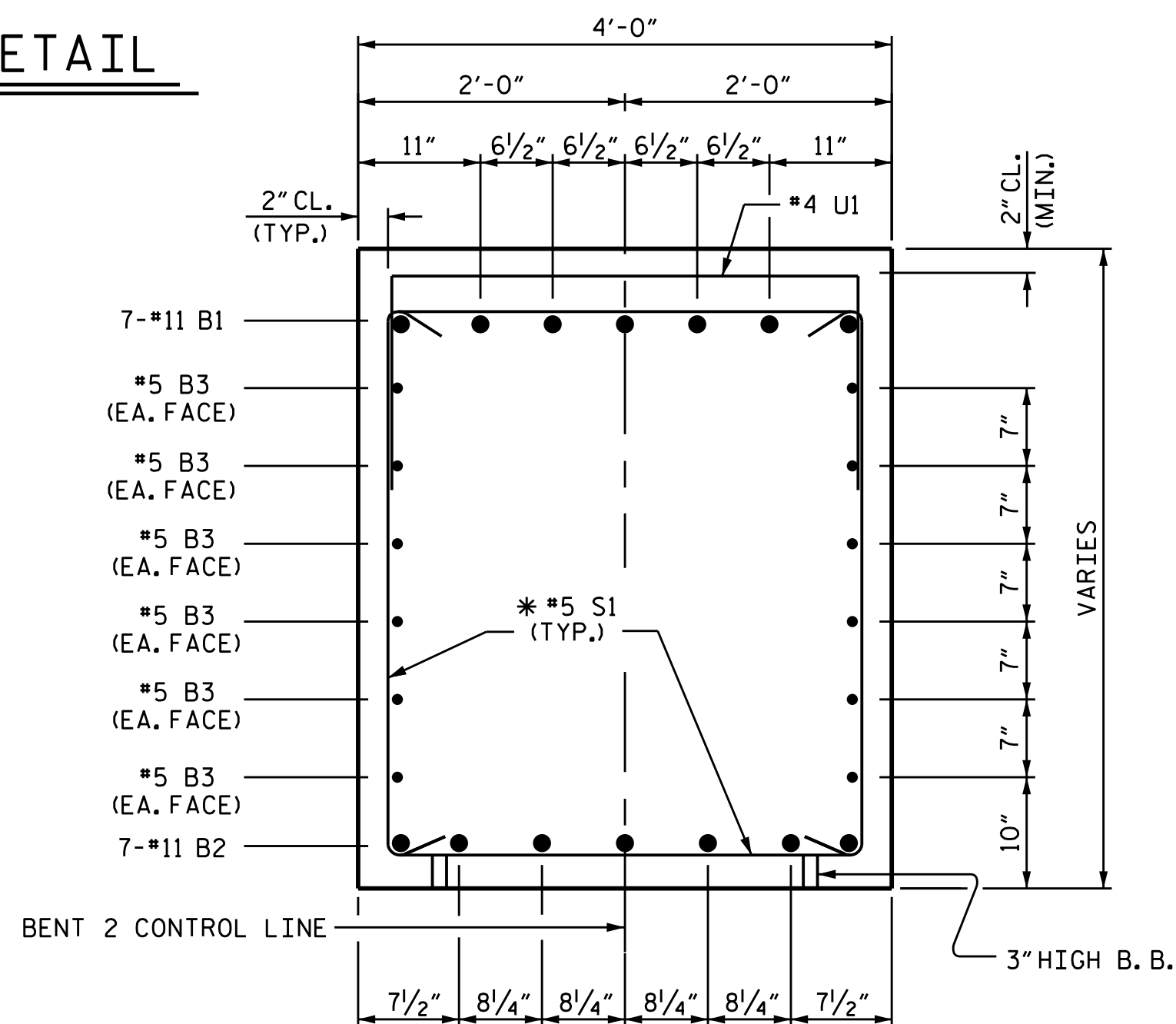

SECTION A-A

* INVERT ALTERNATE STIRRUPS

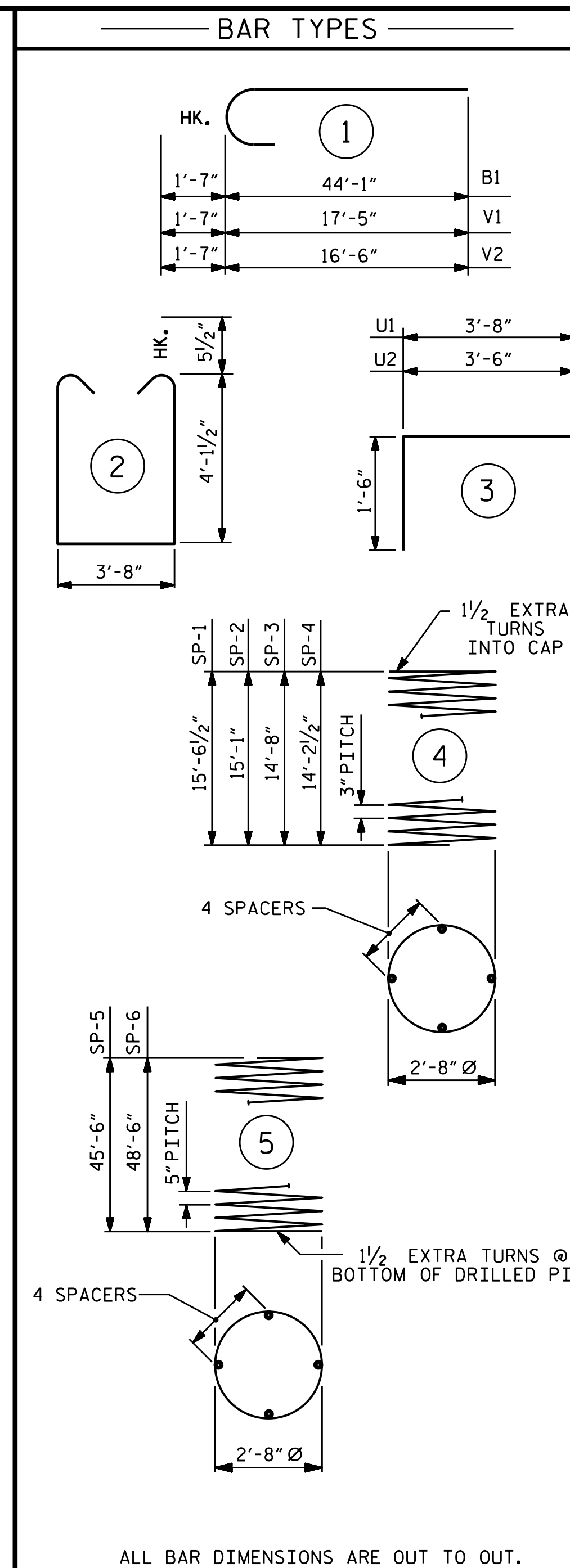

ALL BAR DIMENSIONS ARE OUT TO OUT.

BILL OF MATERIAL

BENT 2					
BAR	NO.	SIZE	TYPE	LENGTH	WEIGHT
B1	14	#11		45'-8"	3397
B2	14	#11	STR	42'-3"	3143
B3	24	#5	STR	38'-6"	964
M1	24	#11	STR	56'-2"	7162
M2	24	#11	STR	59'-2"	7544
S1	82	#5		12'-10"	1098
U1	81	#4		6'-8"	361
U2	14	#4		6'-6"	61
V1	24	#11		19'-0"	2423
V2	24	#11		18'-1"	2306
REINFORCING STEEL				LBS.	28,459

SPIRAL COLUMN REINFORCING STEEL					
SP	NO.	SIZE	TYPE	LENGTH	WEIGHT
SP-1	1	*	4	526'-0"	351
SP-2	1	*	4	511'-7"	342
SP-3	1	*	4	497'-2"	332
SP-4	1	*	4	482'-8"	322
SP-5	2	**	5	910'-11"	1900
SP-6	2	**	5	970'-6"	2024
SPIRAL COLUMN REINFORCING STEEL				LBS.	5,271

* THE SP-1 THROUGH SP-4 SPIRAL REINFORCING STEEL SHALL BE W20 OR D-20 COLD DRAWN WIRE OR #4 PLAIN OR DEFORMED BAR.
 ** THE SP-5 AND SP-6 SPIRAL REINFORCING STEEL SHALL BE W31 OR D-31 COLD DRAWN WIRE OR #5 PLAIN OR DEFORMED BAR.

CLASS A CONCRETE BREAKDOWN		
POUR #2 (COLUMNS)	C.Y.	15.3
POUR #3 (CAP)	C.Y.	51.5
TOTAL CLASS A CONCRETE	C.Y.	66.8

DRILLED PIER QUANTITIES		
DRILLED PIER CONCRETE		
POUR #1 (DRILLED PIERS)	C.Y.	67.7
3'-6" Ø DRILLED PIERS IN SOIL	LIN. FT.	122.00
3'-6" Ø DRILLED PIERS NOT IN SOIL	LIN. FT.	68.00
PERMANENT STEEL CASING FOR 3'-6" Ø DRILLED PIERS	LIN. FT.	32.00
SPT TESTING		4 EA.
CSL TUBES		LIN. FT. 784.00

PROJECT NO. U-2579C
 FORSYTH COUNTY
 STATION: 473+70.00 -L-
 SHEET 2 OF 2

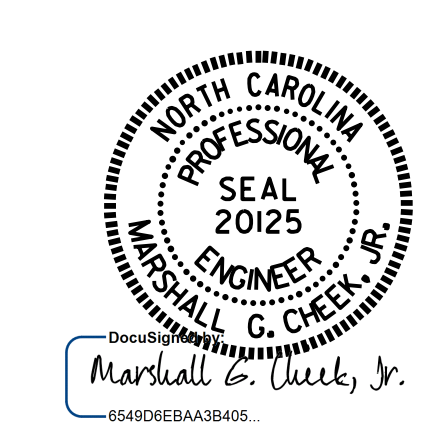

STATE OF NORTH CAROLINA
 DEPARTMENT OF TRANSPORTATION
 RALEIGH
 SUBSTRUCTURE
 BENT 2
 (RIGHT LANE)

DRAWN BY: ARIADNE L. PALMA / TLA DATE: 7-27-16
 CHECKED BY: M.K. BEARD DATE: 9/8/16
 DESIGN ENGINEER OF RECORD: H.A. LOCKLEAR DATE: 6/2017

DOCUMENT NOT CONSIDERED FINAL UNLESS ALL SIGNATURES COMPLETED

REVISIONS						SHEET NO.
NO.	BY:	DATE:	NO.	BY:	DATE:	S4-27
1			3			TOTAL SHEETS 33
2			4			

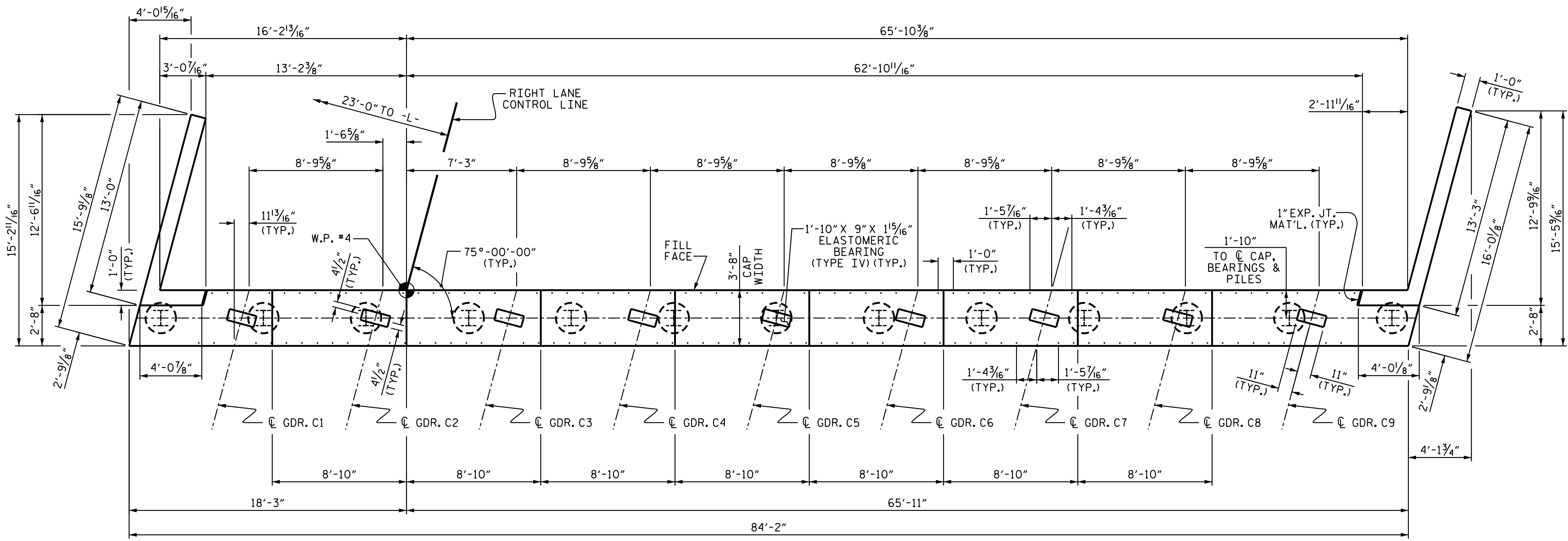

NOTES
 THE TOP SURFACE OF THE END BENT CAP, EXCEPT THE BEARING AREA, SHALL BE RAKED TO A DEPTH OF 1/4".

TOP OF PILE ELEVATIONS	
①	875.44
②	875.30
③	875.16
④	875.02
⑤	874.88
⑥	874.74
⑦	874.60
⑧	874.46
⑨	874.32
⑩	874.18
⑪	874.04
⑫	873.90
⑬	873.76

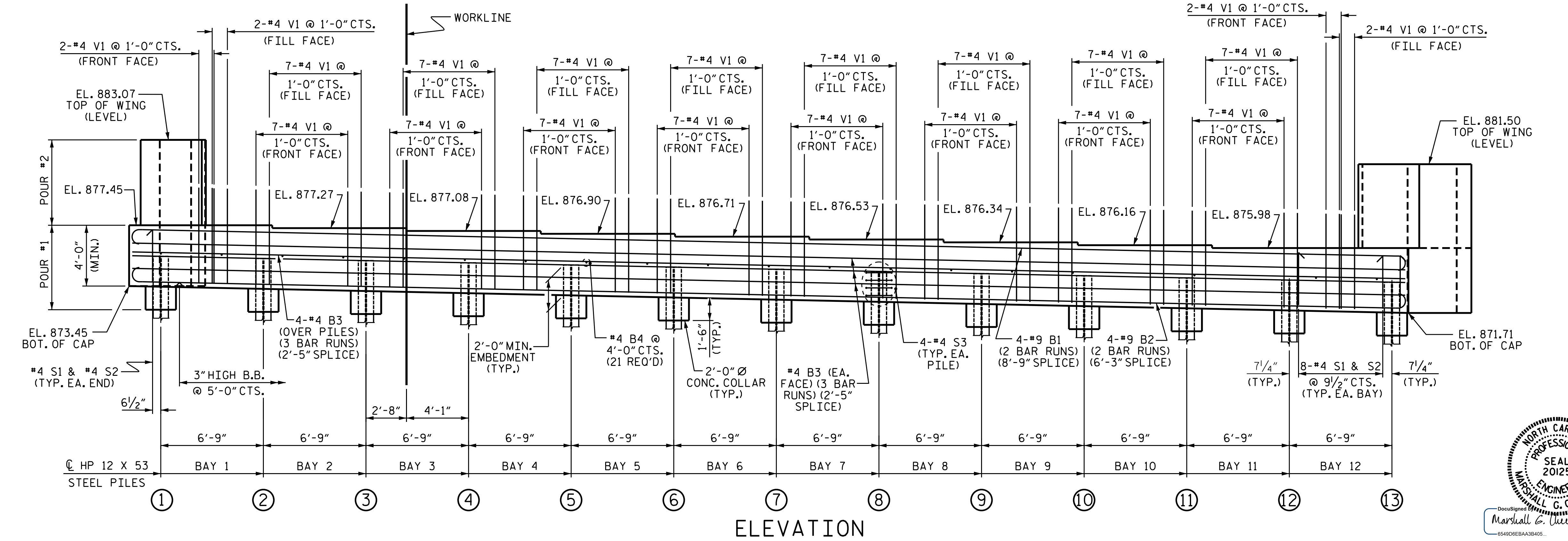

PROJECT NO. U-2579C
 FORSYTH COUNTY
 STATION: 473+70.00 -L-

SHEET 1 OF 3
 DEPARTMENT OF NORTH CAROLINA TRANSPORTATION
 RALEIGH
 SUBSTRUCTURE
 INTEGRAL END BENT 2
 (RIGHT LANE)



DRAWN BY: H.A. LOCKLEAR DATE: 6/29/16
 CHECKED BY: K.D. LAYNE DATE: 8/3/16
 DESIGN ENGINEER OF RECORD: H.A. LOCKLEAR DATE: 8/18/16

DOCUMENT NOT CONSIDERED FINAL UNLESS ALL SIGNATURES COMPLETED

REVISIONS						SHEET NO.	
NO.	BY:	DATE:	NO.	BY:	DATE:	S4-28	
1			3			TOTAL SHEETS	33
2			4				

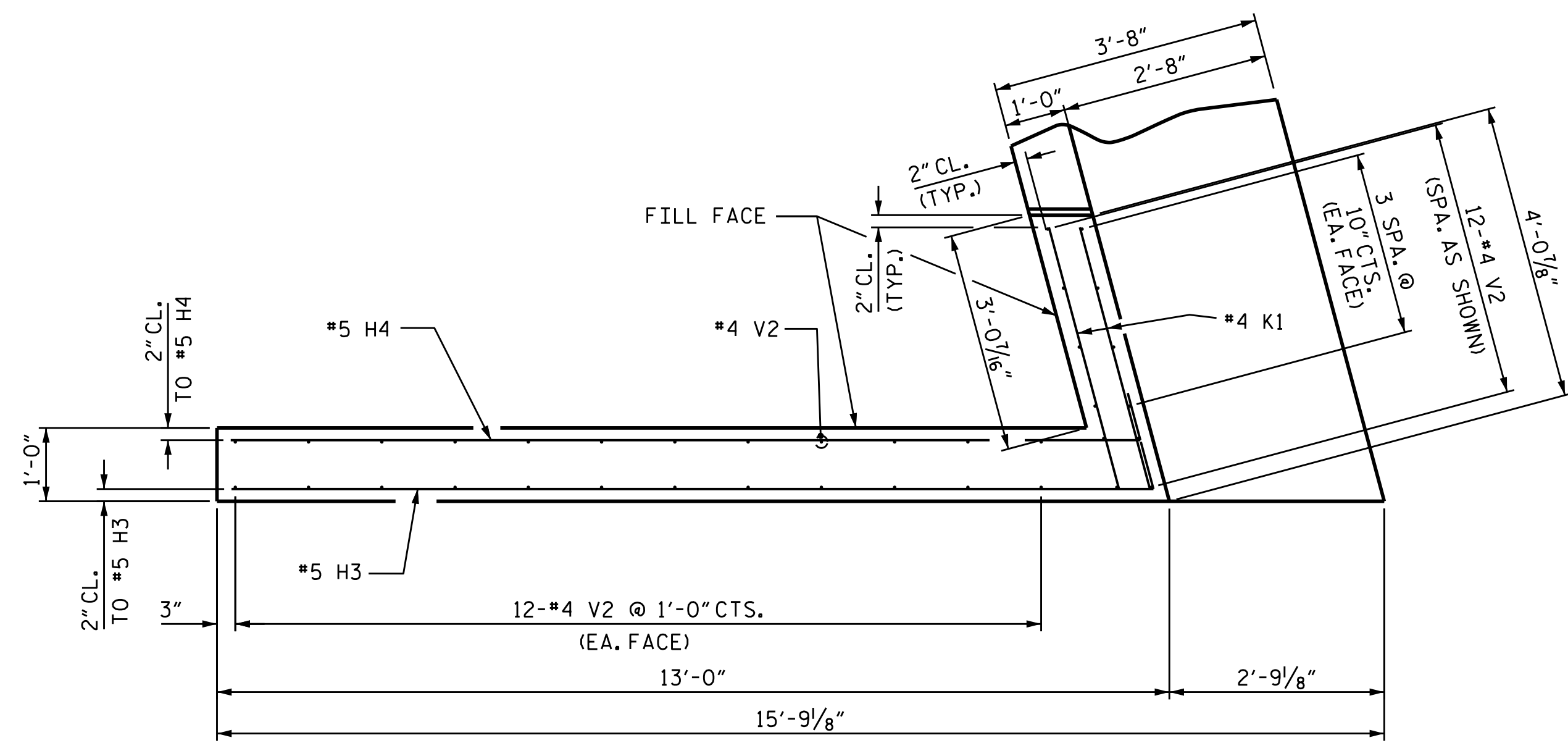

PLAN OF LEFT WING

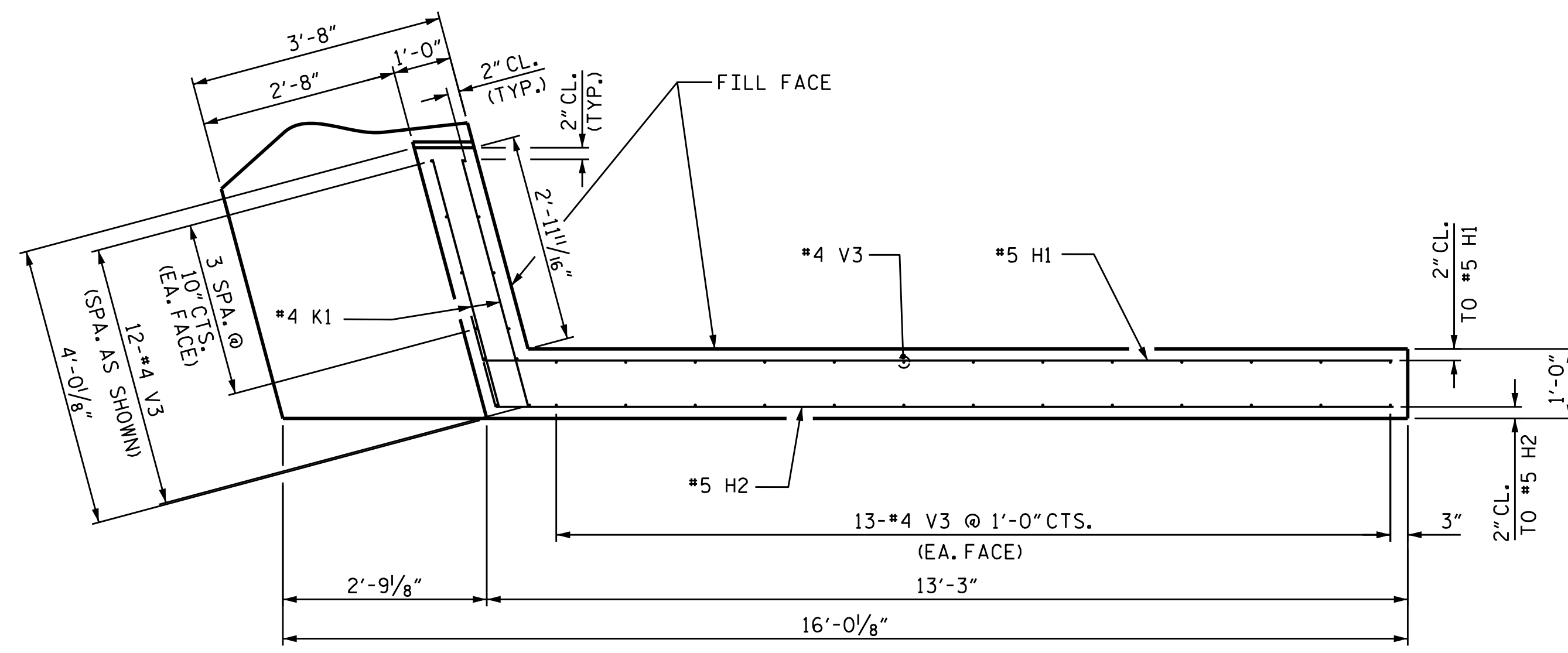

PLAN OF RIGHT WING

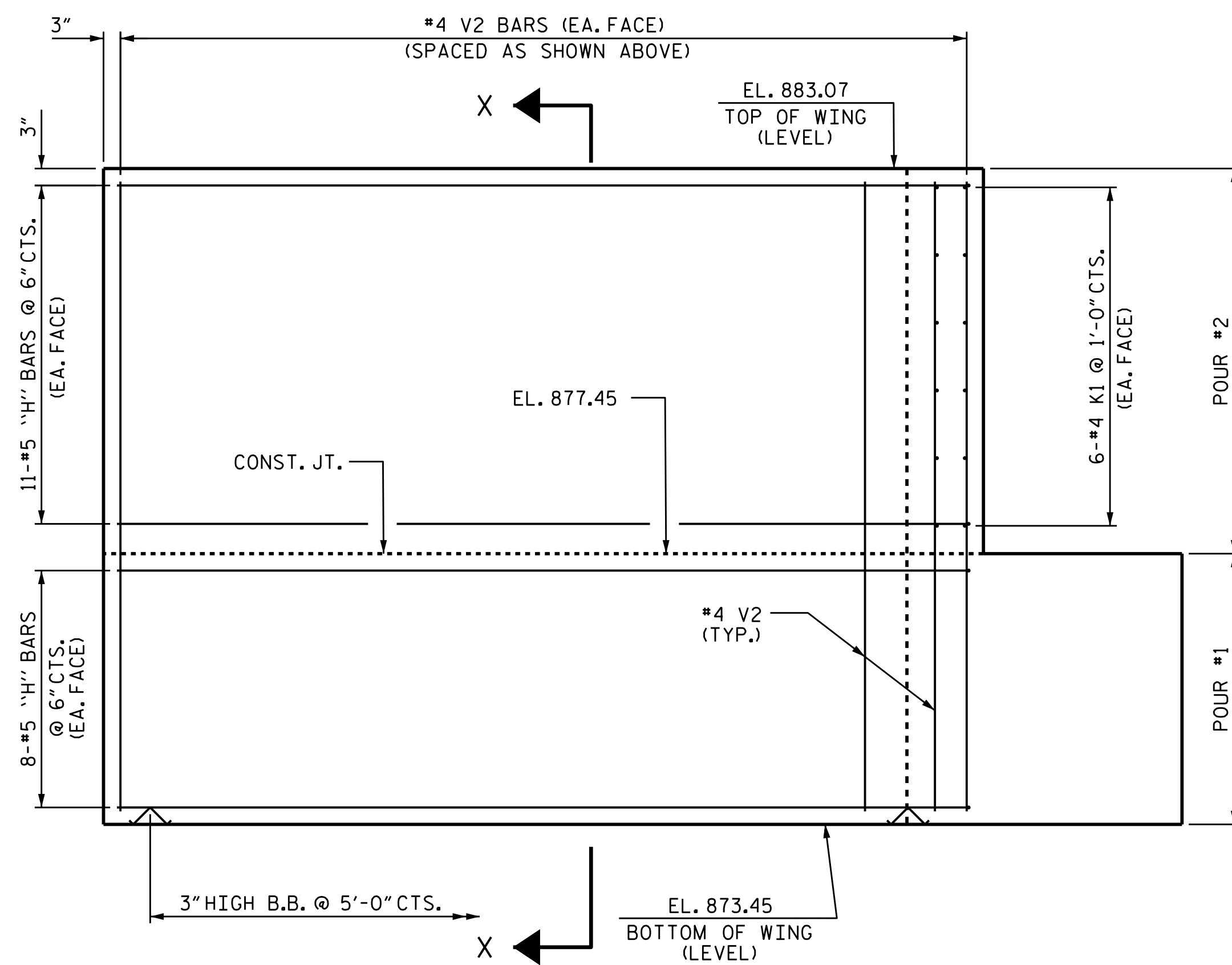

ELEVATION OF LEFT WING

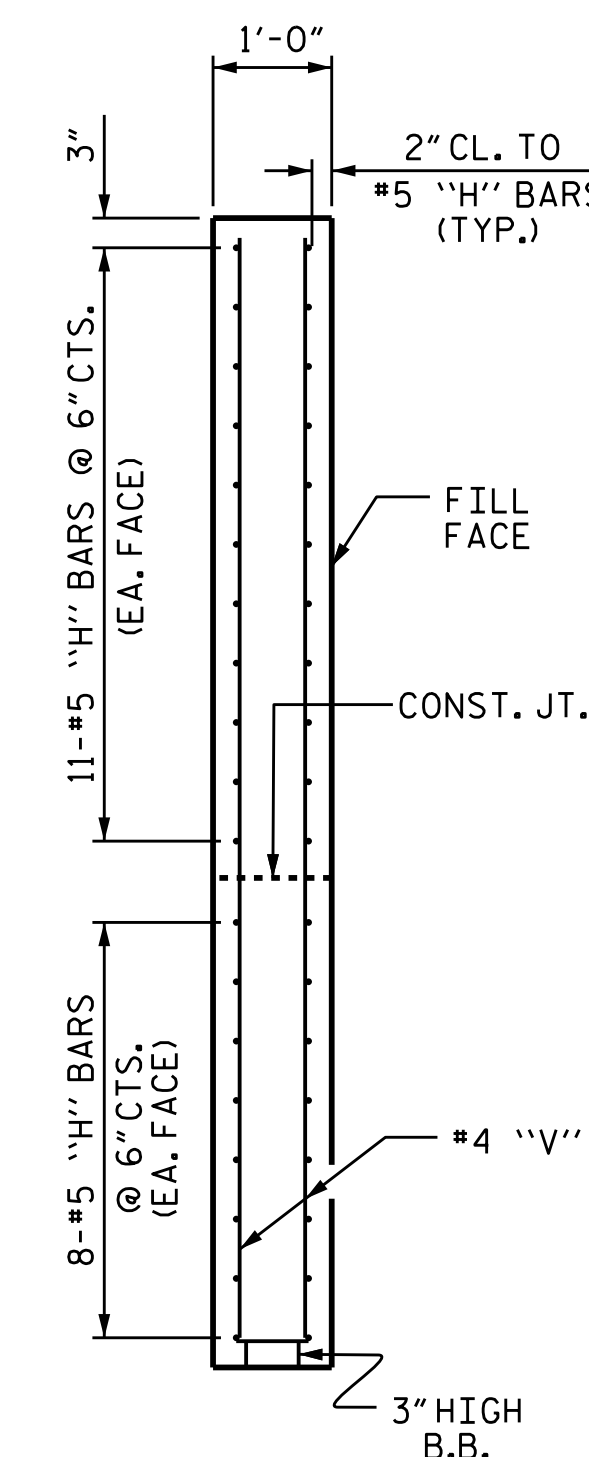

SECTION X-X

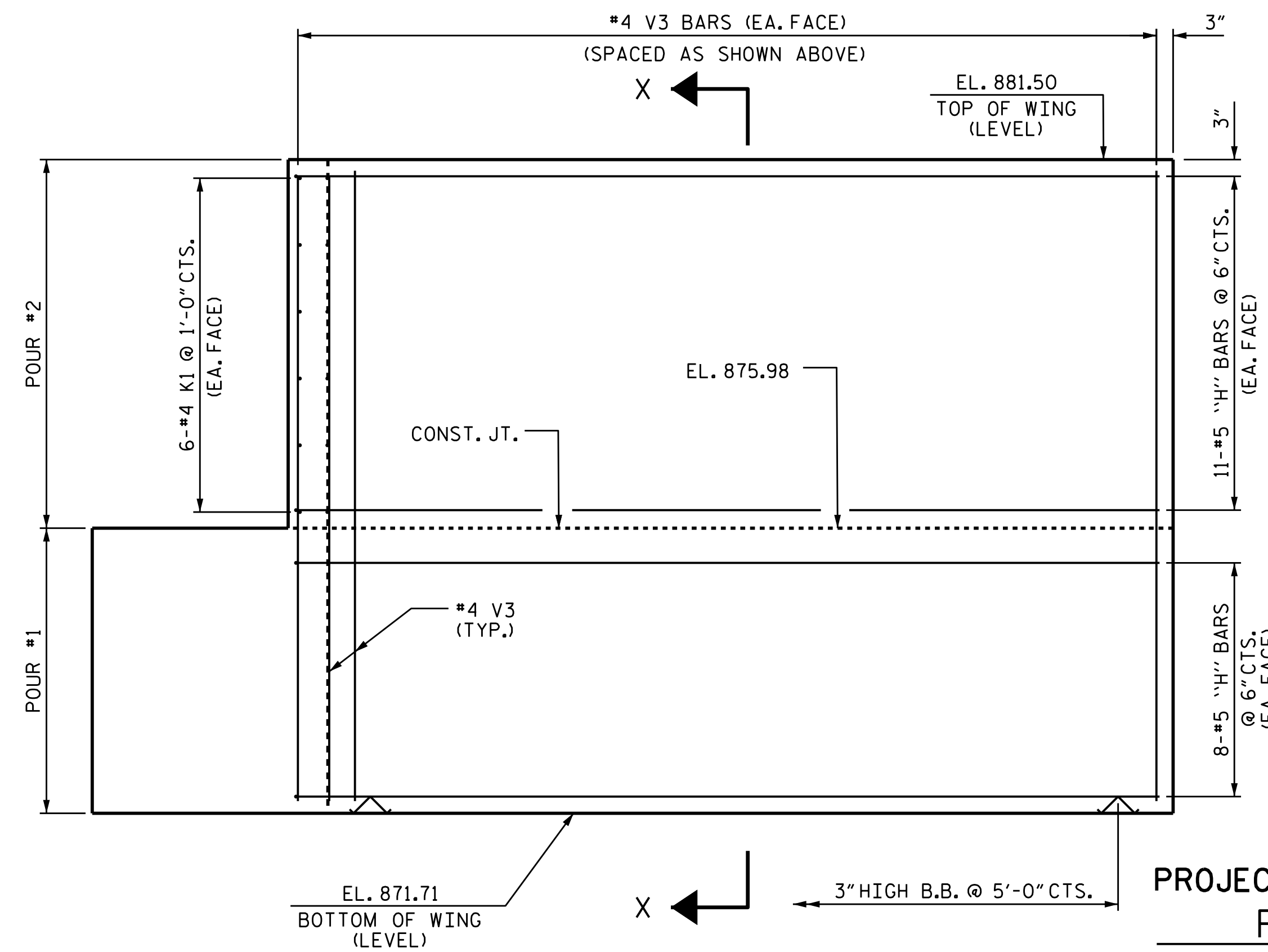

ELEVATION OF RIGHT WING

PROJECT NO. U-2579C
FORSYTH COUNTY
 STATION: 473+70.00 -L-

SHEET 2 OF 3



STATE OF NORTH CAROLINA
 DEPARTMENT OF TRANSPORTATION
 RALEIGH
 SUBSTRUCTURE
 INTEGRAL
 END BENT 2
 (RIGHT LANE)

DRAWN BY : H.A. LOCKLEAR DATE : 6/22/16
 CHECKED BY : K.D. LAYNE DATE : 8/3/16
 DESIGN ENGINEER OF RECORD: H.A. LOCKLEAR DATE : 8/18/16

DOCUMENT NOT CONSIDERED
 FINAL UNLESS ALL
 SIGNATURES COMPLETED

REVISIONS						SHEET NO.	
NO.	BY:	DATE:	NO.	BY:	DATE:	S4-29	
1			3			TOTAL SHEETS	
2			4			33	

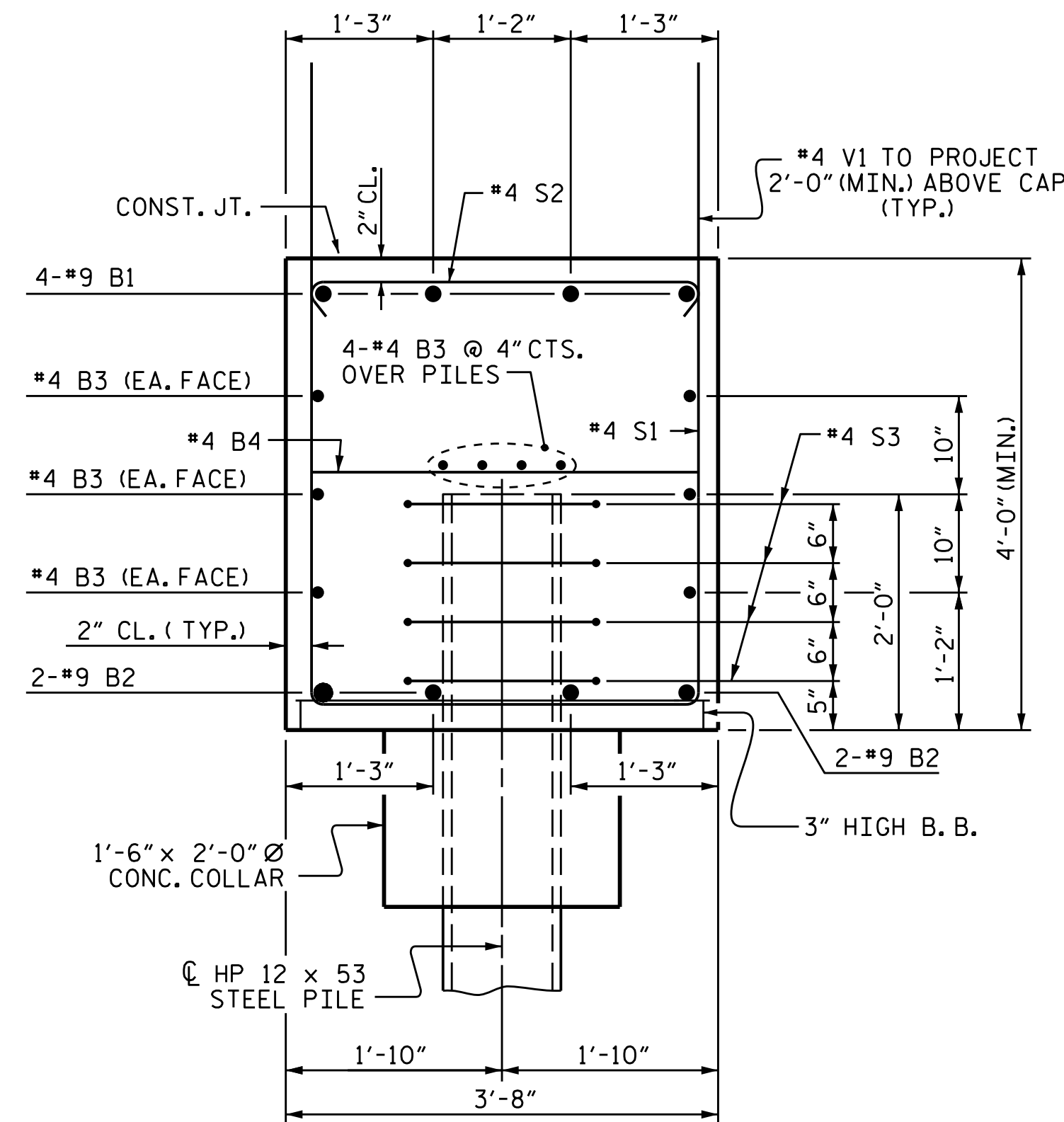

SECTION THRU CAP

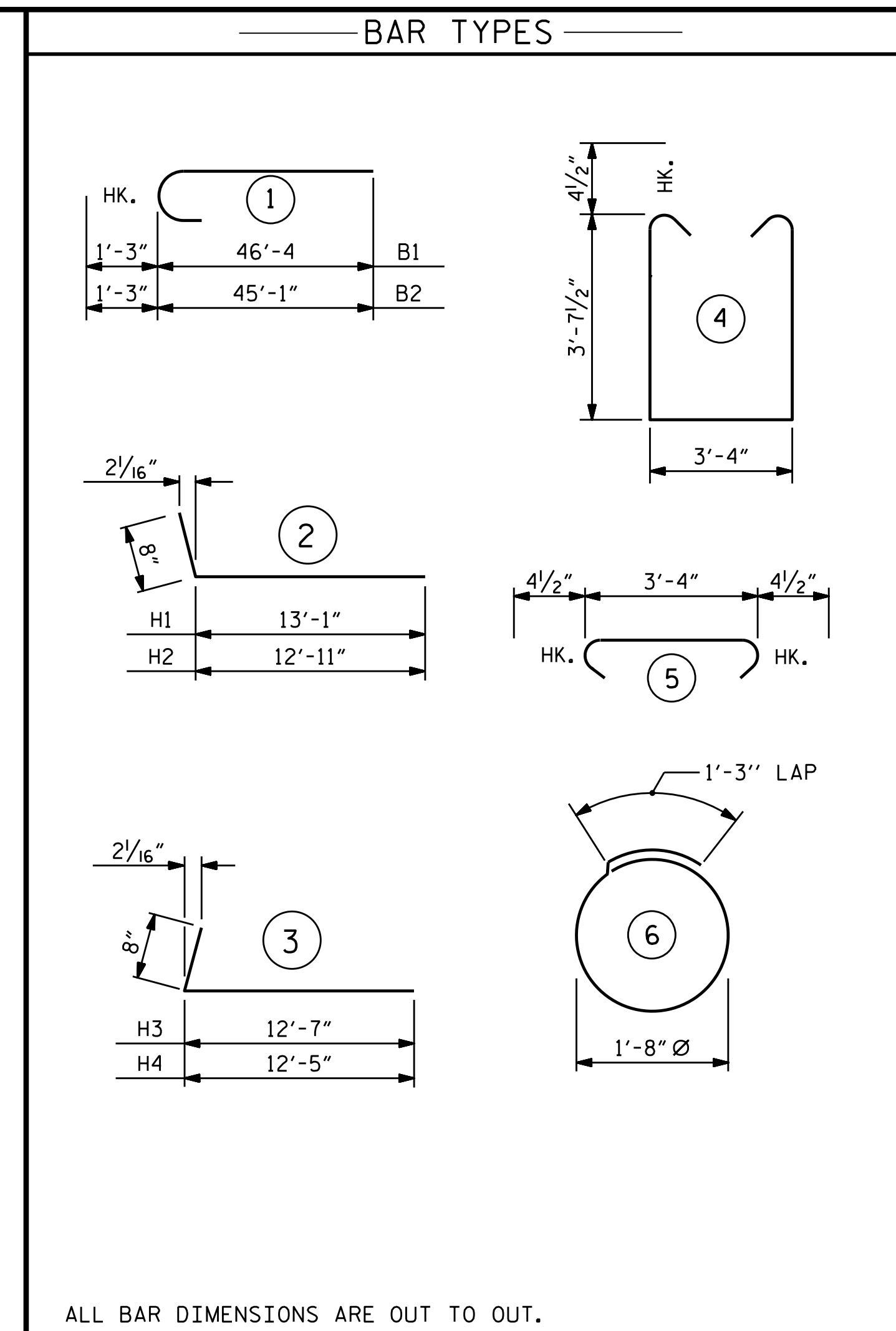

BILL OF MATERIAL					
INTEGRAL END BENT 2					
BAR	NO.	SIZE	TYPE	LENGTH	WEIGHT
B1	8	#9	1	47'-7"	1294
B2	8	#9	1	46'-4"	1260
B3	30	#4	STR	29'-7"	593
B4	21	#4	STR	3'-4"	47
H1	19	#5	2	13'-9"	272
H2	19	#5	2	13'-7"	269
H3	19	#5	3	13'-3"	263
H4	19	#5	3	13'-1"	259
K1	24	#4	STR	3'-8"	59
S1	98	#4	4	11'-4"	742
S2	98	#4	5	4'-1"	267
S3	52	#4	6	6'-6"	226
V1	120	#4	STR	6'-0"	481
V2	36	#4	STR	9'-3"	222
V3	38	#4	STR	9'-5"	239
REINFORCING STEEL					LBS. 6493
CLASS A CONCRETE					
POUR #1 CAP, LOWER WINGS & CONC. COLLARS				C.Y.	52.8
POUR #2 UPPER PART OF WINGS				C.Y.	6.7
TOTAL CLASS A CONCRETE				C.Y.	59.5
HP 12 X 53 STEEL PILES					
NO.: 13				LIN. FT.	685
PILE DRIVING EQUIPMENT SETUP FOR HP 12 X 53 STEEL PILES					
				EACH	13

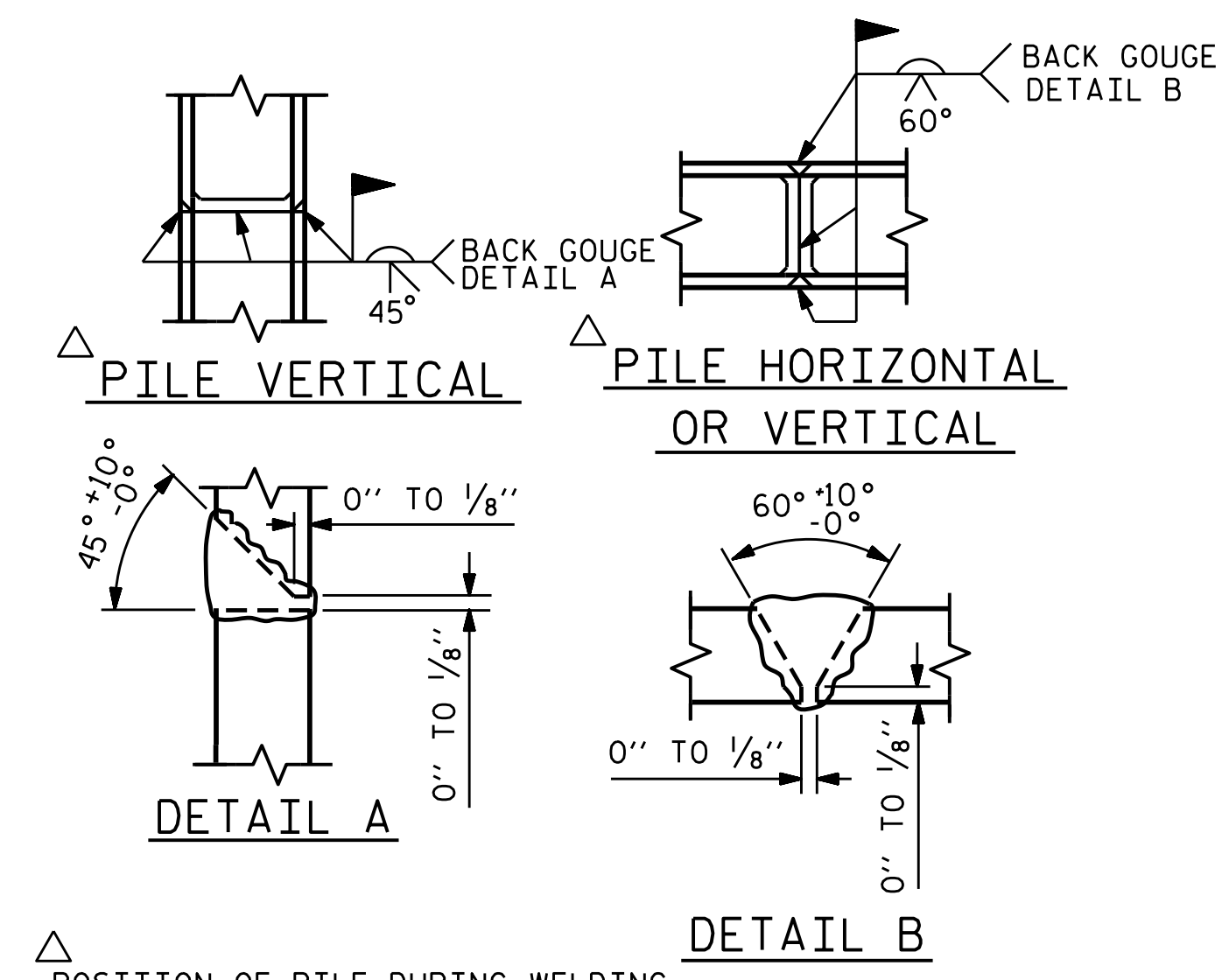

PILE SPLICE DETAILS

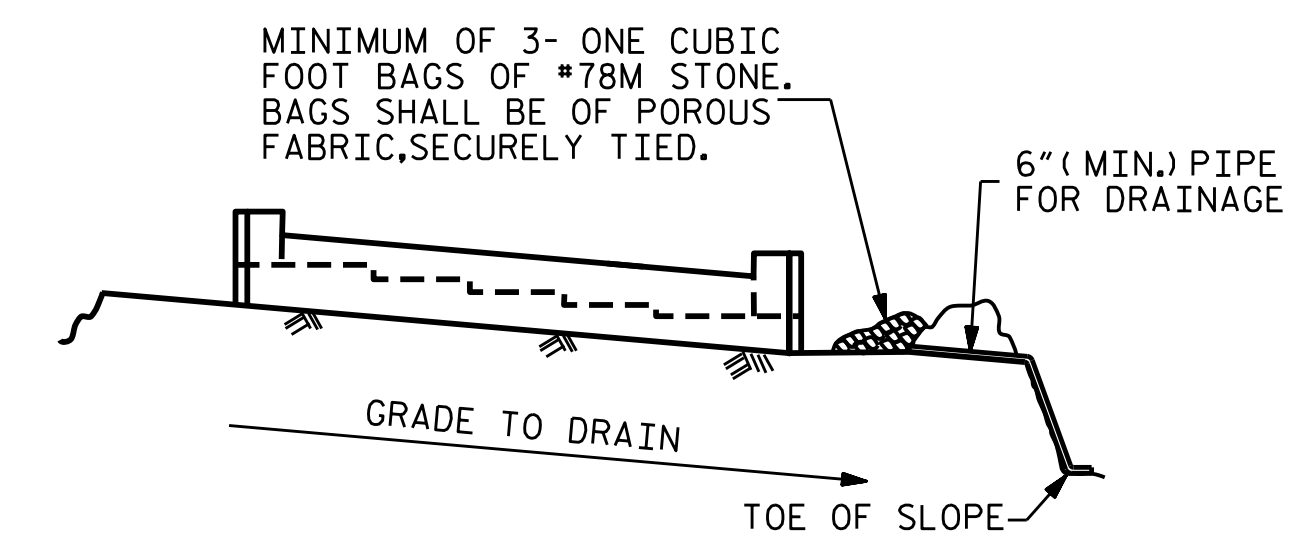

BAGGED STONE AND PIPE SHALL BE PLACED IMMEDIATELY AFTER COMPLETION OF END BENT EXCAVATION. PIPE MAY BE EITHER CONCRETE, CORRUGATED STEEL, CORRUGATED ALUMINUM ALLOY, OR CORRUGATED PLASTIC. PERFORATED PIPE WILL NOT BE ALLOWED.

BAGGED STONE SHALL REMAIN IN PLACE UNTIL THE ENGINEER DIRECTS THAT IT BE REMOVED. THE CONTRACTOR SHALL REMOVE AND DISPOSE OF SILT ACCUMULATIONS AT BAGGED STONE WHEN SO DIRECTED BY THE ENGINEER. BAGS SHALL BE REMOVED AND REPLACED WHENEVER THE ENGINEER DETERMINES THAT THEY HAVE DETERIORATED AND LOST THEIR EFFECTIVENESS.

NO SEPARATE PAYMENT WILL BE MADE FOR THIS WORK AND THE ENTIRE COST OF THIS WORK SHALL BE INCLUDED IN THE UNIT CONTRACT PRICE BID FOR THE SEVERAL PAY ITEMS.

TEMPORARY DRAINAGE AT END BENT

PROJECT NO. U-2579C
FORSYTH COUNTY
 STATION: 473+70.00 -L-

SHEET 3 OF 3

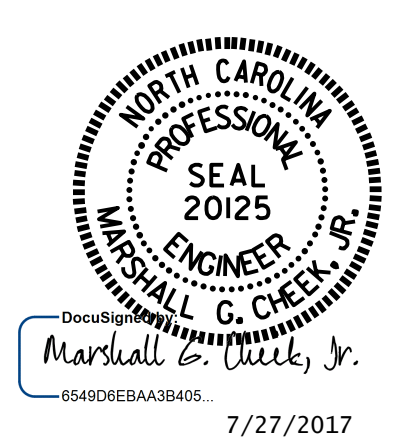

STATE OF NORTH CAROLINA
 DEPARTMENT OF TRANSPORTATION
 RALEIGH
 SUBSTRUCTURE
 INTEGRAL
 END BENT 2
 (RIGHT LANE)

DRAWN BY : H.A. LOCKLEAR DATE : 6/23/16
 CHECKED BY : K.D. LAYNE DATE : 8/3/16
 DESIGN ENGINEER OF RECORD: H.A. LOCKLEAR DATE : 8/18/16

DOCUMENT NOT CONSIDERED FINAL UNLESS ALL SIGNATURES COMPLETED

REVISIONS						SHEET NO.	
NO.	BY:	DATE:	NO.	BY:	DATE:	S4-30	
1			3			TOTAL SHEETS	33
2			4				

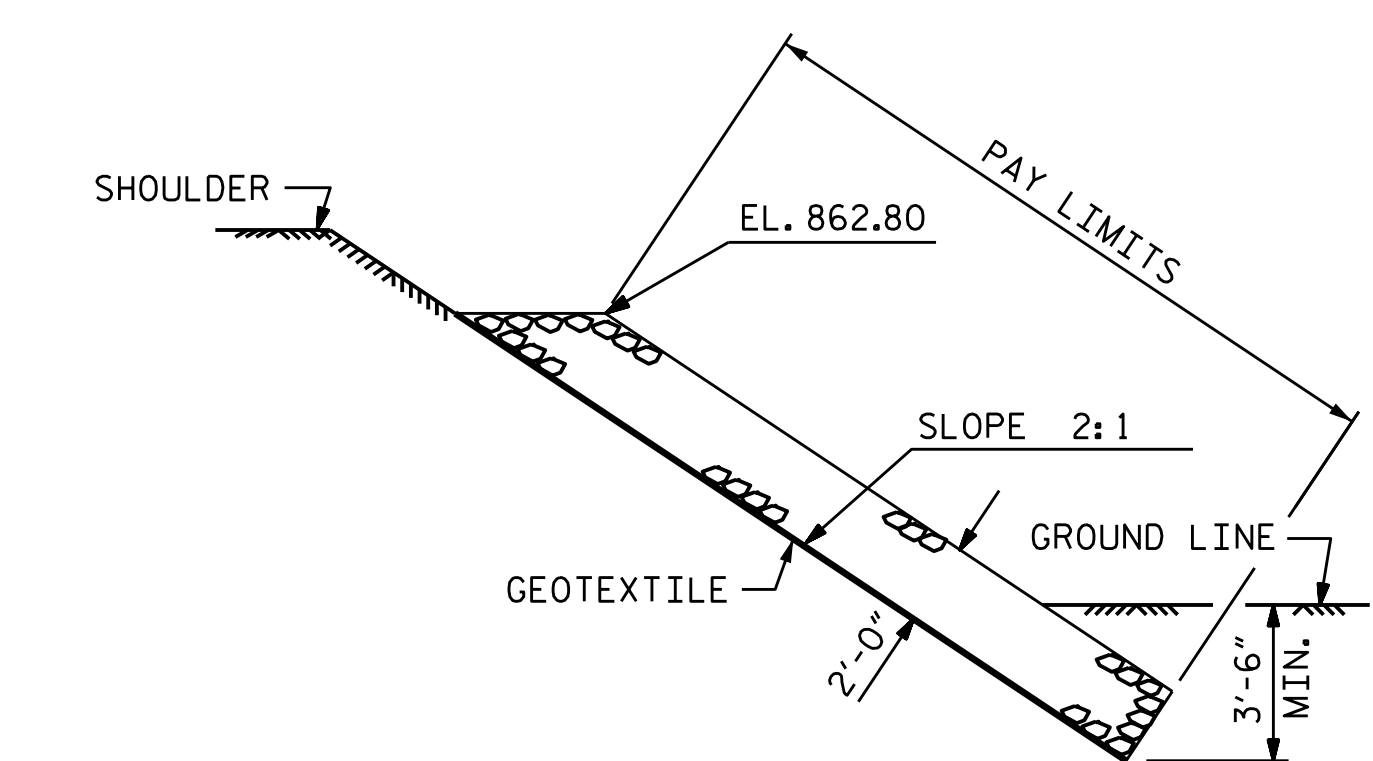
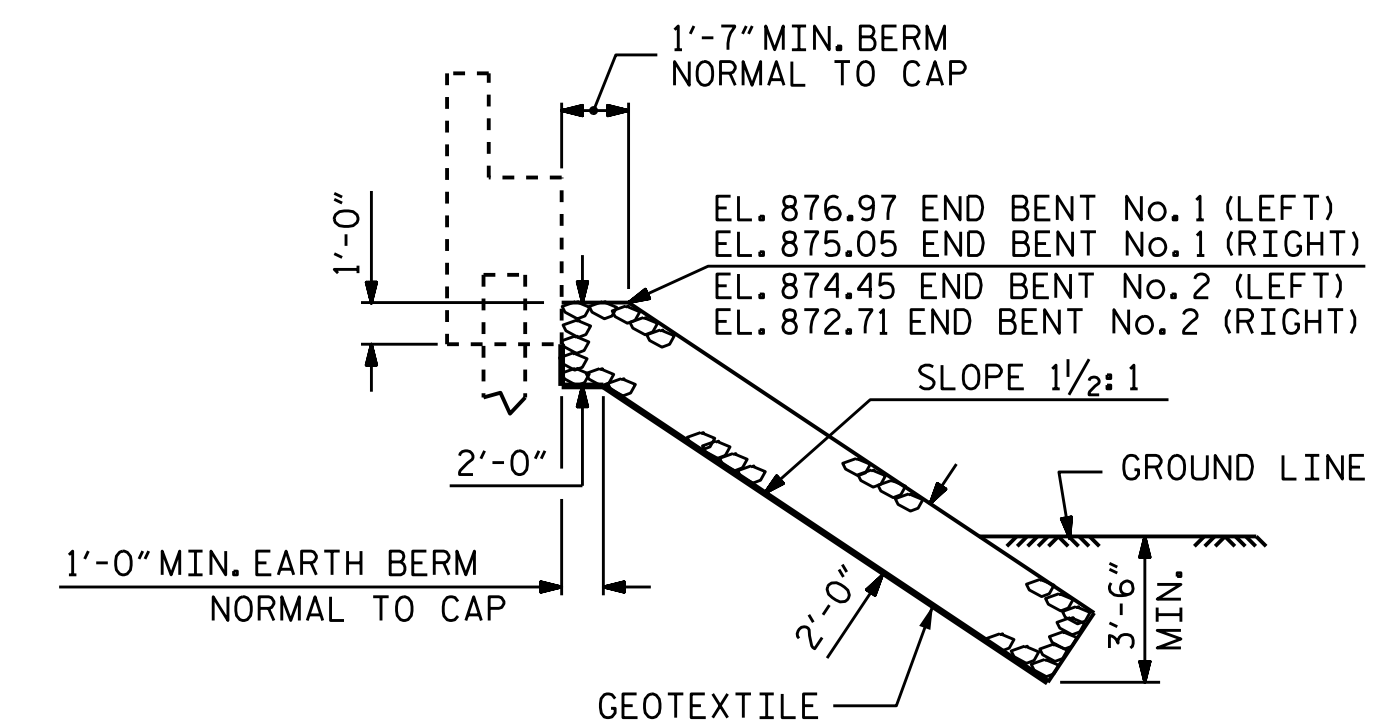
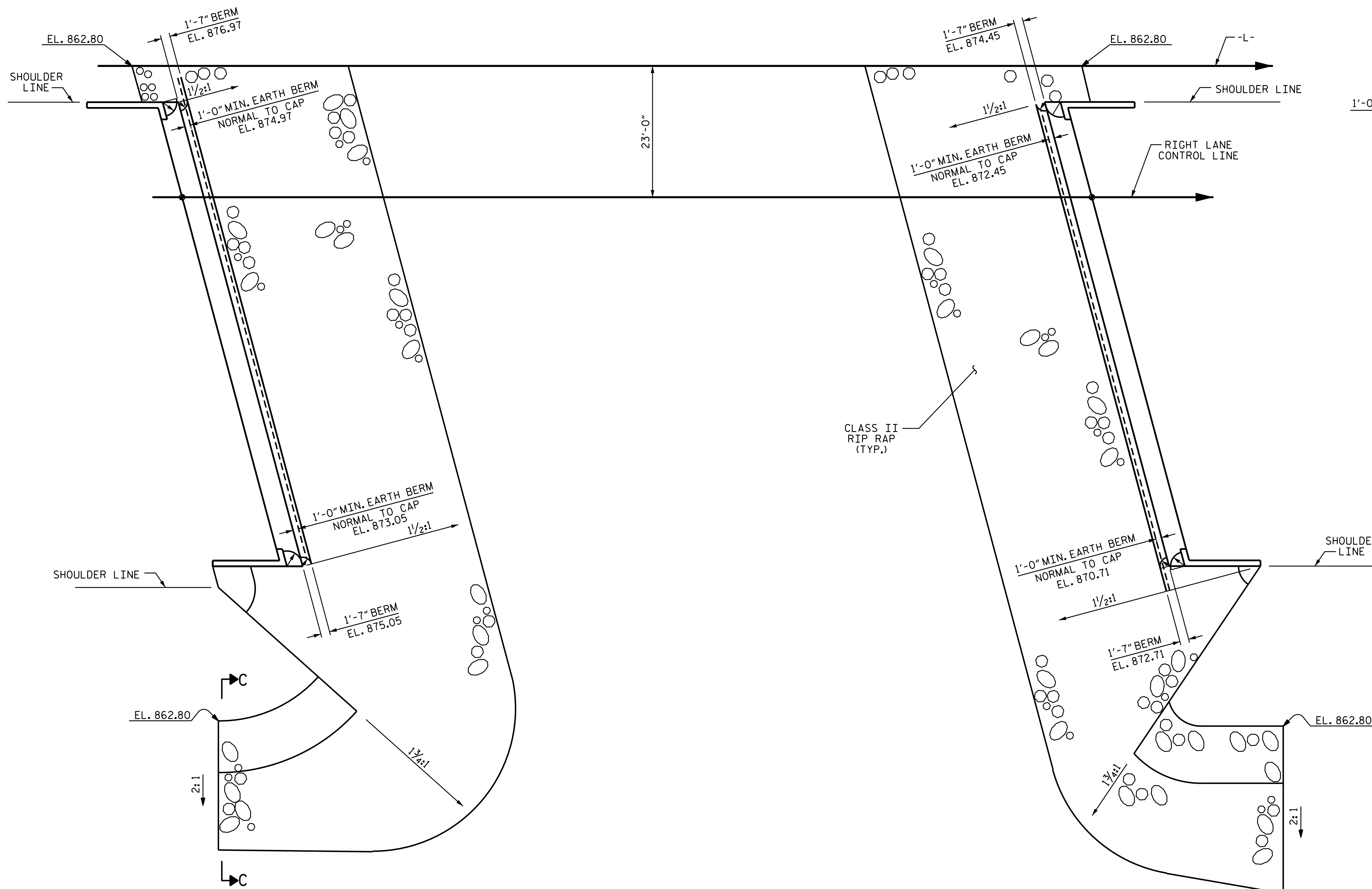

END BENT 1

END BENT 2

ESTIMATED QUANTITIES		
BRIDGE @ STA. 473+70.00 -L- (RIGHT LANE)	RIP RAP CLASS II (2'-0" THICK)	GEOTEXTILE FOR DRAINAGE
	TONS	SQUARE YARDS
END BENT 1	470	520
END BENT 2	485	540
TOTAL	955	1060

PROJECT NO. U-2579C
FORSYTH COUNTY
 STATION: 473+70.00 -L-



STATE OF NORTH CAROLINA
 DEPARTMENT OF TRANSPORTATION
 RALEIGH

**RIP RAP
 DETAILS
 (RIGHT LANE)**

DRAWN BY : H. T. BARBOUR DATE : 3-6-17
 CHECKED BY : A. SORSENGINH DATE : 3-17

DOCUMENT NOT CONSIDERED
 FINAL UNLESS ALL
 SIGNATURES COMPLETED

REVISIONS						SHEET NO.
NO.	BY:	DATE:	NO.	BY:	DATE:	TOTAL SHEETS
1			3			S4-31
2			4			33

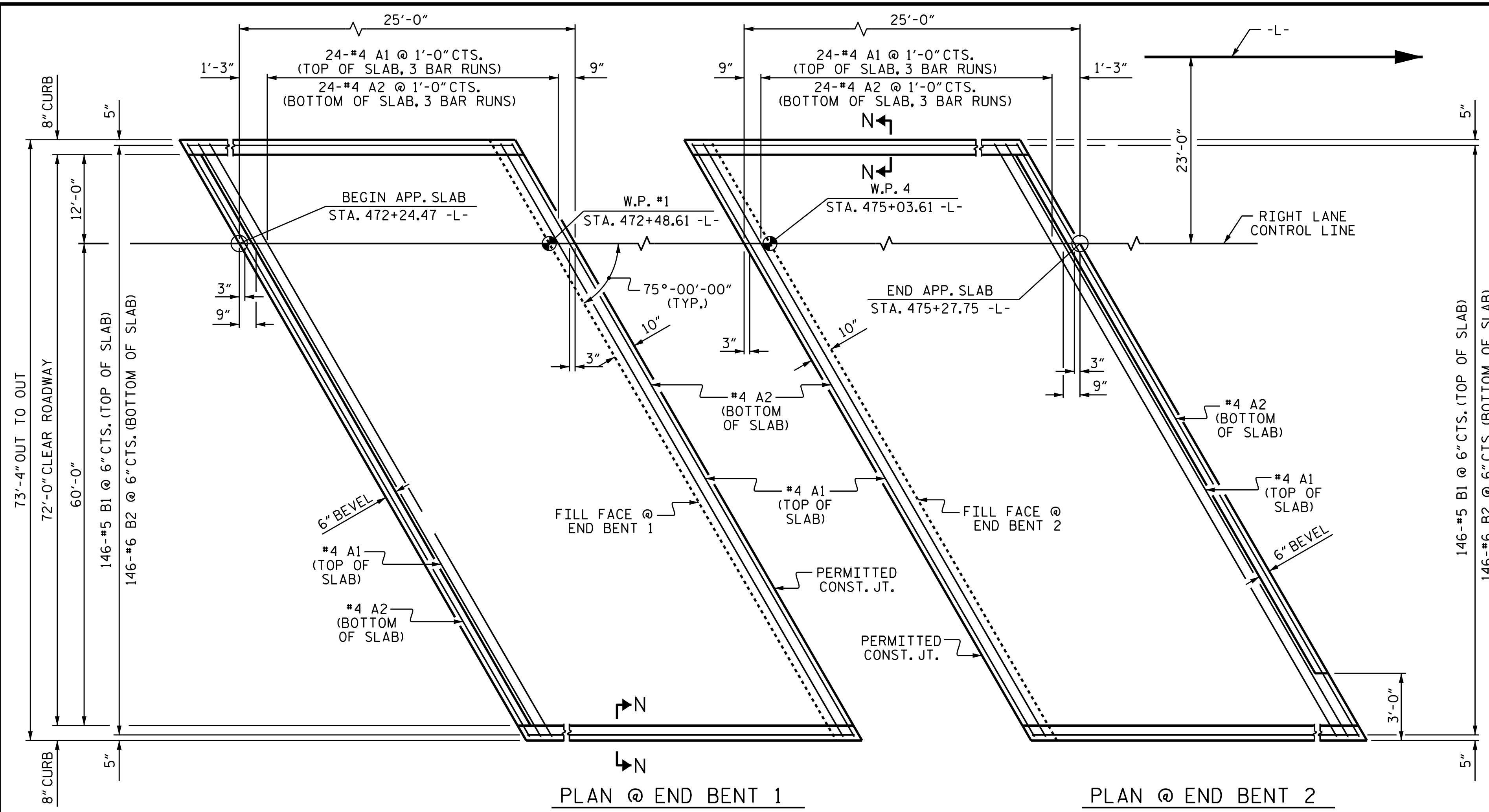

PLAN @ END BENT 1
 PLAN @ END BENT 2
 DIMENSIONS SHOWN ARE TYPICAL FOR BOTH APPROACH SLABS

NOTES

THE APPROACH SLAB MAY BE CAST MONOLITHICALLY WITH THE END BENT DIAPHRAGM AND THE END SECTION OF THE BRIDGE DECK NEAR THE INTEGRAL END BENT.

FOR REINFORCED BRIDGE APPROACH FILL FABRIC WALL INCLUDING GEOTEXTILE, IMPERMEABLE GEOMEMBRANE, 4" Ø DRAINAGE PIPE, #78M STONE, WELDED WIRE FORM, AND SELECT MATERIAL, SEE ROADWAY PLANS.

AREA BETWEEN THE WINGWALL AND APPROACH SLAB SHALL BE GRADED TO DRAIN THE WATER AWAY FROM THE FILL FACE OF THE BRIDGE AND SHALL BE PAVED. SEE ROADWAY PLANS.

THE JOINT OPENING AT THE APPROACH SLAB/DECK INTERFACE SHALL BE SAWED NO MORE THAN 12 HOURS AFTER THE APPROACH SLAB IS CAST. THE JOINT SHALL BE CLEANED OF ALL DEBRIS BEFORE THE SEALANT IS APPLIED. THE JOINT SEALER MATERIAL SHALL CONFORM TO THE REQUIREMENTS OF SECTION 1028-3 OF THE STANDARD SPECIFICATIONS.

BILL OF MATERIAL					
FOR ONE APPROACH SLAB (2 REQ'D)					
BAR	NO.	SIZE	TYPE	LENGTH	WEIGHT
* A1	78	#4	STR	26'-6"	1381
A2	78	#4	STR	26'-4"	1372
* B1	146	#5	STR	24'-2"	3680
B2	146	#6	STR	24'-7"	5391
REINFORCING STEEL					6763 LBS.
* EPOXY COATED REINFORCING STEEL					5061 LBS.
CLASS AA CONCRETE					79.1 C. Y.

SPLICE LENGTH		
BAR SIZE	EPOXY COATED	UNCOATED
#4	2'-0"	1'-9"
#5	2'-6"	2'-2"
#6	3'-10"	2'-7"

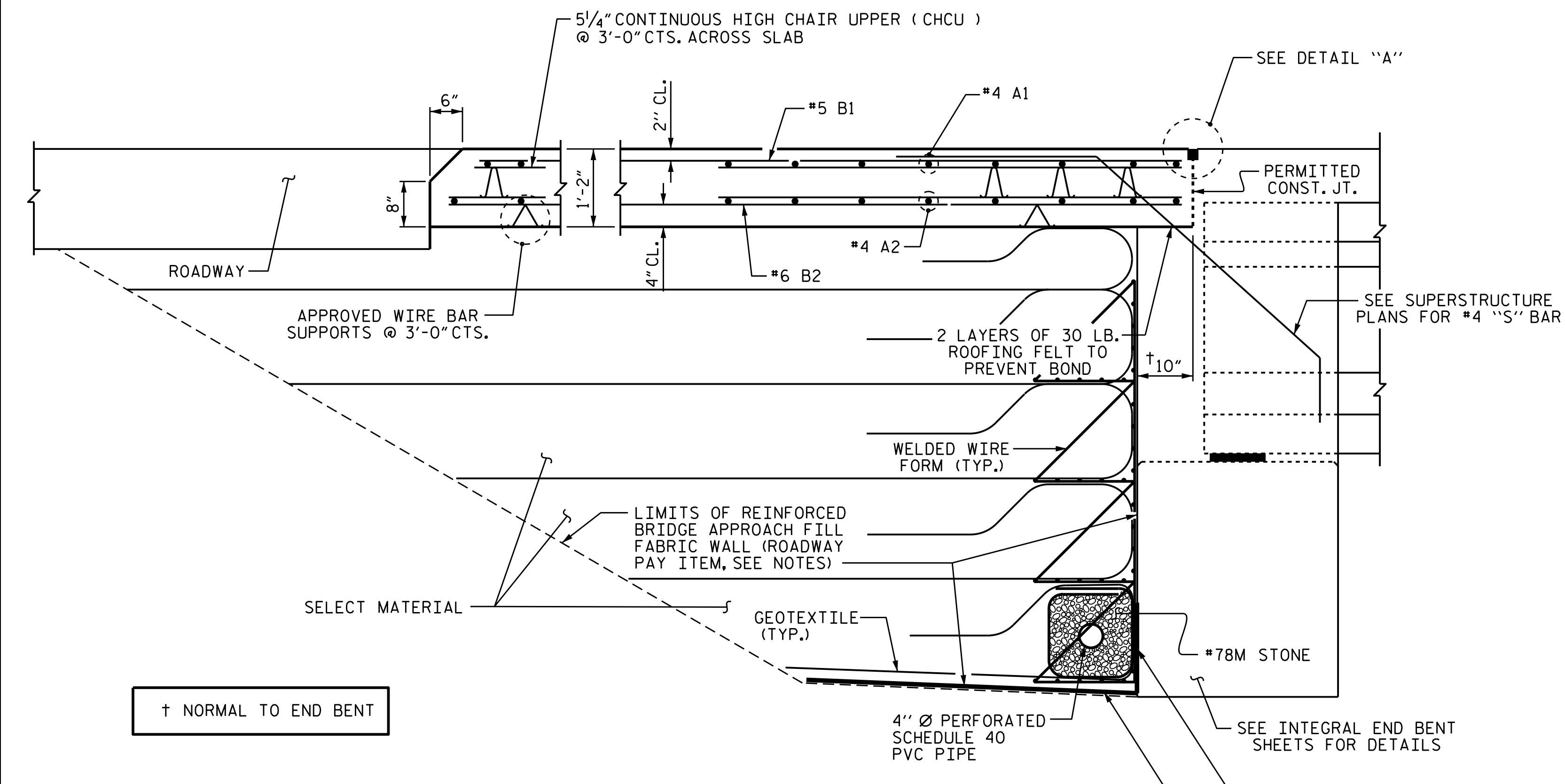

SECTION THRU SLAB

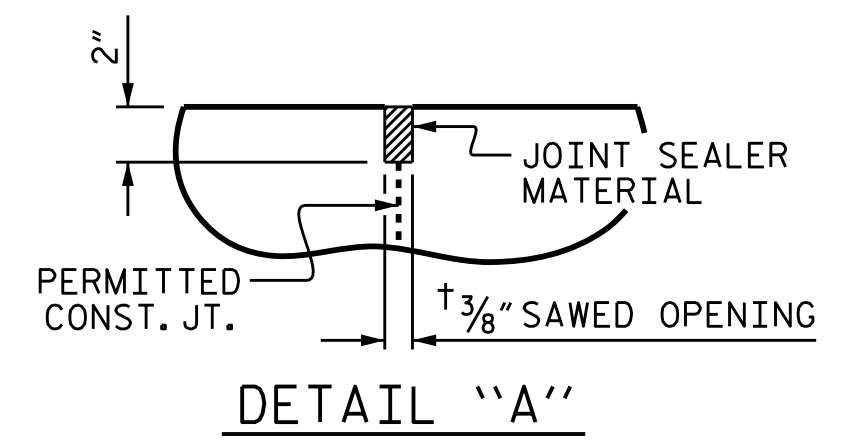

DETAIL "A"

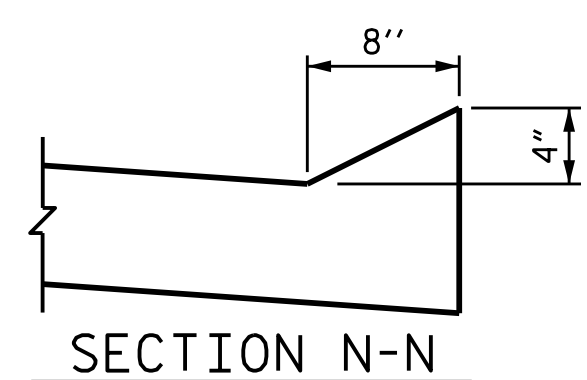
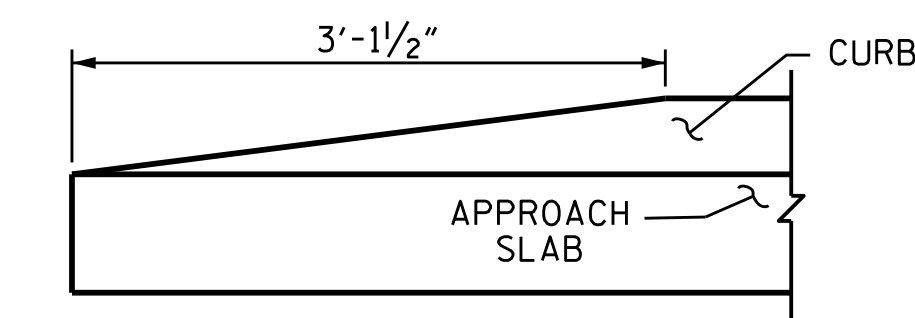

SECTION N-N

PROJECT NO. U-2579C
 FORSYTH COUNTY
 STATION: 473+70.00 -L-

SHEET 1 OF 2

STATE OF NORTH CAROLINA
 DEPARTMENT OF TRANSPORTATION
 RALEIGH
 STANDARD
 BRIDGE APPROACH SLAB
 FOR INTEGRAL ABUTMENT
 (RIGHT LANE)

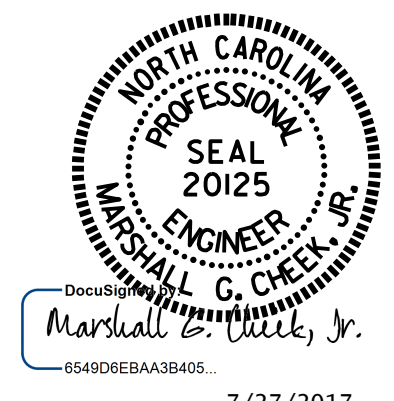

ASSEMBLED BY :	H. T. BARBOUR	DATE :	4-19-17
CHECKED BY :	T. L. AVERETTE	DATE :	4-20-17
DRAWN BY :	TLA	REV. 10/1/11	MAA/GM
CHECKED BY :	GM	REV. 12/21/11	MAA/GM
		REV. 6/13	MAA/GM

DOCUMENT NOT CONSIDERED FINAL UNLESS ALL SIGNATURES COMPLETED

REVISIONS						SHEET NO.
NO.	BY:	DATE:	NO.	BY:	DATE:	S4-32
1			3			TOTAL SHEETS 33
2			4			

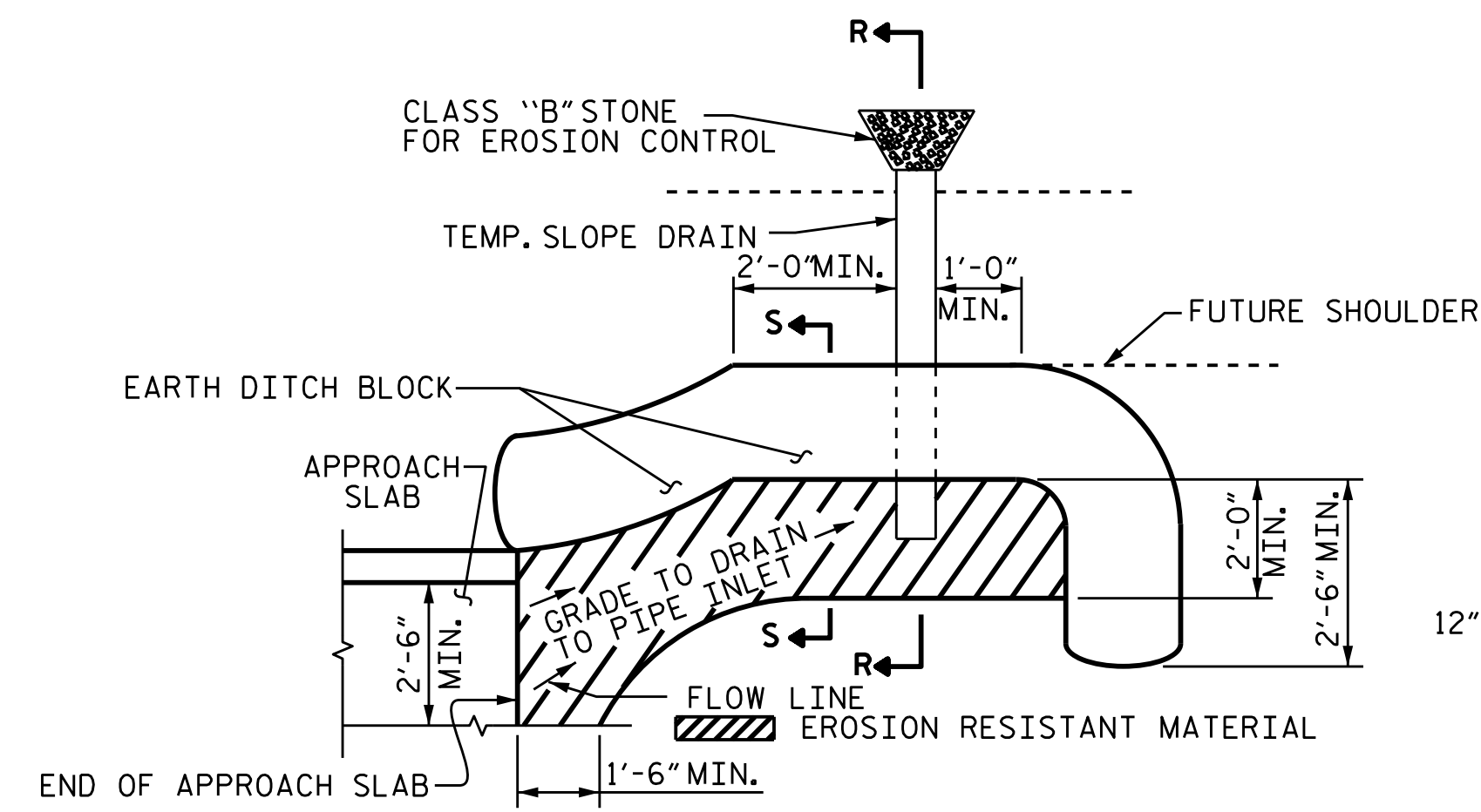

NOTE: IMMEDIATELY AFTER THE CONSTRUCTION OF THE APPROACH SLAB, THE CONTRACTOR SHALL PROVIDE TEMPORARY BERM AND SLOPE DRAIN. CONTRACTOR SHALL GRADE TO PIPE INLET AND PROVIDE EROSION RESISTANT MATERIAL AS SHOWN. THE EROSION RESISTANT MATERIAL SHALL BE EITHER 1) ASPHALT PLANT MIX, TYPE 1 OR TYPE 2, MIN. 2" DEPTH, 2) EROSION CONTROL MAT, OR 3) CONCRETE, AS DIRECTED BY THE ENGINEER. THE SLOPE DRAIN SHALL CONSIST OF A NON-PERFORATED TEMPORARY DRAINAGE PIPE, 12 INCHES IN DIAMETER.

PLAN VIEW

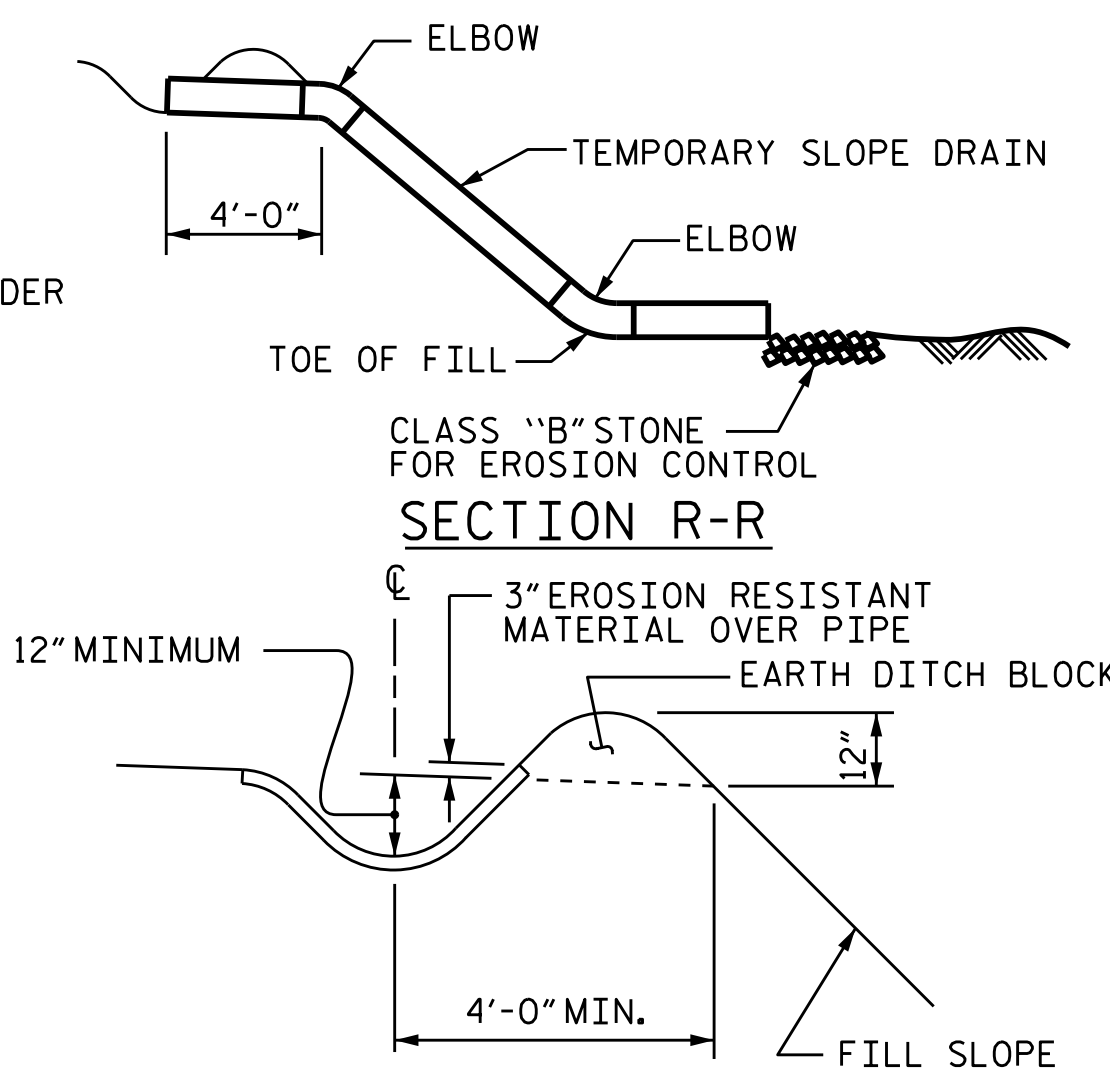

SECTION S-S

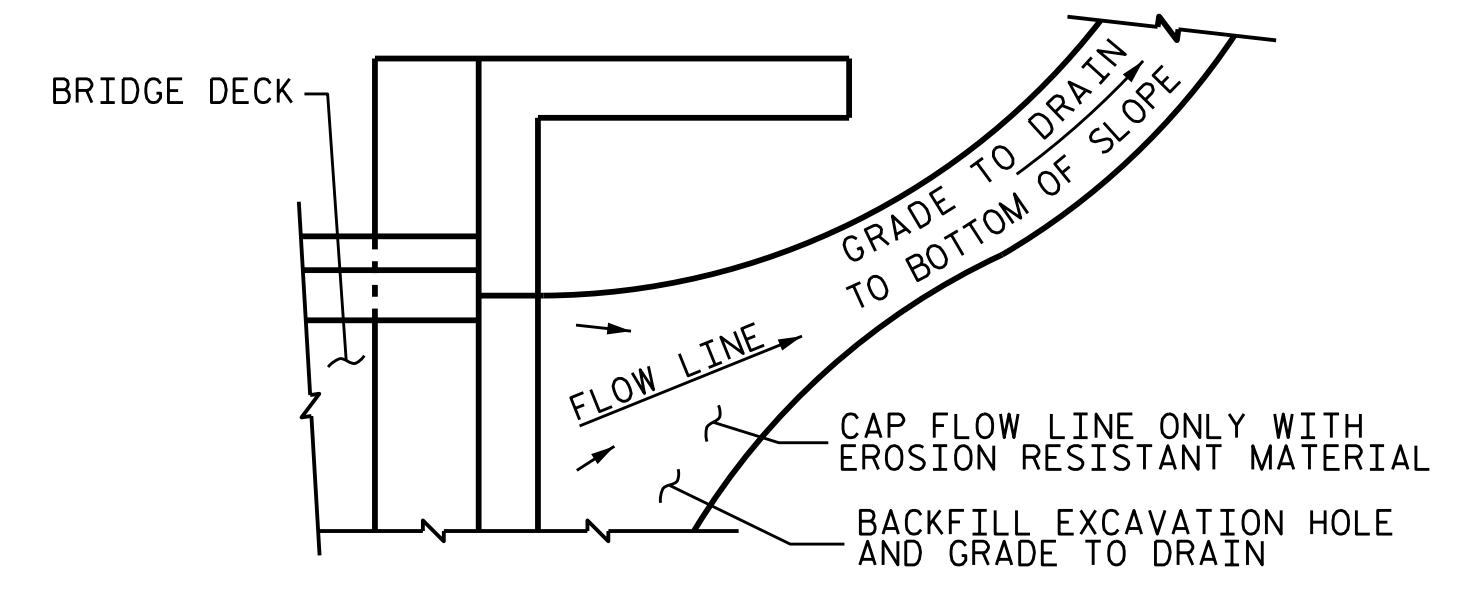

NOTE: IF THE APPROACH SLAB IS NOT CONSTRUCTED IMMEDIATELY AFTER THE BACKFILLING OF THE END BENT EXCAVATION, GRADE TO DRAIN TO THE BOTTOM OF THE SLOPE AND PROVIDE EROSION RESISTANT MATERIAL, SUCH AS FIBERGLASS ROVING OR AS DIRECTED BY THE ENGINEER TO PREVENT SOIL EROSION AND TO PROTECT THE AREA ADJACENT TO THE STRUCTURE. THE CONTRACTOR WILL BE REQUIRED TO REMOVE THESE MATERIALS PRIOR TO CONSTRUCTION OF THE APPROACH SLAB.

TEMPORARY DRAINAGE DETAIL

TEMPORARY BERM AND SLOPE DRAIN DETAILS
(TO BE USED WHEN SHOULDER BERM GUTTER IS REQUIRED)

PROJECT NO. U-2579C
FORSYTH COUNTY
STATION: 473+70.00 -L-

SHEET 2 OF 2

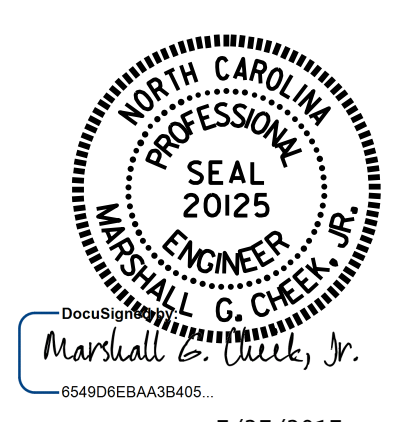

STATE OF NORTH CAROLINA
DEPARTMENT OF TRANSPORTATION
RALEIGH
STANDARD
BRIDGE APPROACH SLAB
FOR INTEGRAL ABUTMENT
DETAILS
(RIGHT LANE)

DRAWN BY : H. T. BARBOUR DATE : 4-19-17
CHECKED BY : T. L. AVERETTE DATE : 4-20-17

DOCUMENT NOT CONSIDERED
FINAL UNLESS ALL
SIGNATURES COMPLETED

REVISIONS						SHEET NO.	
NO.	BY:	DATE:	NO.	BY:	DATE:	TOTAL SHEETS	
1			3			4	33
2			4				