

CONFIDENTIAL AND PROPRIETARY PROPERTY OF  
**EBDG - NC, PLLC**  
 MAY NOT BE USED FOR CONSTRUCTION OR PROVIDED TO  
 ANY THIRD PARTIES WITHOUT PRIOR WRITTEN CONSENT.  
 © 2017 ELLIOTT BAY DESIGN GROUP.

**GENERAL NOTES (CONT)**

10. STRAINERS SHALL PROTECT REDUCING STATIONS AND OTHER ITEMS OF EQUIPMENT SUPPLIED WITH COMPRESSED AIR.
11. FIRE SUPPRESSION SYSTEM SHALL BE SIZED TO INCLUDE THE VOLUME OF FREE AIR CONTAINED IN THE AIR RECEIVERS.
12. REDUCING STATION RELIEFS SHALL BE SET TO 10% ABOVE REDUCING STATION OUTLET PRESSURE. ROUTE RELIEF LINES TO THE BILGE.
13. WHERE PIPES PENETRATE TANK BOUNDARIES, BULKHEADS, OR DECKS HEAVY WEIGHT SPOOL PIECES OR AN ALTERNATE APPROVED PENETRATION FITTING SHALL BE USED. SEE DETAIL 1-6A.
14. LOW POINTS SHALL BE FITTED WITH DIRT LEGS AND DRAIN VALVES.
15. SERVICE AIR STATIONS REGULATORS SHALL BE EQUIPPED WITH PRESSURE GAUGE AND FILTER, CAPABLE OF UP TO 14 SCFM, ADJUSTABLE FROM 5 TO 125 PSIG.
16. REDUCING STATIONS SHALL INCLUDE A RELIEVING PRESSURE-REDUCING VALVE PRECEDED BY A WHY STRAINER, ISOLATION VALVES, AND A GLOBE BYPASS VALVE.
17. INTEGRATE AIR SUPPLY PRESSURE SENSORS WITH SHIP'S ALARM AND MONITORING SYSTEM. CONFIGURE FOR LOW PRESSURE ALARM. SEE REF 1.
18. COMPRESSORS SHALL BE SUPPLIED MOUNTED ON HORIZONTAL AIR RECEIVERS.

**REVISION HISTORY**

REV	ZONE	DESCRIPTION	DWN	DATE	APVD

**MATERIAL SCHEDULE**

SERVICE	SIZE	PIPE	TAKEDOWN JOINTS			VALVES		FITTINGS	FLEXIBLE CONNECTIONS
			MATERIAL	GASKETS	BOLTING	BODY	TRIM		
COMPRESSED AIR MAWP: 165 PSIG	ALL	CARBON STEEL ASTM A53 OR A106, GRADE B, SEAMLESS ANSI B36.10 SCH 80	UNION, GROUND JOINT CARBON STEEL ASTM A105, 3000# MSS-SP-83 SOCKET WELD	-	-	BALL: CARBON STEEL ASTM A105, SOCKET WELD OR THREADED  GATE, GLOBE, CHECK: CARBON STEEL ASTM A105 SOCKET WELD OR THREADED, ANSI B16.34	BALL: STAINLESS STEEL BALL & STEM, PTFE SEATS & SEALS  GATE, GLOBE, CHECK: STAINLESS STEEL	CARBON STEEL ASTM A105, 3000# ANSI B16.11 SOCKET WELD	SEE NOTE 9

**EQUIPMENT LIST**

QTY.	SERVICE	TYPE	MODEL	CAPACITY	DRIVE	REMARKS
2	SHIP SERVICE COMPRESSOR	2 STAGE RECIPROCATING 828 RPM	-	17 SCFM @ 175 PSI	BELT DRIVE 208 VAC/3φ/60 Hz 5 HP TEFC MOTOR	NOTE 18
2	SHIP SERVICE RECEIVER	HORIZONTAL AIR RECEIVER	-	80 GAL SEE NOTE 11	-	ASME RATED TO 200 PSIG NOTES 8 & 18
2	SHIP'S HORN	AIR HORN	-	29 CFM 100 PSIG	-	WITH COMBINATION MANUAL/SOLENOID VALVE
1	AIR FILTER	COALESCING	-	5 CFM 80 PSIG	-	5 MICRON W/ OIL REMOVAL
1	AIR DRYER	DESICCANT CARTRIDGE	-	5 CFM 80 PSIG	-	-

**SYMBOLS LIST**

	PIPE
	BHD PENETRATION
	REDUCER
	BALL VALVE
	GLOBE VALVE
	LIFT CHECK VALVE
	SAFETY RELIEF VALVE
	STOP CHECK VALVE
	COMBINATION MANUAL/SOLENOID VALVE
	PRESSURE REGULATING VALVE
	FLEXIBLE CONNECTION
	STRAINER, WYE TYPE
	AIR COMPRESSOR
	QUICK DISCONNECT
	PRESSURE SWITCH
	PRESSURE TRANSDUCER
	PRESSURE GAUGE, LOCAL READING
	AIR FILTER
	AIR DRYER, CARTRIDGE TYPE
	AIR REGULATOR W/PRESSURE GAUGE

**GENERAL NOTES**

1. VESSEL TO BE CONSTRUCTED IN ACCORDANCE WITH 46 CFR SUBCHAPTER H REGULATIONS.
2. THIS DRAWING IS DIAGRAMMATIC AND DOES NOT REPRESENT A COMPLETE DETAILED DESIGN. EQUIPMENT LAYOUT IN A GIVEN AREA IS APPROXIMATE. THE CONTRACTOR SHALL DEVELOP A DETAILED DESIGN THAT PROVIDES A FULLY FUNCTIONAL ARRANGEMENT SUITABLE FOR INSTALLATION, TAKING INTO ACCOUNT ALL NECESSARY SYSTEM INTERFACES AND INTERFERENCES. DIMENSIONS SHALL BE VERIFIED FROM THE SHIP AND MANUFACTURER'S CERTIFIED DRAWINGS AS APPROPRIATE.
3. PIPING SHALL BE RUN AS DIRECTLY AS PRACTICABLE WITH A MINIMUM NUMBER OF BENDS AND FITTINGS. PIPE SPOOLS SHALL BE SIZED AND ARRANGED TO PROVIDE FOR REMOVAL, INSPECTION, SERVICING, AND REPLACEMENT OF PIPING, VALVES, FITTINGS, AND EQUIPMENT WITHOUT CUTTING STRUCTURE OR PIPING.
4. PIPING SHALL BE ADEQUATELY SUPPORTED BY HANGERS IN ACCORDANCE WITH ASTM F708. HANGERS SHALL BE ATTACHED TO THE PIPE WITH BOLTED CLAMPS AND WELDED TO BASIC SHIP STRUCTURE. HANGERS SHALL NOT BE WELDED DIRECTLY TO PIPES.
5. THE PIPING SYSTEM SHALL BE CLEANED, FLUSHED, FILLED AND HYDROSTATICALLY PRESSURE TESTED IN ACCORDANCE WITH USCG REQUIREMENTS. SEE REF 1.
6. AIR COMPRESSORS SHALL BE CONFIGURED FOR A LEAD/LAG OPERATION. THE LEAD COMPRESSOR SHALL START AT 130 PSI AND STOP AT 150 PSI. THE LAG COMPRESSOR SHALL START AT 100 PSI AND STOP AT 150 PSI.
7. THE SUPPLY AND DISCHARGE CONNECTIONS TO EACH AIR RECEIVER SHALL BE LOCATED AS HIGH AS PRACTICAL IN THE RECEIVER. SUPPLY AND DISCHARGE SHALL NOT BE THROUGH A COMMON CONNECTION, AND IN NO EVENT SHALL THE DISCHARGE CONNECTION BE AT THE BOTTOM OF THE RECEIVER.
8. AIR RECEIVERS SHALL BE DESIGNED, CERTIFIED AND STAMPED FOR 200 PSI WORKING PRESSURE IN ACCORDANCE WITH ASME & 46 CFR 54. RECEIVERS SHALL BE MOUNTED IN SUCH A WAY THAT UNDER THE MOST EXTREME TRIMMING CONDITIONS, THE DRAIN WILL SAY AT THE LOWEST POINT. ACCESS FOR CLEANING SHALL BE PROVIDED.
9. BURSTING PRESSURE OF FLEX CONNECTIONS SHALL BE AT LEAST 5 TIME THE WORKING PRESSURE OR 4 TIMES THE RELIEF VALVE SETTING.

**REFERENCES**

1. 16101-200-832-1 TECHNICAL SPECIFICATION
2. 16101-200-521-1 FIRE MAIN SYSTEM SCHEMATIC
3. 16101-200-529-1 BILGE AND BALLAST SCHEMATIC



**Elliott Bay Design Group**  
 North Carolina, PLLC

CLIENT: NORTH CAROLINA D.O.T.  
 RALEIGH, NORTH CAROLINA

PROJECT: NEW RIVER CLASS FERRY



SIZE	D	DWG NO.	16101-200-551-1	REV	-
SCALE	NTS	FILE NAME	16101-200-551-1-	SHEET	1 OF 2
DWN	LGB	MOD		APVD	LGB
		CKD	NJB	APVD DATE	7/21/17

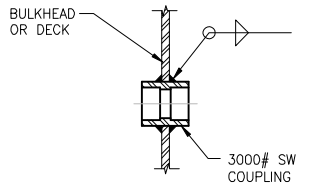

**DETAIL 1-6A**  
 TYP DECK/BHD PENETRATION  
 FOR SCH 80 STEEL PIPE 2" AND BELOW

7/21/2017 5:25:52 PM

CONFIDENTIAL AND PROPRIETARY PROPERTY OF  
**EBDG - NC, PLLC**  
 MAY NOT BE USED FOR CONSTRUCTION OR PROVIDED TO  
 ANY THIRD PARTIES WITHOUT PRIOR WRITTEN CONSENT.  
 © 2017 ELLIOTT BAY DESIGN GROUP.

6 5 4 3 2 1

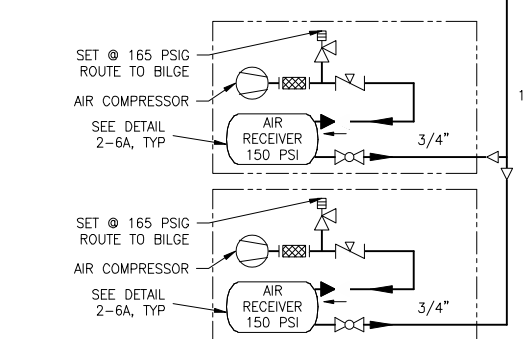
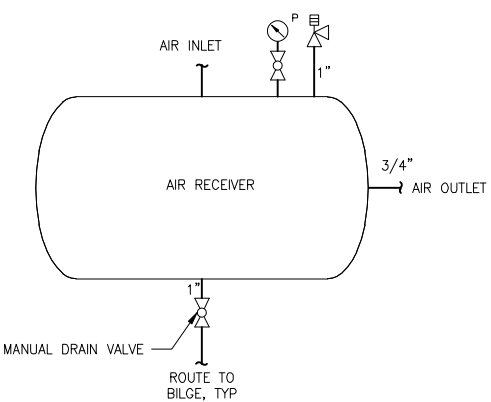
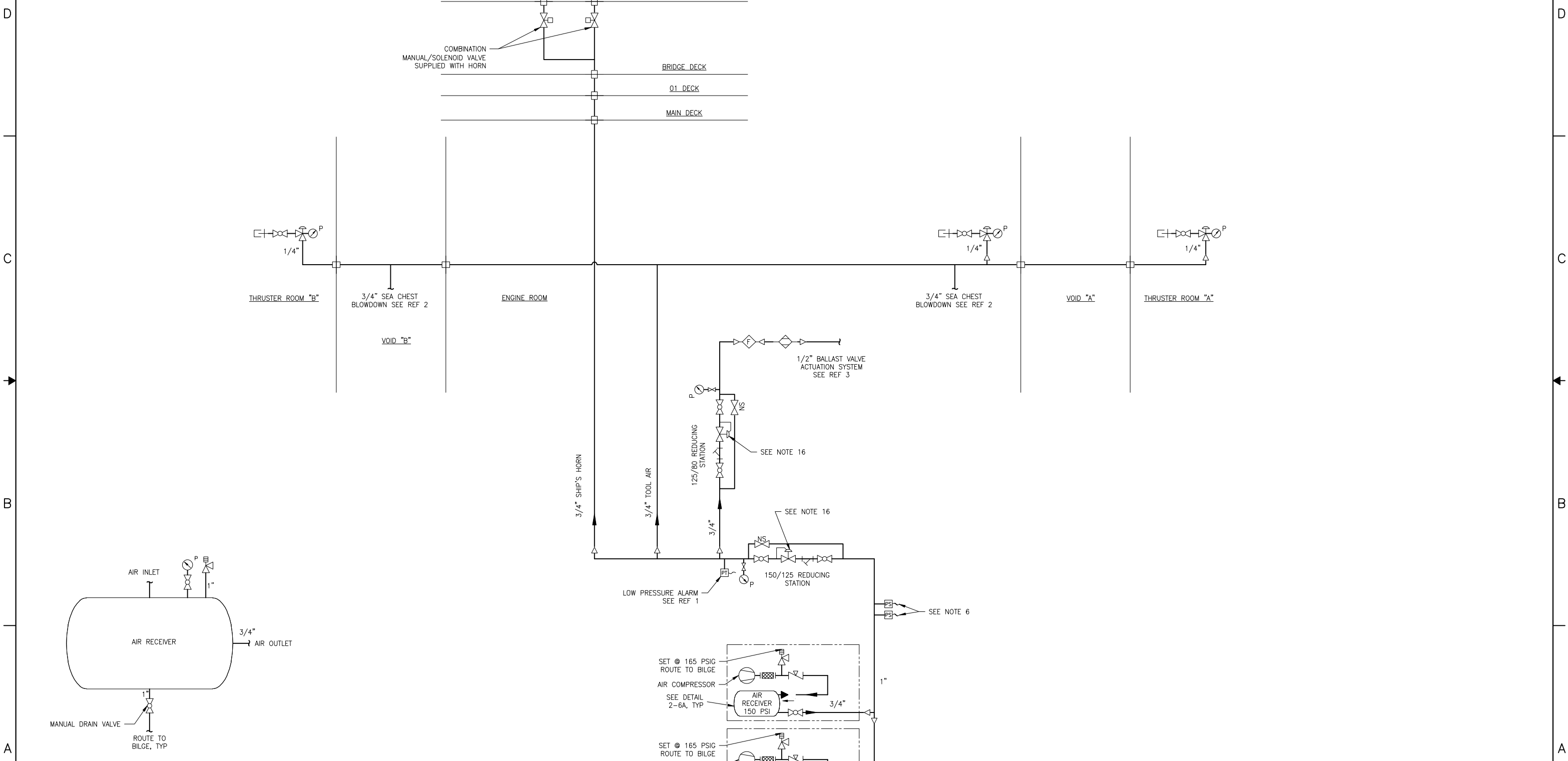

SIZE	D	DWG NO.	16101-200-551-1	REV	-
SCALE	NTS	FILE NAME	16101-200-551-1-	SHEET	2 OF 2

6 5 4 3 2 1

7/21/2017 5:25:57 PM