

**This electronic collection of documents is provided
for the convenience of the user
and is Not a Certified Document –**

**The documents contained herein were originally issued
and sealed by the individuals whose names and license
numbers appear on each page, on the dates appearing
with their signature on that page.**

**This file or an individual page
shall not be considered a certified document.**

T.I.P.: I-4729A

CONTRACT: C204039

STATE OF NORTH CAROLINA
DEPARTMENT OF TRANSPORTATION

PLAN PREPARED BY:
PROGRESSIVE
 DESIGN GROUP, INC.

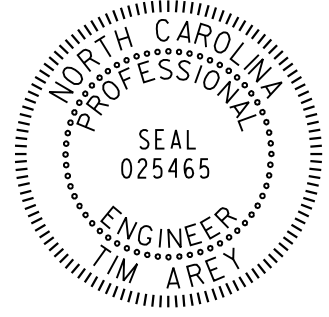
 ENGINEERS • CONSULTANTS

TIP NO. I-4729A	SHEET NO. PMP-1
APPROVED: <i>Tim Arey</i>	
DATE: 8/15/2017	
SEAL	
	
DOCUMENT NOT CONSIDERED FINAL UNLESS ALL SIGNATURES COMPLETED	

PAVEMENT MARKING PLAN
POLK COUNTY

LOCATION: I-26/US 74 INTERCHANGE IMPROVEMENTS

ROADWAY STANDARD DRAWING

THE FOLLOWING ROADWAY STANDARDS AS APPEAR IN "ROADWAY STANDARD DRAWINGS" - PROJECT SERVICES UNIT - N.C. DEPARTMENT OF TRANSPORTATION - RALEIGH, N.C., DATED JULY 2012 ARE APPLICABLE TO THIS PROJECT AND BY REFERENCE HEREBY ARE CONSIDERED A PART OF THESE PLANS:

STD. NO.	TITLE
1205.01	PAVEMENT MARKINGS - LINE TYPES AND OFFSETS
1205.02	PAVEMENT MARKINGS - 2 LANE AND MULTILANE ROADWAYS
1205.03	PAVEMENT MARKINGS - EXIT AND ENTRANCE RAMP
1205.04	PAVEMENT MARKINGS - INTERSECTIONS
1205.08	PAVEMENT MARKINGS - SYMBOLS AND WORD MESSAGES
1205.09	PAVEMENT MARKINGS - PAINTED ISLANDS
1205.12	PAVEMENT MARKINGS - BRIDGES
1205.13	PAVEMENT MARKINGS - LANE REDUCTIONS
1250.01	RAISED PAVEMENT MARKERS - INSTALLATION SPACING
1250.01	RAISED PAVEMENT MARKERS - INSTALLATION SPACING
1251.01	RAISED PAVEMENT MARKERS - PERMANENT AND TEMPORARY
1261.01	GUARDRAIL AND BARRIER DELINEATORS - INSTALLATION SPACING
1261.02	GUARDRAIL AND BARRIER DELINEATORS - TYPES AND MOUNTING
1262.01	GUARDRAIL END DELINEATION
1267.01	FLEXIBLE DELINEATORS - INSTALLATION
1267.02	FLEXIBLE DELINEATORS - SPACING TABLES
1267.03	FLEXIBLE DELINEATORS - INTERCHANGE PLACEMENT

GENERAL NOTES

THE FOLLOWING GENERAL NOTES APPLY AT ALL TIMES FOR THE DURATION OF THE CONSTRUCTION PROJECT, EXCEPT WHEN OTHERWISE NOTED IN THE PLAN, OR DIRECTED BY THE ENGINEER.

- A) INSTALL PAVEMENT MARKINGS AND PAVEMENT MARKERS ON THE FINAL SURFACE AS FOLLOWS:

ROAD NAME	MARKING	MARKER
ALL	THERMOPLASTIC	SNOWFLOWABLE
BRIDGES	THERMOPLASTIC	PERMANENT RAISED

- B) TIE PROPOSED PAVEMENT MARKING LINES TO EXISTING PAVEMENT MARKING LINES.
- C) REMOVE/REPLACE ANY CONFLICTING/DAMAGED PAVEMENT MARKINGS AND MARKERS.
- D) REMOVE ALL RESIDUE AND SURFACE LAITANCE BY ACCEPTABLE METHODS ON CONCRETE BRIDGE DECKS PRIOR TO PLACING PAVEMENT MARKING MATERIAL.
- E) UNLESS OTHERWISE SPECIFIED, HEATED-IN-PLACE THERMOPLASTIC MAY BE USED IN LIEU OF EXTRUDED THERMOPLASTIC FOR STOP BARS, SYMBOLS, CHARACTERS AND DIAGONALS. IF HEATED-IN-PLACE IS USED, IT SHALL BE PAID FOR USING THE EXTRUDED THERMOPLASTIC PAY ITEM.

PAVEMENT MARKING SCHEDULE

- THERMOPLASTIC (6", 90 MILS)
 T6 WHITE EDGELINE
 T7 YELLOW EDGELINE
- THERMOPLASTIC (6", 120 MILS)
 TJ 10 FT. WHITE SKIP
 TK 3 FT. - 9 FT./ST WHITE MINISKIP
- THERMOPLASTIC (12", 90 MILS)
 TS WHITE GORELINE
 TV YELLOW DIAGONAL
- THERMOPLASTIC PAVEMENT MARKING SYMBOLS (90 MILS)
 UP MERGE ARROW

NOTE:
4" AND 8" THERMOPLASTIC PAVEMENT MARKING LINES (90 MILS) ARE USED IN THE MILL AND FILL AREAS ON NC 108 BETWEEN US 74 AND THE COLUMBUS TOWN LIMIT. THIS AREA IS NOT INCLUDED ON THE PAVEMENT MARKING PLANS AND THEREFORE THESE ITEMS ARE NOT INCLUDED ON THE PAVEMENT MARKING SCHEDULE.

INDEX

SHEET NO.	DESCRIPTION
PMP-1	PAVEMENT MARKING PLAN TITLE SHEET
PMP-2 THRU PMP-8	PAVEMENT MARKING DETAIL SHEETS

FINAL PAVEMENT MARKINGS

DOCUMENT NOT CONSIDERED FINAL
 UNLESS ALL SIGNATURES COMPLETED

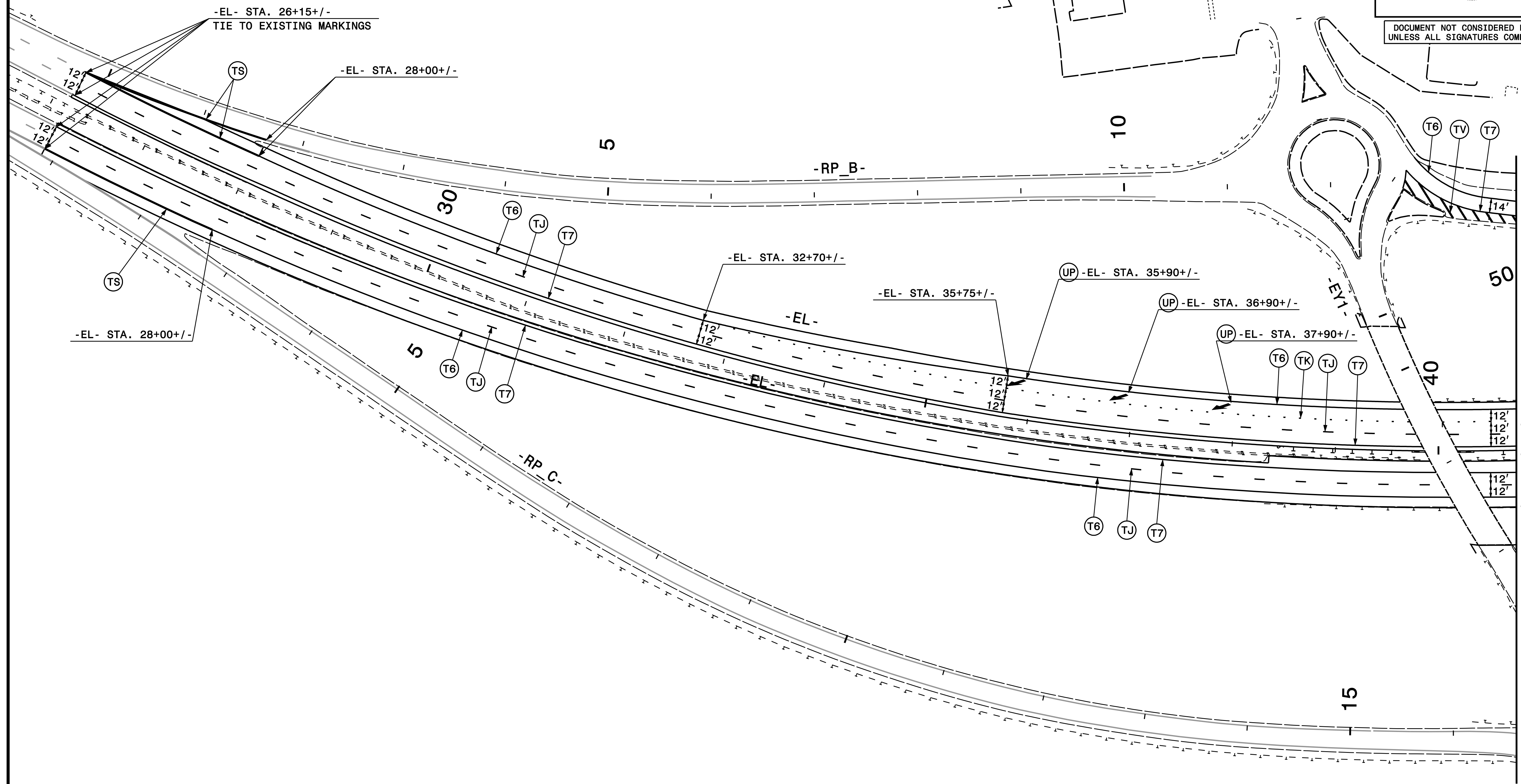

FINAL PAVEMENT MARKINGS

DOCUMENT NOT CONSIDERED FINAL
 UNLESS ALL SIGNATURES COMPLETED

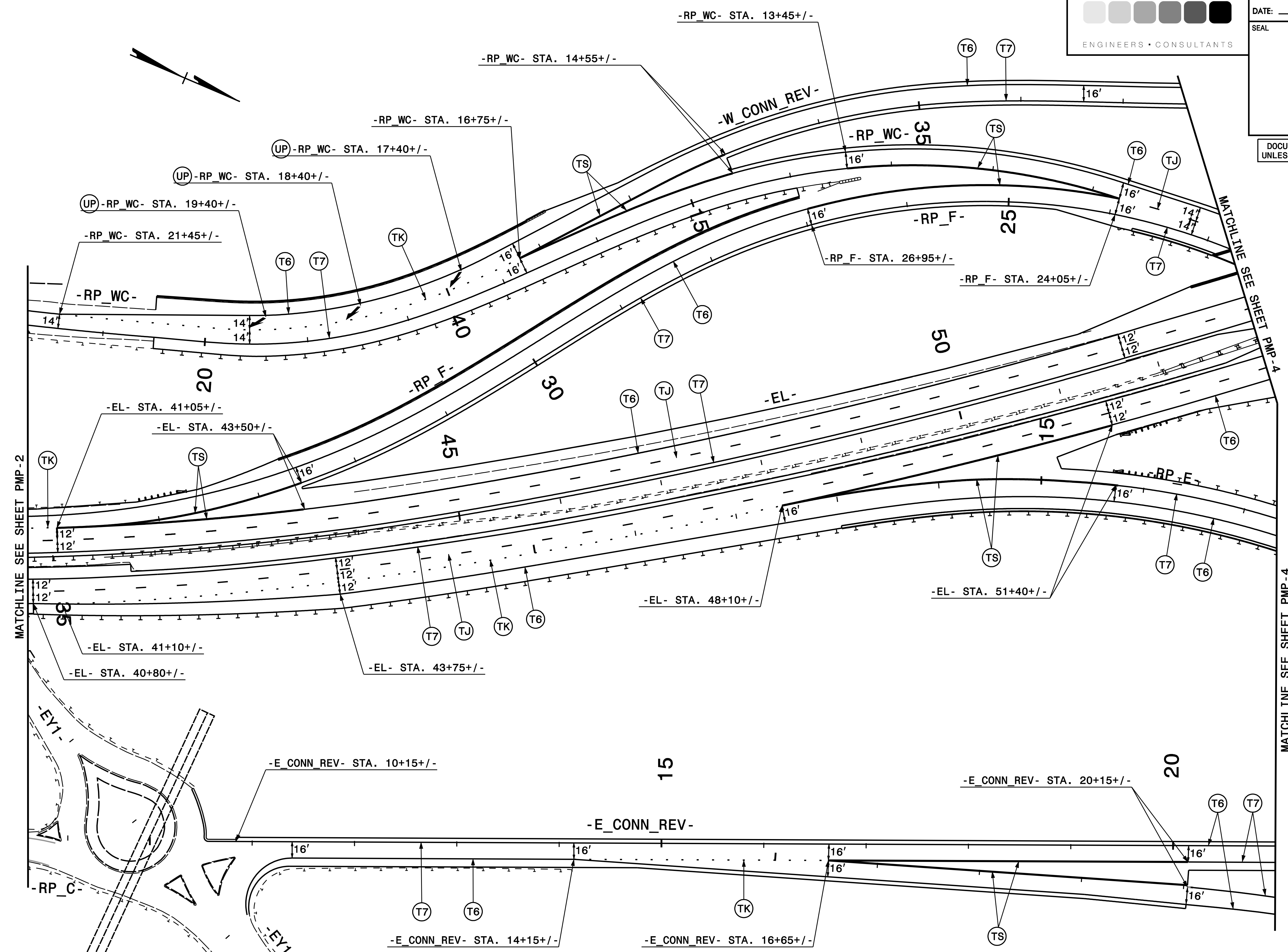

FINAL PAVEMENT MARKINGS

DOCUMENT NOT CONSIDERED FINAL
 UNLESS ALL SIGNATURES COMPLETED

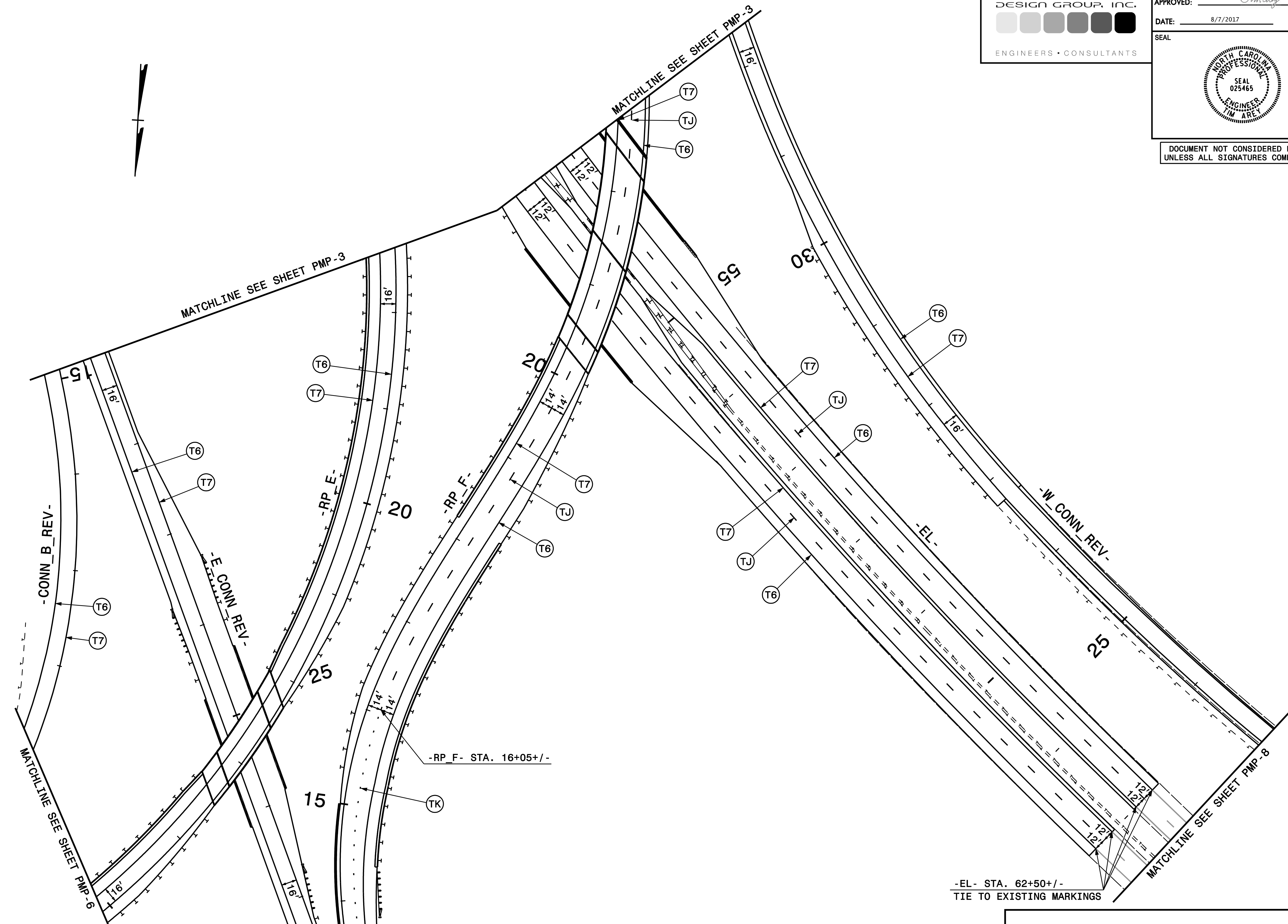

FINAL PAVEMENT MARKINGS

DOCUMENT NOT CONSIDERED FINAL
 UNLESS ALL SIGNATURES COMPLETED

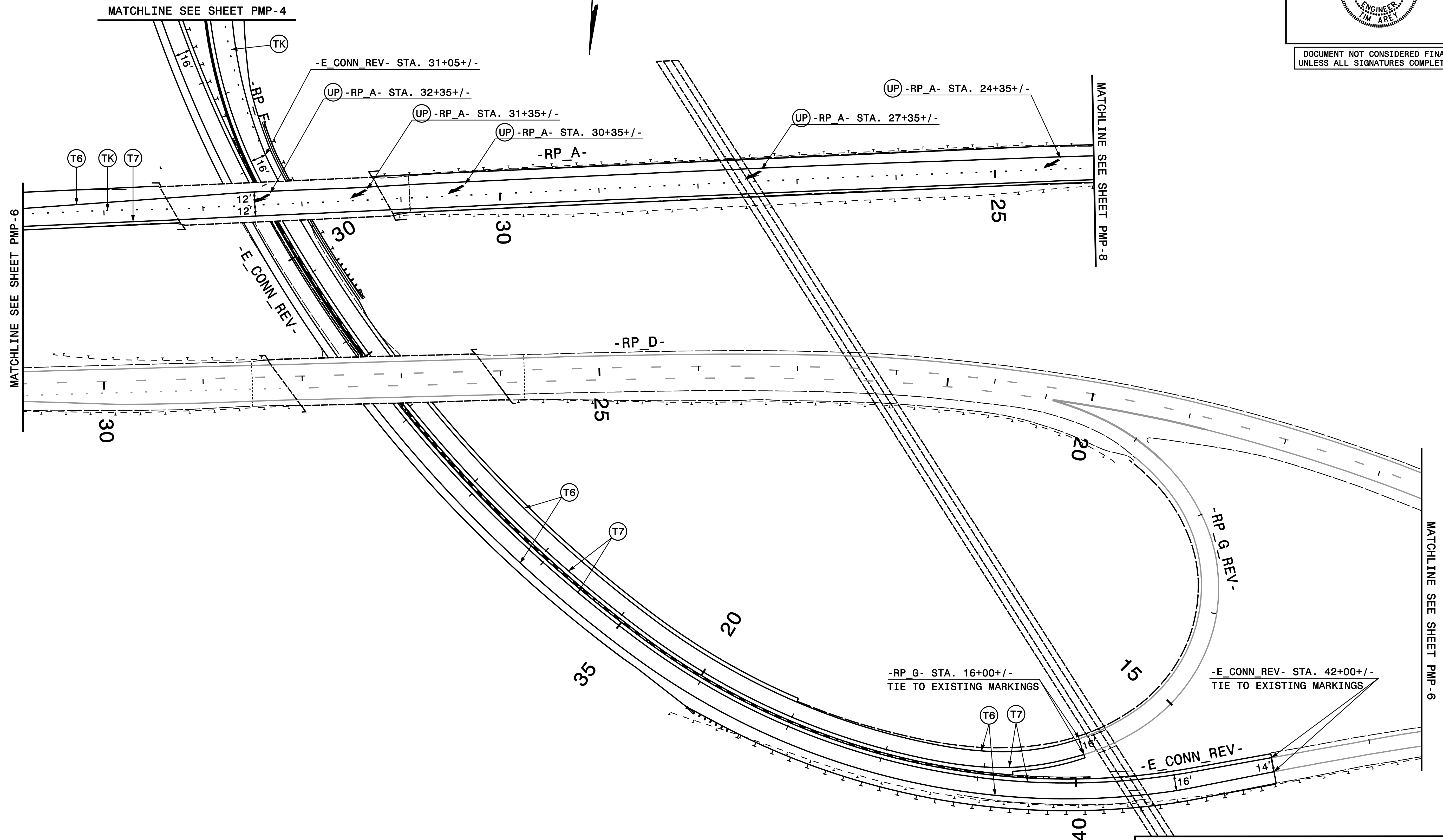

FINAL PAVEMENT MARKINGS

DOCUMENT NOT CONSIDERED FINAL
 UNLESS ALL SIGNATURES COMPLETED

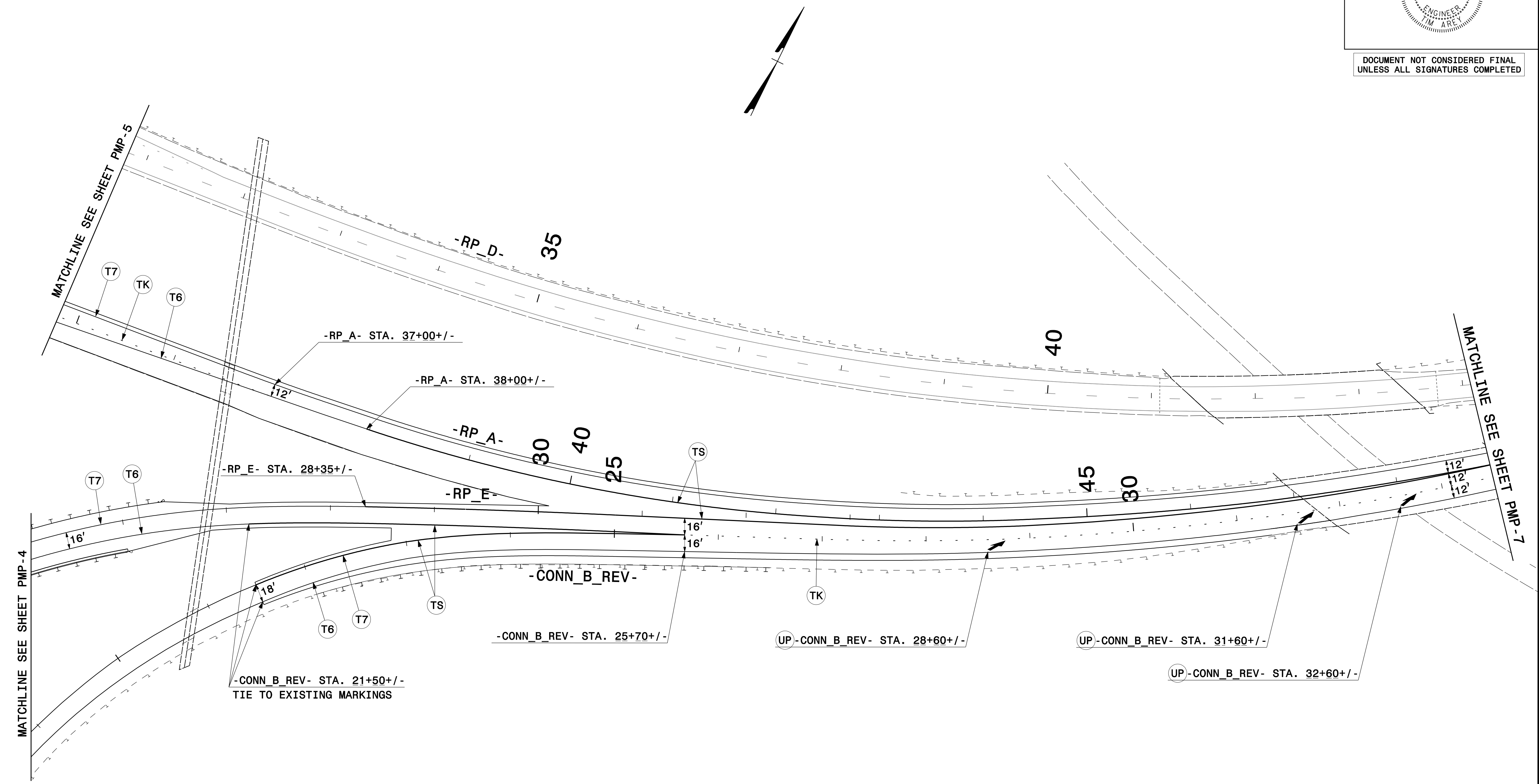

FINAL PAVEMENT MARKINGS

DOCUMENT NOT CONSIDERED FINAL
 UNLESS ALL SIGNATURES COMPLETED

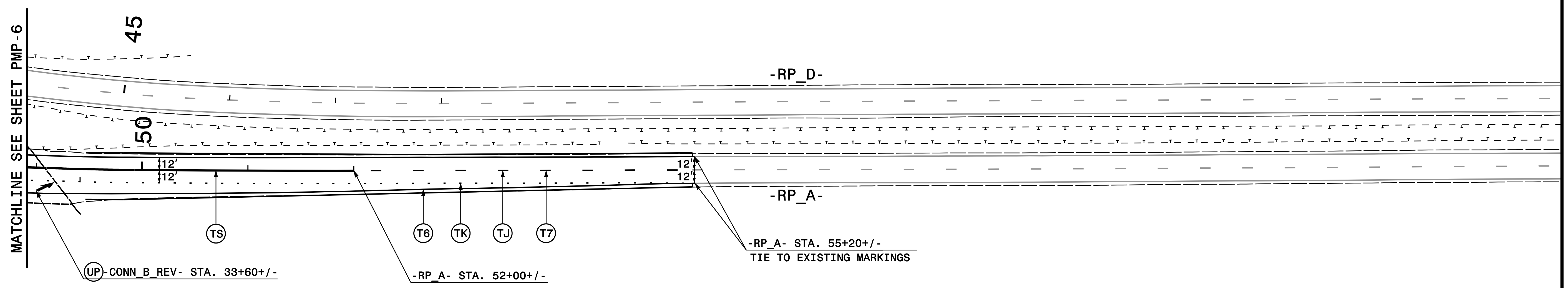
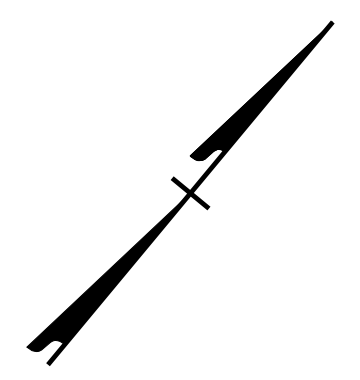

FINAL PAVEMENT MARKINGS

DOCUMENT NOT CONSIDERED FINAL
 UNLESS ALL SIGNATURES COMPLETED

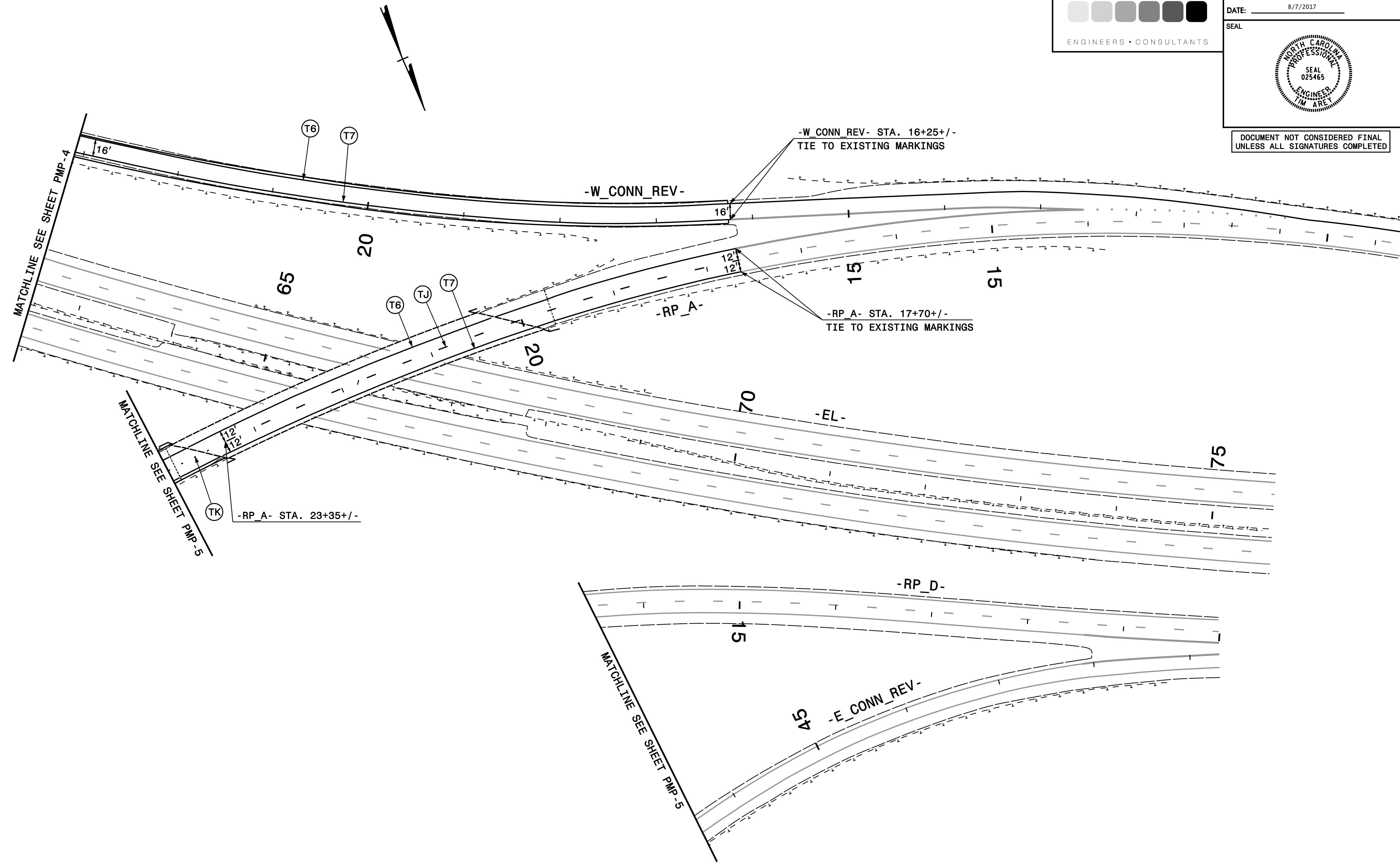

FINAL PAVEMENT MARKINGS