

PROJECT REFERENCE NO. 1-4729A	SHEET NO. STRM 04
RW SHEET NO.	
ROADWAY DESIGN ENGINEER	HYDRAULICS ENGINEER
	
8/14/2017	
DOCUMENT NOT CONSIDERED FINAL UNLESS ALL SIGNATURES COMPLETED	

STRUCTURE LOCATIONS				
STR. TYPE	STATION	OFFSET	NORTHING	EASTING
ROCK CROSS VANE	11+01.6	0	561,040.9327	1,042,709.2159
DOUBLE LOG VANE	13+22.2	0	560,821.0519	1,042,713.5327
DOUBLE LOG VANE	15+07.8	0	560,654.7900	1,042,789.5108
ROCK CROSS VANE	17+00.3	0	560,466.9352	1,042,806.2202

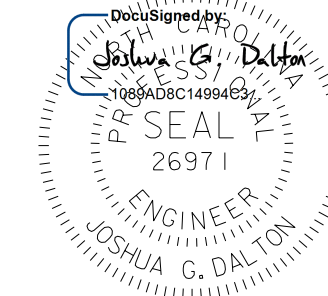
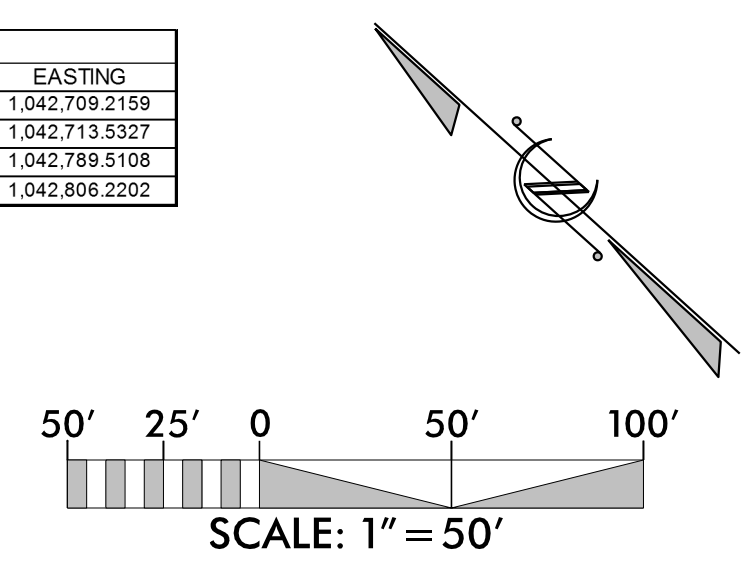

SEE PSH STRM 05 FOR CHANNEL PROFILE

REVISIONS

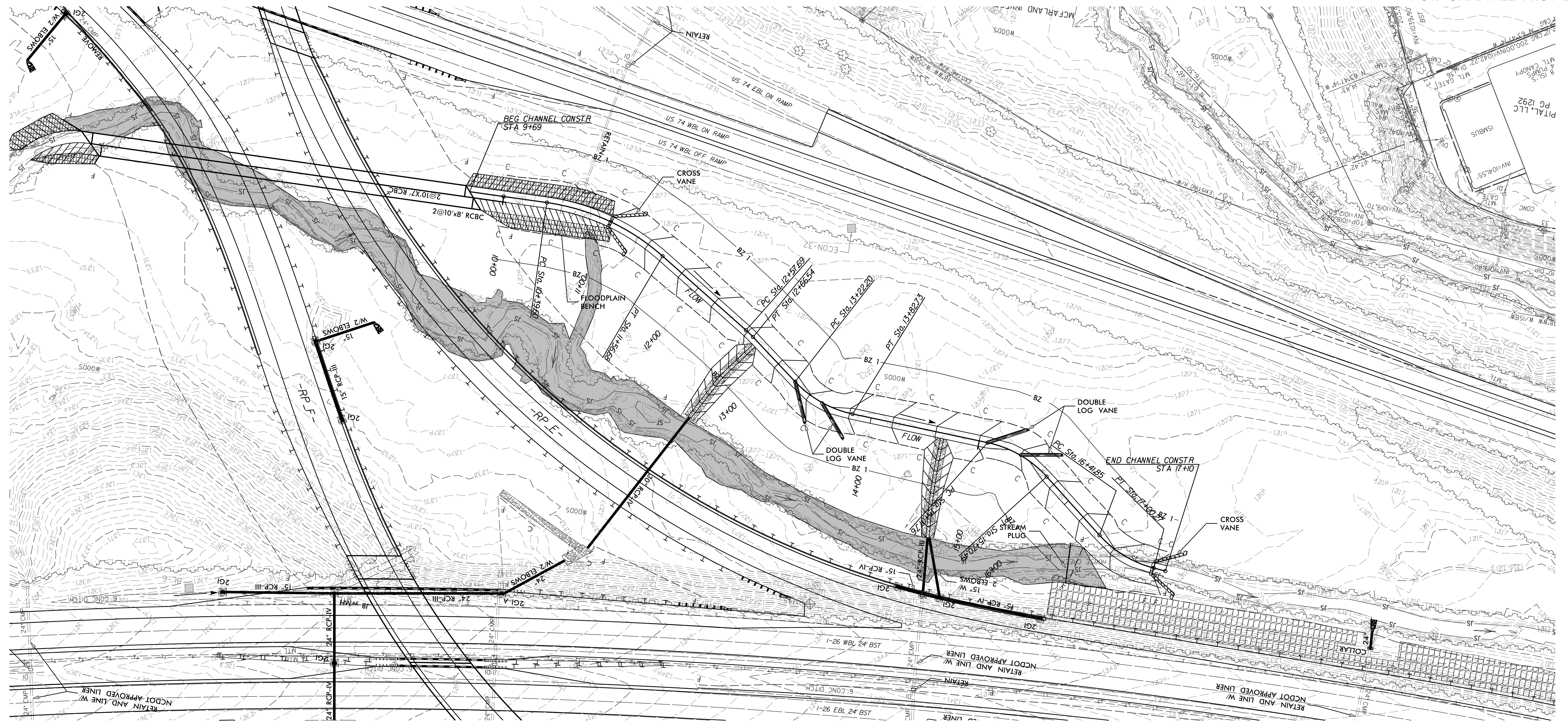

 FILL EXISTING CHANNEL