

NOTE: SEE STD.DWG. 846.01 FOR  
2'-6" CURB AND GUTTER  
INFORMATION.

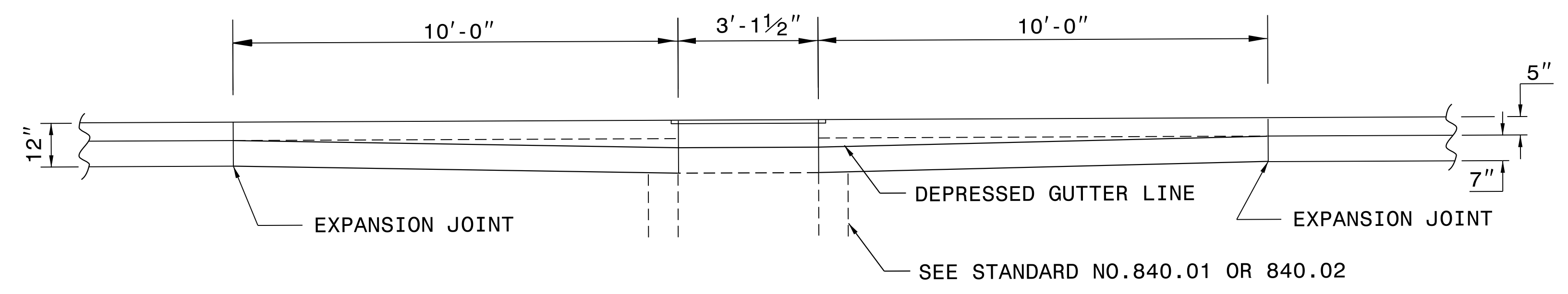

\* MAINTAIN THE EDGE OF PAVEMENT. TRANSITION THE CURB ALONG THE BACK OF THE CURB.

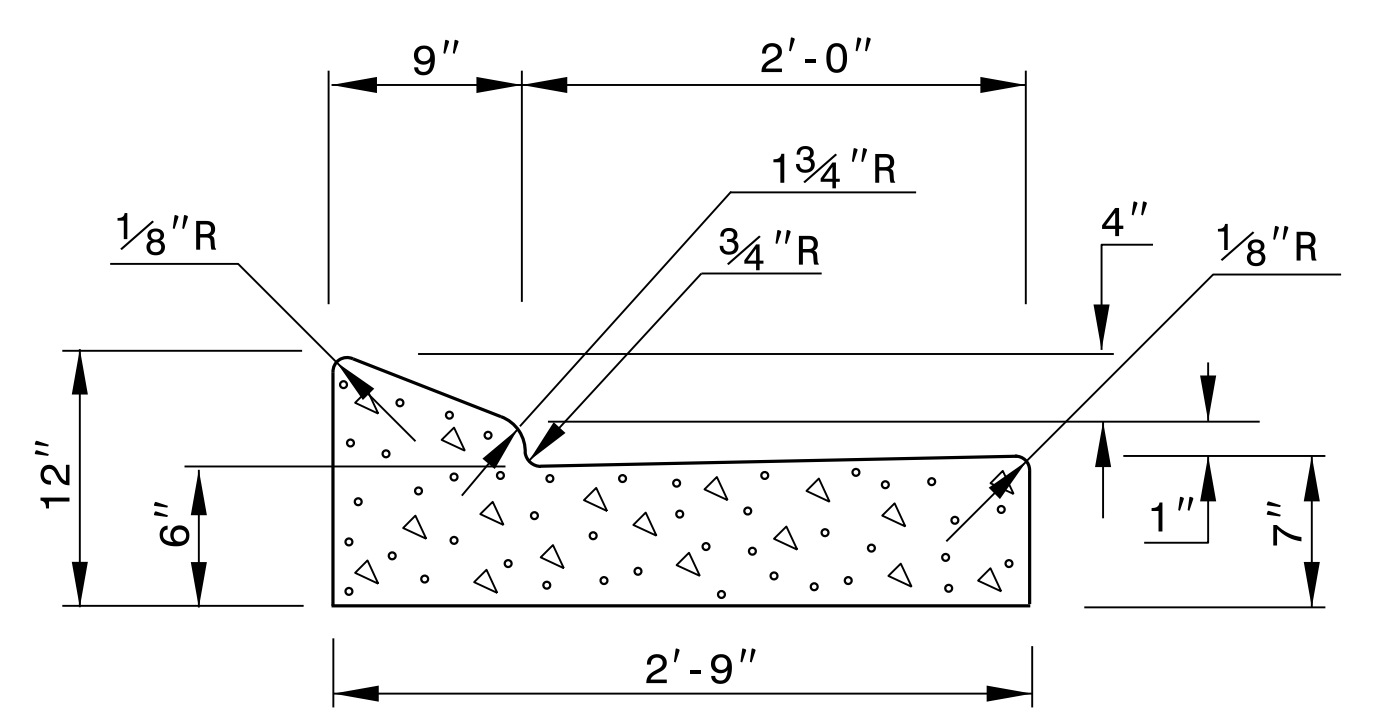
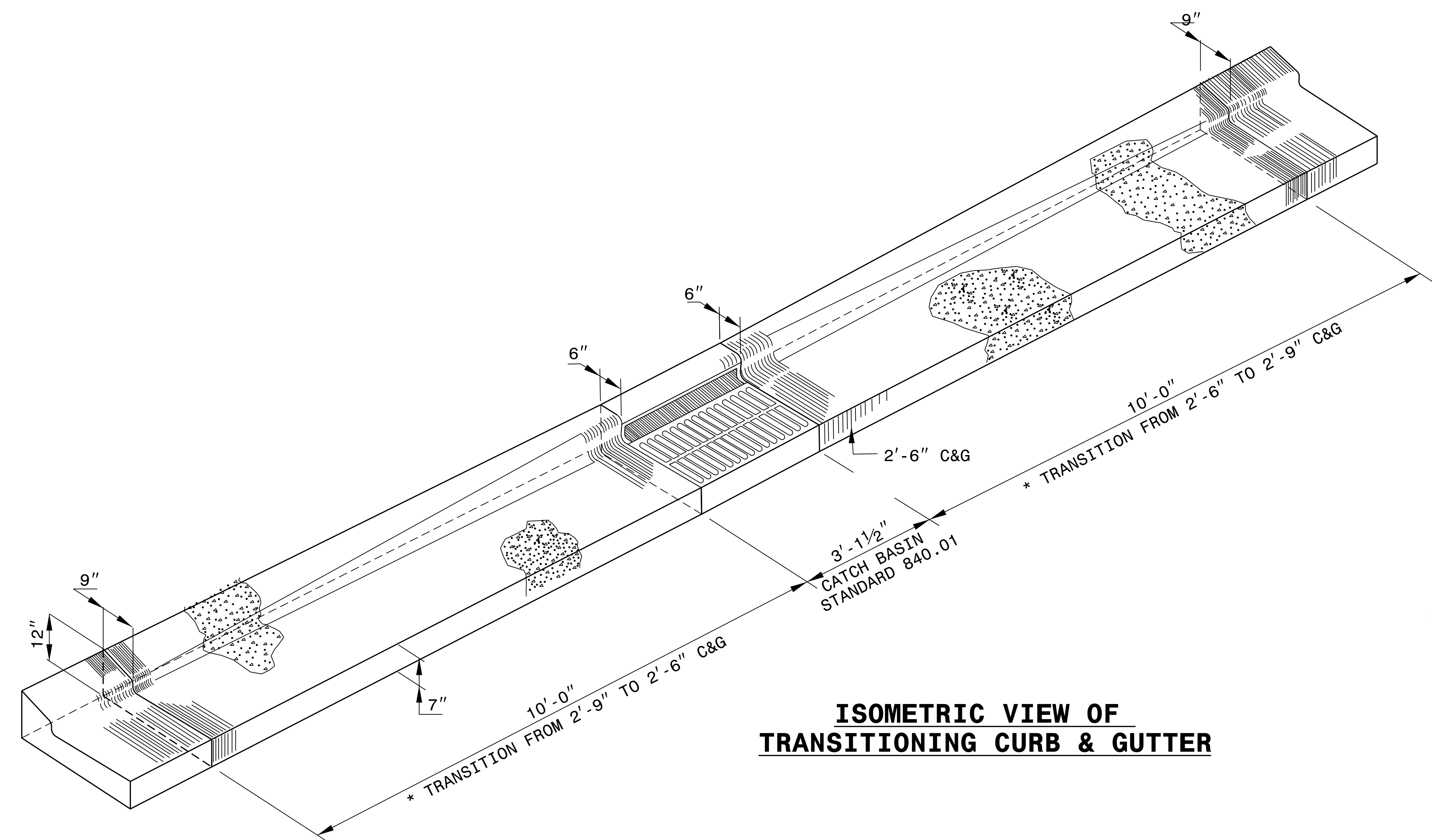
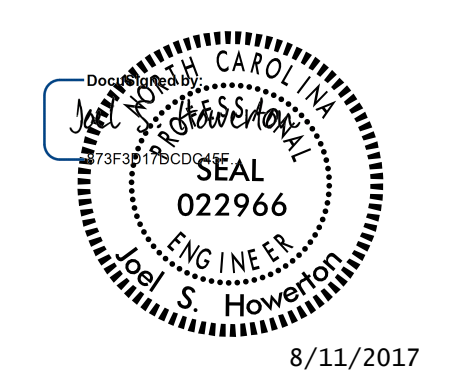

DOCUMENT NOT CONSIDERED FINAL  
UNLESS ALL SIGNATURES COMPLETED

**CONTRACT STANDARDS  
AND DEVELOPMENT UNIT**  
Office 919-707-6950 FAX 919-250-4119

**DETAIL OF 2'-9"  
TO 2'-6" CURB & GUTTER  
TRANSITION SECTION**

ORIGINAL BY: \_\_\_\_\_ DATE: \_\_\_\_\_  
 MODIFIED BY: tspell DATE: july 14,2009  
 CHECKED BY: \_\_\_\_\_ DATE: \_\_\_\_\_  
 FILE SPEC.: s:eric/usr/details/stand/cqtranst.dgn

27-JUN-2017 10:44  
 S:\Contracts\Special Details\ericward\usr\details\stand\c&g transition sections.dgn  
 Jhowerton AT USD-292595