

BAR TYPES

BILL OF MATERIAL

INTEGRAL END BENT 1					
BAR NO.	NO.	SIZE	TYPE	LENGTH	WEIGHT
B1	8	#9	1	47'-7"	1294
B2	8	#9	1	46'-4"	1260
B3	30	#4	STR	29'-7"	593
B4	21	#4	STR	3'-4"	47
H1	19	#5	2	13'-9"	272
H2	19	#5	2	13'-7"	269
H3	19	#5	3	13'-3"	263
H4	19	#5	3	13'-1"	259
K1	24	#4	STR	3'-8"	59
S1	101	#4	4	11'-4"	765
S2	101	#4	5	4'-1"	267
S3	40	#4	6	6'-6"	174
V1	120	#4	STR	6'-0"	481
V2	74	#4	STR	9'-3"	457

REINFORCING STEEL		LBS.	6,468
CLASS A CONCRETE			
POUR #1 CAP, LOWER WINGS & CONC. COLLARS	C.Y.	52.3	
POUR #2 UPPER PART OF WINGS	C.Y.	6.7	
TOTAL CLASS A CONCRETE	C.Y.	59.0	
HP 12 X 53 STEEL PILES			
NO.: 10	LIN. FT.	675	
PILE DRIVING EQUIPMENT SETUP FOR HP 12 X 53 STEEL PILES			
	EACH	10	

ALL BAR DIMENSIONS ARE OUT TO OUT.

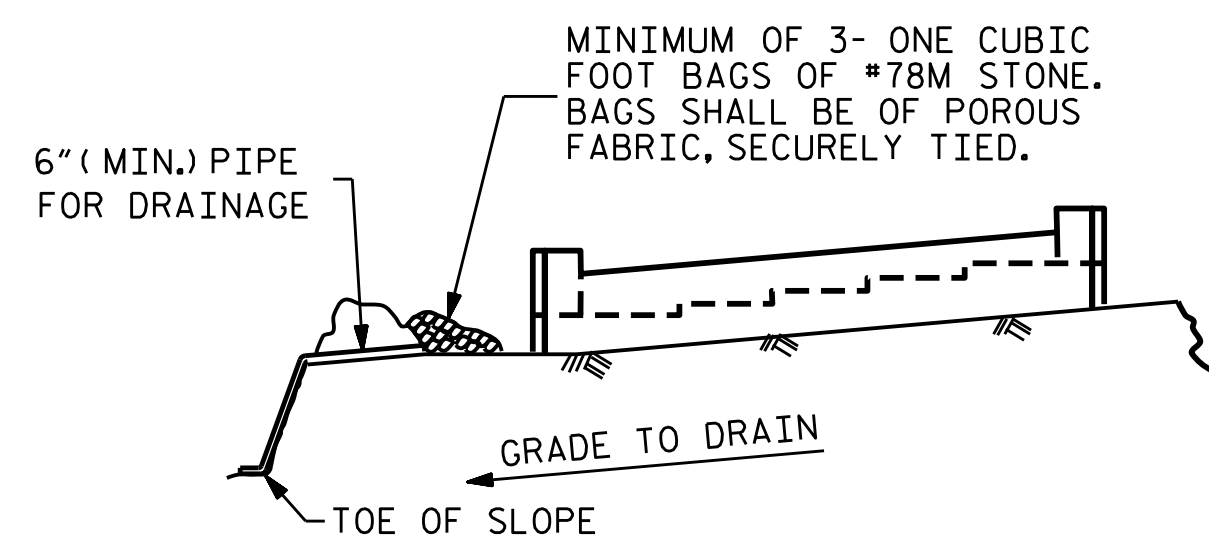
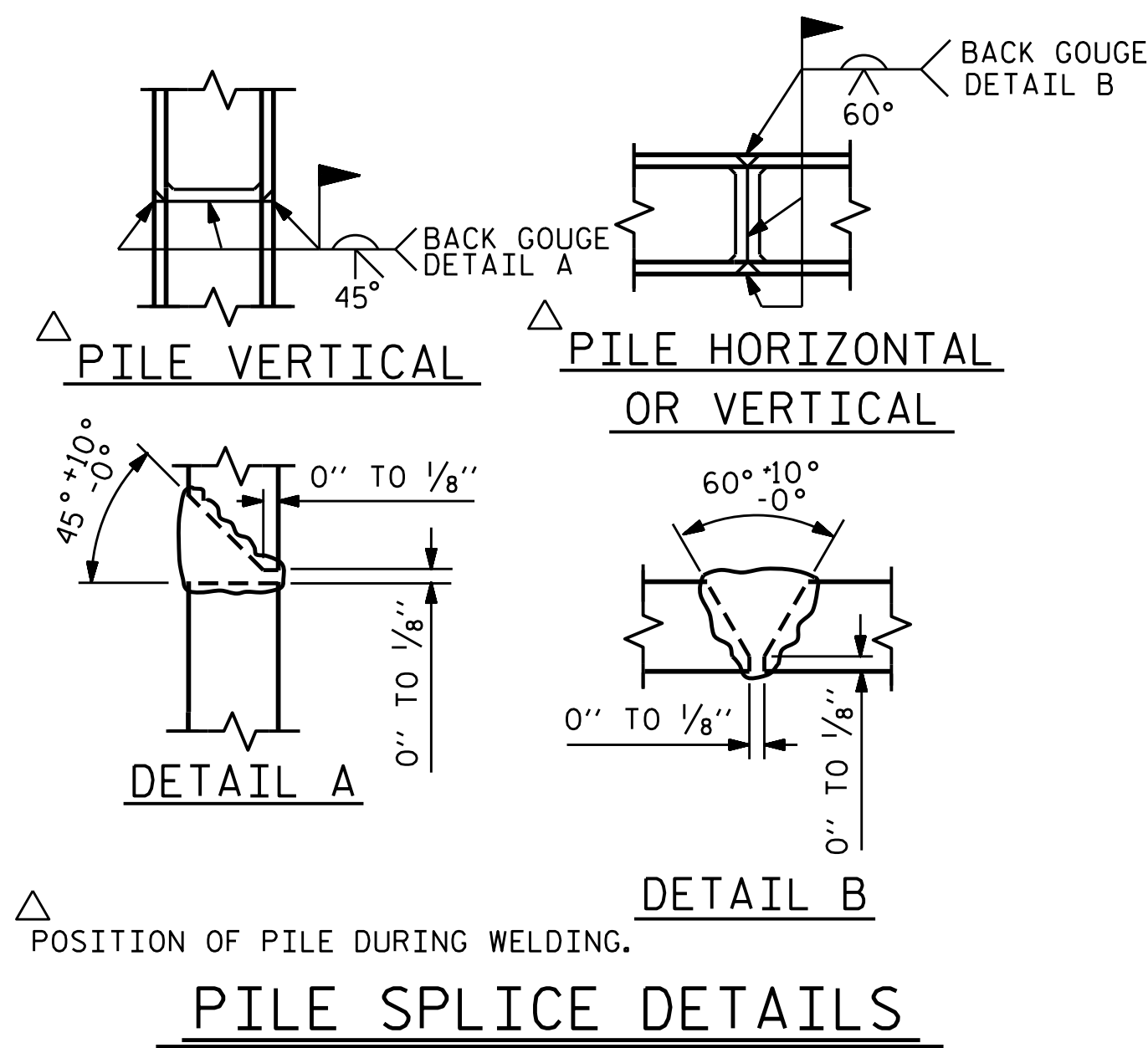

BAGGED STONE AND PIPE SHALL BE PLACED IMMEDIATELY AFTER COMPLETION OF END BENT EXCAVATION. PIPE MAY BE EITHER CONCRETE, CORRUGATED STEEL, CORRUGATED ALUMINUM ALLOY, OR CORRUGATED PLASTIC. PERFORATED PIPE WILL NOT BE ALLOWED.

BAGGED STONE SHALL REMAIN IN PLACE UNTIL THE ENGINEER DIRECTS THAT IT BE REMOVED. THE CONTRACTOR SHALL REMOVE AND DISPOSE OF SILT ACCUMULATIONS AT BAGGED STONE WHEN SO DIRECTED BY THE ENGINEER. BAGS SHALL BE REMOVED AND REPLACED WHENEVER THE ENGINEER DETERMINES THAT THEY HAVE DETERIORATED AND LOST THEIR EFFECTIVENESS.

NO SEPARATE PAYMENT WILL BE MADE FOR THIS WORK AND THE ENTIRE COST OF THIS WORK SHALL BE INCLUDED IN THE UNIT CONTRACT PRICE BID FOR THE SEVERAL PAY ITEMS.

PROJECT NO. U-2579C
FORSYTH COUNTY
 STATION: 473+70.00 -L-
 SHEET 3 OF 3

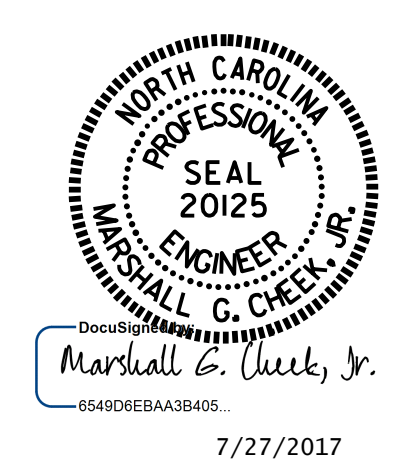

STATE OF NORTH CAROLINA
 DEPARTMENT OF TRANSPORTATION
 RALEIGH

SUBSTRUCTURE
 INTEGRAL
 END BENT 1
 (LEFT LANE)

DRAWN BY: H.A. LOCKLEAR DATE: 6/23/16
 CHECKED BY: K.D. LAYNE DATE: 8/3/16
 DESIGN ENGINEER OF RECORD: H.A. LOCKLEAR DATE: 8/18/16

DOCUMENT NOT CONSIDERED FINAL UNLESS ALL SIGNATURES COMPLETED

REVISIONS						SHEET NO.	
NO.	BY:	DATE:	NO.	BY:	DATE:	S3-23	
1			3			TOTAL SHEETS	33
2			4				