

TIP NO. U-2579C	SHEET NO. PMP-18
APPROVED: <i>Andrew D. Klinck</i> E3078F8459E44B	
DATE: 7/3/2017	
	
DOCUMENT NOT CONSIDERED FINAL UNLESS ALL SIGNATURES COMPLETED	

(A) TYPE III BARRICADES WILL REMAIN IN PLACE AT THE COMPLETION OF THE PROJECT. SEE SPECIAL PROVISIONS

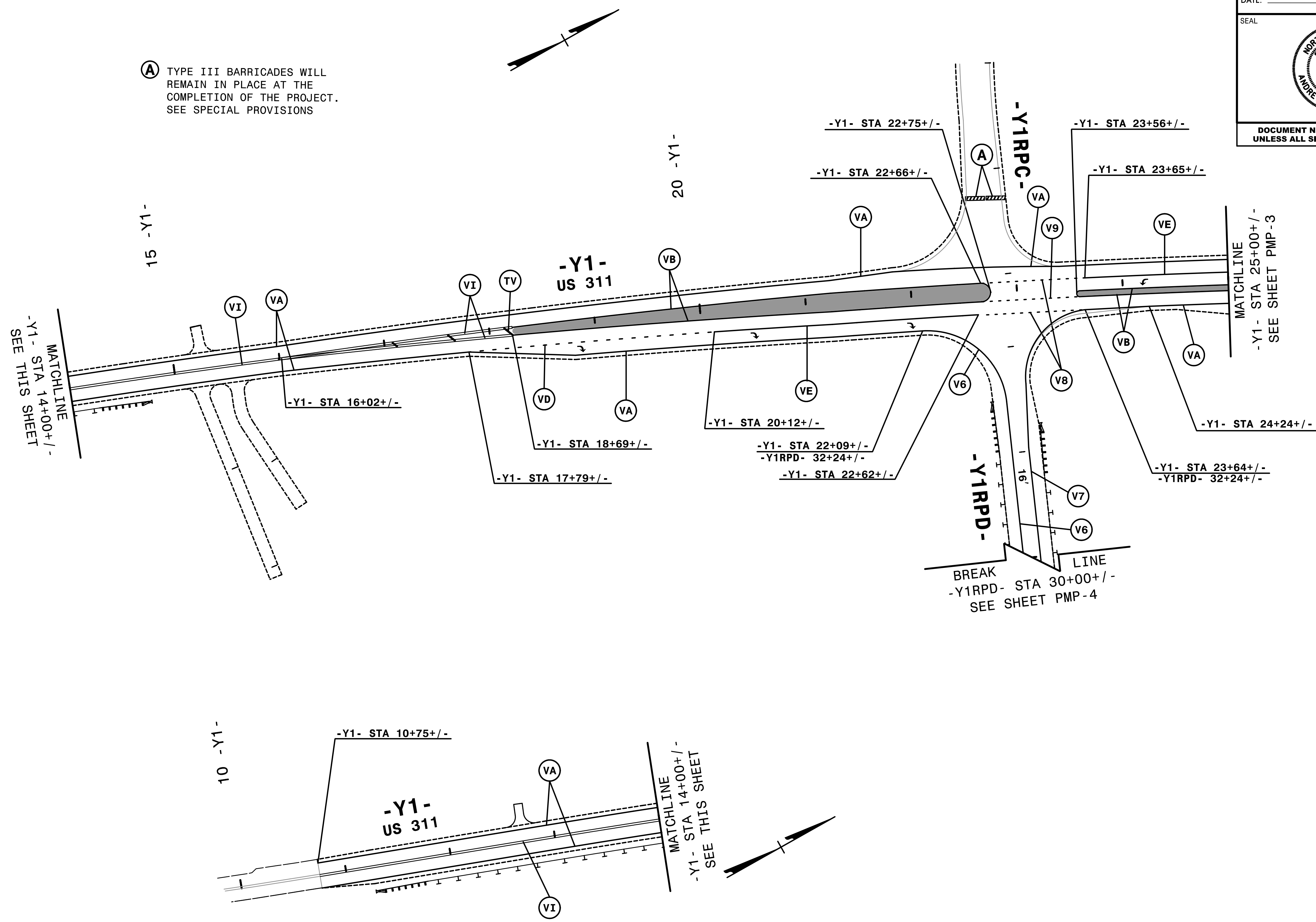

MATCHLINE
-Y1- STA 14+00+/-
SEE THIS SHEET

MATCHLINE
-Y1- STA 25+00+/-
SEE SHEET PMP-3

BREAK
-Y1RPD- STA 30+00+/-
SEE SHEET PMP-4

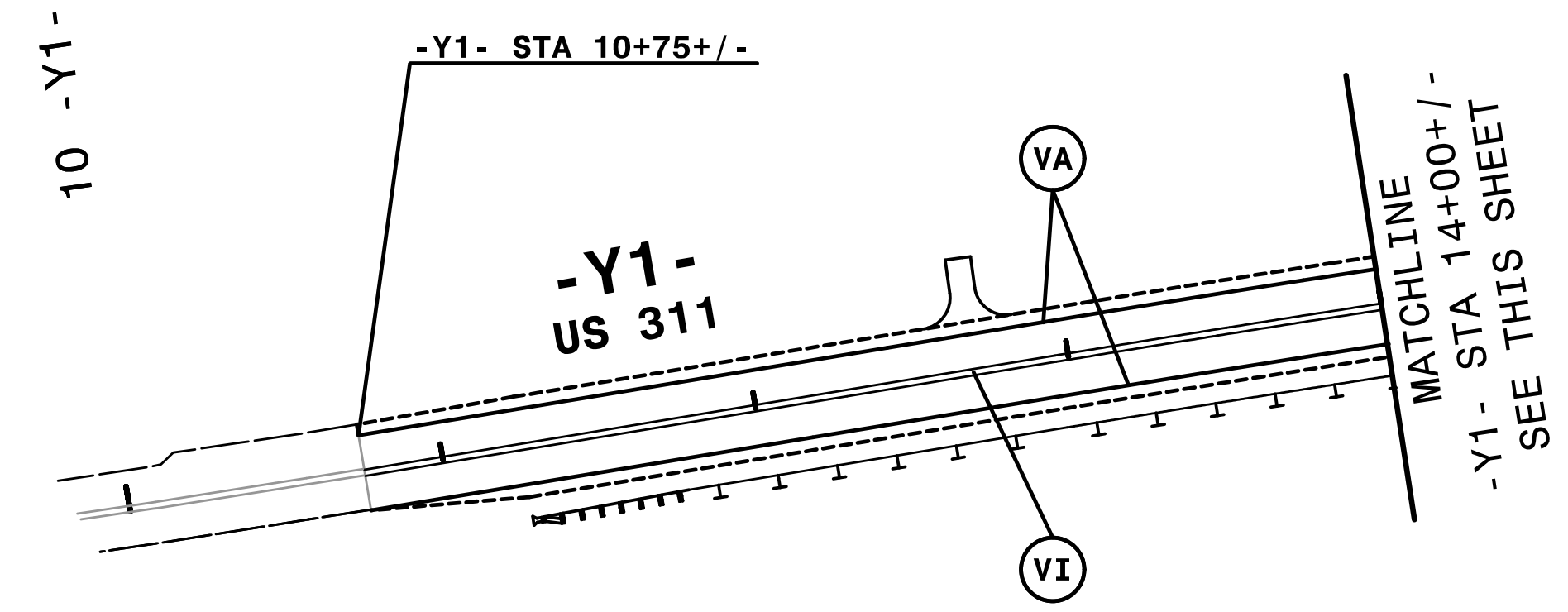

NOTE: ALL LANE WIDTHS ARE 12' UNLESS OTHERWISE SHOWN.

I:\47406_PMP\U-2579C_pmp_18.dgn
 HNTB

HNTB HNTB NORTH CAROLINA, P.C.
 343 E. Six Forks Road, Suite 200
 Raleigh, North Carolina 27609
 NC License No: C-1554
 (919) 546-8997

PAVEMENT MARKING DETAIL