

NOTES

STIRRUPS IN CAP MAY BE SHIFTED AS NECESSARY TO CLEAR DOWELS.

THE CONCRETE IN THE SHADED AREA OF THE WING SHALL BE POURED AFTER THE VERTICAL CONCRETE BARRIER RAIL IS CAST IF SLIP FORMING IS USED.

FOR PILE SPLICE DETAILS, SEE SHEET 4 OF 4.

FOR WING DETAILS, SEE SHEET 3 OF 4.

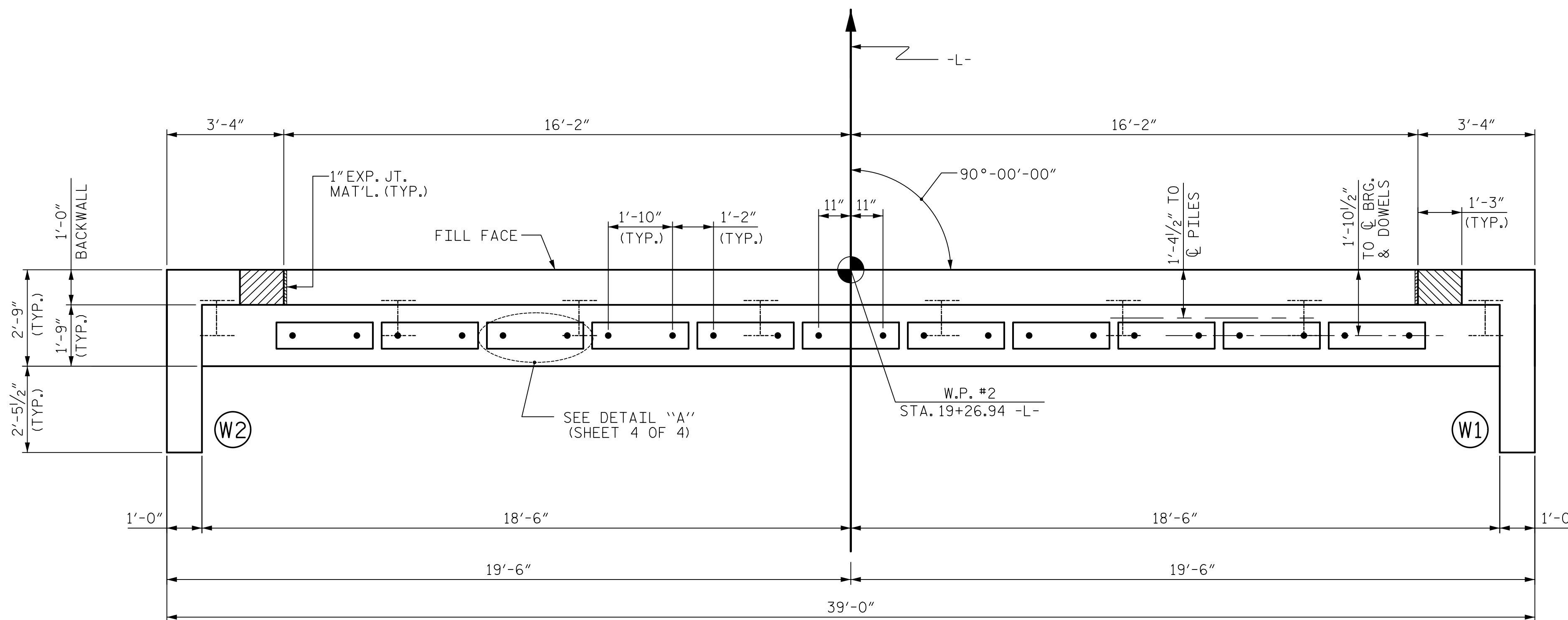

PLAN

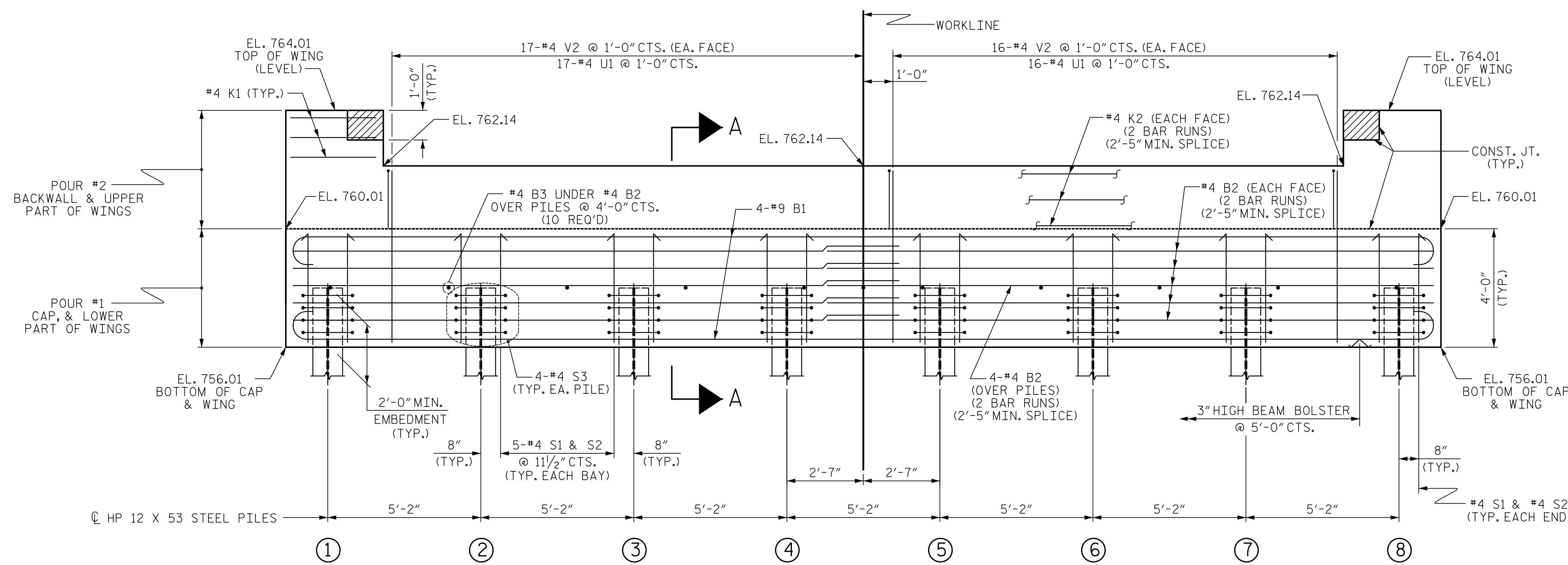

ELEVATION  
WINGS NOT SHOWN FOR CLARITY.  
FOR SECTION A-A, SEE SHEET 4 OF 4.

**Mead & Hunt**

133 Fayetteville Street  
Suite 210  
Raleigh, NC 27601  
919-714-8670  
meadhunt.com  
NC License No. F-1235



DocuSigned by:  
Jack Hobson 6/1/2017

PROJECT NO. B-4964  
ROCKINGHAM COUNTY  
STATION: 18+73.69 -L-  
12+70.54 -RAIL-  
SHEET 2 OF 4

STATE OF NORTH CAROLINA  
DEPARTMENT OF TRANSPORTATION  
RALEIGH

SUBSTRUCTURE  
END BENT No. 2

DRAWN BY : J.S. HOBSON DATE : 06/30/16  
CHECKED BY : J.A. LEE DATE : 07/08/16  
DESIGN ENGINEER OF RECORD : J.S. HOBSON DATE : 07/08/16

DOCUMENT NOT CONSIDERED  
FINAL UNLESS ALL  
SIGNATURES COMPLETED

REVISIONS						SHEET NO.
NO.	BY:	DATE:	NO.	BY:	DATE:	S-12
1			3			TOTAL SHEETS
2			4			16