

EXISTING JOINT

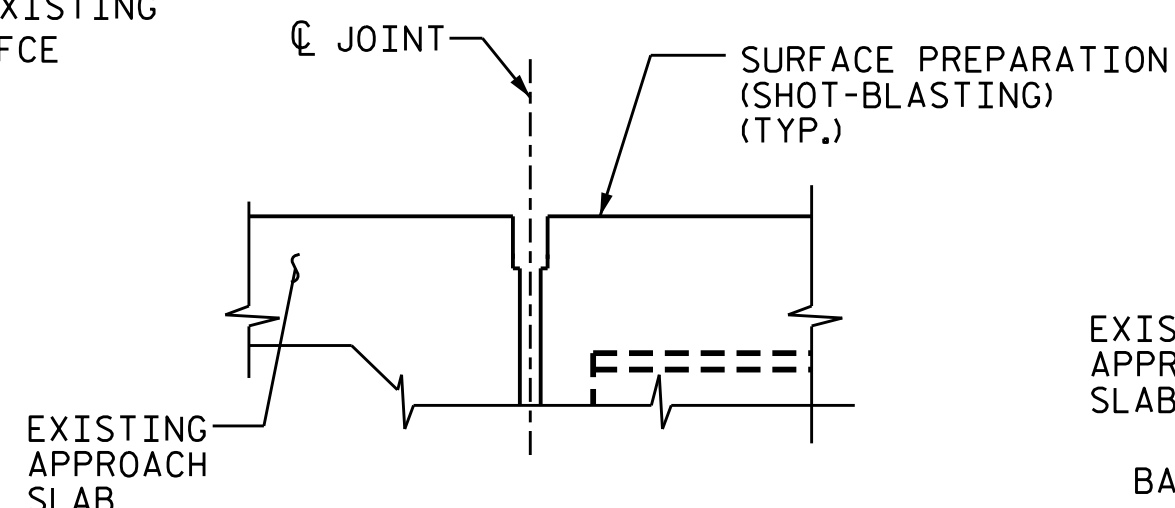

MINIMUM EXISTING JOINT DEMOLITION

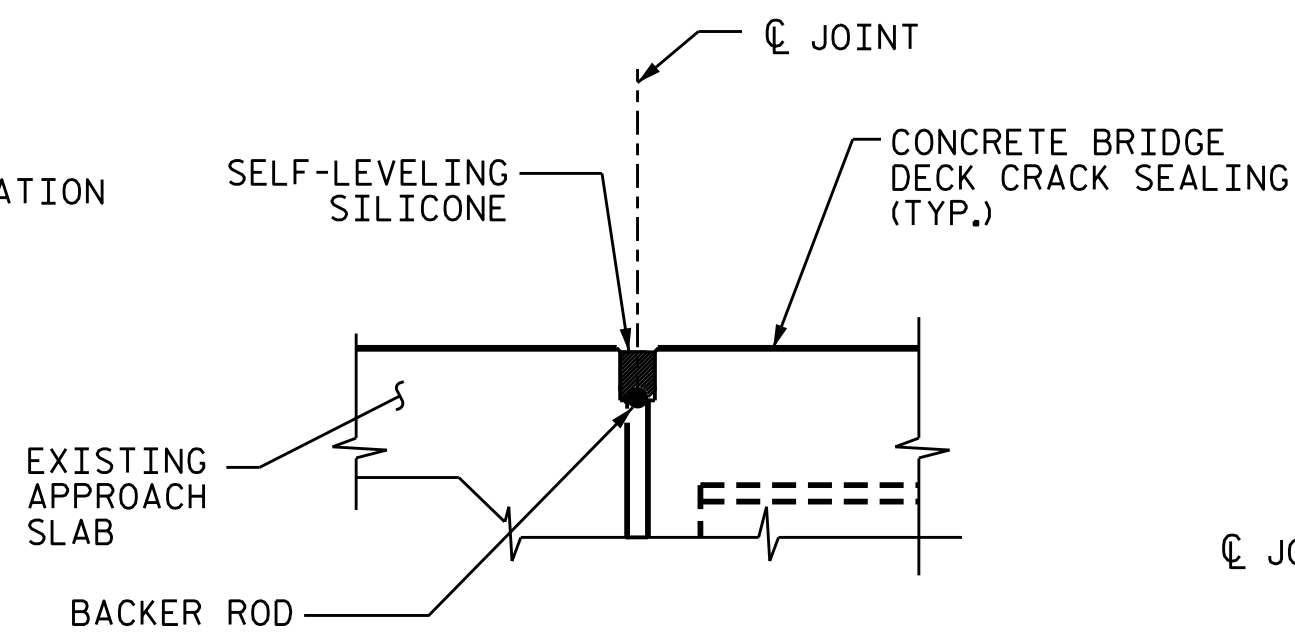

PROPOSED JOINT

JOINT INSTALLATION SEQUENCE AT END BENTS

SECTION A-A

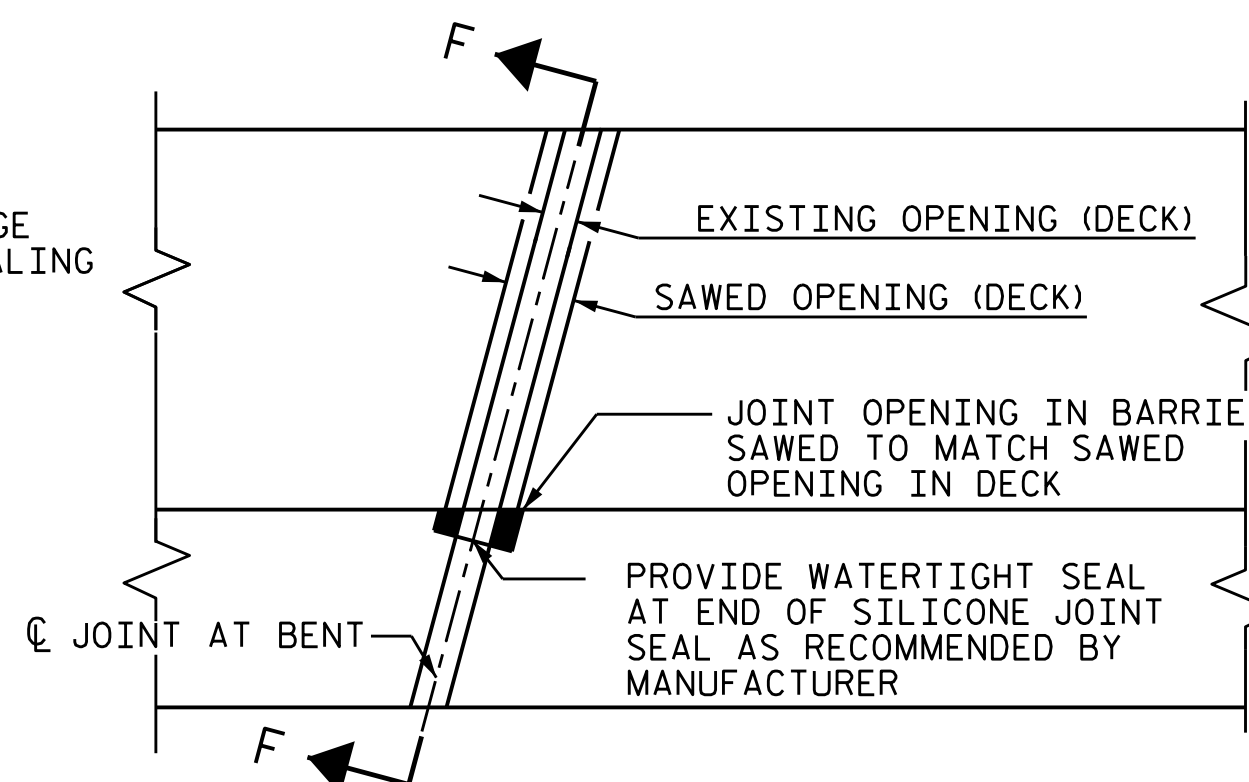

PLAN

NOTES:

CONTRACTOR SHALL FIELD VERIFY THE EXISTING FORMED OPENING PRIOR TO OBTAINING JOINT MATERIAL.

FOR SILICONE JOINT SEALANT, SEE SPECIAL PROVISIONS.

FOR ELASTOMERIC CONCRETE, SEE SPECIAL PROVISIONS.

UNLESS NOTED OTHERWISE RETAIN ALL EXISTING REINFORCING STEEL. CLEAN AND REPAIR AS NEEDED.

ALL EXPOSED ENDS OF CUT BARS SHALL BE COATED WITH EPOXY PRIOR TO THE NEW JOINT MATERIAL INSTALLATION.

JOINT DEMOLITION EXCAVATION OF CONCRETE AT THE EXISTING JOINT SHALL RESULT IN THE BOTTOM OF THE EXCAVATION BEING REASONABLY FLAT, TO PROVIDE SUFFICIENT SUBSTRATE FOR PLACEMENT AND SUPPORT OF ELASTOMERIC CONCRETE.

MAXIMUM DEPTH OF ELASTOMERIC CONCRETE SHALL BE 4". IF DEPTH OF JOINT DEMOLITION EXCAVATION EXCEEDS 1" BELOW THE PLANNED 3" DEPTH OF ELASTOMERIC CONCRETE HEADER, PLACE CONCRETE FOR DECK REPAIR TO BOTTOM OF THE ELASTOMERIC CONCRETE HEADER.

\*\* DIMENSIONS INDICATED ARE GENERIC. ACTUAL DEMOLITION DIMENSIONS SHALL BE SUFFICIENT TO REMOVE THE HOLD-DOWN PLATE AND BASE ANGLES. BASE ANGLE STUDS MAY REMAIN, BUT SHALL BE CUT FLUSH WITH BOTTOM OF EXCAVATION.

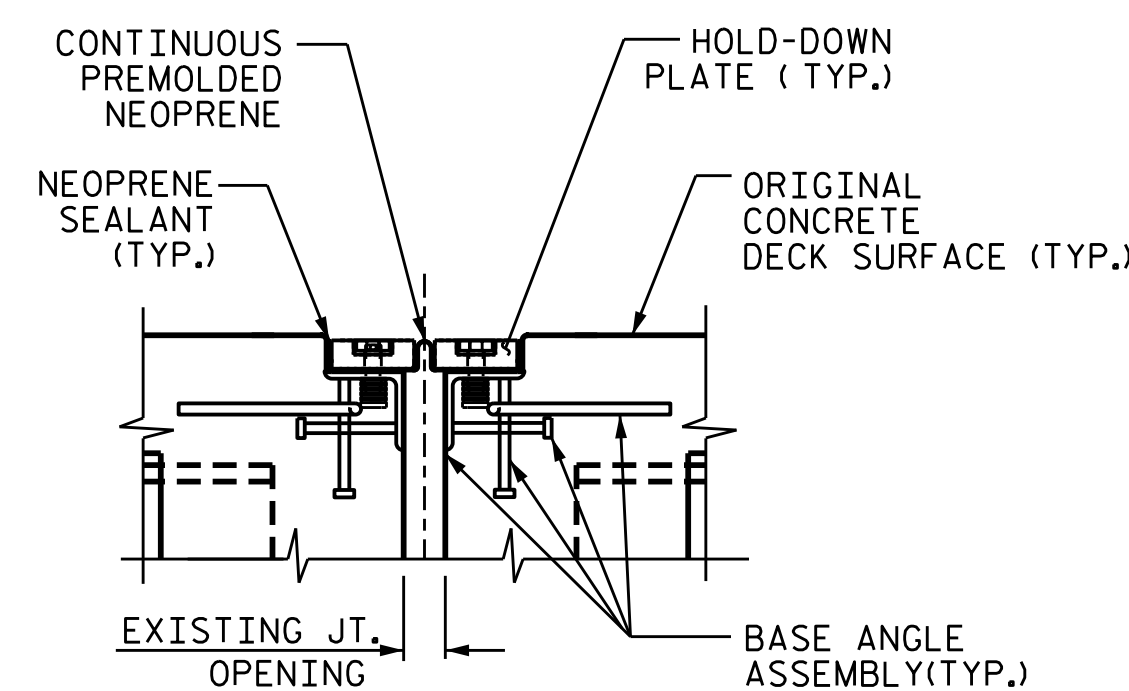

EXISTING JOINT

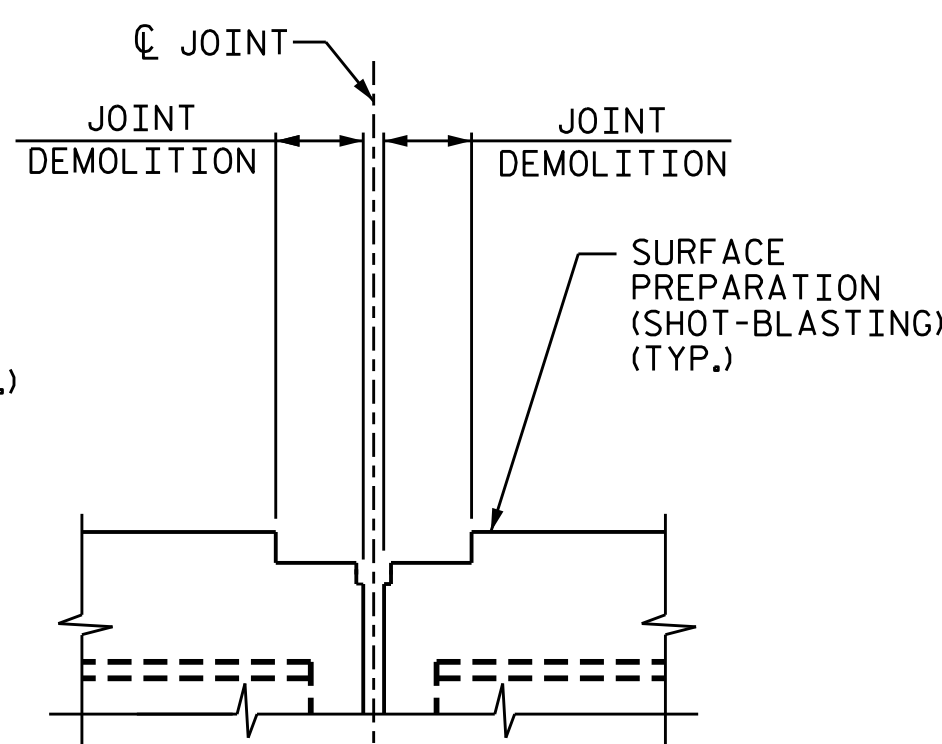

MINIMUM EXISTING JOINT DEMOLITION

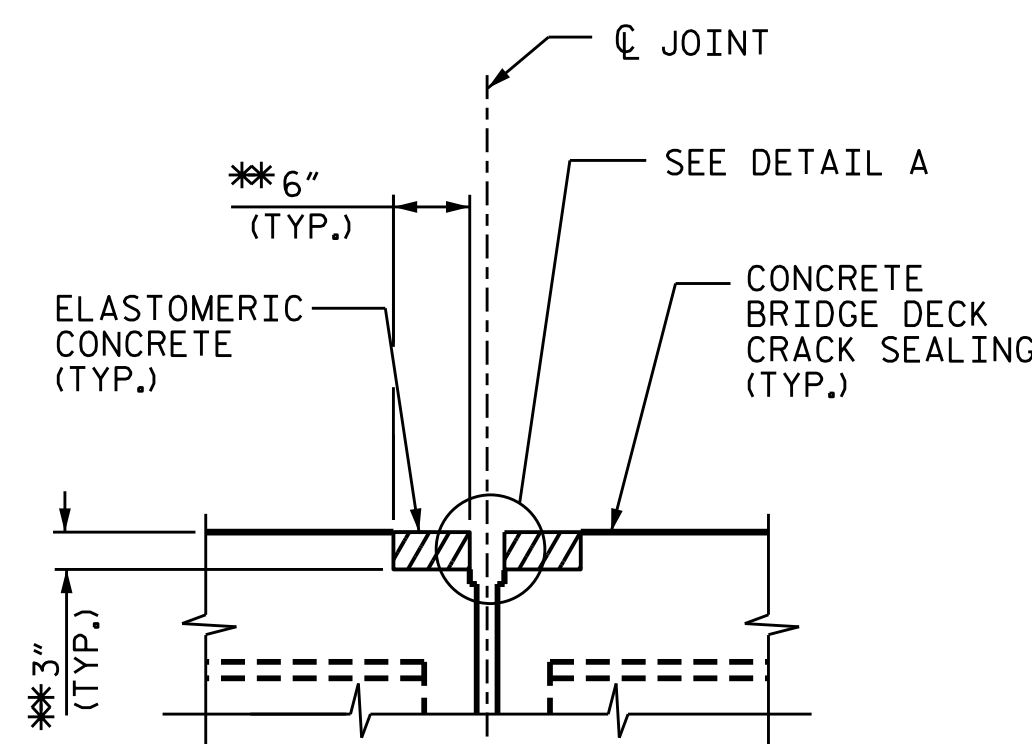

PROPOSED JOINT

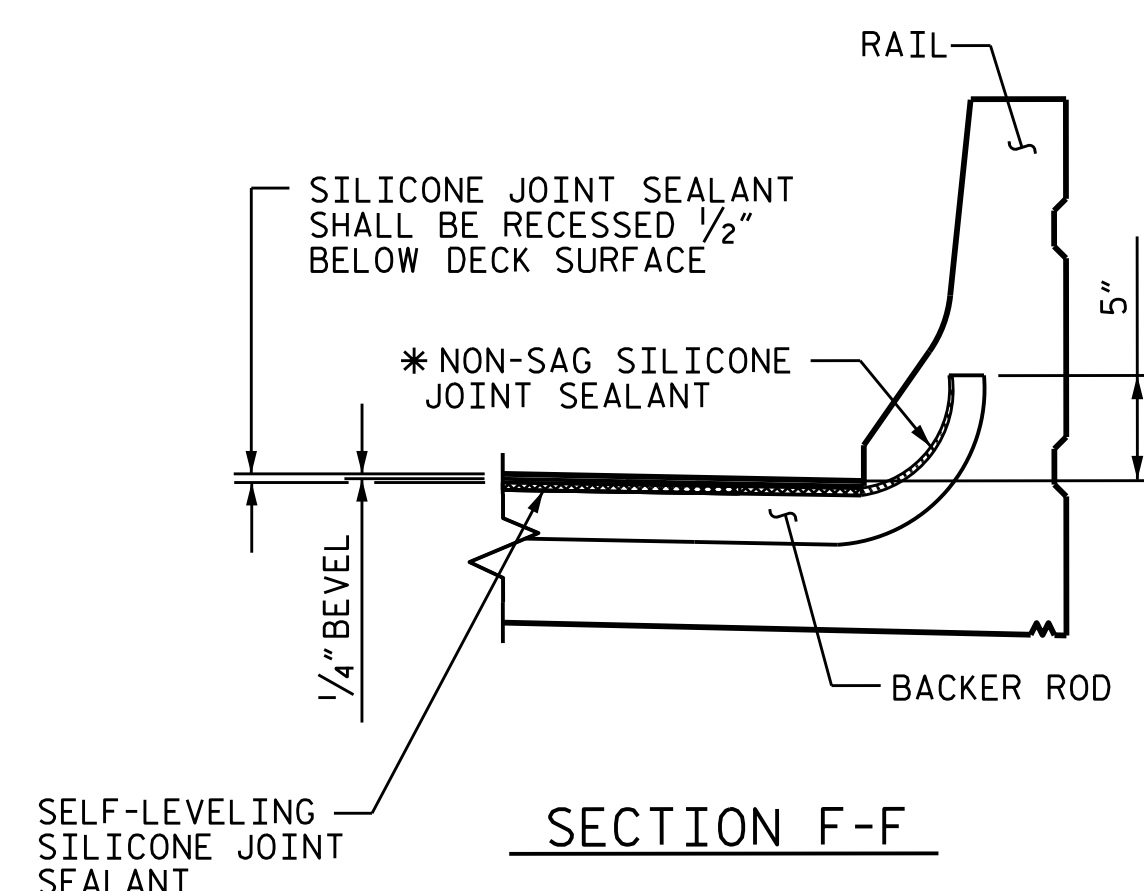

SECTION F-F

\* NON-SAG SILICONE JOINT SEALANT TO BE PLACED AND ALLOWED TO SET, PRIOR TO PLACEMENT OF SELF-LEVELING SILICONE JOINT SEALANT.

JOINT INSTALLATION SEQUENCE AT BENT 1

SECTION B-B

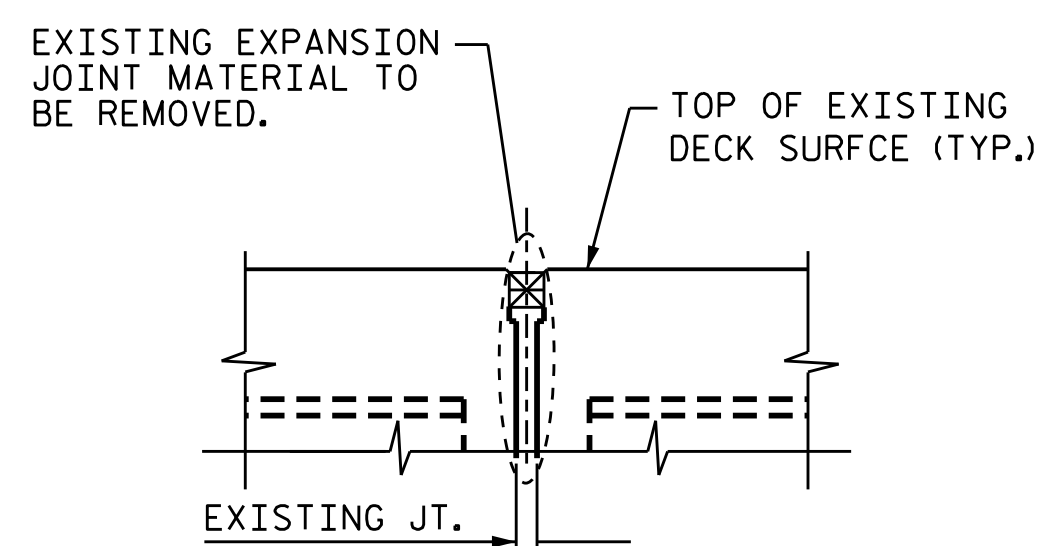

(EXISTING JOINT)

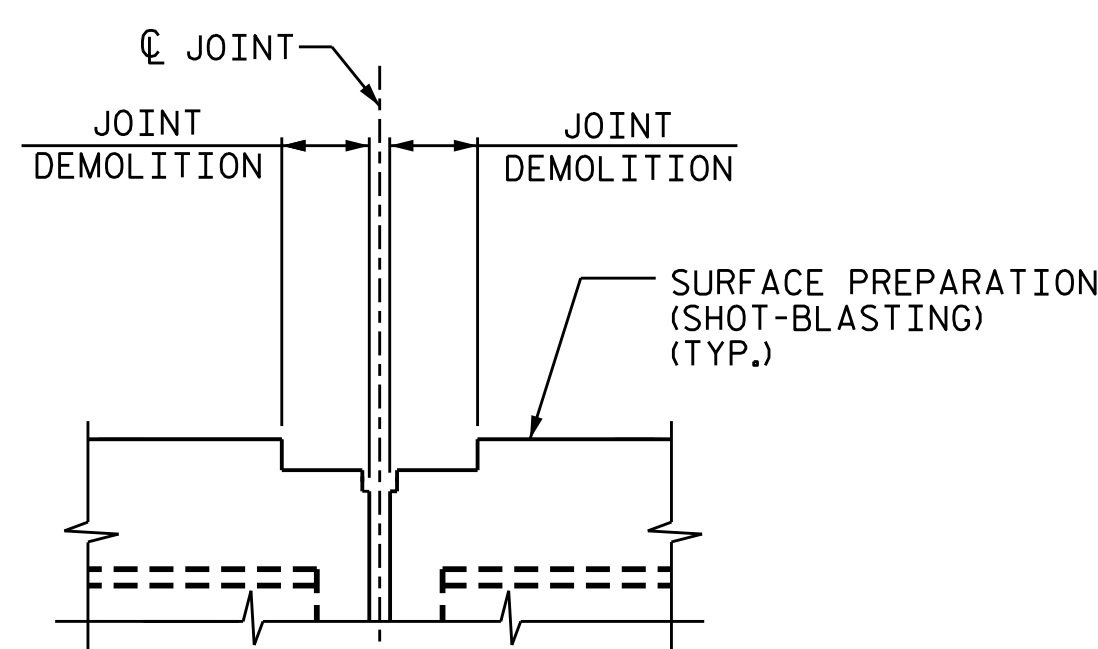

MINIMUM EXISTING JOINT DEMOLITION

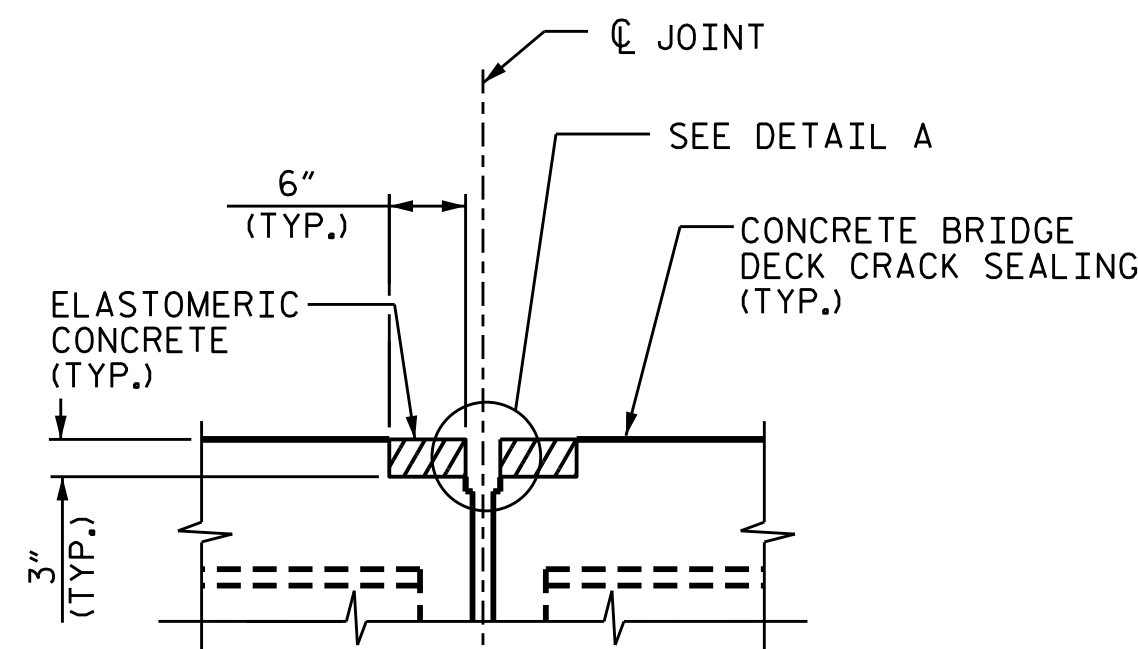

PROPOSED JOINT

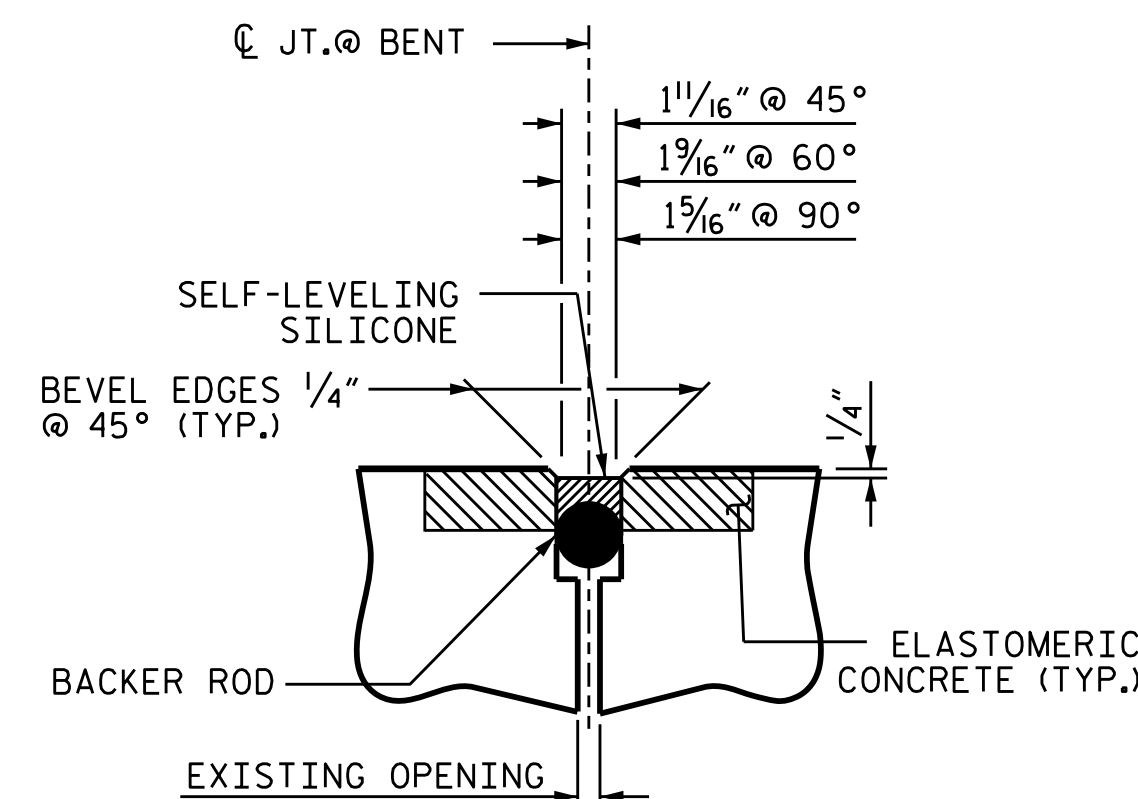

DETAIL A (PROPOSED)

JOINT INSTALLATION SEQUENCE AT BENT 2

SECTION C-C

PROJECT NO. I-5839  
 HALIFAX COUNTY  
 BRIDGE No.: 124 & 129

STATE OF NORTH CAROLINA  
 DEPARTMENT OF TRANSPORTATION  
 RALEIGH

SUPERSTRUCTURE  
 JOINT DETAILS



DocuSigned by:  
 Aster Abramo

DRAWN BY: M. K. BEARD / S. T. SANDOR DATE: 03/2017  
 CHECKED BY: W. C. SMITH DATE: 05/2017

DOCUMENT NOT TO BE CONSIDERED FINAL UNLESS ALL SIGNATURES COMPLETED

REVISIONS						SHEET NO.
NO.	BY:	DATE:	NO.	BY:	DATE:	S-9
1			3			TOTAL SHEETS 42
2			4			