

BILL OF MATERIAL					
BAR	NO.	SIZE	TYPE	LENGTH	WEIGHT
* A1	158	#5	STR	42'-11"	7072
A2	158	#5	STR	42'-11"	7072
* A101	4	#5	STR	39'-7"	165
* A102	4	#5	STR	35'-8"	149
* A103	4	#5	STR	31'-9"	132
* A104	4	#5	STR	27'-10"	116
* A105	4	#5	STR	23'-11"	100
* A106	4	#5	STR	20'-0"	83
* A107	4	#5	STR	16'-1"	67
* A108	4	#5	STR	12'-2"	51
* A109	4	#5	STR	8'-3"	34
* A110	4	#5	STR	4'-4"	18
A201	4	#5	STR	39'-7"	165
A202	4	#5	STR	35'-8"	149
A203	4	#5	STR	31'-9"	132
A204	4	#5	STR	27'-10"	116
A205	4	#5	STR	23'-11"	100
A206	4	#5	STR	20'-0"	83
A207	4	#5	STR	16'-1"	67
A208	4	#5	STR	12'-2"	51
A209	4	#5	STR	8'-3"	34
A210	4	#5	STR	4'-4"	18
* B1	8	#4	STR	29'-7"	158
* B2	170	#6	STR	23'-0"	5873
* B3	87	#4	STR	24'-9"	1438
B4	64	#7	STR	23'-0"	3009
B5	64	#5	STR	36'-5"	2431
K1	24	#4	STR	22'-5"	359
K2	32	#4	STR	8'-2"	175
K3	8	#4	STR	6'-6"	35
K4	8	#4	STR	5'-0"	27
K5	16	#4	STR	3'-8"	39
K6	4	#4	STR	2'-10"	8
K7	4	#4	STR	2'-1"	6
* S1	52	#4	1	11'-11"	414
* S2	48	#4	1	11'-5"	366
U1	48	#4	2	13'-6"	433
U2	4	#4	2	12'-7"	34

ALL BAR DIMENSIONS ARE OUT TO OUT

—SUPERSTRUCTURE BILL OF MATERIAL—

	CLASS AA CONCRETE (CU. YDS.)	REINFORCING STEEL (LBS.)	* EPOXY COATED REINFORCING STEEL (LBS.)
POUR #1	138.8		
POUR #2	83.8		
TOTALS**	222.6	14,543	16,236

REINFORCING STEEL	LBS.	14,543
* EPOXY COATED REINFORCING STEEL	LBS.	16,236

**QUANTITIES FOR BARRIER RAIL ARE NOT INCLUDED

* THESE BARS ARE EPOXY COATED.

GROOVING BRIDGE FLOORS	
APPROACH SLABS	1,798 SQ.FT.
BRIDGE DECK	4,166 SQ.FT.
TOTAL	5,964 SQ.FT.

PROJECT NO. R-5719
 WAYNE COUNTY
 STATION: 39+11.12 -L-

BAR SIZE	SUPERSTRUCTURE REINFORCING STEEL LENGTHS ARE BASED ON THE FOLLOWING MINIMUM SPLICE LENGTHS		APPROACH SLABS		PARAPET AND BARRIER RAIL
	EPOXY COATED	UNCOATED	EPOXY COATED	UNCOATED	
#4	2'-0"	1'-9"	2'-0"	1'-9"	2'-9"
#5	2'-6"	2'-2"	2'-6"	2'-2"	3'-5"
#6	3'-0"	2'-7"	3'-10"	2'-7"	4'-4"
#7	5'-3"	3'-6"			
#8	6'-10"	4'-7"			

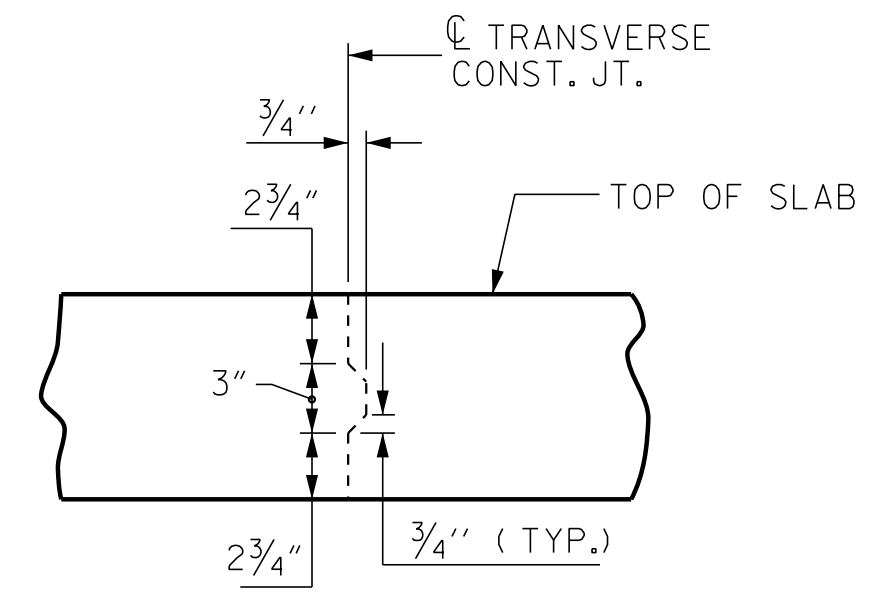

TRANSVERSE CONSTRUCTION JOINT DETAIL

NOTE: REINFORCING STEEL IN SLAB NOT SHOWN. LONGITUDINAL REINFORCING STEEL SHALL BE CONTINUOUS THRU JOINT

DOCUMENT NOT CONSIDERED FINAL UNLESS ALL SIGNATURES COMPLETED

ENGINEER OF RECORD
 12/12/2016
 NORTH CAROLINA PROFESSIONAL SEAL 14091
 ENGINEER
 CHARLES HUNT
 DocuSigned by:
 Buck Charles Hunt
 0163027846AC

ETHERILL ENGINEERING
 1223 Jones Franklin Rd.
 Raleigh, N.C. 27606
 Bus: 919 851 8077
 Fax: 919 851 8107
 LICENSE NO. F-0377

STATE OF NORTH CAROLINA
 DEPARTMENT OF TRANSPORTATION
 RALEIGH

SUPERSTRUCTURE
 BILL OF MATERIAL
 (LEFT LANE)

REVISIONS					
NO.	BY:	DATE:	NO.	BY:	DATE:
1			3		
2			4		

SHEET NO. S01-16
 TOTAL SHEETS 26

P:\2015\A-5719\Structures\DWG\Left Lane\A-5719_L1T_BM_WE.dgn
 12/16/2016 1:16:59 PM

DRAWN BY: D. HODGE DATE: 1/16
 CHECKED BY: G.M. GILLAND DATE: 2/16