

STATE	PROJECT NO.	SHEET NO.	TOTAL SHEETS
N.C.	I-5746A/I-5746B	9	
WBS NO.	52024.3.3		

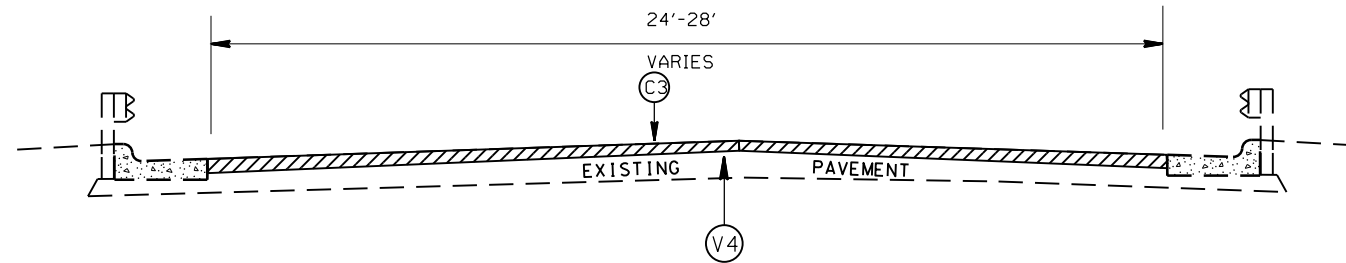

TYPICAL SECTION NO.12

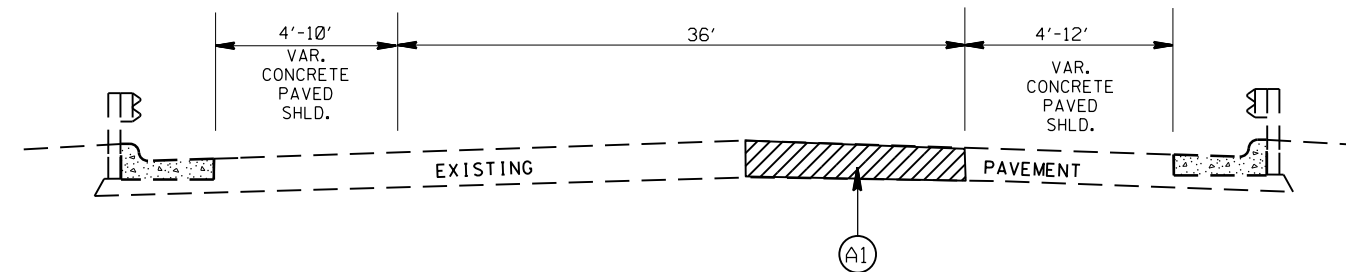

TYPICAL SECTION NO.13

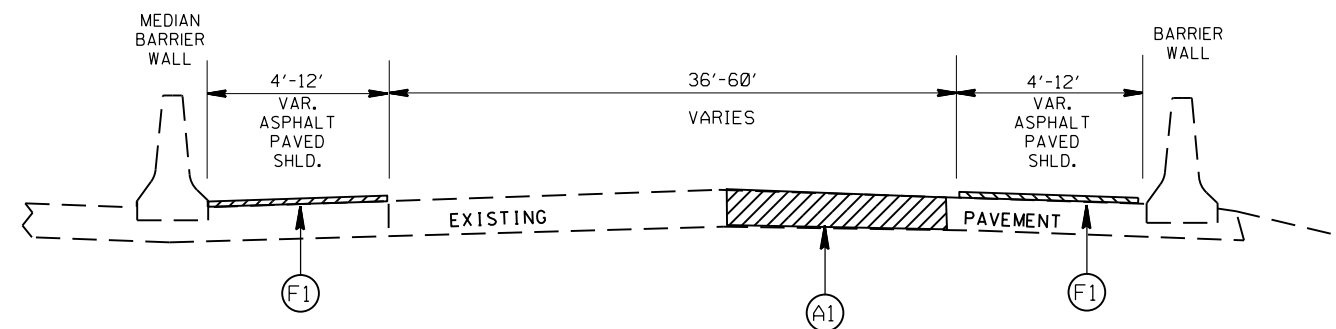

TYPICAL SECTION NO.14

PAVEMENT SCHEDULE	
A1	PROP. APPROX. 11" PORTLAND CEMENT CONCRETE PAVEMENT REPAIR (WITH DOWELS) AT VARIABLE LOCATIONS AS DETERMINED BY THE ENGINEER
C1	PROP. APPROX. 2.0" ASPHALT CONCRETE SURFACE COURSE, TYPE S9.5C, AT AN AVERAGE RATE OF 224 LBS. PER SQ. YD.
C2	PROP. APPROX. 1.5" ASPHALT CONCRETE SURFACE COURSE, TYPE S9.5C, AT AN AVERAGE RATE OF 168 LBS. PER SQ. YD.
C3	PROP. APPROX. 3.0" ASPHALT CONCRETE SURFACE COURSE, TYPE S9.5D, AT AN AVERAGE RATE OF 168 LBS. PER SQ. YD. IN EACH OF 2 LAYERS
F1	FOG SEAL
V2	MILLING 2.0" DEPTH
V3	MILLING 1.5" DEPTH
V4	MILLING, 3.0" DEPTH
T	SHOULDER RECONSTRUCTION
M	MILLED RUMBLE STRIPS

I-5746A/I-5746B Interstate 277 Pavement Rehabilitation

SCALE -NA-
DATE 12/16
DWG. BY TJP
DESIGN BY TJP
APPROVED WAT



REVISIONS
