

NOTES:
 NO SEPARATE MEASUREMENT OR PAYMENT WILL BE MADE FOR MATERIALS OR LABOR REQUIRED TO CONSTRUCT THE CONCRETE MEDIAN. THE ENTIRE COST OF THIS WORK SHALL BE INCLUDED IN THE SQUARE FOOT PRICE BID FOR "REINFORCED CONCRETE DECK SLAB".
 CONCRETE MEDIAN IN A CONTINUOUS UNIT SHALL NOT BE CAST UNTIL ALL SLAB CONCRETE IN THE UNIT HAS BEEN CAST AND HAS REACHED A MINIMUM COMPRESSIVE STRENGTH OF 3,000 PSI.
 THE JOINT IN THE DECK AT THE END BENTS SHALL BE SAWED PRIOR TO CASTING OF THE CONCRETE MEDIAN. THE JOINT IN THE CONCRETE MEDIAN SHALL BE FORMED TO MATCH THE SAWED OPENING IN THE DECK.
 GROOVED CONTRACTION JOINTS 1/2" IN DEPTH, SHALL BE TOOLED IN ALL EXPOSED FACES OF CONCRETE MEDIAN IN ACCORDANCE WITH ARTICLE 825-10(B) OF THE STANDARD SPECIFICATIONS. THE CONTRACTION JOINTS SHALL BE LOCATED AT A SPACING OF 8 FEET TO 10 FEET.

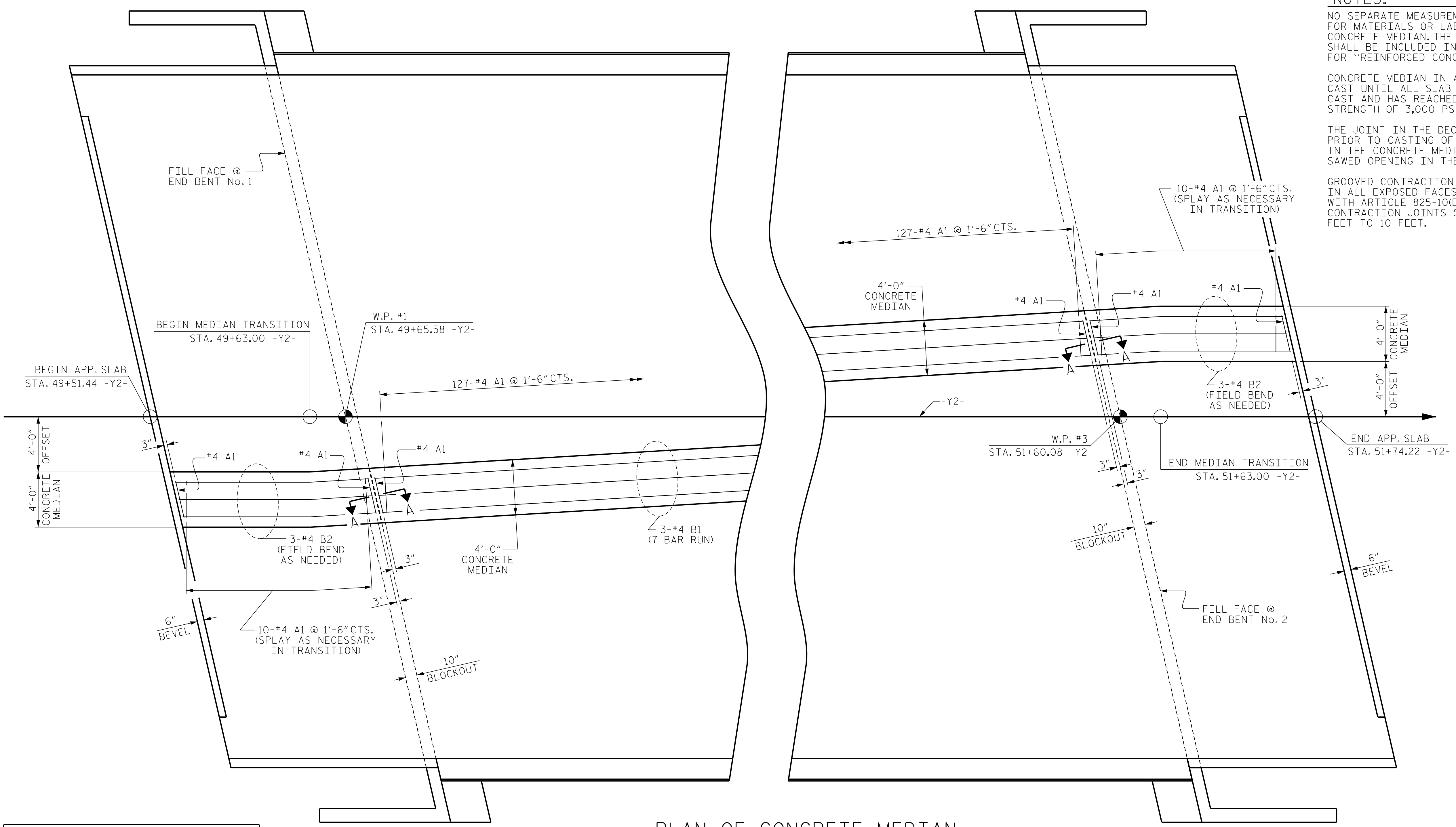

PLAN OF CONCRETE MEDIAN

| BILL OF MATERIAL | | | | | |
|----------------------------------|-----|------|------|---------|---------------|
| FOR CONCRETE MEDIAN ONLY | | | | | |
| BAR | NO. | SIZE | TYPE | LENGTH | WEIGHT |
| * A1 | 153 | #4 | STR | 2'-8" | 273 |
| * B1 | 21 | #4 | STR | 28'-10" | 404 |
| * B2 | 6 | #4 | STR | 14'-0" | 56 |
| * EPOXY COATED REINFORCING STEEL | | | | | 733 LBS. |
| CLASS AA CONCRETE | | | | | 12.2 CU. YDS. |

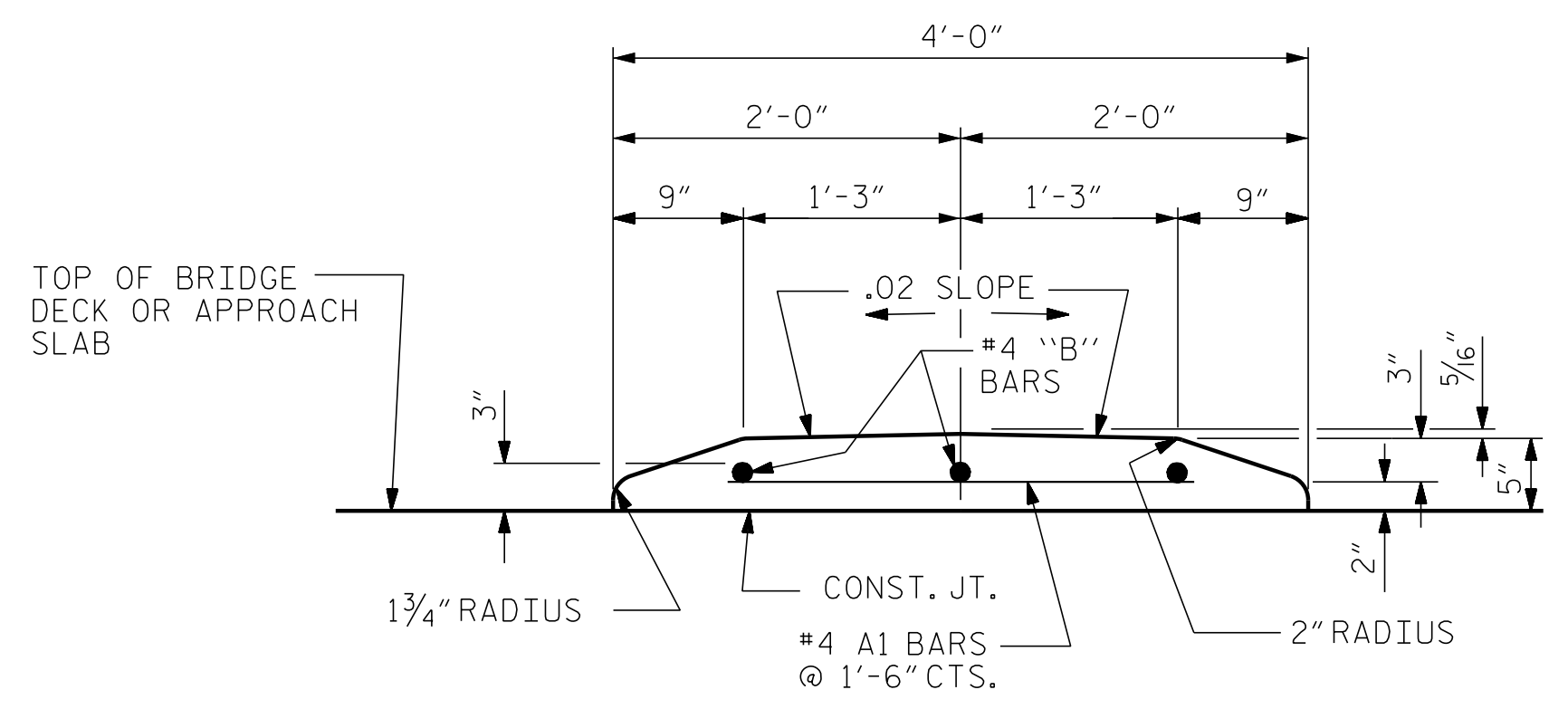

SECTION THRU CONCRETE MEDIAN

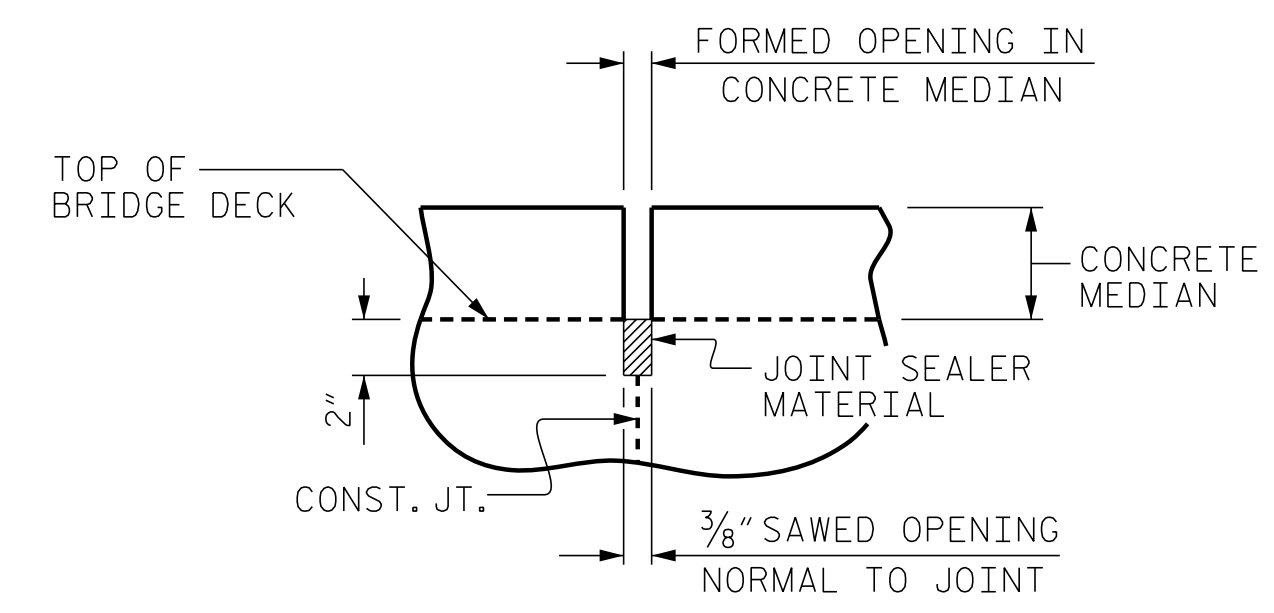

SECTION A-A

PROJECT NO. R-5311A
 HERTFORD COUNTY
 STATION: 50+99.00 -Y2-

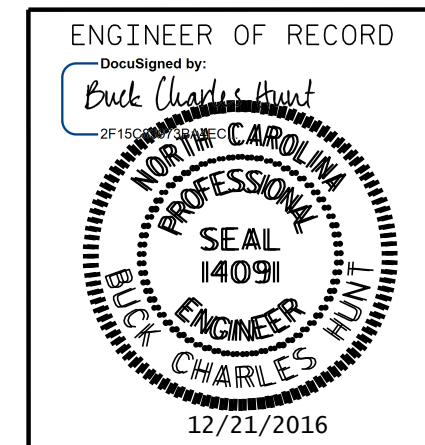

STATE OF NORTH CAROLINA
 DEPARTMENT OF TRANSPORTATION
 RALEIGH
 SUPERSTRUCTURE
 CONCRETE MEDIAN

1223 Jones Franklin Rd.
 Raleigh, N.C. 27606
 Bus: 919 851 8077
 Fax: 919 851 8107
 LICENSE NO. F-0377

| REVISIONS | | | | | | SHEET NO. |
|-----------|-----|-------|-----|-----|-------|--------------|
| NO. | BY: | DATE: | NO. | BY: | DATE: | TOTAL SHEETS |
| 1 | | | 3 | | | 61 |
| 2 | | | 4 | | | |

DOCUMENT NOT CONSIDERED FINAL
 UNLESS ALL SIGNATURES COMPLETED

P:\2015\A-5311A\Structures\Str 2 -Y2-UGMR-5311A_STR_Y2_BR.dgn
 12/20/2016 2:25:20 PM

DRAWN BY: D. HODGE DATE: 4/16
 CHECKED BY: B.C. HUNT DATE: 10/16