

### EDI MODEL 2018ECL-NC CONFLICT MONITOR PROGRAMMING DETAIL

(remove jumpers and set switches as shown)

REMOVE DIODE JUMPERS 1-5, 1-6, 1-9, 1-11, 2-5, 2-6, 2-9, 2-11, 4-8, 5-9, 5-11, 6-9, 6-11, and 9-11.

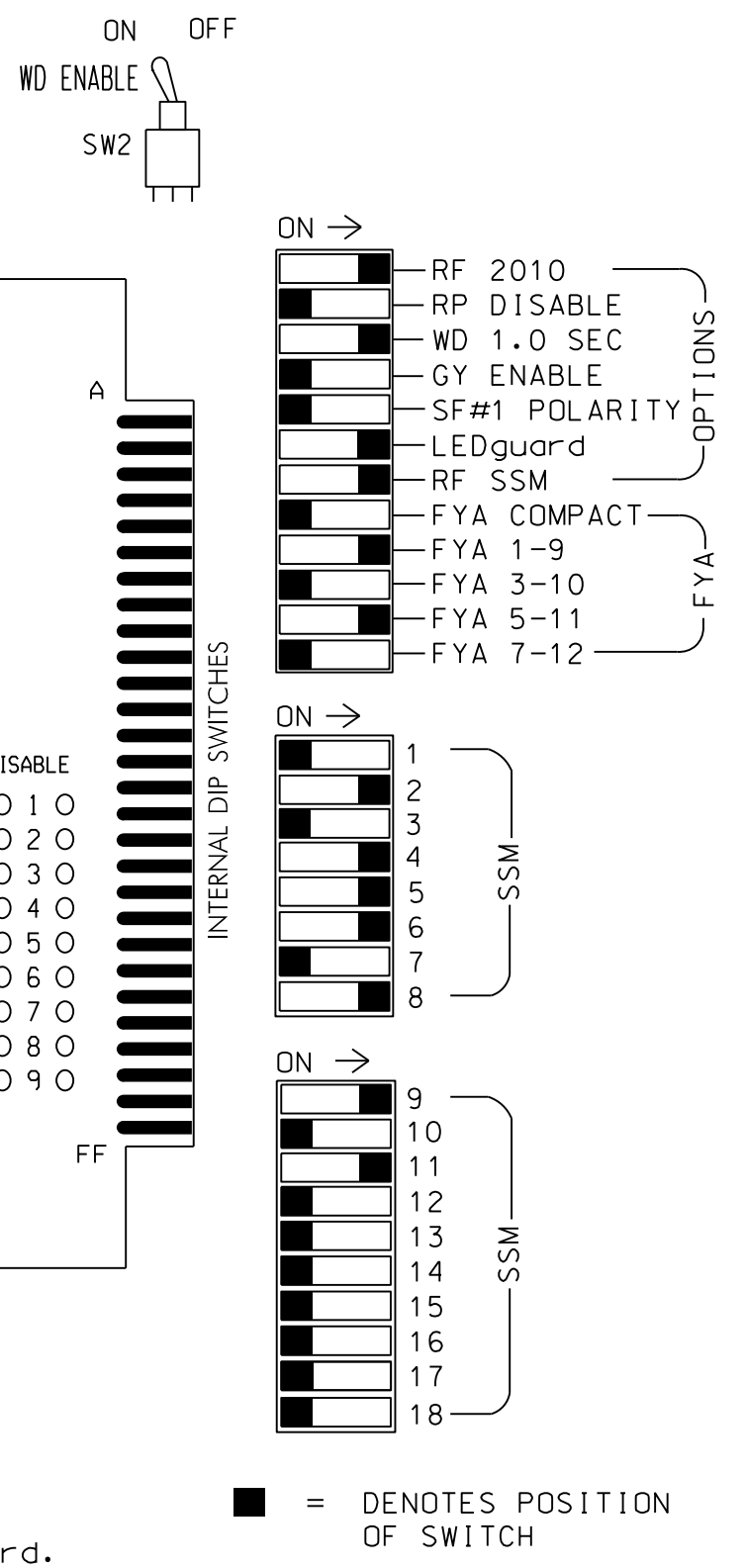
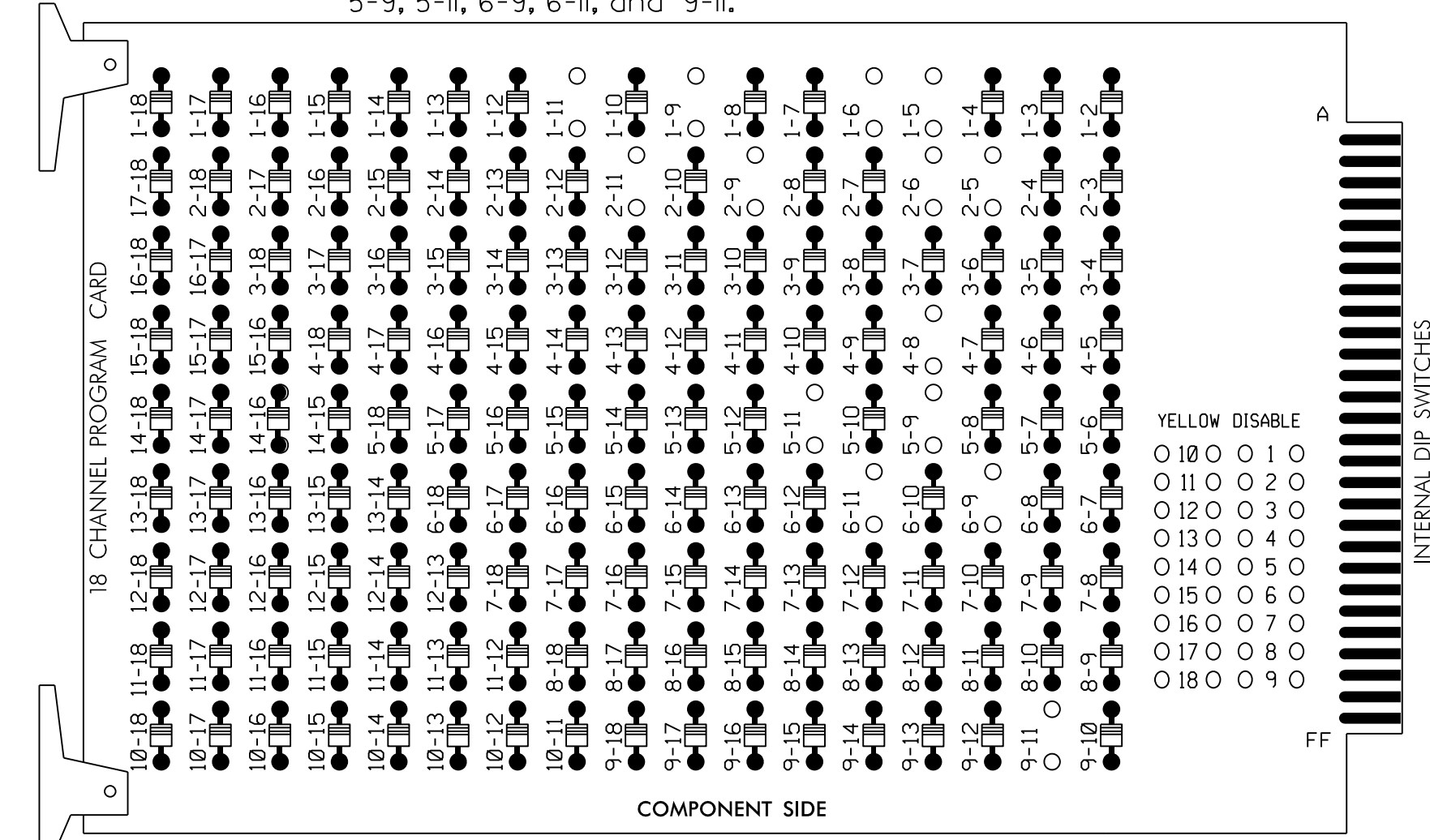

**NOTES:**

1. Card is provided with all diode jumpers in place. Removal of any jumper allows its channels to run concurrently.
2. Ensure jumpers SEL2-SEL5 and SEL9 are present on the monitor board.
3. Ensure that Red Enable is active at all times during normal operation.
4. Connect serial cable from conflict monitor to comm. port 1 of 2070 controller. Ensure conflict monitor communicates with 2070.

### NOTES

1. To prevent "flash-conflict" problems, insert red flash program blocks for all unused vehicle load switches in the output file. The installer shall verify that signal heads flash in accordance with the Signal Plans.
2. Program phases 4 and 8 for Dual Entry.
3. Enable Simultaneous Gap-Out for all phases.
4. Program phases 2 and 6 for Start Up In Green.
5. Program phases 2 and 6 for Yellow Flash and overlap 1 as Wag Overlaps.

### EQUIPMENT INFORMATION

CONTROLLER.....2070  
 CABINET.....332 /W/ AUX  
 SOFTWARE.....ECONOLITE OASIS  
 CABINET MOUNT.....BASE  
 OUTPUT FILE POSITIONS...18 WITH AUX. OUTPUT FILE  
 LOAD SWITCHES USED.....S1,S2,S5,S7,S8,S11,  
 AUX S1,AUX S4.  
 PHASES USED.....1,2,4,5,6,8.  
 OVERLAP "A".....1+2  
 OVERLAP "B".....NOT USED  
 OVERLAP "C".....5+6  
 OVERLAP "D".....NOT USED

### SIGNAL HEAD HOOK-UP CHART

| LOAD SWITCH NO.       | S1  | S2    | S3    | S4 | S5    | S6    | S7 | S8 | S9    | S10 | S11 | S12   | AUX S1 | AUX S2 | AUX S3 | AUX S4 | AUX S5 | AUX S6 |      |      |
|-----------------------|-----|-------|-------|----|-------|-------|----|----|-------|-----|-----|-------|--------|--------|--------|--------|--------|--------|------|------|
| CMU CHANNEL NO.       | 1   | 2     | 13    | 3  | 4     | 14    | 5  | 6  | 15    | 7   | 8   | 16    | 9      | 10     | 17     | 11     | 12     | 18     |      |      |
| PHASE                 | 1   | 2     | 2 PED | 3  | 4     | 4 PED | 5  | 6  | 6 PED | 7   | 8   | 8 PED | OLA    | OLB    | SPARE  | OLC    | OLD    | SPARE  |      |      |
| SIGNAL HEAD NO.       | 11  | 21,22 | NU    | NU | 41,42 | NU    | 51 | 42 | 61,62 | NU  | NU  | 81,82 | 11     | NU     | NU     | 51     | NU     | NU     |      |      |
| RED                   |     | 128   |       |    | 101   |       |    | *  | 134   |     |     | 107   |        |        |        |        |        |        |      |      |
| YELLOW                | *   | 129   |       |    | 102   |       |    |    | 135   |     |     | 108   |        |        |        |        |        |        |      |      |
| GREEN                 |     | 130   |       |    | 103   |       |    |    | 136   |     |     | 109   |        |        |        |        |        |        |      |      |
| RED ARROW             |     |       |       |    |       |       |    |    |       |     |     |       |        |        |        |        |        | A121   | A114 |      |
| YELLOW ARROW          |     |       |       |    |       |       |    |    | 132   |     |     |       |        |        |        |        |        |        | A122 | A115 |
| FLASHING YELLOW ARROW |     |       |       |    |       |       |    |    |       |     |     |       |        |        |        |        |        |        | A123 | A116 |
| GREEN ARROW           | 127 |       |       |    |       |       |    |    |       |     |     |       |        |        |        |        |        |        |      |      |

NU = Not Used  
 \* Denotes install load resistor. See load resistor installation detail this sheet.  
 ★ See pictorial of head wiring in detail below.

### INPUT FILE POSITION LAYOUT

(front view)

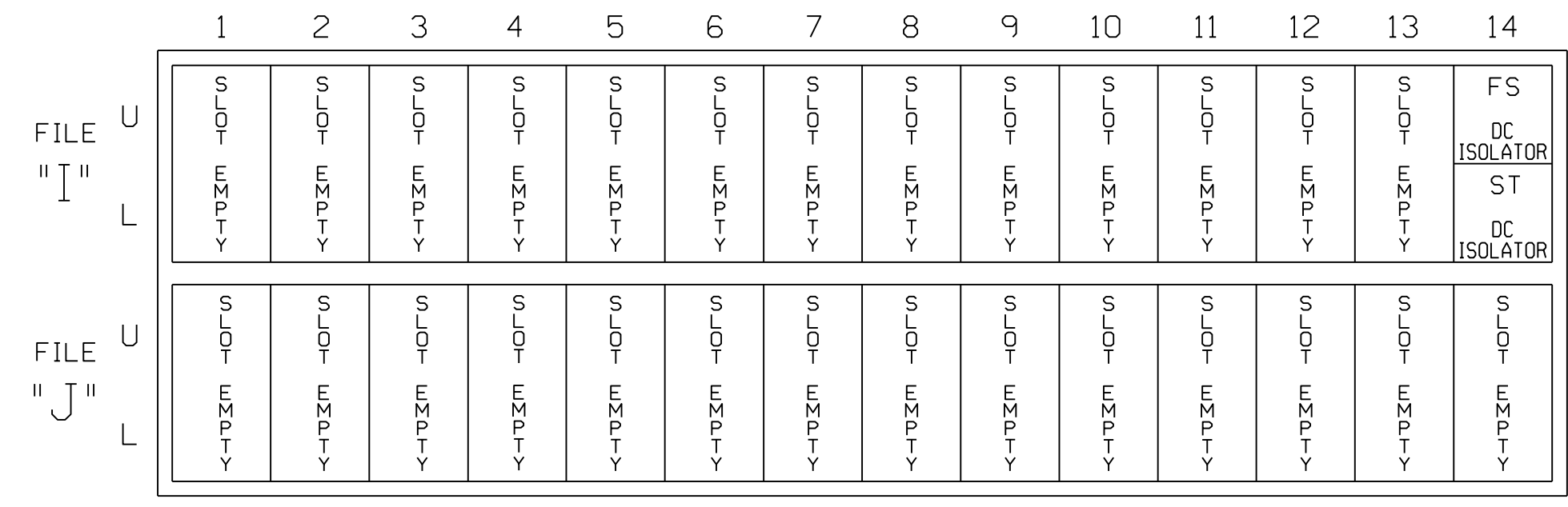

EX.: 1A, 2A, ETC. = LOOP NO.'S

FS = FLASH SENSE  
 ST = STOP TIME

### INPUT FILE POSITION LEGEND: J2L

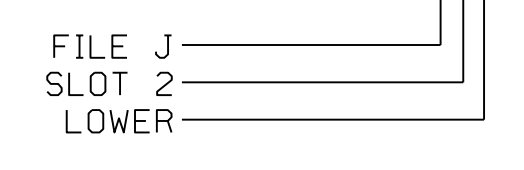

### SPECIAL DETECTOR NOTE

Install a loop emulation detection system for vehicle detection. Perform installation according to manufacturer's directions and NCDOT engineer-approved mounting locations to accomplish the detection schemes shown on the Signal Design Plans.

### 4 SECTION FYA PPLT SIGNAL WIRING DETAIL

(wire signal heads as shown)

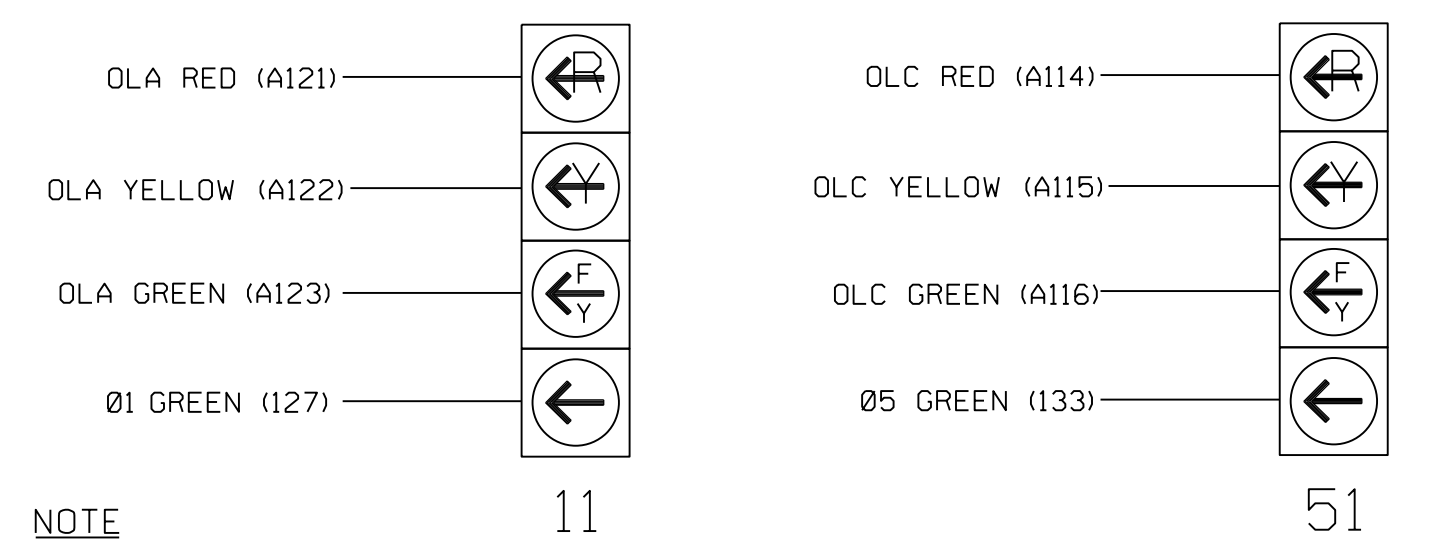

**NOTE**

1. The sequence display for signals #11 & #51 require special logic programming. See sheet 2 for programming instructions.

### LOAD RESISTOR INSTALLATION DETAIL

(install resistors as shown below)

| VALUE (ohms) | WATTAGE   |
|--------------|-----------|
| 1.5K - 1.9K  | 25W (min) |
| 2.0K - 3.0K  | 10W (min) |

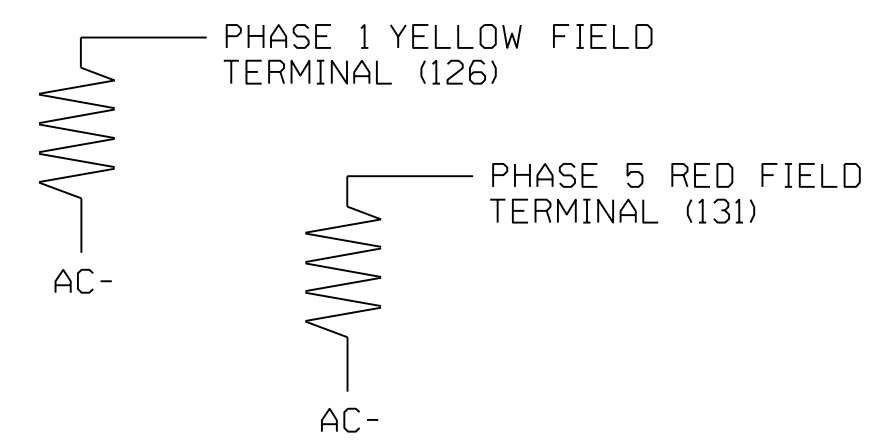

THIS ELECTRICAL DETAIL IS FOR THE SIGNAL DESIGN: 12-0981-T1  
 DESIGNED: July 2016  
 SEALED: 10/4/2016  
 REVISED:



Stantec Consulting Services Inc.  
 801 Jones Franklin Road  
 Suite 300  
 Raleigh, NC 27606  
 Tel. (919) 851-6866  
 Fax. (919) 851-7024  
 www.stantec.com  
 License No. F-0672

Signal Upgrade  
 Temporary Detail 1 - TMP Phases 1 & 01A  
 ELECTRICAL DETAIL SHEET 1 OF 2

DOCUMENT NOT CONSIDERED FINAL UNLESS ALL SIGNATURES COMPLETED

|                                  |  |  |      |
|----------------------------------|--|--|------|
|                                  | NC 273 (Highland St/S.Main St)<br>at<br>S.Main St/<br>Shopping Center Entrance |  |      |
|                                  | Division 12<br>PLAN DATE: JULY 2016<br>PREPARED BY: J. HAMBRIGHT               | Gaston County<br>Mount Holly<br>REVIEWED BY: D. HARRIS<br>REVIEWED BY: B. WATSON |      |
| Prepared for the Offices of:<br> | REVISIONS<br>INIT. DATE  | DocuSigned by:<br>Betty L. Watson 10/4/2016                                      | DATE |