

ADVANCE BEACON OUTPUT ASSIGNMENT PROGRAMMING DETAIL

(program controller as shown below)

FROM MAIN MENU PRESS '6' (OUTPUTS), THEN '1' (OUTPUT ASSIGNMENTS). PRESS '+' UNTIL OUTPUT #33 (PIN 35) IS REACHED.

```

PAGE:1 C1 PIN:35 NOT ENABLED
OUTPUT ASSIGNMENT #.....33
FREQUENCY (0=DEFAULT) (0-25.5 HZ)...1.0
DUTY CYCLE (0=DEFAULT) (0 - 100%)...50
MODE (0=SOLID,1=FLASH).....1
SELECT ASSIGNMENT:
NOT ENABLED.....Y
VEHICLE PHASE.....
PEDESTRIAN PHASE.....
VEHICLE OVERLAP.....
PEDESTRIAN OVERLAP.....
WATCHDOG.....
DETECTOR RESET.....
ADVANCE BEACON.....Y
OUT OF PHASE FLASHER.....
CONTROLLER FLASH.....
RUN FREE.....
RESERVED.....
PREEMPT.....
SOFT PREEMPT.....
ANY PREEMPT.....
COORDINATION PLAN.....
OFFSET.....
PHASE CHECK.....
PHASE ON.....
PHASE NEXT.....
    
```

THE FIRST THREE PROGRAMMING ROWS DEFINE THE OUTPUT TO FLASH, ALONG WITH THE RATE IN WHICH IT WILL FLASH.

THE NOT ENABLED 'Y' WILL REMAIN UNTIL THE FUNCTION OF THIS OUTPUT IS CHANGED. DO NOT ENTER AN 'N'.

```

PAGE:1 C1 PIN:35 NOT ENABLED
SELECT BEACON INDEX (1-4).....1
    
```

WHEN A 'Y' IS ENTERED FOR 'ADVANCE BEACON' THE SCREEN SHOWN ABOVE WILL APPEAR. ENTER DATA AS SHOWN.

PRESS THE 'ENT' KEY AFTER ENTERING DATA, THEN 'ESC'.

DISPLAY WILL NOW SHOW THE SPECIFIED OUTPUT ASSIGNED AS 'ADVANCE BEACON' AS SHOWN BELOW.

```

PAGE:1 C1 PIN:35 ADVANCE BEACON
OUTPUT ASSIGNMENT #.....33
FREQUENCY (0=DEFAULT) (0-25.5 HZ)...1.0
DUTY CYCLE (0=DEFAULT) (0 - 100%)...50
MODE (0=SOLID,1=FLASH).....1
SELECT ASSIGNMENT:
NOT ENABLED.....
VEHICLE PHASE.....
PEDESTRIAN PHASE.....
VEHICLE OVERLAP.....
PEDESTRIAN OVERLAP.....
WATCHDOG.....
DETECTOR RESET.....
ADVANCE BEACON.....Y
OUT OF PHASE FLASHER.....
CONTROLLER FLASH.....
RUN FREE.....
RESERVED.....
PREEMPT.....
SOFT PREEMPT.....
ANY PREEMPT.....
COORDINATION PLAN.....
OFFSET.....
PHASE CHECK.....
PHASE ON.....
PHASE NEXT.....
    
```

FROM MAIN MENU PRESS '6' (OUTPUTS), THEN '1' (OUTPUT ASSIGNMENTS). PRESS '+' UNTIL OUTPUT #34 (PIN 36) IS REACHED.

```

PAGE:1 C1 PIN:36 NOT ENABLED
OUTPUT ASSIGNMENT #.....34
FREQUENCY (0=DEFAULT) (0-25.5 HZ)...0.0
DUTY CYCLE (0=DEFAULT) (0 - 100%)...0
MODE (0=SOLID,1=FLASH).....0
SELECT ASSIGNMENT:
NOT ENABLED.....Y
VEHICLE PHASE.....
PEDESTRIAN PHASE.....
VEHICLE OVERLAP.....
PEDESTRIAN OVERLAP.....
WATCHDOG.....
DETECTOR RESET.....
ADVANCE BEACON.....
OUT OF PHASE FLASHER.....Y
CONTROLLER FLASH.....
RUN FREE.....
RESERVED.....
PREEMPT.....
SOFT PREEMPT.....
ANY PREEMPT.....
COORDINATION PLAN.....
OFFSET.....
PHASE CHECK.....
PHASE ON.....
PHASE NEXT.....
    
```

THE NOT ENABLED 'Y' WILL REMAIN UNTIL THE FUNCTION OF THIS OUTPUT IS CHANGED. DO NOT ENTER AN 'N'.

```

PAGE:1 C1 PIN:36 NOT ENABLED
SELECT OUTPUT ASSIGNMENT (1-64).....33
    
```

WHEN A 'Y' IS ENTERED FOR 'OUT OF PHASE FLASHER' THE SCREEN SHOWN ABOVE WILL APPEAR. ENTER DATA AS SHOWN.

PRESS THE 'ENT' KEY AFTER ENTERING DATA, THEN 'ESC'.

DISPLAY WILL NOW SHOW THE SPECIFIED OUTPUT ASSIGNED AS 'OUT OF PHASE FLASHER' AS SHOWN BELOW.

```

PAGE:1 C1 PIN:36 OUT OF PHASE FLASHER
OUTPUT ASSIGNMENT #.....34
FREQUENCY (0=DEFAULT) (0-25.5 HZ)...0.0
DUTY CYCLE (0=DEFAULT) (0 - 100%)...0
MODE (0=SOLID,1=FLASH).....0
SELECT ASSIGNMENT:
NOT ENABLED.....
VEHICLE PHASE.....
PEDESTRIAN PHASE.....
VEHICLE OVERLAP.....
PEDESTRIAN OVERLAP.....
WATCHDOG.....
DETECTOR RESET.....
ADVANCE BEACON.....
OUT OF PHASE FLASHER.....Y
CONTROLLER FLASH.....
RUN FREE.....
RESERVED.....
PREEMPT.....
SOFT PREEMPT.....
ANY PREEMPT.....
COORDINATION PLAN.....
OFFSET.....
PHASE CHECK.....
PHASE ON.....
PHASE NEXT.....
    
```

OUTPUT REFERENCE SCHEDULE	
OUTPUT 33 =	Ø 2 Ped Yellow
OUTPUT 34 =	Ø 6 Ped Yellow

ADVANCE BEACON WIRING DETAIL

(wire flashers as shown below)

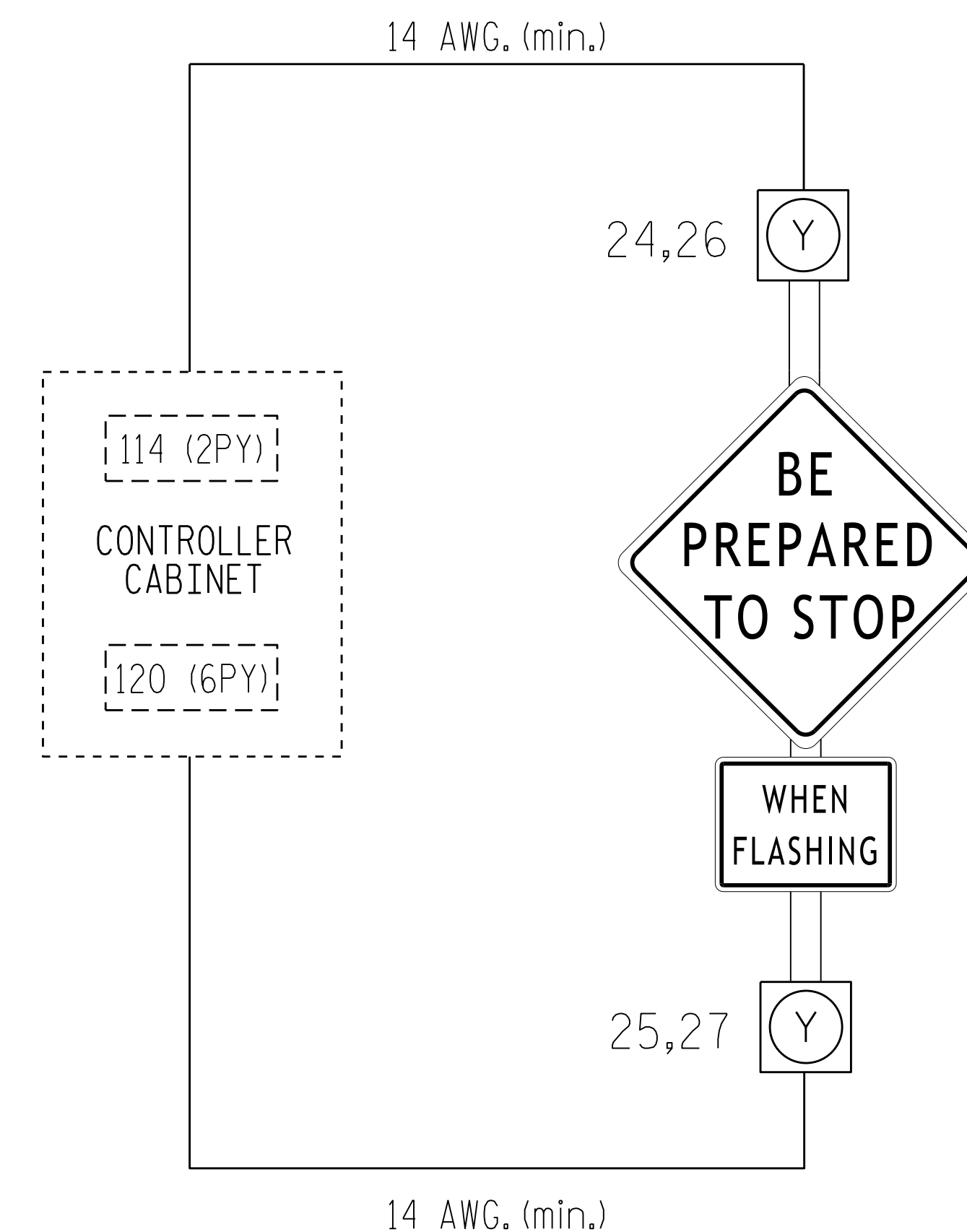

IMPORTANT

1. REMOVE, TAPE AND LABEL CONFLICT MONITOR WIRES ATTACHED TO THE REAR OF TERMINAL 114 (2PY) AND TERMINAL 120 (6PY).
2. INSERT LOADSWITCH FOR S3 AND S9.
3. MAKE SURE LOAD RESISTORS ARE IN PLACE AS SHOWN IN LOAD RESISTOR INSTALLATION DETAIL ON THIS SHEET.
4. TO ACTIVATE SIGN OPERATION AS INDICATED ON THE SIGNAL PLANS, REASSIGN OUTPUT 33 AND 34 AS SHOWN ON THIS SHEET.

LOAD RESISTOR INSTALLATION DETAIL

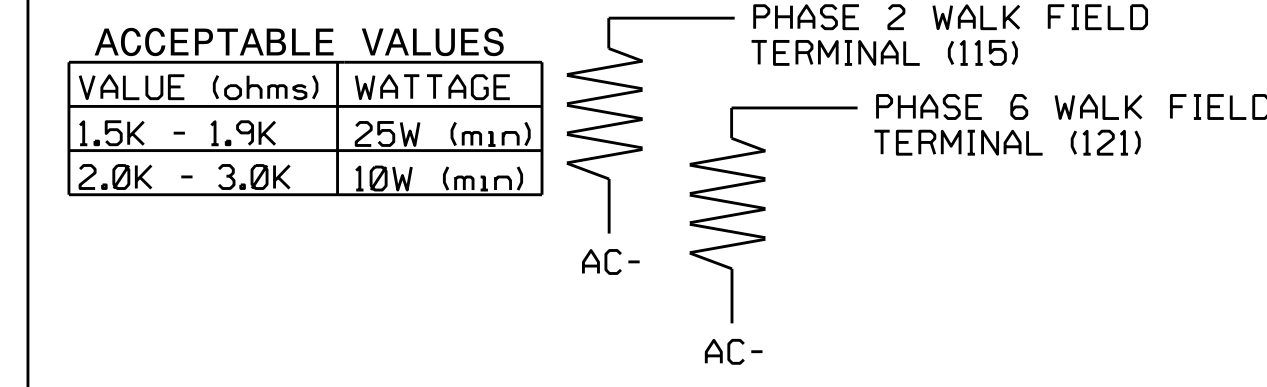

ADVANCE BEACON PROGRAMMING DETAIL

(program controller as shown below)

1. FROM MAIN MENU PRESS '6' (OUTPUTS), THEN '2' (OUTPUT BEACON SETTINGS).

```

          OUTPUT BEACON SETTINGS
TRIGGER PHASES: 12345678910111213141516
BEACON #1 OFF      X
BEACON #2 OFF
BEACON #3 OFF
BEACON #4 OFF
          BEACON   1   2   3   4
OFF DELAY TIME (0-255); 0   0   0   0
ON DELAY TIME (0-255);  0   0   0   0
STOP-TIME HOLD (0-255); 2   0   0   0
    
```

SCROLL DOWN TO VIEW ALL DATA

← NOTICE STOP TIME HOLD

ADVANCE BEACON PROGRAMMING COMPLETE

NOTE: AN OUTPUT HAS TO BE ASSIGNED AS AN ADVANCE BEACON IN ORDER FOR PROPER OPERATION TO OCCUR. SEE OUTPUT ASSIGNMENT DETAIL ON THIS SHEET.

THIS ELECTRICAL DETAIL IS FOR THE SIGNAL DESIGN: 02-0672
DESIGNED: October 2016
SEALED: 2/2/2017
REVISED: N/A

Electrical Detail - Final - Sheet 2 of 2

DOCUMENT NOT CONSIDERED FINAL
UNLESS ALL SIGNATURES COMPLETED

ELECTRICAL AND PROGRAMMING DETAILS FOR:	US 70 at Slocum Road	SEAL 	
Prepared In the Offices of: 750 N. Greenfield Pkwy, Garner, NC 27529	Division 2 Craven County HaveLock PLAN DATE: January 2017 REVIEWED BY: BAS PREPARED BY: S. Armstrong REVIEWED BY:	REVISIONS INIT. DATE	DocuSigned by: Keith M. Minns 2/28/2017 DATE SIG. INVENTORY NO. 02-0672

06-FEB-2017 06:05 S:\ITS\ASUM\ITS_Signals\work\hgr\cdp\sig_Mon\strmstrng\020672_sml.elec.xxx.dgn sarmstrng