

PLAN

NOTES:
 INSTALL THE 4" DIA. DRAIN PIPE THROUGH THE WING WALL AS REQUIRED FOR REINFORCED BRIDGE APPROACH FILLS. SEE THE ROADWAY PLANS. REINFORCING STEEL IN THE WING WALL MAY BE SHIFTED AS NECESSARY TO CLEAR THE DRAIN PIPE.
 #4 D1 BARS MAY BE SHIFTED SLIGHTLY TO AVOID STIRRUPS IN CAP.
 THE UPPER PART OF THE WINGS (POUR #2) SHALL BE POURED AFTER THE SUPERSTRUCTURE.

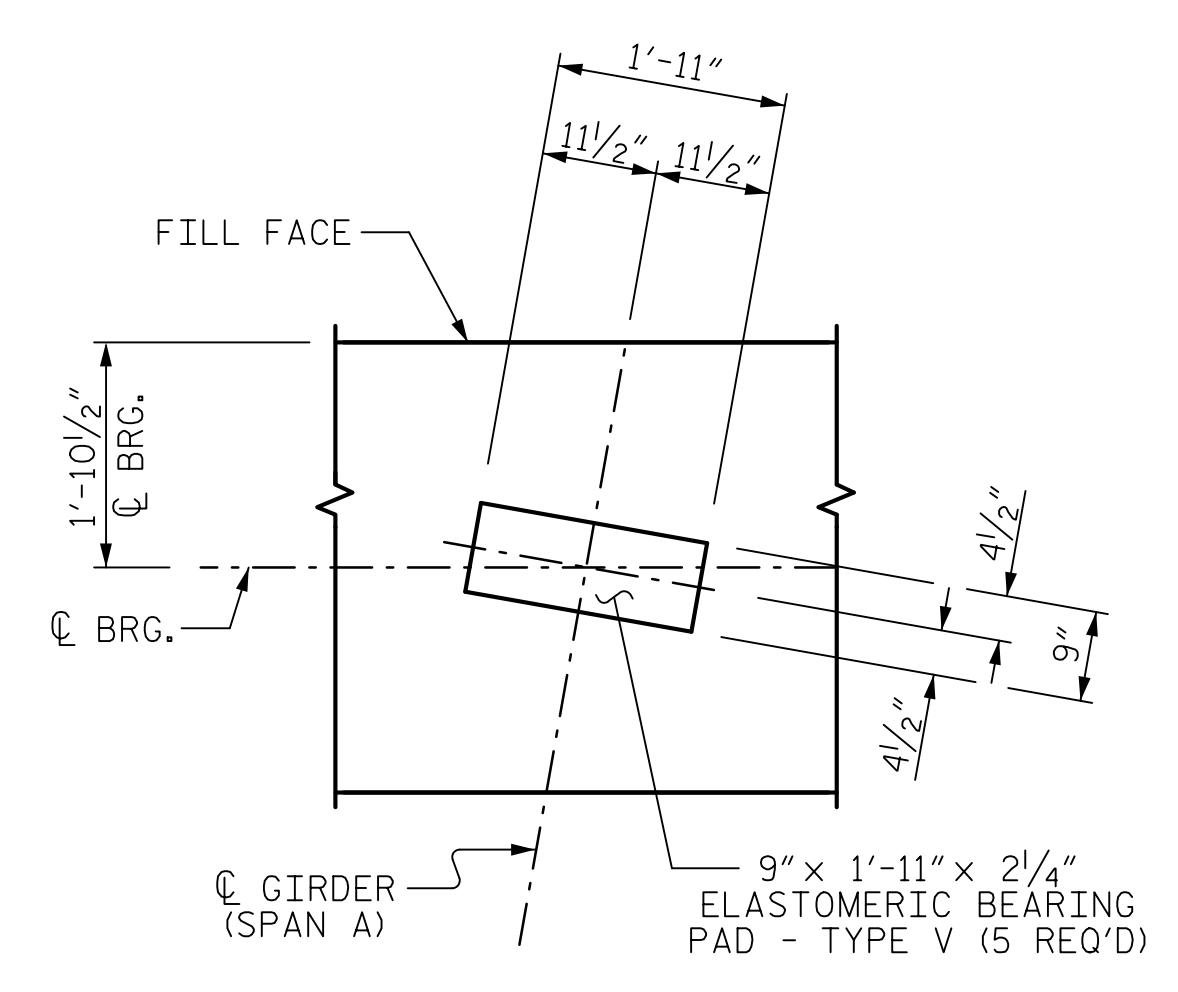

DETAIL "A"
 (TYP. EA. GIRDER)

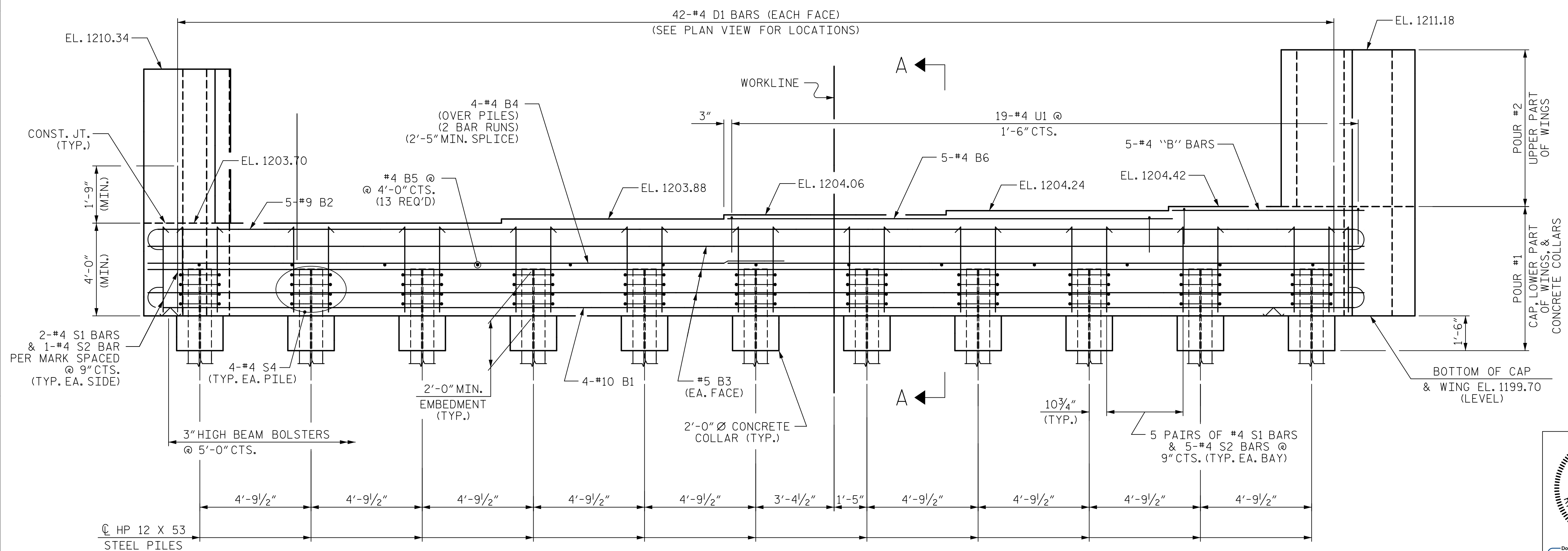

ELEVATION

PROJECT NO. B-4447
 BURKE COUNTY
 STATION: 25+85.40 -L-
 15+67.23 -Y-
 SHEET 1 OF 4

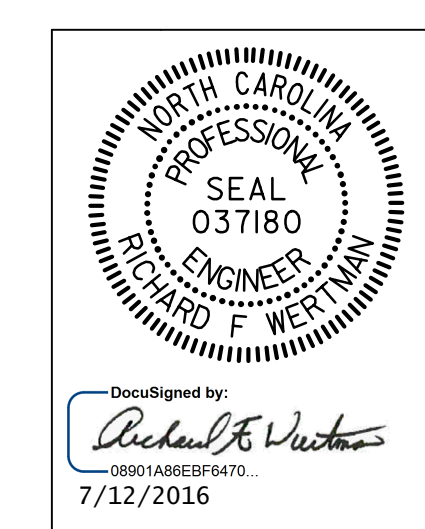

STATE OF NORTH CAROLINA
 DEPARTMENT OF TRANSPORTATION
 RALEIGH
 SUBSTRUCTURE
 INTEGRAL
 END BENT #2
 WESTBOUND LANE

DRAWN BY: T.J. KIRSCHBAUM DATE: 2/2/16
 CHECKED BY: R.F. WERTMAN DATE: 4/6/16
 DESIGN ENGINEER OF RECORD: R.F. WERTMAN DATE: 4/6/16

PLANS PREPARED BY:
Gannett Fleming
 Excellence Delivered As Promised
 2610 Wycliff Road
 Suite 102
 Raleigh, NC 27607-3073
 (919) 420-7660
 NC Lic. No. F-0270

DOCUMENT NOT CONSIDERED FINAL UNLESS ALL SIGNATURES COMPLETED

REVISIONS						SHEET NO.
NO.	BY:	DATE:	NO.	BY:	DATE:	S01-21
1			3			TOTAL SHEETS
2			4			28