

1/6/2017 8:11:11 AM G:\Projects\2014\U-3109A\Structures\Site 2\Site 2-Str 3 Bridge 435 (NBL)\Drawings\Final\403\_U3109A\_smu\_br.dgn

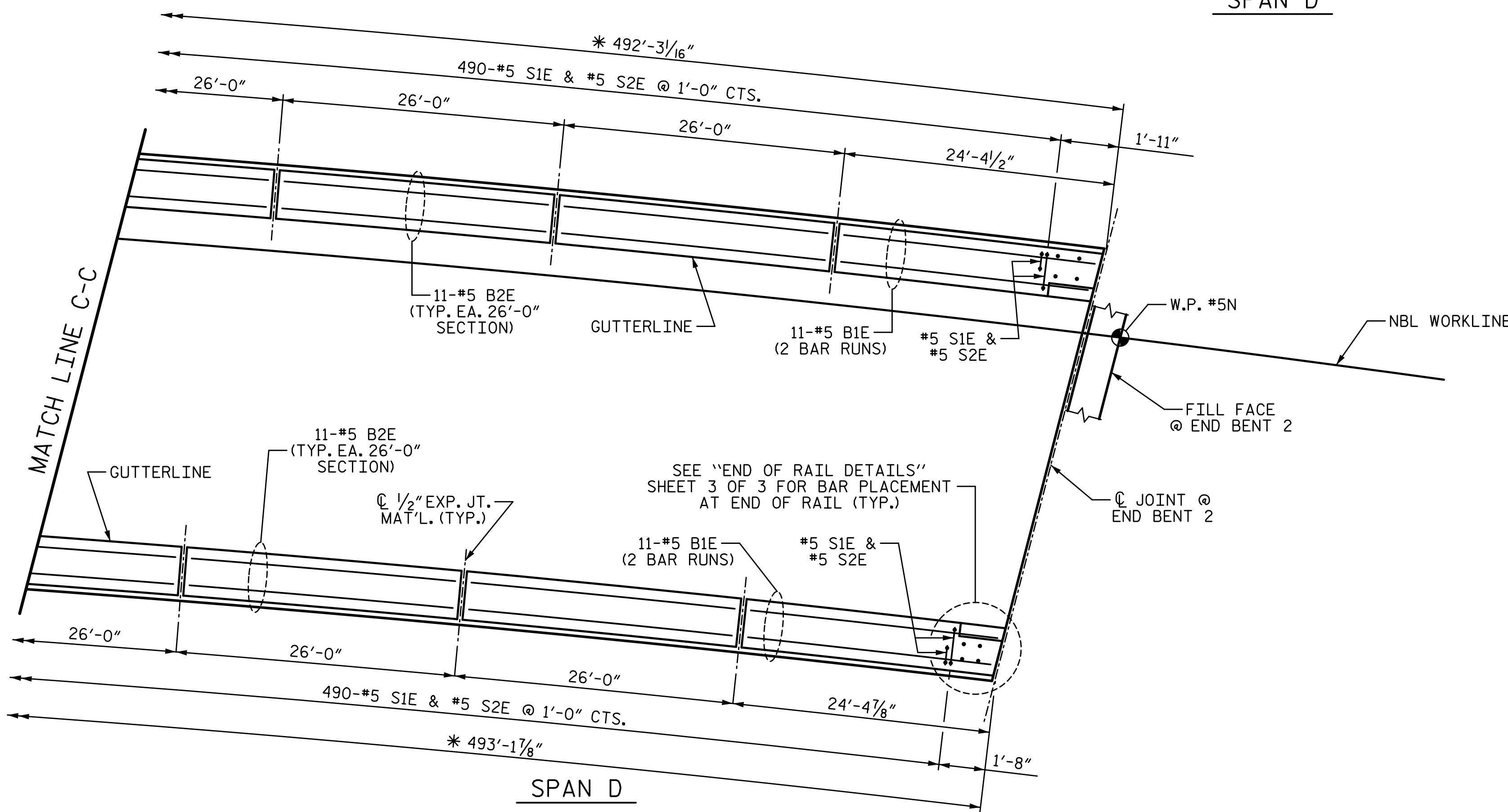
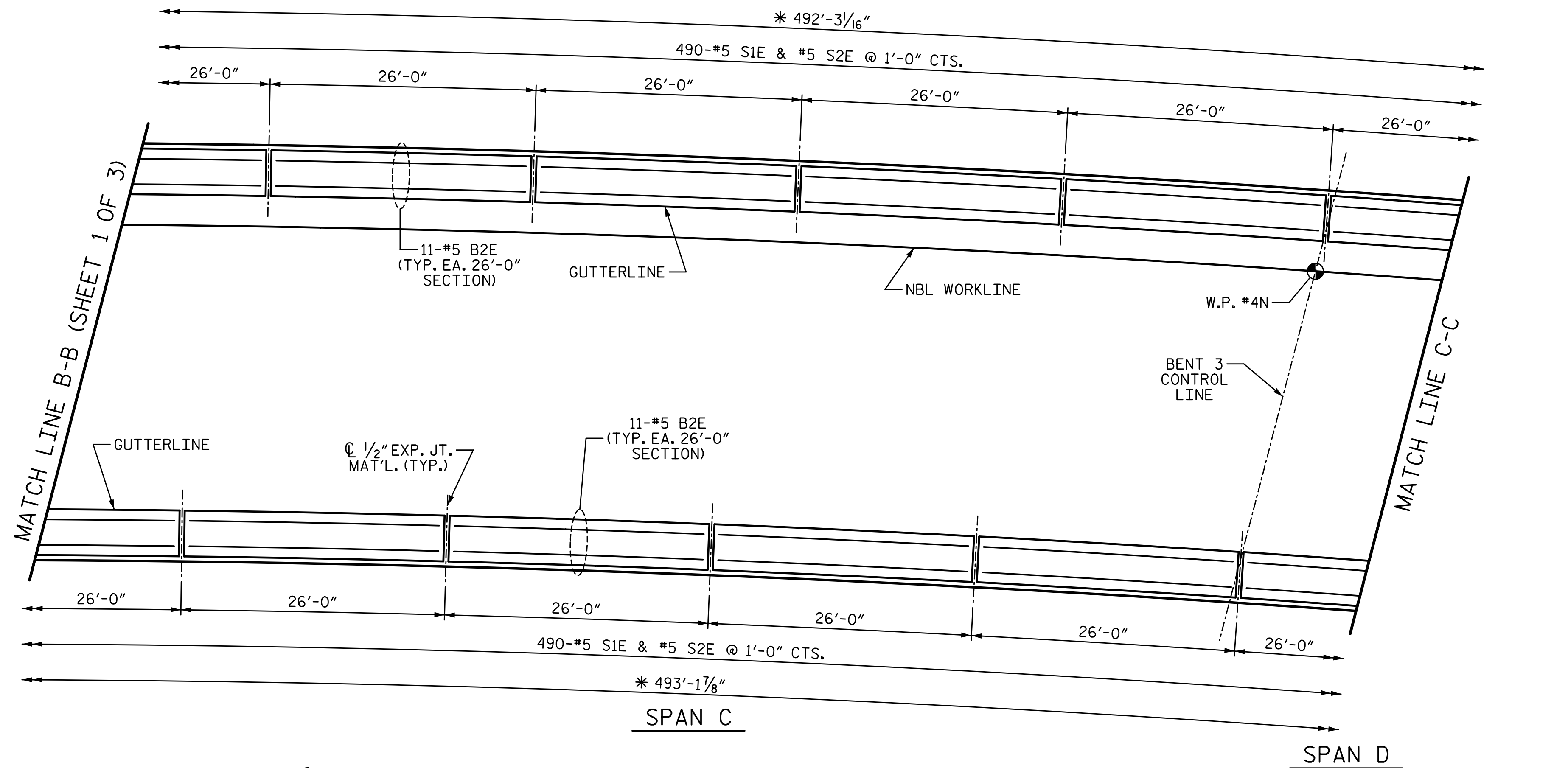

**PART PLAN OF BARRIER RAIL**

ALL DIMENSIONS ARE MEASURED ALONG OUTSIDE FACE OF BARRIER RAIL  
\* @ 60° F

DRAWN BY:	T. BANKOVICH	DATE:	9-15
CHECKED BY:	J.A. BATTS	DATE:	9-15
DESIGN ENGINEER OF RECORD:	J.A. BATTS	DATE:	9-15

PLANS PREPARED BY:  
**SE & A**  
SIMPSON ENGINEERS ASSOCIATES  
5640 Dillard Drive  
Suite 200  
Cary, NC 27518  
(919) 852-0468  
(919) 852-0598 (Fax)  
www.simpsonengr.com  
LICENSURE NO. C-2521

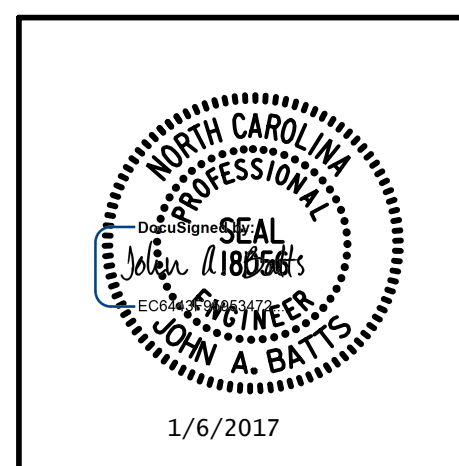

PROJECT NO. U-3109A  
ALAMANCE COUNTY  
STATION: 146+61.35 -L-

SHEET 2 OF 3

STATE OF NORTH CAROLINA DEPARTMENT OF TRANSPORTATION RALEIGH SUPERSTRUCTURE					
<b>CONCRETE BARRIER RAIL</b>					
(NBL)					
REVISIONS					SHEET NO.
NO.	BY:	DATE:	NO.	BY:	DATE:
1			3		
2			4		
TOTAL SHEETS					S03-28
					S03-53

STR. #3