

1/6/2017 8:11:06 AM G:\Projects\2014\U-3109A\Structures\Site 2\Site 2-Str 3 Bridge 435 (NBL)\Drawings\Final\403\_U3109A\_smu\_ts.dgn

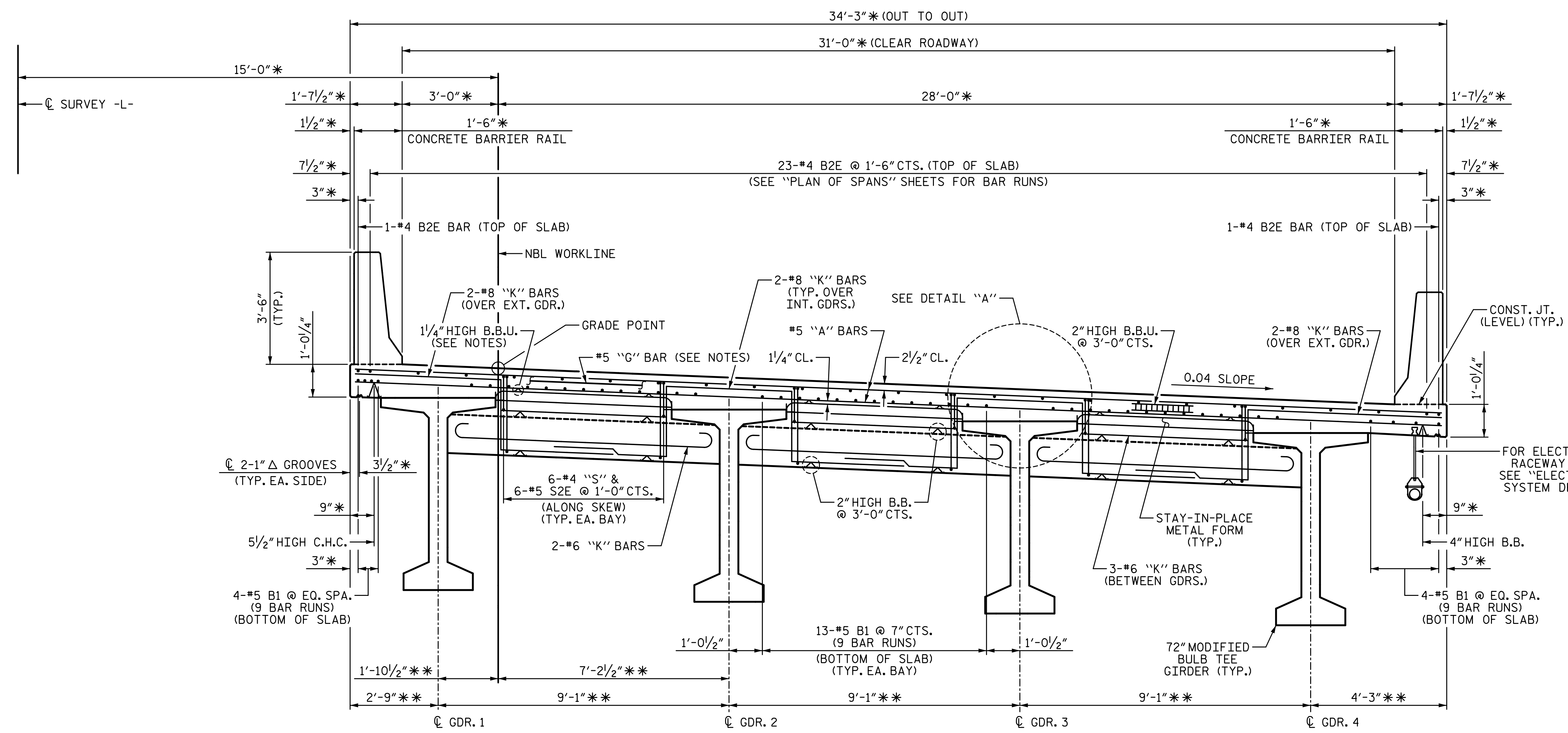

**TYPICAL SECTION**  
(SHOWING END BENT DIAPHRAGMS)

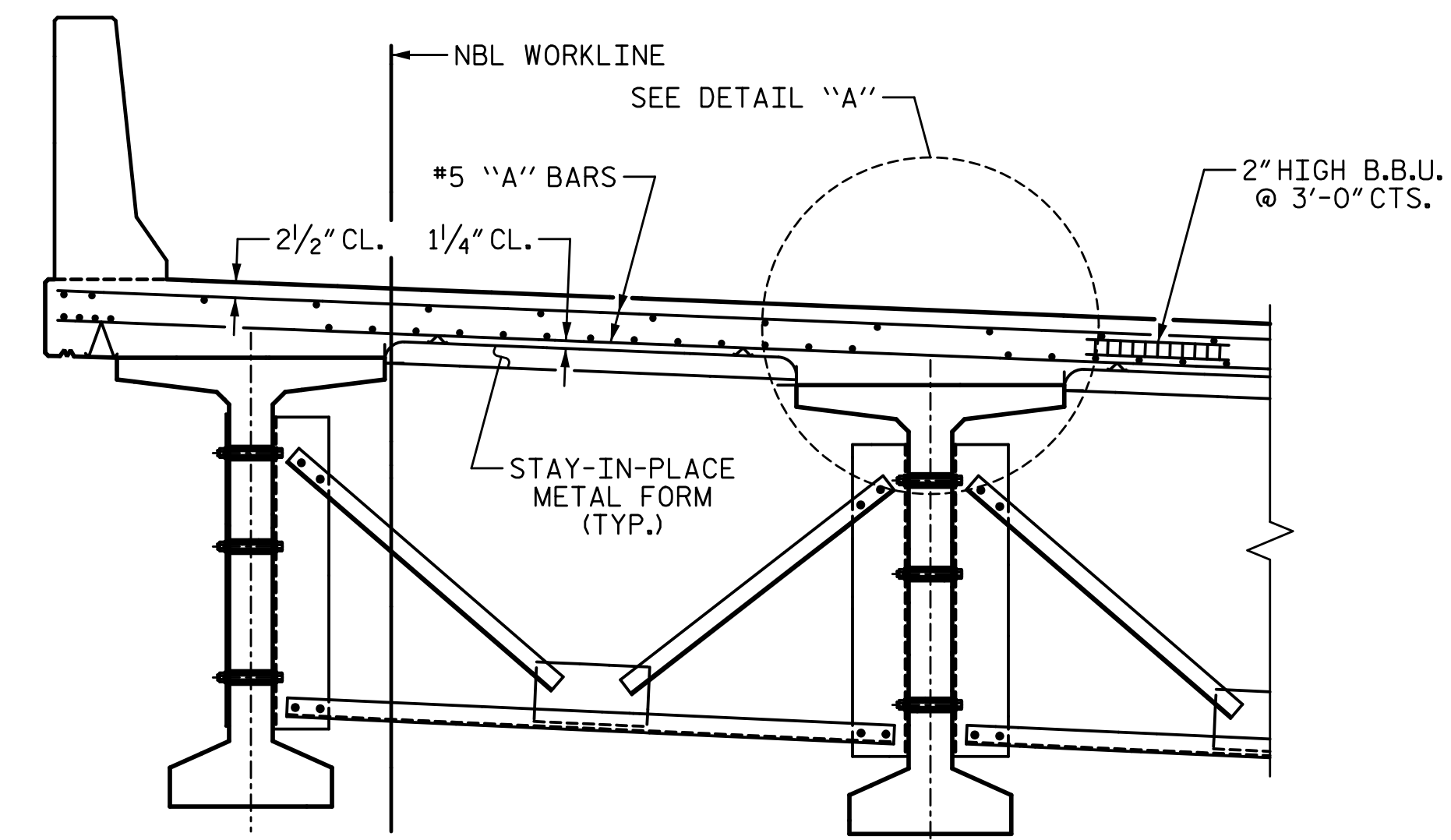

**PARTIAL TYPICAL SECTION**  
(SHOWING INTERMEDIATE DIAPHRAGMS)

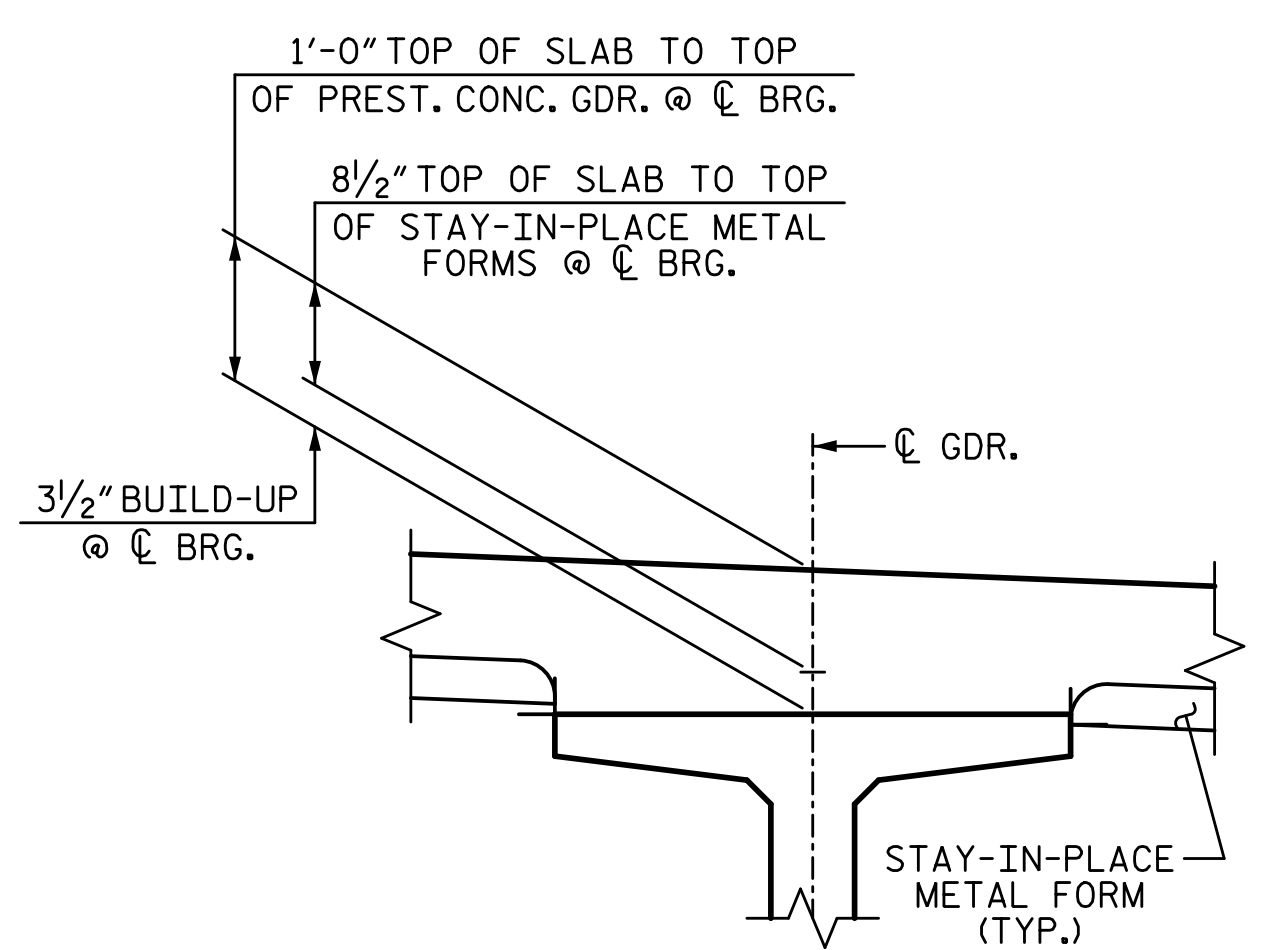

**DETAIL "A"**  
(TYP. EA. GDR.)

**NOTES:**

PROVIDE 1/4" HIGH BEAM BOLSTERS UPPER AT 4'-0" CTS. ATOP THE STAY-IN-PLACE METAL FORMS TO SUPPORT THE BOTTOM MAT OF "A" BARS. WHEN USING REMOVABLE FORMS, PROVIDE CONTINUOUS HIGH CHAIRS FOR METAL DECK (C.H.C.M.) @ 4'-0" CTS. WITH A HEIGHT TO SUPPORT THE BOTTOM MAT OF "A" BARS A CLEAR DISTANCE OF 2 1/2" ABOVE THE TOP OF THE REMOVABLE FORM.

LONGITUDINAL STEEL MAY BE SHIFTED SLIGHTLY, AS NECESSARY, TO AVOID INTERFERENCE WITH STIRRUPS IN PRESTRESSED CONCRETE GIRDERS.

PREVIOUSLY CAST CONCRETE IN A CONTINUOUS UNIT SHALL HAVE ATTAINED A MINIMUM COMPRESSIVE STRENGTH OF 3,000 PSI BEFORE ADDITIONAL CONCRETE IS CAST IN THE UNIT.

BARRIER RAIL IN A CONTINUOUS UNIT SHALL NOT BE CAST UNTIL ALL SLAB CONCRETE IN THE UNIT HAS BEEN CAST AND HAS REACHED A MINIMUM COMPRESSIVE STRENGTH OF 3,000 PSI.

#5 "G" BAR MAY BE SHIFTED SLIGHTLY, AS NECESSARY, TO CLEAR REINFORCING STEEL AND STIRRUPS.

\* RADIAL DIMENSION

\*\* RADIAL THRU W.P.

FOR ELECTRICAL CONDUIT RACEWAY AND HANGERS, SEE "ELECTRICAL CONDUIT SYSTEM DETAILS" SHEETS

PROJECT NO. U-3109A  
ALAMANCE COUNTY  
STATION: 146+61.35 -L-

SHEET 1 OF 3

STATE OF NORTH CAROLINA  
DEPARTMENT OF TRANSPORTATION  
RALEIGH  
SUPERSTRUCTURE

**TYPICAL SECTION**  
(NBL)

REVISIONS						SHEET NO.
NO.	BY:	DATE:	NO.	BY:	DATE:	S03-8
1			3			TOTAL SHEETS
2			4			S03-53

DRAWN BY: <u>T. BANKOVICH</u>	DATE: <u>9-15</u>
CHECKED BY: <u>J.A. BATTS</u>	DATE: <u>9-15</u>
DESIGN ENGINEER OF RECORD: <u>J.A. BATTS</u>	DATE: <u>9-15</u>

PLANS PREPARED BY:  
**SIMPSON ENGINEERS & ASSOCIATES**  
5640 Dillard Drive  
Suite 200  
Cary, NC 27518  
(919) 852-0468  
(919) 852-0598 (Fax)  
www.simpsonengr.com  
LICENSURE NO. C-2521



STR. #3