

9/11/2015 10:16:48 AM G:\Projects\2014\U-3109A\Structures\Site 2\Site 2-Str 2 Bridge 436 (SBL)\Drawings\Final\402_U3109A-smu_bt1.dgn

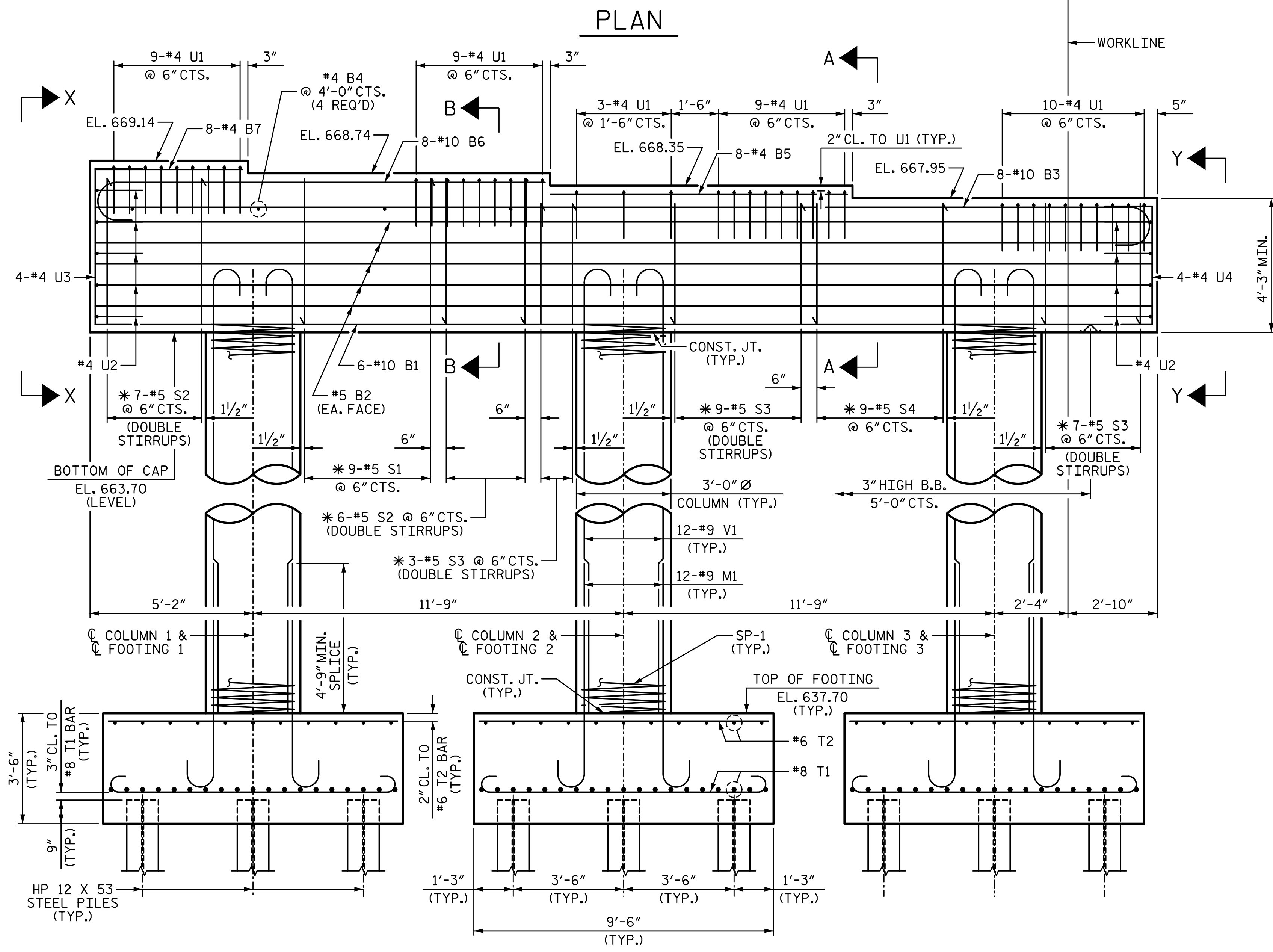

NOTES:

- * INVERT ALTERNATE STIRRUPS.
- STIRRUPS AND "U" BARS IN CAP MAY BE SHIFTED AS NECESSARY TO CLEAR ANCHOR BOLTS.
- HOOKS ON "M" & "V" BARS MAY BE TURNED AS NECESSARY FOR PLACING REINFORCING STEEL.
- FOR PILE SPLICE DETAILS, SEE "END BENT 1" SHEET 3 OF 3.
- SEE GENERAL DRAWING "FOUNDATION LAYOUT" FOR ADDITIONAL NOTES FOR DRIVING PILES.

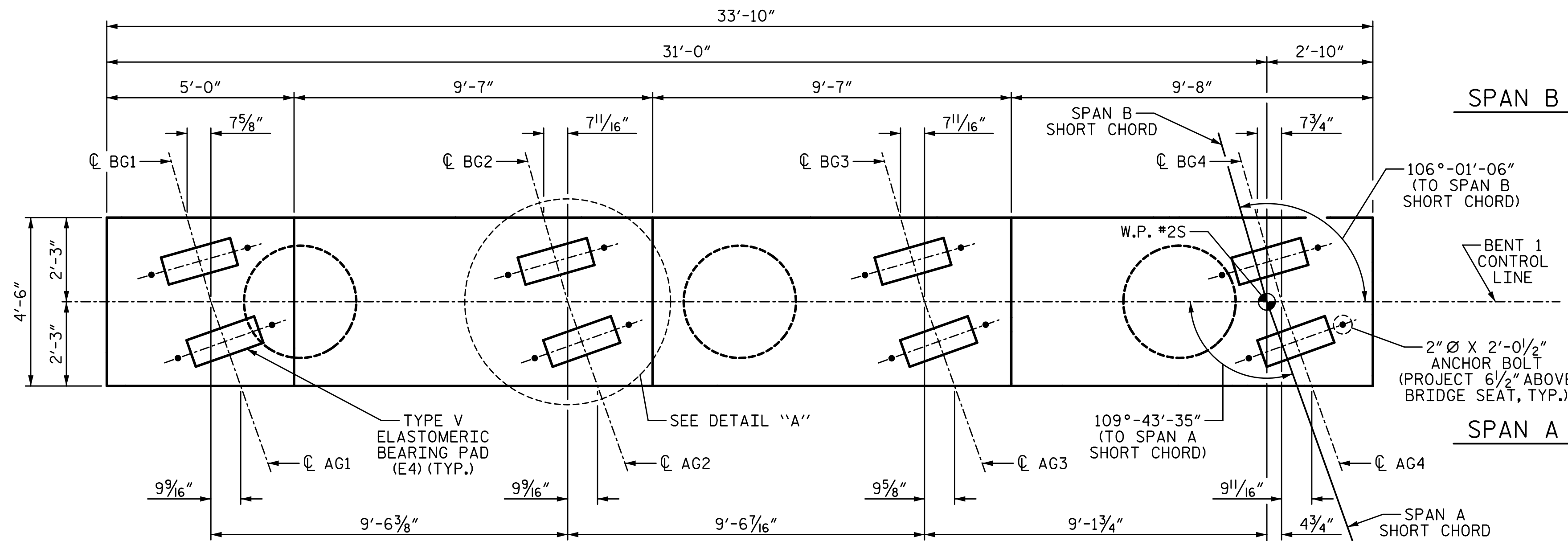
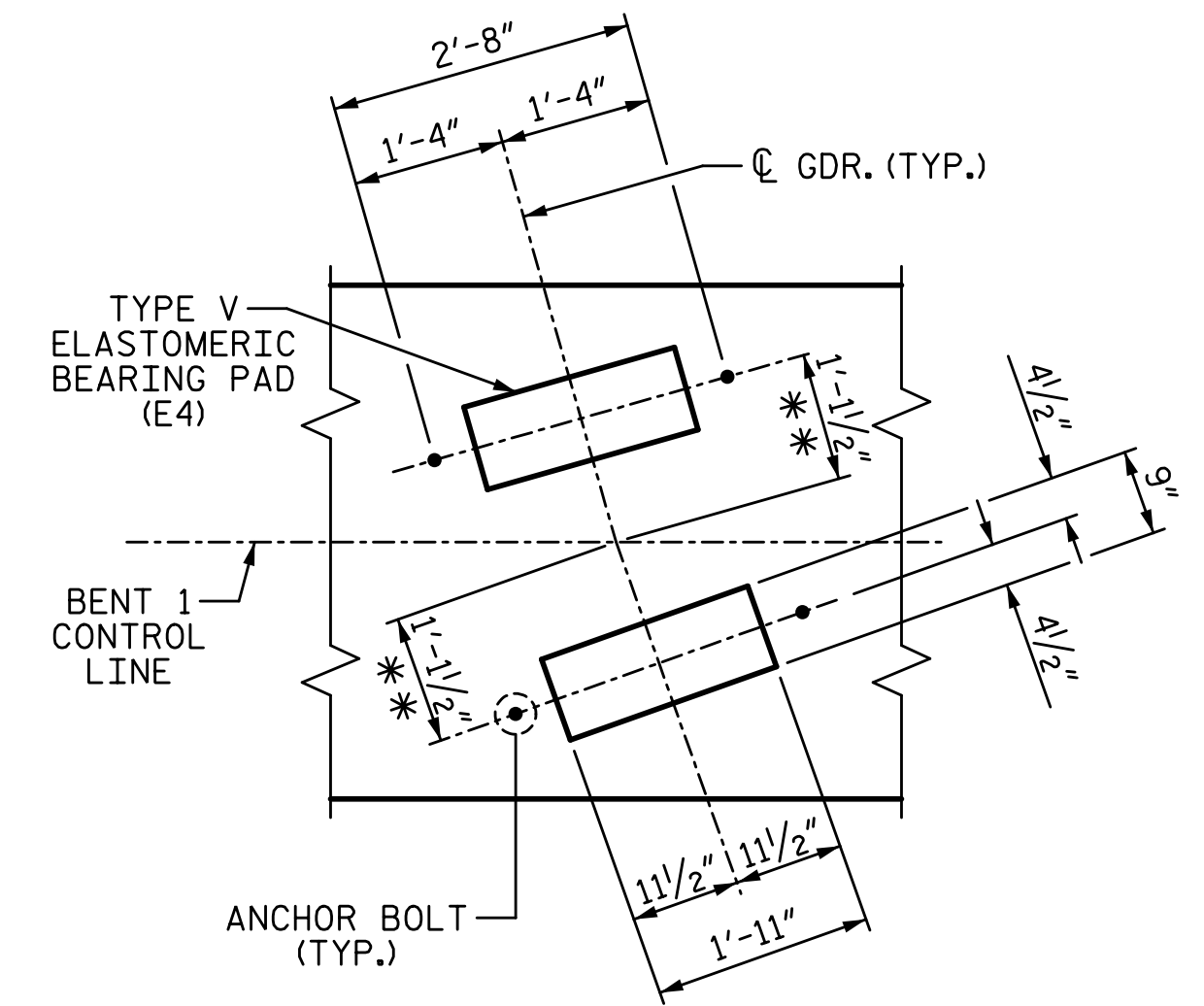

PROJECT NO. U-3109A
ALAMANCE COUNTY
 STATION: 146+61.35 -L-

SHEET 1 OF 2

STATE OF NORTH CAROLINA
 DEPARTMENT OF TRANSPORTATION
 RALEIGH
 SUBSTRUCTURE

BENT 1

(SBL)

PLANS PREPARED BY:

SE & A
 SIMPSON ENGINEERS & ASSOCIATES
 5640 Dillard Drive
 Suite 200
 Cary, NC 27518
 (919) 852-0468
 (919) 852-0598 (Fax)
 www.simpsonengr.com
 LICENSURE NO. C-2521



REVISIONS						SHEET NO. S02-39
NO.	BY:	DATE:	NO.	BY:	DATE:	
1			3			TOTAL SHEETS S02-51
2			4			

DRAWN BY: T. BANKOVICH DATE: 9-15
 CHECKED BY: J.A. BATTS DATE: 9-15
 DESIGN ENGINEER OF RECORD: J.A. BATTS DATE: 9-15

STR. #2