

9/11/2015 10:16:45 AM G:\Projects\2014\U-3109A\Structures\Site 2\Site 2-Str 2 Bridge 436 (SBL)\Drawings\Final\402_U3109A_smu_br.dgn

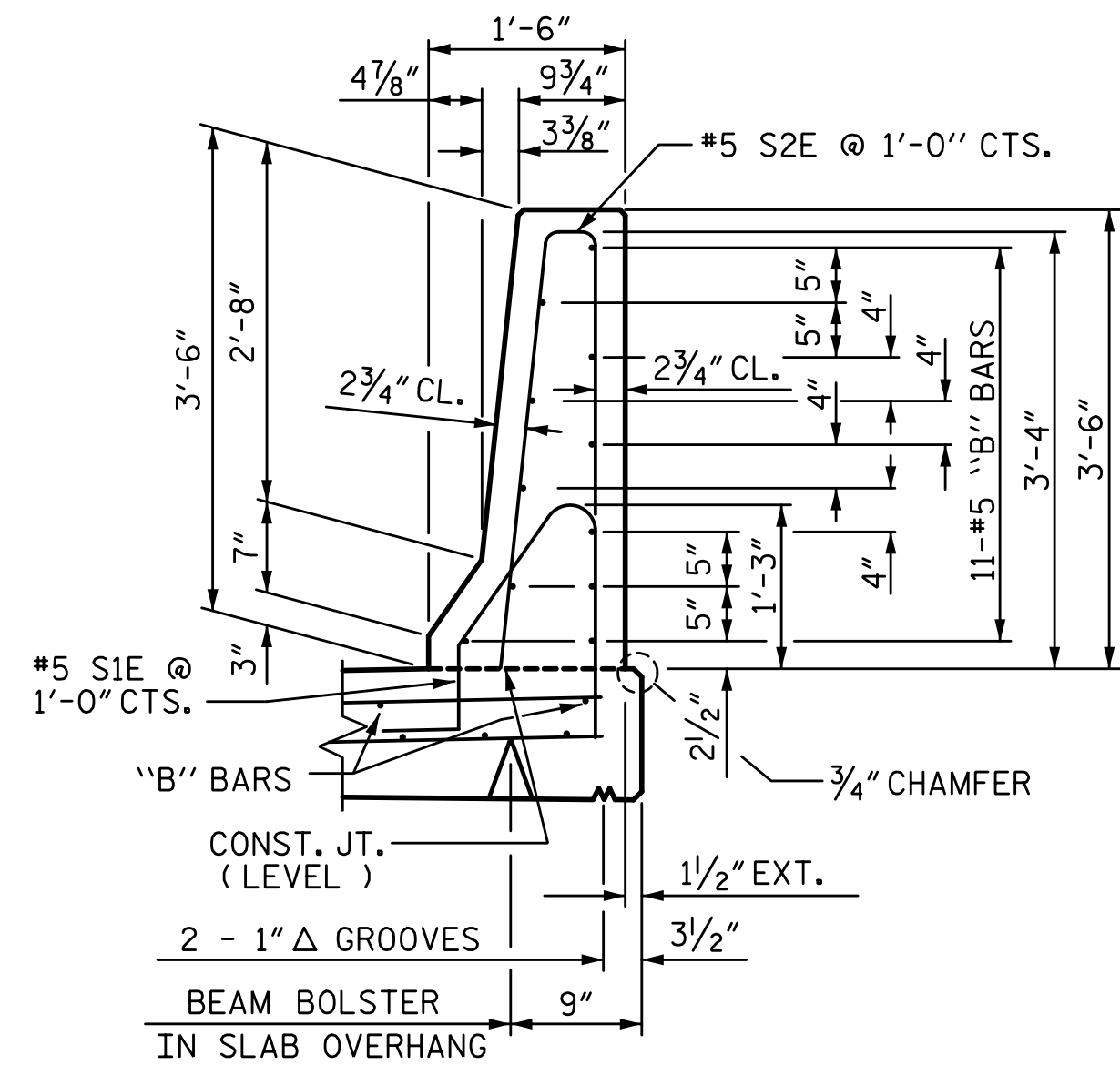

SECTION THRU RAIL

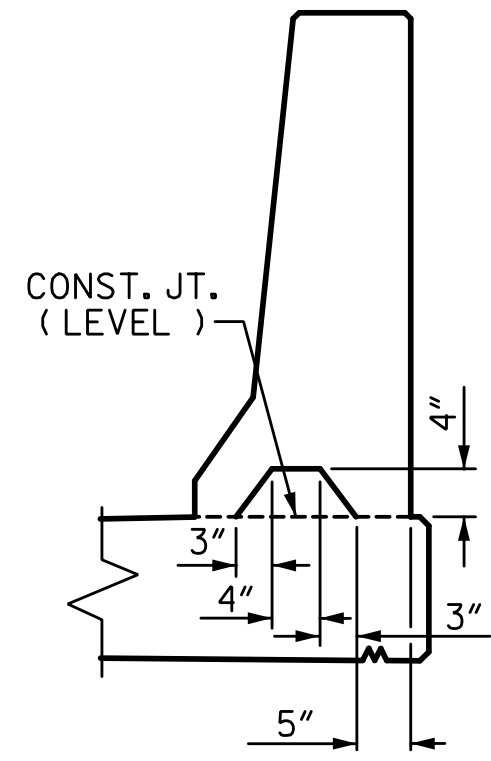

SECTION S-S
AT DAM IN OPEN JOINT
(THIS IS TO BE USED ONLY
WHEN SLIP FORM IS USED)

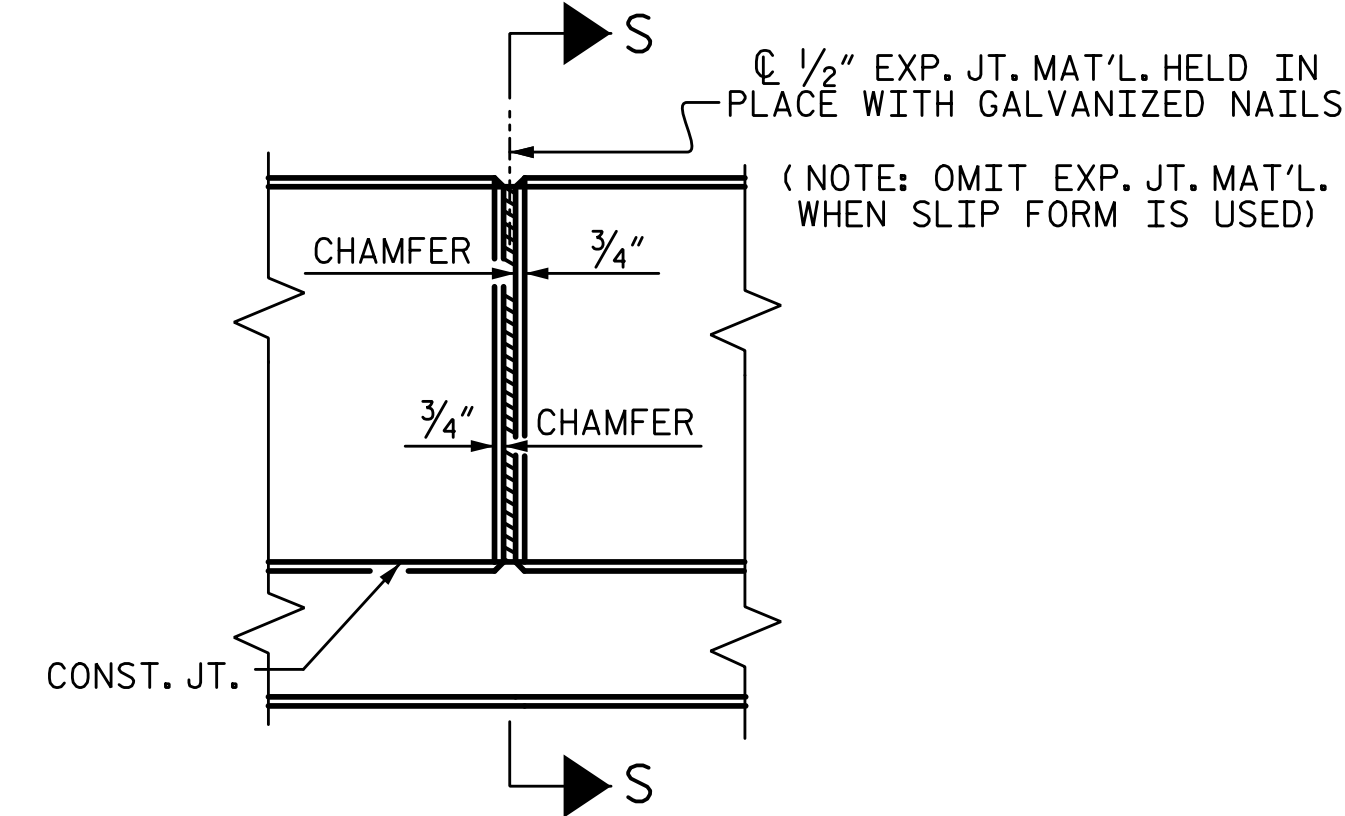

ELEVATION AT EXPANSION JOINTS

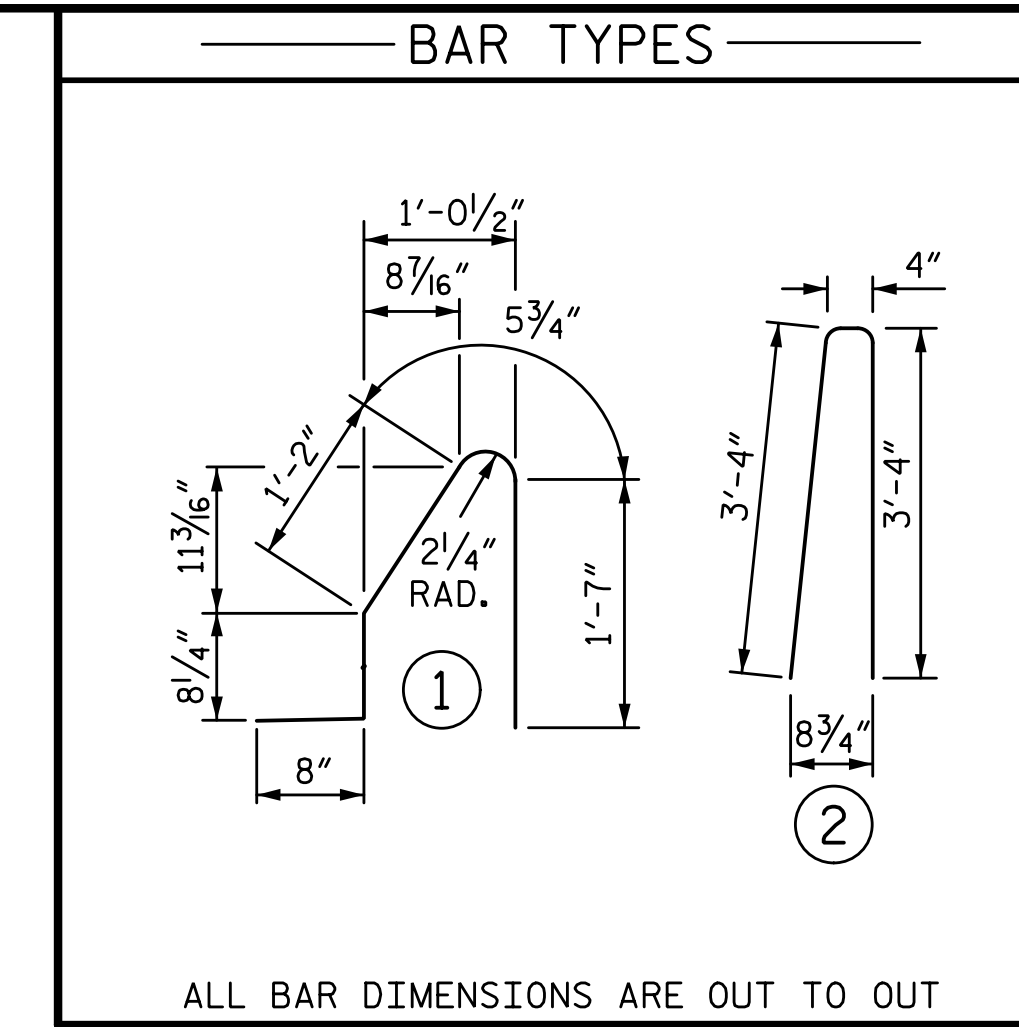

ALL BAR DIMENSIONS ARE OUT TO OUT

BILL OF MATERIAL					
FOR CONCRETE BARRIER RAIL					
BAR	NO.	SIZE	TYPE	LENGTH	WEIGHT
B1E	88	5	STR	14'-7"	1339
B2E	374	5	STR	25'-7"	9980
S1E	978	5	1	4'-7"	4675
S2E	978	5	2	7'-0"	7140
S3E	16	5	STR	4'-0"	67
EPOXY COATED REINFORCING STEEL					23201 LB
CLASS "AA" CONCRETE					133.5 CY
CONCRETE BARRIER RAIL					983.4 LF
"E" INDICATES EPOXY COATED REINFORCING STEEL					

BARRIER RAIL DETAILS

NOTES:

THE BARRIER RAIL IN EACH CONTINUOUS UNIT AND ON APPROACH SLABS SHALL NOT BE CAST UNTIL ALL SLAB CONCRETE IN THAT CONTINUOUS UNIT AND APPROACH SLAB HAS BEEN CAST AND HAS REACHED A MINIMUM COMPRESSIVE STRENGTH OF 3,000 PSI.

ALL REINFORCING STEEL IN BARRIER RAILS SHALL BE EPOXY COATED.

GROOVED CONTRACTION JOINTS, 1/2" IN DEPTH, SHALL BE TOOLED IN ALL EXPOSED FACES OF THE BARRIER RAIL AND IN ACCORDANCE WITH ARTICLE 825-10(B) OF THE STANDARD SPECIFICATIONS. THE CONTRACTION JOINT SHALL BE LOCATED AT EACH THIRD POINT BETWEEN BARRIER RAIL EXPANSION JOINTS. ONLY ONE CONTRACTION JOINT IS REQUIRED AT MIDPOINT OF BARRIER RAIL SEGMENTS LESS THAN 20 FEET IN LENGTH AND NO CONTRACTION JOINTS ARE REQUIRED FOR THOSE SEGMENTS LESS THAN 10 FEET IN LENGTH.

THE #5 S1E AND S2E BARS MAY BE SHIFTED AS NECESSARY TO MAINTAIN A 2" MINIMUM CLEARANCE FROM THE CENTERLINE OF THE EXPANSION JOINTS IN BARRIER RAIL SECTIONS.

FOR DETAILS, QUANTITIES AND LIN. FEET FOR CONCRETE BARRIER RAIL ON APPROACH SLAB, SEE "BRIDGE APPROACH SLAB DETAILS" SHEETS.

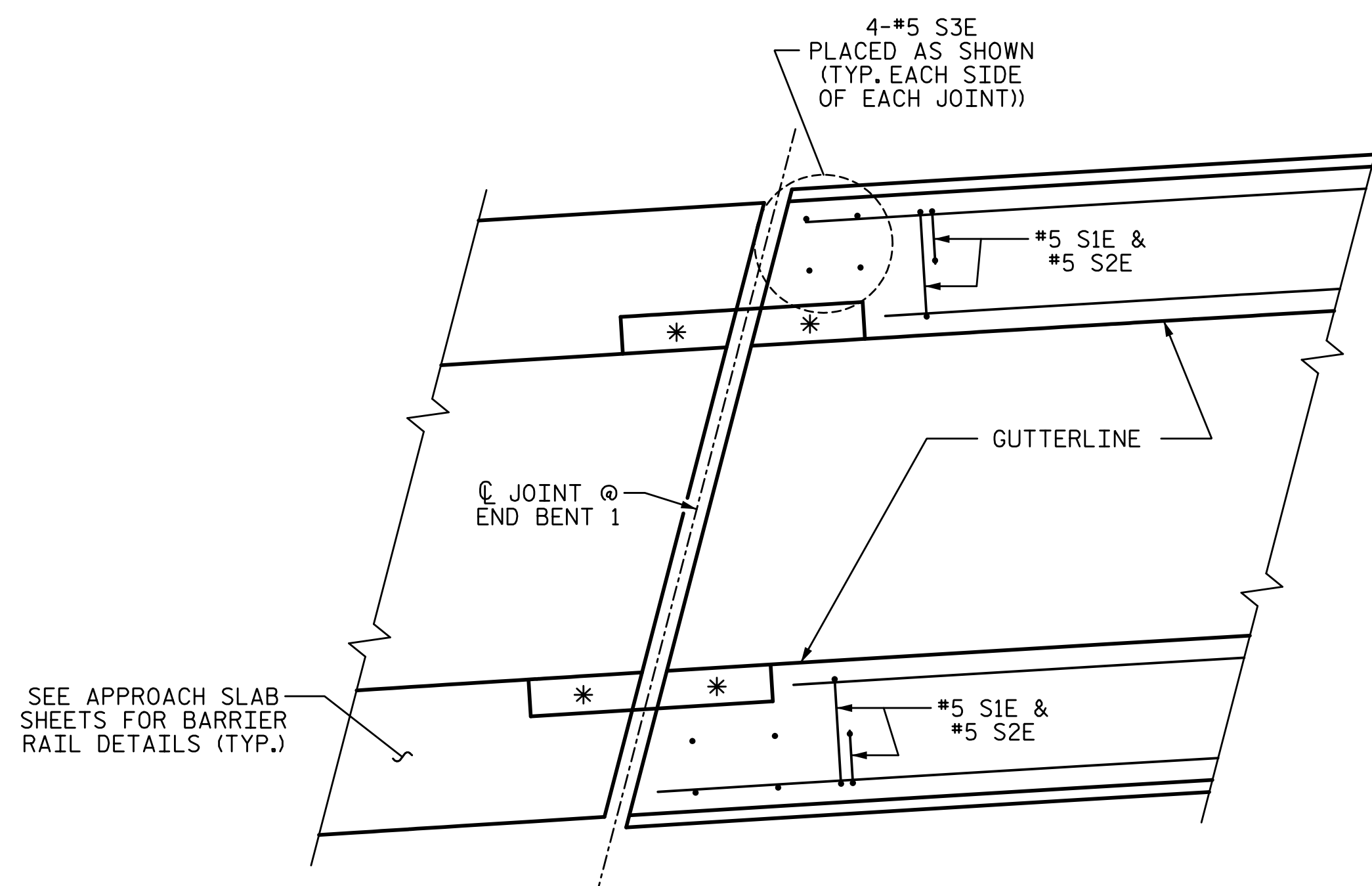

PLAN

(END BENT 1 SHOWN, END BENT 2 SIMILAR)
* FOR BLOCK OUT DETAILS SEE "EXPANSION JOINT SEAL DETAILS FOR BARRIER RAIL" SHEET 2 OF 2

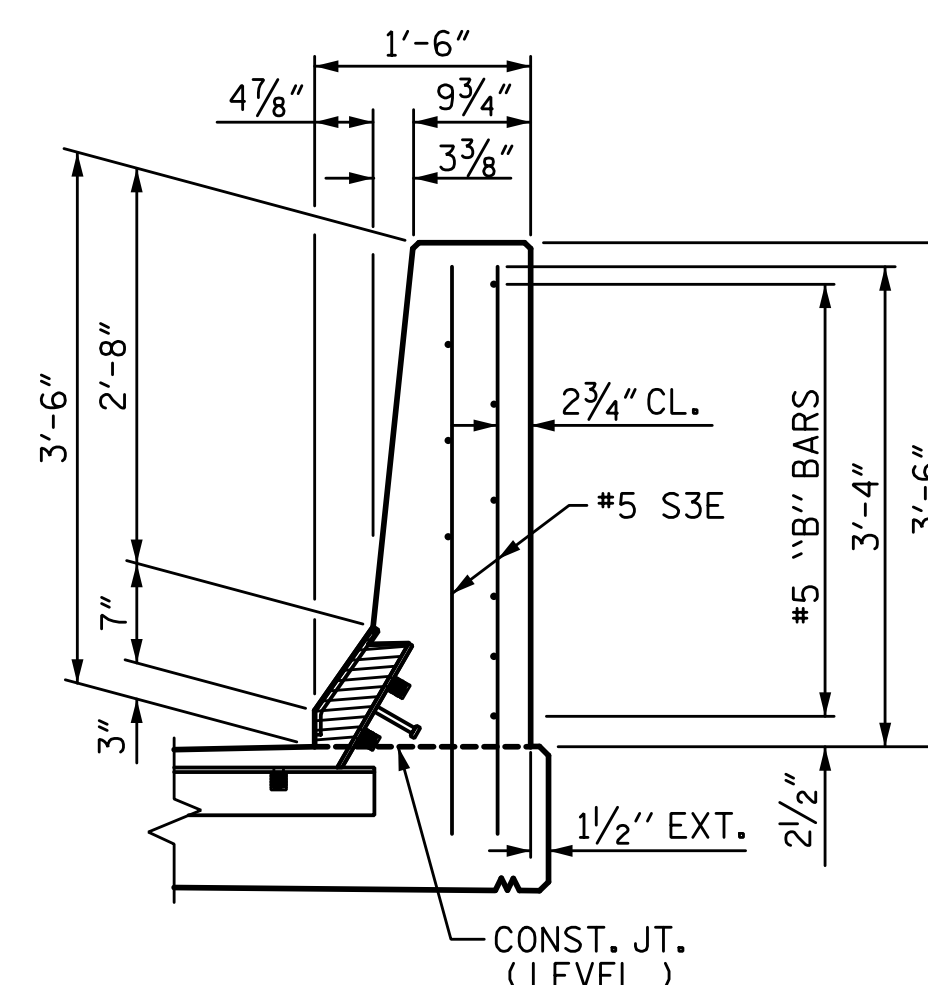

END VIEW @ EXP. JOINTS

END OF RAIL DETAILS @ EXP. JOINTS

DRAWN BY: T. BANKOVICH	DATE: 9-15
CHECKED BY: J.A. BATTS	DATE: 9-15
DESIGN ENGINEER OF RECORD: J.A. BATTS	DATE: 9-15

PLANS PREPARED BY:
SIMPSON ENGINEERS & ASSOCIATES
5640 Dillard Drive
Suite 200
Cary, NC 27518
(919) 852-0468
(919) 852-0598 (Fax)
www.simpsonengr.com
LICENSURE NO. C-2521

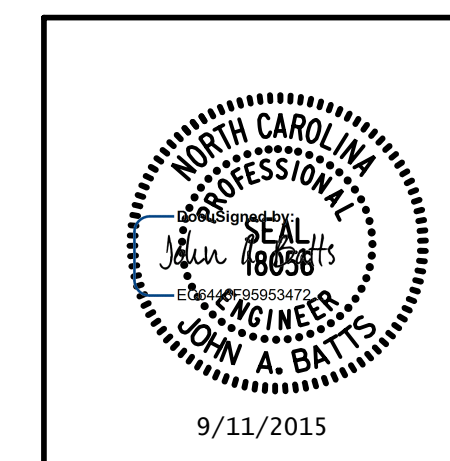

PROJECT NO. U-3109A
ALAMANCE COUNTY
STATION: 146+61.35 -L-

SHEET 3 OF 3

STATE OF NORTH CAROLINA
DEPARTMENT OF TRANSPORTATION
RALEIGH
SUPERSTRUCTURE

CONCRETE
BARRIER RAIL

(SBL)

REVISIONS					
NO.	BY:	DATE:	NO.	BY:	DATE:
1			3		
2			4		

SHEET NO.
S02-29
TOTAL SHEETS
S02-51

STR. #2