

9/11/2015 10:16:42 AM G:\Projects\2014\U-3109A\Structures\Site 2\Site 2-Str 2 Bridge 436 (SBL)\Drawings\Final\402\_U3109A\_smu\_ps.dgn

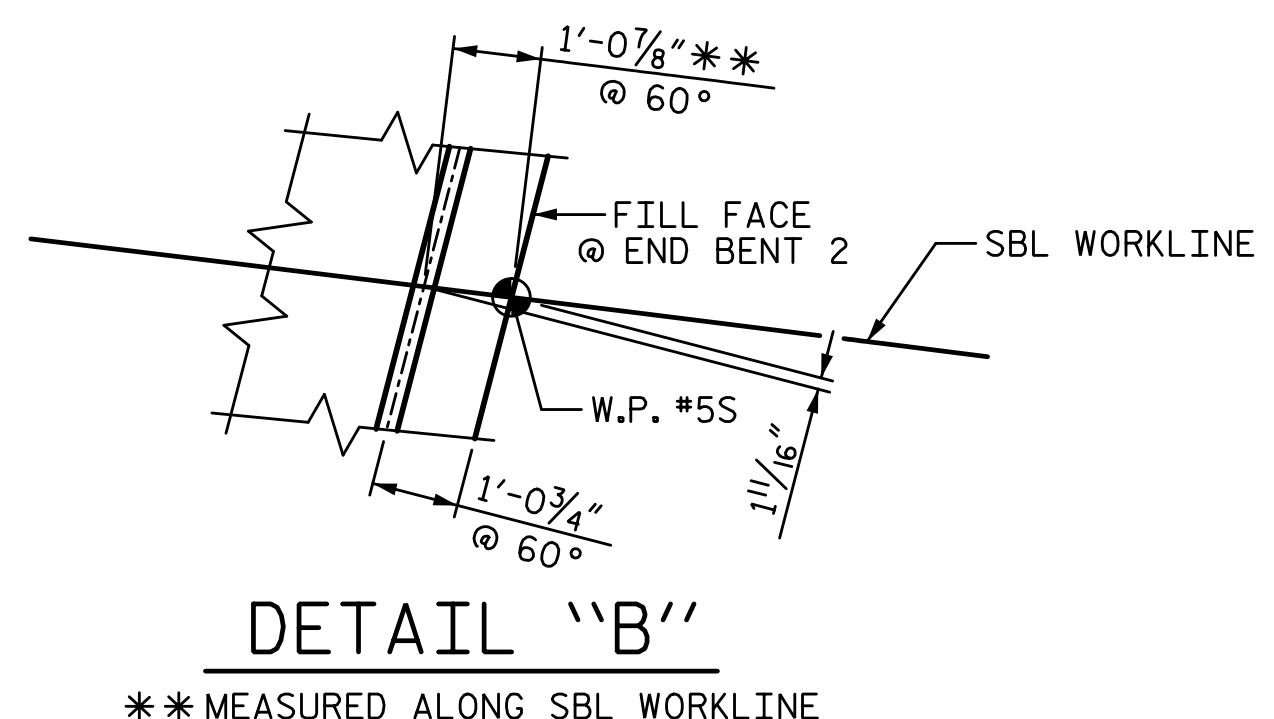
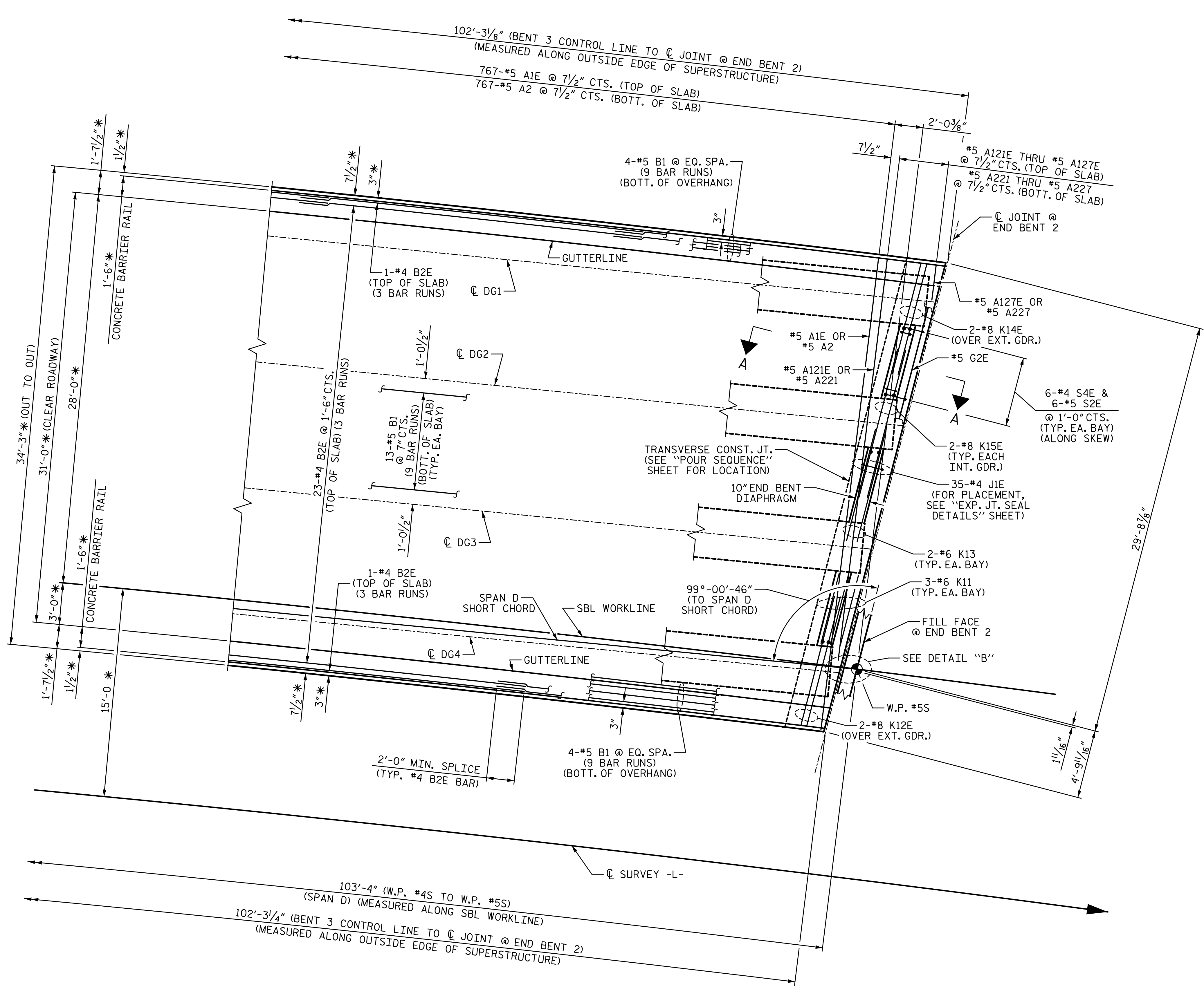

**PART PLAN - SPAN D**  
 \* RADIAL DIMENSION  
 FOR NOTES, SEE SHEET 1 OF 5

PROJECT NO. U-3109A  
ALAMANCE COUNTY  
 STATION: 146+61.35 -L-

SHEET 5 OF 5

STATE OF NORTH CAROLINA DEPARTMENT OF TRANSPORTATION RALEIGH SUPERSTRUCTURE					
PLAN OF SPANS (SBL)					
SHEET NO. S02-15					
TOTAL SHEETS S02-51					
REVISIONS					
NO.	BY:	DATE:	NO.	BY:	DATE:
1			3		
2			4		

PLANS PREPARED BY:  
**SIMPSON ENGINEERS & ASSOCIATES**  
 5640 Dillard Drive  
 Suite 200  
 Cary, NC 27518  
 (919) 852-0468  
 (919) 852-0598 (Fax)  
 www.simpsonengr.com  
 LICENSURE NO. C-2521



DRAWN BY: T. BANKOVICH	DATE: 9-15
CHECKED BY: J.A. BATTS	DATE: 9-15
DESIGN ENGINEER OF RECORD: J.A. BATTS	DATE: 9-15

STR. #2