

**EDI MODEL 2018ECL-NC CONFLICT MONITOR  
PROGRAMMING DETAIL**

(remove jumpers and set switches as shown)

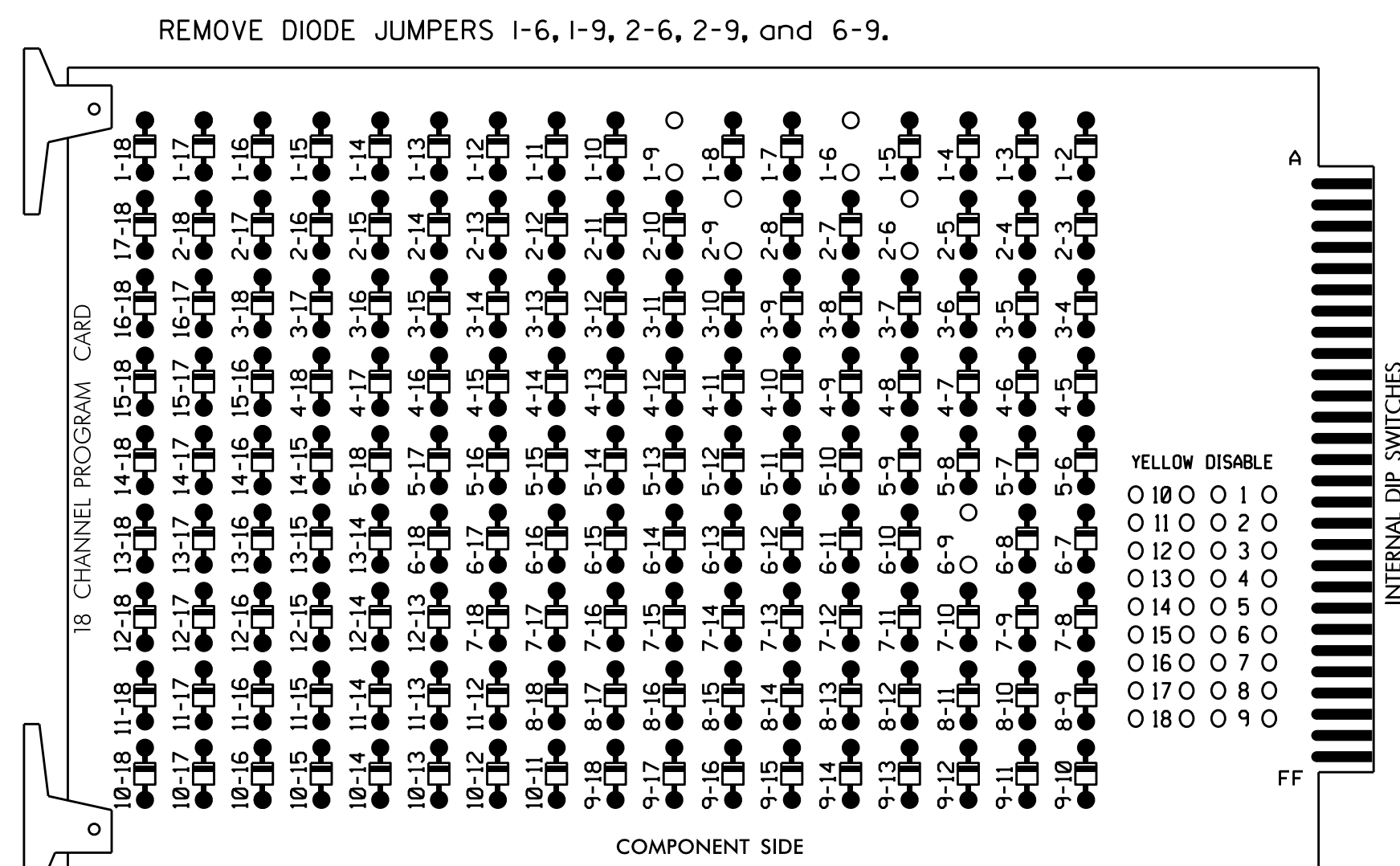

**NOTES:**

1. Card is provided with all diode jumpers in place. Removal of any jumper allows its channels to run concurrently.
2. Ensure jumpers SEL2-SEL5 and SEL9 are present on the monitor board.
3. Ensure that Red Enable is active at all times during normal operation.
4. Connect serial cable from conflict monitor to comm. port 1 of 2070 controller. Ensure conflict monitor communicates with 2070.

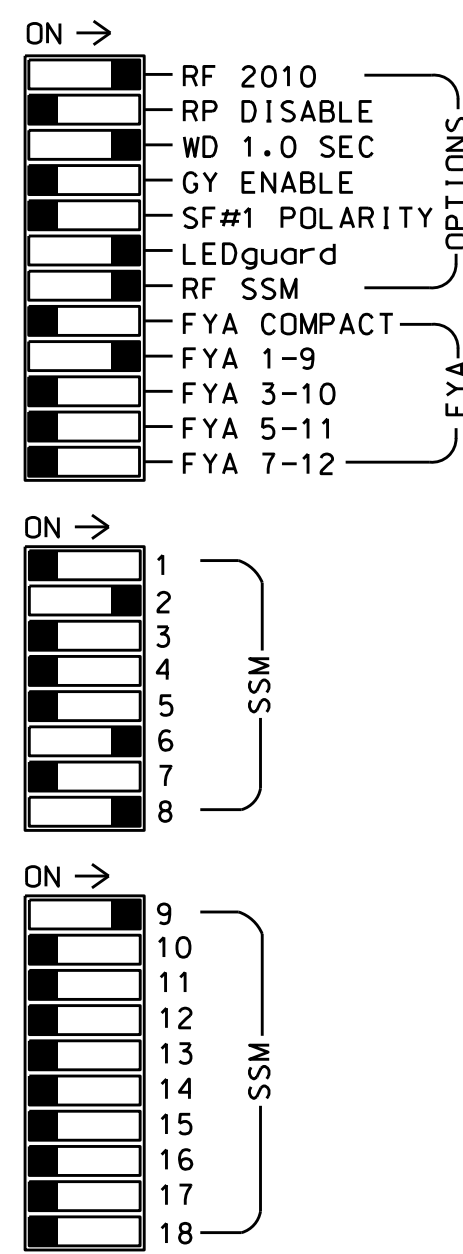
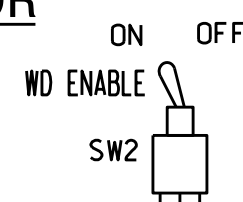

■ = DENOTES POSITION OF SWITCH

**NOTES**

1. To prevent "flash-conflict" problems, insert red flash program blocks for all unused vehicle load switches in the output file. The installer shall verify that signal heads flash in accordance with the Signal Plans.
2. Enable Simultaneous Gap-Out for all phases.
3. Program phases 2 and 6 for Variable Initial and Gap Reduction.
4. Program phases 2 and 6 for Start Up In Green.
5. Program phases 2 and 6 for Yellow Flash, and overlap 1 as Wag Overlaps.

**EQUIPMENT INFORMATION**

CONTROLLER.....2070  
 CABINET.....332 W/ AUX  
 SOFTWARE.....ECONOLITE OASIS  
 CABINET MOUNT.....BASE  
 OUTPUT FILE POSITIONS...18 WITH AUX. OUTPUT FILE  
 LOAD SWITCHES USED.....S1,S2,S8,S11,AUX S1  
 PHASES USED.....1,2,6,8  
 OVERLAP "A".....1+2  
 OVERLAP "B".....NOT USED  
 OVERLAP "C".....NOT USED  
 OVERLAP "D".....NOT USED

**SIGNAL HEAD HOOK-UP CHART**

LOAD SWITCH NO.	S1	S2	S3	S4	S5	S6	S7	S8	S9	S10	S11	S12	AUX S1	AUX S2	AUX S3	AUX S4	AUX S5	AUX S6
CMU CHANNEL NO.	1	2	13	3	4	14	5	6	15	7	8	16	9	10	17	11	12	18
PHASE	1	2	2 PED	3	4	4 PED	5	6	6 PED	7	8	8 PED	OLA	OLB	SPARE	OLC	OLD	SPARE
SIGNAL HEAD NO.	11	21,22	NU	NU	NU	NU	NU	61,62	NU	NU	81,82	NU	11	NU	NU	NU	NU	NU
RED		128						134			107							
YELLOW	*	129						135			108							
GREEN		130						136			109							
RED ARROW													A121					
YELLOW ARROW													A122					
FLASHING YELLOW ARROW													A123					
GREEN ARROW	127																	

NU = Not Used

\* Denotes install load resistor. See load resistor installation detail this sheet.

★ See pictorial of head wiring in detail this sheet.

**INPUT FILE POSITION LAYOUT**

(front view)

FILE "I"	1	2	3	4	5	6	7	8	9	10	11	12	13	14
U	∅ 1	∅ 2	-OR-	-OR-	-OR-	-OR-	-OR-	-OR-	-OR-	-OR-	-OR-	-OR-	-OR-	FS
L	1A	2A												DC ISOLATOR
U	NOT USED	NOT USED	∅ 6	∅ 8	∅ 8	∅ 8	∅ 8	∅ 8	∅ 8	∅ 8	∅ 8	∅ 8	∅ 8	DC ISOLATOR
L														

EX.: 1A, 2A, ETC. = LOOP NO.'S

FS = FLASH SENSE  
 ST = STOP TIME

⊗ Wired Input - Do not populate slot with detector card

**INPUT FILE CONNECTION & PROGRAMMING CHART**

LOOP NO.	LOOP TERMINAL	INPUT FILE POS.	PIN NO.	INPUT ASSIGNMENT NO.	DETECTOR NO.	NEMA PHASE	CALL	EXTEND	FULL TIME DELAY	STRETCH TIME	DELAY TIME
1A <sup>1</sup>	TB2-1,2	I1U	56	18	1	1	Y	Y			15
	-	J4U	48	10	26	6	Y	Y	Y		3
2A	TB2-5,6	I2U	39	1	2	2	Y	Y			
6A	TB3-5,6	J2U	40	2	6	6	Y	Y			
8A	TB5-9,10	J6U	42	4	8	8	Y	Y			3

<sup>1</sup>Add jumper from I1-W to J4-W, on rear of input file.

**INPUT FILE POSITION LEGEND: J2L**

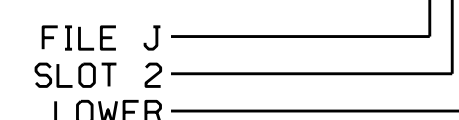

**FYA SIGNAL WIRING DETAIL**

(wire signal head as shown)

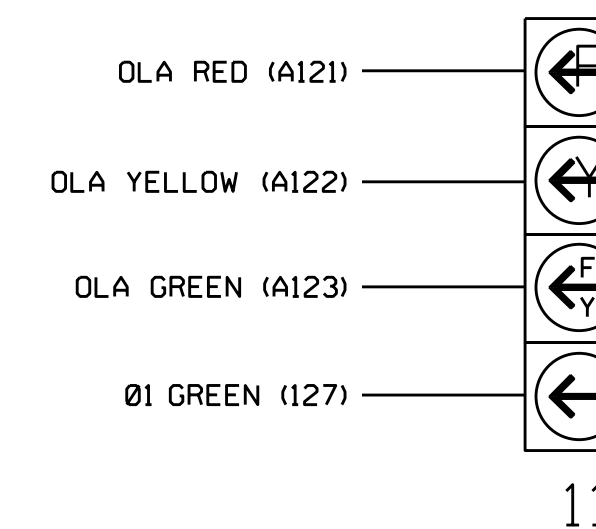

**NOTE**

The sequence display for signal head 11 requires special logic programming. See sheet 2 for programming instructions.

**LOAD RESISTOR INSTALLATION DETAIL**

(install resistor as shown below)

VALUE (ohms)	WATTAGE
1.5K - 1.9K	25W (min)
2.0K - 3.0K	10W (min)

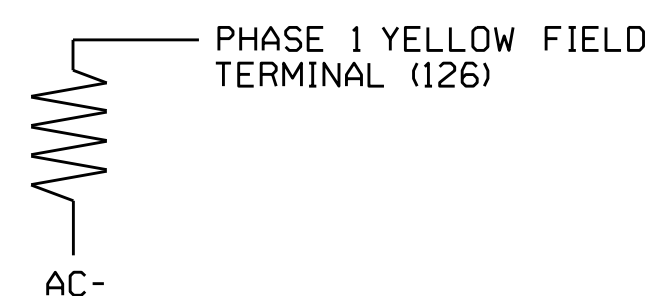

IMPORTANT! Remove resistor from phase 1 red terminal, if present.

Electrical Detail - Temp 2 (TMP Phase IIB) - Sheet 1 of 2

Electrical and Programming Details for: SR 1962 (S. Third Street) at SR 1980 (Holmes Road)

Prepared in the Offices of: **TRANSPO-MOBILITY AND SAFETY SOLUTIONS** (Professional Engineering Firm, License No. 28000)

750 N. Greenfield Pkwy, Garner, NC 27529

Division 7 Alamance County Mebane

PLAN DATE: January 2017 REVIEWED BY: BAS

PREPARED BY: S. Armstrong REVIEWED BY:

REVISIONS: \_\_\_\_\_ INIT. DATE

DocuSigned by: **Keith M. Mins** 1/26/2017

SEAL: 036880 ENGINEER KEITH M. MINS

SIG. INVENTORY NO. 07-2132T2