

**This electronic collection of documents is provided
for the convenience of the user
and is Not a Certified Document –**

**The documents contained herein were originally issued
and sealed by the individuals whose names and license
numbers appear on each page, on the dates appearing
with their signature on that page.**

**This file or an individual page
shall not be considered a certified document.**

★ PROPOSED SIGNAL

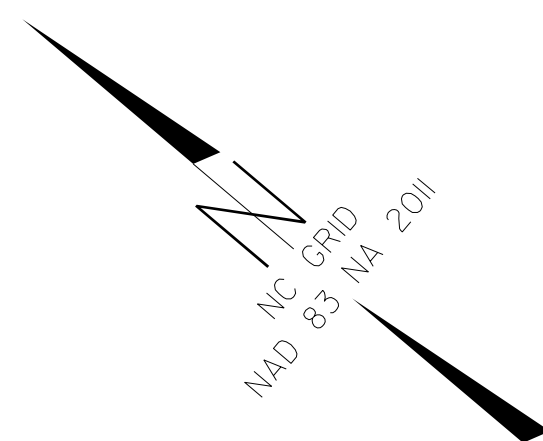

PROJECT REFERENCE NO. W-5520	SHEET NO. PMP-2
APPROVED: <i>Lisa M. Moon</i>	
DATE: 9/1/2016	
SEAL	
<p>DOCUMENT NOT CONSIDERED FINAL UNLESS ALL SIGNATURES COMPLETED</p>	

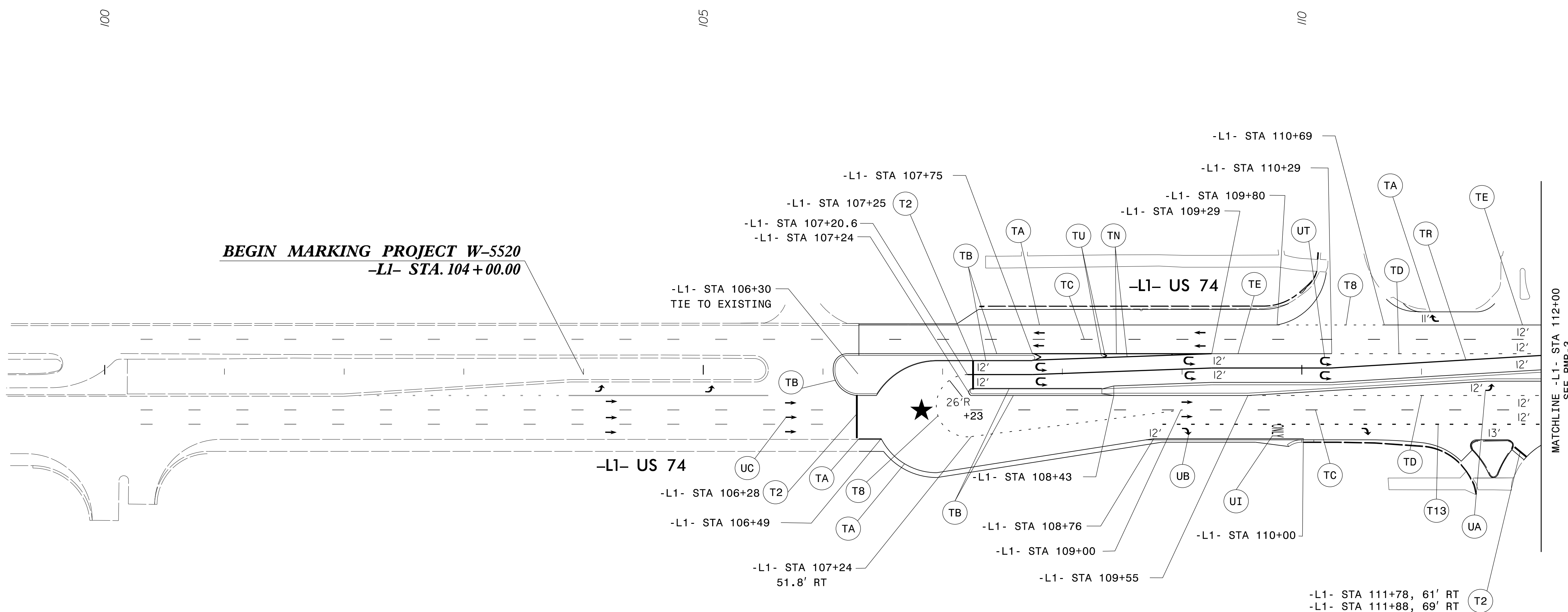

**BEGIN MARKING PROJECT W-5520
-L1- STA. 104+00.00**

**THERMOPLASTIC PAVEMENT
MARKING SCHEDULE**

SYMBOL	DESCRIPTION
T2	WHITE STOP BAR (24", 120 MIL)
T8	2FT.-6FT./SP WHITE MINISKIP (4", 120 MIL)
T9	2FT.-6FT./SP YELLOW MINISKIP (4", 120 MIL)
T13	3FT.-9FT./SP WHITE MINISKIP (8", 120 MIL)
TA	WHITE EDGELINE (4", 90 MIL)
TB	YELLOW EDGELINE (4", 90 MIL)
TC	10FT. WHITE SKIP LINE (4" 120 MIL)
TD	3FT.-9FT./SP WHITE MINISKIP (4", 120 MIL)
TE	WHITE SOLID LANE LINE (4", 120 MIL)
TN	WHITE GORELINE (8", 90 MIL)
TR	WHITE SOLID LANE LINE (8", 120 MIL)
TU	WHITE DIAGONAL (12", 90 MIL)
UA	LEFT TURN ARROW (90 MIL)
UB	RIGHT TURN ARROW (90 MIL)
UC	STRAIGHT ARROW (90 MIL)
UI	ALPHANUMERIC CHAR (120 MIL)
UT	U-TURN ARROW (90 MIL)
MB	PERMANENT RAISED MARKER, CRYSTAL & RED

01-SEP-2016 08:10
 N:\Projects\W5520\Drawings\CAADD\Pvt\Marking Layout\Plans\W5520_Sgn_PMP_02.dgn
 AT: CARPENTIER, W.

PLANS PREPARED BY:

DRMP
ENGINEERS • PLANNERS • SCIENTISTS

DRMP, INC.
5650 FAIRVIEW ROAD, SUITE 330
CHARLOTTE, NC 28210
NC LICENSE NO. C-2213 • (704) 332-2289

PAVEMENT MARKING DETAIL
-L1- STA 100+00 TO -L1- STA 112+00

★ PROPOSED SIGNAL

PROJECT REFERENCE NO. W-5520 SHEET NO. PMP-3

APPROVED: Lisa M. Moon

DATE: 1/5/2017

SEAL

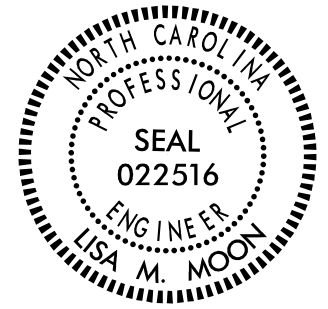

DOCUMENT NOT CONSIDERED FINAL UNLESS ALL SIGNATURES COMPLETED

CURB RAMP STATION*	CURB RAMP TYPE
1 -L1- STA 115+52, 78' LT	STANDARD
2 -L1- STA 115+11, 88' LT	STANDARD
3 -L1- STA 115+65, 82' RT	TYPE 2A
4 -L1- STA 116+58, 82' RT	TYPE 1A
5 -L1- STA 116+74, 68' LT	STANDARD
6 -L1- STA 116+62, 79' LT	STANDARD

*CENTERLINE OF RAMP AT FACE OF CURB

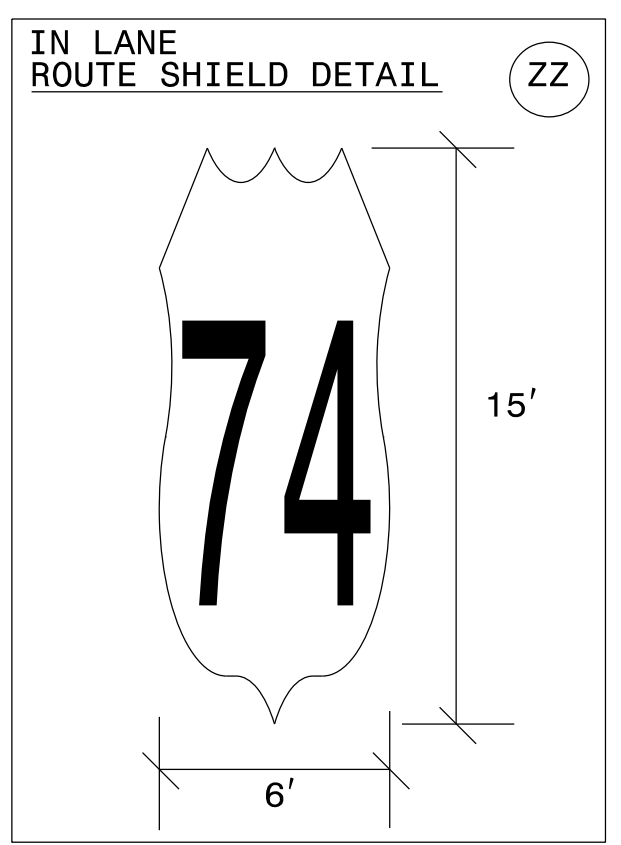
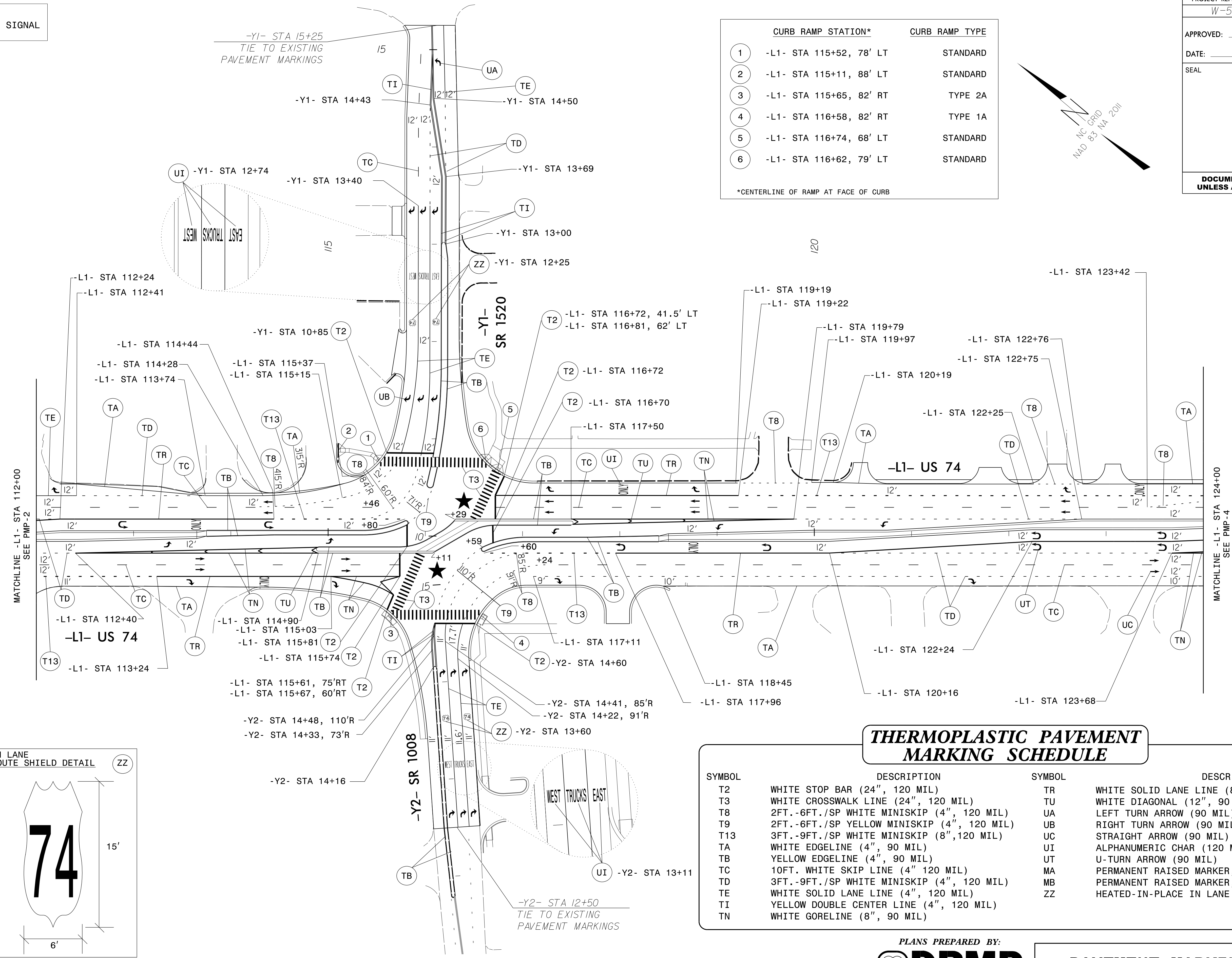
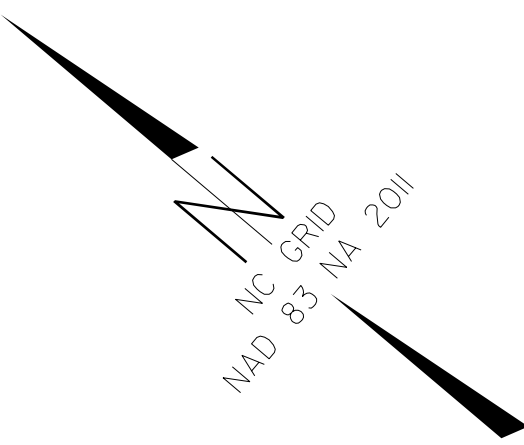

THERMOPLASTIC PAVEMENT MARKING SCHEDULE

SYMBOL	DESCRIPTION	SYMBOL	DESCRIPTION
T2	WHITE STOP BAR (24", 120 MIL)	TR	WHITE SOLID LANE LINE (8", 120 MIL)
T3	WHITE CROSSWALK LINE (24", 120 MIL)	TU	WHITE DIAGONAL (12", 90 MIL)
T8	2FT.-6FT./SP WHITE MINISKIP (4", 120 MIL)	UA	LEFT TURN ARROW (90 MIL)
T9	2FT.-6FT./SP YELLOW MINISKIP (4", 120 MIL)	UB	RIGHT TURN ARROW (90 MIL)
T13	3FT.-9FT./SP WHITE MINISKIP (8", 120 MIL)	UC	STRAIGHT ARROW (90 MIL)
TA	WHITE EDGELINE (4", 90 MIL)	UI	ALPHANUMERIC CHAR (120 MIL)
TB	YELLOW EDGELINE (4", 90 MIL)	UT	U-TURN ARROW (90 MIL)
TC	10FT. WHITE SKIP LINE (4" 120 MIL)	MA	PERMANENT RAISED MARKER, YELLOW & YELLOW
TD	3FT.-9FT./SP WHITE MINISKIP (4", 120 MIL)	MB	PERMANENT RAISED MARKER, CRYSTAL & RED
TE	WHITE SOLID LANE LINE (4", 120 MIL)	ZZ	HEATED-IN-PLACE IN LANE ROUTE SHIELD
TI	YELLOW DOUBLE CENTER LINE (4", 120 MIL)		
TN	WHITE GORELINE (8", 90 MIL)		

PLANS PREPARED BY:
DRMP
ENGINEERS · PLANNERS · SCIENTISTS

PAVEMENT MARKING DETAIL
-L1- STA 112+00 TO -L1- STA 124+00

DRMP, INC.
5650 FAIRVIEW ROAD, SUITE 330
CHARLOTTE, NC 28210
NC LICENSE NO. C-2213 (704) 332-2289

DE: JAN-2017 12:18
 NS: PMP-3 US 74 SR 1520 Marking Layout Plans W5520_Sgn_PMP_03.dgn
 AT: SCARLETT AWLON-W7
 Location

★ PROPOSED SIGNAL

PROJECT REFERENCE NO. W-5520	SHEET NO. PMP-4
APPROVED: <i>Lisa M. Moon</i>	
DATE: 9/1/2016	
SEAL	
	
DOCUMENT NOT CONSIDERED FINAL UNLESS ALL SIGNATURES COMPLETED	

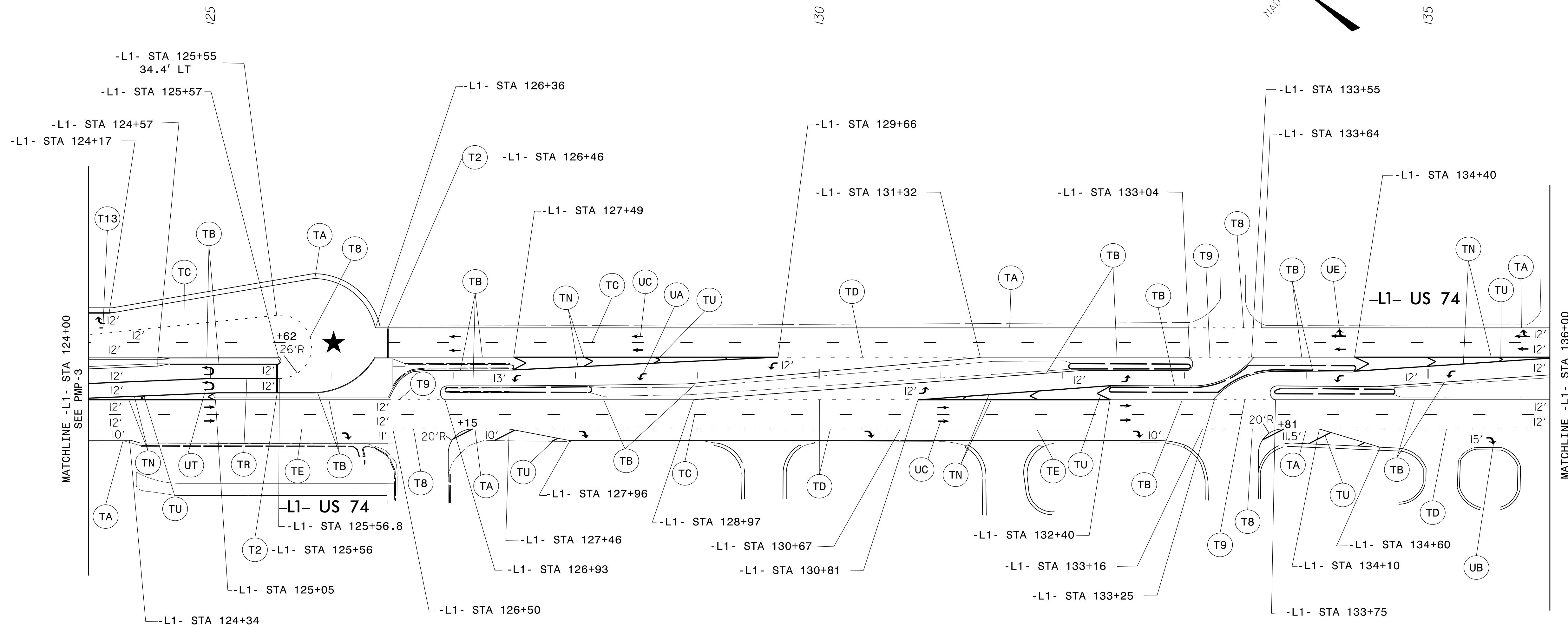

THERMOPLASTIC PAVEMENT MARKING SCHEDULE

SYMBOL	DESCRIPTION
T2	WHITE STOP BAR (24", 120 MIL)
T8	2FT.-6FT./SP WHITE MINISKIP (4", 120 MIL)
T9	2FT.-6FT./SP YELLOW MINISKIP (4", 120 MIL)
T13	3FT.-9FT./SP WHITE MINISKIP (8", 120 MIL)
TA	WHITE EDGE LINE (4", 90 MIL)
TB	YELLOW EDGE LINE (4", 90 MIL)
TC	10FT. WHITE SKIP LINE (4" 120 MIL)
TD	3FT.-9FT./SP WHITE MINISKIP (4", 120 MIL)
TE	WHITE SOLID LANE LINE (4", 120 MIL)
TN	WHITE GORE LINE (8", 90 MIL)
TR	WHITE SOLID LANE LINE (8", 120 MIL)
TU	WHITE DIAGONAL (12", 90 MIL)
UA	LEFT TURN ARROW (90 MIL)
UB	RIGHT TURN ARROW (90 MIL)
UC	STRAIGHT ARROW (90 MIL)
UE	COMBO RIGHT/STRAIGHT ARROW (90 MIL)
UT	U-TURN ARROW (90 MIL)
MB	PERMANENT RAISED MARKER, CRYSTAL & RED

PLANS PREPARED BY:

 DRMP, INC.
 ENGINEERS • PLANNERS • SCIENTISTS

5650 FAIRVIEW ROAD, SUITE 330
 CHARLOTTE, NC 28210
 NC LICENSE NO. C-2213 • (704) 332-2289

PAVEMENT MARKING DETAIL
 -L1- STA 124+00 TO -L1- STA 136+00

01-SEP-2016 08:10
 N:\Projects\W5520\Drawings\CADD\Plan\Marking Layout\Plans\W5520_Sgn_PMP_04.dgn
 AT: CLARENCE W. WATSON

★ PROPOSED SIGNAL

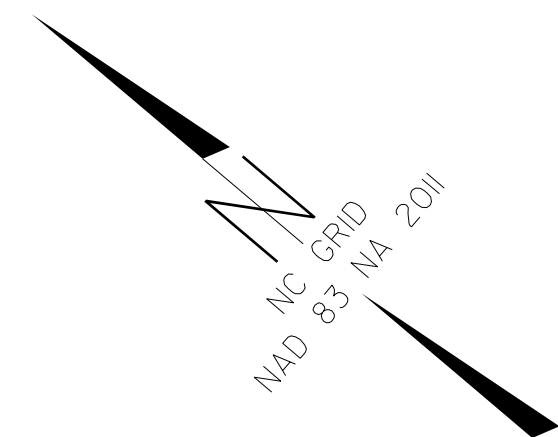

PROJECT REFERENCE NO. *W-5520* SHEET NO. *PMP-5*

APPROVED: *Lisa M. Moon*

DATE: 9/1/2016

SEAL



DOCUMENT NOT CONSIDERED FINAL
UNLESS ALL SIGNATURES COMPLETED

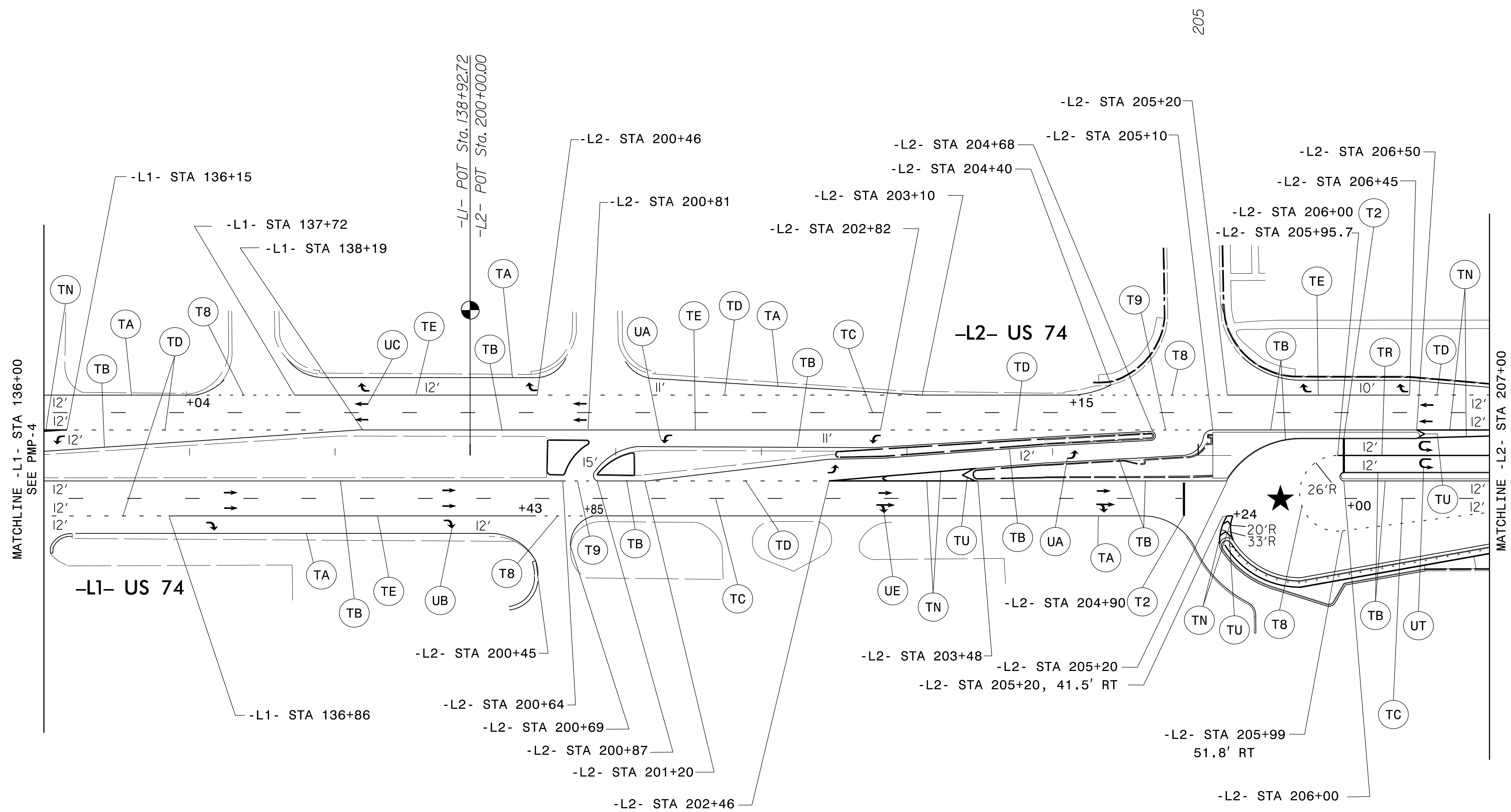

THERMOPLASTIC PAVEMENT MARKING SCHEDULE

SYMBOL	DESCRIPTION
T2	WHITE STOP BAR (24", 120 MIL)
T8	2FT.-6FT./SP WHITE MINISKIP (4", 120 MIL)
T9	2FT.-6FT./SP YELLOW MINISKIP (4", 120 MIL)
TA	WHITE EDGELINE (4", 90 MIL)
TB	YELLOW EDGELINE (4", 90 MIL)
TC	10FT. WHITE SKIP LINE (4" 120 MIL)
TD	3FT.-9FT./SP WHITE MINISKIP (4", 120 MIL)
TE	WHITE SOLID LANE LINE (4", 120 MIL)
TN	WHITE GORELINE (8", 90 MIL)
TR	WHITE SOLID LANE LINE (8", 120 MIL)
TU	WHITE DIAGONAL (12", 90 MIL)
UA	LEFT TURN ARROW (90 MIL)
UB	RIGHT TURN ARROW (90 MIL)
UC	STRAIGHT ARROW (90 MIL)
UE	COMBO RIGHT/STRAIGHT ARROW (90 MIL)
UT	U-TURN ARROW (90 MIL)
MB	PERMANENT RAISED MARKER, CRYSTAL & RED

01-SEP-2016 08:10
 N:\Projects\W5520\Drawings\CADD\Plan\Marking Layout\Plans\W5520_Sgn_PMP_05.dgn
 AT: CLARENCE@DRMP.COM
 CLARENCE

PLANS PREPARED BY:

DRMP
ENGINEERS • PLANNERS • SCIENTISTS

DRMP, INC.
5650 FAIRVIEW ROAD, SUITE 330
CHARLOTTE, NC 28210
NC LICENSE NO. C-2213 (704) 332-2289

PAVEMENT MARKING PLANS
-L1- STA 136+00 TO -L2- STA 207+00

★ PROPOSED SIGNAL

NC GRID
MAD 83 NA 2011

PROJECT REFERENCE NO. W-5520	SHEET NO. PMP-6
APPROVED: <i>Lisa M. Moon</i>	
DATE: 1/5/2017	
SEAL	
DOCUMENT NOT CONSIDERED FINAL UNLESS ALL SIGNATURES COMPLETED	

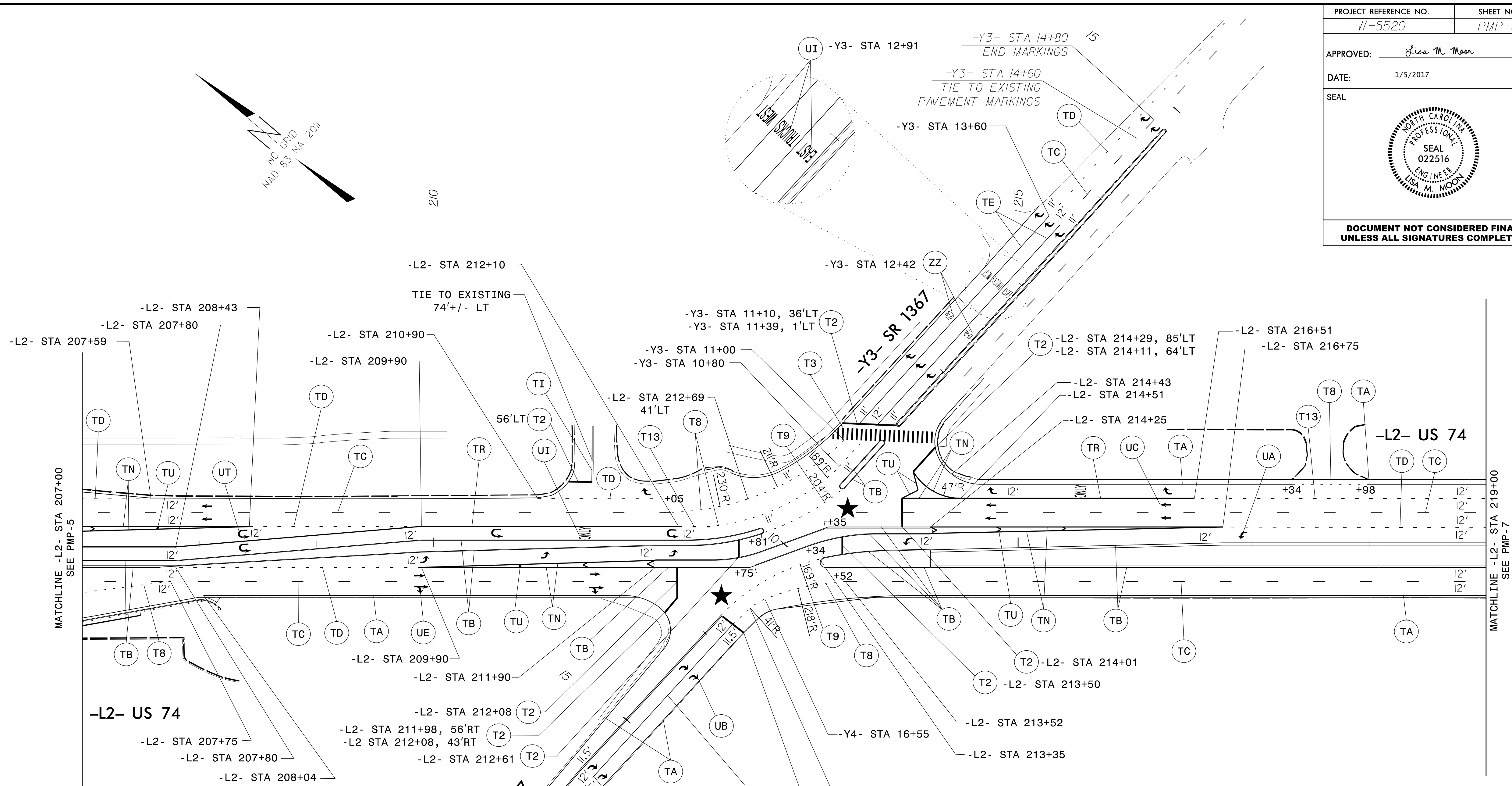

THERMOPLASTIC PAVEMENT MARKING SCHEDULE

SYMBOL	DESCRIPTION
T2	WHITE STOP BAR (24", 120 MIL)
T3	WHITE CROSSWALK LINE (24", 120 MIL)
T8	2FT.-6FT./SP WHITE MINISKIP (4", 120 MIL)
T9	2FT.-6FT./SP YELLOW MINISKIP (4", 120 MIL)
T13	3FT.-9FT./SP WHITE MINISKIP (8", 120 MIL)
TA	WHITE EDGELINE (4", 90 MIL)
TB	YELLOW EDGELINE (4", 90 MIL)
TC	10FT. WHITE SKIP LINE (4" 120 MIL)
TD	3FT.-9FT./SP WHITE MINISKIP (4", 120 MIL)
TE	WHITE SOLID LANE LINE (4", 120 MIL)
TI	YELLOW DOUBLE CENTER LINE (4", 120 MIL)
TN	WHITE GORELINE (8", 90 MIL)
TR	WHITE SOLID LANE LINE (8", 120 MIL)
TU	WHITE DIAGONAL (12", 90 MIL)
UA	LEFT TURN ARROW (90 MIL)
UB	RIGHT TURN ARROW (90 MIL)
UC	STRAIGHT ARROW (90 MIL)
UE	COMBO RIGHT/STRAIGHT ARROW (90 MIL)
UI	ALPHANUMERIC CHAR (120 MIL)
UT	U-TURN ARROW (90 MIL)
MA	PERMANENT RAISED MARKER, YELLOW & YELLOW
MB	PERMANENT RAISED MARKER, CRYSTAL & RED
ZZ	HEATED-IN-PLACE IN LANE ROUTE SHIELD

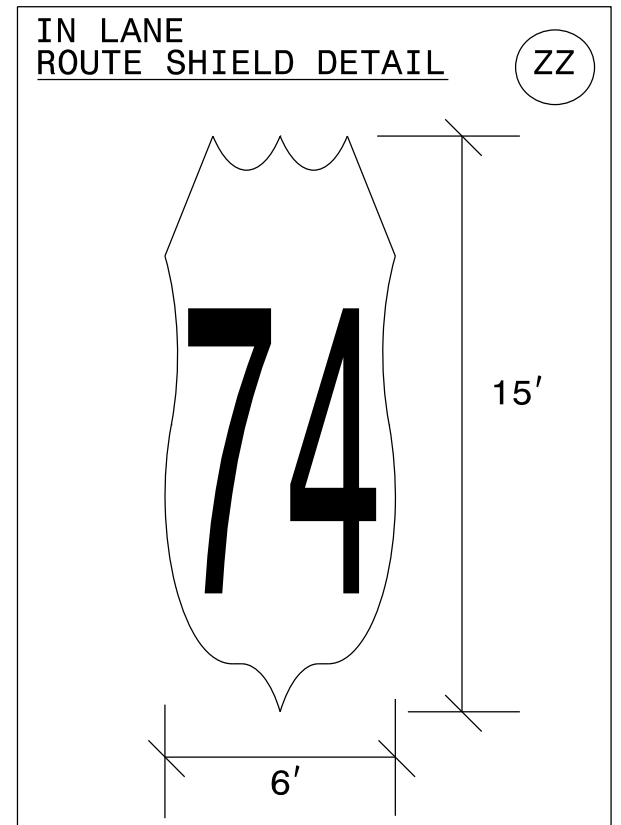

05-14N-2017 12:18
 NC:\pmp\w5520\CADD\pmp\Marking_Layout_Plans\W5520_Sgn_PMP_06.dgn
 1/5/17 1:14 PM
 AT: SARA PELAWTON-W7
 PLANTON

PLANS PREPARED BY:

DRMP
ENGINEERS · PLANNERS · SCIENTISTS

DRMP, INC.
5950 FAIRVIEW ROAD, SUITE 330
CHARLOTTE, NC 28210
NC LICENSE NO. C-2213 • (704) 332-2289

PAVEMENT MARKING PLANS
-L2- STA 207+00 TO -L2- STA 219+00

★ PROPOSED SIGNAL

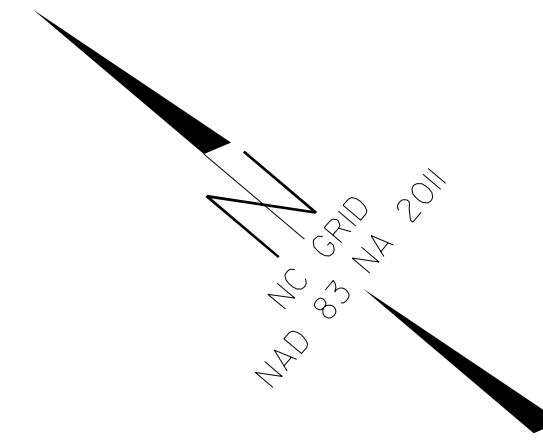

PROJECT REFERENCE NO. W-5520	SHEET NO. PMP-7
APPROVED: <i>Lisa M. Moon</i>	
DATE: 9/1/2016	
SEAL	
DOCUMENT NOT CONSIDERED FINAL UNLESS ALL SIGNATURES COMPLETED	

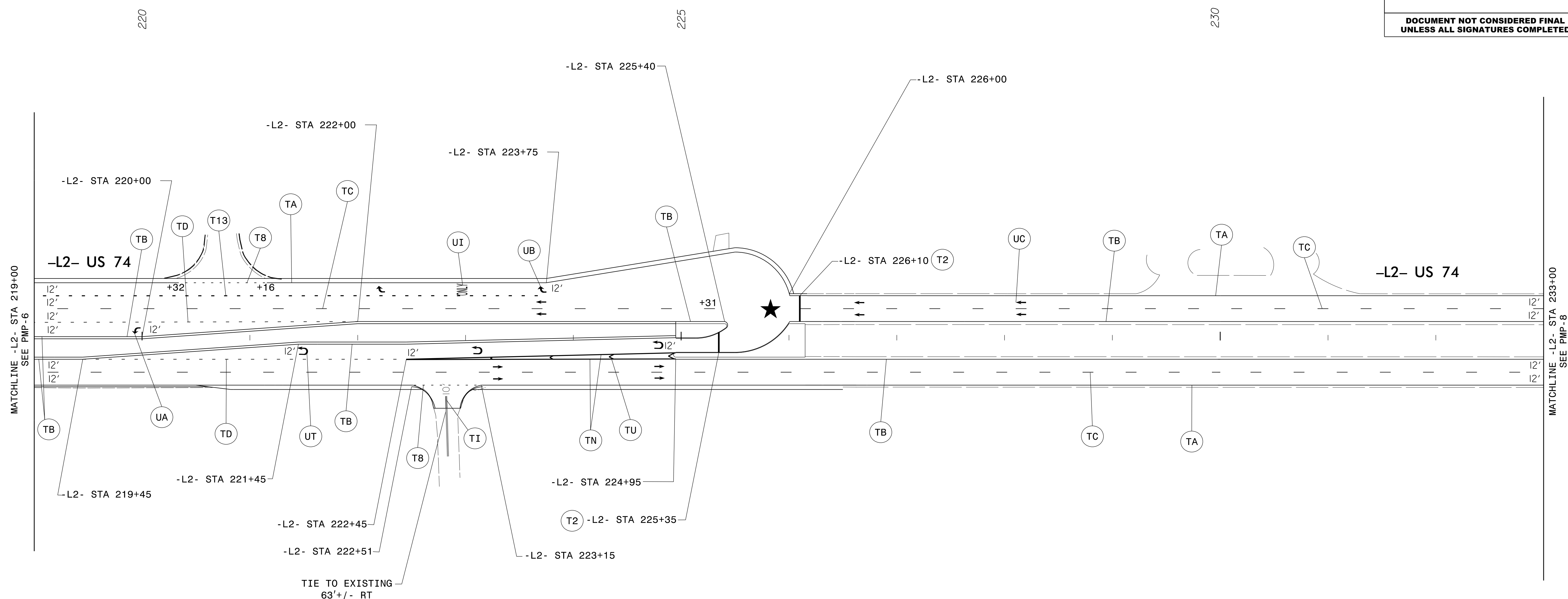

THERMOPLASTIC PAVEMENT MARKING SCHEDULE

SYMBOL	DESCRIPTION
T2	WHITE STOP BAR (24", 120 MIL)
T8	2FT.-6FT./SP WHITE MINISKIP (4", 120 MIL)
T9	2FT.-6FT./SP YELLOW MINISKIP (4", 120 MIL)
T13	3FT.-9FT./SP WHITE MINISKIP (8", 120 MIL)
TA	WHITE EDGELINE (4", 90 MIL)
TB	YELLOW EDGELINE (4", 90 MIL)
TC	10FT. WHITE SKIP LINE (4" 120 MIL)
TD	3FT.-9FT./SP WHITE MINISKIP (4", 120 MIL)
TN	WHITE GORELINE (8", 90 MIL)
TU	WHITE DIAGONAL (12", 90 MIL)
UA	LEFT TURN ARROW (90 MIL)
UB	RIGHT TURN ARROW (90 MIL)
UC	STRAIGHT ARROW (90 MIL)
UI	ALPHANUMERIC CHAR (120 MIL)
UT	U-TURN ARROW (90 MIL)
MB	PERMANENT RAISED MARKER, CRYSTAL & RED

01-SEP-2016 08:10
 N:\Projects\W5520\Drawings\CADD\Plan\Marking Layout\Plans\W5520_Sgn_PMP_07.dgn
 AT: CARPENTIER, W.

PLANS PREPARED BY:

DRMP
ENGINEERS • PLANNERS • SCIENTISTS

DRMP, INC.
5650 FAIRVIEW ROAD, SUITE 330
CHARLOTTE, NC 28210
NC LICENSE NO. C-2213 • (704) 332-2289

PAVEMENT MARKING PLANS
-L2- STA 219+00 TO -L2- STA 233+00

★ PROPOSED SIGNAL

PROJECT REFERENCE NO. W-5520	SHEET NO. PMP-8
APPROVED: <i>Lisa M. Moon</i>	
DATE: 9/1/2016	
SEAL	
DOCUMENT NOT CONSIDERED FINAL UNLESS ALL SIGNATURES COMPLETED	

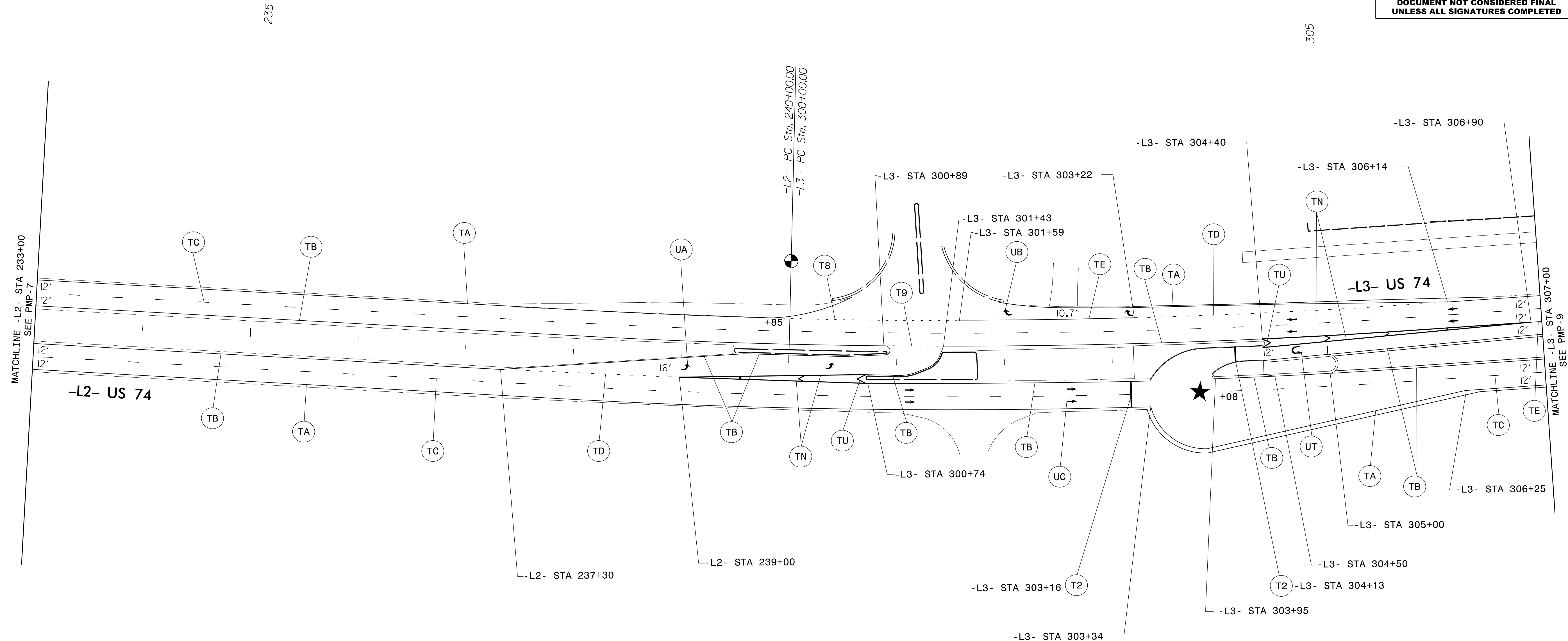
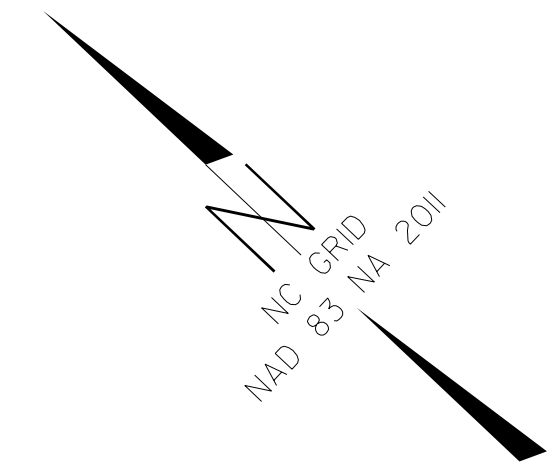

THERMOPLASTIC PAVEMENT MARKING SCHEDULE

SYMBOL	DESCRIPTION
T2	WHITE STOP BAR (24", 120 MIL)
T8	2FT.-6FT./SP WHITE MINISKIP (4", 120 MIL)
T9	2FT.-6FT./SP YELLOW MINISKIP (4", 120 MIL)
TA	WHITE EDGELINE (4", 90 MIL)
TB	YELLOW EDGELINE (4", 90 MIL)
TC	10FT. WHITE SKIP LINE (4" 120 MIL)
TD	3FT.-9FT./SP WHITE MINISKIP (4", 120 MIL)
TE	WHITE SOLID LANE LINE (4", 120 MIL)
TN	WHITE GORELINE (8", 90 MIL)
TU	WHITE DIAGONAL (12", 90 MIL)
UA	LEFT TURN ARROW (90 MIL)
UB	RIGHT TURN ARROW (90 MIL)
UC	STRAIGHT ARROW (90 MIL)
UT	U-TURN ARROW (90 MIL)
MB	PERMANENT RAISED MARKER, CRYSTAL & RED

01-SEP-2016 08:10
 N:\Projects\W5520\Drawings\CADD\Plan\Marking_Layout\Plans\W5520_Sgn_PMP_08.dgn
 AT: CLARENCE

PLANS PREPARED BY:

DRMP
ENGINEERS • PLANNERS • SCIENTISTS

DRMP, INC.
5650 FAIRVIEW ROAD, SUITE 330
CHARLOTTE, NC 28210
NC LICENSE NO. C-2213 • (704) 332-2289

PAVEMENT MARKING PLANS
-L2- STA 233+00 TO -L3- STA 307+00

★ PROPOSED SIGNAL

PROJECT REFERENCE NO. W-5520	SHEET NO. PMP-9
APPROVED: <i>Lisa M. Moon</i>	
DATE: 1/5/2017	
SEAL	
	
DOCUMENT NOT CONSIDERED FINAL UNLESS ALL SIGNATURES COMPLETED	

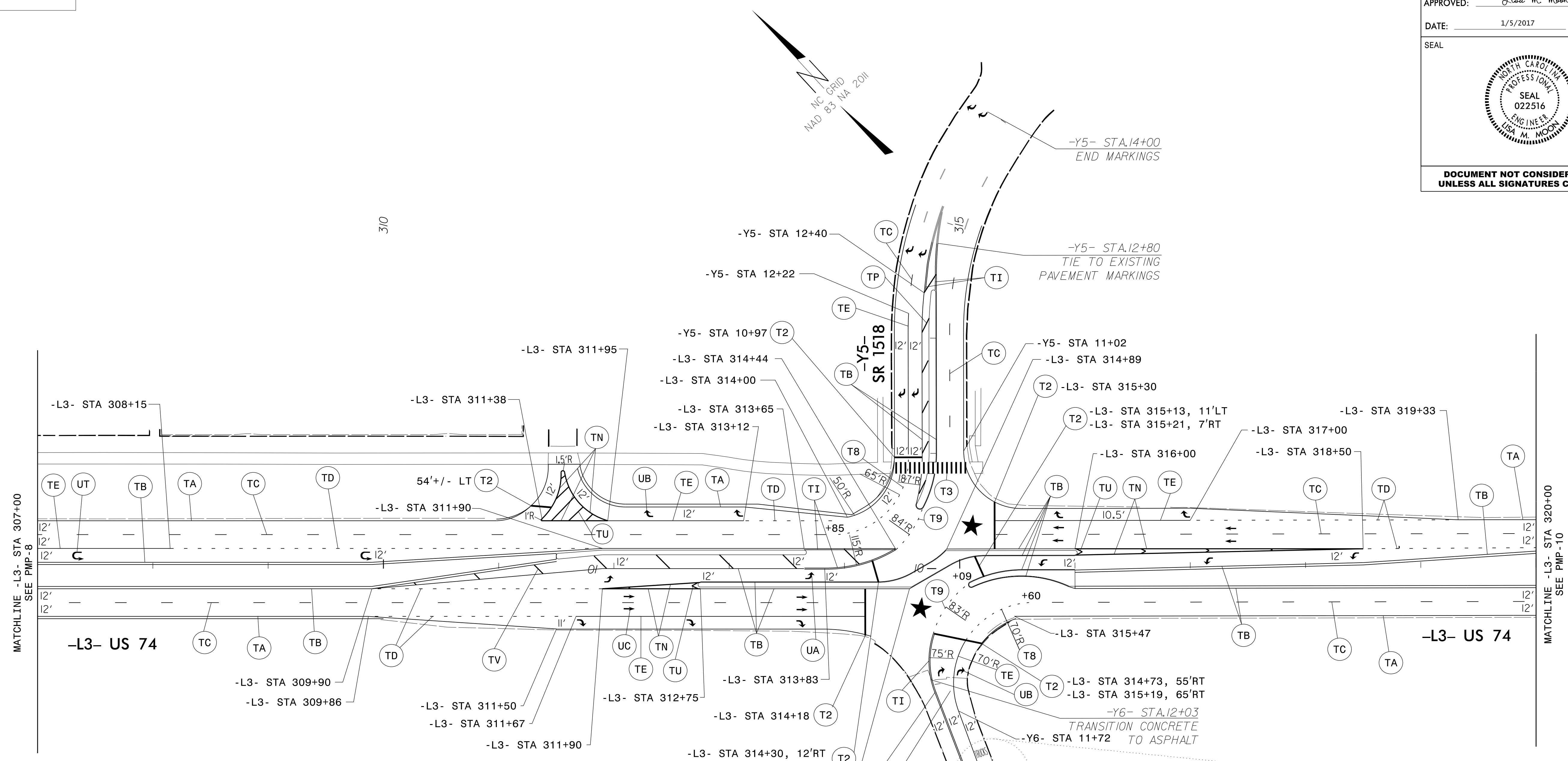

THERMOPLASTIC PAVEMENT MARKING SCHEDULE

SYMBOL	DESCRIPTION
T2	WHITE STOP BAR (24", 120 MIL)
T3	WHITE CROSSWALK LINE (24", 120 MIL)
T8	2FT.-6FT./SP WHITE MINISKIP (4", 120 MIL)
T9	2FT.-6FT./SP YELLOW MINISKIP (4", 120 MIL)
TA	WHITE EDGELINE (4", 90 MIL)
TB	YELLOW EDGELINE (4", 90 MIL)
TC	10FT. WHITE SKIP LINE (4" 120 MIL)
TD	3FT.-9FT./SP WHITE MINISKIP (4", 120 MIL)
TE	WHITE SOLID LANE LINE (4", 120 MIL)
TI	YELLOW DOUBLE CENTER LINE (4", 120 MIL)
TN	WHITE GORELINE (8", 90 MIL)
TP	YELLOW DIAGONAL (8", 90 MIL)
TU	WHITE DIAGONAL (12", 90 MIL)
TV	YELLOW DIAGONAL (12", 90 MIL)
UA	LEFT TURN ARROW (90 MIL)
UB	RIGHT TURN ARROW (90 MIL)
UC	STRAIGHT ARROW (90 MIL)
UI	ALPHANUMERIC CHAR (120 MIL)
UT	U-TURN ARROW (90 MIL)
MA	PERMANENT RAISED MARKER, YELLOW & YELLOW
MB	PERMANENT RAISED MARKER, CRYSTAL & RED

COLD APPLIED PLASTIC MARKING SCHEDULE

SYMBOL	DESCRIPTION
CE	WHITE SOLID LANE LINE (4", 120 MIL)
CI	YELLOW DOUBLE CENTER LINE (4", 120 MIL)
DB	RIGHT TURN ARROW (90 MIL)

PLANS PREPARED BY:



DRMP
ENGINEERS · PLANNERS · SCIENTISTS

DRMP, INC.
5650 FAIRVIEW ROAD, SUITE 330
CHARLOTTE, NC 28210
NC LICENSE NO. C-2213 (704) 332-2289

PAVEMENT MARKING PLANS

-L3- STA 307+00 TO -L3- STA 320+00

C:\Users\lms\OneDrive\Work\Projects\W5520_Sgn_PMP_09.dgn
 1/5/2017 14:35
 LISA M. MOON, P.E.
 PROFESSIONAL ENGINEER
 STATE OF NORTH CAROLINA
 LICENSE NO. 022516

★ PROPOSED SIGNAL

PROJECT REFERENCE NO. SHEET NO.
W-5520 PMP-10

APPROVED: Lisa M. Moon

DATE: 9/1/2016

SEAL

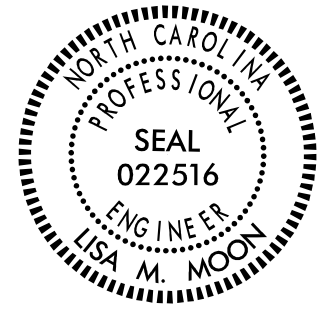

DOCUMENT NOT CONSIDERED FINAL
UNLESS ALL SIGNATURES COMPLETED

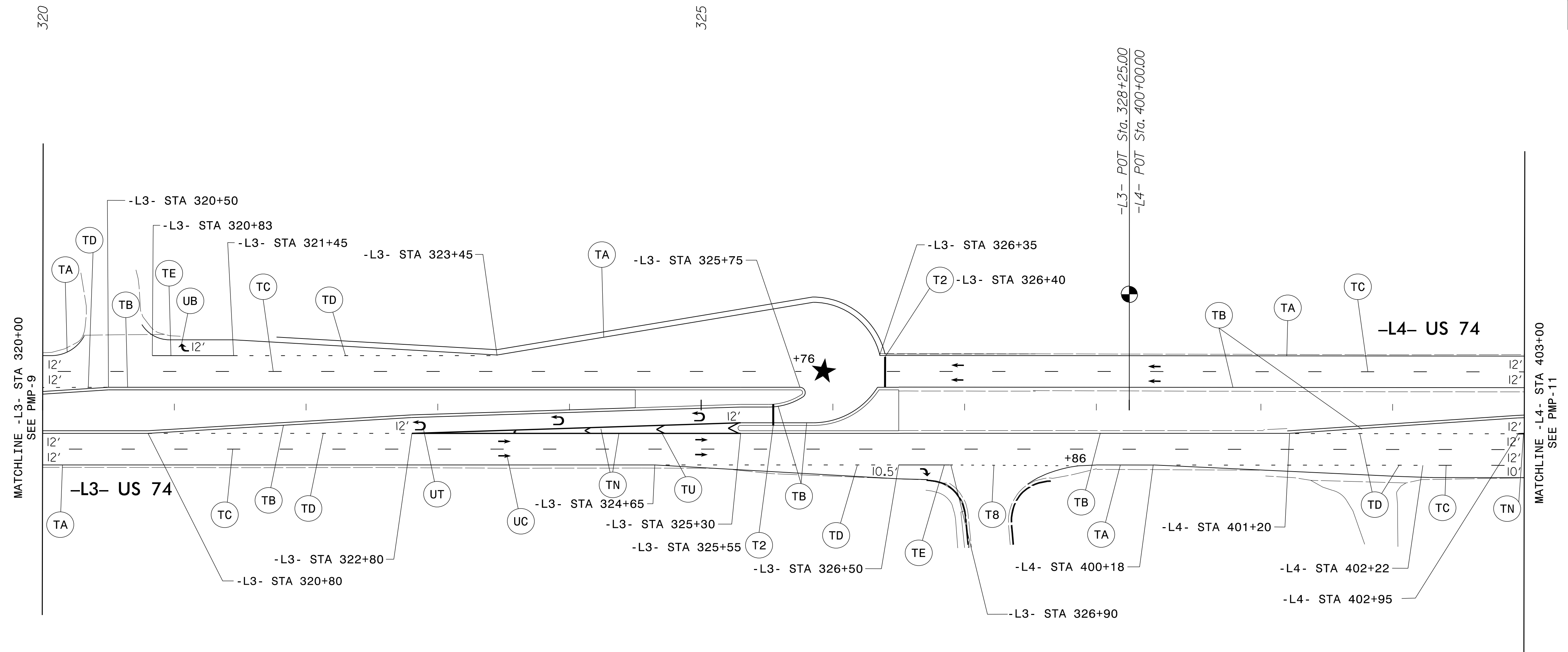
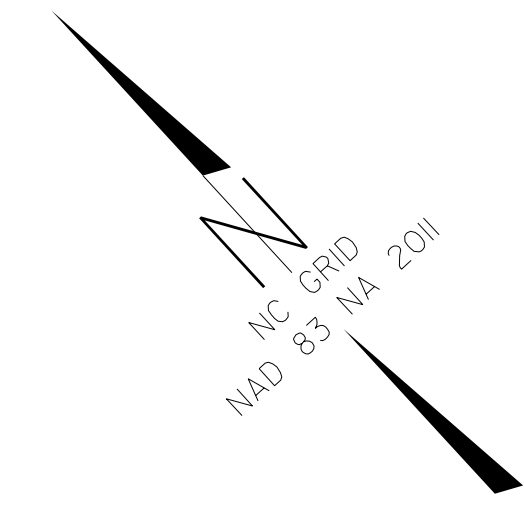

THERMOPLASTIC PAVEMENT MARKING SCHEDULE

SYMBOL	DESCRIPTION
T2	WHITE STOP BAR (24", 120 MIL)
T8	2FT.-6FT./SP WHITE MINISKIP (4", 120 MIL)
T9	2FT.-6FT./SP YELLOW MINISKIP (4", 120 MIL)
TA	WHITE EDGELINE (4", 90 MIL)
TB	YELLOW EDGELINE (4", 90 MIL)
TC	10FT. WHITE SKIP LINE (4" 120 MIL)
TD	3FT.-9FT./SP WHITE MINISKIP (4", 120 MIL)
TE	WHITE SOLID LANE LINE (4", 120 MIL)
TN	WHITE GORELINE (8", 90 MIL)
TU	WHITE DIAGONAL (12", 90 MIL)
UB	RIGHT TURN ARROW (90 MIL)
UC	STRAIGHT ARROW (90 MIL)
UT	U-TURN ARROW (90 MIL)
MB	PERMANENT RAISED MARKER, CRYSTAL & RED

PLANS PREPARED BY:
DRMP
ENGINEERS · PLANNERS · SCIENTISTS

DRMP, INC.
5650 FAIRVIEW ROAD, SUITE 330
CHARLOTTE, NC 28210
NC LICENSE NO. C-2213 (704) 332-2289

PAVEMENT MARKING PLANS
-L3- STA 320+00 TO -L4- STA 403+00

01-SEP-2016 08:10 N:\Projects\W5520\Drawings\CADD\Plan\Marking_Layout\Plans\W5520_Sgn_PMP_10.dgn

★ PROPOSED SIGNAL

PROJECT REFERENCE NO. W-5520	SHEET NO. PMP-11
APPROVED: <i>Lisa M. Moon</i>	
DATE: 9/1/2016	
SEAL	
DOCUMENT NOT CONSIDERED FINAL UNLESS ALL SIGNATURES COMPLETED	

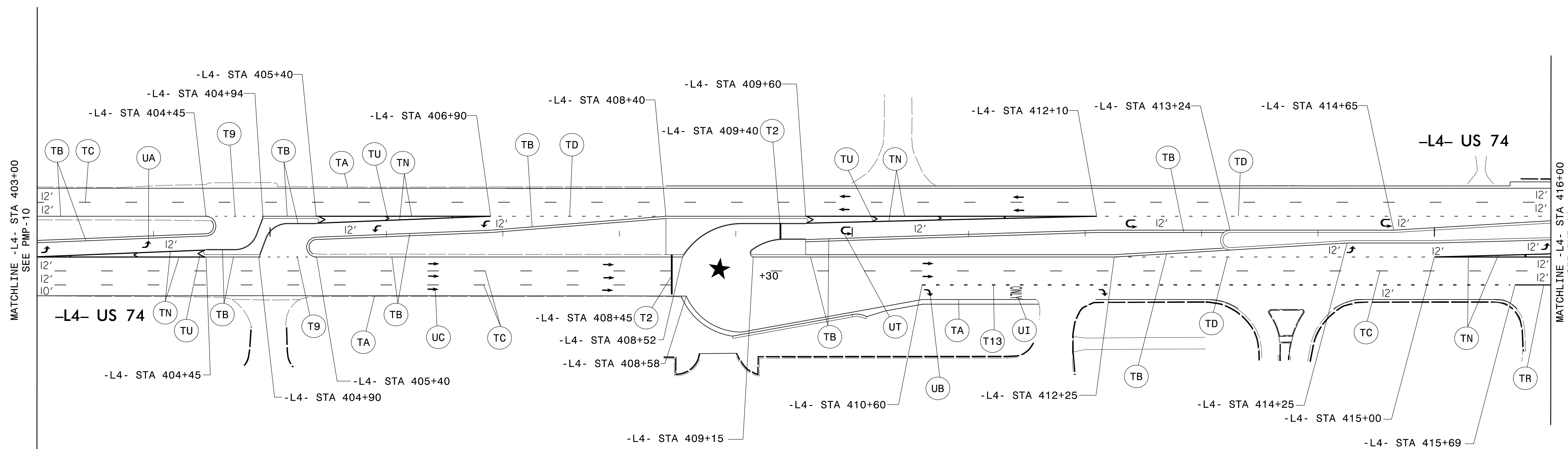
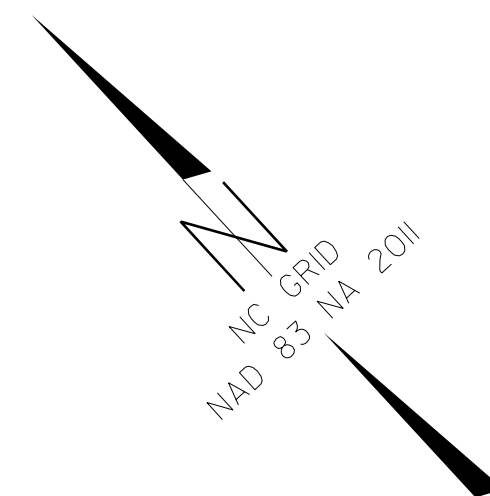

THERMOPLASTIC PAVEMENT MARKING SCHEDULE

SYMBOL	DESCRIPTION
T2	WHITE STOP BAR (24", 120 MIL)
T8	2FT.-6FT./SP WHITE MINISKIP (4", 120 MIL)
T9	2FT.-6FT./SP YELLOW MINISKIP (4", 120 MIL)
T13	3FT.-9FT./SP WHITE MINISKIP (8", 120 MIL)
TA	WHITE EDGELINE (4", 90 MIL)
TB	YELLOW EDGELINE (4", 90 MIL)
TC	10FT. WHITE SKIP LINE (4" 120 MIL)
TD	3FT.-9FT./SP WHITE MINISKIP (4", 120 MIL)
TN	WHITE GORELINE (8", 90 MIL)
TR	WHITE SOLID LANE LINE (8", 120 MIL)
TU	WHITE DIAGONAL (12", 90 MIL)
UA	LEFT TURN ARROW (90 MIL)
UB	RIGHT TURN ARROW (90 MIL)
UC	STRAIGHT ARROW (90 MIL)
UI	ALPHANUMERIC CHAR (120 MIL)
UT	U-TURN ARROW (90 MIL)
MB	PERMANENT RAISED MARKER, CRYSTAL & RED

01-SEP-2016 08:10
 N:\Projects\W5520\Drawings\CADD\Plan\Marking Layout\Plans\W5520_Sgn_PMP_11.dgn
 AT: CAROLINENSEN-W7

PLANS PREPARED BY:

DRMP
ENGINEERS • PLANNERS • SCIENTISTS

DRMP, INC.
5650 FAIRVIEW ROAD, SUITE 330
CHARLOTTE, NC 28210
NC LICENSE NO. C-2213 • (704) 332-2289

PAVEMENT MARKING PLANS
-L3- STA 403+00 TO -L4- STA 416+00

★ PROPOSED SIGNAL

CURB RAMP STATION*	CURB RAMP TYPE
7 -L1- STA 418+16, 72'RT	STANDARD
*CENTERLINE OF RAMP AT FACE OF CURB	

PROJECT REFERENCE NO. W-5520	SHEET NO. PMP-12
APPROVED: Lisa M. Moon	
DATE: 9/1/2016	
SEAL	
DOCUMENT NOT CONSIDERED FINAL UNLESS ALL SIGNATURES COMPLETED	

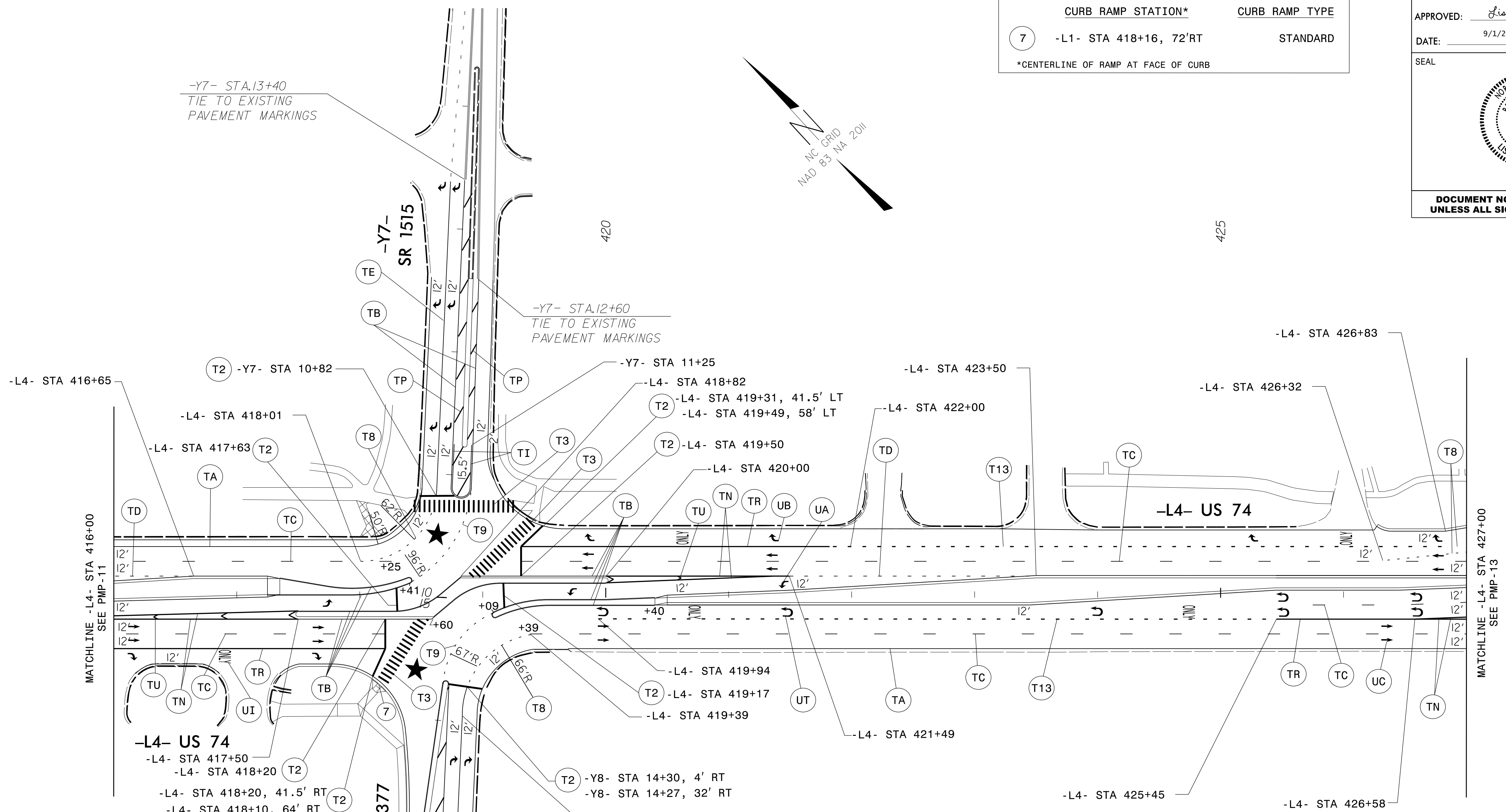

THERMOPLASTIC PAVEMENT MARKING SCHEDULE

SYMBOL	DESCRIPTION
T2	WHITE STOP BAR (24", 120 MIL)
T3	WHITE CROSSWALK LINE (24", 120 MIL)
T8	2FT.-6FT./SP WHITE MINISKIP (4", 120 MIL)
T9	2FT.-6FT./SP YELLOW MINISKIP (4", 120 MIL)
T13	3FT.-9FT./SP WHITE MINISKIP (8", 120 MIL)
TA	WHITE EDGELINE (4", 90 MIL)
TB	YELLOW EDGELINE (4", 90 MIL)
TC	10FT. WHITE SKIP LINE (4" 120 MIL)
TD	3FT.-9FT./SP WHITE MINISKIP (4", 120 MIL)
TE	WHITE SOLID LANE LINE (4", 120 MIL)
TI	YELLOW DOUBLE CENTER LINE (4", 120 MIL)
TN	WHITE GORELINE (8", 90 MIL)
TP	YELLOW DIAGONAL (8", 90 MIL)
TR	WHITE SOLID LANE LINE (8", 120 MIL)
TU	WHITE DIAGONAL (12", 90 MIL)
UA	LEFT TURN ARROW (90 MIL)
UB	RIGHT TURN ARROW (90 MIL)
UC	STRAIGHT ARROW (90 MIL)
UI	ALPHANUMERIC CHAR (120 MIL)
UT	U-TURN ARROW (90 MIL)
MA	PERMANENT RAISED MARKER, YELLOW & YELLOW
MB	PERMANENT RAISED MARKER, CRYSTAL & RED

PLANS PREPARED BY:

DRMP
ENGINEERS · PLANNERS · SCIENTISTS

DRMP, INC.
5650 FAIRVIEW ROAD, SUITE 330
CHARLOTTE, NC 28210
NC LICENSE NO. C-2213 • (704) 332-2289

PAVEMENT MARKING PLANS
-L4- STA 416+00 TO -L4- STA 427+00

01-SEP-2016 08:10 N:\Projects\W5520\Drawings\Marking Layout\Plans\W5520_Sgn_PMP_12.dgn AT: CARPENTIER, WY

★ PROPOSED SIGNAL

PROJECT REFERENCE NO. W-5520	SHEET NO. PMP-13
APPROVED: <i>Lisa M. Moon</i>	
DATE: 9/1/2016	
SEAL	
	
DOCUMENT NOT CONSIDERED FINAL UNLESS ALL SIGNATURES COMPLETED	

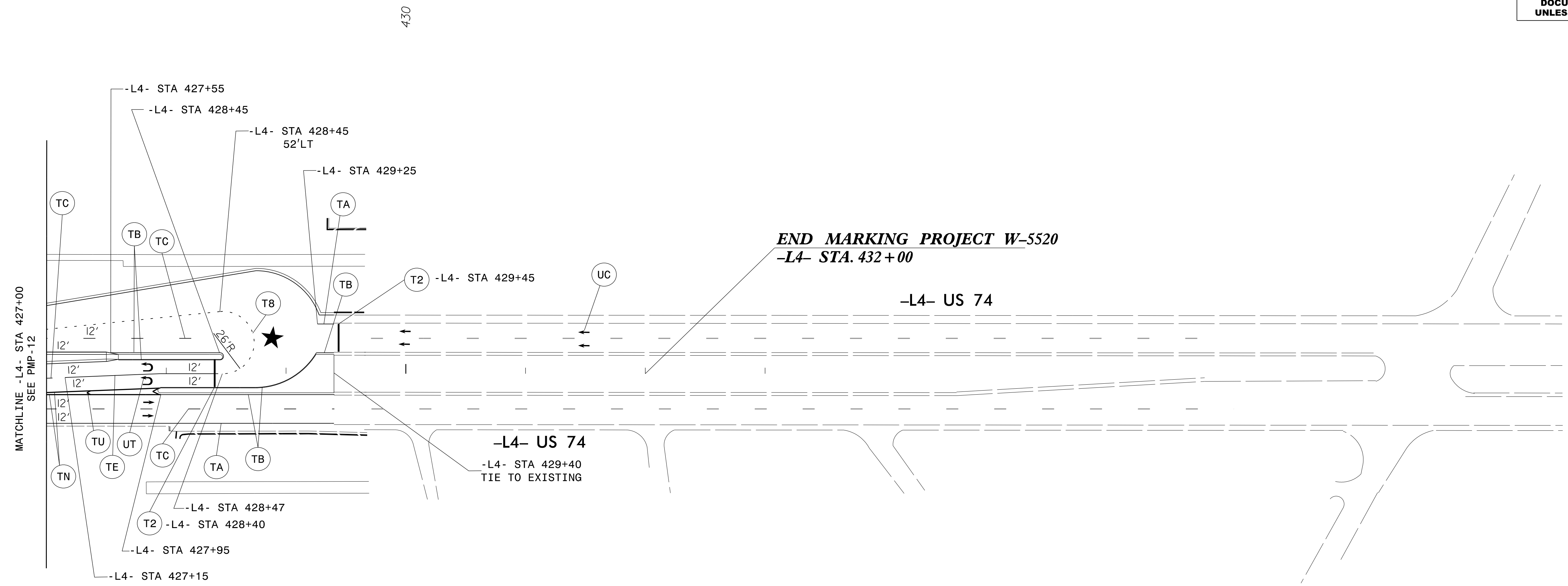
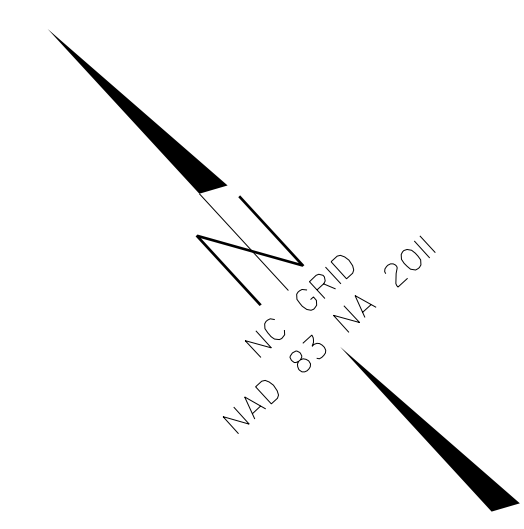

THERMOPLASTIC PAVEMENT MARKING SCHEDULE

SYMBOL	DESCRIPTION
T2	WHITE STOP BAR (24", 120 MIL)
T8	2FT.-6FT./SP WHITE MINISKIP (4", 120 MIL)
TA	WHITE EDGELINE (4", 90 MIL)
TB	YELLOW EDGELINE (4", 90 MIL)
TC	10FT. WHITE SKIP LINE (4" 120 MIL)
TE	WHITE SOLID LANE LINE (4", 120 MIL)
TN	WHITE GORELINE (8", 90 MIL)
TU	WHITE DIAGONAL (12", 90 MIL)
UC	STRAIGHT ARROW (90 MIL)
UT	U-TURN ARROW (90 MIL)
MB	PERMANENT RAISED MARKER, CRYSTAL & RED

PLANS PREPARED BY:
 **DRMP**
 ENGINEERS • PLANNERS • SCIENTISTS

PAVEMENT MARKING PLANS
 -L4- STA 427+00 TO -L4- STA 432+00

DRMP, INC.
 5650 FAIRVIEW ROAD, SUITE 330
 CHARLOTTE, NC 28210
 NC LICENSE NO. C-2213 • (704) 332-2289

01-SEP-2016 08:10
 N:\Projects\W5520\Drawings\CADD\Plan\Marking Layout\Plans\W5520_Sgn_PMP_13.dgn
 AT: CLARENCE