

PHASING DIAGRAM

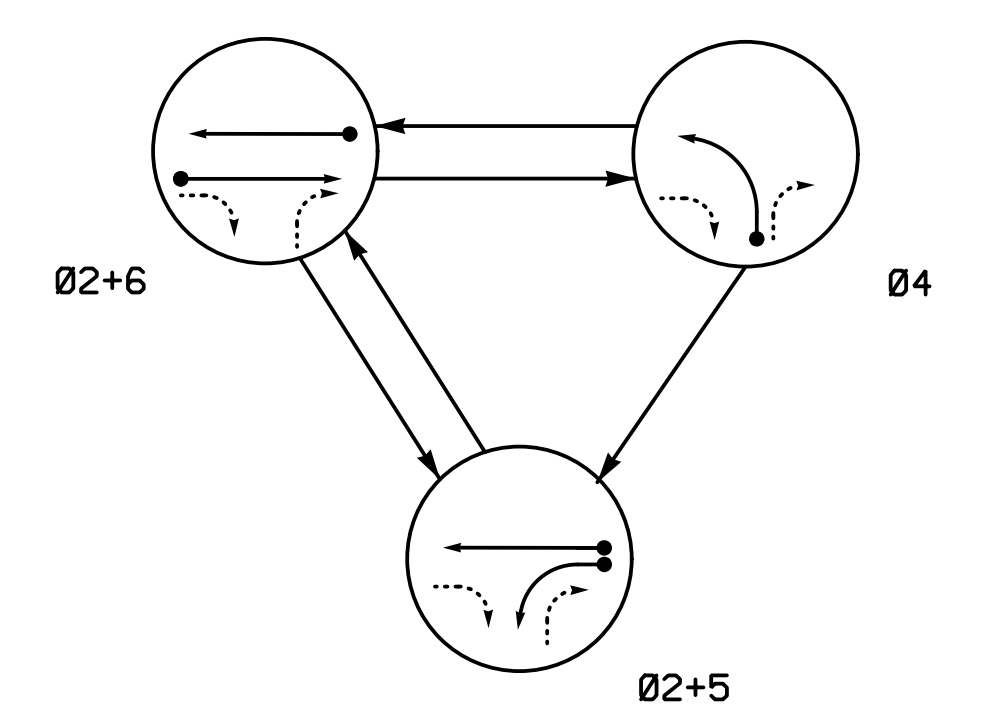

PHASING DIAGRAM DETECTION LEGEND

- ←● DETECTED MOVEMENT
- ← UNDETECTED MOVEMENT (OVERLAP)
- ← UN SIGNALIZED MOVEMENT
- ← PEDESTRIAN MOVEMENT

SIGNAL FACE	PHASE			
	Ø 2+5	Ø 2+6	Ø 4	FLASH
21,22	G	G	R	Y
41,42	R	R	-	R
51	-	R	R	R
61,62	R	G	R	Y

SIGNAL FACE I.D.

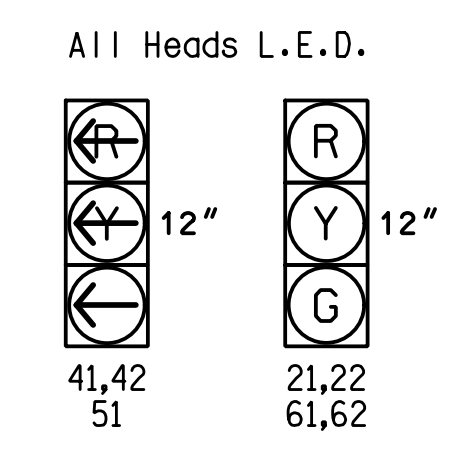

OASIS 2070 LOOP & DETECTOR INSTALLATION CHART												
INDUCTIVE LOOPS					DETECTOR PROGRAMMING							
LOOP	SIZE (FT)	DISTANCE FROM STOPBAR (FT)	TURNS	NEW LOOP	PHASE	CALLING	EXTENSION	FULL TIME DELAY	STRETCH TIME	DELAY TIME	SYSTEM LOOP	NEW CARD
2A/S1	6X6	300	6	Y	2	Y	Y	-	-	-	Y	-
4A	6X60	0	2-4-2	-	4	Y	Y	-	-	-	-	-
5A	6X40	0	2-4-2	Y	5	Y	Y	-	-	-	-	-
6A/S2	6X6	300	4	-	6	Y	Y	-	-	-	Y	-

3 Phase Fully Actuated (Gastonia City Signal System)

NOTES

- Refer to "Roadway Standard Drawings NCDOT" dated January 2012 and "Standard Specifications for Roads and Structures" dated January 2012.
- Do not program signal for late night flashing operation unless otherwise directed by the Engineer.
- Phase 5 may be lagged.
- Reposition signal heads 21,22, 41,42,51,61,62, and signs A and C.
- Set all detector units to presence mode.
- Maximum times shown in timing chart are for free-run operation only. Coordinated signal system timing values supersede these values.
- Signal System Data: Controller Asset #0162.

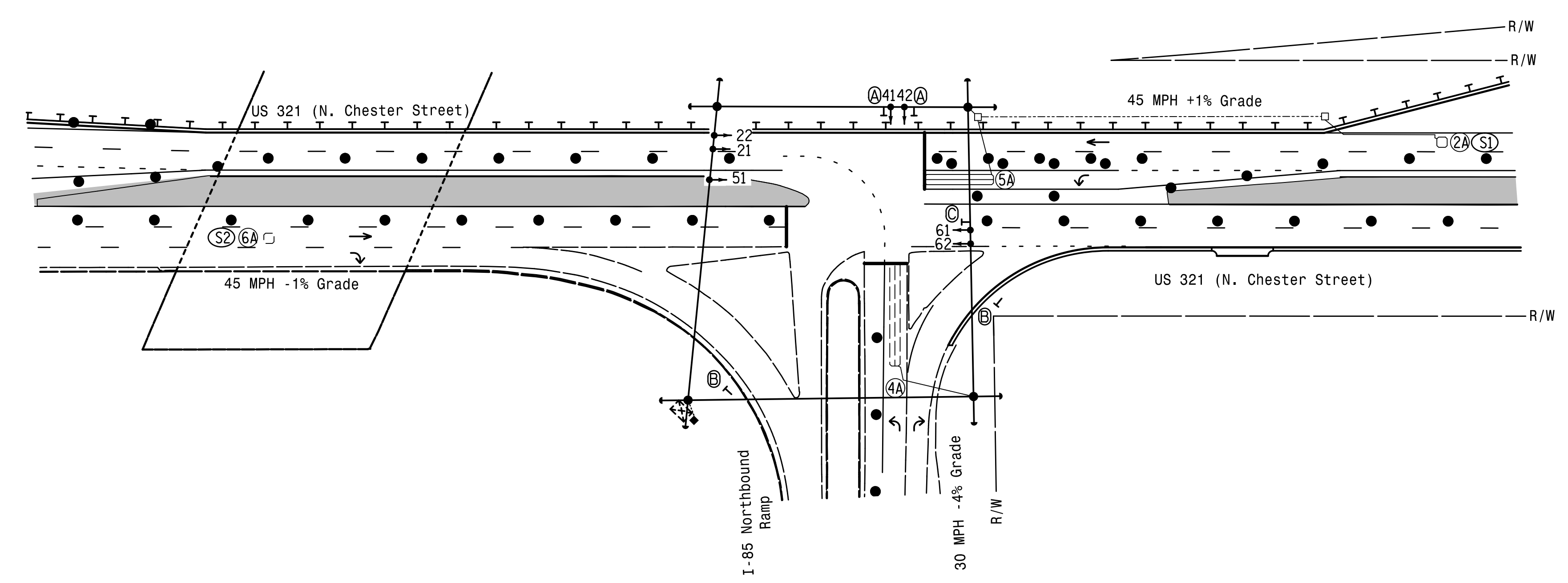

OASIS 2070 TIMING CHART

FEATURE	PHASE			
	2	4	5	6
Min Green 1 *	12	7	7	12
Extension 1 *	6.0	1.0	2.0	6.0
Max Green 1 *	90	25	15	90
Yellow Clearance	4.4	3.0	3.0	4.6
Red Clearance	1.1	3.1	2.6	1.1
Red Revert	2.0	2.0	2.0	2.0
Walk 1 *	-	-	-	-
Don't Walk 1	-	-	-	-
Seconds Per Actuation *	2.5	-	-	2.5
Max Variable Initial *	34	-	-	34
Time Before Reduction *	15	-	-	15
Time To Reduce *	30	-	-	30
Minimum Gap	3.0	-	-	3.0
Recall Mode	MIN RECALL	-	-	MIN RECALL
Vehicle Call Memory	YELLOW	-	-	YELLOW
Dual Entry	-	-	-	-
Simultaneous Gap	ON	ON	ON	ON

* These values may be field adjusted. Do not adjust Min Green and Extension times for phases 2 and 6 lower than what is shown. Min Green for all other phases should not be lower than 4 seconds.

PROPOSED		EXISTING	
○→	Traffic Signal Head	●→	N/A
●→	Modified Signal Head	-	N/A
↓	Sign	↓	N/A
□→	Pedestrian Signal Head With Push Button & Sign	□→	N/A
○→	Signal Pole with Guy	●→	N/A
○→	Signal Pole with Sidewalk Guy	●→	N/A
□	Inductive Loop Detector	□	N/A
□	Controller & Cabinet	□	N/A
□	Junction Box	□	N/A
---	2-in Underground Conduit	---	N/A
N/A	Right of Way	---	N/A
→	Directional Arrow	→	N/A
N/A	Guardrail	---	N/A
A	Left Arrow "ONLY" Sign (R3-5L)	A	N/A
B	"YIELD" Sign (R1-2)	B	N/A
C	No U-Turn Sign (R3-4)	C	N/A
■	Construction Zone	■	N/A
●	Construction Zone Drums	●	N/A

Temporary Signal Phase 1, Steps 6 & 7

DOCUMENT NOT CONSIDERED FINAL UNLESS ALL SIGNATURES COMPLETED

HNTB HNTB NORTH CAROLINA, P.C.
343 E. Six Forks Road, Suite 200
Raleigh, North Carolina 27609
NC License No: C-1554
(919) 546-8997

Prepared for
TRANSFORMATION MOBILITY AND SAFETY
STATE OF NORTH CAROLINA
DEPARTMENT OF TRANSPORTATION
Signal Design Section

750 N. Greenfield Pkwy, Garner, NC 27529

SCALE
0 50
1"=50'

US 321 (N. Chester Street) at I-85 Northbound Ramp

Division 12 Gaston Co. Gastonia

PLAN DATE: September 2016 REVIEWED BY: T.R. Terrell

PREPARED BY: J.A. Wagner REVIEWED BY: N.R. Simmons

REVISIONS	INIT.	DATE

SEAL
NORTH CAROLINA PROFESSIONAL ENGINEER
SEAL 031464
NATASHA R. SIMMONS
ENGINEER

DocuSigned by:
Natasha R. Simmons
11/8/2016
SIGNATURE DATE
SIG. INVENTORY NO. 12-0162T3