

DOCUMENT NOT CONSIDERED FINAL UNLESS ALL SIGNATURES COMPLETED

-RPA-

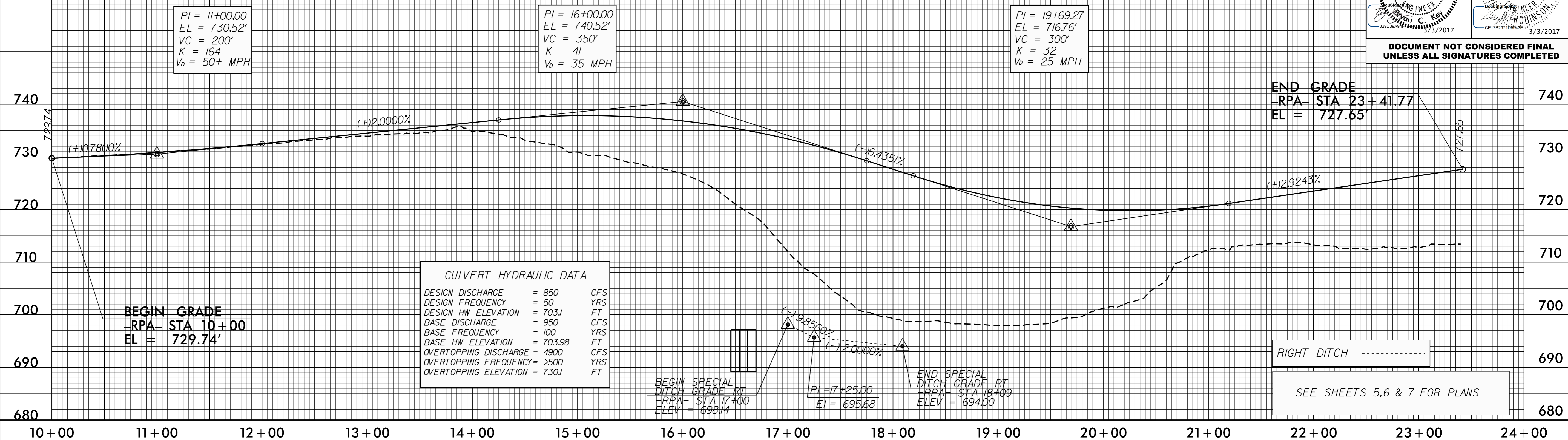

-RPD-

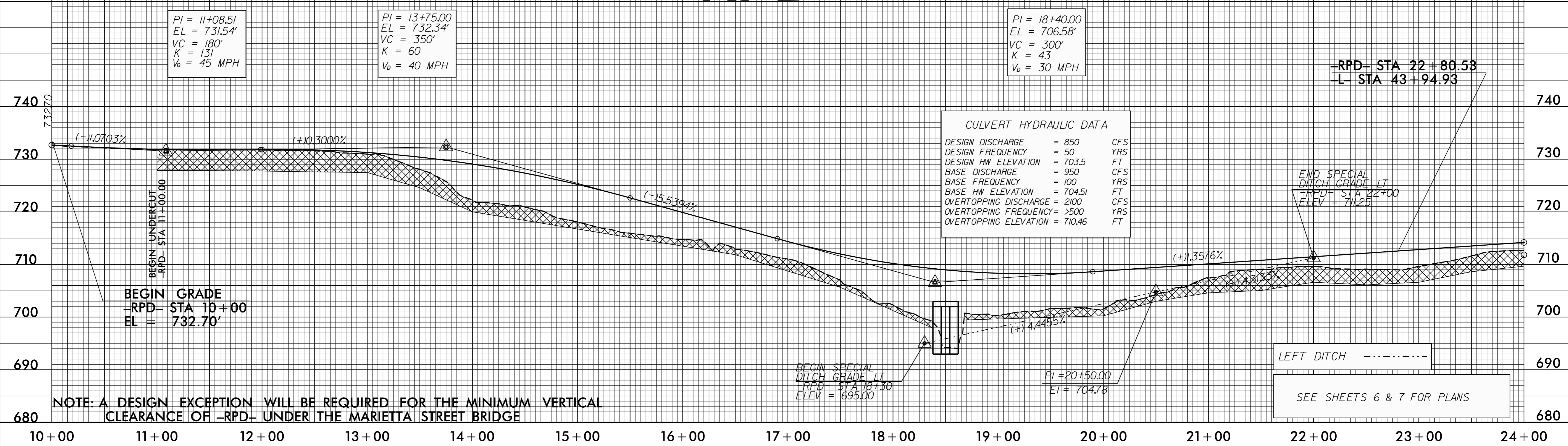

NOTE: A DESIGN EXCEPTION WILL BE REQUIRED FOR THE MINIMUM VERTICAL CLEARANCE OF -RPD- UNDER THE MARIETTA STREET BRIDGE

5/28/99
19-JAN-2017 16:37 A:\1-5000-RD-RPA-RPD.dgn
5:53:50 PM
C:\PROGRAMS\AUTOCAD\ACAD