

**This electronic collection of documents is provided
for the convenience of the user
and is Not a Certified Document –**

**The documents contained herein were originally issued
and sealed by the individuals whose names and license
numbers appear on each page, on the dates appearing
with their signature on that page.**

**This file or an individual page
shall not be considered a certified document.**

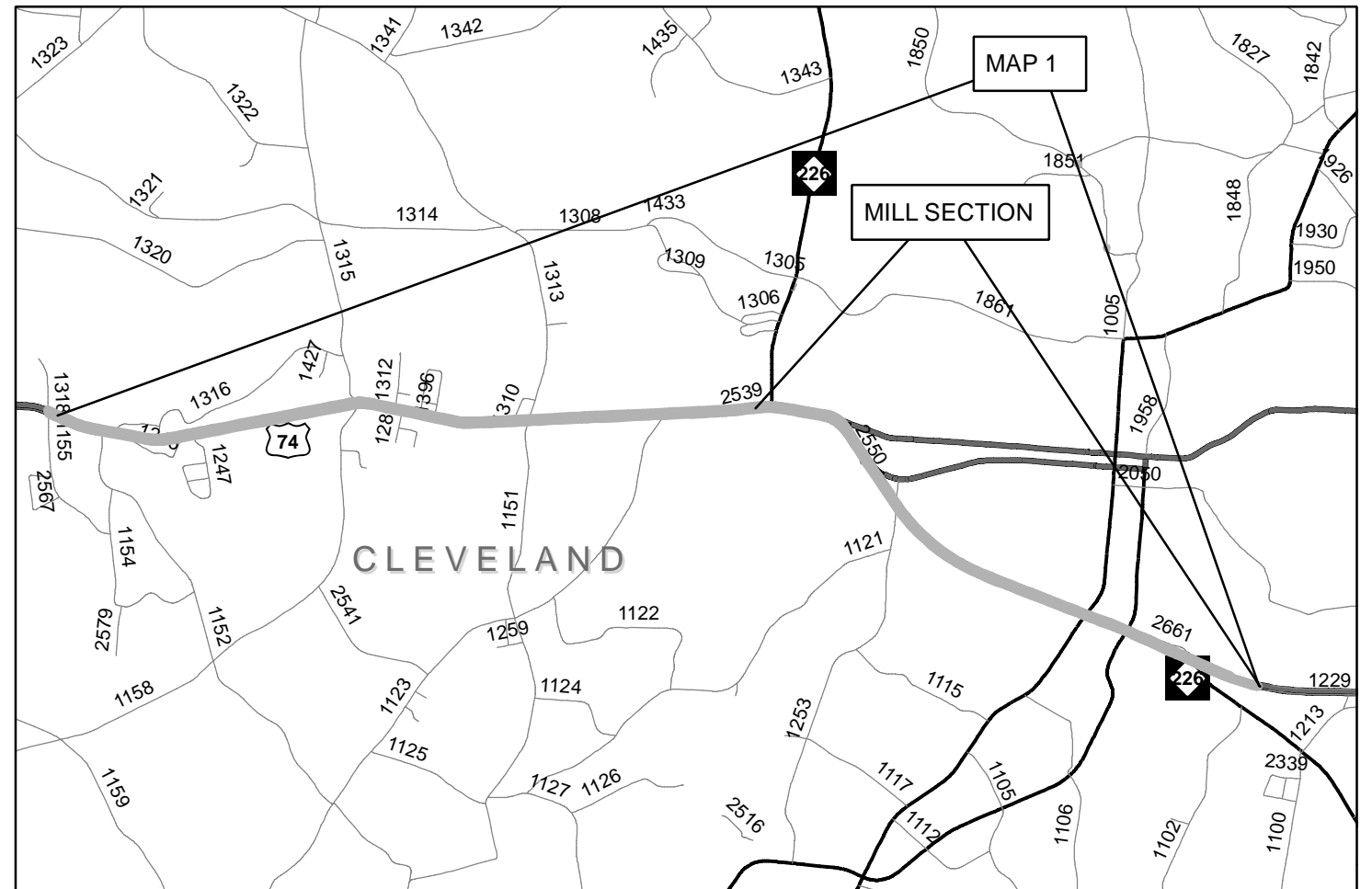

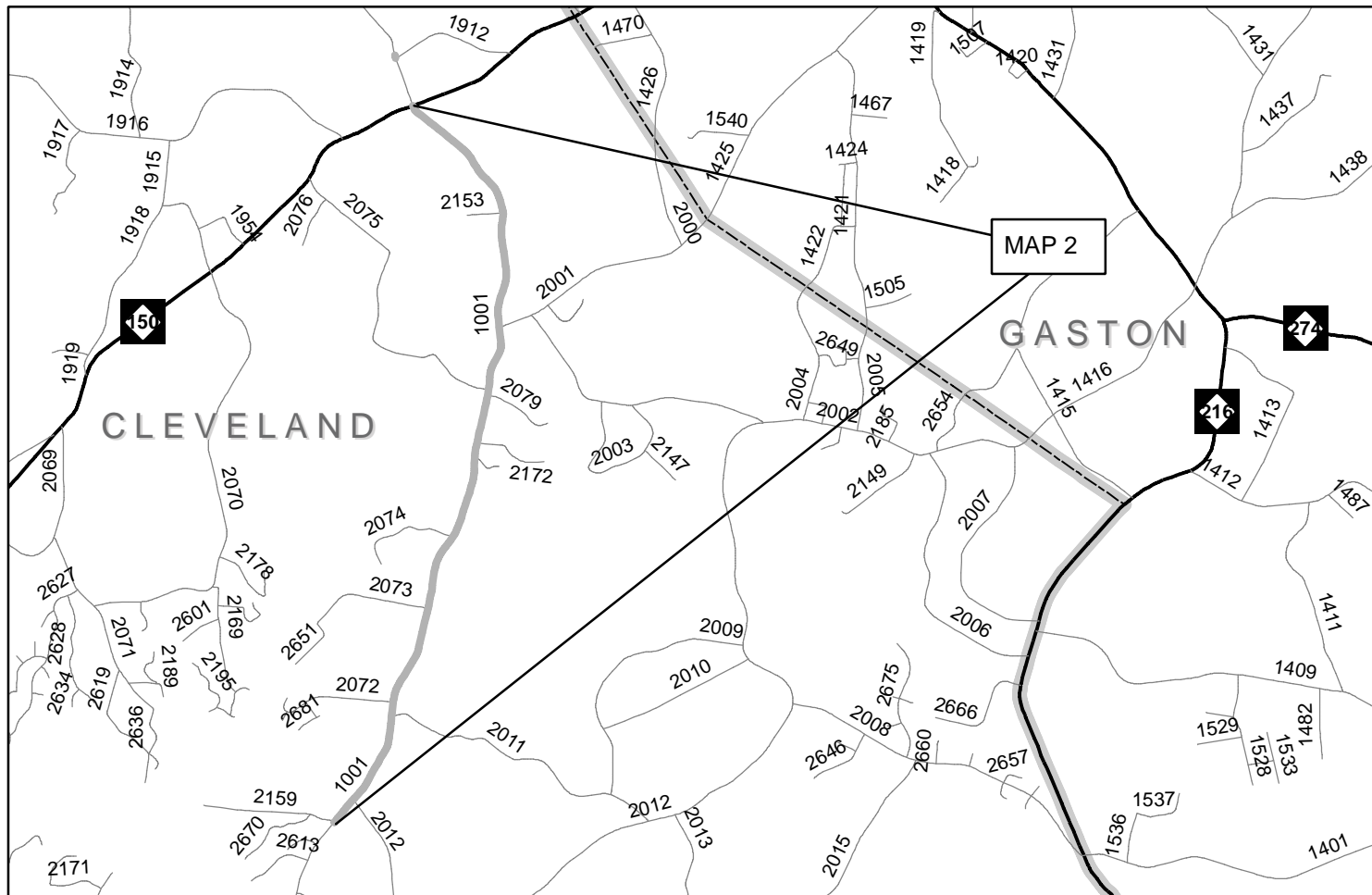
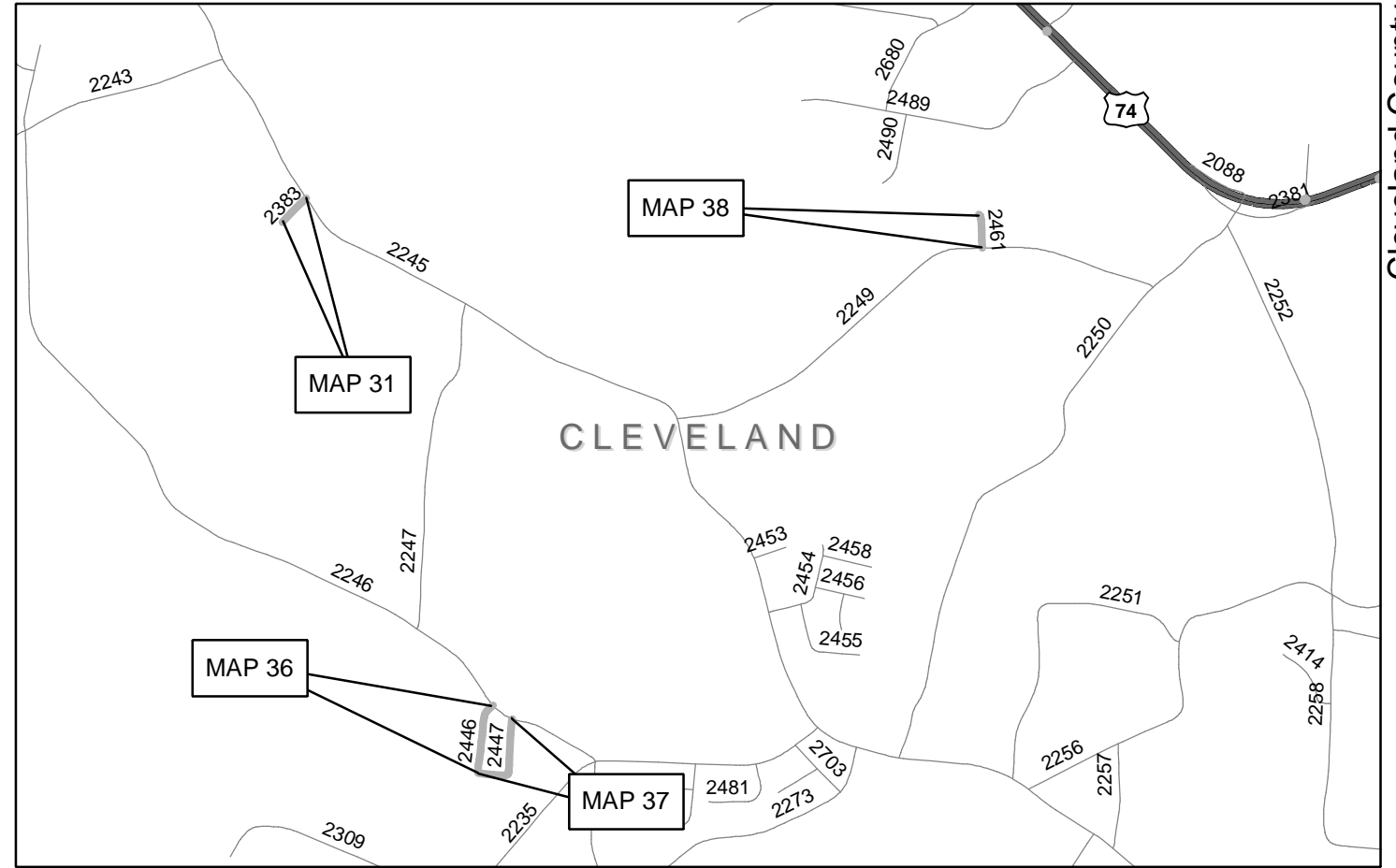
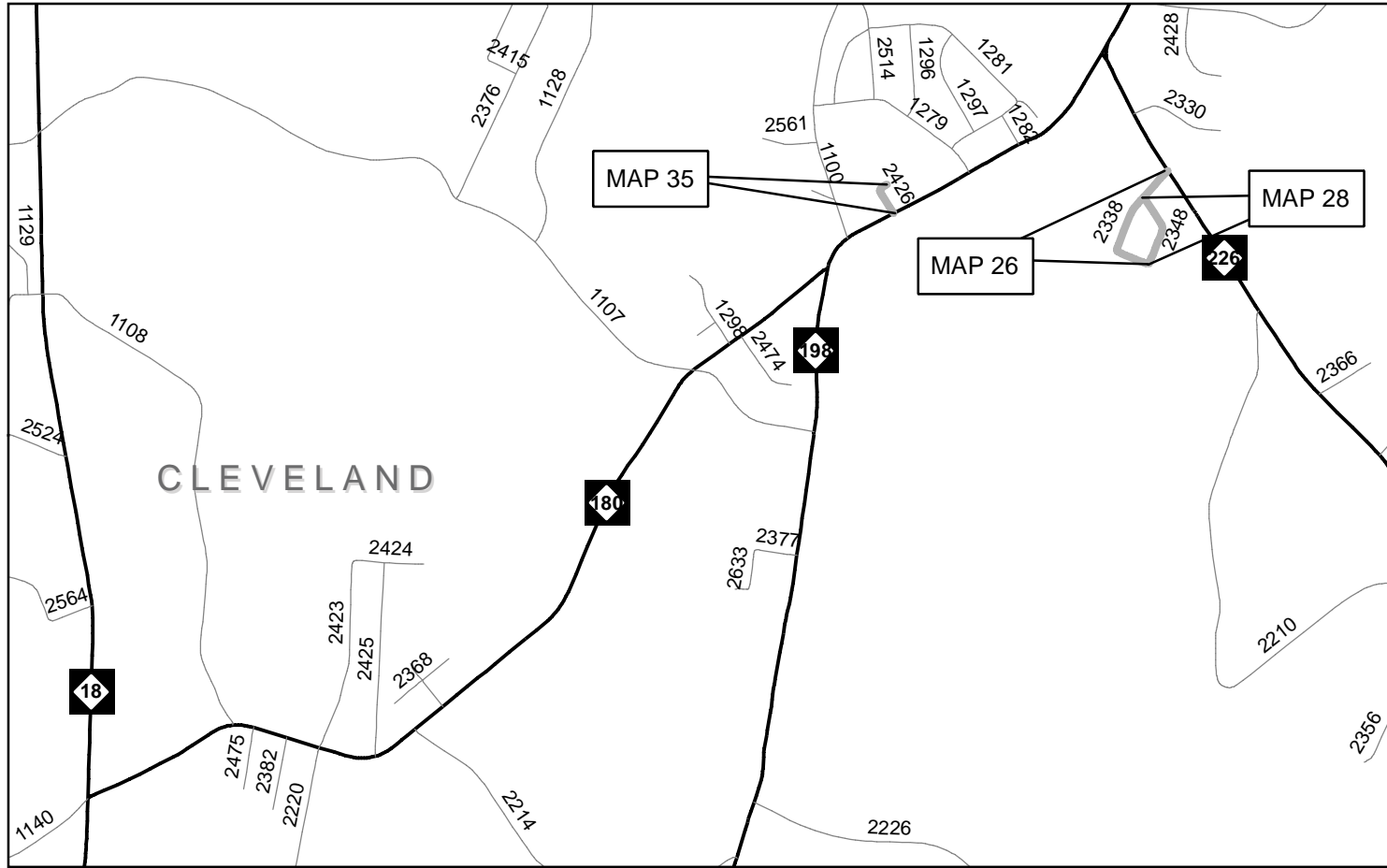
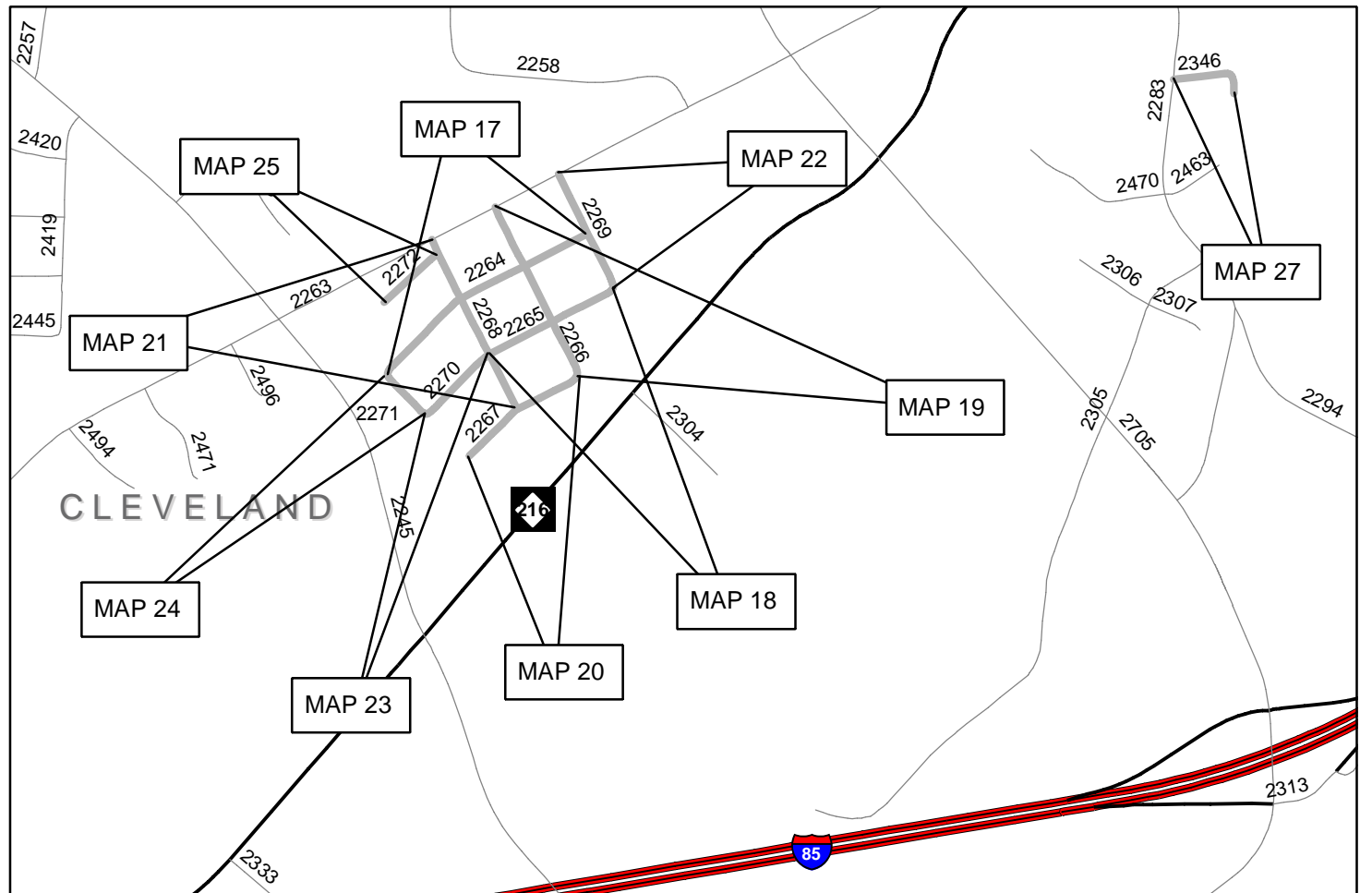
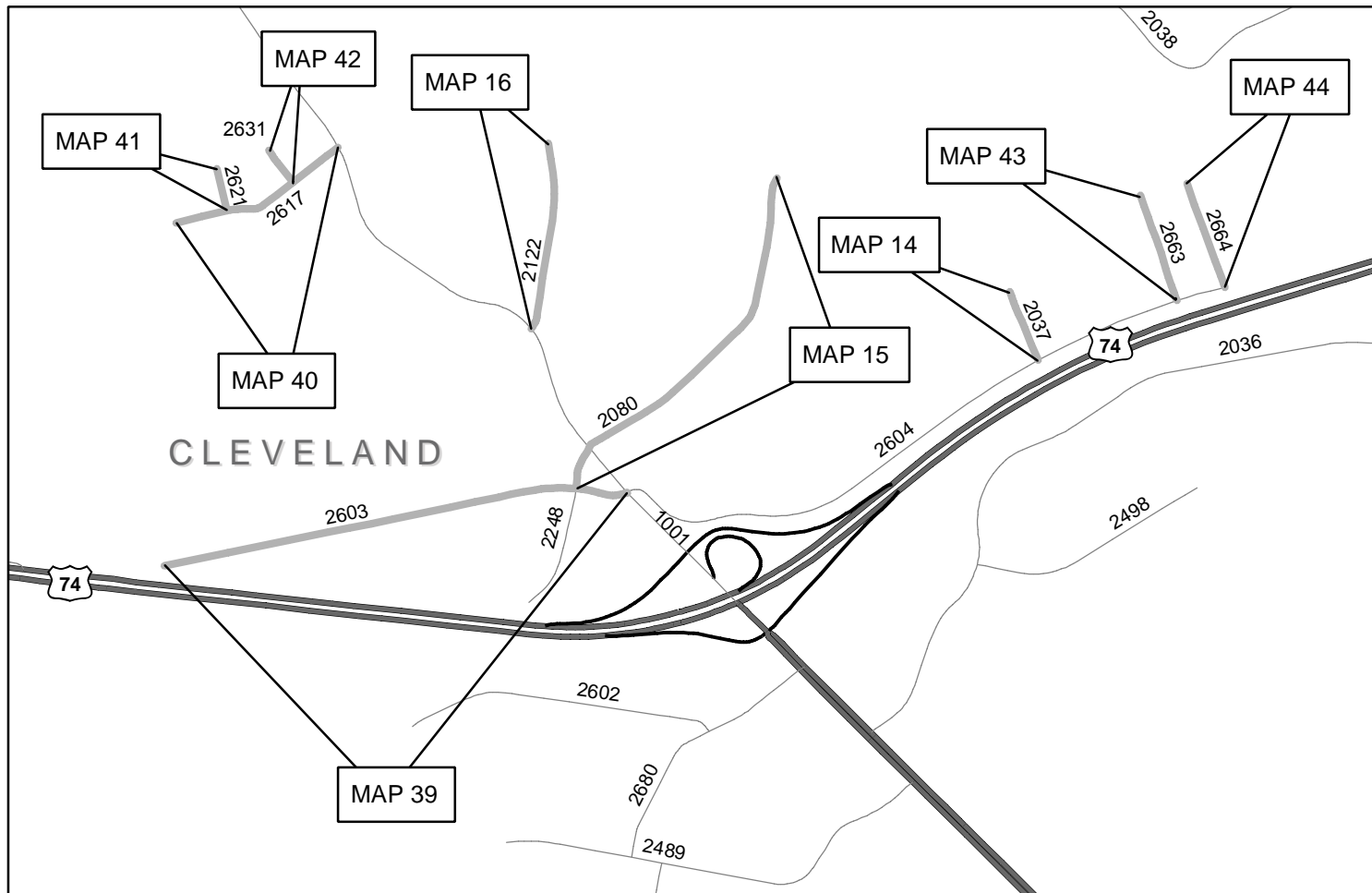
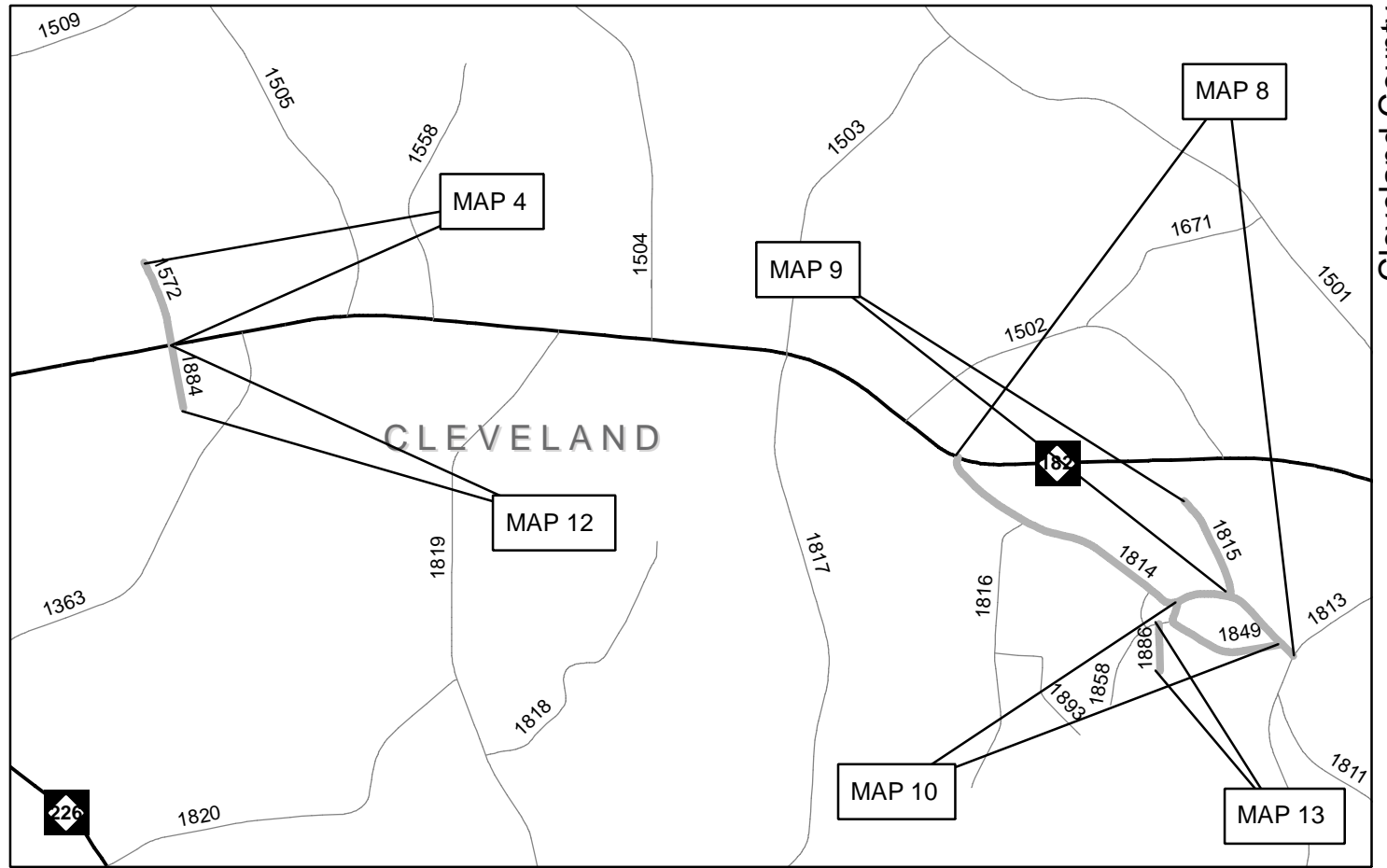
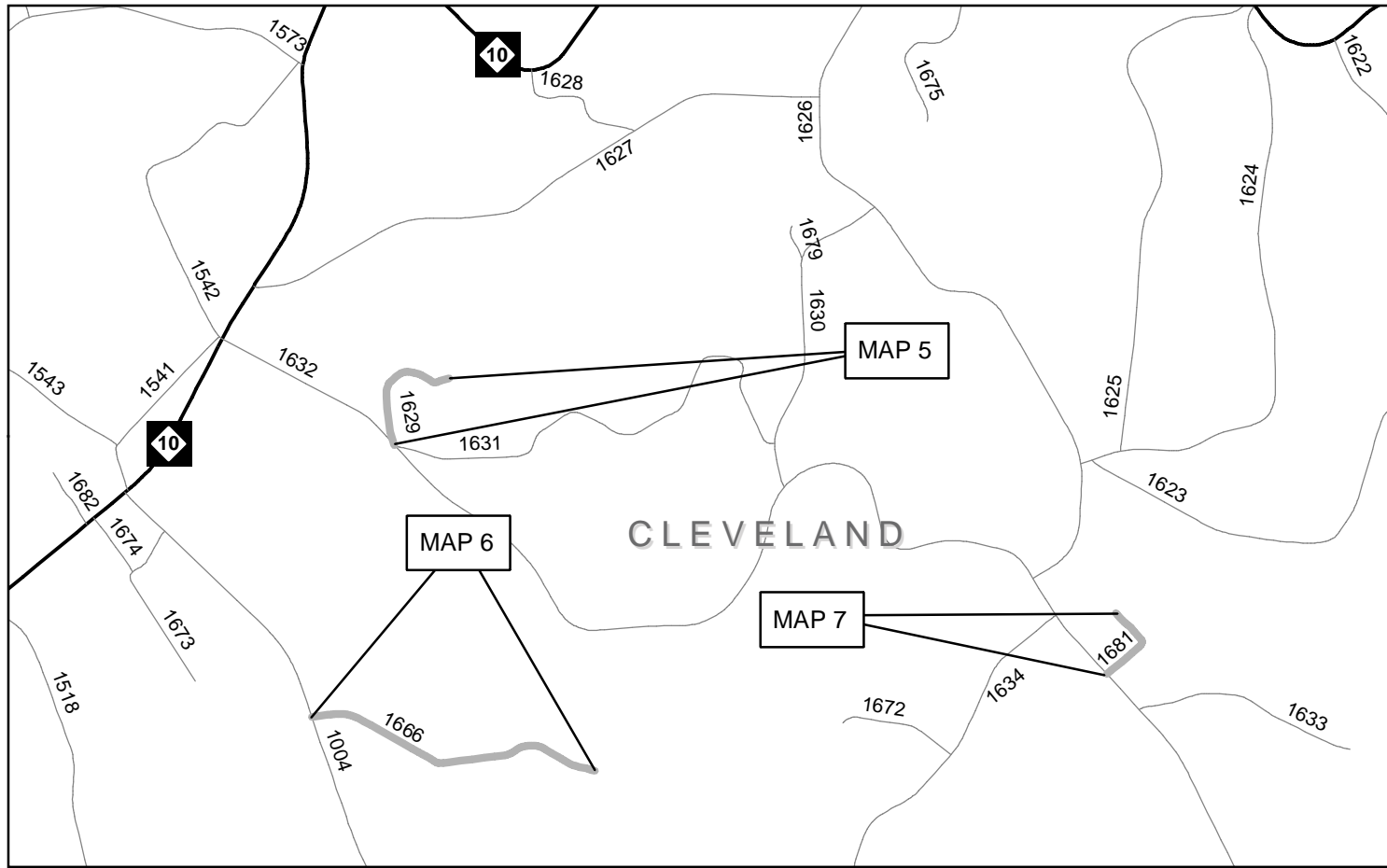

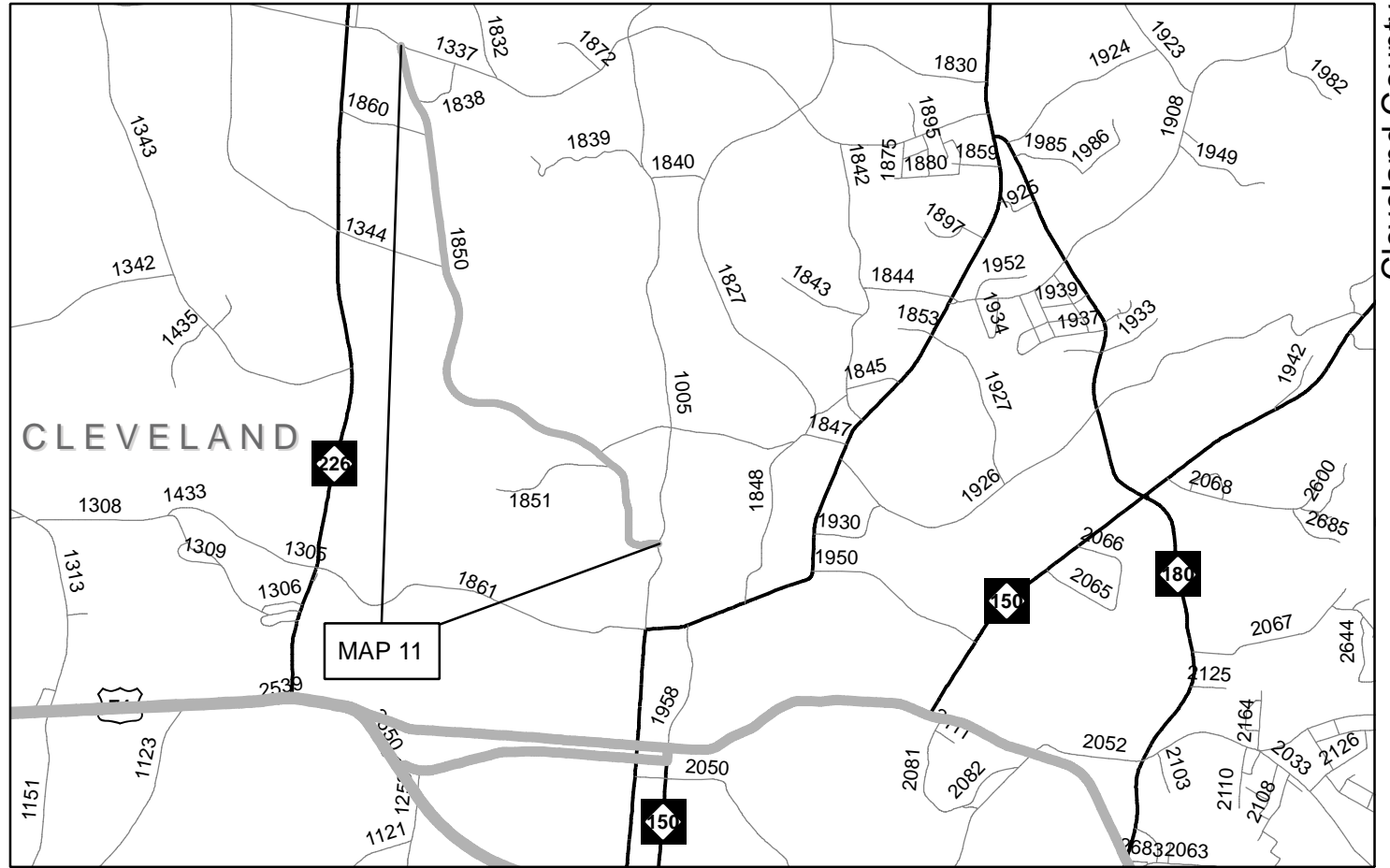
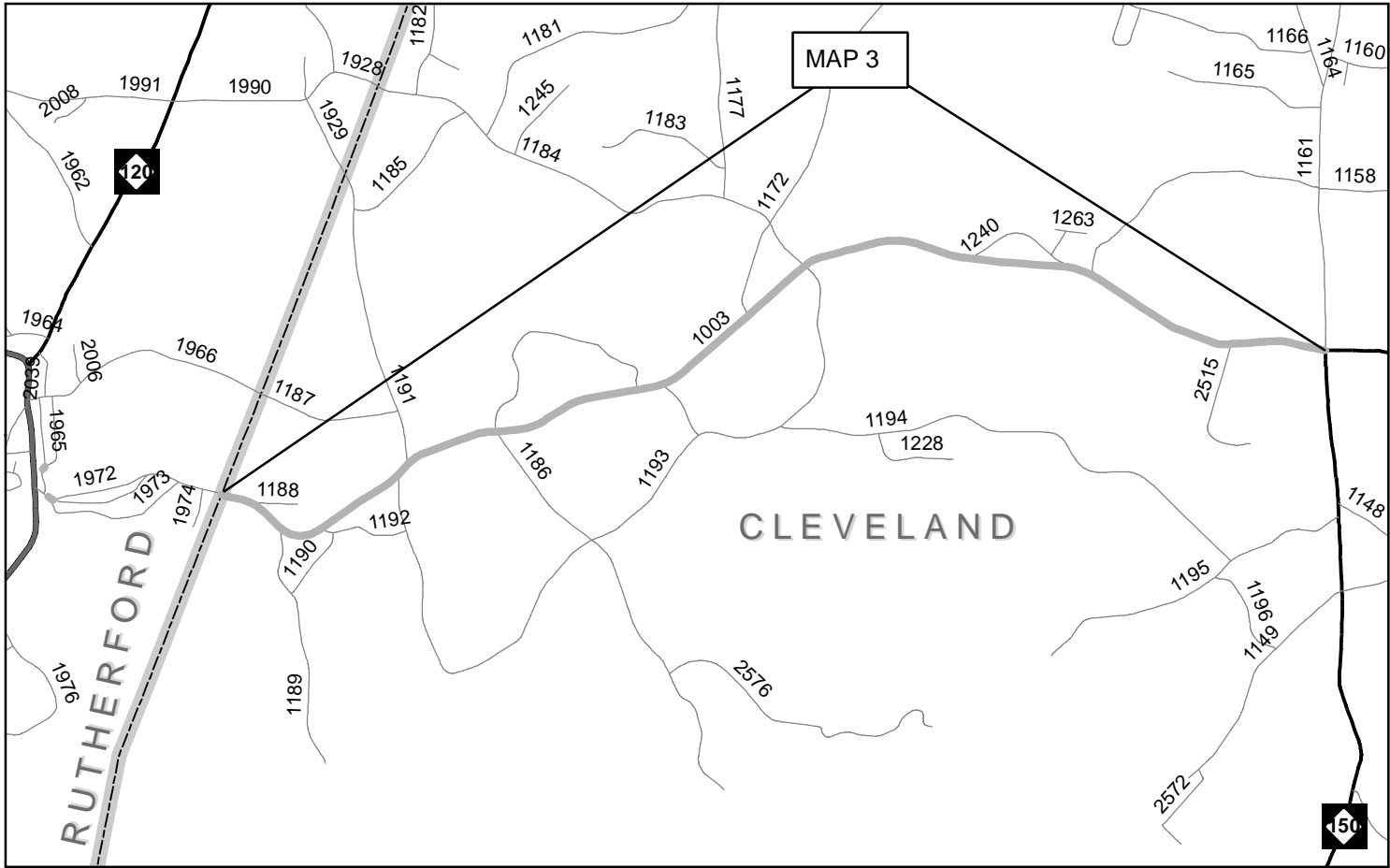

Cleveland County
WBS# 2017CPT.12.18.10231
WBS# 2017CPT.12.18.20231

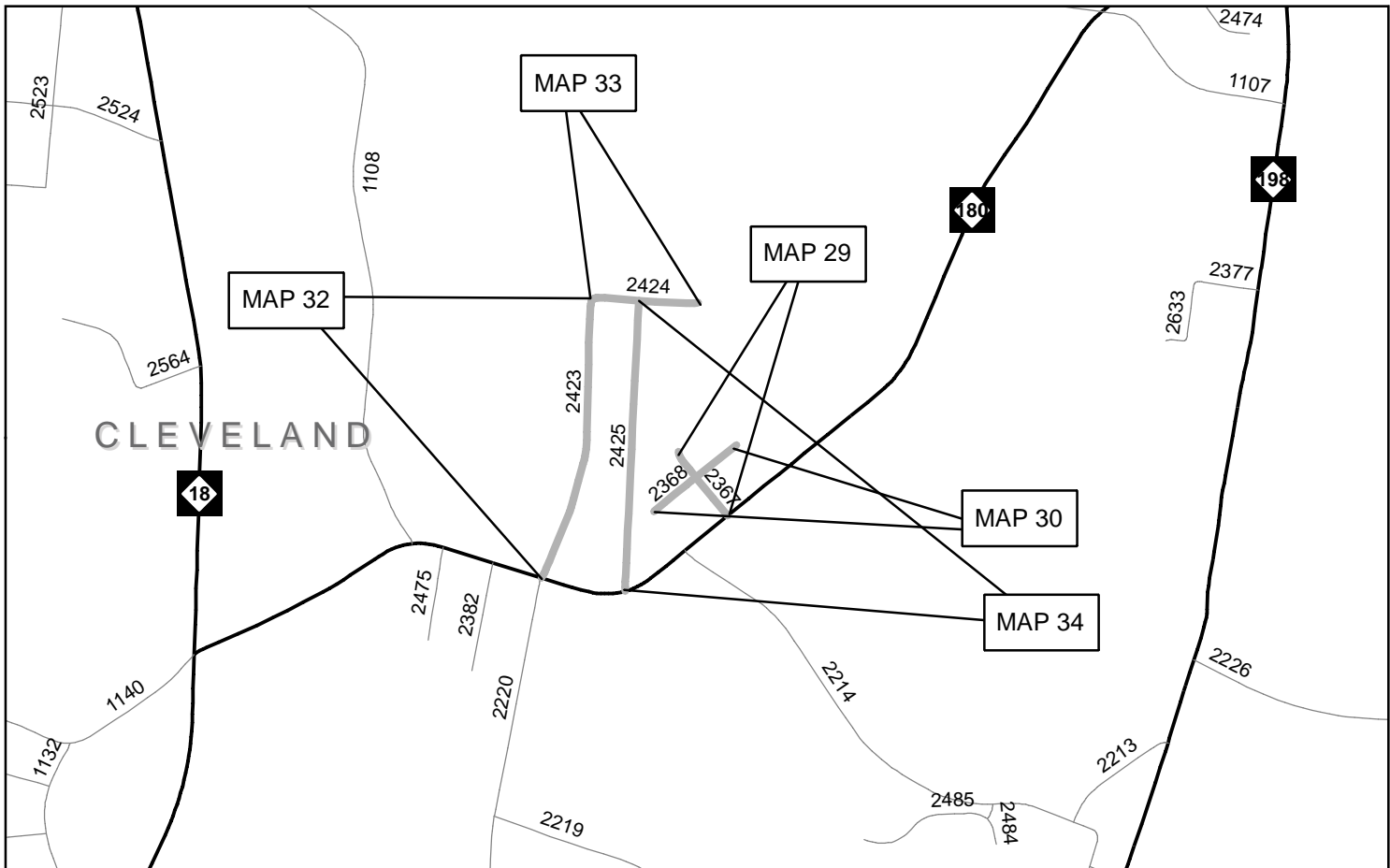

PAVEMENT SCHEDULE	
Y	SHOULDER RECONSTRUCTION (ASB)
C1	PROP. APPROX. 1½" ASPHALT CONCRETE SURFACE COURSE, TYPE S9.5B, AT AN AVERAGE RATE OF 168 LBS. PER SQ. YD.
C2	PROP. APPROX. 1½" ASPHALT CONCRETE SURFACE COURSE, TYPE S9.5C, AT AN AVERAGE RATE OF 168 LBS. PER SQ. YD.
C3	PROP. APPROX. 1" ASPHALT CONCRETE SURFACE COURSE, TYPE SF9.5A, AT AN AVERAGE RATE OF 110 LBS. PER SQ. YD.
E1	PROP. APPROX. 5.5" ASPHALT CONCRETE BASE COURSE, TYPE B25.0B, AT AN AVERAGE RATE OF 627 LBS. PER SQ. YD.
V1	MILL ASPHALT PAVEMENT APPROX. 1½" AS DIRECTED BY THE ENGINEER.
Z	INCIDENTAL MILLING AS DIRECTED BY THE ENGINEER.

NOTE: PAVEMENT EDGE SLOPES ARE 1:1 UNLESS SHOWN OTHERWISE.

MILL BRIDGE APPROACHES 100' TO PROVIDE A SMOOTH TRANSITION AS DIRECTED.

MILL INTO GUTTER LINE WHERE SHOWN AND AS DIRECTED.

MAINTAIN PROPER CROWN FOR DRAINAGE OF THE ROAD SURFACE.

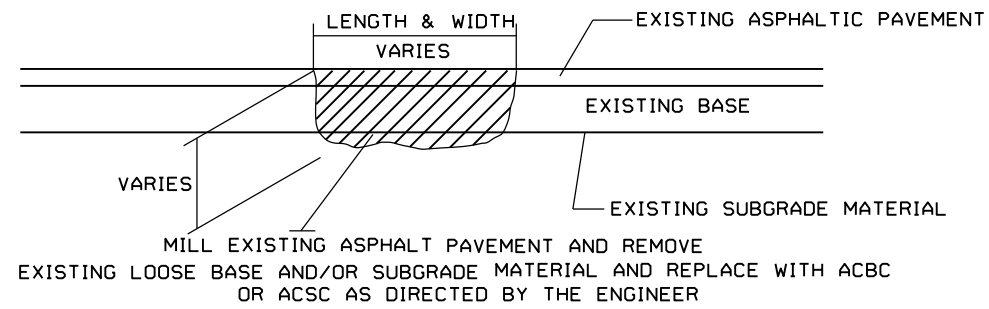

PATCHING EXISTING PAVEMENT

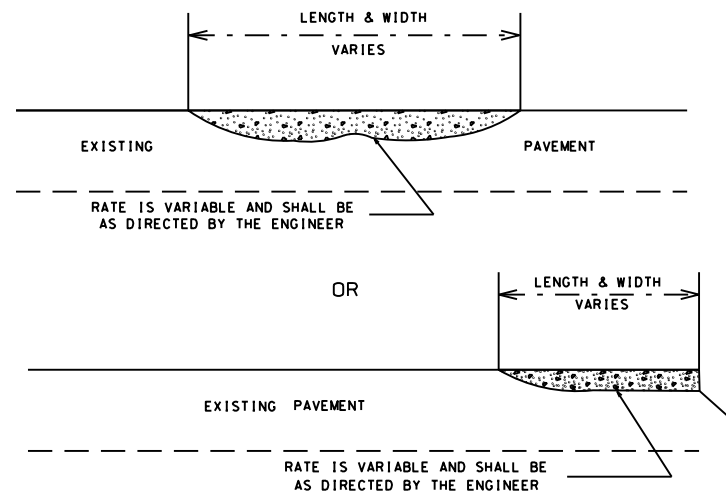

ASPHALT CONCRETE SURFACE COURSE
TYPE SF9.5A, S9.5B, and S9.5C. (LEVELING COURSE)

PROJ. REFERENCE NO.	SHEET NO.	TOTAL SHEETS
CLEVELAND CO. 2017-2018	4	
STATE PROJ. NO.	F. A. PROJ. NO.	DESCRIPTION
2017CPT. 12.18.10231		
2017CPT. 12.18.20231		

INCIDENTAL MILLING DETAILS

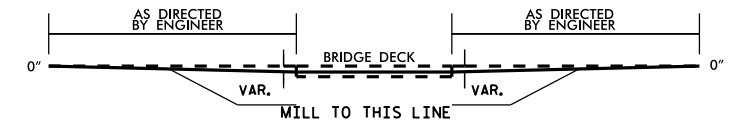

BRIDGE PROFILE

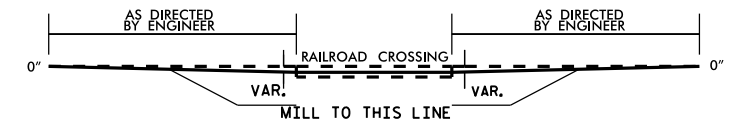

RAILROAD PROFILE

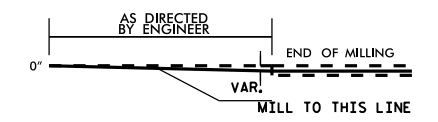

END OF MILLING PROFILE

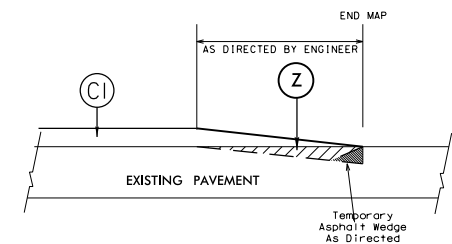

TIE-IN MILLING DETAIL

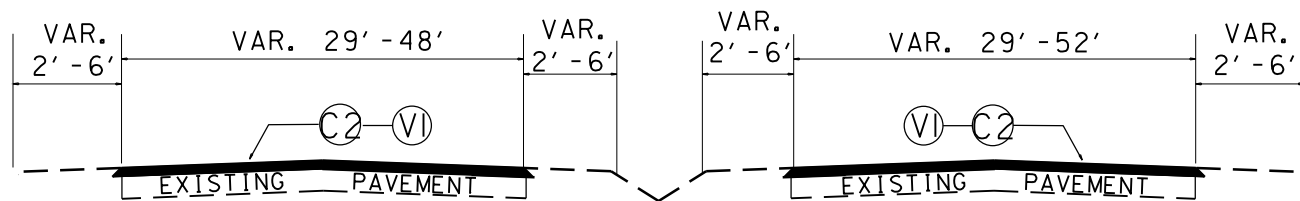

TYPICAL SECTION NO. 1

(MAP 1)

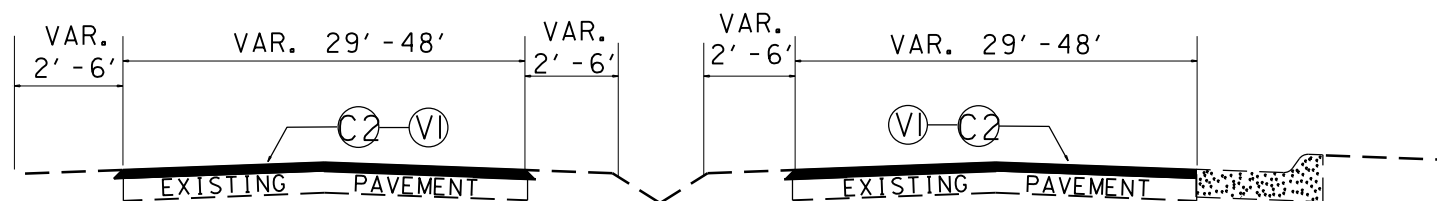

TYPICAL SECTION NO. 2

(MAP 1)

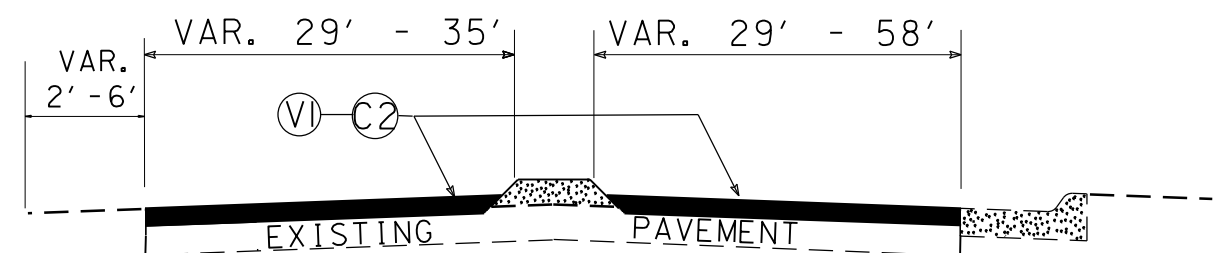

TYPICAL SECTION NO. 3

(MAP 1)

PROJ. REFERENCE NO.	SHEET NO.	TOTAL SHEETS
CLEVELAND CO. 2017-2018	5	
STATE PROJ. NO.	F. A. PROJ. NO.	DESCRIPTION
2017CPT.12.18.18231		
2017CPT.12.18.20231		

PAVEMENT SCHEDULE	
Y	SHOULDER RECONSTRUCTION (ASB)
C1	PROP. APPROX. 1½" ASPHALT CONCRETE SURFACE COURSE, TYPE S9.5B, AT AN AVERAGE RATE OF 168 LBS. PER SQ. YD.
C2	PROP. APPROX. 1½" ASPHALT CONCRETE SURFACE COURSE, TYPE S9.5C, AT AN AVERAGE RATE OF 168 LBS. PER SQ. YD.
C3	PROP. APPROX. 1" ASPHALT CONCRETE SURFACE COURSE, TYPE SF9.5A, AT AN AVERAGE RATE OF 110 LBS. PER SQ. YD.
E1	PROP. APPROX. 5.5" ASPHALT CONCRETE BASE COURSE, TYPE B25.0B, AT AN AVERAGE RATE OF 627 LBS. PER SQ. YD.
V1	MILL ASPHALT PAVEMENT APPROX. 1½" AS DIRECTED BY THE ENGINEER.
Z	INCIDENTAL MILLING AS DIRECTED BY THE ENGINEER.

NOTE: PAVEMENT EDGE SLOPES ARE 1:1 UNLESS SHOWN OTHERWISE.
MILL BRIDGE APPROACHES 100' TO PROVIDE A SMOOTH TRANSITION AS DIRECTED.
MILL INTO GUTTER LINE WHERE SHOWN AND AS DIRECTED.
MAINTAIN PROPER CROWN FOR DRAINAGE OF THE ROAD SURFACE.

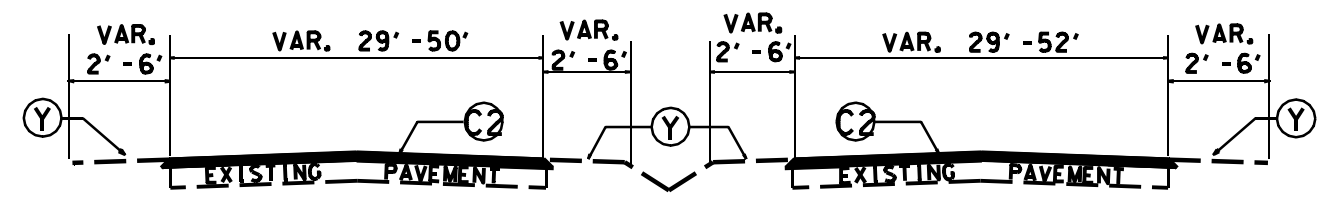

TYPICAL SECTION NO. 6
(MAP 1)

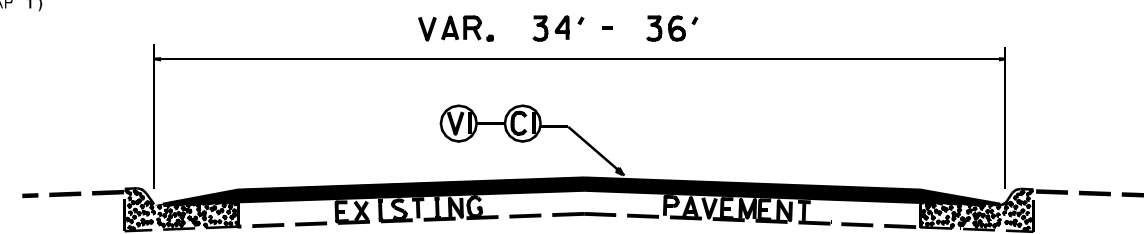

TYPICAL SECTION NO. 7
(MAP 2)

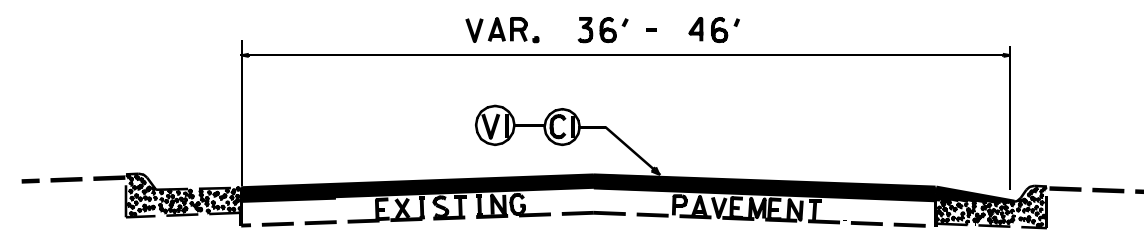

TYPICAL SECTION NO. 8
(MAP 3)

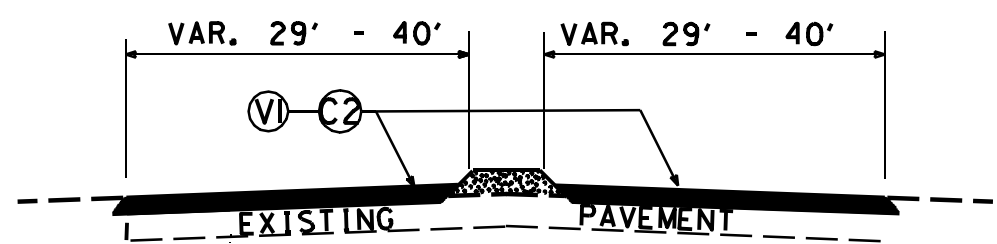

TYPICAL SECTION NO. 4
(MAP 1)

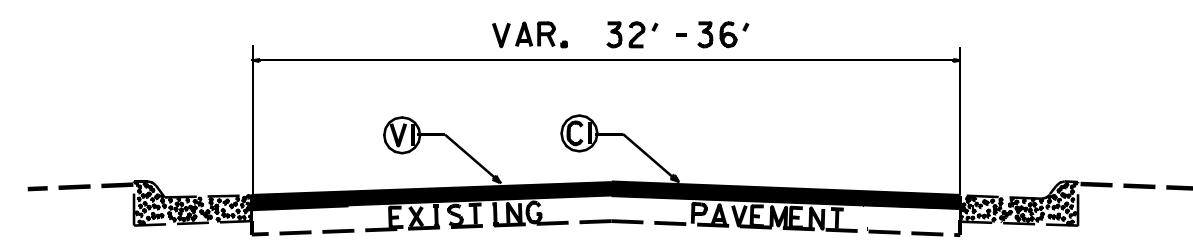

TYPICAL SECTION NO. 9
(MAP 3)

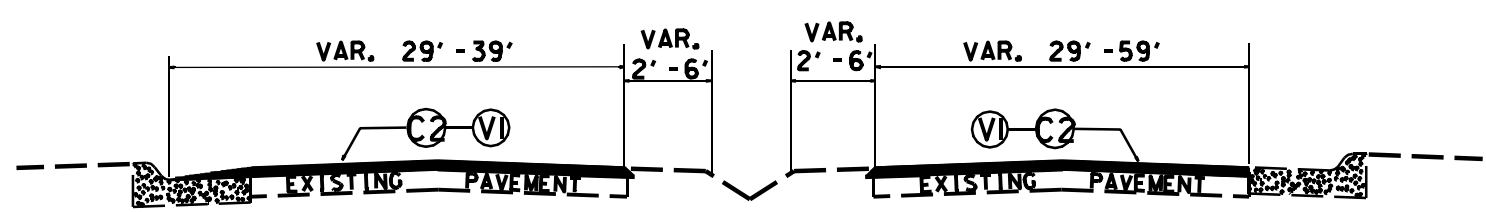

TYPICAL SECTION NO. 5
(MAP 1)

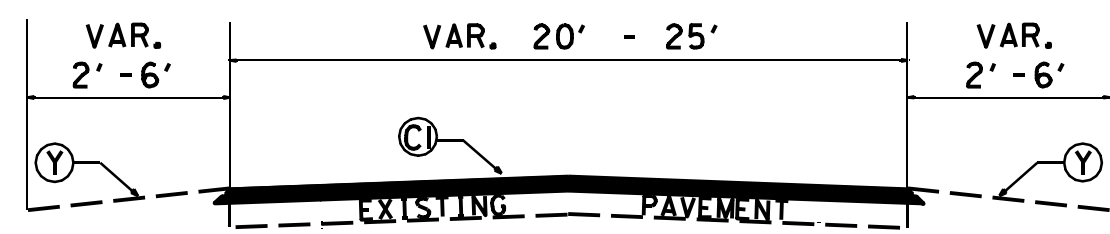

TYPICAL SECTION NO. 10
(MAP 3, 11)

PROJ. REFERENCE NO.	SHEET NO.	TOTAL SHEETS
CLEVELAND CO. 2017-2018	6	
STATE PROJ. NO.	F. A. PROJ. NO.	DESCRIPTION
2017CPT.12.18.10231		
2017CPT.12.18.20231		

PAVEMENT SCHEDULE	
Y	SHOULDER RECONSTRUCTION (ASB)
C1	PROP. APPROX. 1½" ASPHALT CONCRETE SURFACE COURSE, TYPE S9.5B, AT AN AVERAGE RATE OF 168 LBS. PER SQ. YD.
C2	PROP. APPROX. 1½" ASPHALT CONCRETE SURFACE COURSE, TYPE S9.5C, AT AN AVERAGE RATE OF 168 LBS. PER SQ. YD.
C3	PROP. APPROX. 1" ASPHALT CONCRETE SURFACE COURSE, TYPE SF9.5A, AT AN AVERAGE RATE OF 110 LBS. PER SQ. YD.
E1	PROP. APPROX. 5.5" ASPHALT CONCRETE BASE COURSE, TYPE B25.0B, AT AN AVERAGE RATE OF 627 LBS. PER SQ. YD.
V1	MILL ASPHALT PAVEMENT APPROX. 1½" AS DIRECTED BY THE ENGINEER.
Z	INCIDENTAL MILLING AS DIRECTED BY THE ENGINEER.

NOTE: PAVEMENT EDGE SLOPES ARE 1:1 UNLESS SHOWN OTHERWISE.
MILL BRIDGE APPROACHES 100' TO PROVIDE A SMOOTH TRANSITION AS DIRECTED.
MILL INTO GUTTER LINE WHERE SHOWN AND AS DIRECTED.
MAINTAIN PROPER CROWN FOR DRAINAGE OF THE ROAD SURFACE.

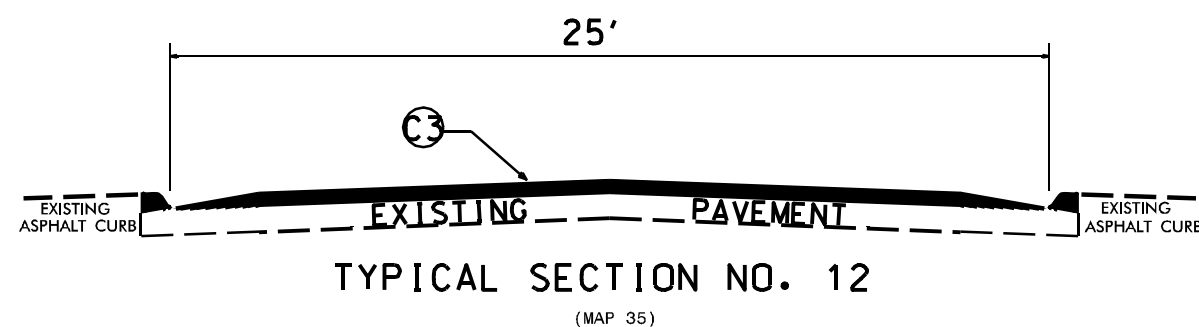
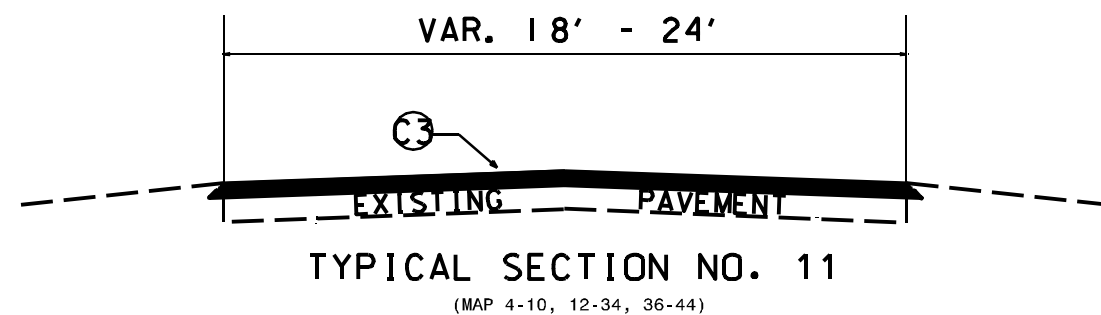
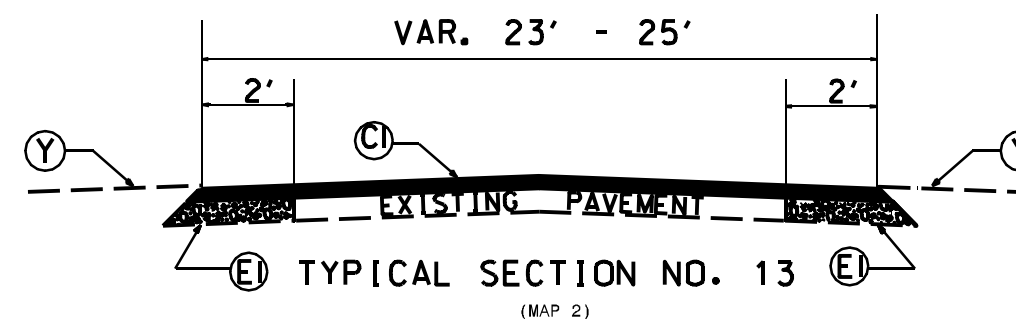

- NOTES:
- 1) DETAIL DOES NOT APPLY TO OGAFB AND ULTRA-THIN BONDED WEARING COURSE.
 - 2) BACKFILL SHOULDER WITH APPROVED MATERIAL.
 - 3) THE SHOULDER WEDGE DEVICE MAY BE DISENGAGED AT PAVED DRIVEWAYS, SIDE STREETS, HIGH SHOULDERS, AND OTHER LOCATIONS NOT FEASIBLE TO CONSTRUCT AS APPROVED BY THE ENGINEER.

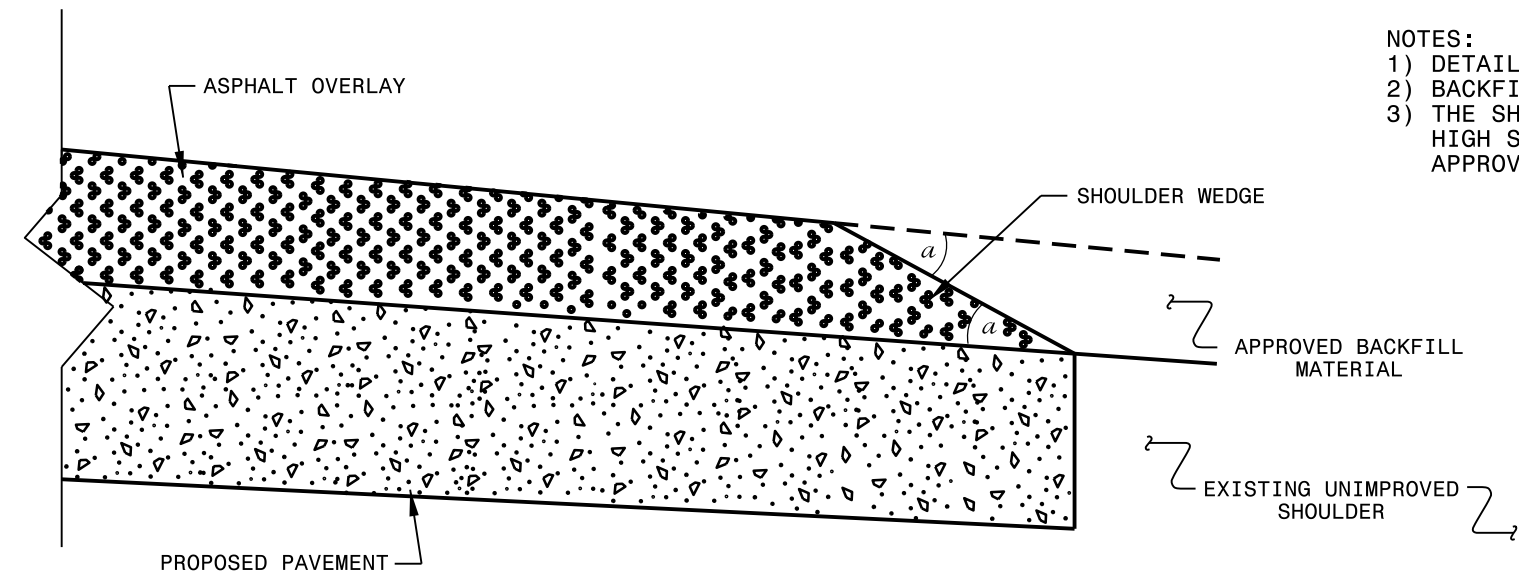

SHOULDER WEDGE DETAIL
(Resurfacing Projects w/ Widening or
with Existing Paved Shoulder having no dropoffs)

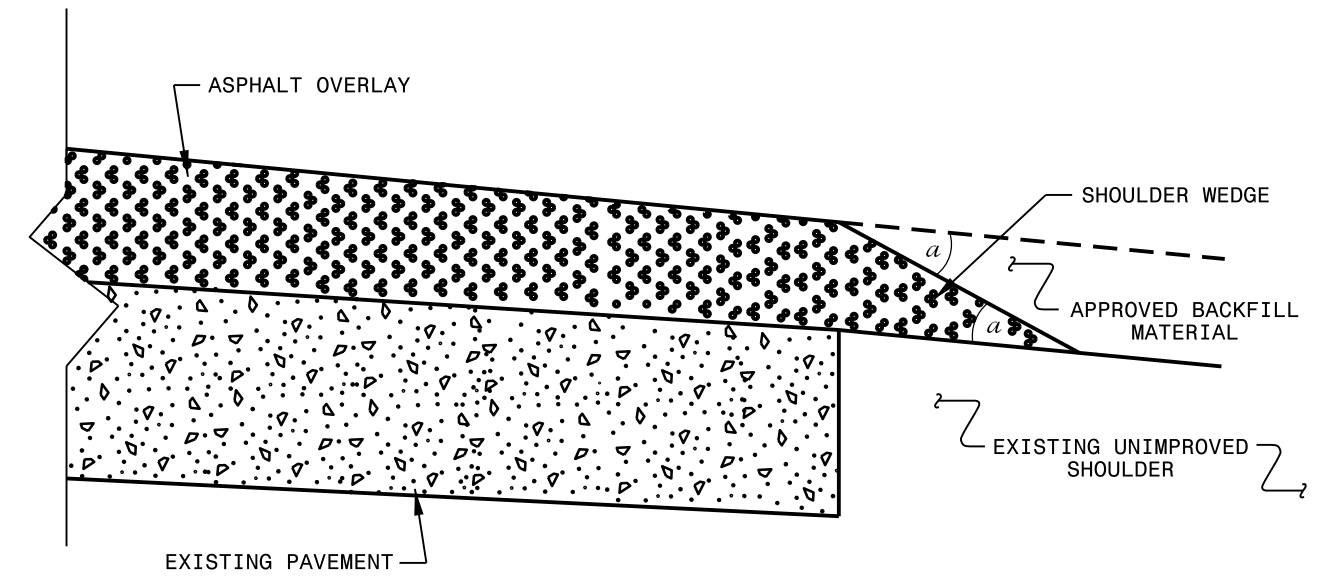

SHOULDER WEDGE DETAIL
(Resurfacing Projects w/ NO Widening)

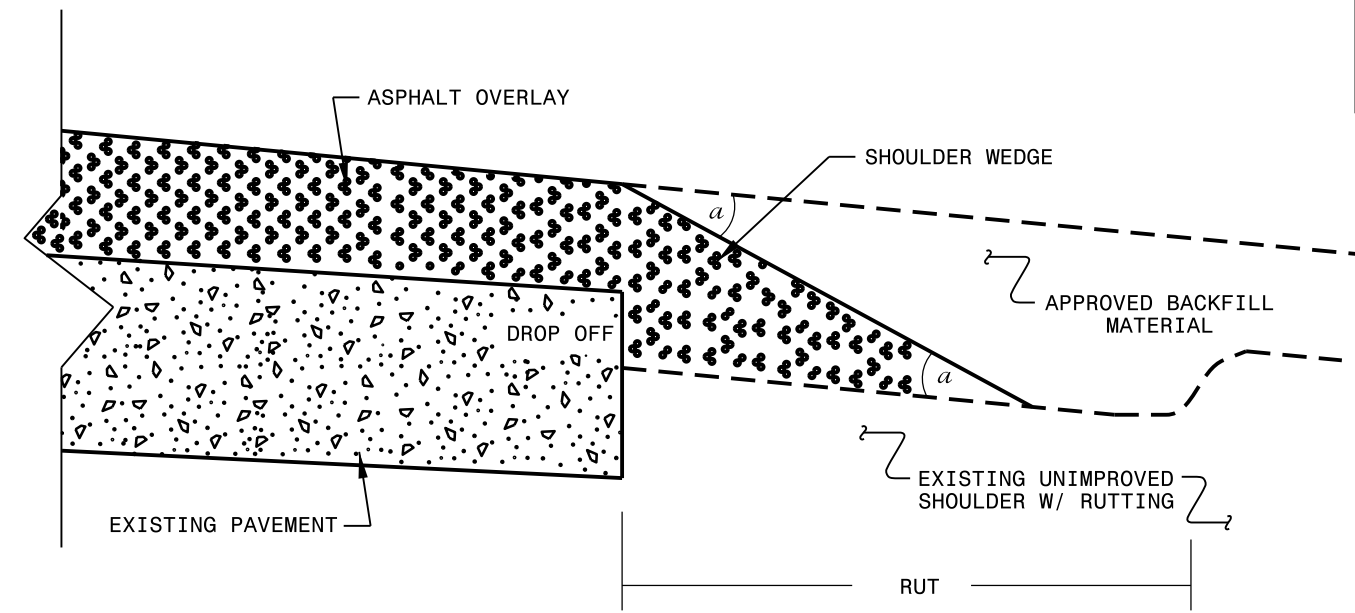

SHOULDER WEDGE DETAIL
(Resurfacing Adjacent to
Rutted Shoulder)

- SHOULDER WEDGE ANGLE = 30°

CONTRACT STANDARDS AND DEVELOPMENT UNIT	
Office 919-707-6950	FAX 919-250-4119
SHOULDER WEDGE DETAILS	
ORIGINAL BY: T.SPELL	DATE: 7-19-11
MODIFIED BY:	DATE: 2/2/16
CHECKED BY:	DATE:
FILE SPEC.: susr/details/stand/shoulderwedgedetail.dgn	

08-MAR-2017 07:42 S:\Contracts\Resurfacing Projects\Shoulder Wedge Details\Revised Shoulder Wedge Detail.dgn \$\$\$USERNAME\$\$\$

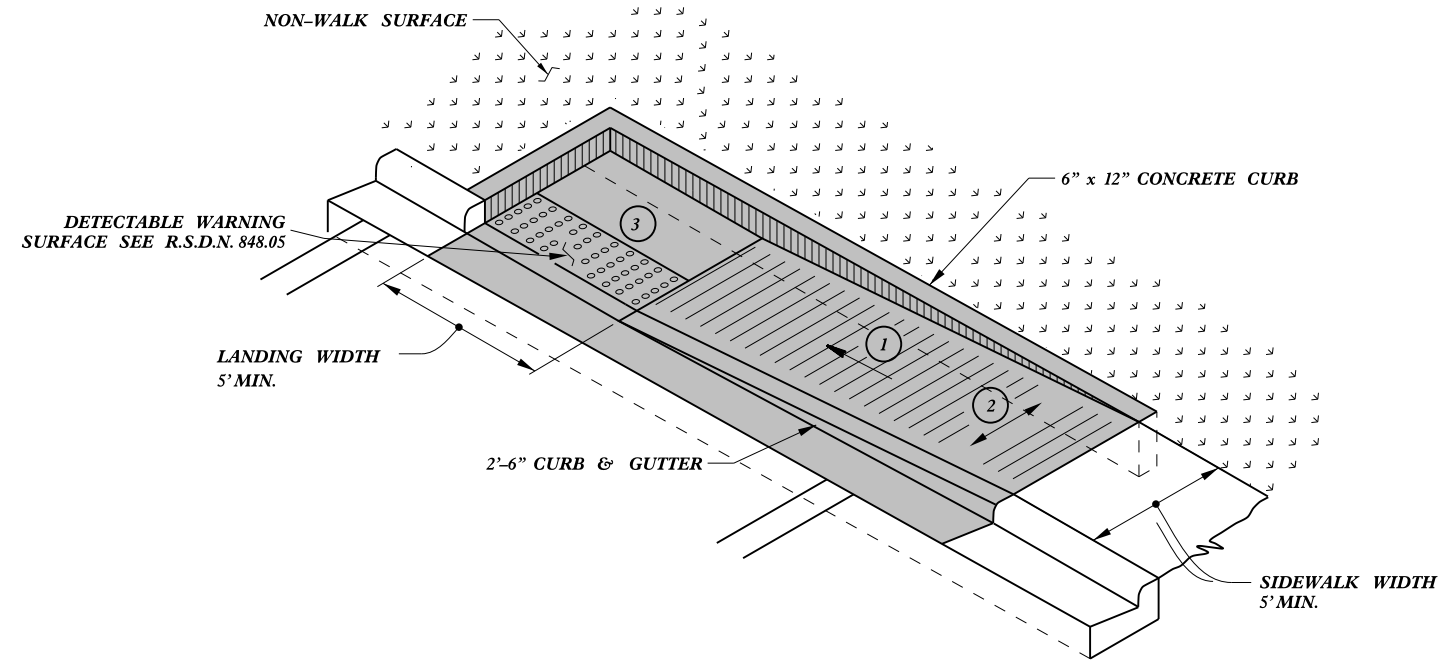

TYPE 1A

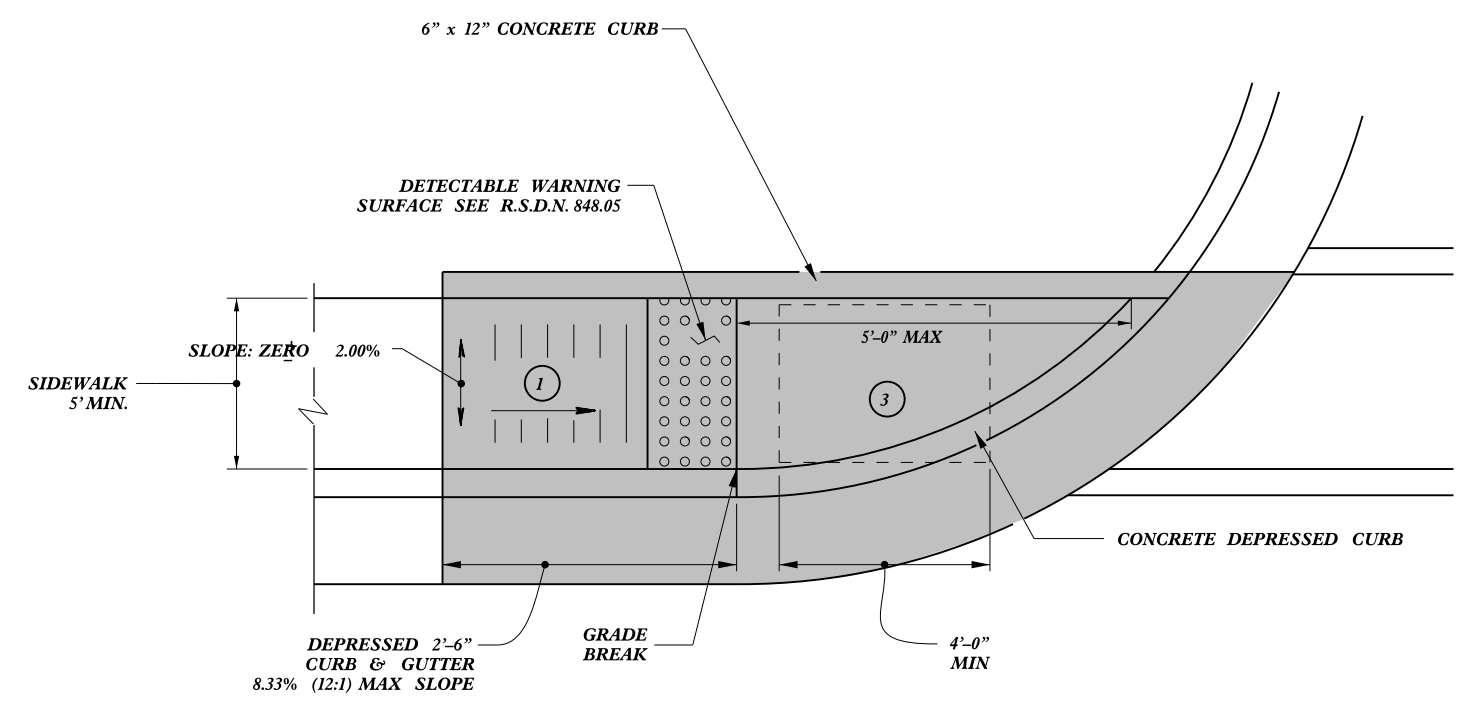

TYPE 1

- ① 8.33% (12:1) MAX RAMP SLOPE
- ② CROSS SLOPE: 2.00%
- ③ CURB RAMPS REQUIRE A (4'-0") MINIMUM LANDING WITH A MAXIMUM CROSS SLOPE AND LONGITUDINAL SLOPE OF 2.00% WHERE PEDESTRIANS PERFORM TURNING MANEUVERS. SLOPE TO DRAIN TO CURB.

PAY LIMITS FOR CURB RAMP

CONTRACT STANDARDS AND DEVELOPMENT UNIT	
Office 919-707-6950	FAX 919-250-4119
CURB RAMPS	
Directional Ramps	
ORIGINAL BY: J.S. HOWERTON	DATE: 7/7/11
MODIFIED BY:	DATE:
CHECKED BY:	DATE:
FILE SPEC: sstds/2012CurbRamp/CurbRampDetails.dwg	

REFER TO ROADWAY STANDARD DRAWING NUMBER 848.05 SHEET 3 OF 3 FOR ALL RAMP NOTES

23-MAR-2012 15:05 J:\Contracts\2012\Standard Drawings\2012 Standard Drawings\Curb Ramp Special Details\Curb Ramp Details.dwg J.Howerton AT 15023750

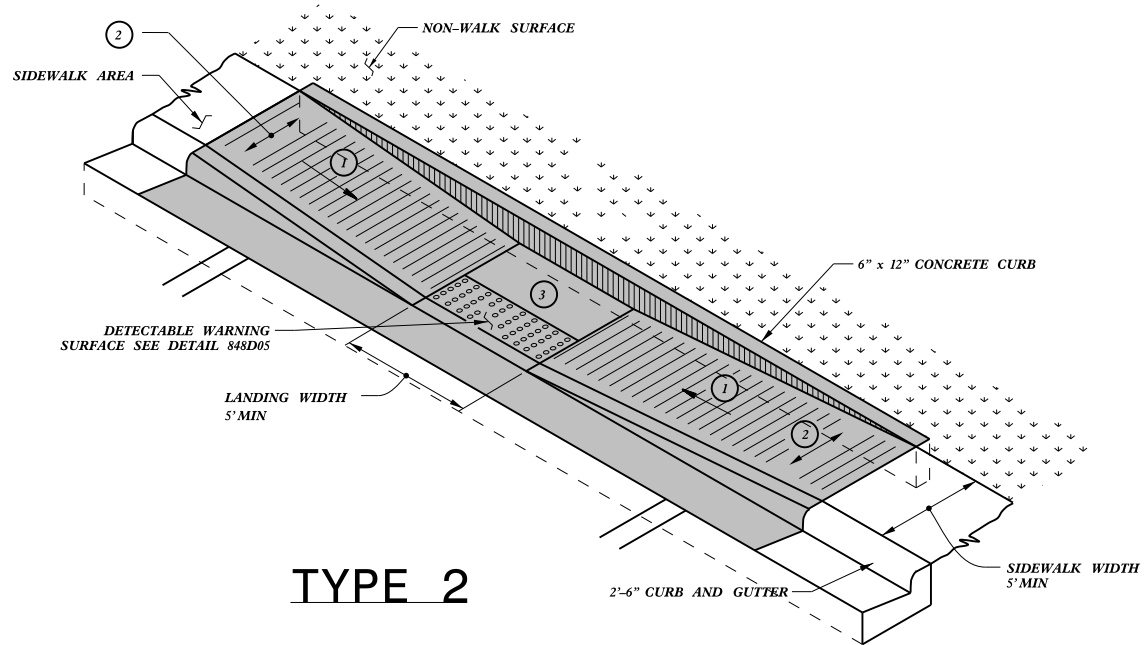

TYPE 2

PAY LIMITS FOR CURB RAMP

- 1 8.33% (12:1) MAX RAMP SLOPE
- 2 CROSS SLOPE: 2.00%
- 3 CURB RAMPS REQUIRE A (4'-0") MINIMUM LANDING WITH A MAXIMUM CROSS SLOPE AND LONGITUDINAL SLOPE OF 2.00% WHERE PEDESTRIANS PERFORM TURNING MANEUVERS. SLOPE TO DRAIN TO CURB.

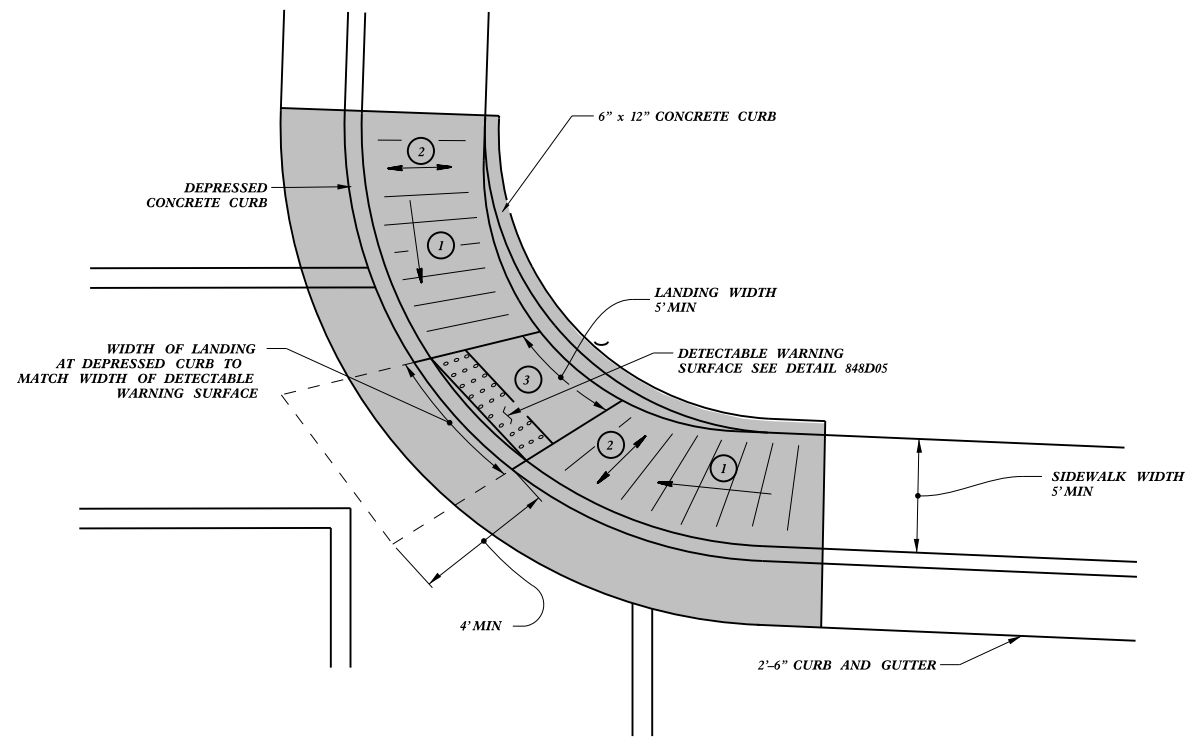

TYPE 2A

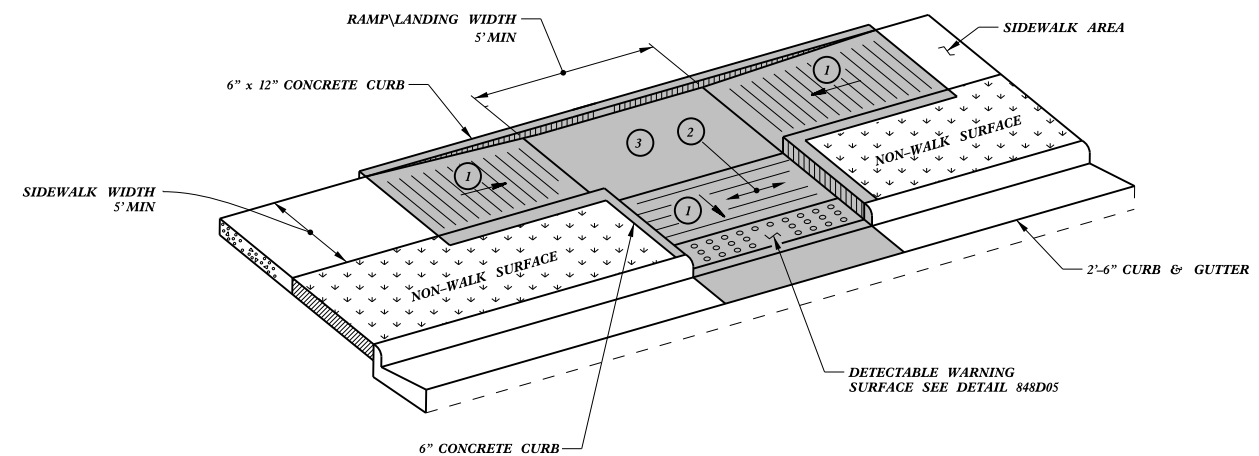

TYPE 3

CONTRACT STANDARDS AND DEVELOPMENT UNIT	
Office 919-707-6950	FAX 919-250-4119
CURB RAMPS	
Parallel Ramps	
ORIGINAL BY: J.S. HOWERTON	DATE: 7/7/11
MODIFIED BY:	DATE:
CHECKED BY:	DATE:
FILE SPEC: sstds/2012CurbRamp/CurbRampDetails.dwg	

REFER TO ROADWAY STANDARD DRAWING NUMBER 848.05 SHEET 3 OF 3 FOR ALL RAMP NOTES

23-MAR-2012 15:07 C:\Contracts\Special Details\Howerton\Standard Drawings\2012 Standard Drawings\Curb Ramp Details\Curb Ramp Details.dwg

5/14/99

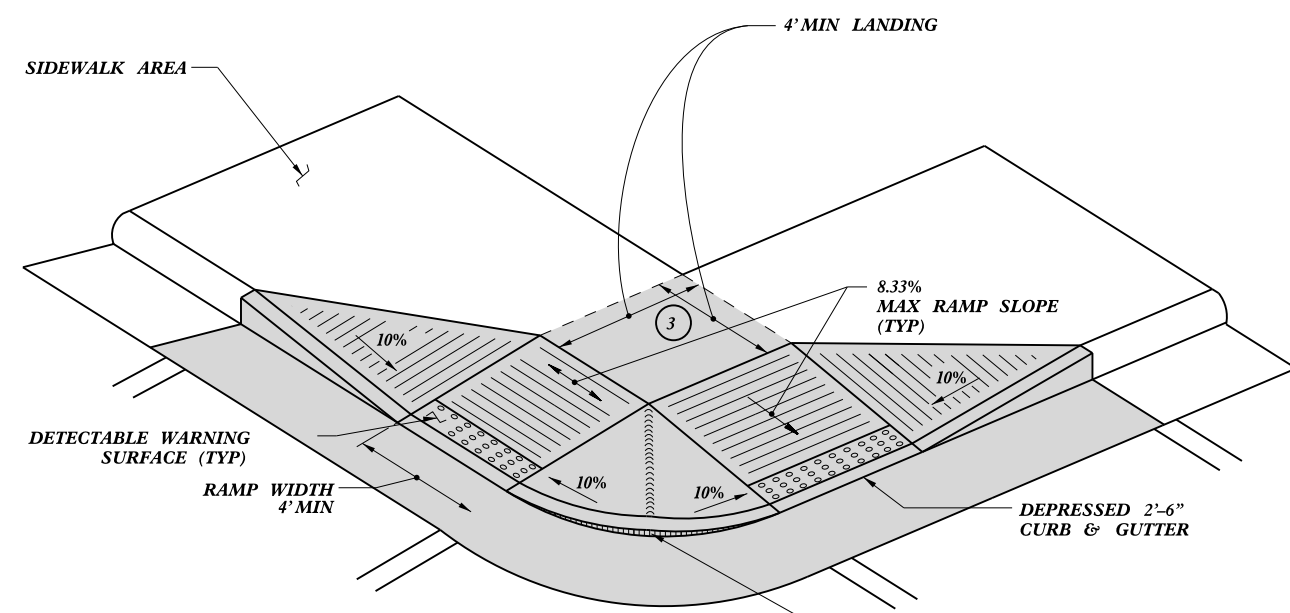

TYPE 4



TYPE 5

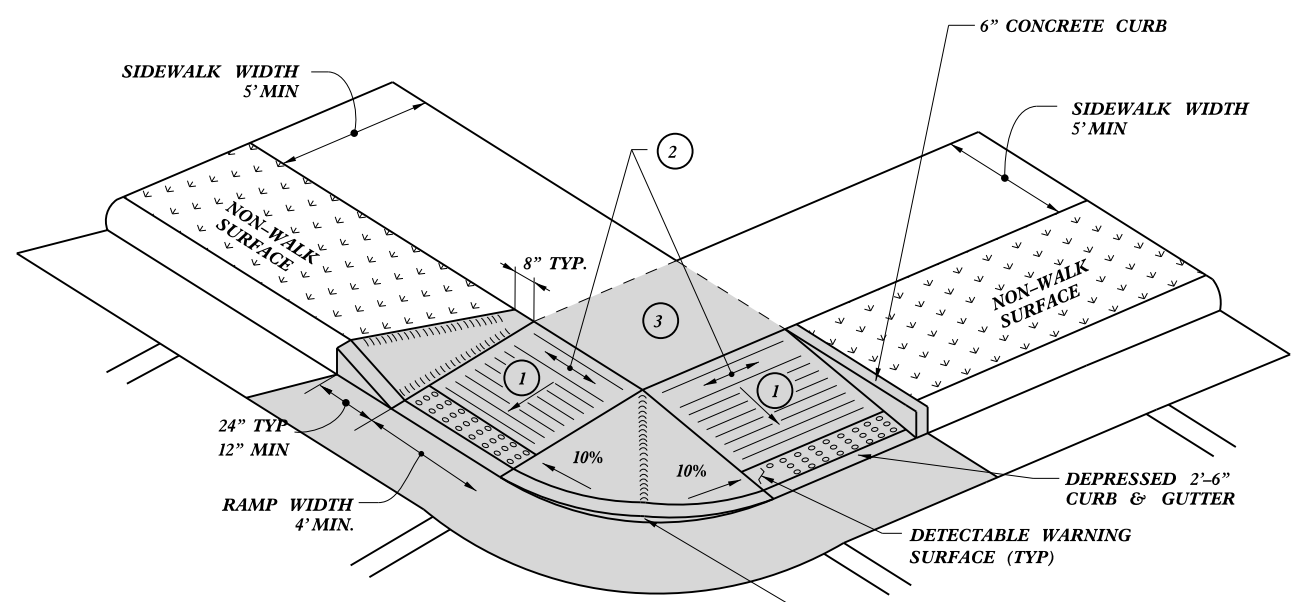

TYPE 4A

- 1 8.33% (12:1) MAX RAMP SLOPE
- 2 CROSS SLOPE: 2.00%
- 3 CURB RAMPS REQUIRE A (4'-0") MINIMUM LANDING WITH A MAXIMUM CROSS SLOPE AND LONGITUDINAL SLOPE OF 2.00% WHERE PEDESTRIANS PERFORM TURNING MANEUVERS. SLOPE TO DRAIN TO CURB.

CONTRACT STANDARDS AND DEVELOPMENT UNIT	
Office 919-707-6950	FAX 919-250-4119
CURB RAMPS	
Shared Landing	
ORIGINAL BY: J.S. HOWERTON	DATE: 7/7/11
MODIFIED BY:	DATE:
CHECKED BY:	DATE:
FILE SPEC: stds/2012CurbRamp/CurbRampDetails.dwg	

REFER TO ROADWAY STANDARD DRAWING NUMBER 848.05 SHEET 3 OF 3 FOR ALL RAMP NOTES

23-MAR-2012 15:08 C:\Users\jhowerton\Documents\Standard Drawings\2012 Standard Drawings\Curb Ramp Special Details\Curb Ramp Details.dwg jhowerton AT 05023750

SIGNING FOR RESURFACING PROJECTS

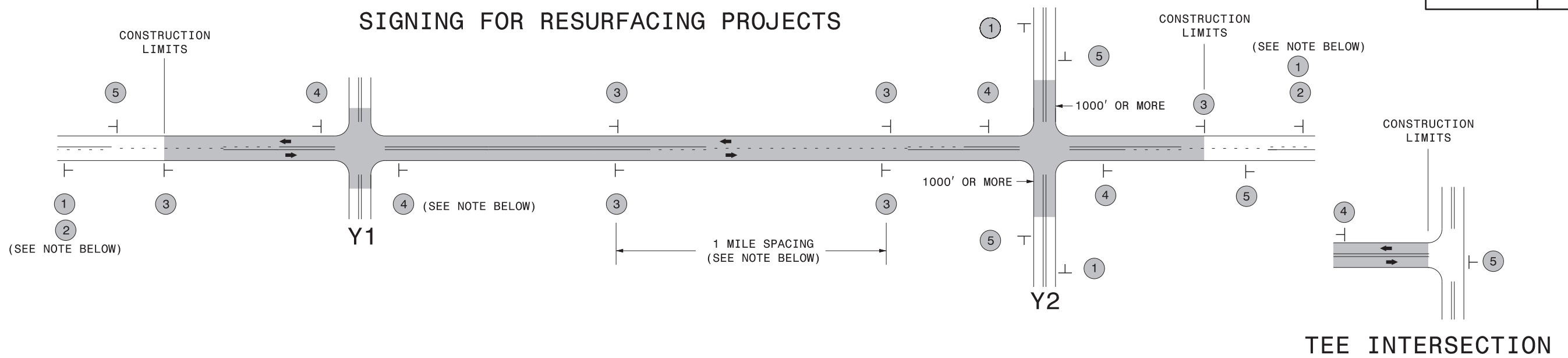

LEGEND	
⊥	STATIONARY SIGN
←	DIRECTION OF TRAFFIC FLOW

MAINLINE (-L-) SIGNING

-Y- LINE SIGNING

SIGNING NOTES AND PLACEMENT PER DIRECTION	MAINLINE (-L-) SIGNING		-Y- LINE SIGNING	
	1	 W20-1 48" X 48"	<p>PLACE 1000' PRIOR TO BEGINNING OF CONSTRUCTION LIMITS. ONLY USED ON -Y- LINES IF RESURFACING LIMITS EXTEND 1000' ALONG -Y- LINE.</p>	<p>NO REQUIRED STATIONARY SIGNING FOR THE FOLLOWING -Y- LINE CONDITIONS:</p> <ol style="list-style-type: none"> 1) LESS THAN 1000' OF RESURFACING ALONG -Y- LINE 2) SUBDIVISION ROADS 3) DEAD END ROADS <p>WHEN PAVING/CONSTRUCTION ACTIVITIES PROCEED ACROSS AN UNSIGNED -Y- LINE, ADVANCE WARNING PORTABLE SIGNS SHALL BE USED ALONG THE -Y- LINE AS SHOWN BELOW. REMOVE UPON COMPLETION OF WORK.</p> <div style="display: flex; justify-content: space-around;"> <div style="text-align: center;"> <p>W20-1 48" X 48"</p> </div> <div style="text-align: center;"> <p>W20-7 A 48" X 48"</p> </div> </div> <p>PLACED 500' IN ADVANCE OF FLAGGER. PLACED 250' IN ADVANCE OF FLAGGER.</p>
	2	 W7-3aP 24" X 18"	<p>#2 SIGN ONLY USED WHEN RESURFACING LIMITS ARE 2 OR MORE MILES IN LENGTH. ROUND UP TO NEXT WHOLE NUMBER. (NO FRACTIONAL OR DECIMAL NUMBERS)</p>	
	3	 SP 13107 48" X 48"	<ul style="list-style-type: none"> - PLACE INITIALLY AT THE CONSTRUCTION LIMITS AND SPACE 1 MILE APART THEREAFTER. - AT TEE INTERSECTIONS INSTALL INITIALLY 0.5 MILE FROM INTERSECTION AND SPACE 1 MILE APART THEREAFTER. 	
	4	 SP 13106 48" X 48"	<ul style="list-style-type: none"> - THESE ARE FOR -Y- LINES THAT ARE "THROUGH" ROADWAYS. DEAD END AND SUBDIVISION ROADS ARE NOT "THROUGH" ROADWAYS. - INSTALL 500' +/- FROM EACH -Y- LINE APPROACH AS SHOWN ABOVE. - FOR MULTIPLE -Y- LINES THAT ARE SEPARATED BY 0.25 MILES OR LESS, TREAT AS A SINGLE UNIT AND INSTALL WITHIN 500' OF EACH APPROACH. - A MAXIMUM OF 2 SIGN SETS PER MILE. DO NOT INSTALL WHEN -Y- LINES ARE WITHIN 0.5 MILES FROM "END ROAD WORK" SIGN. - FOR TEE INTERSECTIONS, INSTALL WITHIN 500' +/- OF THE INTERSECTION ALONG -L- LINE. 	
5	 G20-2 A 48" X 24"	<p>PLACE 500' FOLLOWING THE END OF CONSTRUCTION LIMITS OR AS SHOWN WHEN WORK ENDS AT A 3-WAY TEE INTERSECTION.</p>		

4/20/2016 C:\Users\rmgarrrett\Desktop\Resurfacing_AdvWarn_2Ln.dgn User:rmgarrrett

**RESURFACING
ADVANCE WARNING SIGNS
FOR
RURAL AND SUBURBAN
2 LANE ROADWAYS**

URBAN / SUBURBAN WORKZONES

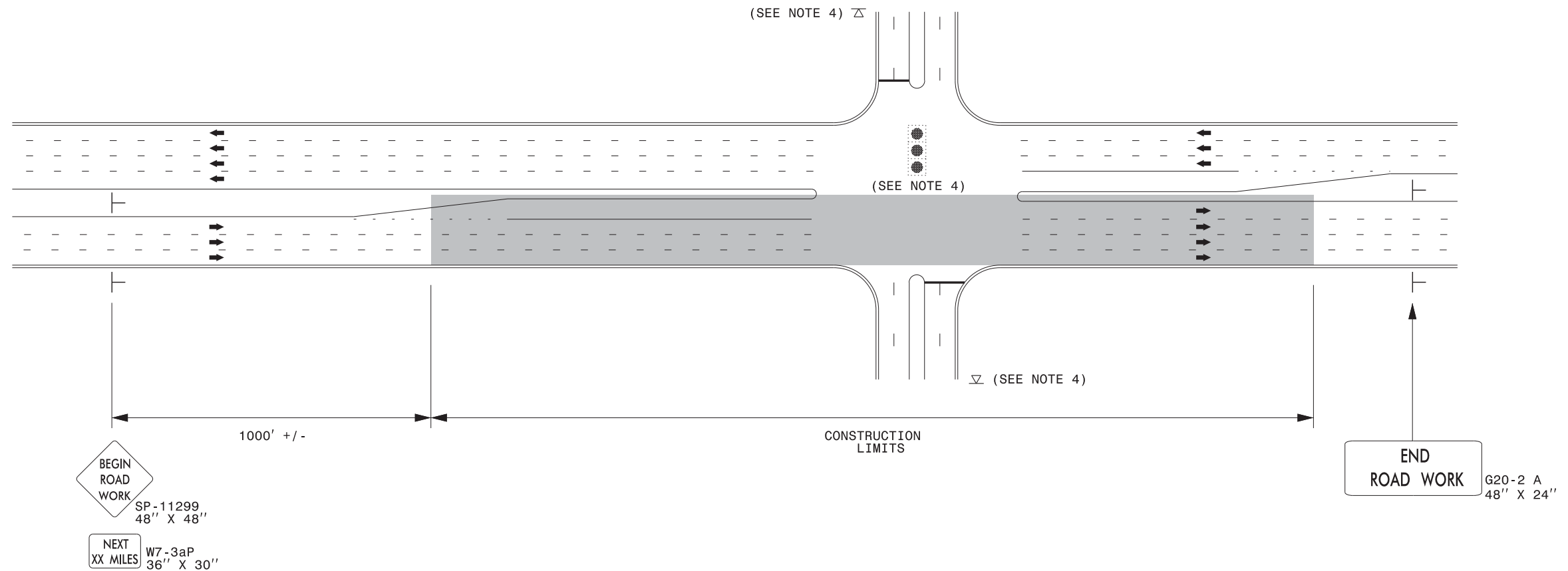

NOTES:

- 1) 48" x 48" SIZED SIGNS (SP- 11299) MAY BE REDUCED TO 36" X 36" ON ROADWAYS WITH SPEED LIMITS OF 40 MPH OR LESS.
- 2) MOUNT SIGNS THAT ARE LARGER THAN 10 SQUARE FEET IN AREA ON TWO OR MORE WOOD OR U-CHANNEL SUPPORTS. PERFORATED SQUARE TUBING SUPPORT SYSTEMS MAY SUPPORT LARGER AREAS ON A SINGLE SUPPORT. FOLLOW MANUFACTURER'S RECOMMENDATIONS. THESE SYSTEMS SHALL BE NCHRP 350 COMPLIANT AND NCDOT APPROVED.
- 3) ADVANCE WARNING SIGNS NOT REQUIRED ON NON-SIGNALIZED SIDE STREETS.
- 4) MAY USE LAW ENFORCEMENT TO CONTROL TRAFFIC AT SIGNALIZED INTERSECTIONS AS DIRECTED BY THE ENGINEER. PROVIDE PORTABLE "ROAD WORK AHEAD" (W20-1) SIGNS 500' IN ADVANCE ALONG BOTH APPROACHES FROM THE SIDE STREETS WHEN PAVING PROCEEDS THROUGH THE INTERSECTION.
- 5) LATERAL CLEARANCE AT ALL SIGN LOCATIONS SHALL BE 2' AS MEASURED FROM THE EDGE OF PAVEMENT OR THE FACE OF THE CURB. WHEN UNABLE TO OBTAIN THE LATERAL CLEARANCE WITHIN THE MEDIAN AREA USE SHOULDER MOUNTS ONLY.
- 6) SIGN MOUNT LOCATIONS SHALL NOT BLOCK SIDEWALKS OR DRIVEWAYS.
- 7) IF STATIONARY GENERAL WARNING SIGNS ARE USED, THEY WILL BE PAID FOR PER SECTION 104 OF THE NCDOT STANDARD SPECIFICATIONS AS EXTRA WORK.
- 8) IF MILLED AREAS ARE NOT PAVED BACK BY THE END OF THE WORK DAY, PORTABLE SIGNS SHALL BE USED TO WARN DRIVERS OF THE PRESENT CONDITIONS. THESE ARE TO INCLUDE, BUT NOT LIMITED TO "ROUGH ROAD" W8-8, "UNEVEN LANES" W8-11, "GROOVED PAVEMENT" W8-15 w/MOTORCYCLE PLAQUE MOUNTED BELOW. THESE ARE TO BE DOUBLE INDICATED ON MULTI-LANE ROADWAYS WITH SPEED LIMITS 45 MPH AND GREATER WHERE LATERAL CLEARANCE CAN BE OBTAINED WITHIN THE MEDIAN AREAS. THESE PORTABLE SIGNS ARE INCIDENTAL TO THE OTHER ITEMS OF WORK INCLUDED IN THE TEMPORARY TRAFFIC CONTROL (LUMP SUM) PAY ITEM.

LEGEND

- ┆ STATIONARY SIGN
- ➔ DIRECTION OF TRAFFIC FLOW



**RESURFACING ADVANCE
WARNING SIGNS FOR
URBAN / SUBURBAN
FACILITIES**

DIVIDED MEDIANS WITH WIDTHS 46' OR GREATER

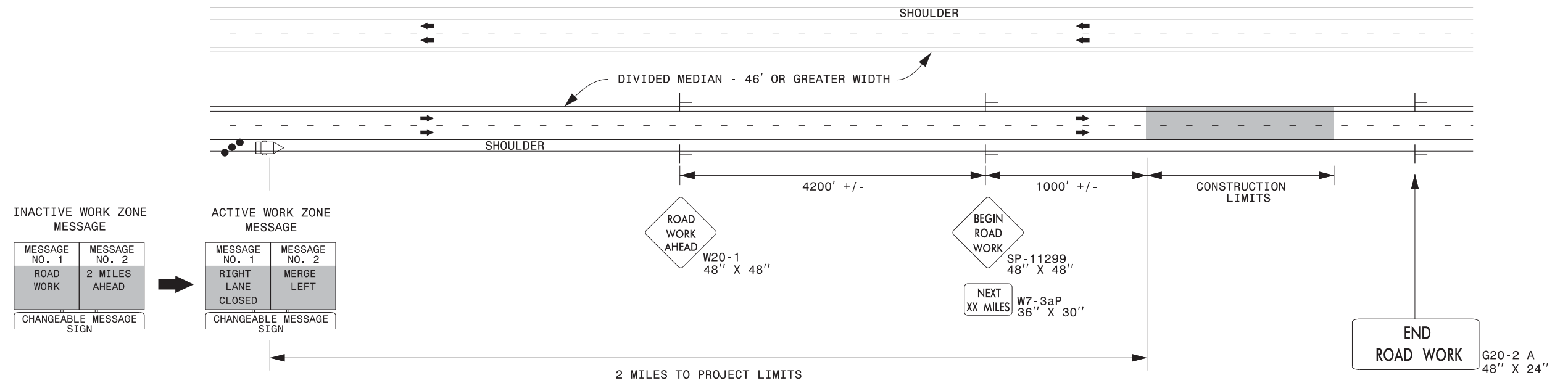

DIVIDED MEDIANS WITH WIDTHS LESS THAN 46' OR WITH PERMANENT MEDIAN BARRIER

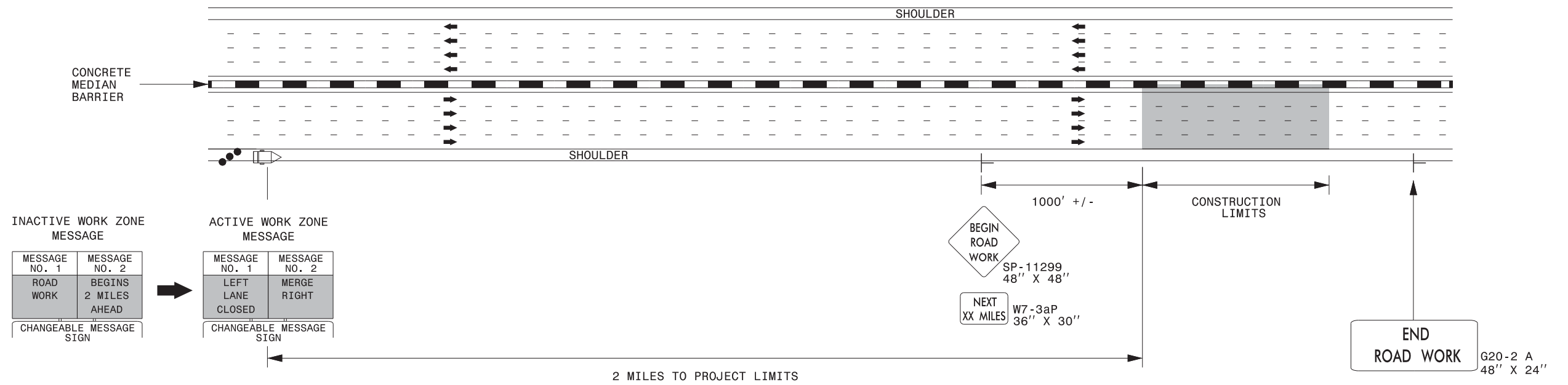

NOTES:

- 1) LATERAL CLEARANCE AT ALL SIGN LOCATIONS SHALL BE 6' AS MEASURED FROM THE EDGE OF PAVEMENT.
- 2) MOUNT SIGNS THAT ARE LARGER THAN 10 SQUARE FEET IN AREA ON TWO OR MORE WOOD OR U-CHANNEL SUPPORTS. PERFORATED SQUARE TUBING SUPPORT SYSTEMS MAY SUPPORT LARGER AREAS ON A SINGLE SUPPORT. FOLLOW MANUFACTURER'S RECOMMENDATIONS. THESE SYSTEMS SHALL BE NCHRP 350 COMPLIANT AND NCDOT APPROVED.
- 3) FOR MEDIAN WIDTHS LESS THAN 46' (MEASURED EDGELINE TO EDGELINE) USE THE BOTTOM DRAWING.
- 4) IF STATIONARY GENERAL WARNING SIGNS ARE USED, THEY WILL BE PAID FOR PER SECTION 104 OF THE NCDOT STANDARD SPECIFICATIONS AS EXTRA WORK.
- 5) INSTALL "ROAD WORK AHEAD" (W20-1) ALONG ENTRANCE RAMP 500' PRIOR TO RAMP TERMINAL, AND "END ROAD WORK" (G20-2a) AT THE END OF EXIT RAMP WITHIN THE WORK ZONE.
- 6) IF MILLED AREAS ARE NOT PAVED BACK BY THE END OF THE WORK DAY, PORTABLE SIGNS SHALL BE USED TO WARN DRIVERS OF THE PRESENT CONDITIONS. THESE ARE TO INCLUDE, BUT NOT LIMITED TO "ROUGH ROAD" W8-8, "UNEVEN LANES" W8-11, "GROOVED PAVEMENT" W8-15 w/MOTORCYCLE PLAQUE MOUNTED BELOW. THESE ARE TO BE DOUBLE INDICATED ON MULTI-LANE ROADWAYS WITH SPEED LIMITS 45 MPH AND GREATER AND WITH DIVIDED MEDIANS OF 46' OR GREATER. THESE PORTABLE SIGNS ARE INCIDENTAL TO THE OTHER ITEMS OF WORK INCLUDED IN THE TEMPORARY TRAFFIC CONTROL (LUMP SUM) PAY ITEM.

LEGEND

- CHANGEABLE MESSAGE SIGN (CMS)
- STATIONARY SIGN
- DIRECTION OF TRAFFIC FLOW
- TRAFFIC DRUM



**RESURFACING ADVANCE
WARNING SIGNS FOR
HIGH SPEED FACILITIES
≥ 60 MPH**

High Speed Detection (≥40 mph)

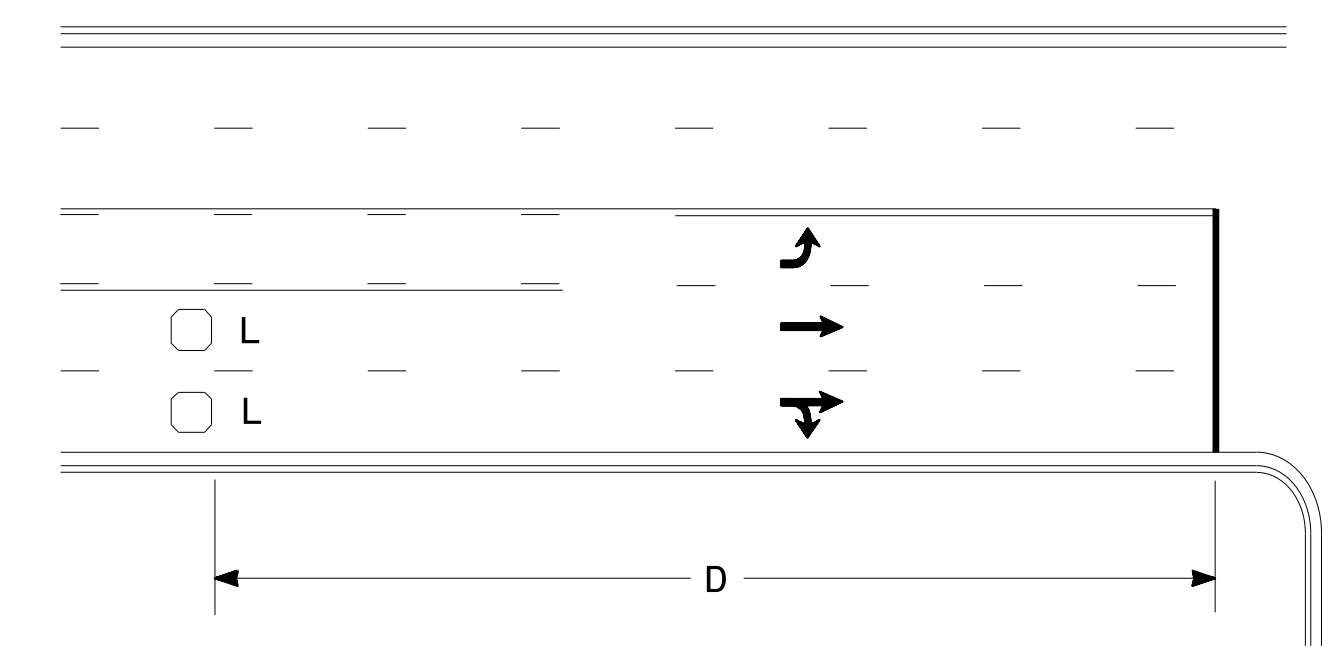

Speed Limit mph	D ft
40	250
45	300
50	355
55	420

L = 6ft X 6ft
Wired in series for TS1
Controllers
Wired separately for TS2,
170, and 2070L Controllers

Volume Density Operation

OR

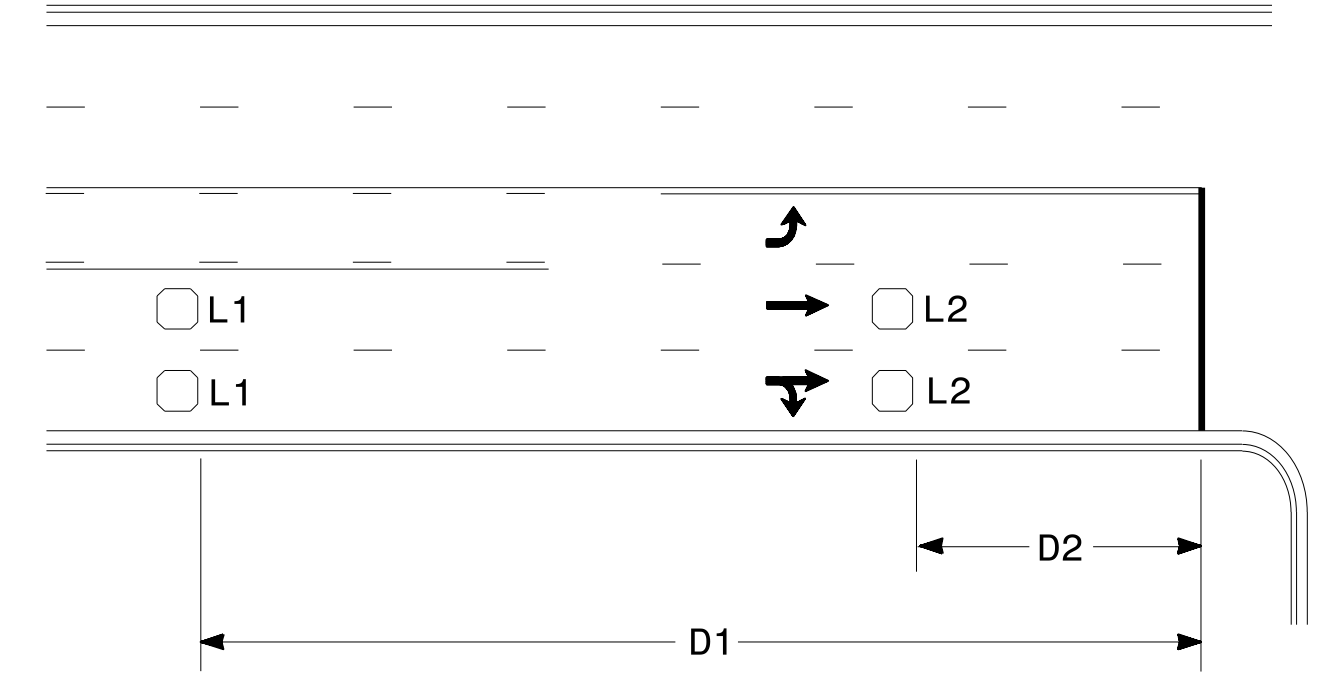

Speed Limit mph	D1 ft	D2 ft
40	250	80
45	300	90
50	355	100
55	420	110

L1 = 6ft X 6ft
Wired in series
L2 = 6ft X 6ft
Wired in series

"Stretch" Operation

Low Speed Detection (≤35 mph)

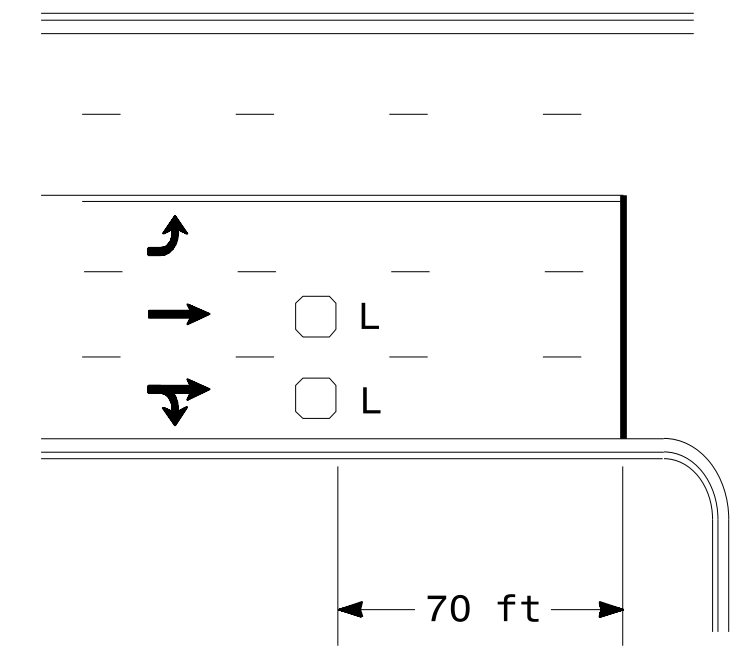

L = 6ft X 6ft
Wired in series

OR

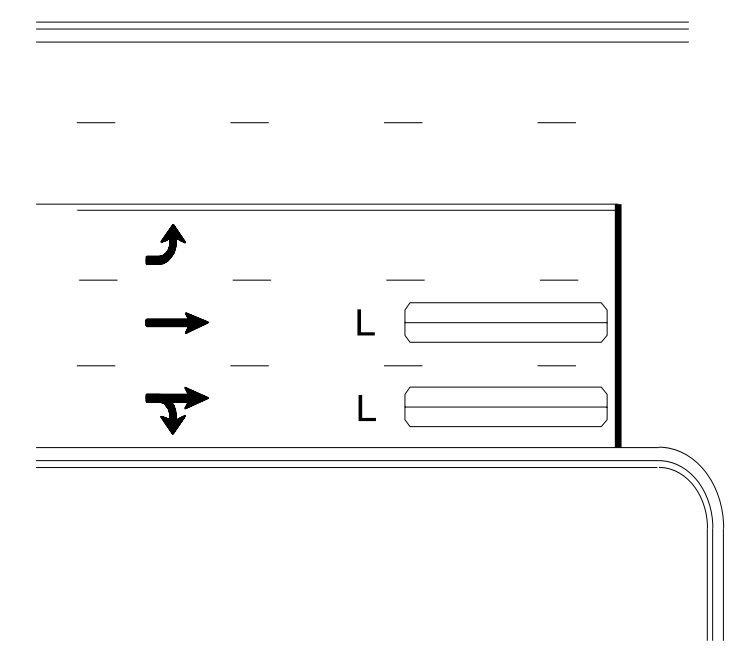

L = 6ft X 40ft
Quadrupole loop, wired separately

Left Turn Lane Detection

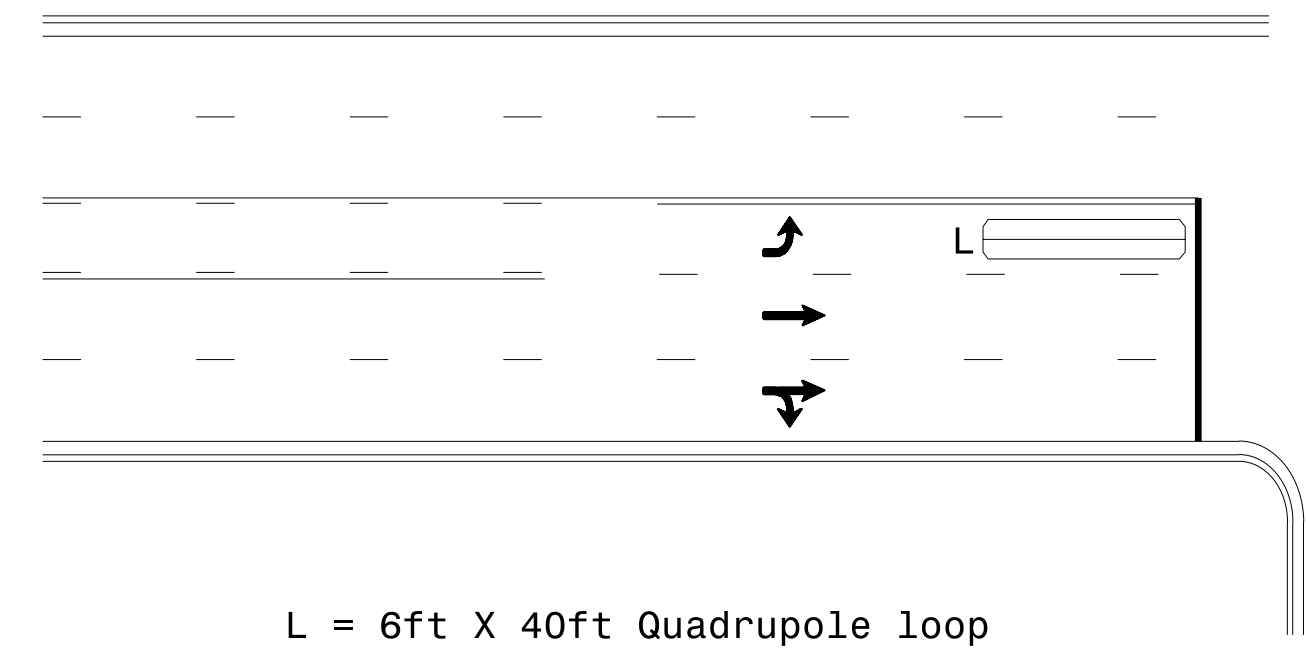

L = 6ft X 40ft Quadrupole loop

Presence Loop Detection

OR

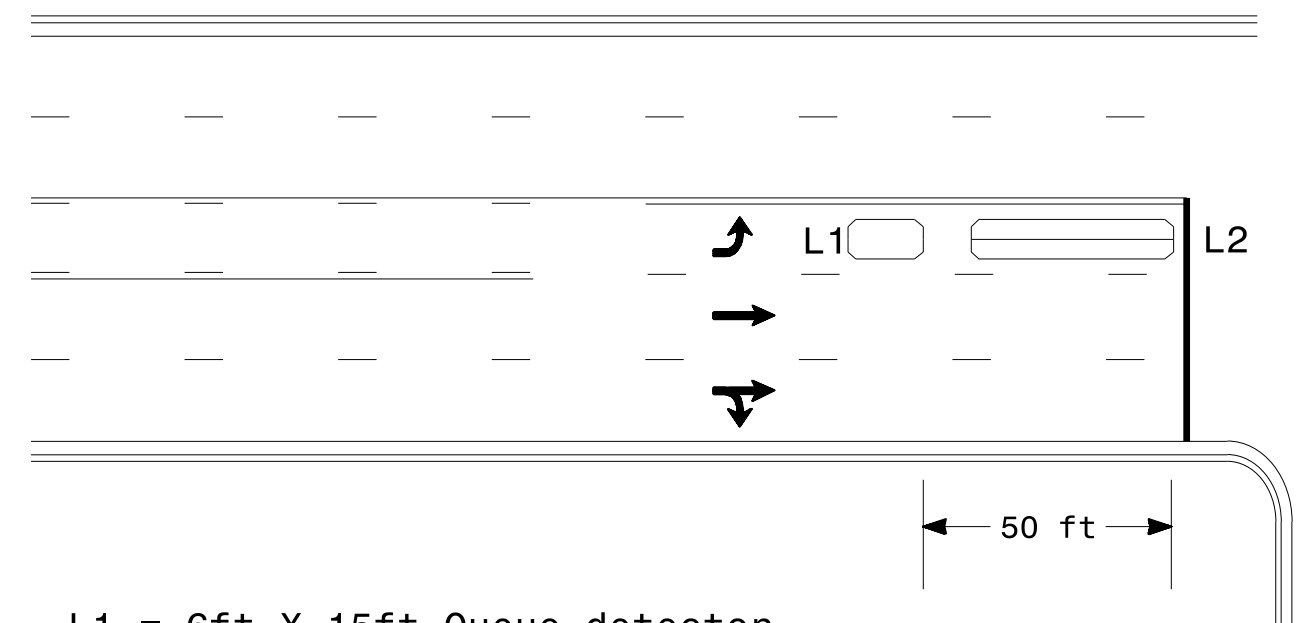

L1 = 6ft X 15ft Queue detector
L2 = 6ft X 40ft Quadrupole loop

Queue Loop Detection

Right Turn Lane Detection

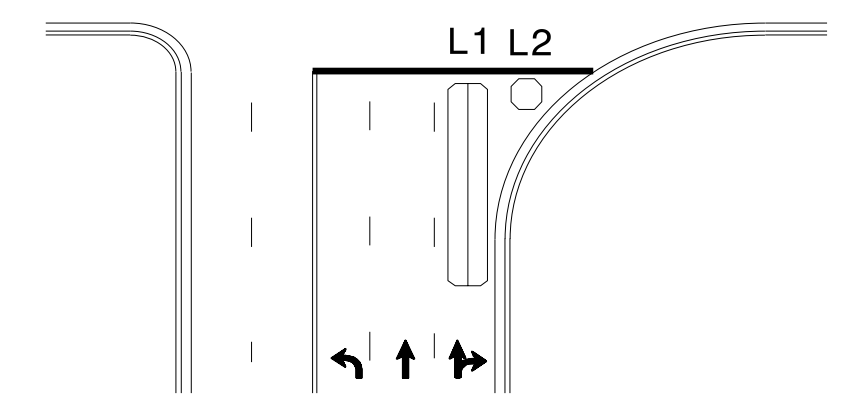

Shared Lane/
Wide Radius Turn

L1 = 6ft X 40ft Quadrupole loop
L2 = 6ft X 6ft [Minimum] Presence loop
Wired separately

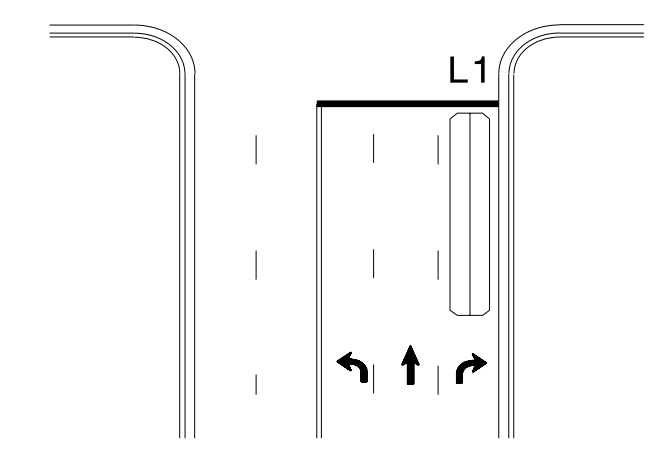

Standard Turn

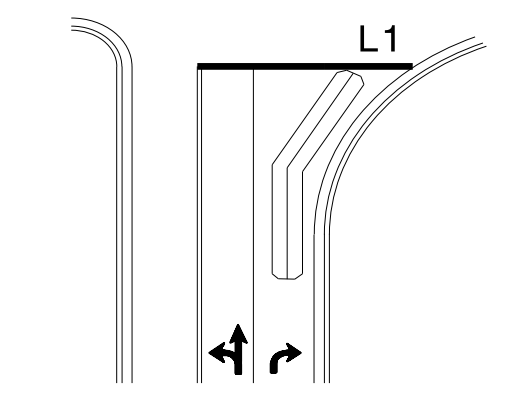

Wide Radius Turn

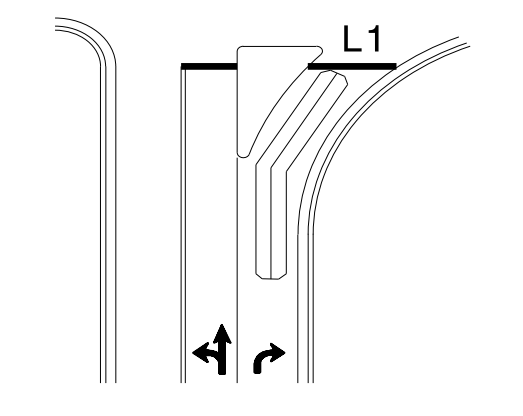

Channelized Turn

Side Street Detection

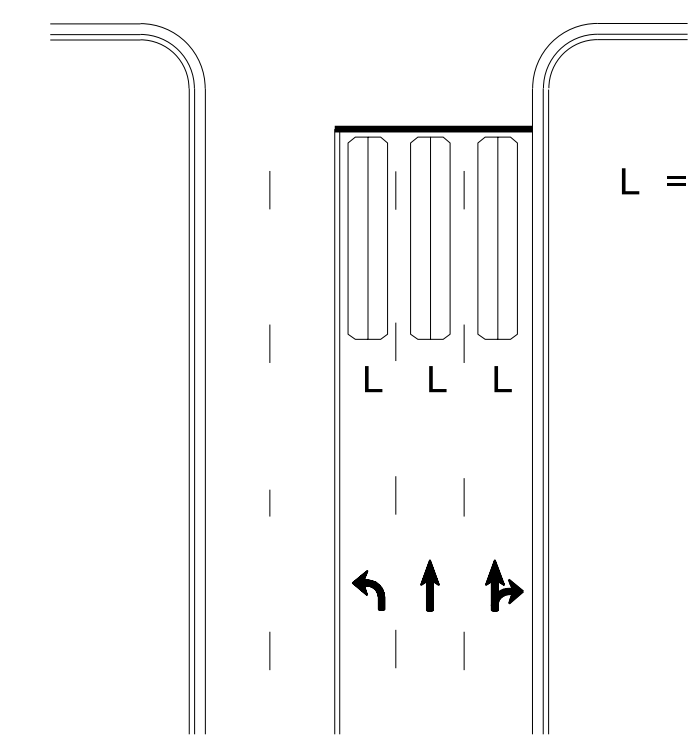

L = 6ft X 40ft
Quadrupole loop
Wired to separate
detectors/channels

Presence Loop Placement at Stop Lines

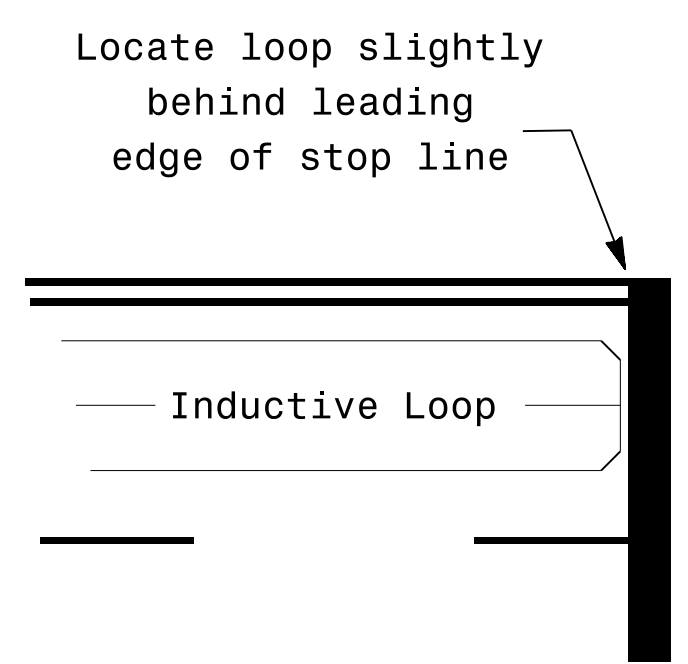

Locate loop slightly
behind leading
edge of stop line

Note:
Loop may be located in advance
of stop line under any of the
following conditions:
1) stop line is greater than 15'
from edge of intersecting
roadway
2) loop detects a permissive or
protected/permissive left turn
3) for an exclusive right turn
lane

Recommended Number of Turns

Single 6' X 6' loop
(when wired separately):

Length of Lead-in ft	Number of Turns
< 250	3
250-375	4
375-525	5
> 525	6

Quadrupole loops: Use 2-4-2 turns
6' X 15' Loops:
Lead-in < 150', use 2 turns
Lead-in > 150', use 3 turns

750 N. Greenfield Pkwy, Garner, NC 27529

Typical Signal Loop Locations

PLAN DATE: January 2015	REVIEWED BY: JPG
PREPARED BY: PLA	REVIEWED BY:
REVISIONS	INIT. DATE

SEAL
NORTH CAROLINA
PROFESSIONAL ENGINEER
PAMELA L. ALEXANDER
23489

1/30/2015

3D:\1116-2015-12-29-SIGNAL\1116-2015-12-29-SIGNAL\Signal Design\Section\Eastern\Region\loop\ypj\ca\2015.dgn
 paalexander