

**This electronic collection of documents is provided
for the convenience of the user
and is Not a Certified Document –**

**The documents contained herein were originally issued
and sealed by the individuals whose names and license
numbers appear on each page, on the dates appearing
with their signature on that page.**

**This file or an individual page
shall not be considered a certified document.**

T.I.P.: R-3100B

CONTRACT NO.: C203829

**STATE OF NORTH CAROLINA
DEPARTMENT OF TRANSPORTATION**

**PAVEMENT MARKING PLAN
CATAWBA COUNTY**

LOCATION: NC 16 NORTH OF SR 1801 (CLAREMONT RD) AND NORTH OF SR 1814 (CALDWELL ROAD)

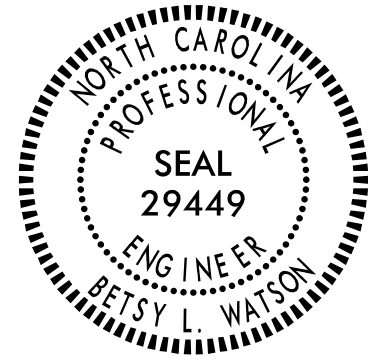
TIP NO. R-3100B	SHEET NO. PMP - 1
<small>DocuSigned by:</small> APPROVED: <u>Betsy L. Watson</u> <small>—55E878B34F8743F—</small> DATE: 9/20/2016	
SEAL 	
DOCUMENT NOT CONSIDERED FINAL UNLESS ALL SIGNATURES COMPLETED	

ROADWAY STANDARD DRAWINGS

THE FOLLOWING ROADWAY STANDARDS AS APPEAR IN "ROADWAY STANDARD DRAWINGS" - PROJECT SERVICES UNIT - N.C. DEPARTMENT OF TRANSPORTATION - RALEIGH, N.C., DATED JANUARY 2012 ARE APPLICABLE TO THIS PROJECT AND BY REFERENCE HEREBY ARE CONSIDERED A PART OF THESE PLANS:

STD. NO.	TITLE
1205.01	PAVEMENT MARKINGS - LINE TYPES & OFFSETS
1205.02	PAVEMENT MARKINGS - 2 LANE & MULTILANE ROADWAYS
1205.04	PAVEMENT MARKINGS - INTERSECTIONS
1205.05	PAVEMENT MARKINGS - TURN LANES
1205.08	PAVEMENT MARKINGS - SYMBOLS & WORD MESSAGES
1205.09	PAVEMENT MARKINGS - PAINTED ISLANDS
1250.01	RAISED PAVEMENT MARKERS - INSTALLATION SPACING
1253.01	RAISED PAVEMENT MARKERS - SNOWPLOWABLE
1261.01	GUARDRAIL & BARRIER DELINEATORS - INSTALLATION SPACING
1261.02	GUARDRAIL & BARRIER DELINEATORS - TYPES & MOUNTING
1262.01	GUARDRAIL END DELINEATION

GENERAL NOTES

THE FOLLOWING GENERAL NOTES APPLY AT ALL TIMES FOR THE DURATION OF THE CONSTRUCTION PROJECT, EXCEPT WHEN OTHERWISE NOTED IN THE PLAN, OR DIRECTED BY THE ENGINEER.

- A) INSTALL PAVEMENT MARKINGS AND PAVEMENT MARKERS ON THE FINAL SURFACE AS FOLLOWS:

ROAD NAME	MARKING	MARKER
ALL ROADS	POLYUREA WITH HIGHLY REFLECTIVE ELEMENTS	SNOWPLOWABLE

- B) TIE PROPOSED PAVEMENT MARKING LINES TO EXISTING PAVEMENT MARKING LINES.
 C) REMOVE/REPLACE ANY CONFLICTING/DAMAGED PAVEMENT MARKINGS AND MARKERS.
 D) PASSING ZONES WILL BE DETERMINED IN THE FIELD AND MUST BE APPROVED BY THE ENGINEER.
 E) STOP BAR LOCATION AT NON-SIGNALIZED INTERSECTIONS MAY BE ADJUSTED AS DIRECTED BY THE ENGINEER.
 F) UNLESS OTHERWISE SPECIFIED, HEATED-IN-PLACE THERMOPLASTIC MAY BE USED IN LIEU OF EXTRUDED THERMOPLASTIC FOR STOP BARS, SYMBOLS, CHARACTERS AND DIAGONALS.

FINAL PAVEMENT MARKING SCHEDULE

SYMBOL	DESCRIPTION	PAY ITEM
T2	WHITE STOPBAR	(24", 120 MIL) THERMOPLASTIC
TU	WHITE DIAGONAL	(12", 90 MIL) THERMOPLASTIC
TV	YELLOW DIAGONAL	(12", 90 MIL) THERMOPLASTIC
UA	LEFT TURN ARROW	(90 MIL) THERMOPLASTIC
UB	RIGHT TURN ARROW	(90 MIL) THERMOPLASTIC
UC	STRAIGHT ARROW	(90 MIL) THERMOPLASTIC
UD	COMBO LEFT/STRAIGHT	(90 MIL) THERMOPLASTIC
UT	U-TURN ARROW	(90 MIL) THERMOPLASTIC
V8	2 FT-6FT/SP WHITE MINISKIP	(4") POLYUREA
V9	2 FT-6FT/SP YELLOW MINISKIP	(4") POLYUREA
VA	WHITE EDGELINE	(4") POLYUREA
VB	YELLOW EDGELINE	(4") POLYUREA
VC	10 FT WHITE SKIP	(4") POLYUREA
VD	3 FT-9 FT/SP WHITE MINISKIP	(4") POLYUREA
VE	WHITE SOLID LANE LINE	(4") POLYUREA
VI	YELLOW DOUBLE CENTER	(4") POLYUREA
VN	WHITE GORELINE	(8") POLYUREA

PLAN REVIEWED BY: N.C.D.O.T. SIGNING AND DELINEATION UNIT

KELVIN JORDAN SIGNING & DELINEATION REGIONAL ENGINEER

DERRICK BEARD SIGNING & DELINEATION PROJECT DESIGN ENGINEER

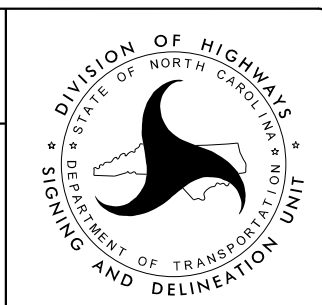

PLAN PREPARED BY:

BETSY L. WATSON, P.E. TRAFFIC ENGINEER



ROSI R. HENNEIN TRANSPORTATION DESIGNER







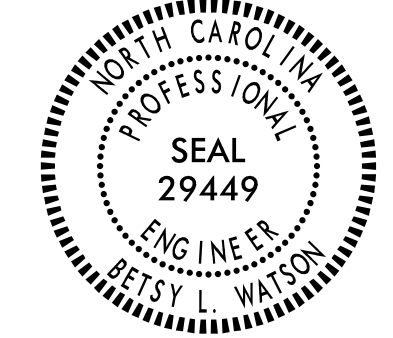





Stantec Consulting Services Inc.
801 Jones Franklin Road
Suite 300
Raleigh, NC 27606
Tel. (919) 851-6866
Fax. (919) 851-7024
www.stantec.com
License No. F-6872

INDEX

SHEET NO.	DESCRIPTION
PMP - 1	PAVEMENT MARKING PLAN TITLE AND SCHEDULE SHEET
PMP - 2 - 13	PAVEMENT MARKING DETAIL

TIP NO. R-3100B	SHEET NO. PMP-2
APPROVED: <i>Betsy L. Watson</i> <small>DocuSigned by: Betsy L. Watson 35E678B34F8743F...</small>	
DATE: 9/19/2016	
SEAL	
	
DOCUMENT NOT CONSIDERED FINAL UNLESS ALL SIGNATURES COMPLETED	
	

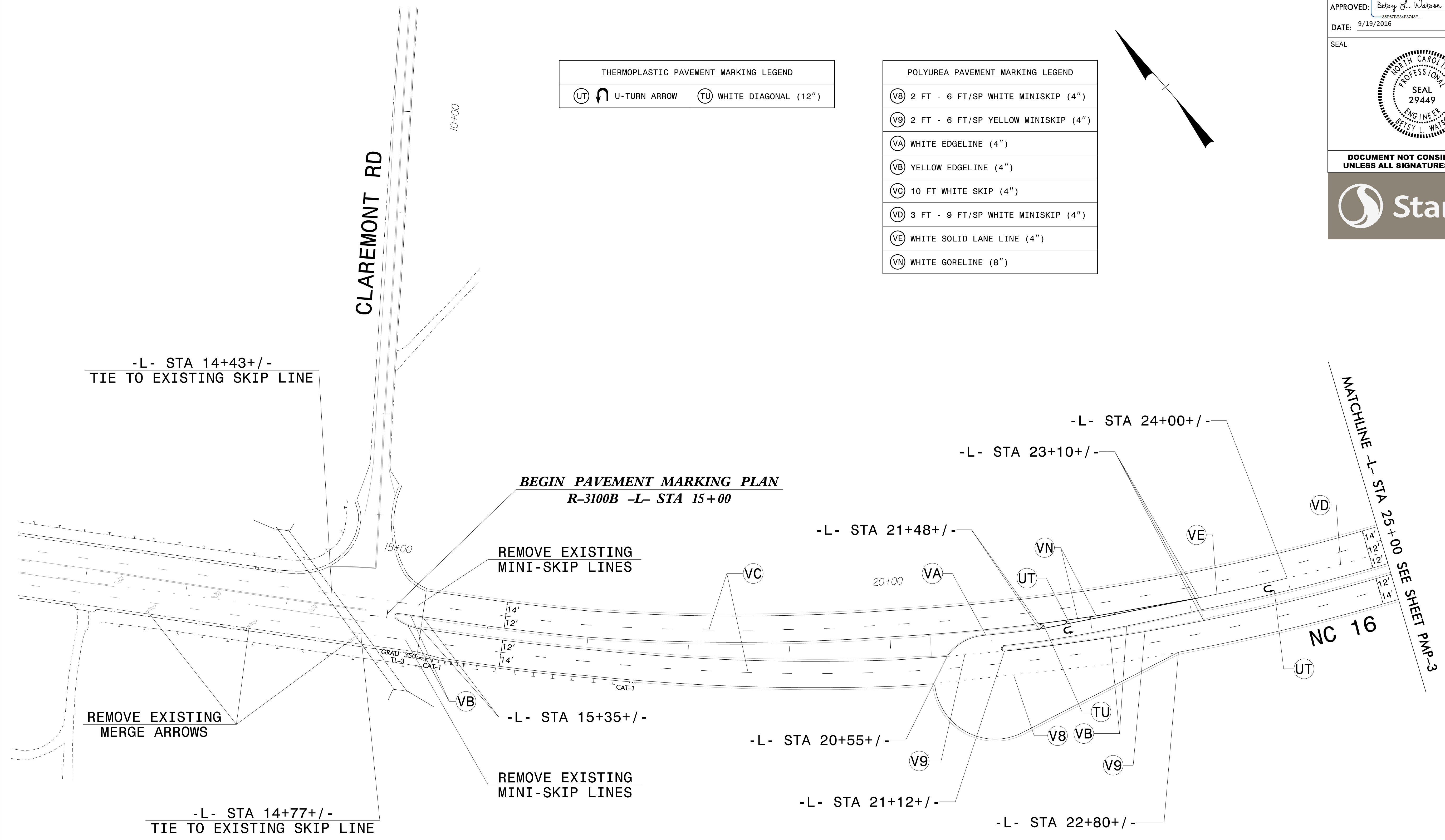
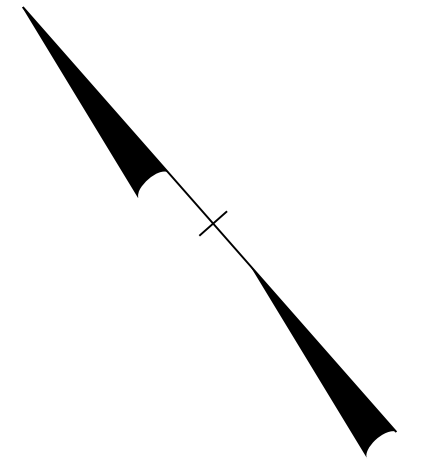

THERMOPLASTIC PAVEMENT MARKING LEGEND	
 U-TURN ARROW	 WHITE DIAGONAL (12")

POLYUREA PAVEMENT MARKING LEGEND	
 2 FT - 6 FT/SP WHITE MINISKIP (4")	
 2 FT - 6 FT/SP YELLOW MINISKIP (4")	
 WHITE EDGELINE (4")	
 YELLOW EDGELINE (4")	
 10 FT WHITE SKIP (4")	
 3 FT - 9 FT/SP WHITE MINISKIP (4")	
 WHITE SOLID LANE LINE (4")	
 WHITE GORELINE (8")	

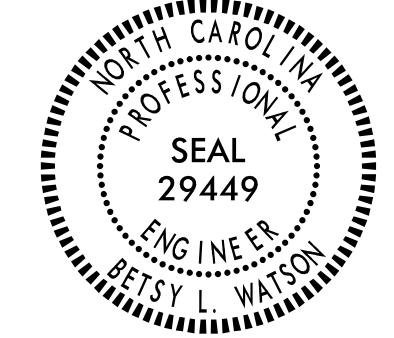

\$\$\$\$\$SYTIME\$\$\$\$\$
 \$\$\$\$DGN\$\$\$\$\$
 \$\$\$USERNAME\$\$\$\$\$

PAVEMENT MARKING DETAIL



TIP NO. R-3100B	SHEET NO. PMP-3
APPROVED: <i>Betsy L. Watson</i> <small>DocuSigned by: Betsy L. Watson 35E678B34F8743F...</small>	
DATE: 9/19/2016	
SEAL 	
DOCUMENT NOT CONSIDERED FINAL UNLESS ALL SIGNATURES COMPLETED	
	

THERMOPLASTIC PAVEMENT MARKING LEGEND	
(UA) LEFT TURN ARROW	(TU) WHITE DIAGONAL (12")
(UB) RIGHT TURN ARROW	
(UT) U-TURN ARROW	

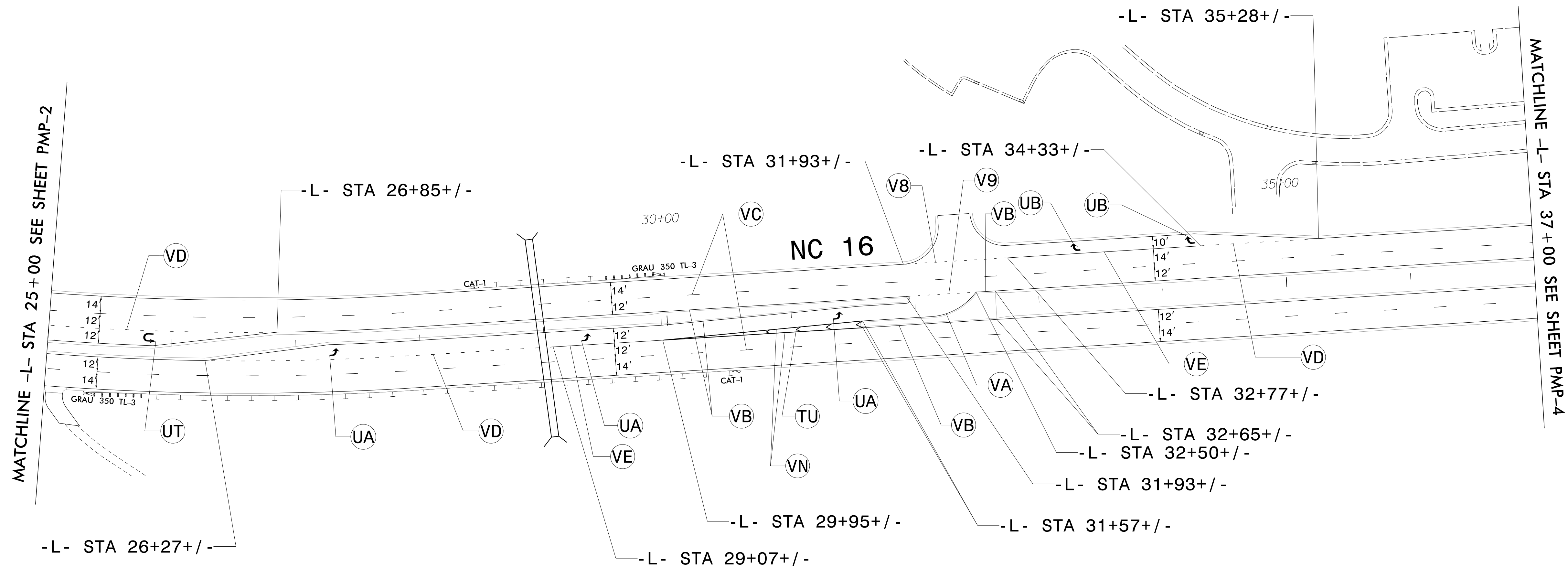
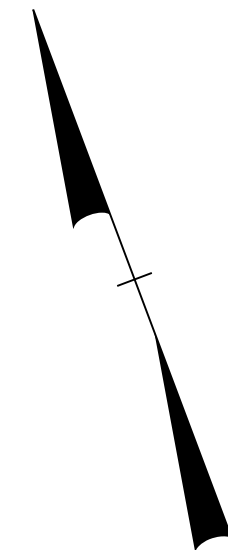
POLYUREA PAVEMENT MARKING LEGEND	
(VB) 2 FT - 6 FT/SP WHITE MINISKIP (4")	
(V9) 2 FT - 6 FT/SP YELLOW MINISKIP (4")	
(VA) WHITE EDGE LINE (4")	
(VB) YELLOW EDGE LINE (4")	
(VC) 10 FT WHITE SKIP (4")	
(VD) 3 FT - 9 FT/SP WHITE MINISKIP (4")	
(VE) WHITE SOLID LANE LINE (8")	
(VN) WHITE GORE LINE (8")	

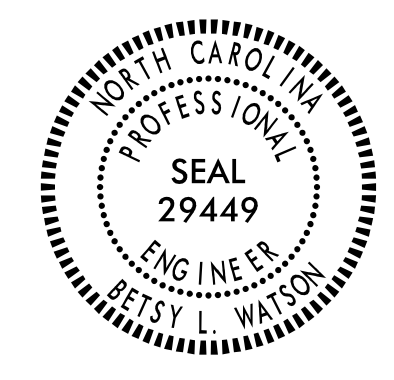

PAVEMENT MARKING DETAIL

TIP NO. R-3100B	SHEET NO. PMP-4
APPROVED: <i>Betsy L. Watson</i> <small>DocuSigned by: Betsy L. Watson 35E07B834F8743F...</small>	
DATE: 9/19/2016	
SEAL 	
DOCUMENT NOT CONSIDERED FINAL UNLESS ALL SIGNATURES COMPLETED	
	

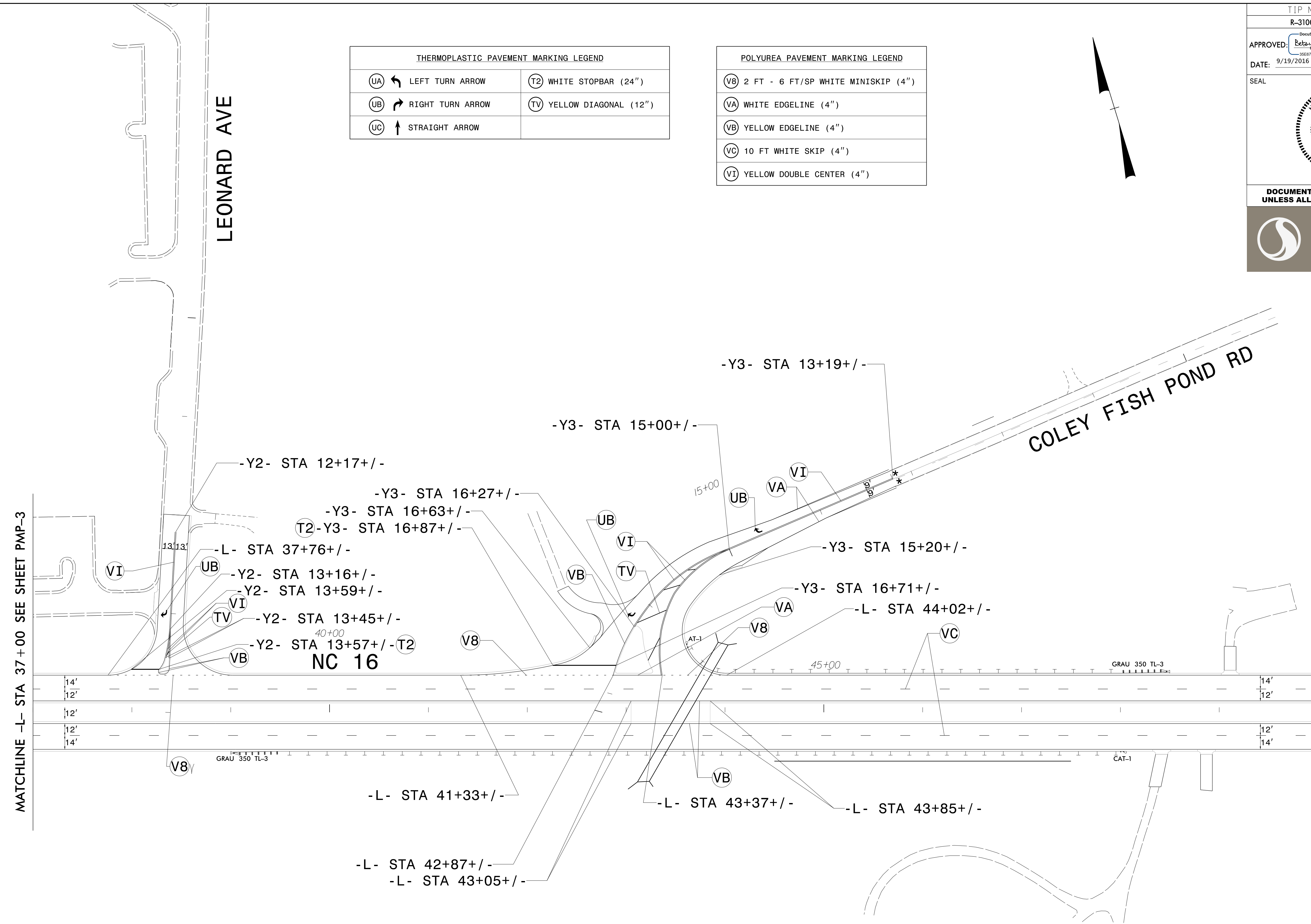
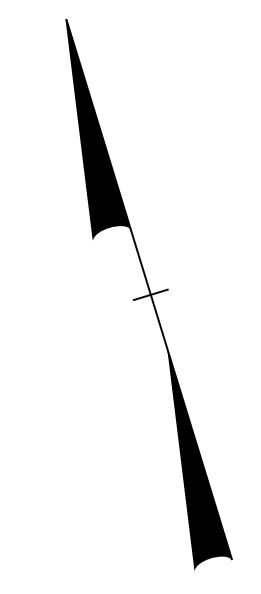

THERMOPLASTIC PAVEMENT MARKING LEGEND	
(UA) ← LEFT TURN ARROW	(T2) WHITE STOPBAR (24")
(UB) ↗ RIGHT TURN ARROW	(TV) YELLOW DIAGONAL (12")
(UC) ↑ STRAIGHT ARROW	

POLYUREA PAVEMENT MARKING LEGEND	
(VB) 2 FT - 6 FT/SP WHITE MINISKIP (4")	
(VA) WHITE EDGELINE (4")	
(VB) YELLOW EDGELINE (4")	
(VC) 10 FT WHITE SKIP (4")	
(VI) YELLOW DOUBLE CENTER (4")	

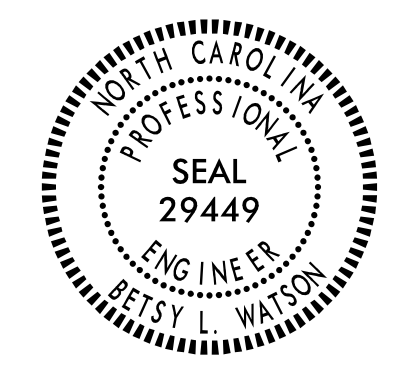

\$\$\$\$\$SYTIME\$\$\$\$\$
 \$\$\$DDGN\$\$\$\$\$
 \$\$\$USERNAME\$\$\$\$\$

PAVEMENT MARKING DETAIL

TIP NO. R-3100B	SHEET NO. PMP-5
APPROVED: <i>Betsy L. Watson</i> <small>DocuSigned by: Betsy L. Watson 35E078834F8743F...</small>	
DATE: 9/19/2016	
SEAL	
	
DOCUMENT NOT CONSIDERED FINAL UNLESS ALL SIGNATURES COMPLETED	
	

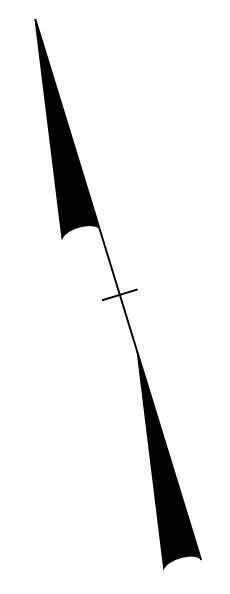

MATCHLINE -L- STA 50+00 SEE SHEET PMP-4

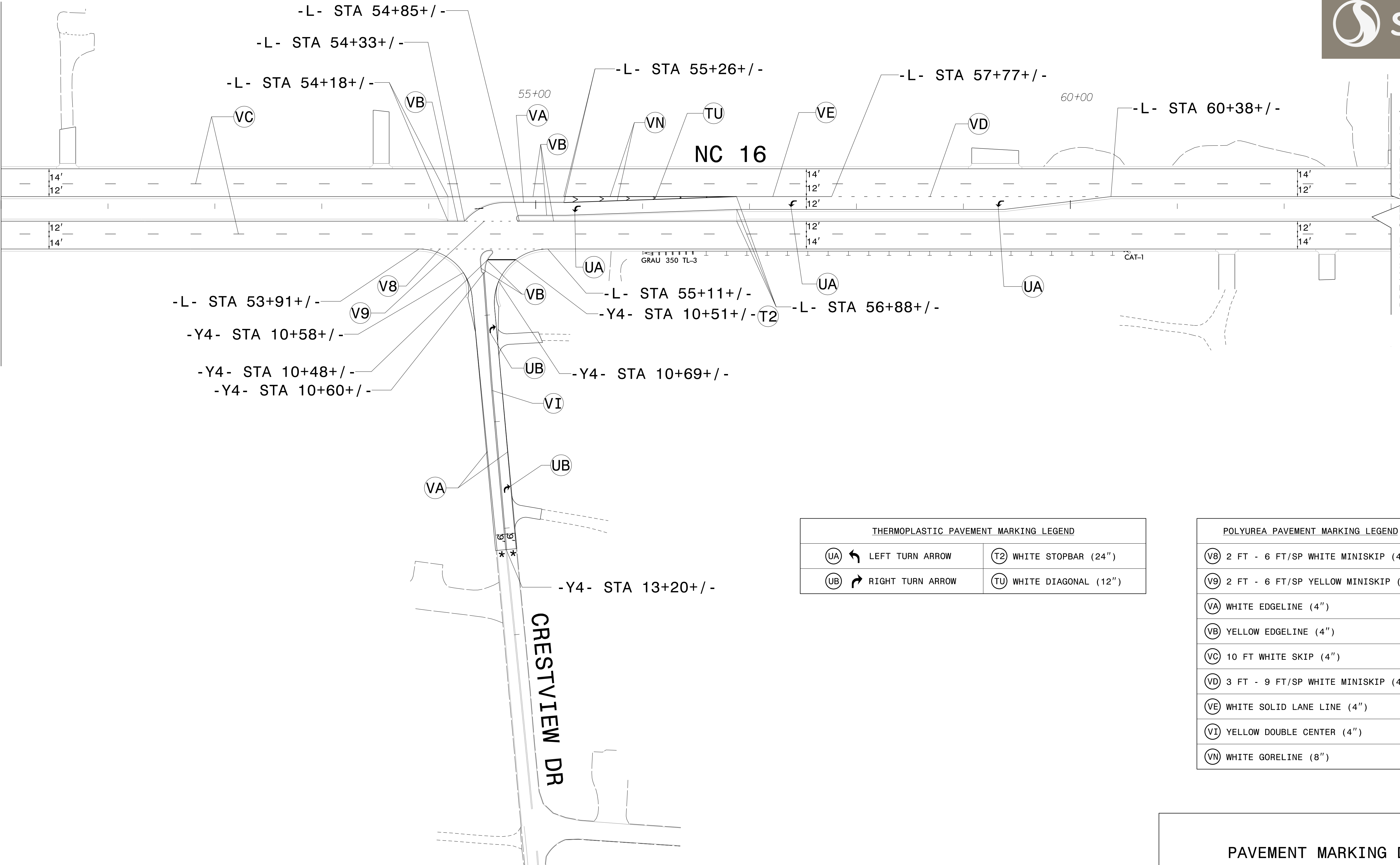

BREAKLINE SEE SHEET PMP-6

THERMOPLASTIC PAVEMENT MARKING LEGEND	
(UA) ←	LEFT TURN ARROW
(UB) →	RIGHT TURN ARROW
(T2)	WHITE STOPBAR (24")
(TU)	WHITE DIAGONAL (12")

POLYUREA PAVEMENT MARKING LEGEND	
(V8)	2 FT - 6 FT/SP WHITE MINISKIP (4")
(V9)	2 FT - 6 FT/SP YELLOW MINISKIP (4")
(VA)	WHITE EDGELINE (4")
(VB)	YELLOW EDGELINE (4")
(VC)	10 FT WHITE SKIP (4")
(VD)	3 FT - 9 FT/SP WHITE MINISKIP (4")
(VE)	WHITE SOLID LANE LINE (4")
(VI)	YELLOW DOUBLE CENTER (4")
(VN)	WHITE GORELINE (8")

PAVEMENT MARKING DETAIL

\$\$\$\$\$SYTIME\$\$\$\$\$
\$\$\$\$\$DGN\$\$\$\$\$
\$\$\$\$\$USERNAME\$\$\$\$\$

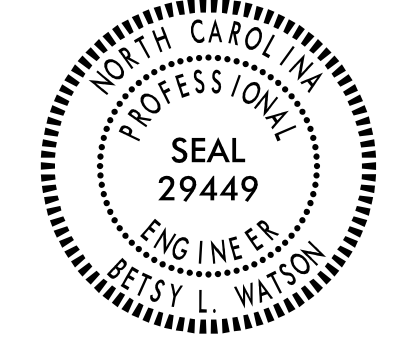
TIP NO. R-3100B	SHEET NO. PMP-6
APPROVED: <i>Betsy L. Watson</i> DocuSigned by: Betsy L. Watson 35E078B34F8743F...	
DATE: 9/19/2016	
SEAL 	
DOCUMENT NOT CONSIDERED FINAL UNLESS ALL SIGNATURES COMPLETED	



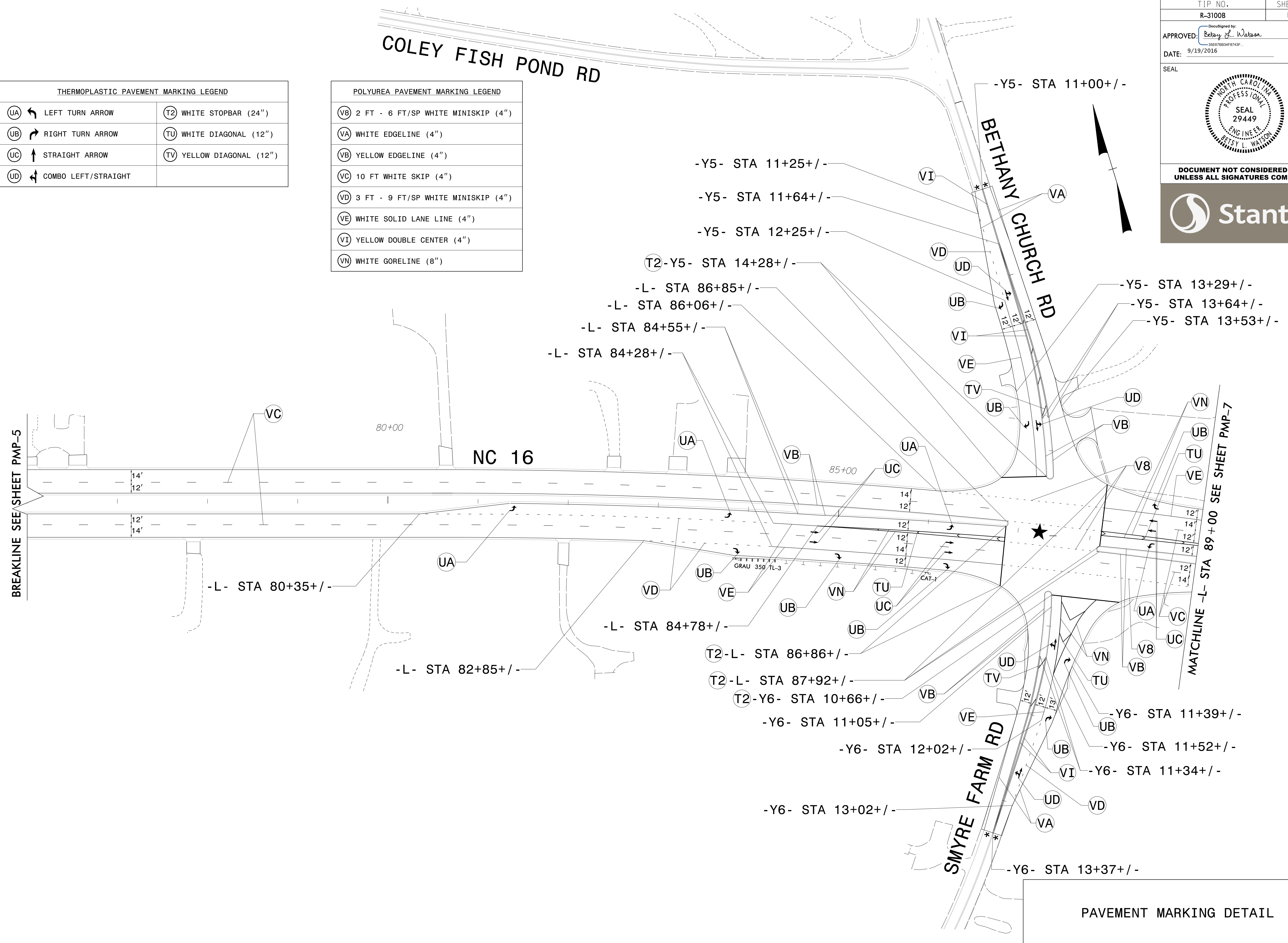

UA LEFT TURN ARROW	T2 WHITE STOPBAR (24")
UB RIGHT TURN ARROW	TU WHITE DIAGONAL (12")
UC STRAIGHT ARROW	TV YELLOW DIAGONAL (12")
UD COMBO LEFT/STRAIGHT	

VB 2 FT - 6 FT/SP WHITE MINISKIP (4")
VA WHITE EDGELINE (4")
VB YELLOW EDGELINE (4")
VC 10 FT WHITE SKIP (4")
VD 3 FT - 9 FT/SP WHITE MINISKIP (4")
VE WHITE SOLID LANE LINE (4")
VI YELLOW DOUBLE CENTER (4")
VN WHITE GORELINE (8")

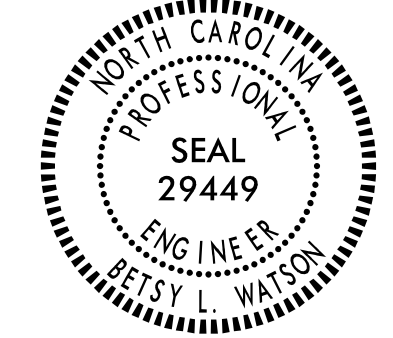

\$\$\$\$\$SYTIME\$\$\$\$\$
 \$\$\$\$\$\$DGN\$\$\$\$\$
 \$\$\$\$\$\$USERNAME\$\$\$\$\$

PAVEMENT MARKING DETAIL

TIP NO. R-3100B	SHEET NO. PMP-7
APPROVED: <i>Betsy L. Watson</i> <small>DocuSigned by: Betsy L. Watson 3556788348743F</small>	
DATE: 9/19/2016	
SEAL 	
DOCUMENT NOT CONSIDERED FINAL UNLESS ALL SIGNATURES COMPLETED	
	

THERMOPLASTIC PAVEMENT MARKING LEGEND	
(UA) ← LEFT TURN ARROW	(TU) WHITE DIAGONAL (12")
(UB) → RIGHT TURN ARROW	
(UC) ↑ STRAIGHT ARROW	

POLYUREA PAVEMENT MARKING LEGEND	
(V8) 2 FT - 6 FT/SP WHITE MINISKIP (4")	
(VB) YELLOW EDGELINE (4")	
(VC) 10 FT WHITE SKIP (4")	
(VD) 3 FT - 9 FT/SP WHITE MINISKIP (4")	
(VE) WHITE SOLID LANE LINE (4")	
(VN) WHITE GORELINE (8")	

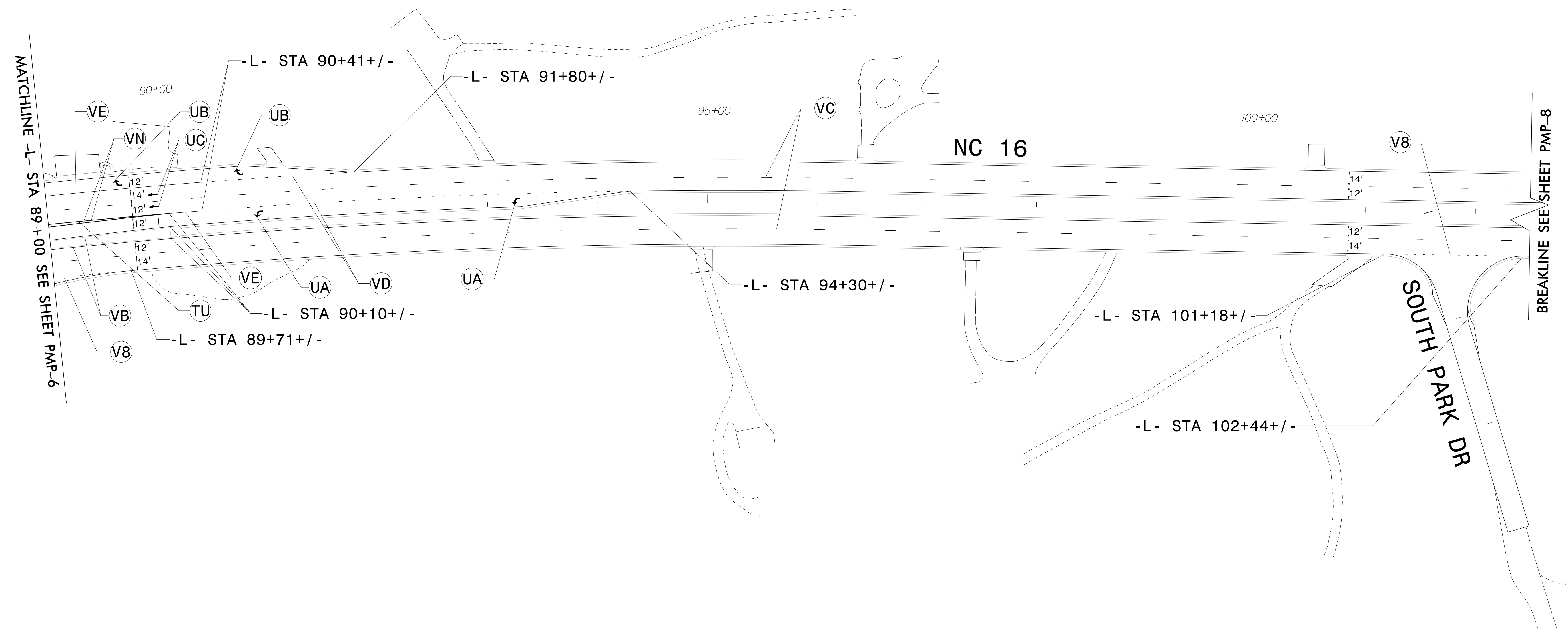
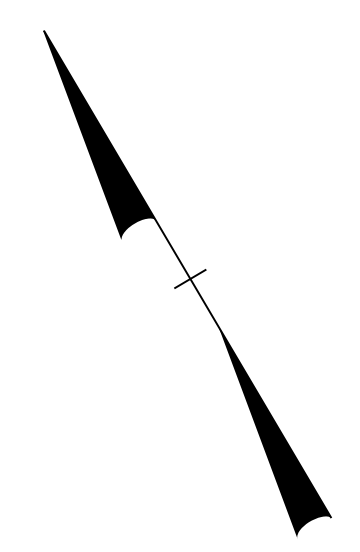



MATCHLINE -L- STA 89+00 SEE SHEET PMP-6

BREAKLINE SEE SHEET PMP-8

\$\$\$\$\$SYTIME\$\$\$\$\$
\$\$\$\$\$DGN\$\$\$\$\$
\$\$\$\$\$USERNAME\$\$\$\$\$

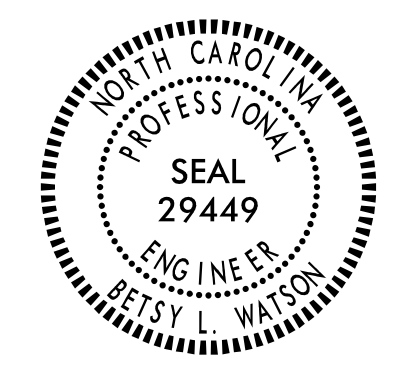
PAVEMENT MARKING DETAIL

TIP NO. R-3100B	SHEET NO. PMP-8
APPROVED: <i>Betsy L. Watson</i> <small>DocuSigned by: Betsy L. Watson 35E678B34F8743F...</small>	
DATE: 9/19/2016	
SEAL	
	
DOCUMENT NOT CONSIDERED FINAL UNLESS ALL SIGNATURES COMPLETED	
	



THERMOPLASTIC PAVEMENT MARKING LEGEND	
(UT)	U-TURN ARROW

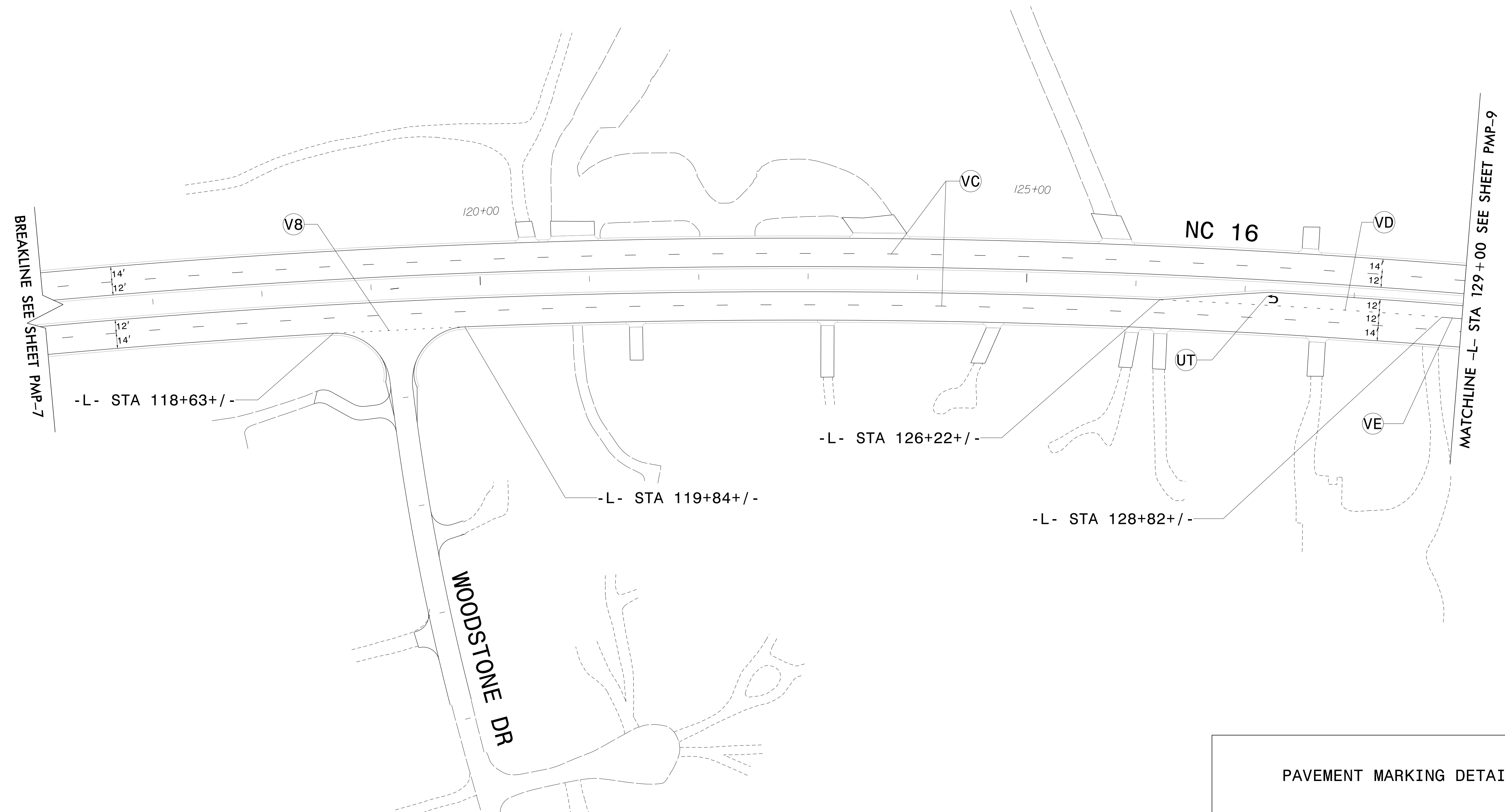
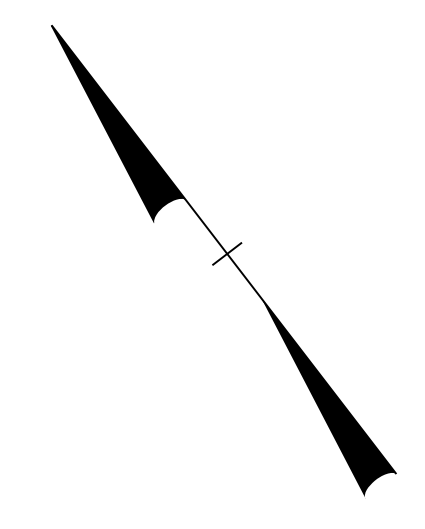

POLYUREA PAVEMENT MARKING LEGEND	
(V8)	2 FT - 6 FT/SP WHITE MINISKIP (4")
(VC)	10 FT WHITE SKIP (4")
(VD)	3 FT - 9 FT/SP WHITE MINISKIP (4")
(VE)	WHITE SOLID LANE LINE (4")



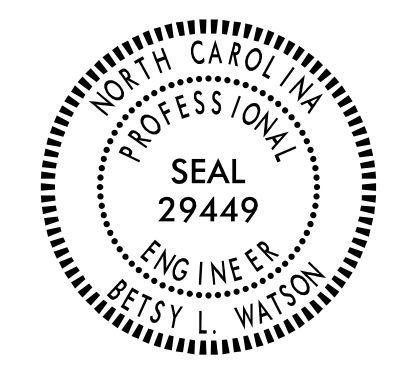







\$\$\$\$\$SYTIME\$\$\$\$\$
 \$\$\$DDGN\$\$\$\$\$
 \$\$\$USERNAME\$\$\$\$\$

PAVEMENT MARKING DETAIL

TIP NO. R-3100B	SHEET NO. PMP-9
APPROVED: <i>Betsy L. Watson</i> <small>DocuSigned by: Betsy L. Watson 35E078B34F8743F...</small>	
DATE: 9/19/2016	
SEAL 	
DOCUMENT NOT CONSIDERED FINAL UNLESS ALL SIGNATURES COMPLETED	
	

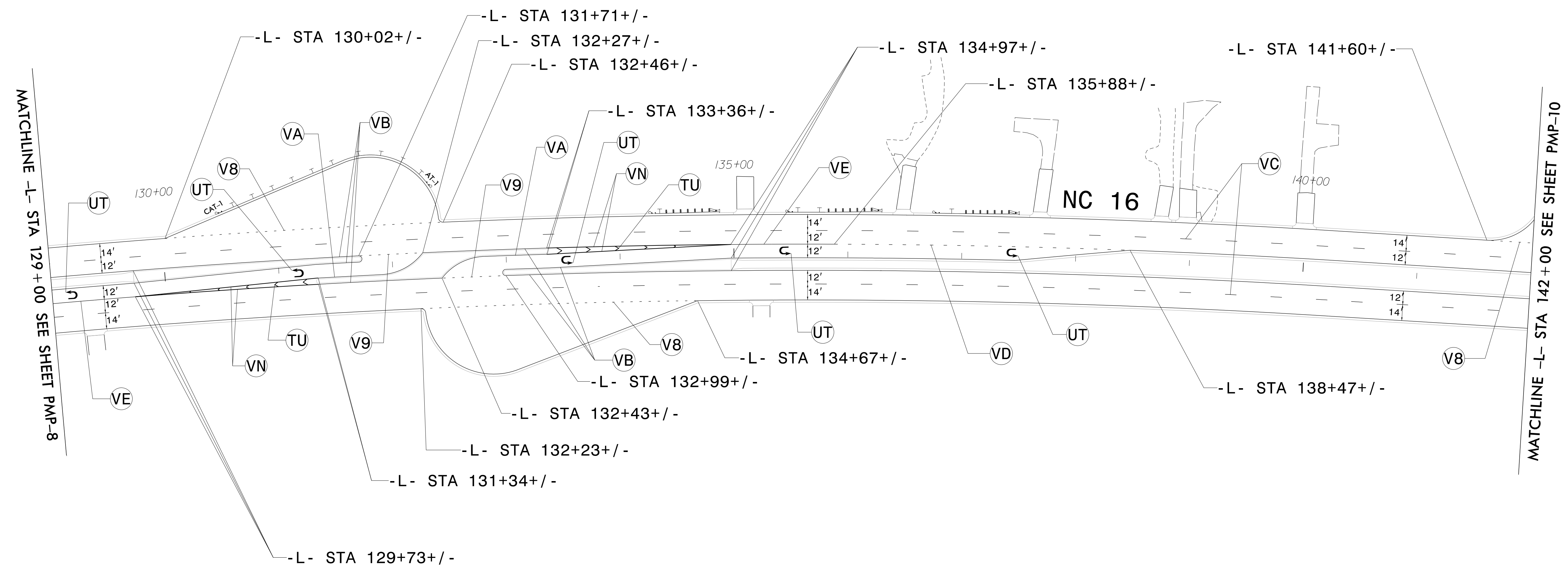
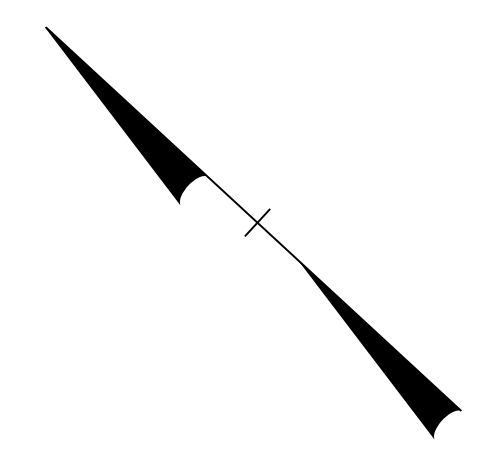

THERMOPLASTIC PAVEMENT MARKING LEGEND	
 U-TURN ARROW	 WHITE DIAGONAL (12")

POLYUREA PAVEMENT MARKING LEGEND	
 2 FT - 6 FT/SP WHITE MINISKIP (4")	
 2 FT - 6 FT/SP YELLOW MINISKIP (4")	
 WHITE EDGELINE (4")	
 YELLOW EDGELINE (4")	
 10 FT WHITE SKIP (4")	
 3 FT - 9 FT/SP YELLOW MINISKIP (4")	
 WHITE SOLID LANE LINE (4")	
 WHITE GORELINE (8")	





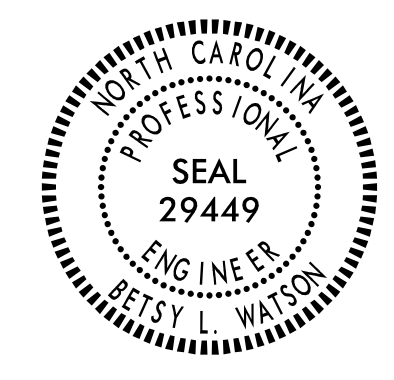

\$\$\$\$\$SYTIME\$\$\$\$\$
 \$\$\$\$\$\$DGN\$\$\$\$\$
 \$\$\$\$\$\$USERNAME\$\$\$\$\$

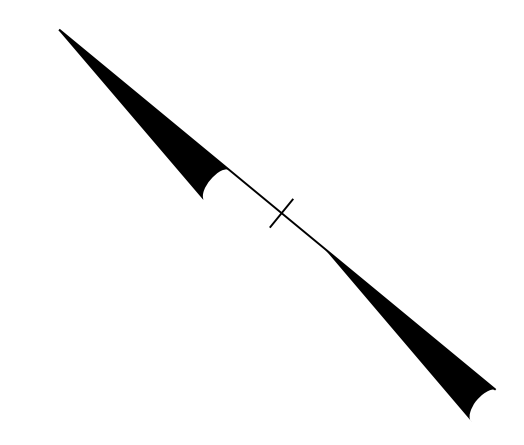
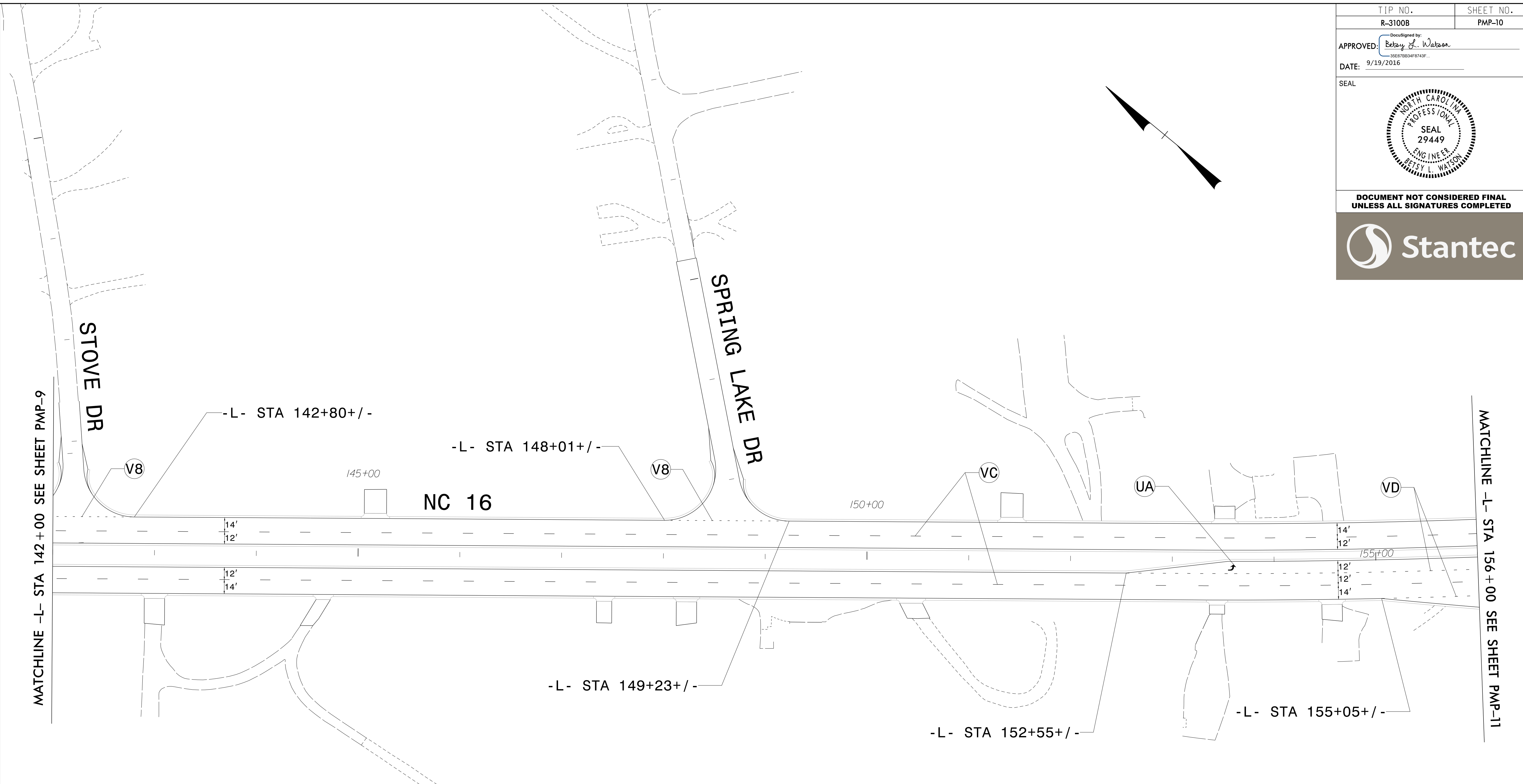
PAVEMENT MARKING DETAIL

TIP NO. R-3100B	SHEET NO. PMP-10
APPROVED: <i>Betsy L. Watson</i> <small>DocuSigned by: Betsy L. Watson 35E078B34F8743F...</small>	
DATE: 9/19/2016	
SEAL 	
DOCUMENT NOT CONSIDERED FINAL UNLESS ALL SIGNATURES COMPLETED	
	



THERMOPLASTIC PAVEMENT MARKING LEGEND	
	LEFT TURN ARROW

POLYUREA PAVEMENT MARKING LEGEND	
	2 FT - 6 FT/SP WHITE MINISKIP (4")
	10 FT WHITE SKIP (4")
	3 FT - 9 FT/SP WHITE MINISKIP (4")

\$\$\$\$\$SYTIME\$\$\$\$\$
 \$\$\$DDGN\$\$\$\$\$
 \$\$\$USERNAME\$\$\$\$\$

PAVEMENT MARKING DETAIL

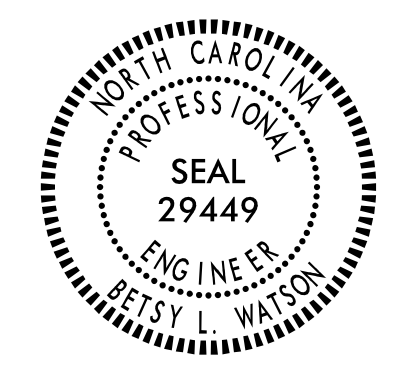
TIP NO. R-3100B	SHEET NO. PMP-11
APPROVED: <i>Betsy L. Watson</i> -35678348743F-	
DATE: 9/20/2016	
SEAL	
	
DOCUMENT NOT CONSIDERED FINAL UNLESS ALL SIGNATURES COMPLETED	

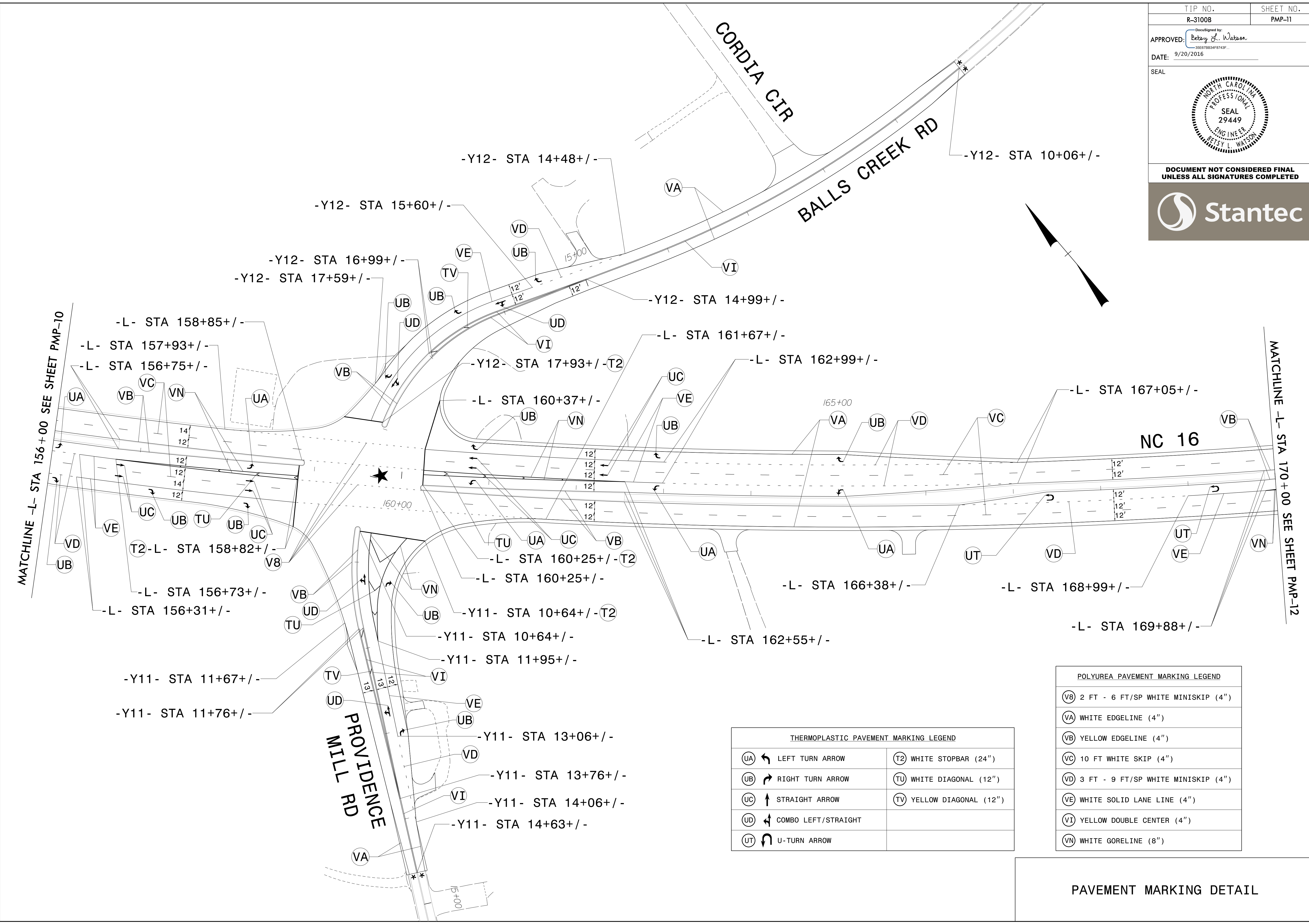





THERMOPLASTIC PAVEMENT MARKING LEGEND	
(UA) ←	LEFT TURN ARROW
(UB) →	RIGHT TURN ARROW
(UC) ↑	STRAIGHT ARROW
(UD) ↙	COMBO LEFT/STRAIGHT
(UT) ↻	U-TURN ARROW
(T2)	WHITE STOPBAR (24")
(TU)	WHITE DIAGONAL (12")
(TV)	YELLOW DIAGONAL (12")







POLYUREA PAVEMENT MARKING LEGEND	
(VB)	2 FT - 6 FT/SP WHITE MINISKIP (4")
(VA)	WHITE EDGELINE (4")
(VB)	YELLOW EDGELINE (4")
(VC)	10 FT WHITE SKIP (4")
(VD)	3 FT - 9 FT/SP WHITE MINISKIP (4")
(VE)	WHITE SOLID LANE LINE (4")
(VI)	YELLOW DOUBLE CENTER (4")
(VN)	WHITE GORELINE (8")

PAVEMENT MARKING DETAIL

\$\$\$\$\$SYTIME\$\$\$\$\$
 \$\$\$DDGN\$\$\$\$\$
 \$\$\$USERNAME\$\$\$\$\$

TIP NO. R-3100B	SHEET NO. PMP-12
APPROVED: <i>Betsy L. Watson</i> <small>DocuSigned by: Betsy L. Watson 35E078B34F8743F...</small>	
DATE: 9/19/2016	
SEAL	
	
DOCUMENT NOT CONSIDERED FINAL UNLESS ALL SIGNATURES COMPLETED	
	

THERMOPLASTIC PAVEMENT MARKING LEGEND	
 	U-TURN ARROW
	WHITE DIAGONAL (12")

POLYUREA PAVEMENT MARKING LEGEND	
	2 FT - 6 FT/SP WHITE MINISKIP (4")
	2 FT - 6 FT/SP YELLOW MINISKIP (4")
	WHITE EDGELINE (4")
	YELLOW EDGELINE (4")
	10 FT WHITE SKIP (4")
	WHITE GORELINE (8")

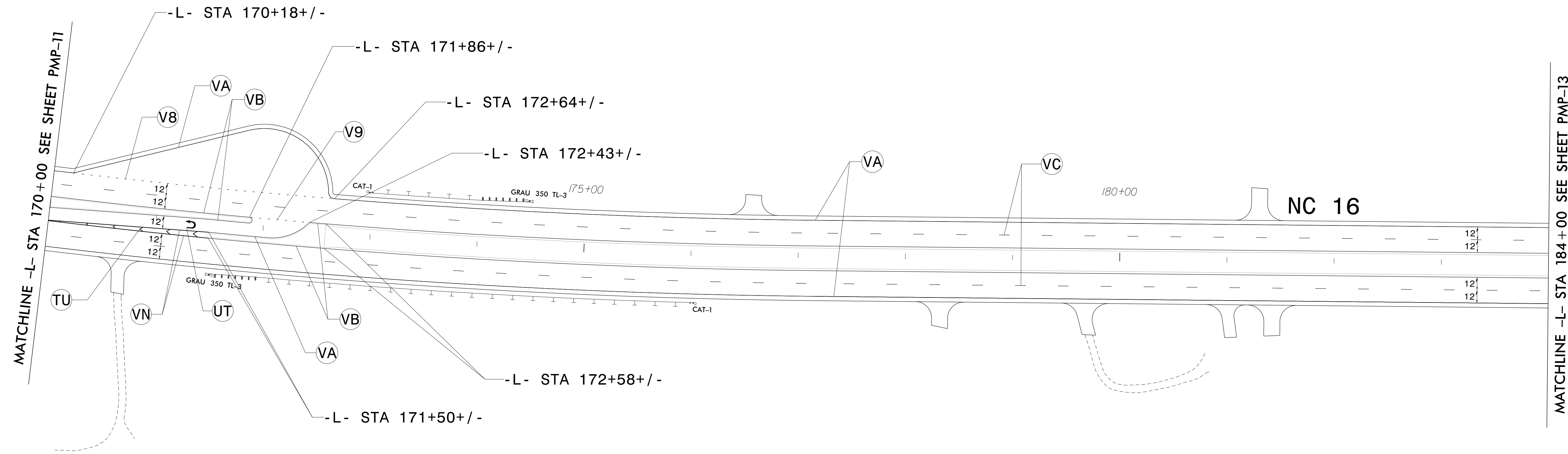
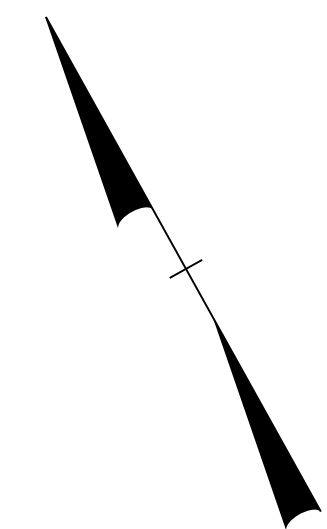

\$\$\$\$\$SYTIME\$\$\$\$\$
 \$\$\$DDGN\$\$\$\$\$
 \$\$\$USERNAME\$\$\$\$\$

PAVEMENT MARKING DETAIL

APPROVED: *Betsy L. Watson*

DATE: 9/19/2016



DOCUMENT NOT CONSIDERED FINAL
UNLESS ALL SIGNATURES COMPLETED



POLYUREA PAVEMENT MARKING LEGEND	
(VA)	WHITE EDGELINE (4")
(VC)	10 FT WHITE SKIP (4")

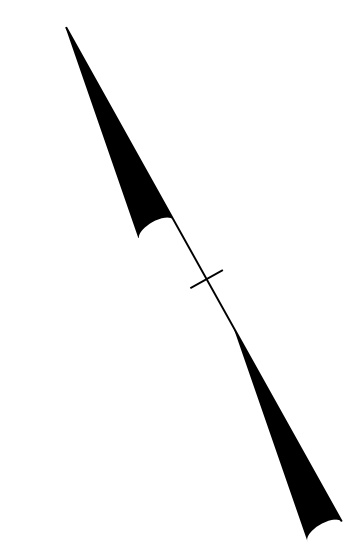

END R-3100B PAVEMENT MARKING PLAN
BEGIN R-3100A -L- STA 198+28

MATCHLINE -L- STA 184+00 SEE SHEET PMP-12

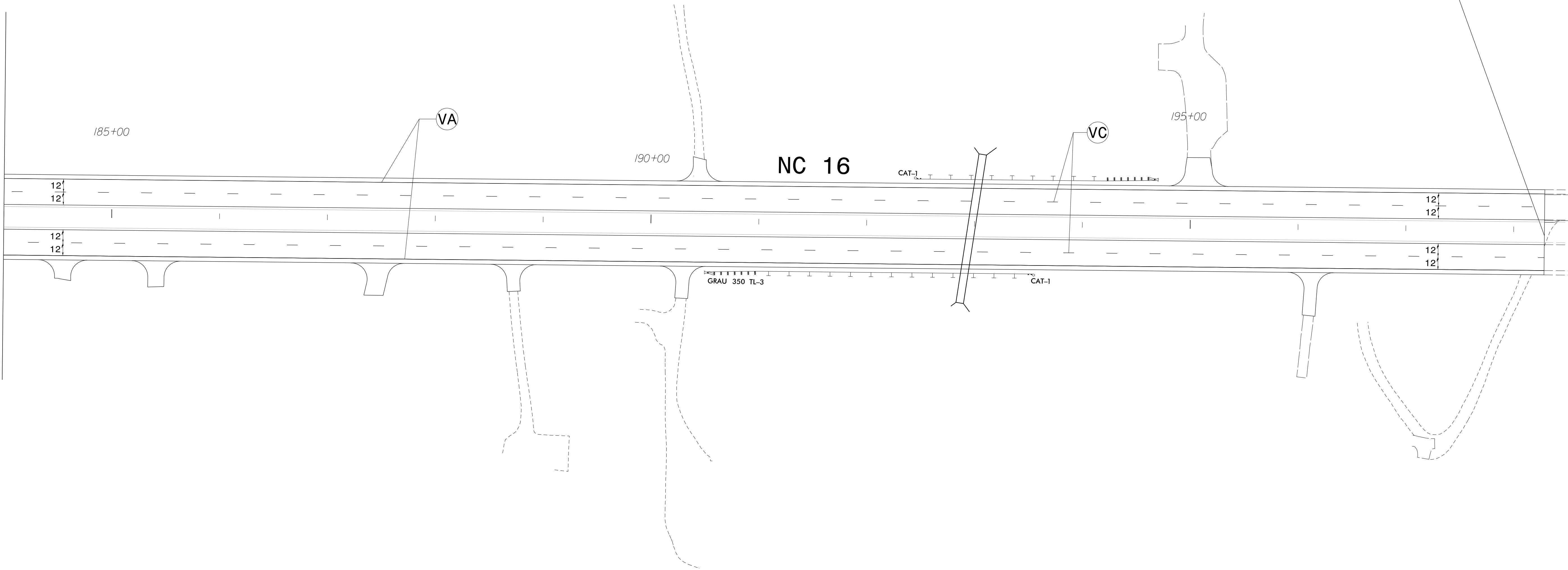

\$\$\$\$\$SYTIME\$\$\$\$\$
 \$\$\$DDGN\$\$\$\$\$
 \$\$\$USERNAME\$\$\$\$\$

PAVEMENT MARKING DETAIL