

EDI MODEL 2018ECLIP-NC CONFLICT MONITOR

PROGRAMMING DETAIL

(remove jumpers and set switches as shown)

REMOVE DIODE JUMPERS 1-5, 1-6, 1-9, 1-11, 1-15, 2-5, 2-6, 2-9, 2-11, 2-13, 2-15, 4-14, 5-9, 5-11, 5-13, 6-9, 6-11, 6-13, 6-15, 9-11, 9-13, 9-15, 11-13, 11-15, and 13-15.

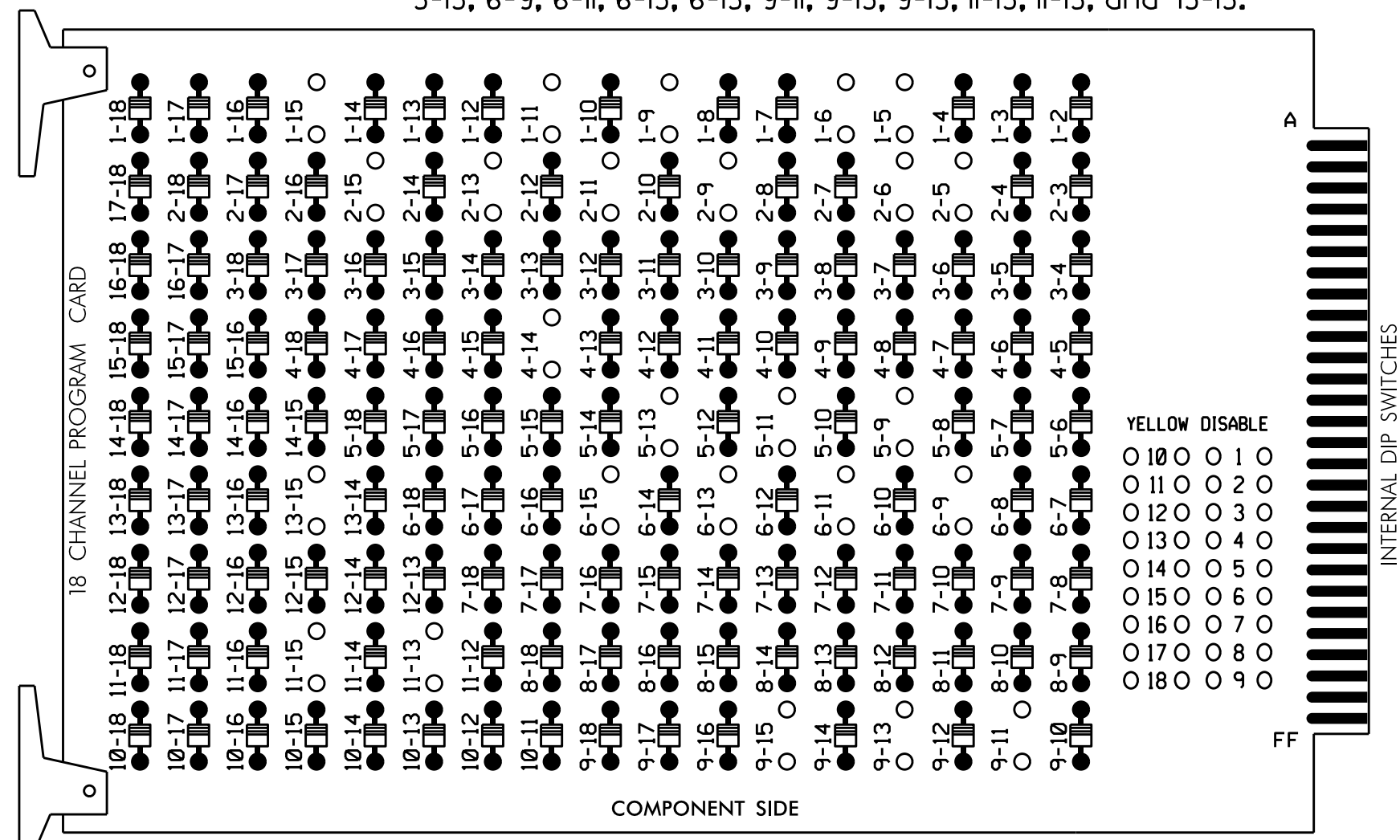

REMOVE JUMPERS AS SHOWN

NOTES:

- Card is provided with all diode jumpers in place. Removal of any jumper allows its channels to run concurrently.
- Ensure jumpers SEL2-SEL5 and SEL9 are present on the monitor board.
- Ensure that Red Enable is active at all times during normal operation.
- Integrate monitor with Ethernet network in cabinet.

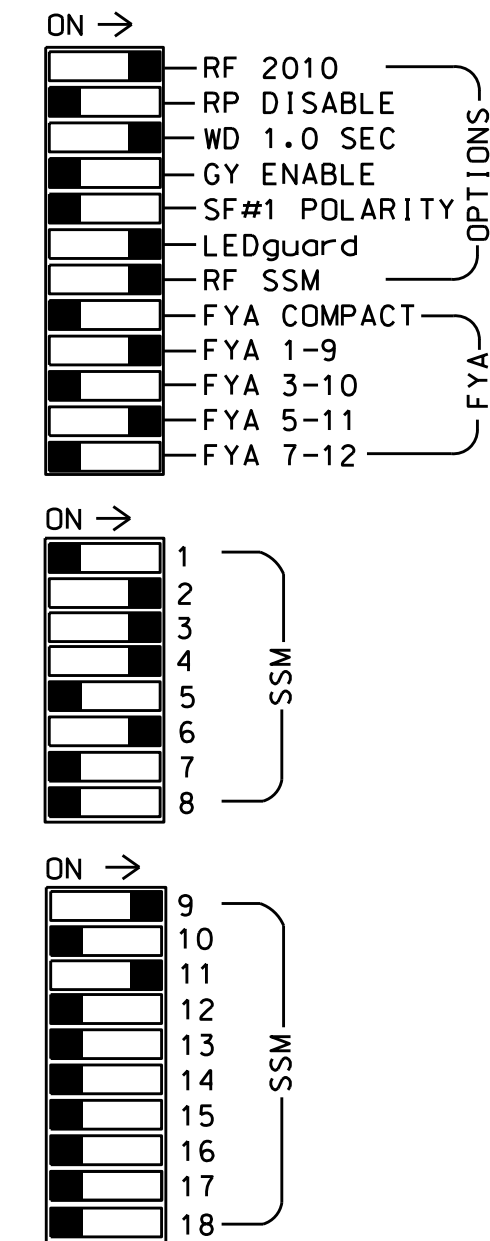
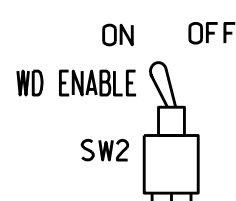

■ = DENOTES POSITION OF SWITCH

NOTES

- To prevent "flash-conflict" problems, insert red flash program blocks for all unused vehicle load switches in the output file. The installer shall verify that signal heads flash in accordance with the Signal Plans.
- Enable Simultaneous Gap-Out for all phases.
- Program phases 2 and 6 for Variable Initial and Gap Reduction.
- Program phases 2 and 6 for Start Up In Green.
- Program phases 2, 4 and 6 for 'STARTUP PED CALL'.
- Program phases 2 and 6 for Yellow Flash, and overlap 1 as Wag Overlaps.
- The cabinet and controller are part of the Asheville Signal System.

EQUIPMENT INFORMATION

CONTROLLER.....2070E
 CABINET.....332 W/ AUX
 SOFTWARE.....ECONOLITE OASIS
 CABINET MOUNT.....BASE
 OUTPUT FILE POSITIONS...18 WITH AUX. OUTPUT FILE
 LOAD SWITCHES USED.....S1,S2,S3,S4,S5,S6,S7,S8,S9,
 AUX S1,AUX S4
 PHASES USED.....1,2,2PED,3,4,4PED,5,6,6PED
 OVERLAP "A".....1+2
 OVERLAP "B".....NOT USED
 OVERLAP "C".....5+6
 OVERLAP "D".....NOT USED

PROJECT REFERENCE NO.	SHEET NO.
U-4715B	Sig. 185.1

SIGNAL HEAD HOOK-UP CHART

LOAD SWITCH NO.	S1	S2	S3	S4	S5	S6	S7	S8	S9	S10	S11	S12	AUX S1	AUX S2	AUX S3	AUX S4	AUX S5	AUX S6
CMU CHANNEL NO.	1	2	13	3	4	14	5	6	15	7	8	16	9	10	17	11	12	18
PHASE	1	2	2 PED	3	4	4 PED	5	6	6 PED	7	8	8 PED	OLA	OLB	SPARE	OLC	OLD	SPARE
SIGNAL HEAD NO.	11	21,22	P21, P22	31,32	41,42	P41, P42	51	61,62	P61, P62	NU	NU	NU	11	NU	NU	51	NU	NU
RED		128		116	101			134										
YELLOW	*	129		117	102		*	135										
GREEN		130		118	103			136										
RED ARROW													A121			A114		
YELLOW ARROW													A122			A115		
FLASHING YELLOW ARROW													A123			A116		
GREEN ARROW	127						133											
Hand			113		104		119											
Walking			115		106		121											

NU = Not Used
 * Denotes install load resistor. See load resistor installation detail this sheet.
 ★ See pictorial of head wiring in detail below.

INPUT FILE POSITION LAYOUT

(front view)

FILE "I"	1	2	3	4	5	6	7	8	9	10	11	12	13	14
U	∅ 1	∅ 2	∅ 3	∅ 4	∅ 5	∅ 6	∅ 7	∅ 8	∅ 9	∅ 10	∅ 11	∅ 12	∅ 13	∅ 14
L	1A	2A	3A	4A	5A	6A	7A	8A	9A	10A	11A	12A	13A	14A
U	NOT USED	∅ 2	∅ 3	∅ 4	∅ 5	∅ 6	∅ 7	∅ 8	∅ 9	∅ 10	∅ 11	∅ 12	∅ 13	∅ 14
L	2B	3B	4B	5B	6B	7B	8B	9B	10B	11B	12B	13B	14B	FS

EX.: 1A, 2A, ETC. = LOOP NO.'S

FS = FLASH SENSE
 ST = STOP TIME

⊗ Wired Input - Do not populate slot with detector card

COUNTDOWN PEDESTRIAN SIGNAL OPERATION

Countdown Ped Signals are required to display timing only during Ped Clearance Interval. Consult Ped Signal Module user's manual for instructions on selecting this feature.

INPUT FILE CONNECTION & PROGRAMMING CHART

LOOP NO.	LOOP TERMINAL	INPUT FILE POS.	PIN NO.	INPUT ASSIGNMENT NO.	DETECTOR NO.	NEMA PHASE	CALL	EXTEND	FULL TIME DELAY	STRETCH TIME	DELAY TIME
1A ¹	TB2-1,2	I1U	56	18	1	1	Y	Y			15
	-	J4U	48	10	26	6	Y	Y	Y		3
2A	TB2-5,6	I2U	39	1	2	2	Y	Y			
2B	TB2-7,8	I2L	43	5	12	2	Y	Y			
3A	TB4-9,10	I6U	41	3	4	3	Y	Y			3
3B	TB4-11,12	I6L	45	7	14	3	Y	Y			15
4A	TB6-1,2	I7U	65	27	34	4	Y	Y			10
5A ²	TB3-1,2	J1U	55	17	5	5	Y	Y	Y		15
	-	I4U	47	9	22	2	Y	Y	Y		3
6A	TB3-5,6	J2U	40	2	6	6	Y	Y			
6B	TB3-7,8	J2L	44	6	16	6	Y	Y			
PED PUSH BUTTONS											
P21,P22	TB8-4,6	I12U	67	29			PED 2	2 PED			
P41,P42	TB8-5,6	I12L	69	31			PED 4	4 PED			
P61,P62	TB8-7,9	I13U	68	30			PED 6	6 PED			

NOTE:
 INSTALL DC ISOLATORS IN INPUT FILE SLOTS 112 AND 113.

- Add jumper from I1-W to J4-W, on rear of input file.
- Add jumper from J1-W to I4-W, on rear of input file.

INPUT FILE POSITION LEGEND: J2L

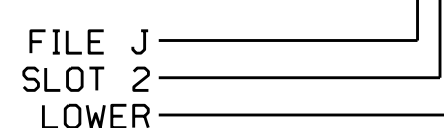

FYA SIGNAL WIRING DETAIL

(wire signal heads as shown)

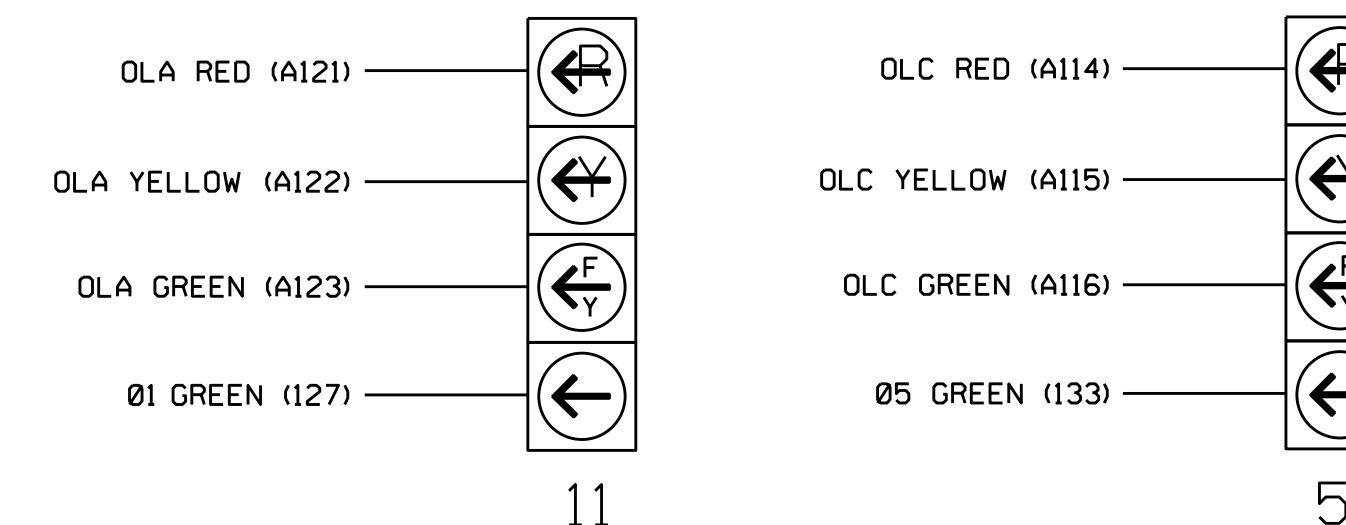

NOTE

The sequence display for signal heads 11 and 51 requires special logic programming. See sheet 2 for programming instructions.

THIS ELECTRICAL DETAIL IS FOR THE SIGNAL DESIGN: 13-1059
 DESIGNED: January 2016
 SEALED: 8/17/2016
 REVISED: N/A

LOAD RESISTOR INSTALLATION DETAIL

(install resistors as shown below)

VALUE (ohms)	WATTAGE
1.5K - 1.9K	25W (min)
2.0K - 3.0K	10W (min)

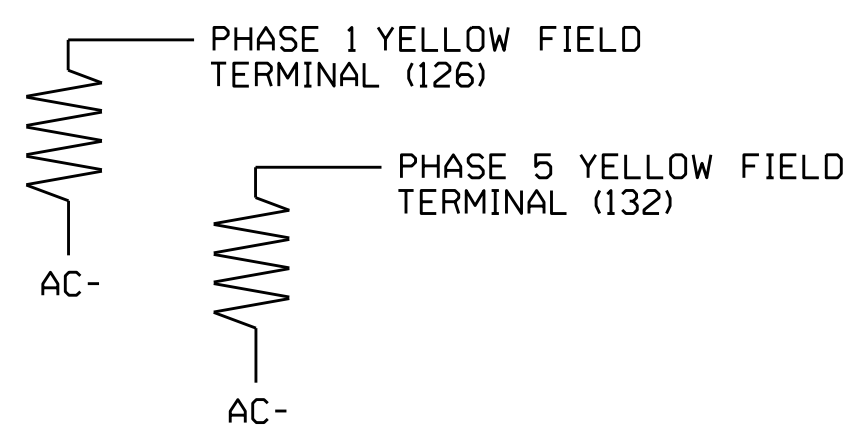

Electrical Detail - Sheet 1 of 2

DOCUMENT NOT CONSIDERED FINAL UNLESS ALL SIGNATURES COMPLETED

Prepared In the Offices of:
 TRANSPORTATION MOBILITY AND SAFETY CONSULTANTS
 750 N. Greenfield Pkwy, Garner, NC 27529

US 25 (Hendersonville Road) at Oak Forest Boulevard/Skyland Crest Shopping Center

Division 13 Buncombe County Asheville

PLAN DATE: July 2016 REVIEWED BY: BAS

PREPARED BY: S. Armstrong REVIEWED BY:

REVISIONS INIT. DATE

Sealed by: Keith M. Minz 9/12/2016

SIG. INVENTORY NO. 13-1059