

EDI MODEL 2018EClip-NC CONFLICT MONITOR PROGRAMMING DETAIL

(remove jumpers and set switches as shown)

REMOVE DIODE JUMPERS 1-5, 1-6, 1-9, 1-10, 1-11, 1-17, 2-5, 2-6, 2-9, 2-10, 2-11, 2-12, 2-17, 3-10, 3-11, 3-17, 4-9, 4-12, 5-9, 5-10, 5-11, 5-12, 6-9, 6-10, 6-11, 6-12, 6-17, 9-10, 9-11, 9-12, 9-17, 10-11, 10-12, 10-17, 11-12, 11-17, and 12-17.

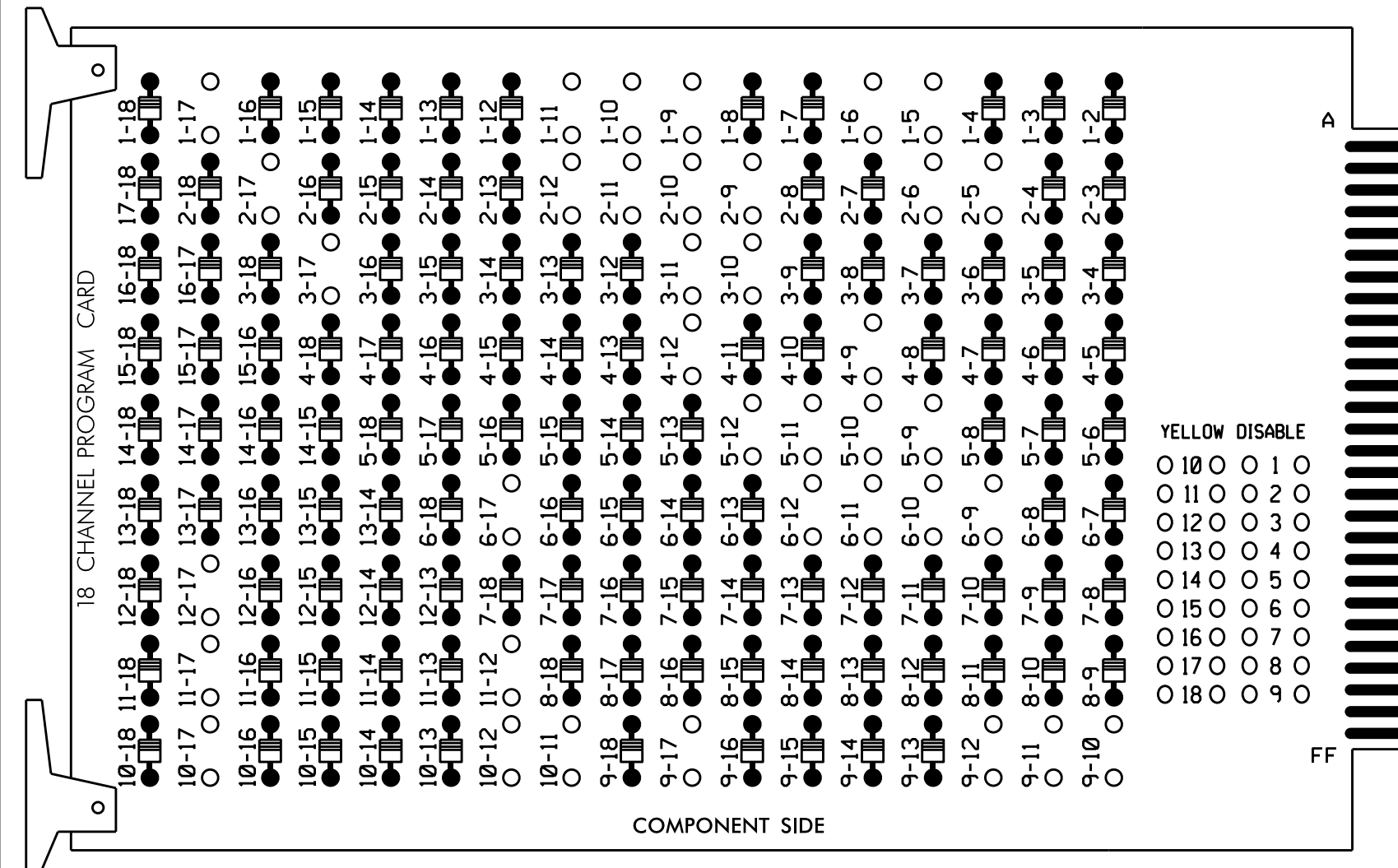

REMOVE JUMPERS AS SHOWN

NOTES:

- Card is provided with all diode jumpers in place. Removal of any jumper allows its channels to run concurrently.
- Ensure jumpers SEL2-SEL5 and SEL9 are present on the monitor board.
- Ensure that Red Enable is active at all times during normal operation.
- Integrate monitor with Ethernet network in cabinet.

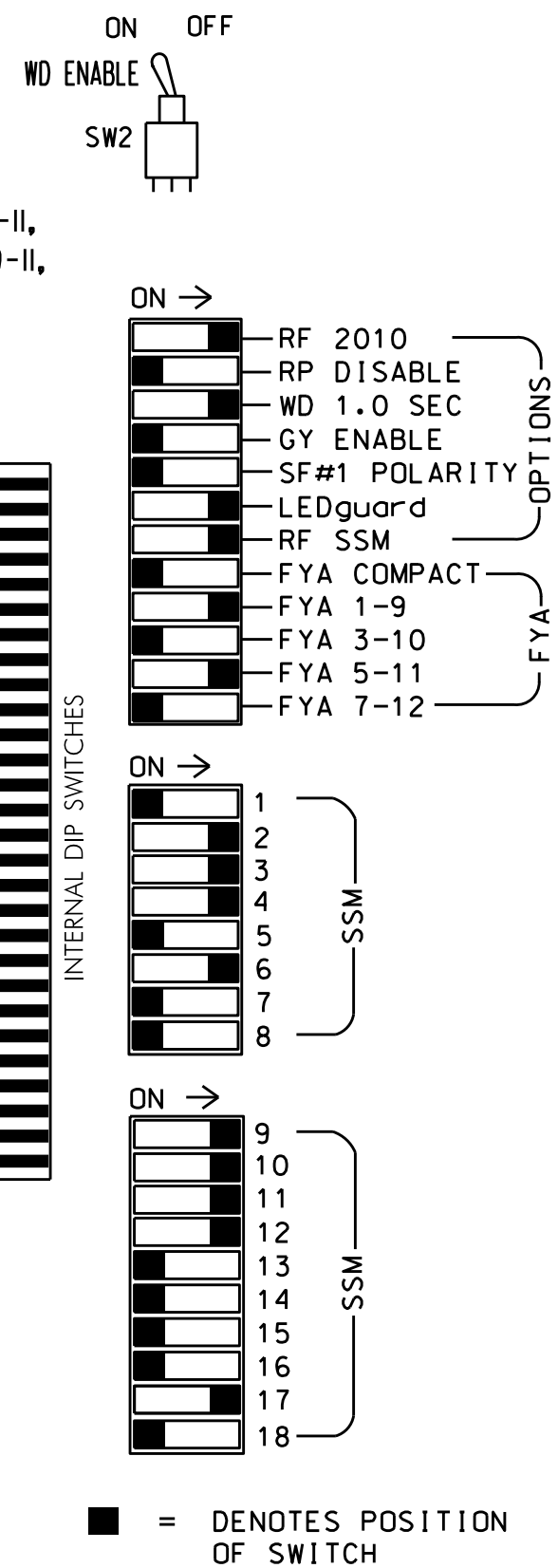

■ = DENOTES POSITION OF SWITCH

NOTES

- To prevent "flash-conflict" problems, insert red flash program blocks for all unused vehicle load switches in the output file. The installer shall verify that signal heads flash in accordance with the Signal Plans.
- Enable Simultaneous Gap-Out for all phases.
- Program phases 2 and 6 for Variable Initial and Gap Reduction.
- Program phases 2 and 6 for Start Up In Green.
- Program phases 2 and 6 for Yellow Flash, and overlaps 1, 2, and 5 as Wag Overlaps.
- The cabinet and controller are part of the Asheville Signal System.

EQUIPMENT INFORMATION

CONTROLLER.....2070E
 CABINET.....332 W/ AUX
 SOFTWARE.....ECONOLITE OASIS
 CABINET MOUNT.....BASE
 OUTPUT FILE POSITIONS...18 WITH AUX. OUTPUT FILE
 LOAD SWITCHES USED.....S1,S2,S4,S5,S7,S8,AUX S1,
 AUX S2,AUX S3,AUX S4,AUX S5
 PHASES USED.....1,2,3,4,5,6
 OVERLAP "A".....1+2+4
 OVERLAP "B".....1+2+3
 OVERLAP "C".....3+5+6
 OVERLAP "D".....2+4
 OVERLAP "E".....3+6

SIGNAL HEAD HOOK-UP CHART

LOAD SWITCH NO.	S1	S2	S3	S4	S5	S6	S7	S8	S9	S10	S11	S12	AUX S1	AUX S2	AUX S3	AUX S4	AUX S5	AUX S6
CMU CHANNEL NO.	1	2	13	3	4	14	5	6	15	7	8	16	9	10	17	11	12	18
PHASE	1	2	2 PED	3	4	4 PED	5	6	6 PED	7	8	8 PED	OLA	OLB	OLE	OLC	OLD	SPARE
SIGNAL HEAD NO.	11	21,22	NU	31,32	41,42	NU	51	61,62	NU	NU	NU	NU	11	63	64,65	51	23,24	NU
RED		128		116	101			134							A111		A101	
YELLOW	*	129		117	102		*	135							A112		A102	
GREEN		130		118	103			136							A113		A103	
RED ARROW													A121	A124			A114	
YELLOW ARROW													A122	A125			A115	
FLASHING YELLOW ARROW													A123	A126			A116	
GREEN ARROW	127						133											

NU = Not Used

* Denotes install load resistor. See load resistor installation detail this sheet.

★ See pictorial of head wiring in detail below.

INPUT FILE POSITION LAYOUT

(front view)

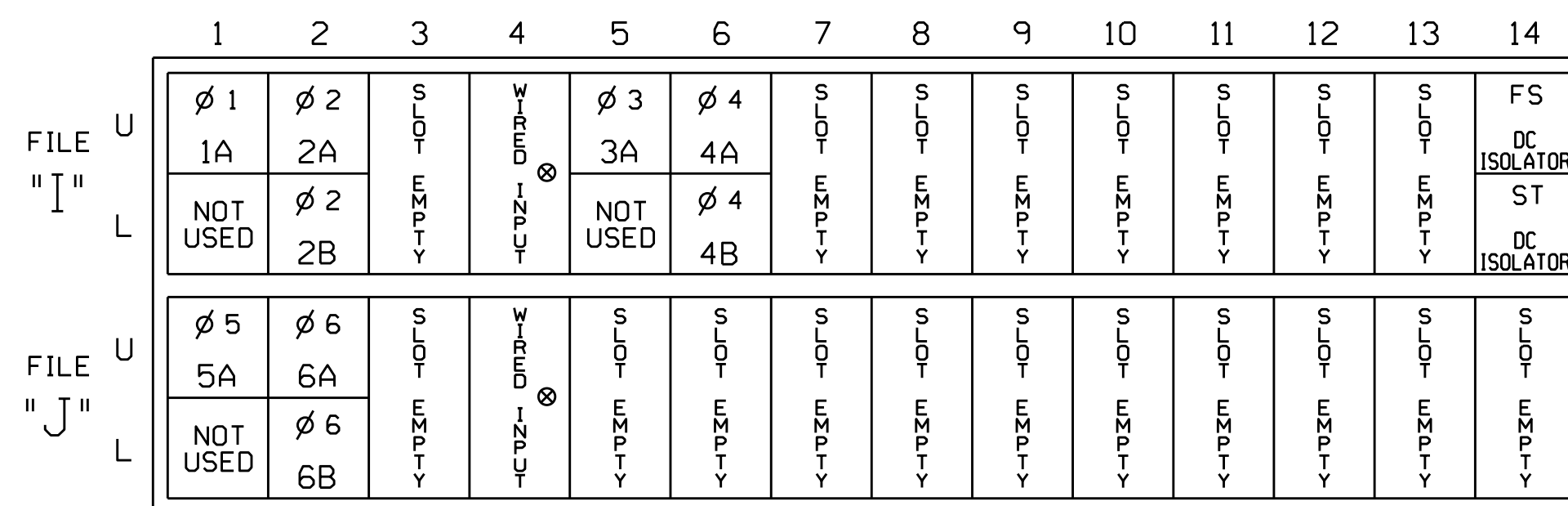

EX.: 1A, 2A, ETC. = LOOP NO.'S

FS = FLASH SENSE
 ST = STOP TIME

⊗ Wired Input - Do not populate slot with detector card

INPUT FILE CONNECTION & PROGRAMMING CHART

LOOP NO.	LOOP TERMINAL	INPUT FILE POS.	PIN NO.	INPUT ASSIGNMENT NO.	DETECTOR NO.	NEMA PHASE	CALL	EXTEND	FULL TIME DELAY	STRETCH TIME	DELAY TIME
1A ¹	TB2-1,2	I1U	56	18	1	1	Y	Y			15
	-	J4U	48	10	26	6	Y	Y	Y		3
2A	TB2-5,6	I2U	39	1	2	2	Y	Y			
2B	TB2-7,8	I2L	43	5	12	2	Y	Y			
3A	TB4-5,6	I5U	58	20	3	3	Y	Y			10
4A	TB4-9,10	I6U	41	3	4	4	Y	Y			3
4B	TB4-11,12	I6L	45	7	14	4	Y	Y			15
5A ²	TB3-1,2	J1U	55	17	5	5	Y	Y			15
	-	I4U	47	9	22	2	Y	Y	Y		3
6A	TB3-5,6	J2U	40	2	6	6	Y	Y			
6B	TB3-7,8	J2L	44	6	16	6	Y	Y			

¹Add jumper from I1-W to J4-W, on rear of input file.

²Add jumper from J1-W to I4-W, on rear of input file.

INPUT FILE POSITION LEGEND: J2L

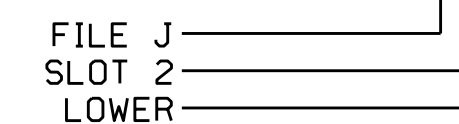

FYA SIGNAL WIRING DETAIL

(wire signal heads as shown)

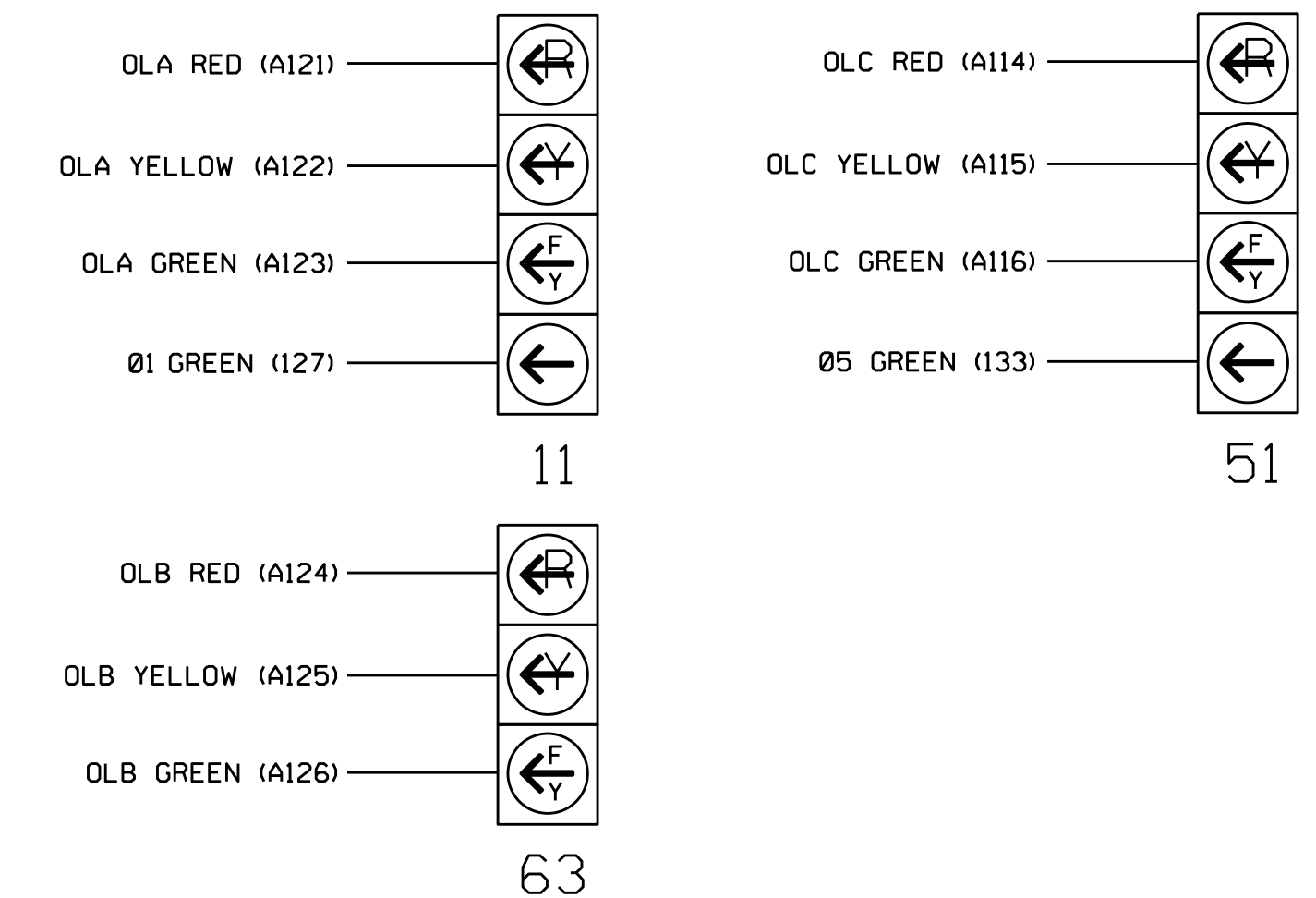

NOTE

The sequence display for signal heads 11 and 51 requires special logic programming. See sheet 2 for programming instructions.

LOAD RESISTOR INSTALLATION DETAIL

(install resistors as shown below)

VALUE (ohms)	WATTAGE
1.5K - 1.9K	25W (min)
2.0K - 3.0K	10W (min)

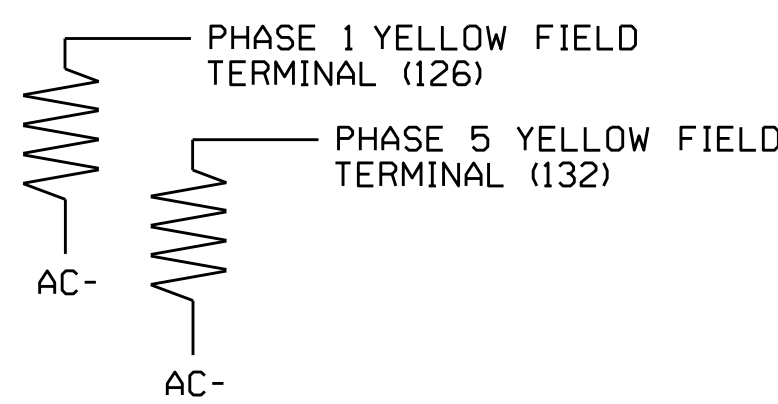

Electrical Detail - Sheet 1 of 3

DOCUMENT NOT CONSIDERED FINAL UNLESS ALL SIGNATURES COMPLETED

Prepared In the Offices of:
 Transportation Mobility and Safety
 750 N. Greenfield Pkwy, Garner, NC 27529

US 70 (Tunnel Road) at Pleasant Ridge Drive and SR 2001 (Arnold Road)

Division 13 Buncombe County Asheville

PLAN DATE: October 2016 REVIEWED BY: BAS
 PREPARED BY: S. Armstrong REVIEWED BY:

REVISIONS INIT. DATE

DocuSigned by:
 Keith M. Mims 11/3/2016

SEAL
 NORTH CAROLINA PROFESSIONAL ENGINEER
 KEITH M. MIMS
 036880

SIG. INVENTORY NO. 13-0707