

RAILROAD PREEMPTION PROGRAMMING DETAIL

(program controller as shown below)

From Main Menu press 'A' (Preemption), then '1' (Standard Preemptions).

PREEMPTION #1	SETTINGS (NEXT:1-10)								
INTERVAL/TIMING	GRN	YEL	RED	CLEAR/DWELL PHASES					
1	32	3.8	1.7	X	X				
2	255	0.0	0.0	X	X				
3	0	0.0	0.0						
4	0	0.0	0.0						
5	1	0.0	0.0	X	X				

EXIT CALLS	OPTIONS								
PRIORITY (Y/N TO SELECT)HIGH								
DELAY TIMER (0-255 SEC)0								
MIN GREEN BEFORE PRE (0= DEFAULT)1								
PED CLEAR BEFORE PRE (0= DEFAULT)5								
YELLOW CLEAR BEFORE PRE (0= DEFAULT)3.8								
RED CLEAR BEFORE PRE (0= DEFAULT)2.3								
DWELL MIN TIMER (0-255 SEC)7								
DWELL MAX TIMER (0=OFF,1-255MIN)0								
DWELL HOLD-OVER TIMER (0-255)0								
LATCH CALL?N								
LINK TO NEXT PREEMPT?N								
ENABLE BACKUP PROTECTION?Y								
HOLD CLEAR 1 PHASES DURING DELAY?N								
FAST GREEN FLASH DWELL PHASES?N								
PED CLEARANCE THROUGH YELLOW?Y								
INHIBIT OVERLAP GREEN EXTENSION?N								
SERVICE DURING SOFTWARE FLASH?N								
REST IN RED DURING DWELL INTERVAL?N								
FLASH DWELL INTERVAL?N								
ALLOW PEDS IN DWELL INTERVAL?Y								
RE-TIME DWELL INTERVAL?N								
OVERLAPS:ABCDEFGHIJKLMN								
DWELL INT FLASH YELLOWX X								
OMIT OVERLAPS:X X X								

**PREEMPT 1 AC ISOLATOR (MODEL 252)
OUTPUT PROGRAMMING DETAIL**

(set DIP switches as shown below)

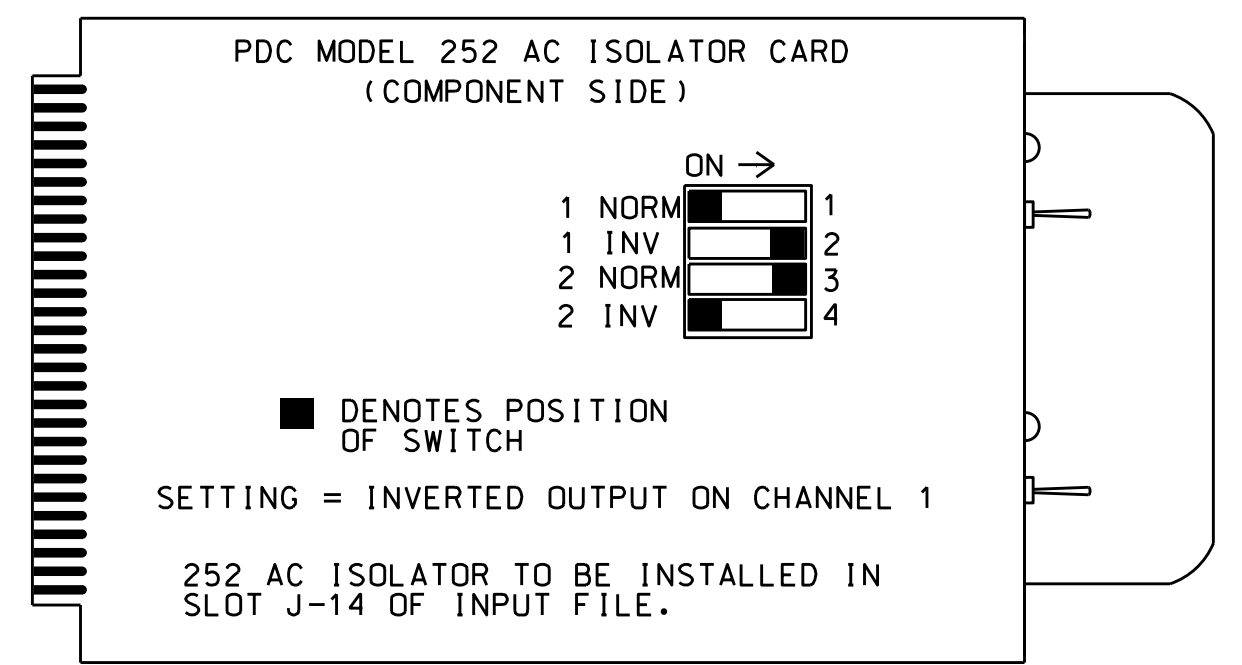

NOTE: IF ANOTHER MANUFACTURER TYPE OF AC ISOLATOR IS USED, OUTPUT PROGRAMMING IS LIKELY NOT TO EQUATE TO THAT SHOWN ABOVE.

RAILROAD PREEMPTION WIRING DETAIL

(wire as shown below)

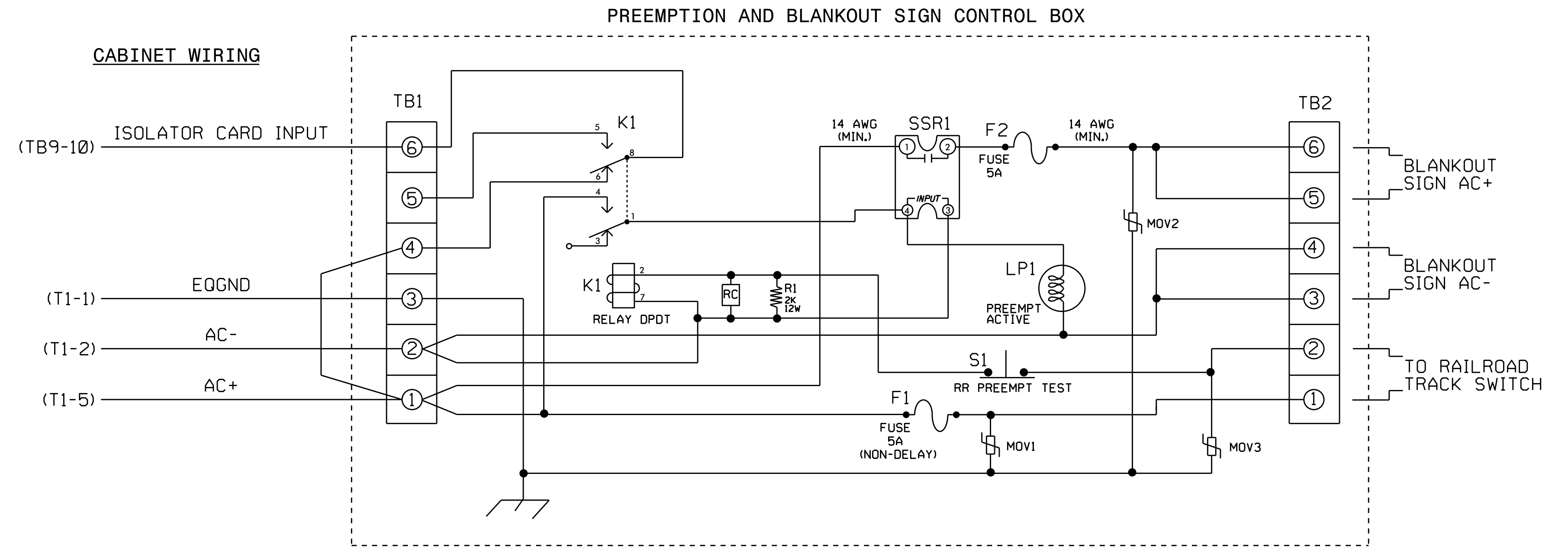

NOTES

- Relay K1 is shown in the energized (Preempt not active) normal operation state.
- Relay K1 is a DPDT with 120VAC coil with octal base.
- Relay SSR1 is a SPST (normally open) Solid State Relay with AC input and AC (25 amp) output.
- AC Isolator Card shall activate preemption upon removal of AC+ from the input (as shown above). To accomplish this set invert dip switch on AC Isolator Card.
- IMPORTANT!! A jumper must be added between input file terminals J14-E and J14-K if not already present. Also, terminal TB9-12 (on input panel) shall be connected to AC neutral (jumper may have to be added).

FRONT VIEW

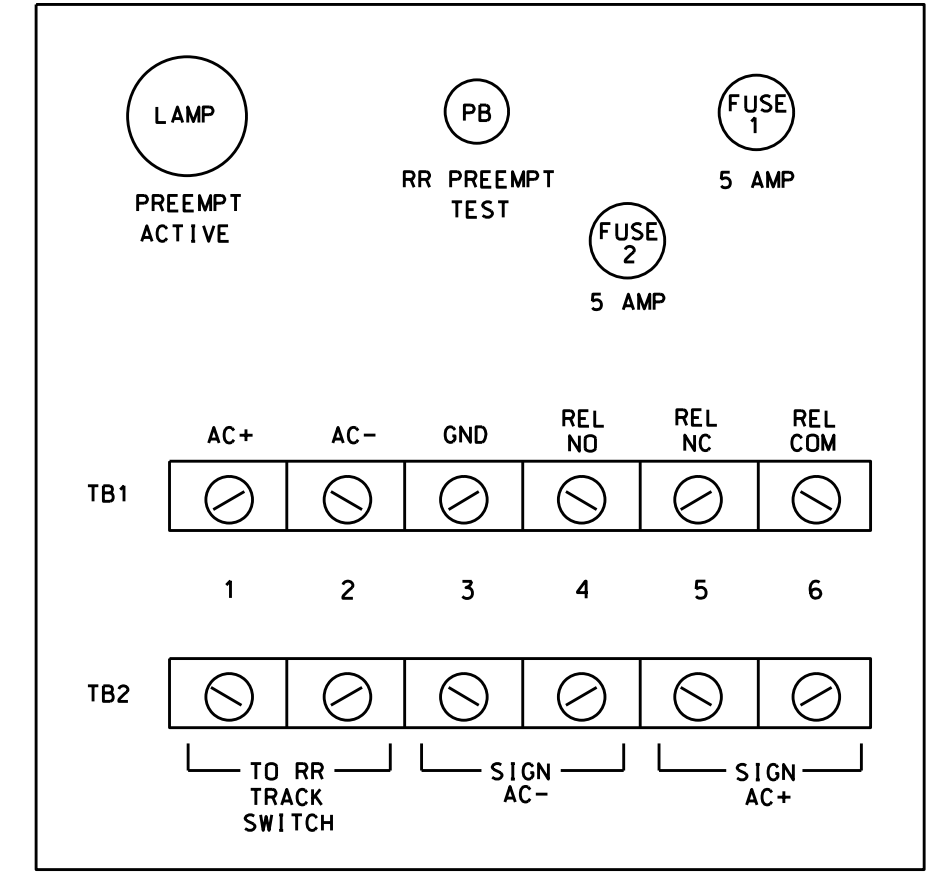

Electrical Detail - Sheet 3 of 3

DOCUMENT NOT CONSIDERED FINAL UNLESS ALL SIGNATURES COMPLETED

THIS ELECTRICAL DETAIL IS FOR THE SIGNAL DESIGN: 13-0242
DESIGNED: January 2016
SEALED: 11/7/2016
REVISED:

	NC 81 (Hendersonville Rd.) at US 25A (Lodge St.)		
	Division 13 PLAN DATE: August 2016 PREPARED BY: C. Strickland	Buncombe County ASHEVILLE REVIEWED BY: T. Joyce REVIEWED BY:	

07-1009-2016-14509
C:\WITS\GIS\TIS_Signal\work\hgr\output\sig_Man\Strickland\130242_sml_e_xxv.dgn
C:\WITS\GIS\TIS_Signal\work\hgr\output\sig_Man\Strickland